

2014-11-13 Change Power IC into EMH7601 (Completed)  
C9/C14 use Tantalum Capacitor

2014-12-15 modify:

1. Change R7/R9 value, Output is 2.65V
2. Change the net name as VCC

FCC ID: R6Y-VM4SW

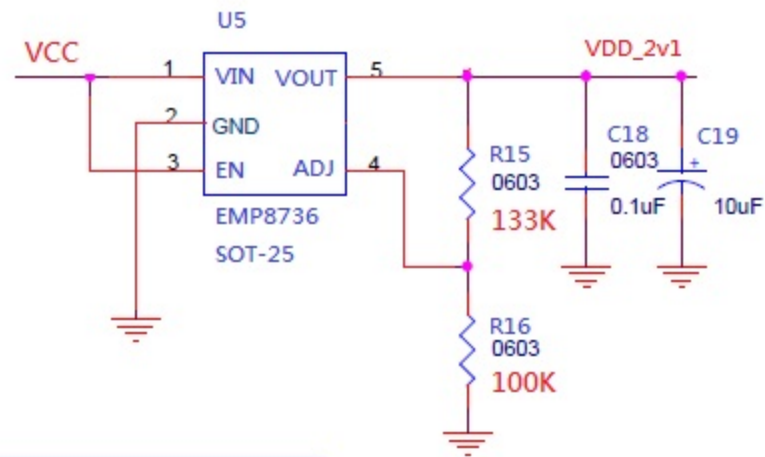

2014-12-15 add:

1. EMP8736 (SOT-25)
2. Input net VCC
3. Output net VDD\_2v1

