

FCC AND IC CERTIFICATION TEST REPORT FOR

Applicant	:	Turning Technologies, LLC
Address	:	255 W. Federal Street Youngstown, OH 44503
Equipment under Test	:	Turning
Model No	:	RRAP-01
Trade Mark	:	/
FCC ID	:	R4WRRAP01
IC	:	5994A-RRAP01
Manufacturer	:	Globalscale Technologies Inc
Address	:	5F.No.2 Building, Minxing Industrial Park, Minkang Road, Minzhi Street, Baoan District, Shenzhen, Guangdong, China

Issued By: Dongguan Dongdian Testing Service Co., Ltd.

Add: No. 17, Zongbu Road 2, Songshan Lake Sci&Tech, Industry Park, Dongguan City,
Guangdong Province, China, 523808

Tel: +86-0769-22891499 [Http://www.dgddt.com](http://www.dgddt.com)

REPORT

TABLE OF CONTENTS

	Test report declares.....	4
1.	Summary of test results	5
2.	General test information.....	6
2.1.	Description of EUT	6
2.2.	Accessories of EUT.....	6
2.3.	Assistant equipment used for test.....	6
2.4.	Block diagram of EUT configuration for test	6
2.5.	Test environment conditions	7
2.6.	Test laboratory.....	7
2.7.	Measurement uncertainty	7
3.	6dB Bandwidth and 99% Bandwidth.....	9
3.1.	Test equipment	9
3.2.	Block diagram of test setup.....	9
3.3.	Limits	9
3.4.	Test Procedure.....	9
3.5.	6dB Bandwidth Test Result.....	9
3.6.	99% Bandwidth Test Result.....	10
4.	Maximum Peak Output Power	12
4.1.	Test equipment	12
4.2.	Block diagram of test setup.....	12
4.3.	Limits	12
4.4.	Test Procedure.....	12
4.5.	Test Result.....	12
5.	Power Spectral Density	14
5.1.	Test equipment	14
5.2.	Block diagram of test setup.....	14
5.3.	Limits	14
5.4.	Test Procedure.....	14
5.5.	Test Result.....	14
6.	Emissions outside the specified frequency bands	16
6.1.	Test equipment	16
6.2.	Block diagram of test setup.....	16
6.3.	Limits	16
6.4.	Test Procedure.....	16
6.5.	Test Result.....	17
6.6.	Original test data	19

7.	Emissions in restricted frequency bands	108
7.1.	Test equipment	108
7.2.	Block diagram of test setup	108
7.3.	Limit	110
7.4.	Test Procedure.....	111
7.5.	Test result	112
8.	Band Edge Compliance	187
8.1.	Test equipment	187
8.2.	Block diagram of test setup	187
8.3.	Limit	187
8.4.	Test Procedure.....	188
8.5.	Test result	188
9.	Power Line Conducted Emission	205
9.1.	Test equipment	205
9.2.	Block diagram of test setup	205
9.3.	Power Line Conducted Emission Limits(Class B).....	205
9.4.	Test Procedure.....	205
9.5.	Test Result.....	206
10.	Antenna Requirements	209
10.1.	Limit	209
10.2.	Result.....	209
11.	Test setup photograph	210
12.	Photos of the EUT	212

TEST REPORT DECLARE

Applicant	:	Turning Technologies, LLC
Address	:	255 W. Federal Street Youngstown, OH 44503
Equipment under Test	:	Turning
Model No	:	RRAP-01
FCC ID	:	R4WRRAP01
IC	:	5994A-RRAP01
Trade Mark	:	/
Manufacturer	:	Globalscale Technologies Inc
Address	:	5F.No.2 Building, Minxing Industrial Park, Minkang Road, Minzhi Street, Baoan District, Shenzhen, Guangdong, China

Test Standard Used: FCC Rules and Regulations Part 15 Subpart C: 2012; RSS-210 Issue 8, December 2010; RSS-Gen Issue 4, December 2010

Test procedure used: ANSI C63.10:2013; KDB558074 D01 DTS Meas Guidance V03r02, KDB 662911 D01 Multiple Transmitter Output v02r01

We Declare:

The equipment described above is tested by Dongguan Dongdian Testing Service Co., Ltd and in the configuration tested the equipment complied with the standards specified above. The test results are contained in this test report and Dongguan Dongdian Testing Service Co., Ltd is assumed of full responsibility for the accuracy and completeness of these tests.

After test and evaluation, our opinion is that the equipment provided for test compliance with the requirement of the above FCC and IC Sandards.

Report No:	DDT-REF140345		
Date of Test:	Aug.25,2014---Sep.30,2014	Date of Report:	Mar.16,2014

Prepared By:



Leo Liu/Engineer



Jamy Yu/EMC Manager

Note: This report applies to above tested sample only. This report shall not be reproduced in parts without written approval of Dongguan Dongdian Testing Service Co., Ltd.

1. Summary of test results

The EUT have been tested according to the applicable standards as referenced below.		
Description of Test Item	Standard	Results
6dB Bandwidth and 99% bandwidth	FCC Part 15: 15.247 KDB558074 RSS-210 Issue 8	PASS
Peak Output Power	FCC Part 15: 15.247 KDB558074 RSS-210 Issue 8	PASS
Power Spectral Density	FCC Part 15: 15.247 KDB558074 RSS-210 Issue 8	PASS
Emissions outside the specified frequency bands	FCC Part 15: 15.247 KDB558074 RSS-210 Issue 8	PASS
Emissions in restricted frequency bands	FCC Part 15: 15.209 FCC Part 15: 15.247 ANSI C63.10: 2013 KDB558074 RSS-210 Issue 8	PASS
Band Edge Compliance	FCC Part 15: 15.209 FCC Part 15: 15.247 ANSI C63.10: 2013 KDB558074 RSS-210 Issue 8	PASS
Power Line Conducted Emission	FCC Part 15: 15.207 ANSI C63.10: 2013 RSS-Gen Issue3	PASS
Antenna requirement	FCC Part 15: 15.203 RSS-210 Issue 8	PASS

2. General test information

2.1. Description of EUT

EUT* Name	: Turning
Model Number	: RRAP-01
EUT function description	: Please reference user manual of this device
Power supply	: DC 12V from adapter input AC100-240V
Radio Technology	: IEEE802.11b/g/n
FCC Operation frequency	: IEEE 802.11b: 2412MHz—2462MHz IEEE 802.11g: 2412MHz—2462MHz IEEE 802.11n HT20: 2412MHz—2462MHz IEEE 802.11n HT40: 2422MHz—2452MHz
Modulation	: IEEE 802.11b: DSSS(CCK,DQPSK,DBPSK) IEEE 802.11g: OFDM(64QAM, 16QAM, QPSK, BPSK) IEEE 802.11n HT20, HT40: OFDM (64QAM, 16QAM, QPSK,BPSK)
Antenna Type	: Integrated Patch Antenna, 2.7dBi maximum gain MIMO 4X4
Date of Receipt	: 2014/07/24
Sample Type	: Series production

Note1: EUT is the ab.of equipment under test.

2.2. Accessories of EUT

Description of Accessories	Manufacturer	Model number or Type	Serial No.	Other
Switching adapter	Shenzhen Fujia Appliance Co.,Ltd	FJ-SW1202000N	/	1.5m
Switching adapter	I.T.E	GEO241U-1220	/	1.5m

2.3. Assistant equipment used for test

Description of Assistant equipment	Manufacturer	Model number or Type	Other
Control PC	Dell	D610	/
Router	TP-link	TL-WR742N	/

2.4. Block diagram of EUT configuration for test

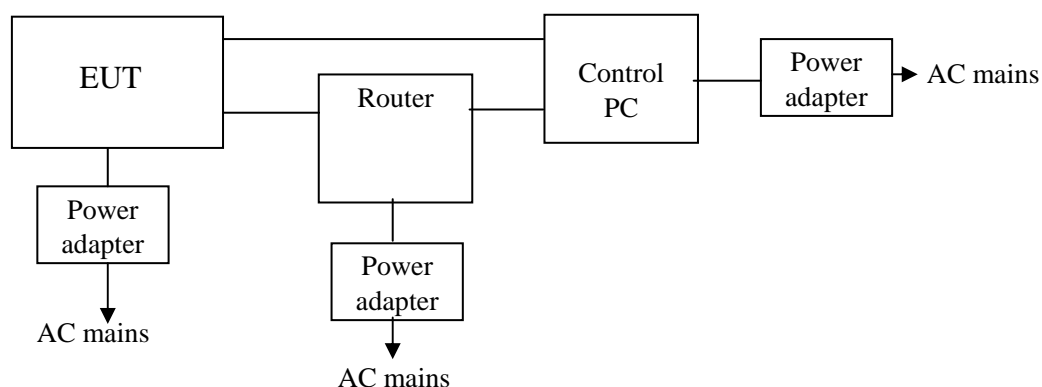

EUT was connected to control PC by LAN cable through router and USB cable, control PC run “putty_xp.exe” and “Dutapimimoudp87xx.exe” test software and special command provided by manufacturer to control EUT work in Continuous TX mode (>98% duty cycle), and select test channel, wireless mode and data rate.

Tested mode, channel, and data rate information			
Mode	data rate (Mbps) (see Note)	Channel	Frequency (MHz)
IEEE 802.11b	11	Low :CH1	2412
	11	Middle: CH6	2437
	11	High: CH11	2462
IEEE 802.11g	6	Low :CH1	2412
	6	Middle: CH6	2437
	6	High: CH11	2462
IEEE 802.11n HT20	MCS 0	Low :CH1	2412
	MCS 0	Middle: CH6	2437
	MCS 0	High: CH11	2462
IEEE 802.11n HT40	MCS 0	Low :CH3	2422
	MCS 0	Middle: CH6	2437
	MCS 0	High: CH9	2452

Note: According exploratory test, EUT will have maximum output power in those data rate, so those data rate were used for all test.

2.5. Test environment conditions

During the measurement the environmental conditions were within the listed ranges:

Temperature range:	21-25°C
Humidity range:	40-75%
Pressure range:	86-106kPa

2.6. Test laboratory

Dongguan Dongdian Testing Service Co., Ltd

Add: No. 17, Zongbu Road 2, Songshan Lake Sci&Tech, Industry Park, Dongguan City, Guangdong

Province, China, 523808 Tel: +86-0769-22891499 <http://www.dgddt.com>

FCC Registration Number: 270092 Industry Canada site registration number: 10288A-1

2.7. Measurement uncertainty

Test Item	Uncertainty
Occupied Channel Bandwidth	±1%
Uncertainty for radio frequency	1×10^{-9}
RF Output power, conducted	±0.6dB

Power Spectral Density, Conducted	±1.2dB
Unwanted Emissions, Conducted	±0.6dB
Temperature	±0.2°C
Humidity	±1%
DC and Low frequency voltage	±0.5%
Time	±1%
Duty Cycle	±1%
Uncertainty for Radiation Emission test (30MHz-1GHz)	3.14 dB (Polarize: V)
	3.16 dB (Polarize: H)
Uncertainty for Radiation Emission test (1GHz to 25GHz)	2.08dB(Polarize: V)
	2.56dB (Polarize: H)
Uncertainty for Conduction emission test(150KHz-30MHz)	2.44dB
Uncertainty for Radiation Emission test (9KHz-150KHz)	3.89dB
Uncertainty for Radiation Emission test (150KHz-30MHz)	3.21dB

Note: This uncertainty represents an expanded uncertainty expressed at approximately the 95% confidence level using a coverage factor of k=2.

3. 6dB Bandwidth and 99% Bandwidth

3.1. Test equipment

Item	Equipment	Manufacturer	Model No.	Serial No.	Last Cal.	Cal. Interval
1	Spectrum analyzer	R&S	FSU	1166.1660.26	2013/11/13	1 Year
2	Attenuator	Mini-Circuits	BW-S10W2	101109	2013/11/13	1 Year
3	RF Cable	Micable	C10-01-01-1	100309	2013/11/13	1 Year

3.2. Block diagram of test setup

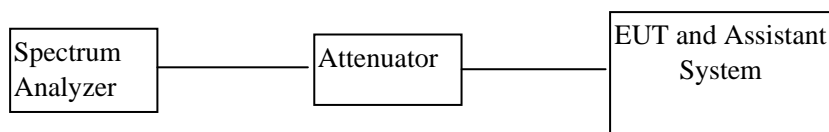

3.3. Limits

For direct sequence systems, the minimum 6dB bandwidth shall be at least 500 KHz

3.4. Test Procedure

- (1) Configure EUT and assistant system according clause 2.4 and 3.2
- (2) Connect each EUT's antenna output to spectrum analyzer by RF cable.
- (3) Configure EUT work in test mode as stated in clause 2.4.
- (4) Set the spectrum analyzer as follows:

RBW:	100KHz
VBW:	300KHz
Detector Mode:	Peak
Sweep time:	auto
Trace mode	Max hold

- (5) Allow the trace to stabilize, measure the maximum width of the emission that is constrained by the frequencies associated with the two outermost amplitude points (upper and lower frequencies) that are attenuated by 6 dB relative to the maximum level measured in the fundamental emission.
- (6) Measure the 99% bandwidth use the bandwidth measure function of Spectrum analyzer.

3.5. 6dB Bandwidth Test Result

Mode	CH or Frequency	6dB bandwidth Result (MHz)	Mode	CH or Frequency	6dB bandwidth Result (MHz)
Chain 1					
11b	CH1	10.096	11n HT 20	CH1	17.869
	CH6	9.615		CH6	18.869

	CH11	10.096		CH11	17.788
11g	CH1	16.587	11n HT 40	CH3	37.821
	CH6	16.587		CH6	37.885
	CH11	16.587		CH9	37.788
Chain 2					
11b	CH1	10.016	11n HT 20	CH1	17.869
	CH6	10.096		CH6	17.869
	CH11	9.696		CH11	17.788
11g	CH1	16.667	11n HT 40	CH3	37.821
	CH6	16.667		CH6	37.885
	CH11	16.667		CH9	37.788
Chain 3					
11b	CH1	10.096	11n HT 20	CH1	17.869
	CH6	10.096		CH6	17.869
	CH11	10.096		CH11	17.869
11g	CH1	16.667	11n HT 40	CH3	37.821
	CH6	16.587		CH6	37.804
	CH11	16.587		CH9	37.788
Chain 4					
11b	CH1	9.615	11n HT 20	CH1	17.869
	CH6	9.935		CH6	17.949
	CH11	10.096		CH11	17.869
11g	CH1	16.667	11n HT 40	CH3	37.821
	CH6	16.667		CH6	37.804
	CH11	16.667		CH9	37.788
Limit: >500KHz			Conclusion: PASS		
Test Date : Aug.25,2014			Test Engineer : Leo Liu		

3.6. 99% Bandwidth Test Result

Mode	CH or Frequency	99% bandwidth Result (MHz)	Mode	CH or Frequency	99% bandwidth Result (MHz)
Chain 1					
11b	CH1	15.012	11n HT 20	CH1	17.789
	CH6	15.034		CH6	17.788
	CH11	15.132		CH11	17.785
11g	CH1	16.668	11n HT 40	CH3	35.891
	CH6	16.667		CH6	36.032
	CH11	16.670		CH9	36.103
Chain 2					
11b	CH1	15.021	11n HT 20	CH1	17.790
	CH6	15.120		CH6	17.786
	CH11	15.114		CH11	17.780
11g	CH1	16.665	11n HT 40	CH3	36.034

	CH6	16.670		CH6	36.123
	CH11	16.653		CH9	36.103
Chain 3					
11b	CH1	15.024	11n HT 20	CH1	17.789
	CH6	15.090		CH6	17.783
	CH11	15.122		CH11	17.783
11g	CH1	16.677	11n HT 40	CH3	36.021
	CH6	16.667		CH6	36.032
	CH11	16.668		CH9	36.021
Chain 4					
11b	CH1	15.121	11n HT 20	CH1	17.765
	CH6	15.110		CH6	17.754
	CH11	15.032		CH11	17.745
11g	CH1	16.665	11n HT 40	CH3	36.010
	CH6	16.667		CH6	36.021
	CH11	16.665		CH9	36.050
Limit: N/A			Conclusion: PASS		
Test Date : Aug.25,2014			Test Engineer : Leo Liu		

4. Maximum Peak Output Power

4.1. Test equipment

Item	Equipment	Manufacturer	Model No.	Serial No.	Last Cal.	Cal. Interval
1	Power meter	Anritsu	ML2495A	1203234	2013/11/13	1 Year
2	Power sensor	Anritsu	MA2411B	1243433	2013/11/13	1 Year
3	Attenuator	Mini-Circuits	BW-S10W2	101109	2013/11/13	1 Year
4	RF Cable	Micable	C10-01-01-1	100309	2013/11/13	1 Year

4.2. Block diagram of test setup

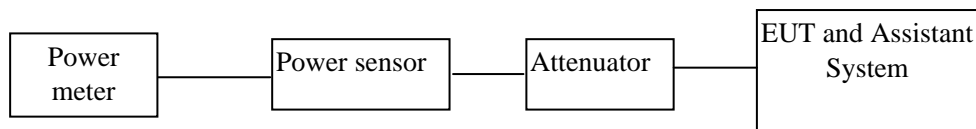

4.3. Limits

For systems using digital modulation in the 902-928 MHz, 2400-2483.5 MHz, and 5725-5850 MHz bands: 1 Watt. If transmitting antennas of directional gain greater than 6 dBi are used, the conducted output power from the intentional radiator shall be reduced below the stated values as appropriate, by the amount in dB that the directional gain of the antenna exceeds 6 dBi.

4.4. Test Procedure

- (1) Configure EUT and assistant system according clause 2.4 and 4.2
- (2) Connect each EUT's antenna output to power sensor by RF cable and attenuator
- (3) Configure EUT work in test mode as stated in clause 2.4.
- (4) Measure out the Average and PK output power of each antenna port
- (5) Add each antenna port's results to get the total output power of EUT.

4.5. Test Result

Mode: 11b						
CH	Type	Channel 1 (dBm)	Channel 2 (dBm)	Channel 3 (dBm)	Channel 4 (dBm)	Result (dBm)
CH1	PK	17.64	17.93	18.18	18.23	24.02
	Average	14.98	15.29	15.55	15.61	21.39
CH6	PK	17.34	17.45	18.12	18.21	23.82
	Average	14.65	15.01	15.34	15.39	21.13
CH11	PK	17.04	17.54	18.01	18.15	23.73

	Average	14.23	14.98	15.24	15.49	21.03
Mode: 11g						
CH	Type	Channel 1 (dBm)	Channel 2 (dBm)	Channel 3 (dBm)	Channel 4 (dBm)	Result (dBm)
CH1	PK	17.45	16.51	16.89	16.52	22.88
	Average	11.31	10.45	10.31	10.25	16.62
CH6	PK	17.24	16.18	16.42	16.11	22.53
	Average	11.35	10.27	10.04	10.05	16.48
CH11	PK	17.23	16.90	16.92	16.95	23.02
	Average	11.50	11.01	10.65	10.44	16.94
Mode 11n HT 20						
CH	Type	Channel 1 (dBm)	Channel 2 (dBm)	Channel 3 (dBm)	Channel 4 (dBm)	Result (dBm)
CH1	PK	19.56	19.65	20.66	20.40	26.11
	Average	12.67	12.71	12.89	12.78	18.78
CH6	PK	19.20	19.21	20.48	19.90	25.75
	Average	12.34	12.43	12.67	12.45	18.49
CH11	PK	19.23	19.45	20.13	20.01	25.74
	Average	12.55	12.13	12.46	12.76	18.50
Mode: 11n HT 40						
CH	Type	Channel 1 (dBm)	Channel 2 (dBm)	Channel 3 (dBm)	Channel 4 (dBm)	Result (dBm)
CH 3	PK	19.54	18.44	18.47	18.56	24.80
	Average	12.13	12.24	11.35	11.45	17.83
CH 6	PK	19.21	18.43	18.41	18.94	24.78
	Average	12.95	12.16	11.83	11.94	18.26
CH 9	PK	19.89	18.95	18.86	18.61	25.13
	Average	12.55	12.32	11.36	11.89	18.07
Limit: 30dBm			Conclusion: PASS			
Test Date :Aug.25,2014			Test Engineer : Leo Liu			

5. Power Spectral Density

5.1. Test equipment

Same with 3.1

5.2. Block diagram of test setup

Same with 3.2

5.3. Limits

For digitally modulated systems, the power spectral density conducted from the intentional radiator to the antenna shall not be greater than 8dBm in any 3 kHz band during any time interval of continuous transmission.

5.4. Test Procedure

- (1) Configure EUT and assistant system according clause 2.4 and 5.2
- (2) Connect EUT's antenna output to spectrum analyzer by RF cable.
- (3) Configure EUT work in test mode as stated in clause 2.4.
- (4) Set the spectrum analyzer as follows:

Center frequency	DTS Channel center frequency
RBW:	$3 \text{ kHz} \leq \text{RBW} \leq 100 \text{ kHz}$
VBW:	$\geq 3\text{RBW}$
Span	1.5times the DTS bandwidth
Detector Mode:	Peak
Sweep time:	auto
Trace mode	Max hold

- (5) Allow the trace to stabilize, use the peak marker function to determine the maximum amplitude level within the RBW.
- (6) If measured value exceeds limit, reduce RBW (no less than 3 kHz) and repeat.

5.5. Test Result

Mode: 11b					
CH	Channel 1 (dBm/30KHz)	Channel 2 (dBm/30KHz)	Channel 3 (dBm/30KHz)	Channel 4 (dBm/30KHz)	Result (dBm/30KHz)
CH1	0.33	0.56	0.43	0.76	6.54
CH6	0.45	0.75	0.36	0.43	6.52
CH11	0.21	1.01	0.39	0.51	6.56
Mode: 11g					

CH	Channel 1 (dBm/30KHz)	Channel 2 (dBm/30KHz)	Channel 3 (dBm/30KHz)	Channel 4 (dBm/30KHz)	Result (dBm/30KHz)
CH1	-2.42	-2.12	-2.56	-2.41	3.65
CH6	-2.71	-2.79	-2.80	-2.77	3.25
CH11	-2.45	-2.65	-2.77	-2.59	3.41
Mode: 11n HT 20					
CH	Channel 1 (dBm/30KHz)	Channel 2 (dBm/30KHz)	Channel 3 (dBm/30KHz)	Channel 4 (dBm/30KHz)	Result (dBm/30KHz)
CH1	-3.13	-3.67	-3.89	-3.23	2.55
CH6	-3.32	-3.97	-4.04	-3.63	2.29
CH11	-3.20	-3.67	-3.56	-3.34	2.58
Mode: 11n HT 40					
CH	Channel 1 (dBm/30KHz)	Channel 2 (dBm/30KHz)	Channel 3 (dBm/30KHz)	Channel 4 (dBm/30KHz)	Result (dBm/30KHz)
CH1	-7.54	-7.12	-7.33	-7.34	-1.31
CH6	-7.95	-7.02	-7.86	-7.43	-1.53
CH11	-7.31	-7.20	-7.43	-7.51	-1.34
Limit: 8dBm/3KHz			Conclusion: PASS		
Test Date : Aug.26, 2014			Test Engineer : Leo Liu		

6. Emissions outside the specified frequency bands

6.1. Test equipment

Same with 3.1

6.2. Block diagram of test setup

Same with 3.2

6.3. Limits

In any 100kHz bandwidth outside the frequency bands in which the spread spectrum intentional radiator is operating, the radio frequency power that is produced by the intentional radiator shall be at least 20dB below that in the 100kHz bandwidth within the band that contains the highest level of the desired power.

6.4. Test Procedure

- (1) Configure EUT and assistant system according clause 2.4 and 6.2
- (2) Connect EUT's antenna output to spectrum analyzer by RF cable.
- (3) Configure EUT work in test mode as stated in clause 2.4.
- (4) Establish a reference level by using the following procedure:

Center frequency	DTS Channel center frequency
RBW:	100KHz
VBW:	300KHz
Span	1.5times the DTS bandwidth
Detector Mode:	Peak
Sweep time:	auto
Trace mode	Max hold

- (5) Allow the trace to stabilize, use the peak marker function to determine the maximum peak power level to establish the reference level.
- (6) Set the spectrum analyzer as follows:

RBW:	100KHz
VBW:	300KHz
Span	Encompass frequency range to be measured
Number of measurement points	$\geq \text{span/RBW}$
Detector Mode:	Peak
Sweep time:	auto
Trace mode	Max hold

- (7) Allow the trace to stabilize, use the peak marker function to determine the maximum amplitude of all

unwanted emissions outside of the authorized frequency band

Note: The conducted emission test is performed on each Tx port of test mode without summing or adding $10\log(N)$ since the limit is relative emission limit.

6.5. Test Result

Channel 1							
Mode	CH	Measured	Result	EUT	CH	Measured Range	Result
11b	CH1	30MHz-1GHz	PASS	11n HT 20	CH1	30MHz-1GHz	PASS
		1GHz-25GHz	PASS			1GHz-25GHz	PASS
		2.3GHz-2.43GHz	PASS			2.3GHz-2.43GHz	PASS
	CH6	30MHz-1GHz	PASS		CH6	30MHz-1GHz	PASS
		1GHz-25GHz	PASS			1GHz-25GHz	PASS
	CH11	30MHz-1GHz	PASS		CH11	30MHz-1GHz	PASS
		1GHz-25GHz	PASS			1GHz-25GHz	PASS
		2.45GHz-2.6GHz	PASS			2.45GHz-2.6GHz	PASS
	11g	CH1	30MHz-1GHz		PASS	11n HT 40	CH3
1GHz-25GHz			PASS	1GHz-25GHz	PASS		
2.3GHz-2.43GHz			PASS	2.3GHz-2.43GHz	PASS		
CH6		30MHz-1GHz	PASS	CH6	30MHz-1GHz		PASS
		1GHz-25GHz	PASS		1GHz-25GHz		PASS
CH11		30MHz-1GHz	PASS	CH9	30MHz-1GHz		PASS
		1GHz-25GHz	PASS		1GHz-25GHz		PASS
		2.45GHz-2.6GHz	PASS		2.43-2.6GHz		PASS

Channel 2							
Mode	CH	Measured	Result	EUT	CH	Measured Range	Result
11b	CH1	30MHz-1GHz	PASS	11n HT 20	CH1	30MHz-1GHz	PASS
		1GHz-25GHz	PASS			1GHz-25GHz	PASS
		2.3GHz-2.43GHz	PASS			2.3GHz-2.43GHz	PASS
	CH6	30MHz-1GHz	PASS		CH6	30MHz-1GHz	PASS
		1GHz-25GHz	PASS			1GHz-25GHz	PASS
	CH11	30MHz-1GHz	PASS		CH11	30MHz-1GHz	PASS
		1GHz-25GHz	PASS			1GHz-25GHz	PASS
		2.45GHz-2.6GHz	PASS			2.45GHz-2.6GHz	PASS
	11g	CH1	30MHz-1GHz		PASS	11n HT 40	CH3
1GHz-25GHz			PASS	1GHz-25GHz	PASS		
2.3GHz-2.43GHz			PASS	2.3GHz-2.43GHz	PASS		
CH6		30MHz-1GHz	PASS	CH6	30MHz-1GHz		PASS
		1GHz-25GHz	PASS		1GHz-25GHz		PASS
CH11		30MHz-1GHz	PASS	CH9	30MHz-1GHz		PASS
		1GHz-25GHz	PASS		1GHz-25GHz		PASS
		1GHz-25GHz	PASS		1GHz-25GHz		PASS

Channel 2							
Mode	CH	Measured	Result	EUT	CH	Measured Range	Result
		2.45GHz-2.6GHz	PASS			2.43-2.6GHz	PASS

Channel 3							
Mode	CH	Measured	Result	EUT	CH	Measured Range	Result
11b	CH1	30MHz-1GHz	PASS	11n HT 20	CH1	30MHz-1GHz	PASS
		1GHz-25GHz	PASS			1GHz-25GHz	PASS
		2.3GHz-2.43GHz	PASS			2.3GHz-2.43GHz	PASS
	CH6	30MHz-1GHz	PASS		CH6	30MHz-1GHz	PASS
		1GHz-25GHz	PASS			1GHz-25GHz	PASS
	CH11	30MHz-1GHz	PASS		CH11	30MHz-1GHz	PASS
		1GHz-25GHz	PASS			1GHz-25GHz	PASS
		2.45GHz-2.6GHz	PASS			2.45GHz-2.6GHz	PASS
	11g	CH1	30MHz-1GHz		PASS	11n HT 40	CH3
1GHz-25GHz			PASS	1GHz-25GHz	PASS		
2.3GHz-2.43GHz			PASS	2.3GHz-2.43GHz	PASS		
CH6		30MHz-1GHz	PASS	CH6	30MHz-1GHz		PASS
		1GHz-25GHz	PASS		1GHz-25GHz		PASS
CH11		30MHz-1GHz	PASS	CH9	30MHz-1GHz		PASS
		1GHz-25GHz	PASS		1GHz-25GHz		PASS
		2.45GHz-2.6GHz	PASS		2.43-2.6GHz		PASS

Channel 4							
Mode	CH	Measured	Result	EUT	CH	Measured Range	Result
11b	CH1	30MHz-1GHz	PASS	11n HT 20	CH1	30MHz-1GHz	PASS
		1GHz-25GHz	PASS			1GHz-25GHz	PASS
		2.3GHz-2.43GHz	PASS			2.3GHz-2.43GHz	PASS
	CH6	30MHz-1GHz	PASS		CH6	30MHz-1GHz	PASS
		1GHz-25GHz	PASS			1GHz-25GHz	PASS
	CH11	30MHz-1GHz	PASS		CH11	30MHz-1GHz	PASS
		1GHz-25GHz	PASS			1GHz-25GHz	PASS
		2.45GHz-2.6GHz	PASS			2.45GHz-2.6GHz	PASS
	11g	CH1	30MHz-1GHz		PASS	11n HT 40	CH3
1GHz-25GHz			PASS	1GHz-25GHz	PASS		
2.3GHz-2.43GHz			PASS	2.3GHz-2.43GHz	PASS		
CH6		30MHz-1GHz	PASS	CH6	30MHz-1GHz		PASS
		1GHz-25GHz	PASS		1GHz-25GHz		PASS
CH11		30MHz-1GHz	PASS	CH9	30MHz-1GHz		PASS
		1GHz-25GHz	PASS		1GHz-25GHz		PASS
		2.45GHz-2.6GHz	PASS		2.43-2.6GHz		PASS

6.6. Original test data

Chain 1 11b CH 1

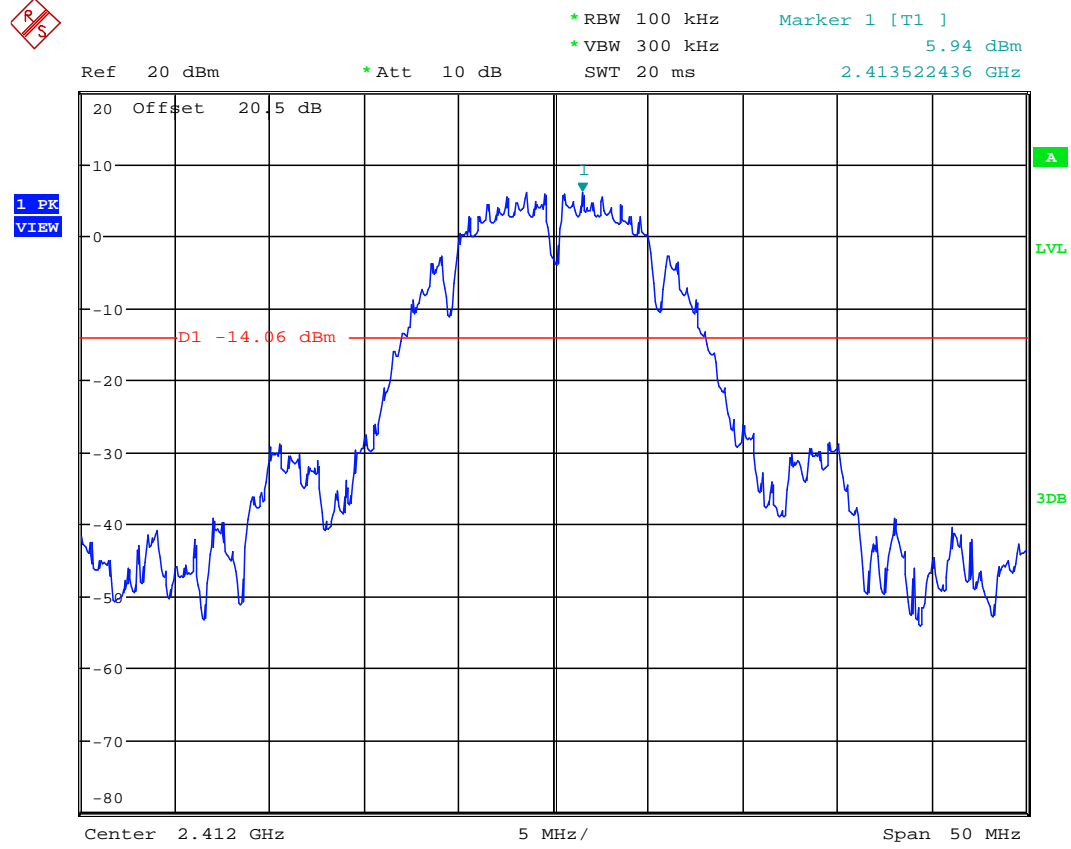

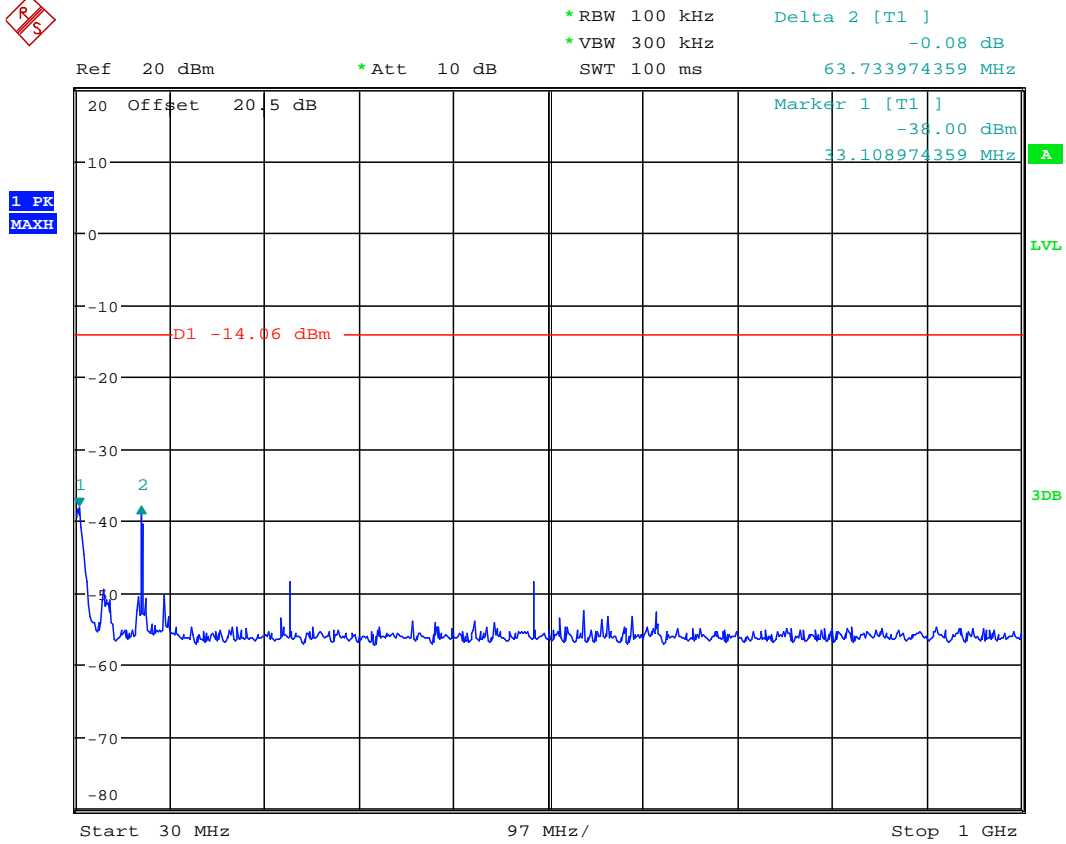
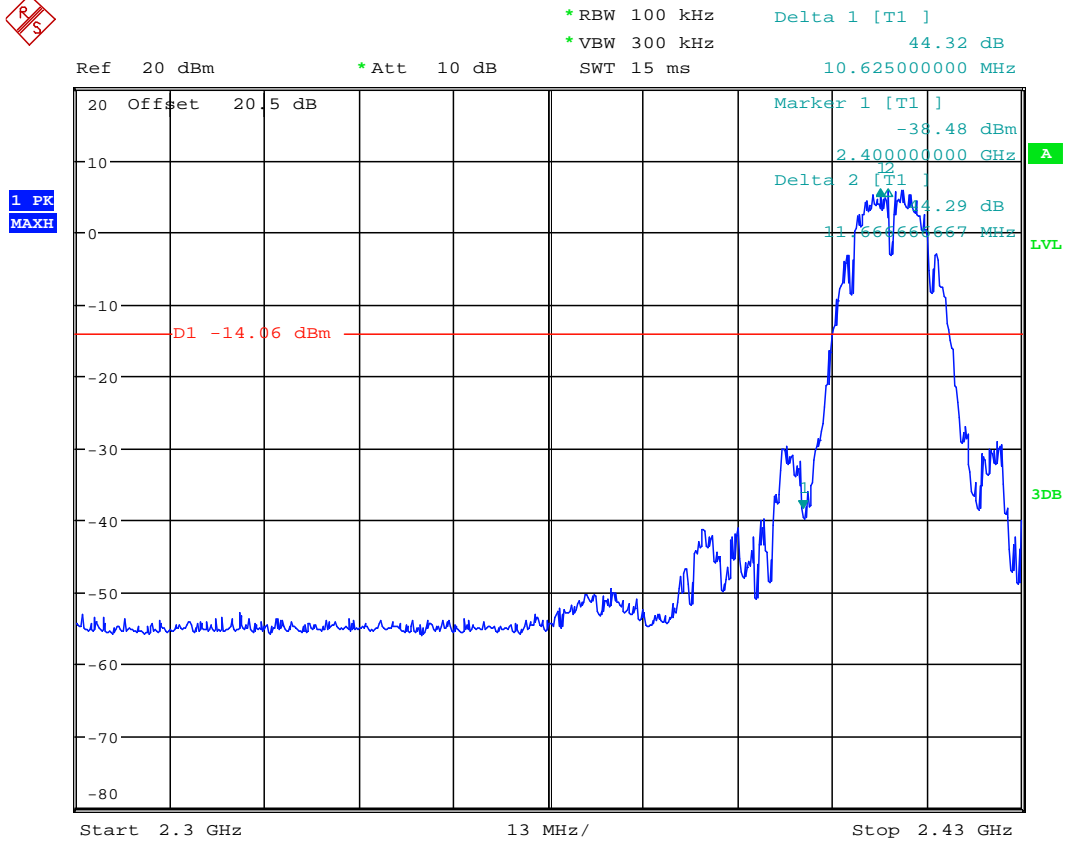

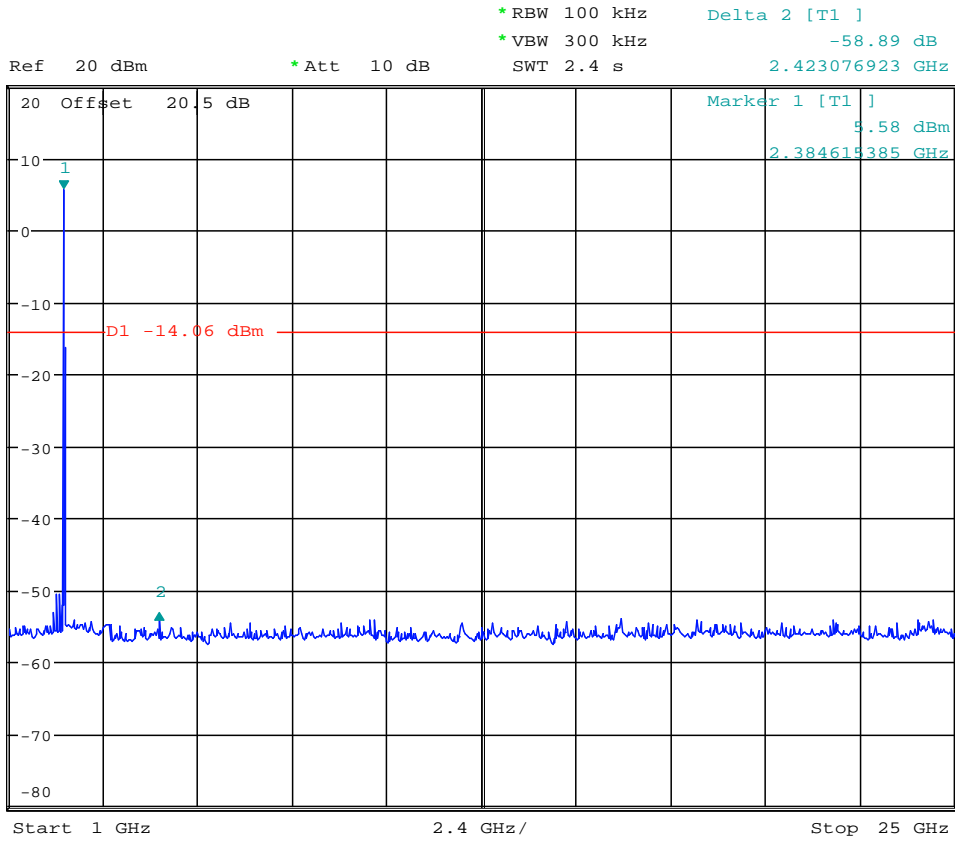

Chain 1 11b CH 6

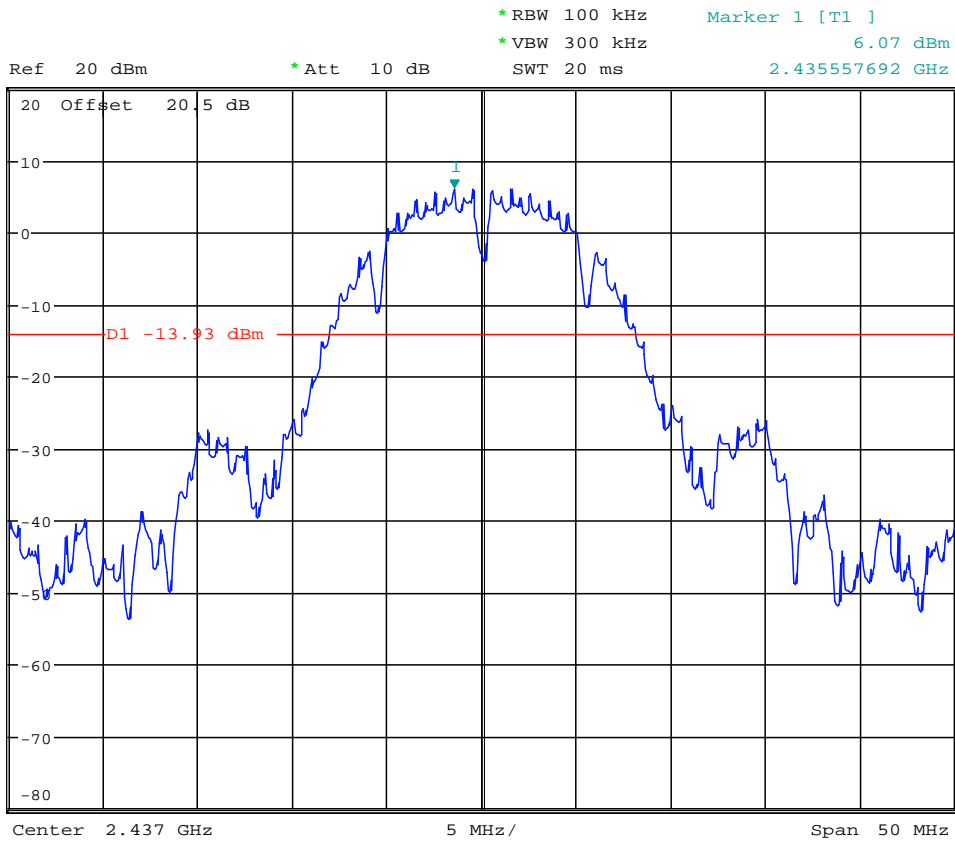



1 PK
MAXH

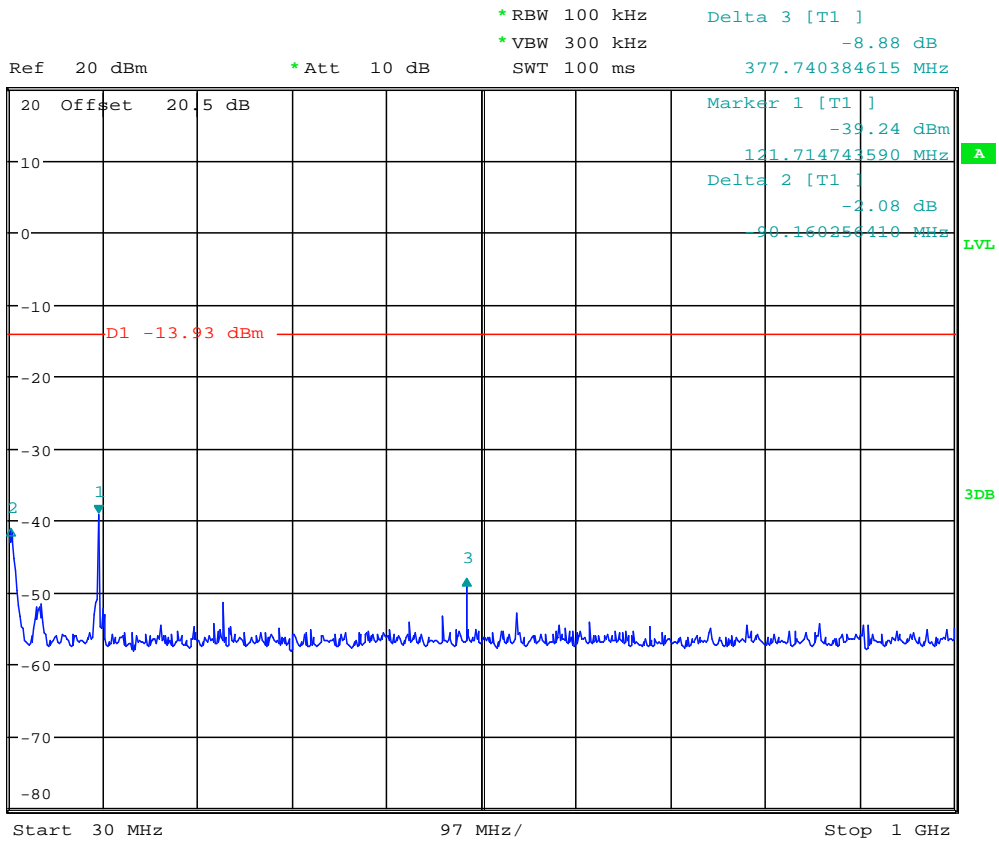

1 PK
MAXH

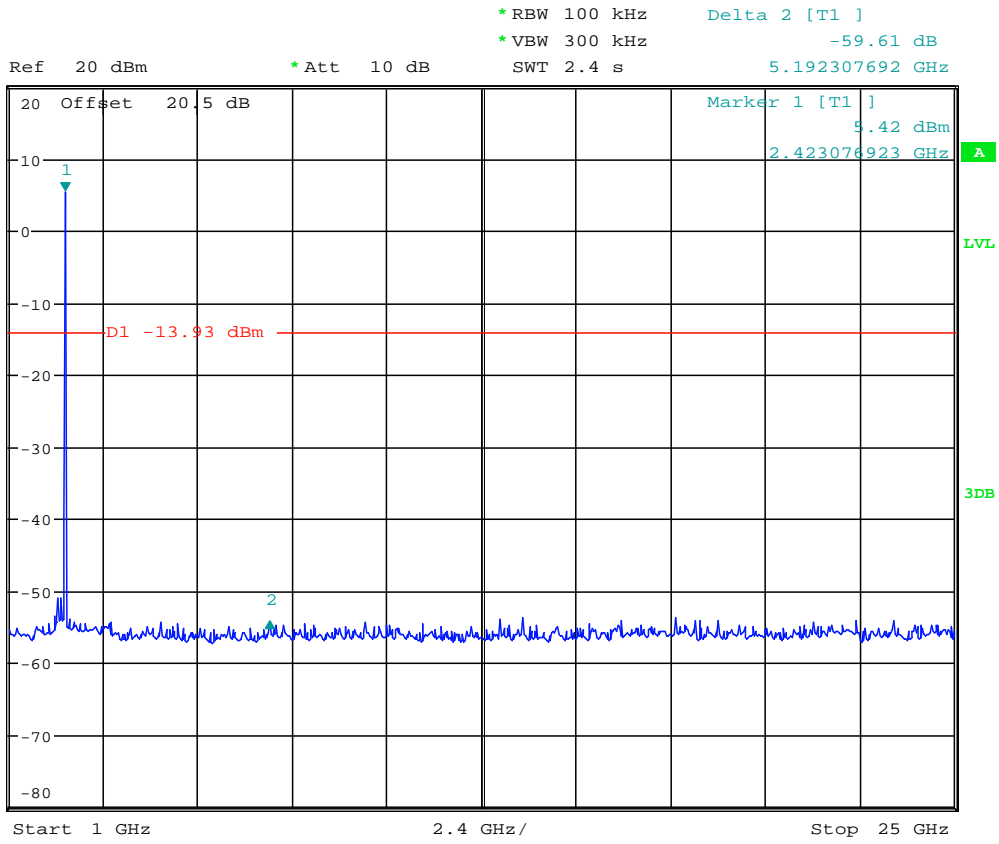

Chain 1 11b CH 11



Ref 20 dBm *Att 10 dB *RBW 100 kHz *VBW 300 kHz SWT 20 ms Marker 1 [T1] 5.70 dBm 2.460557692 GHz

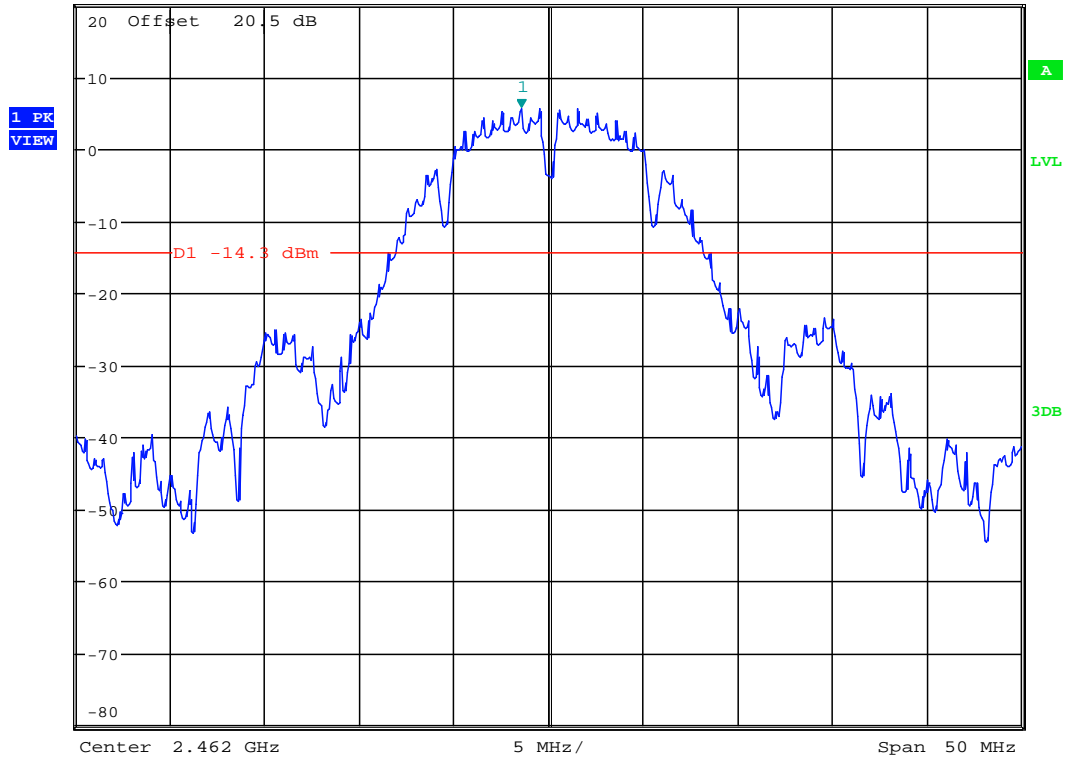

Ref 20 dBm *Att 10 dB *RBW 100 kHz *VBW 300 kHz SWT 15 ms Marker 2 [T1] -40.51 dBm 2.483500000 GHz

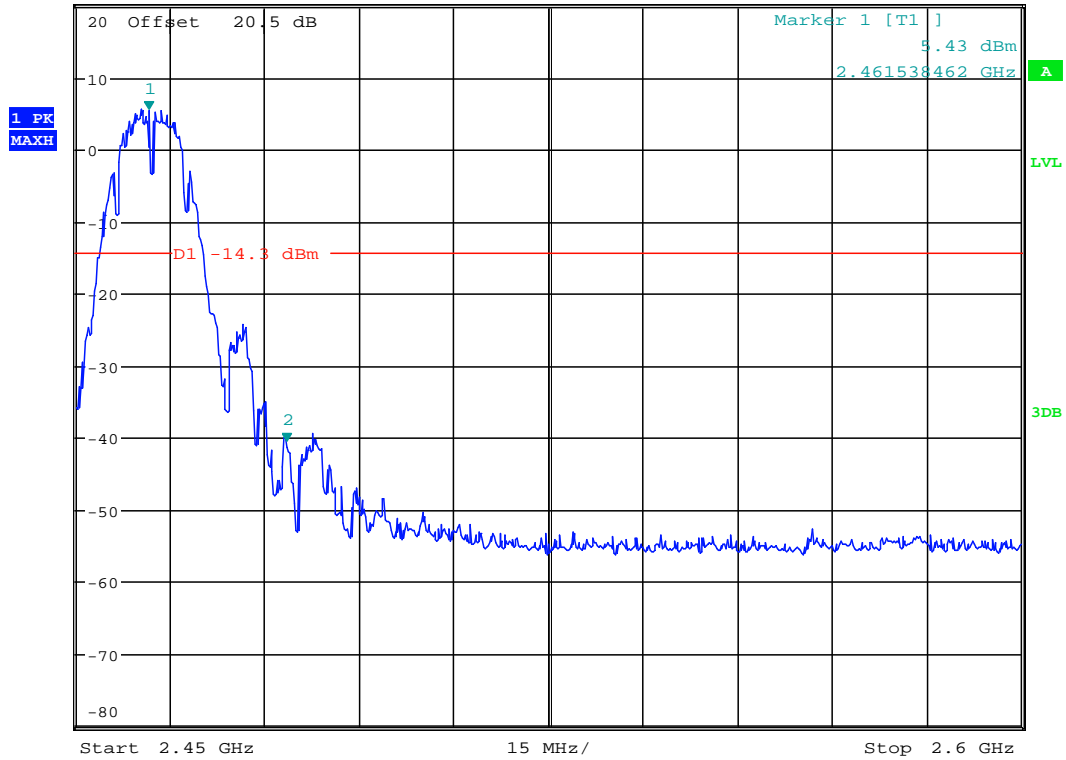



Ref 20 dBm *Att 10 dB *RBW 100 kHz Delta 2 [T1] -0.65 dB
 *VBW 300 kHz -113.477564103 MHz
 SWT 100 ms

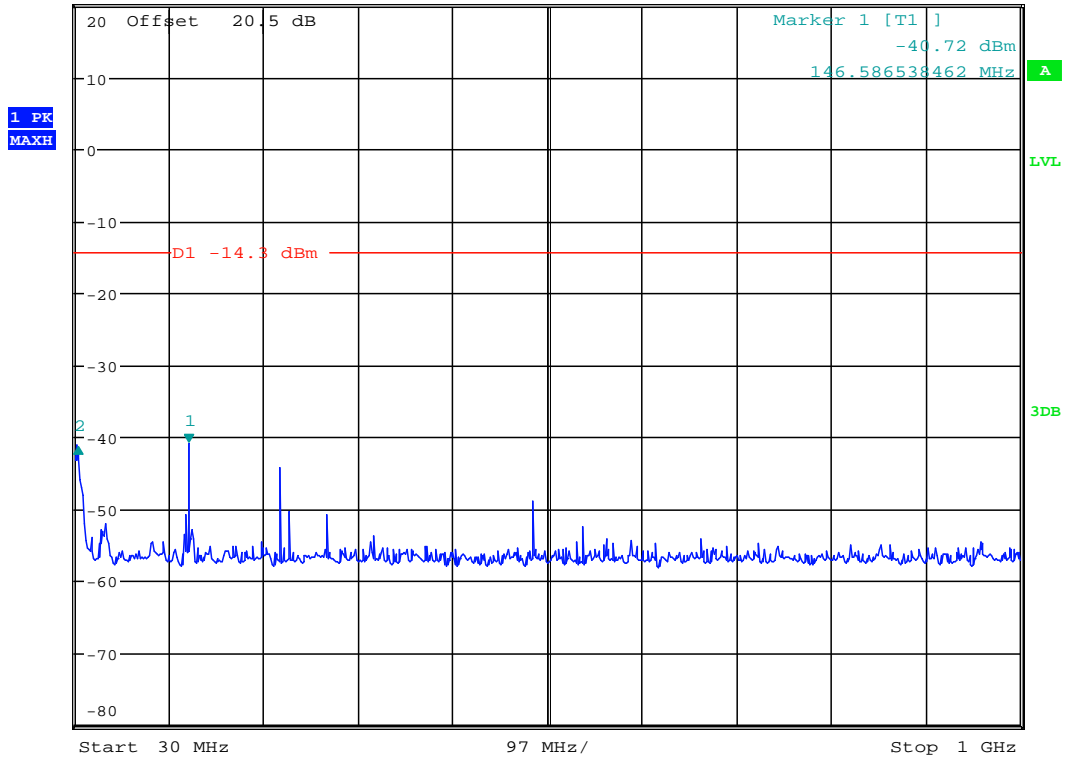

Ref 20 dBm *Att 10 dB *RBW 100 kHz Delta 2 [T1] -58.91 dB
 *VBW 300 kHz 7.115384615 GHz
 SWT 2.4 s

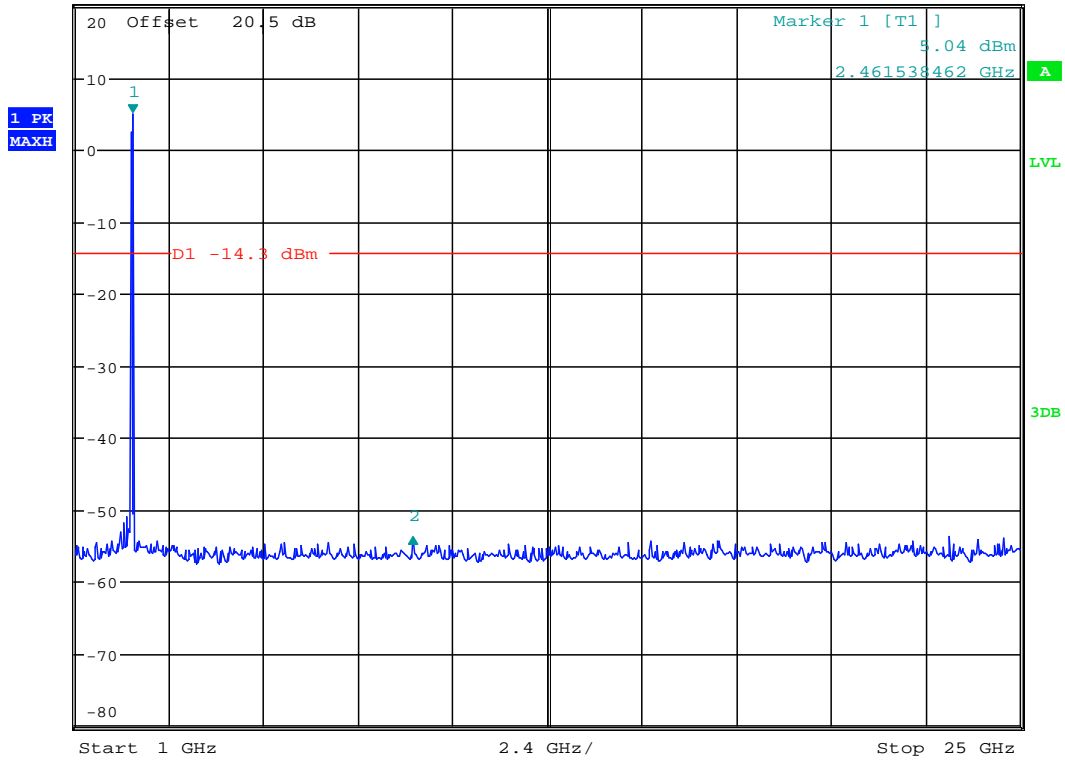

Chain 1 11g CH 1



Ref 20 dBm *Att 10 dB *RBW 100 kHz Marker 1 [T1]
*VBW 300 kHz 5.92 dBm
SWT 20 ms 2.418891026 GHz

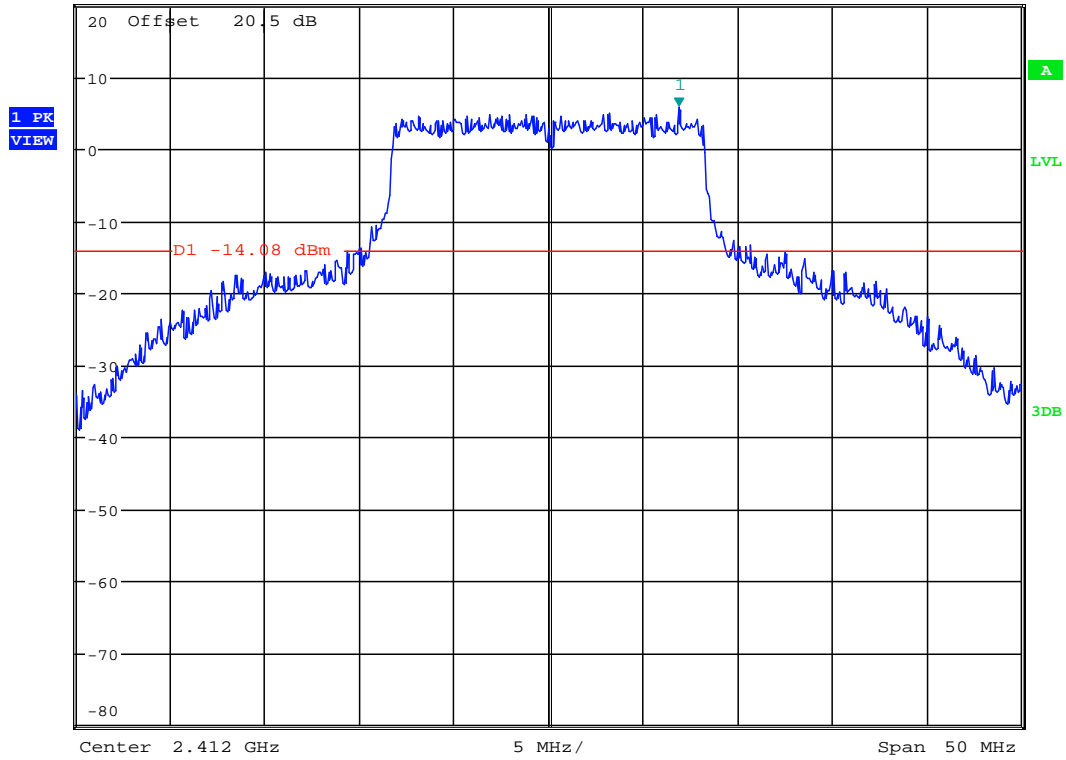

Ref 20 dBm *Att 10 dB *RBW 100 kHz Marker 2 [T1]
*VBW 300 kHz -17.67 dBm
SWT 15 ms 2.400000000 GHz

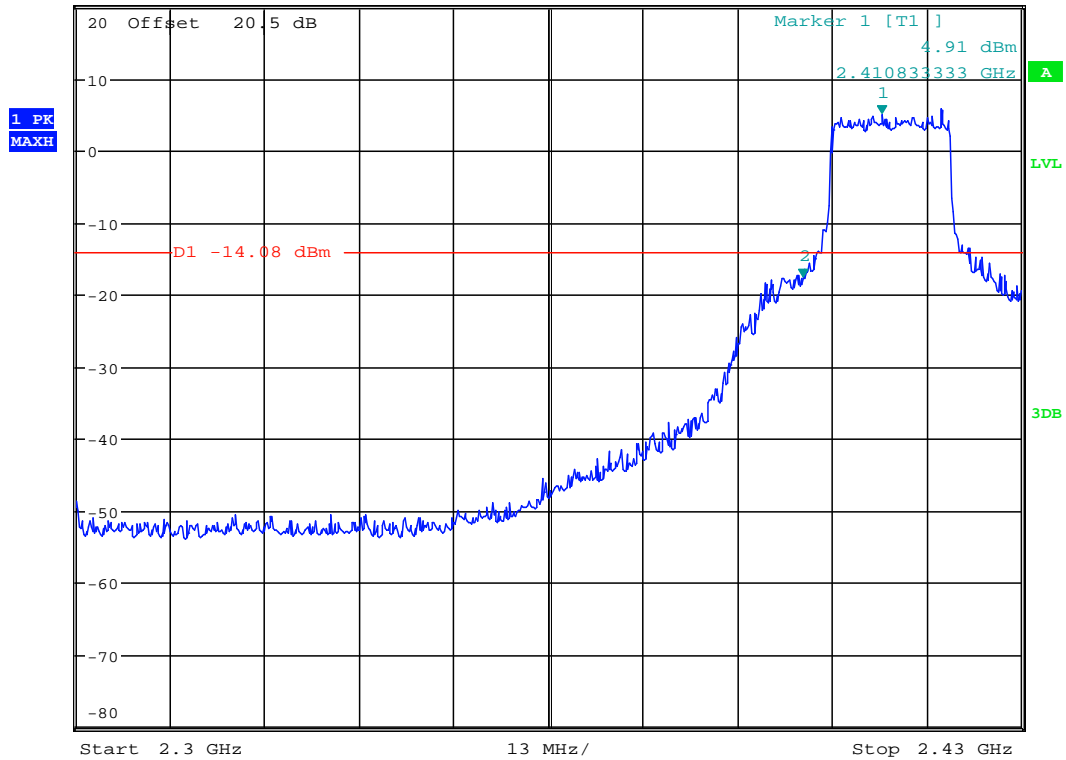



Ref 20 dBm *Att 10 dB *RBW 100 kHz Marker 1 [T1]
*VBW 300 kHz -41.53 dBm
SWT 100 ms 96.842948718 MHz

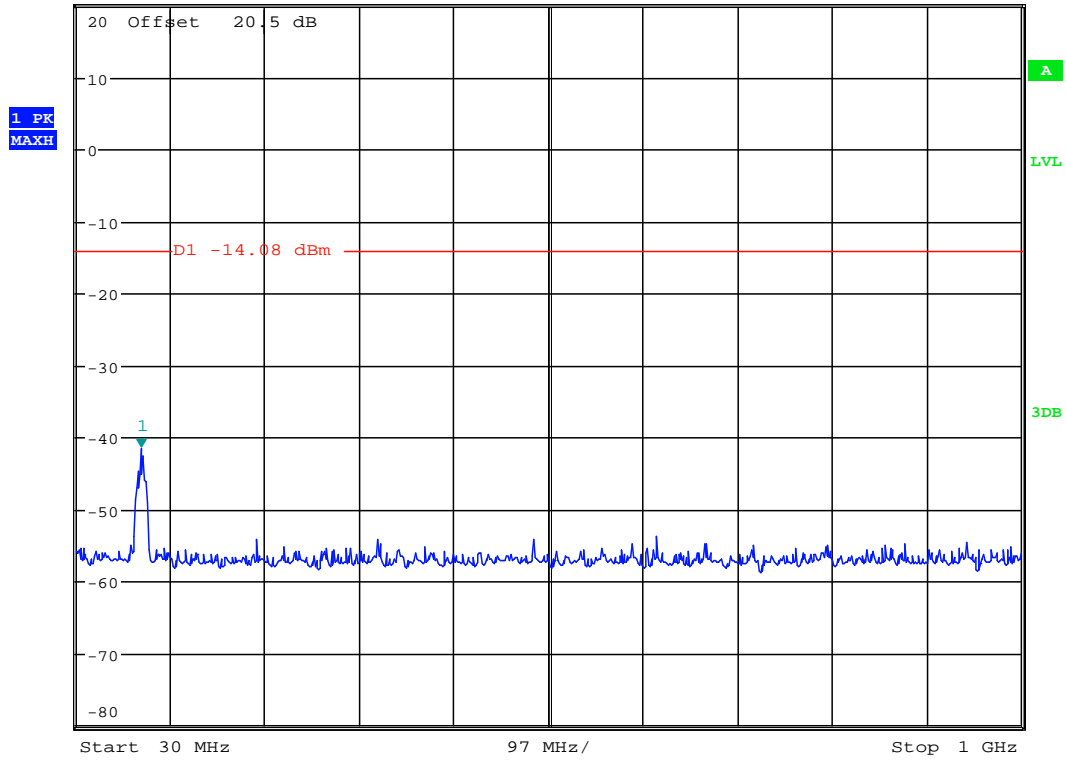

Ref 20 dBm *Att 10 dB *RBW 100 kHz Delta 2 [T1]
*VBW 300 kHz -54.25 dB
SWT 2.4 s 4.846153846 GHz

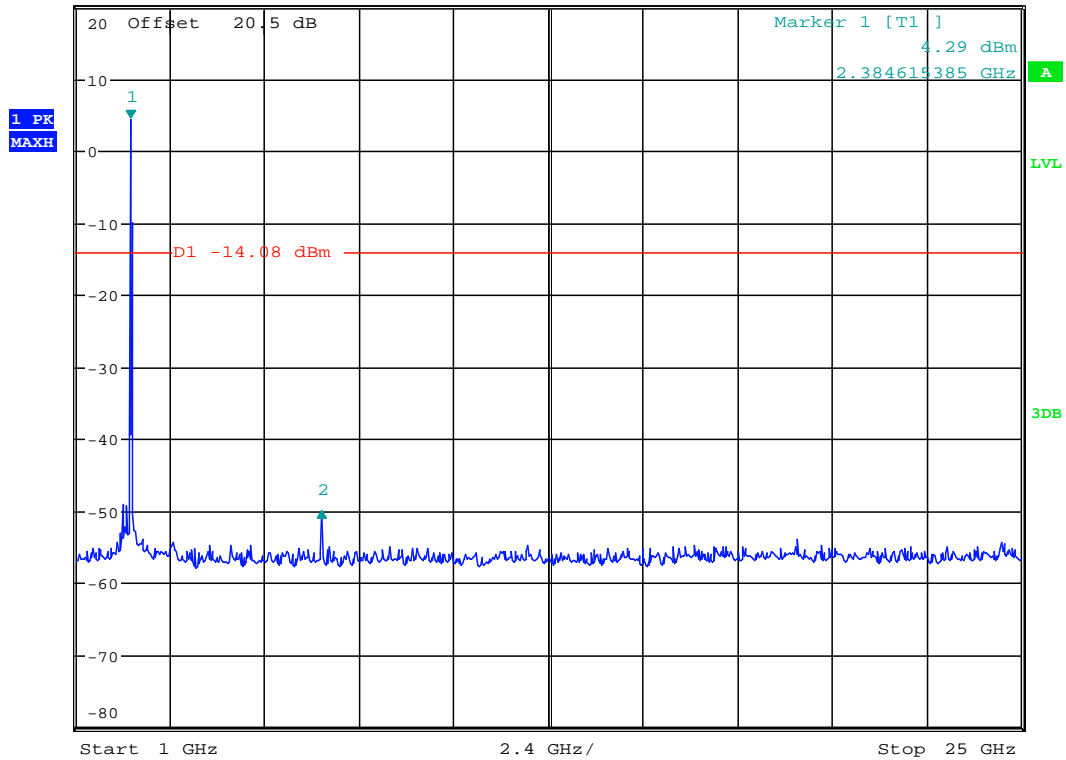

Chain 1 11g CH 6

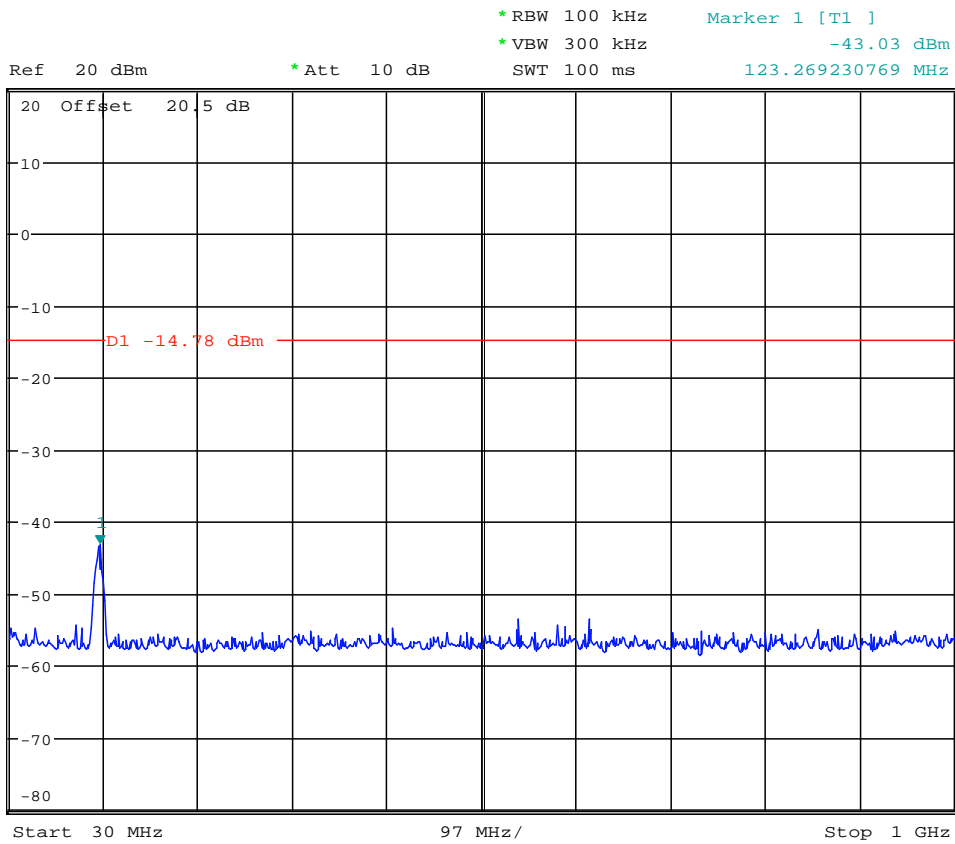
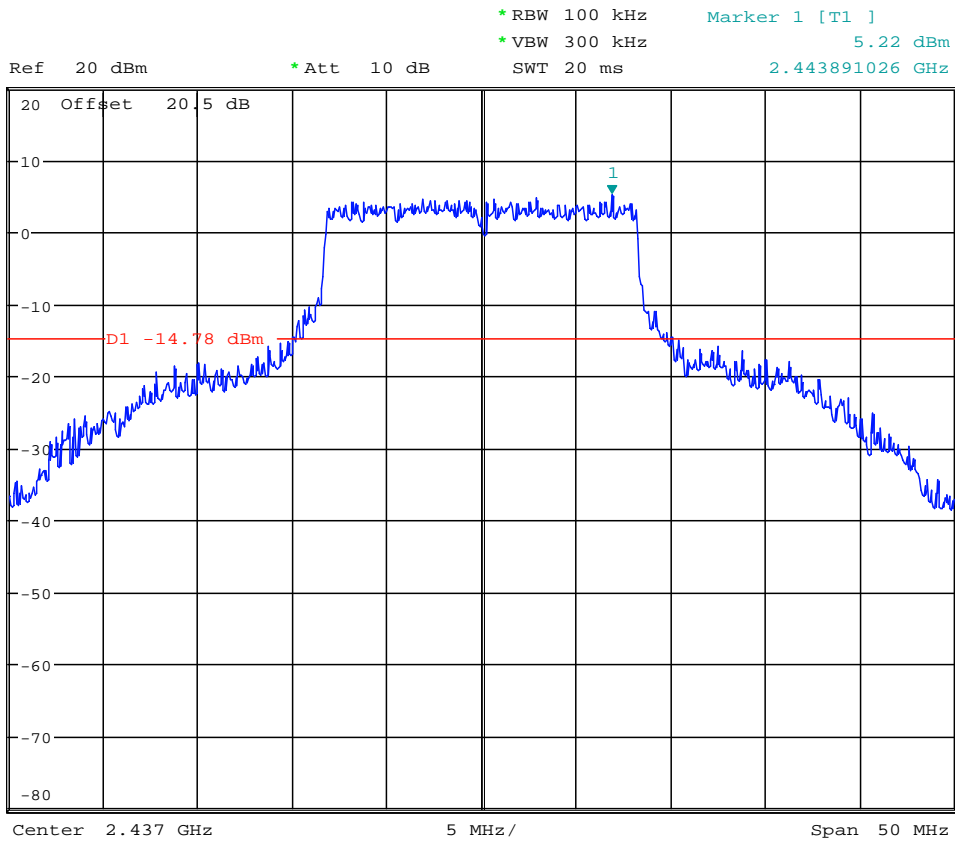

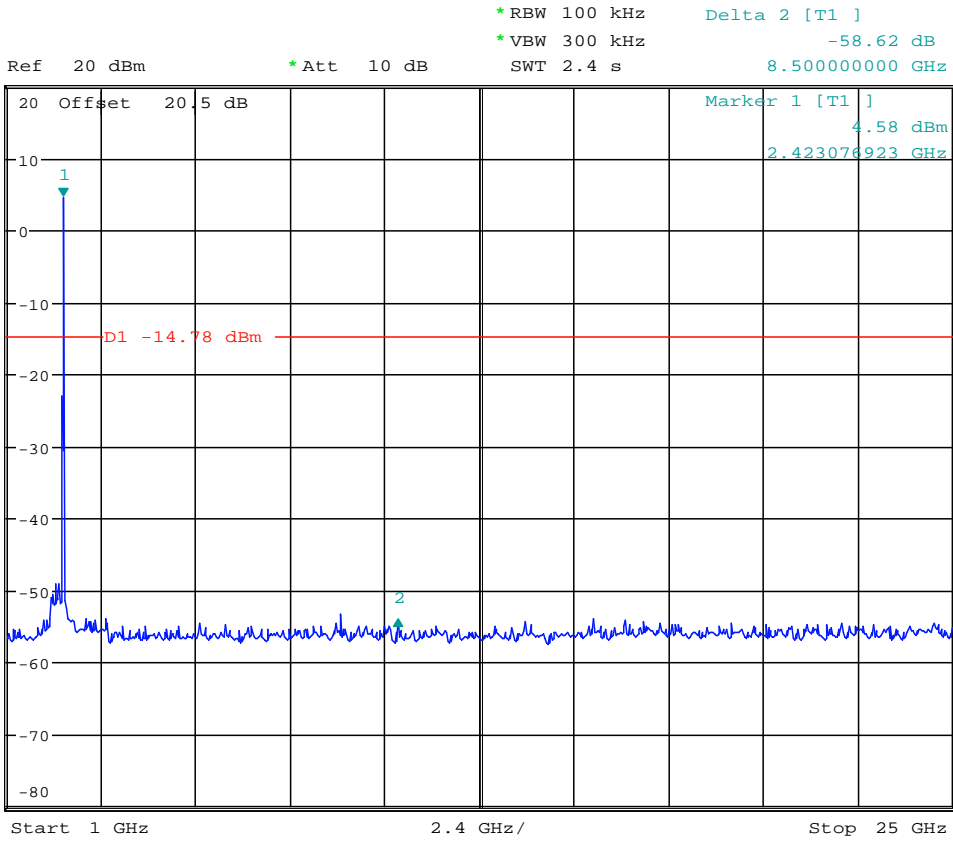

Chain 1 11g CH 11

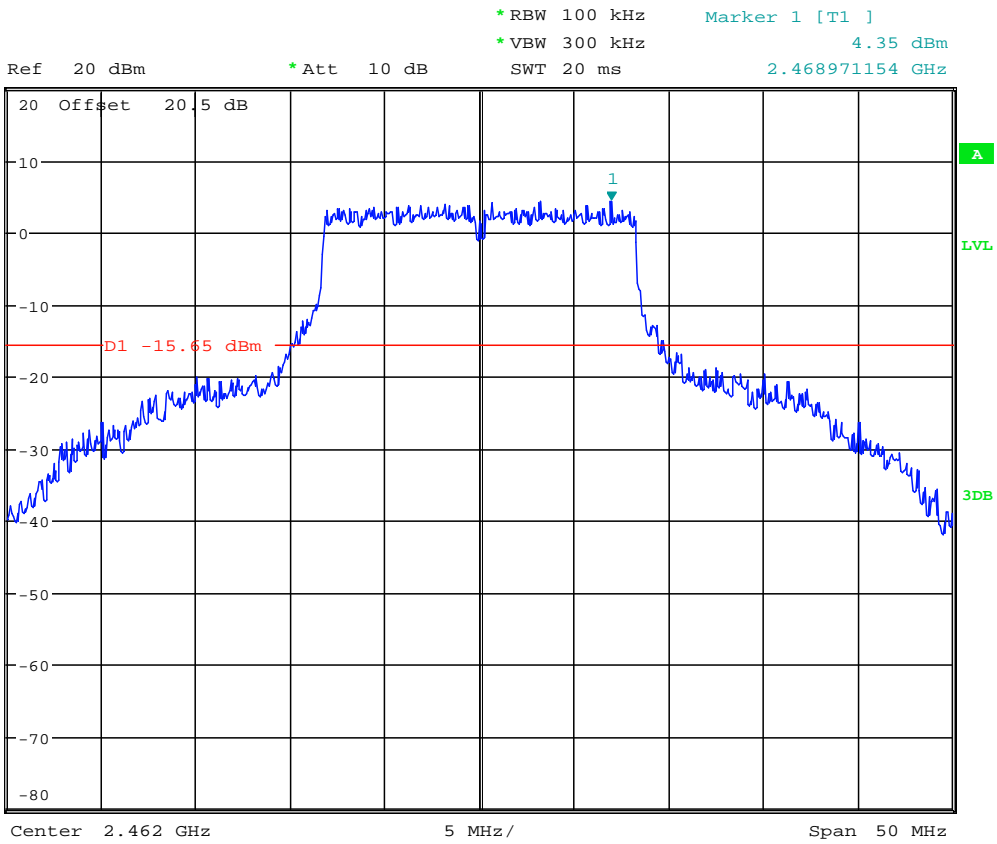



Ref 20 dBm *Att 10 dB *RBW 100 kHz Marker 2 [T1]
-30.73 dBm
*VBW 300 kHz
SWT 15 ms 2.483500000 GHz

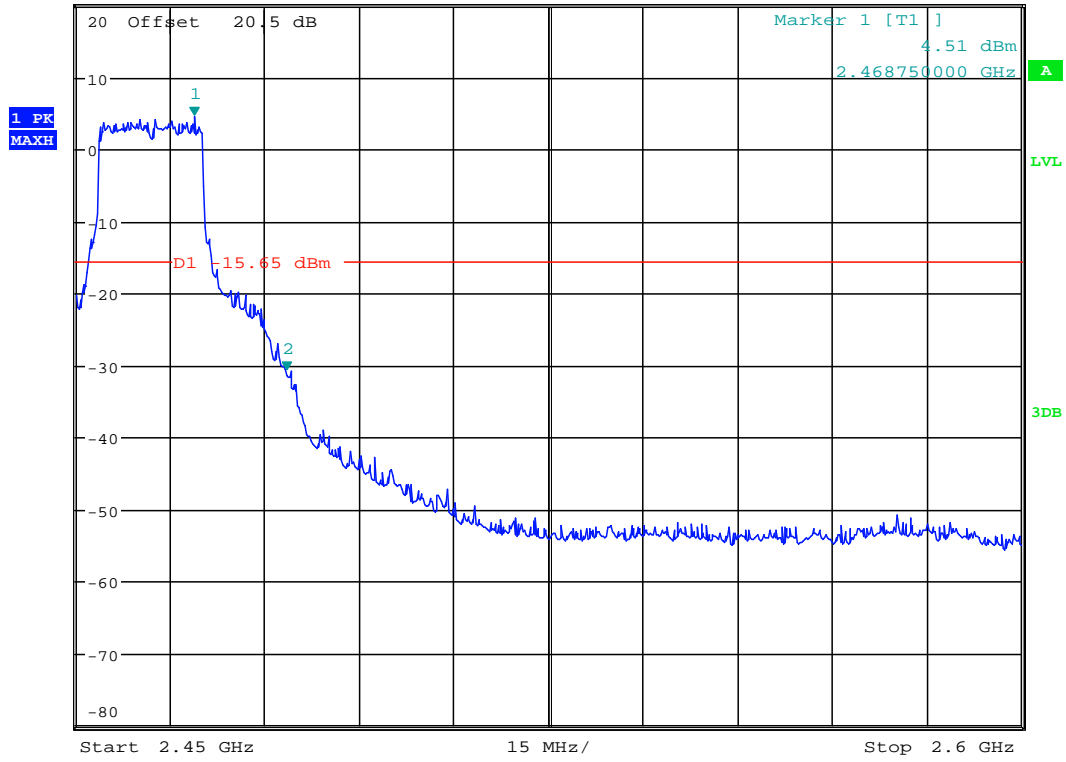

Ref 20 dBm *Att 10 dB *RBW 100 kHz Marker 1 [T1]
-44.92 dBm
*VBW 300 kHz
SWT 100 ms 148.141025641 MHz

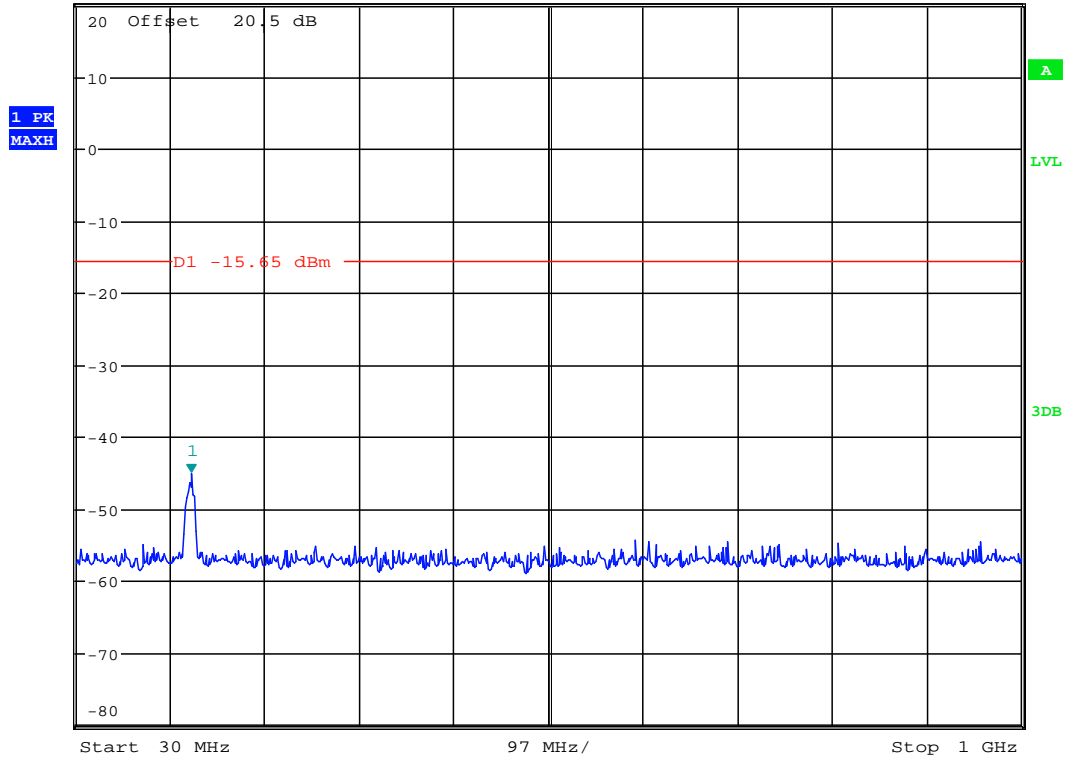

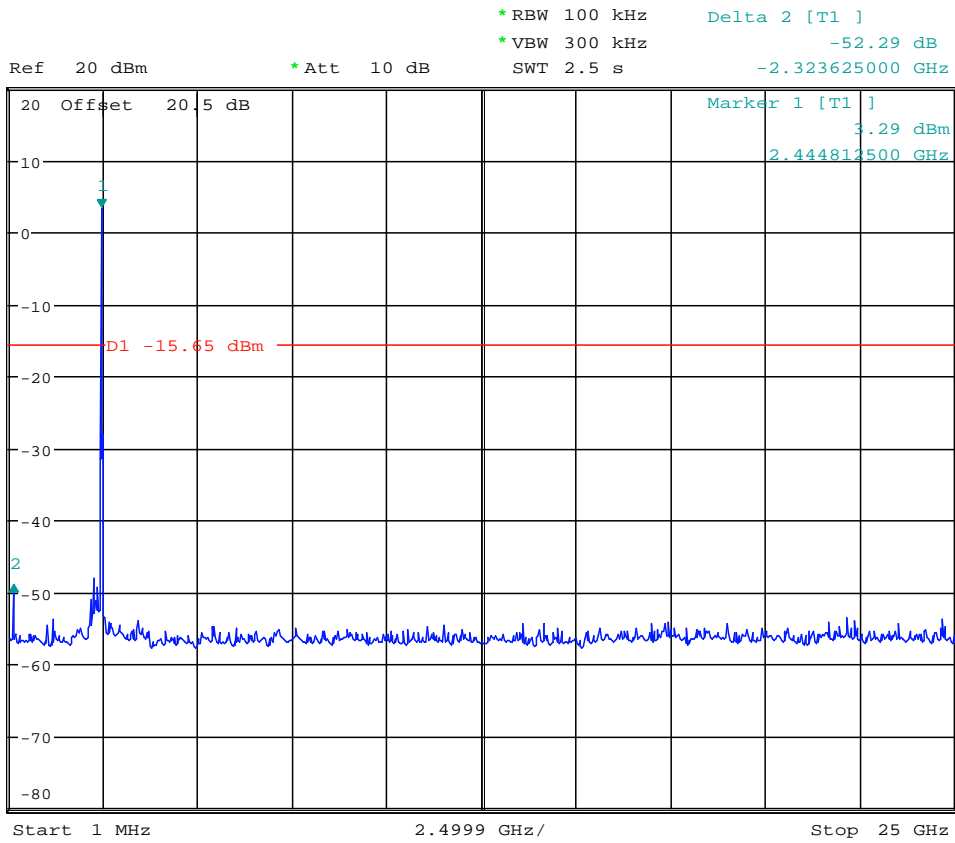

Chain 1 11n HT20 CH 1

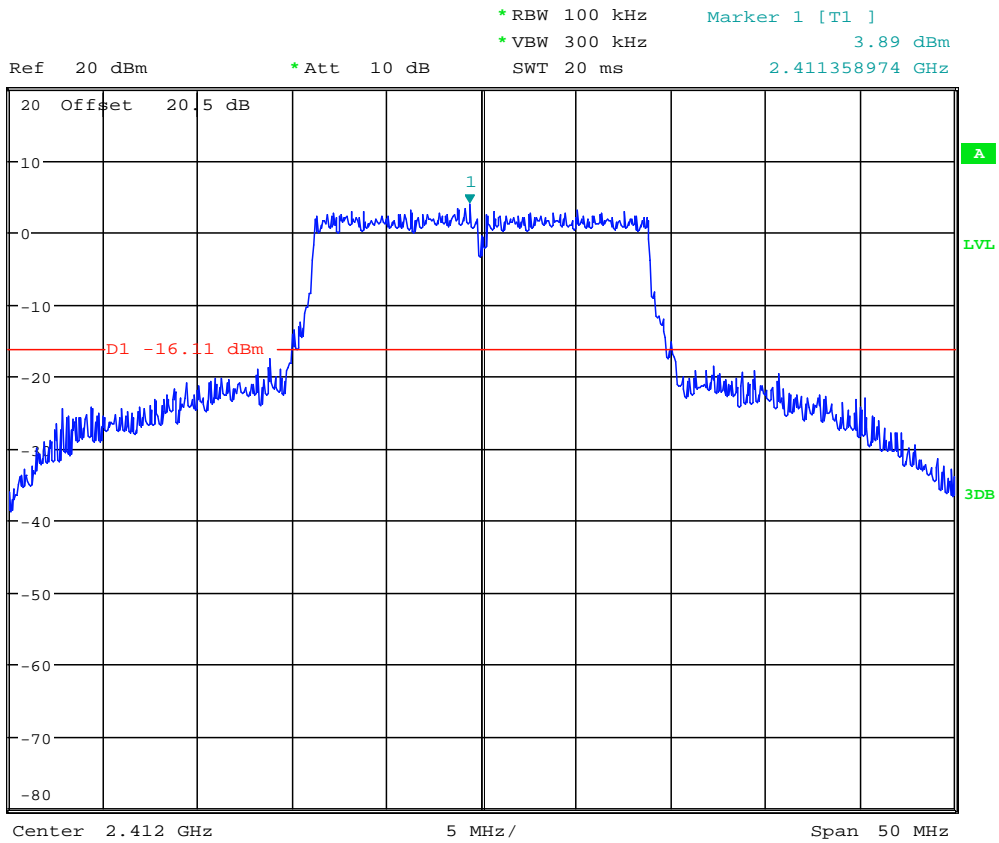



1 PK
MAXH

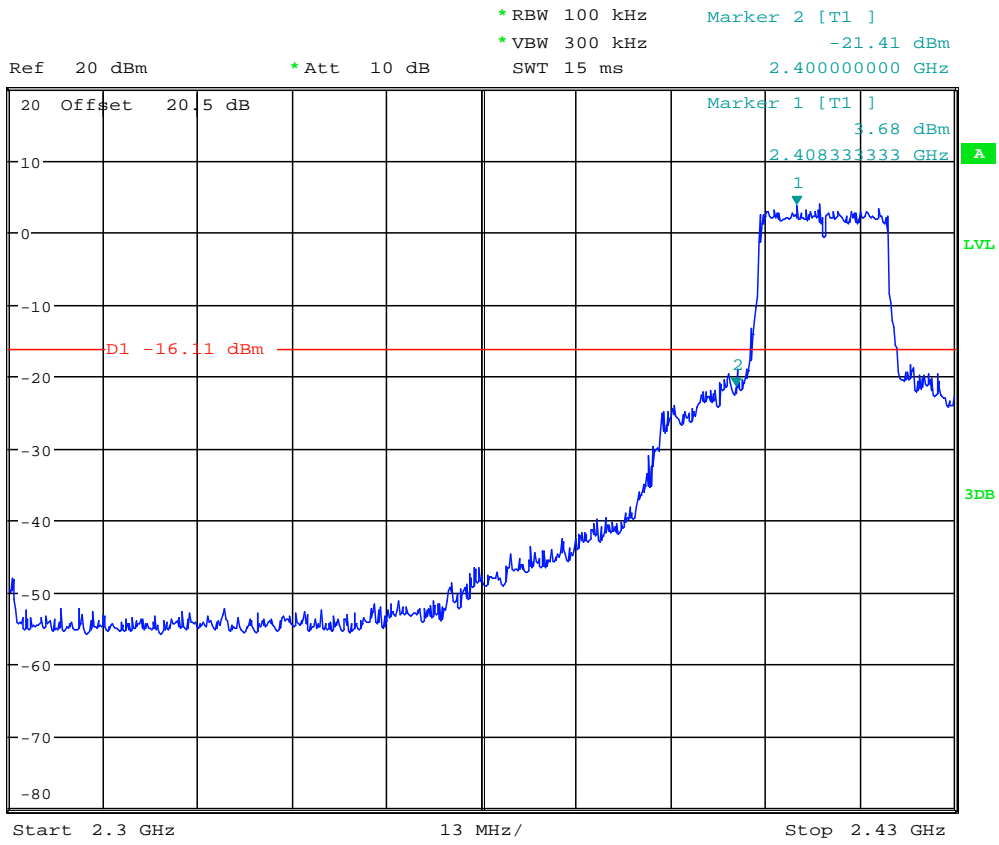

1 PK
MAXH

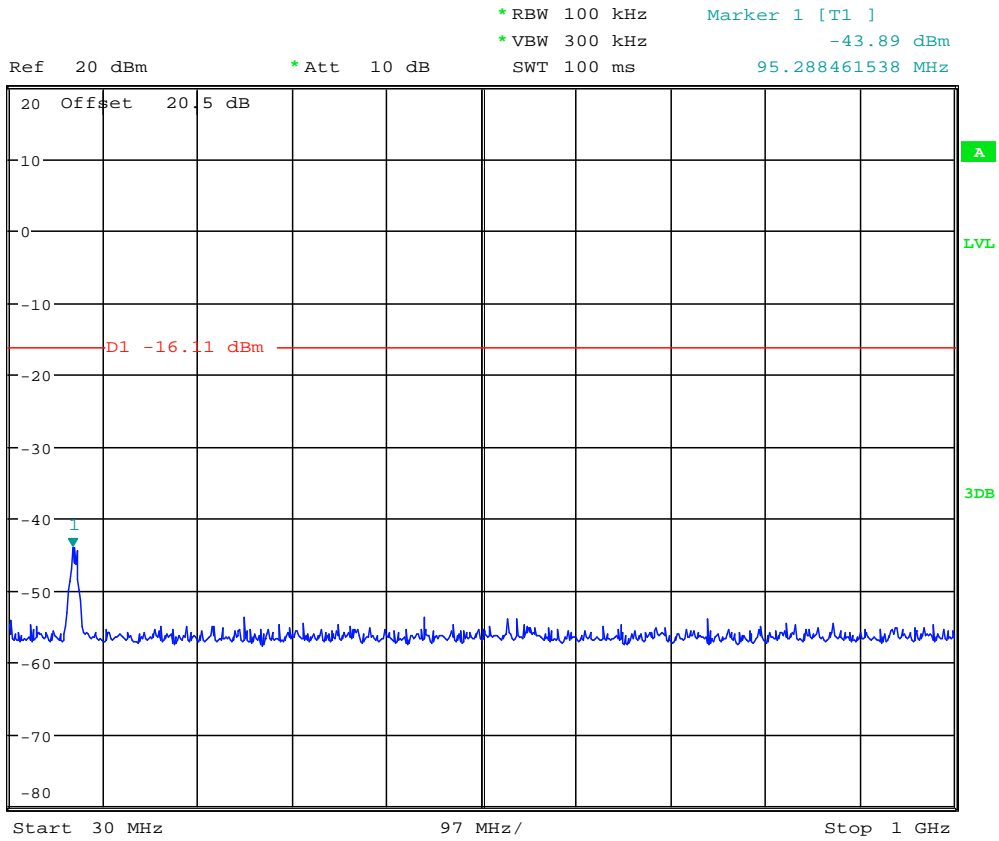

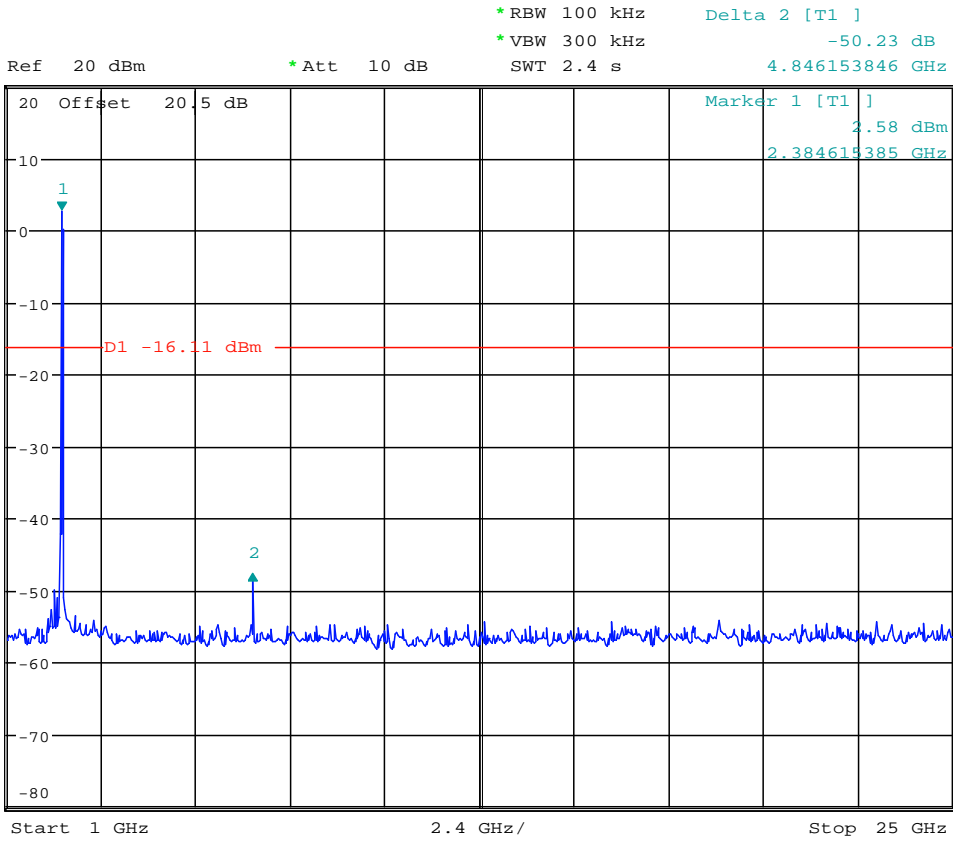

Chain 1 11n HT20 CH 6

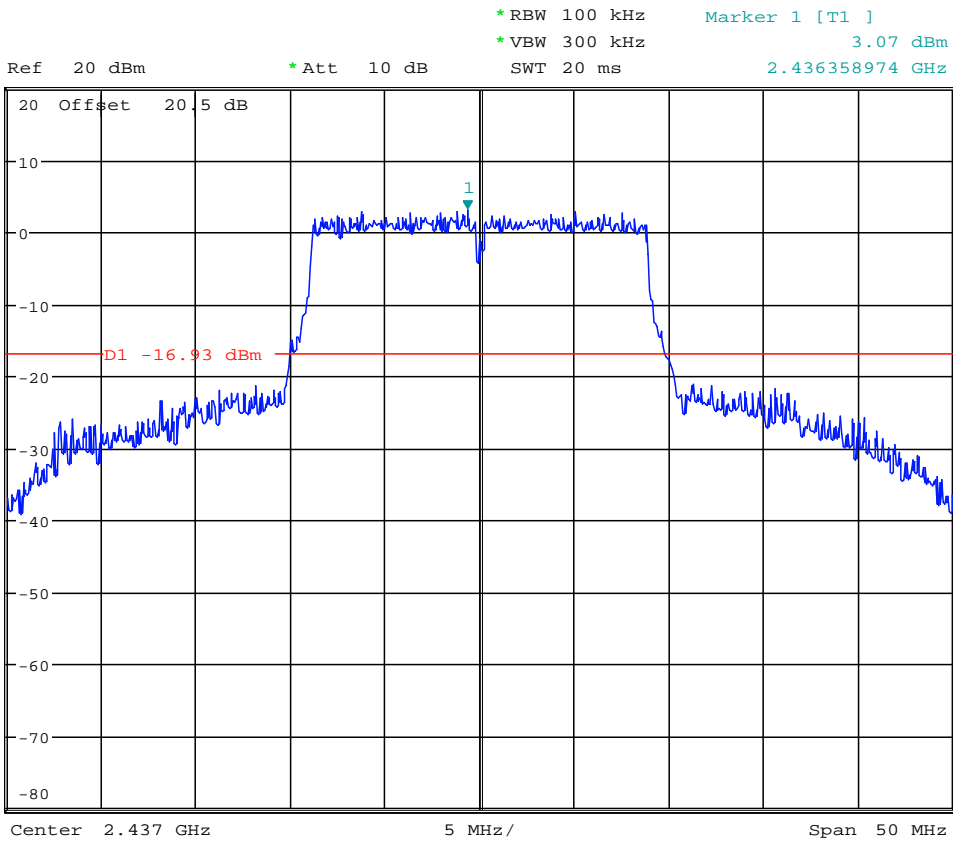



Ref 20 dBm *Att 10 dB *RBW 100 kHz Marker 1 [T1]
*VBW 300 kHz -47.82 dBm
SWT 100 ms 121.714743590 MHz

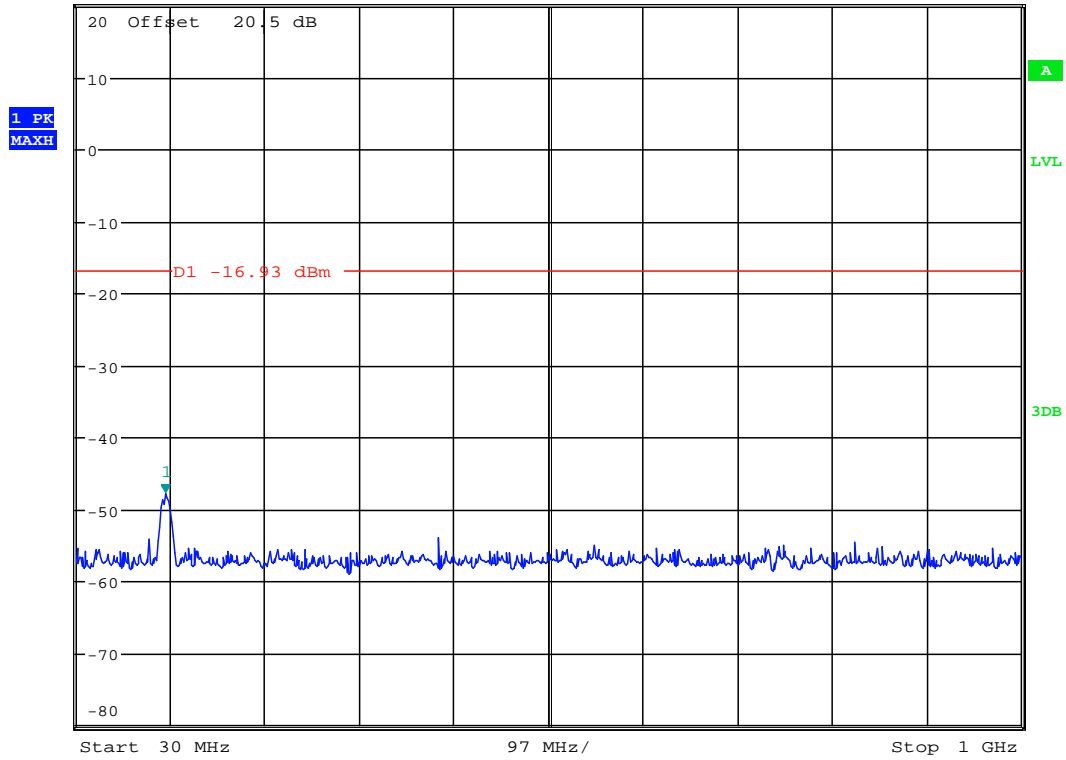

Ref 20 dBm *Att 10 dB *RBW 100 kHz Delta 2 [T1]
*VBW 300 kHz -55.96 dB
SWT 2.4 s 16.076923077 GHz

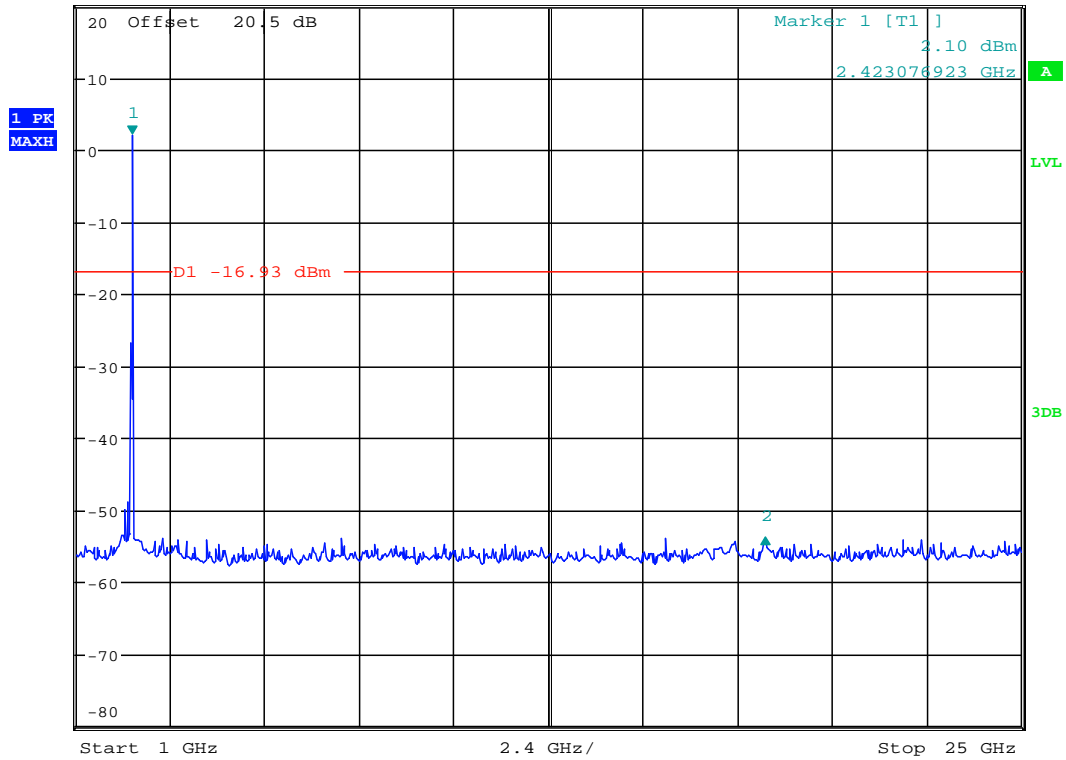

Chain 1 11n HT20 CH 11



Ref 20 dBm *Att 10 dB *RBW 100 kHz Marker 1 [T1]
*VBW 300 kHz 2.64 dBm
SWT 20 ms 2.461358974 GHz

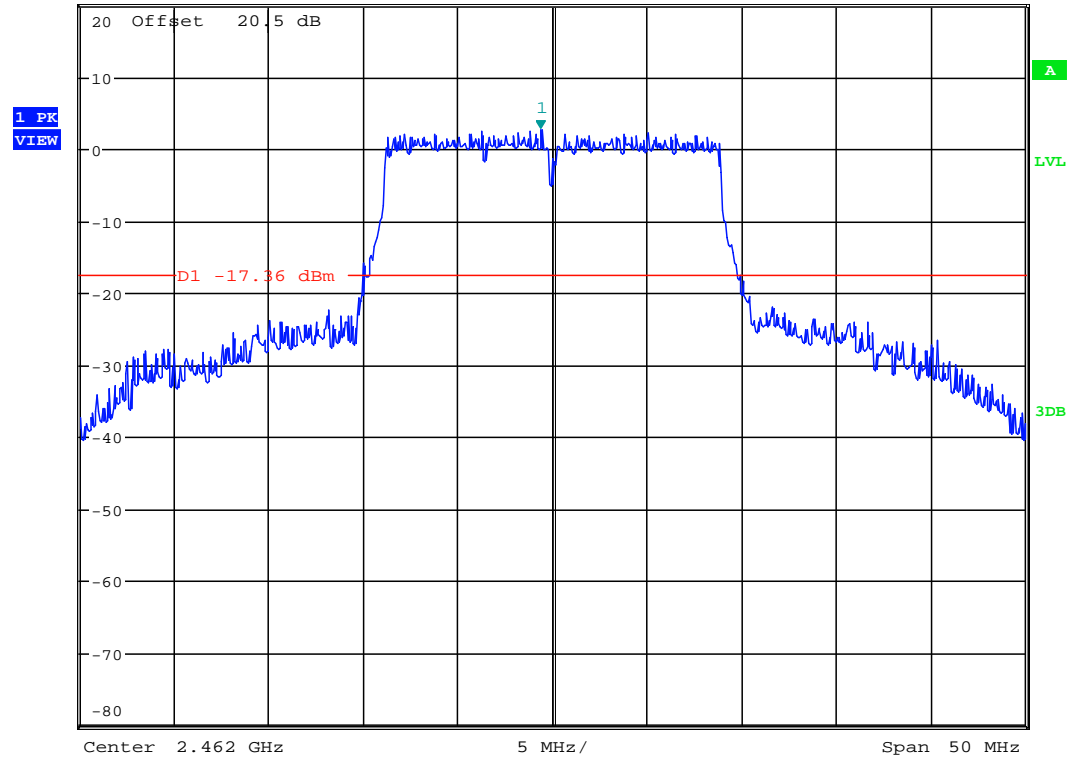

Ref 20 dBm *Att 10 dB *RBW 100 kHz Marker 2 [T1]
*VBW 300 kHz -31.21 dBm
SWT 15 ms 2.483500000 GHz

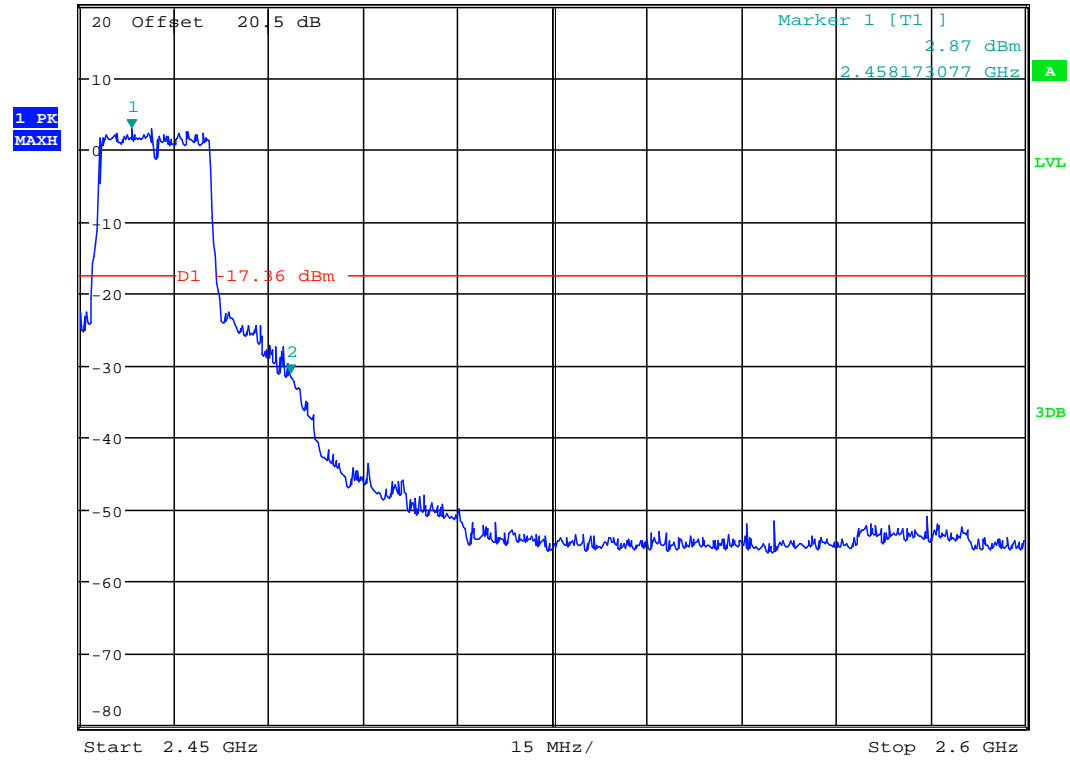



Ref 20 dBm *Att 10 dB *RBW 100 kHz Marker 1 [T1]
*VBW 300 kHz -47.03 dBm
SWT 100 ms 149.695512821 MHz

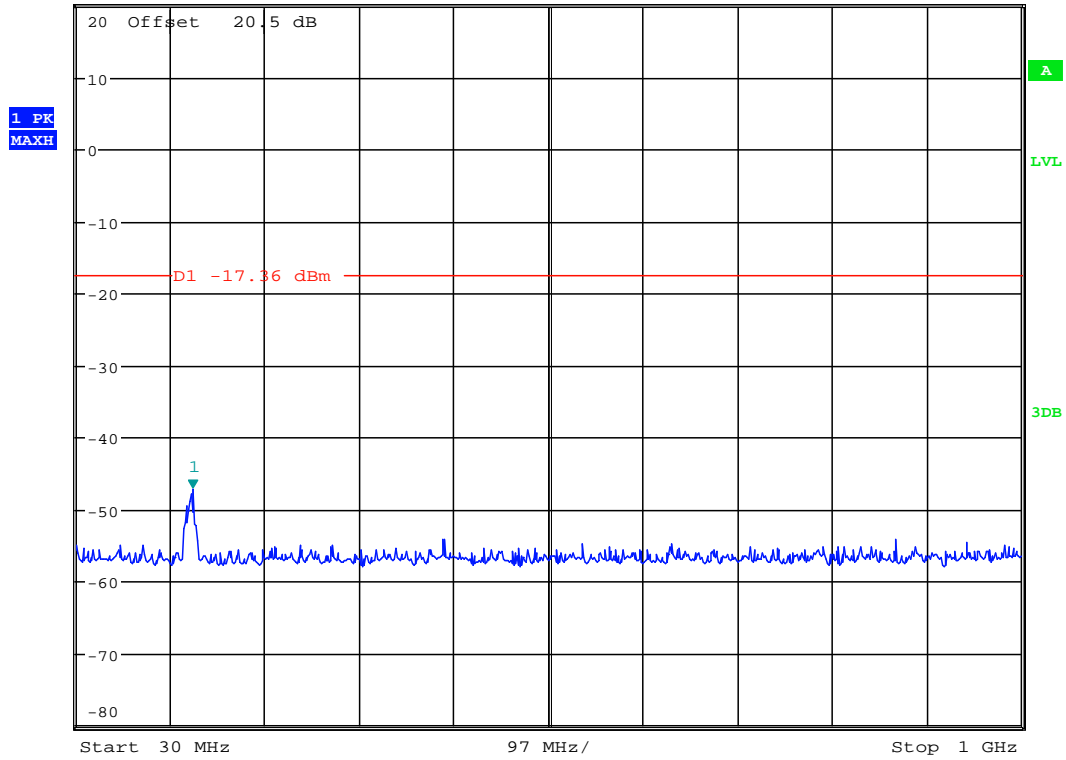

Ref 20 dBm *Att 10 dB *RBW 100 kHz Delta 2 [T1]
*VBW 300 kHz -56.26 dB
SWT 2.4 s 2.846153846 GHz

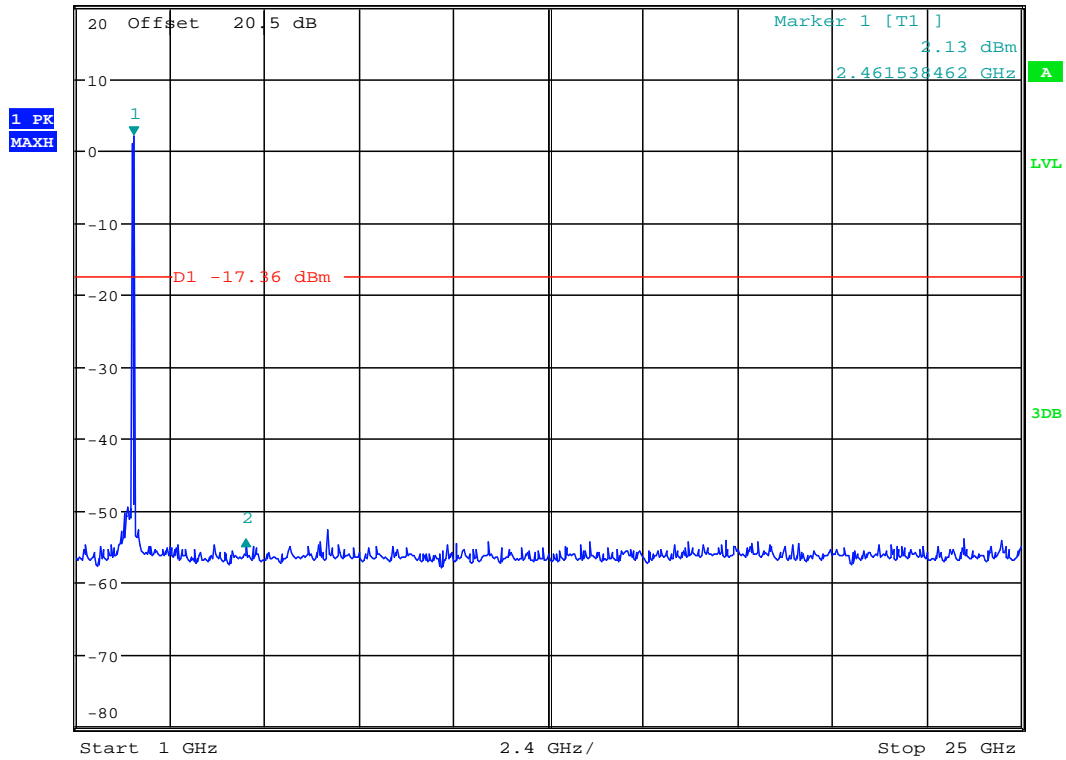

Chain 1 11n HT40 CH 3



Ref 20 dBm *Att 10 dB *RBW 100 kHz Marker 1 [T1]
*VBW 300 kHz 7.46 dBm
SWT 20 ms 2.409836538 GHz

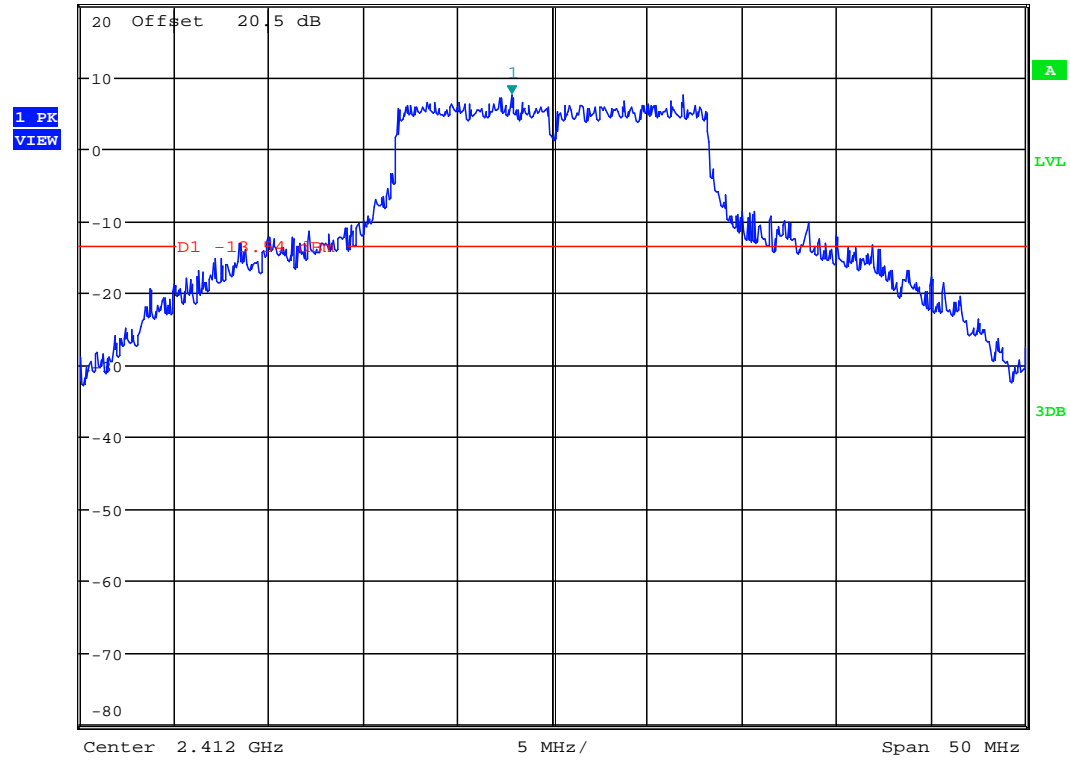

Ref 20 dBm *Att 10 dB *RBW 100 kHz Marker 2 [T1]
*VBW 300 kHz -15.73 dBm
SWT 15 ms 2.400000000 GHz

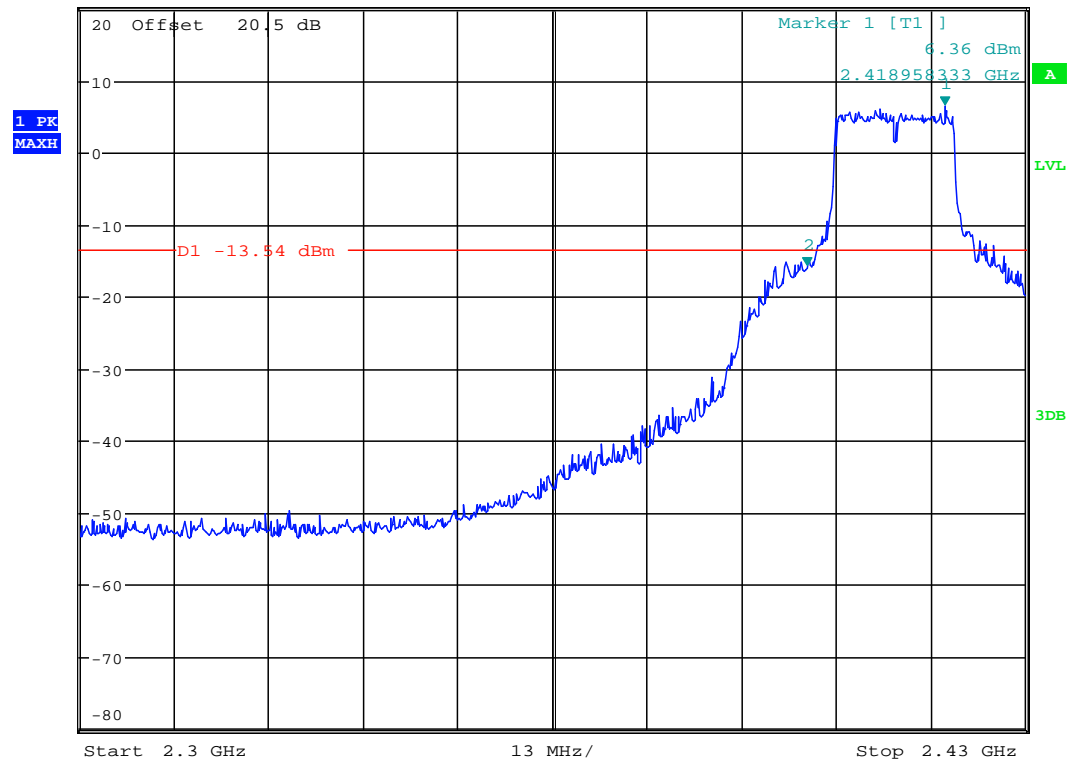



Ref 20 dBm *Att 10 dB *RBW 100 kHz Marker 1 [T1]
*VBW 300 kHz -39.70 dBm
SWT 100 ms 99.951923077 MHz

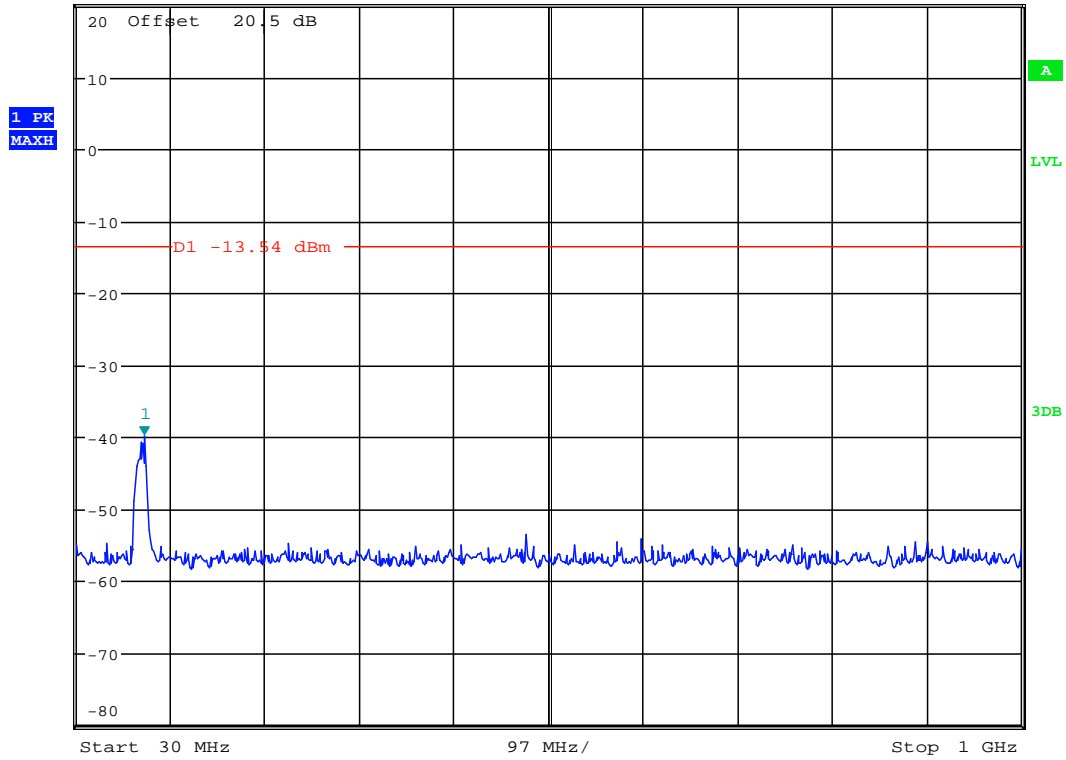

Ref 20 dBm *Att 10 dB *RBW 100 kHz Delta 2 [T1]
*VBW 300 kHz -59.96 dB
SWT 2.4 s 9.038461538 GHz

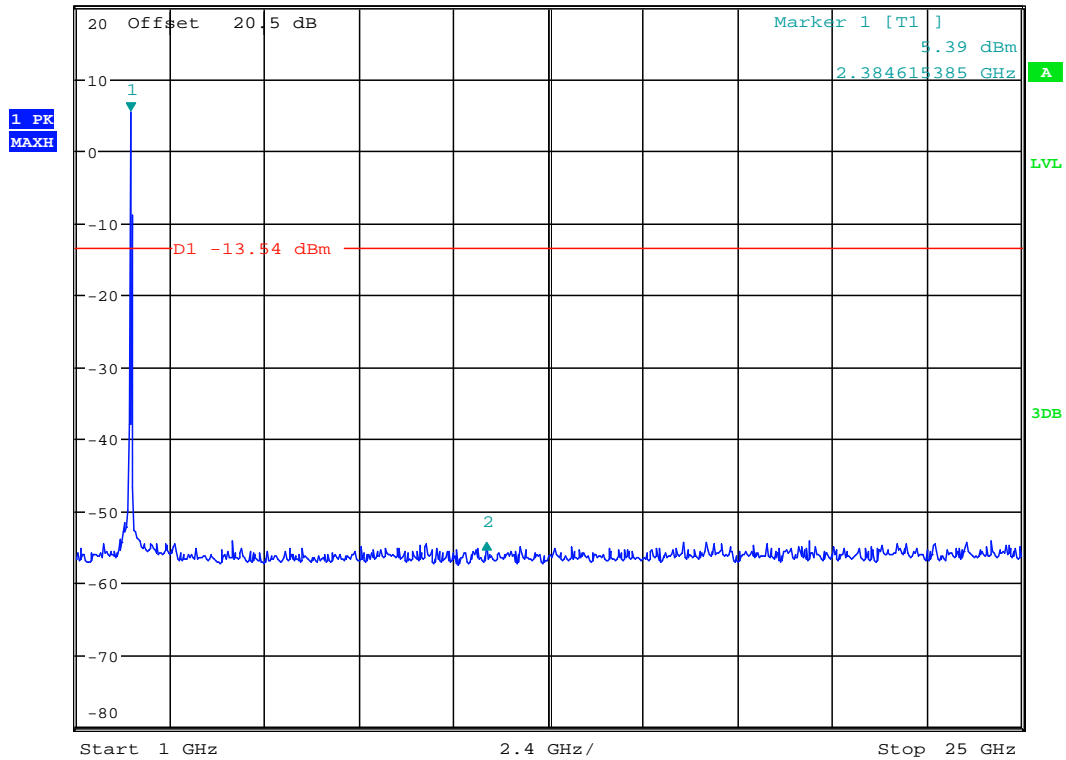

Chain 1 11n HT40 CH 6



Ref 20 dBm *Att 10 dB *RBW 100 kHz Marker 1 [T1]
*VBW 300 kHz -1.89 dBm
SWT 10 ms 2.426423077 GHz

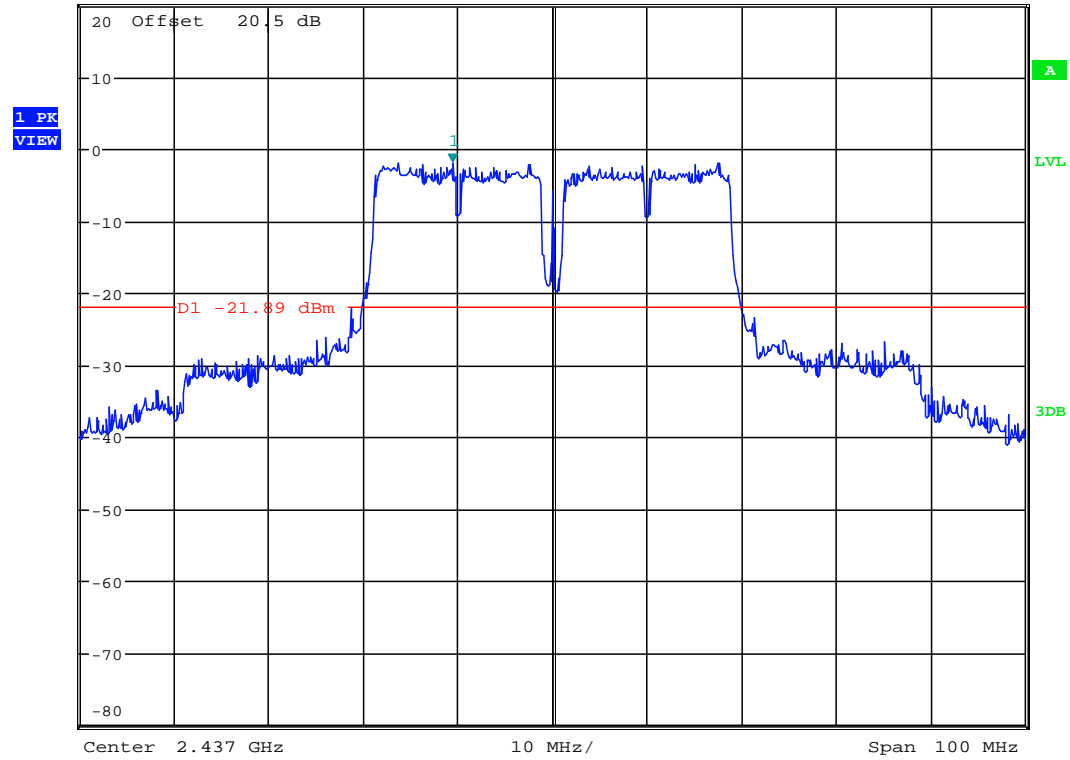

Ref 20 dBm *Att 10 dB *RBW 100 kHz Marker 1 [T1]
*VBW 300 kHz -49.60 dBm
SWT 100 ms 123.269230769 MHz

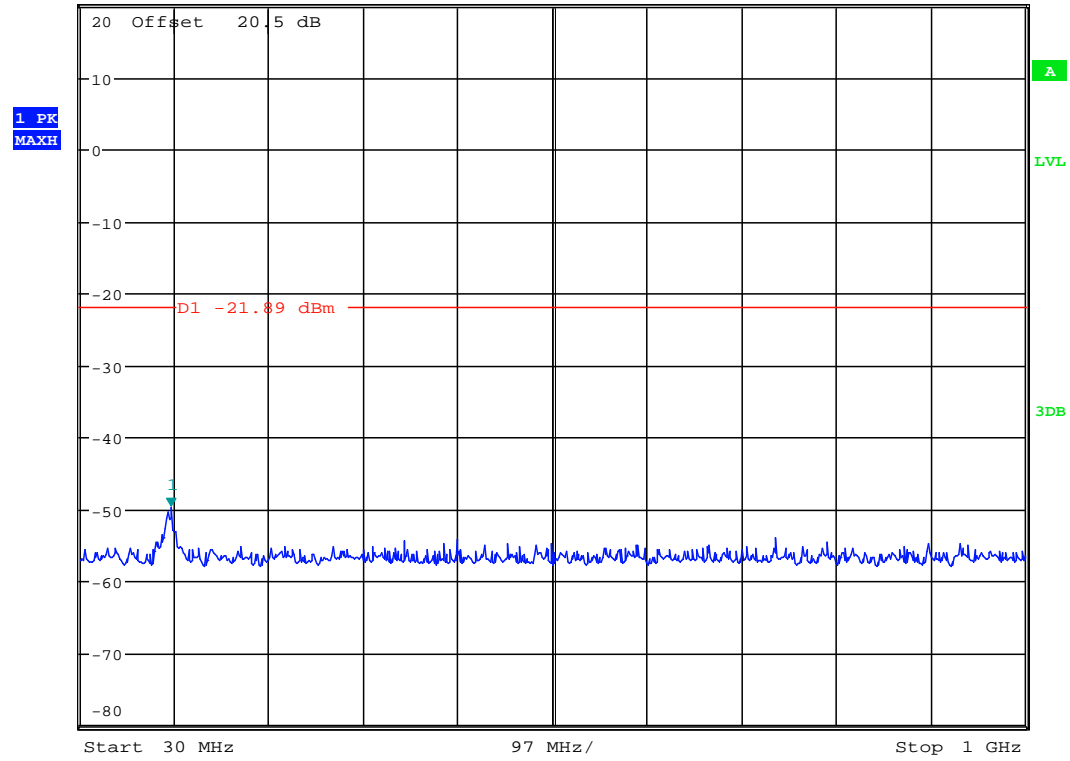

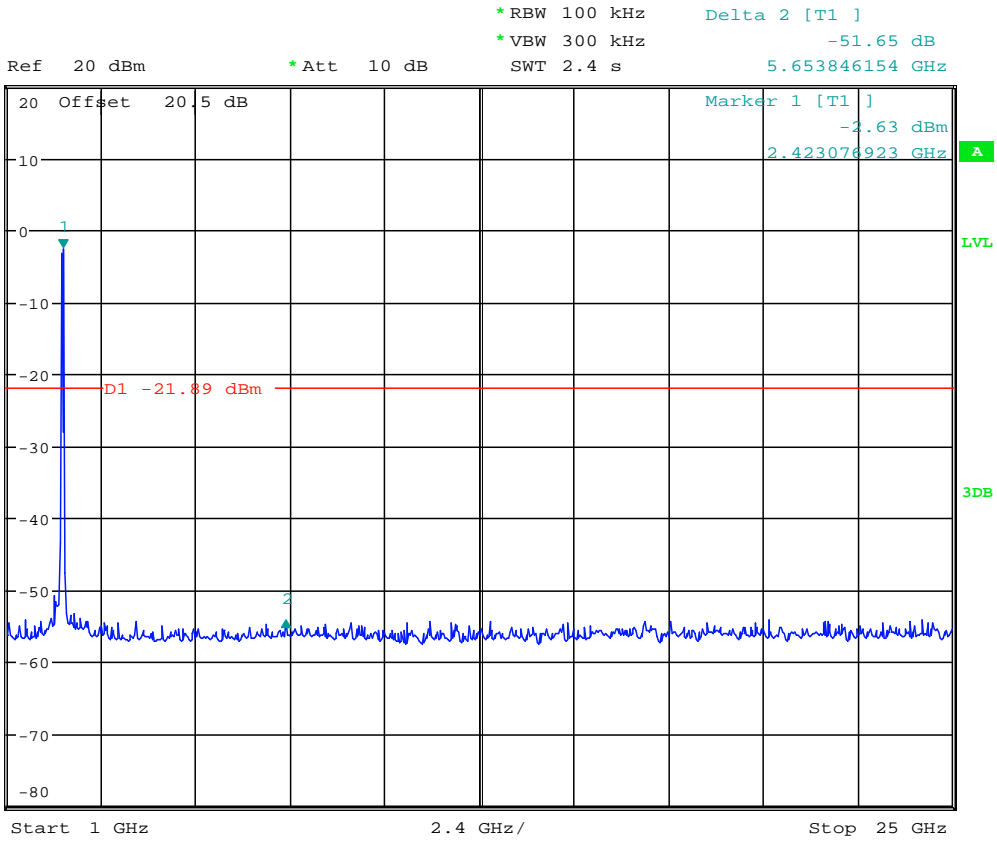

Chain 1 11n HT40 CH 9

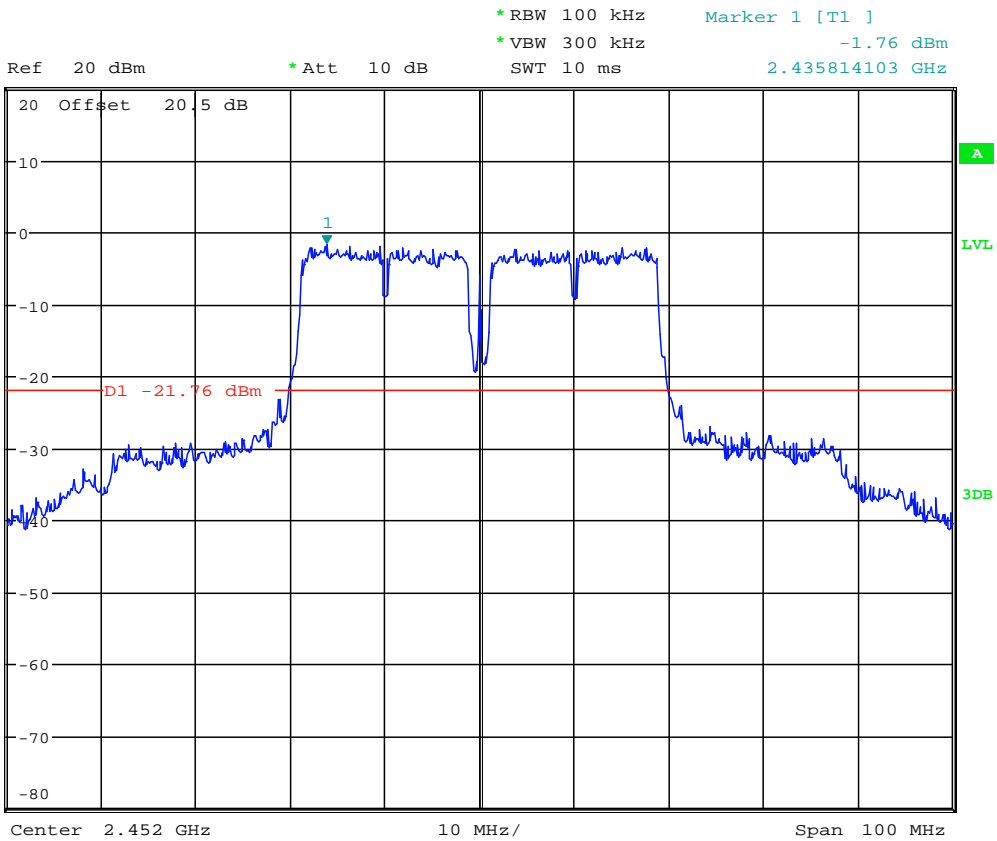

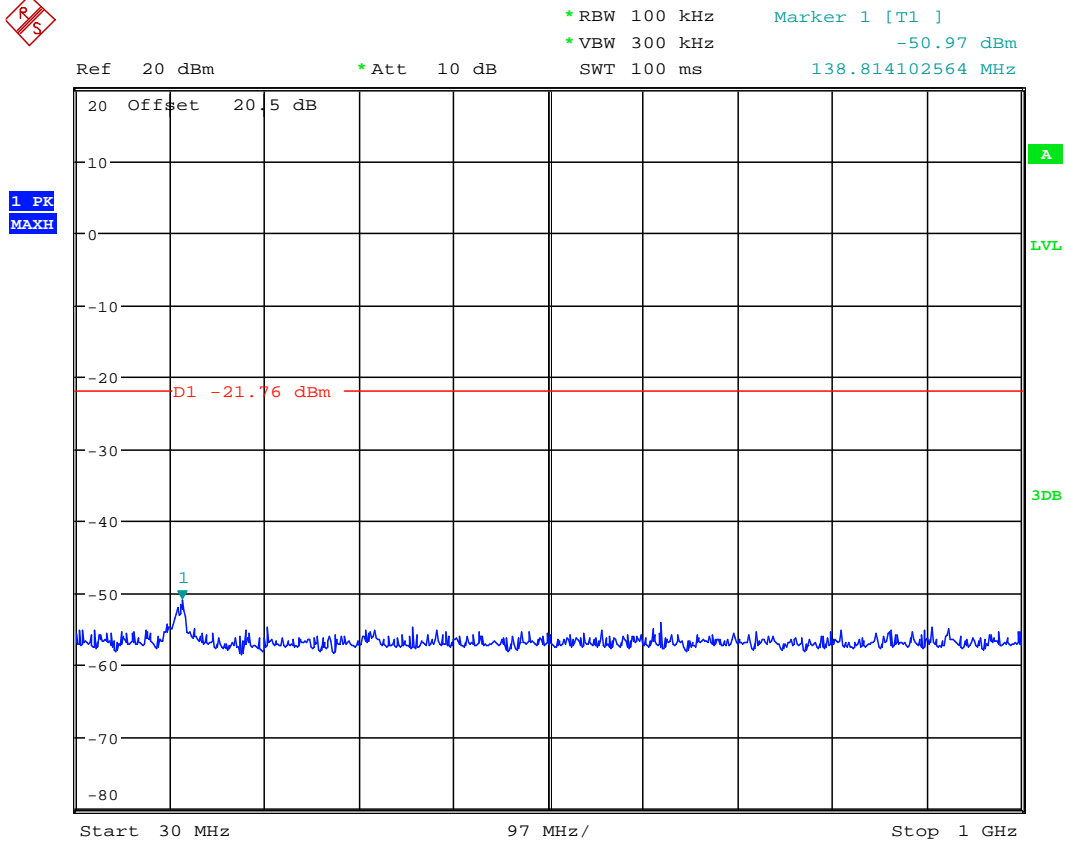
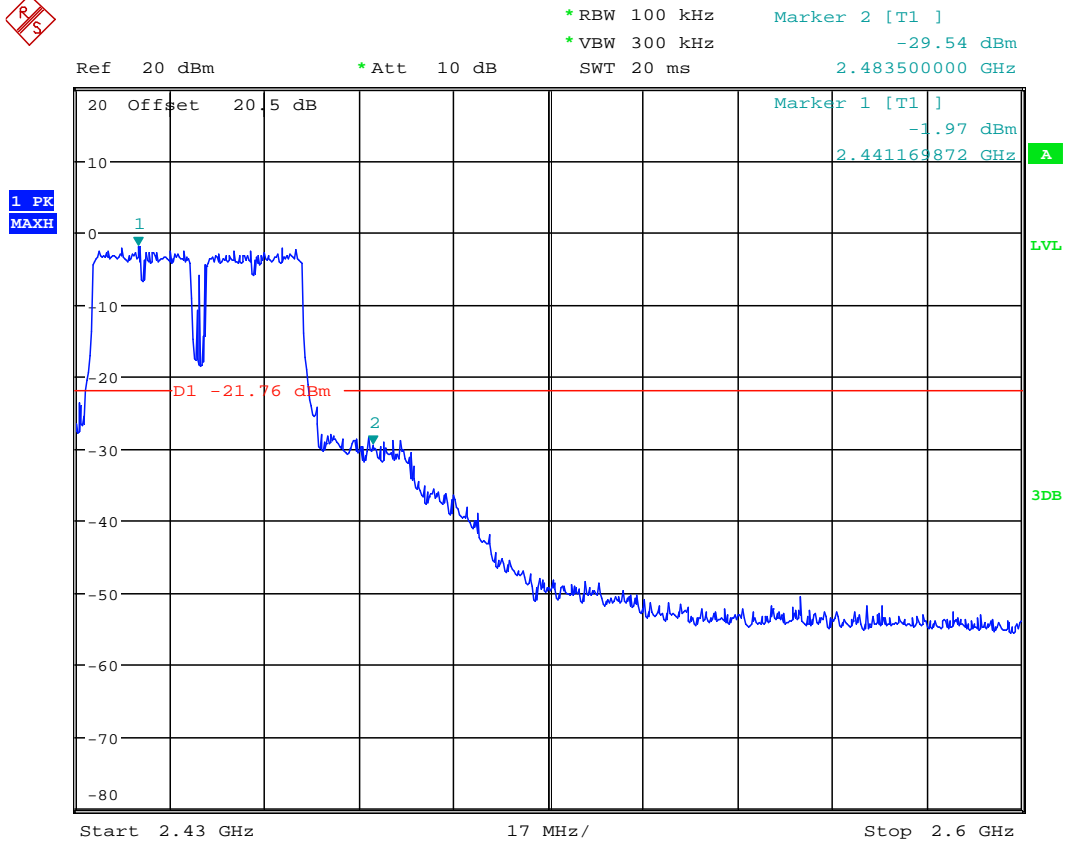

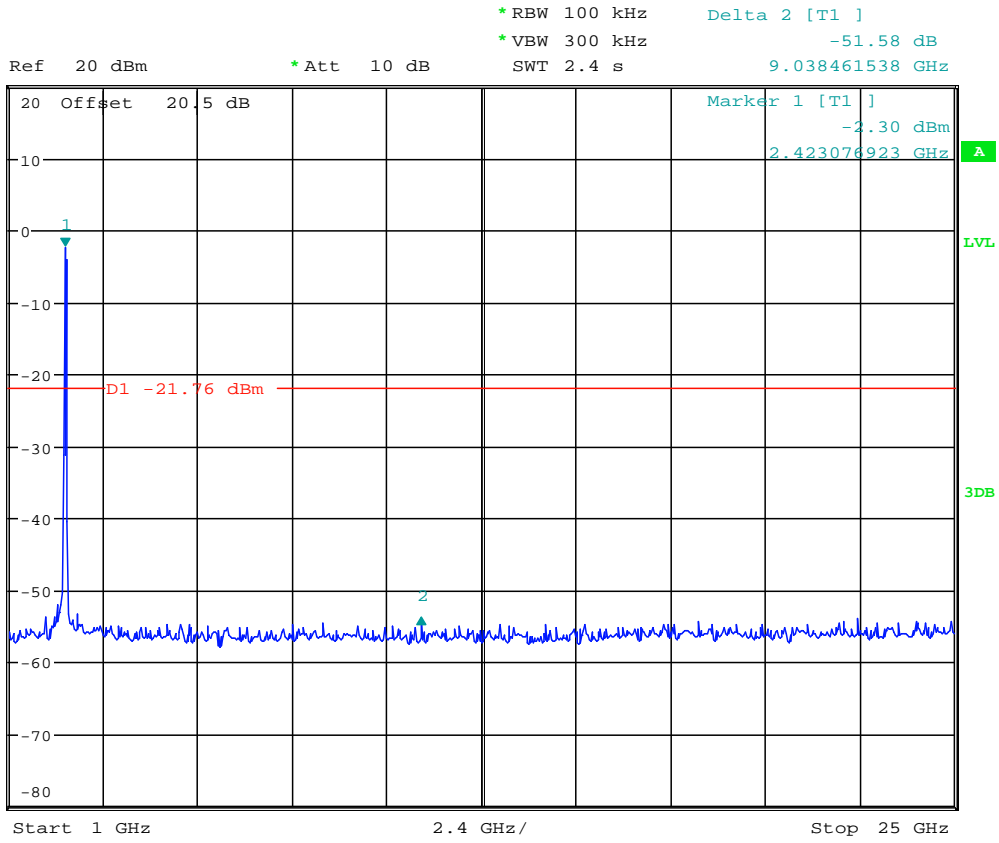

Chain 2 11b CH 1

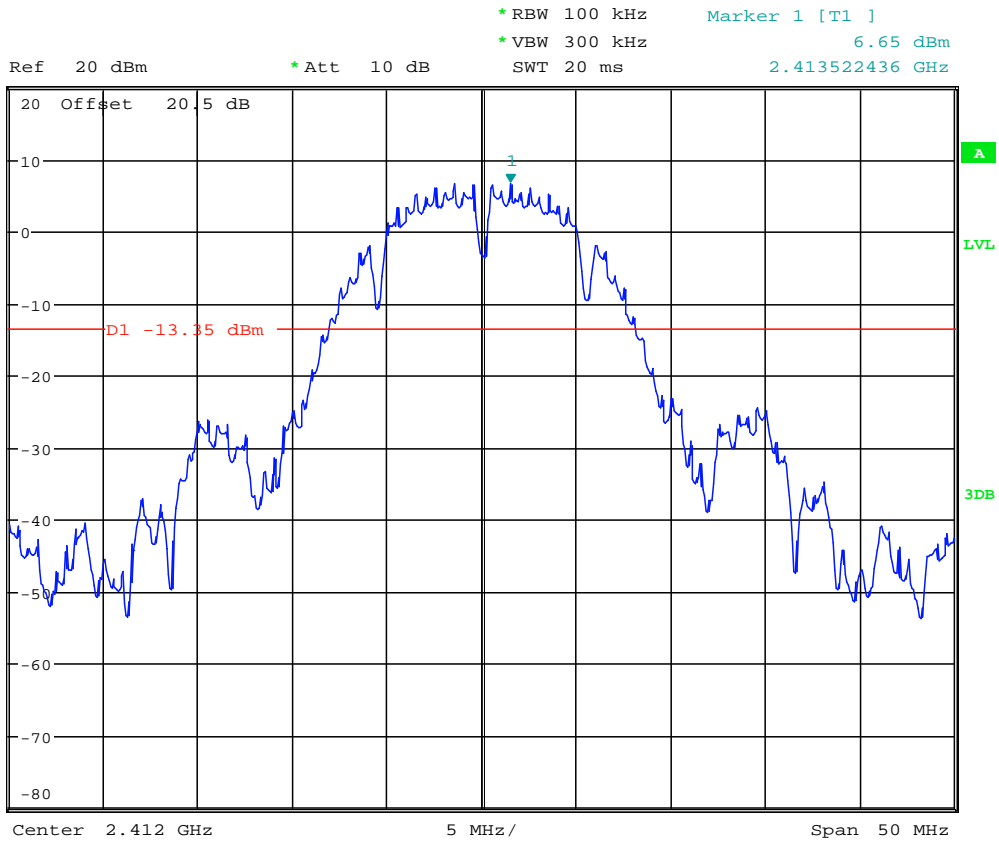

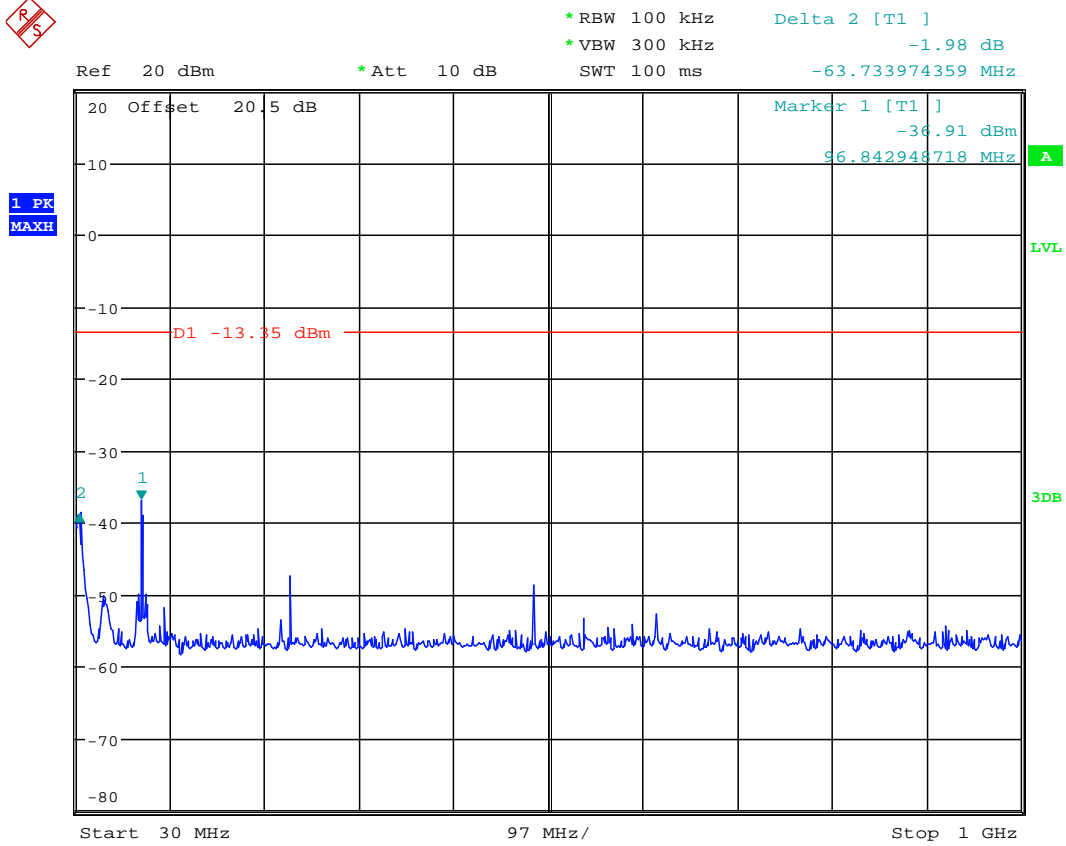
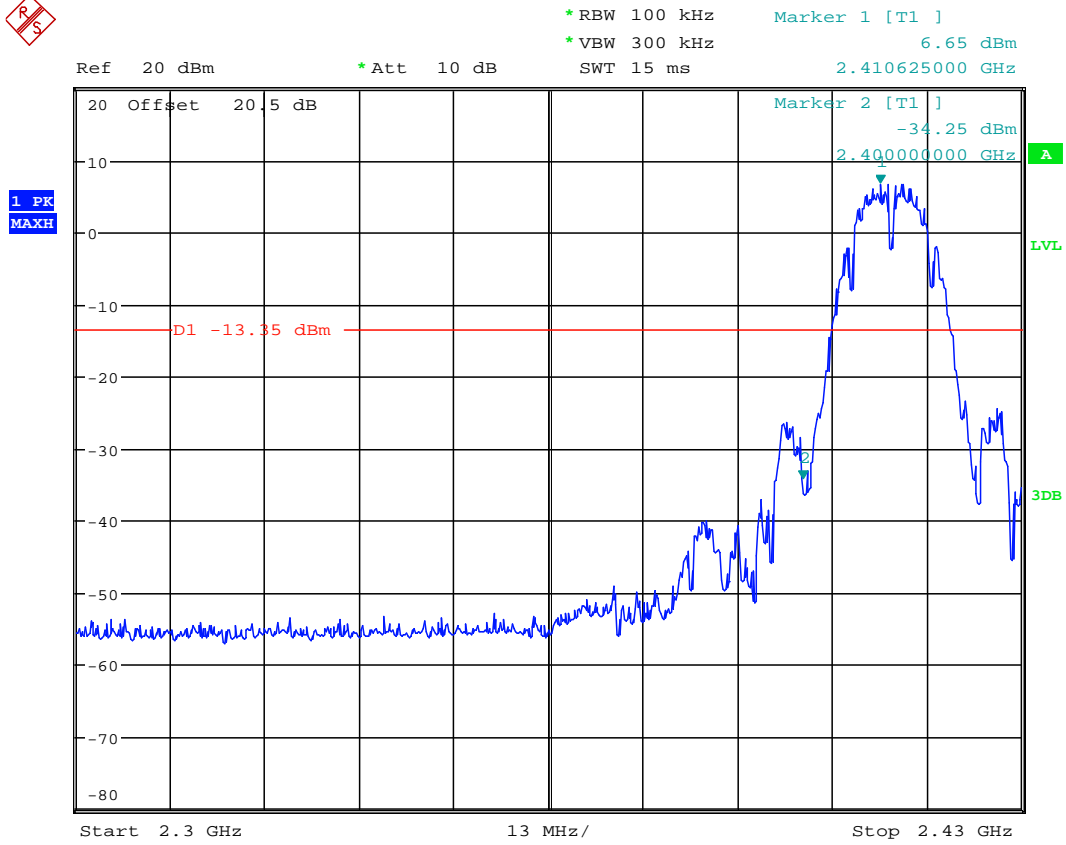

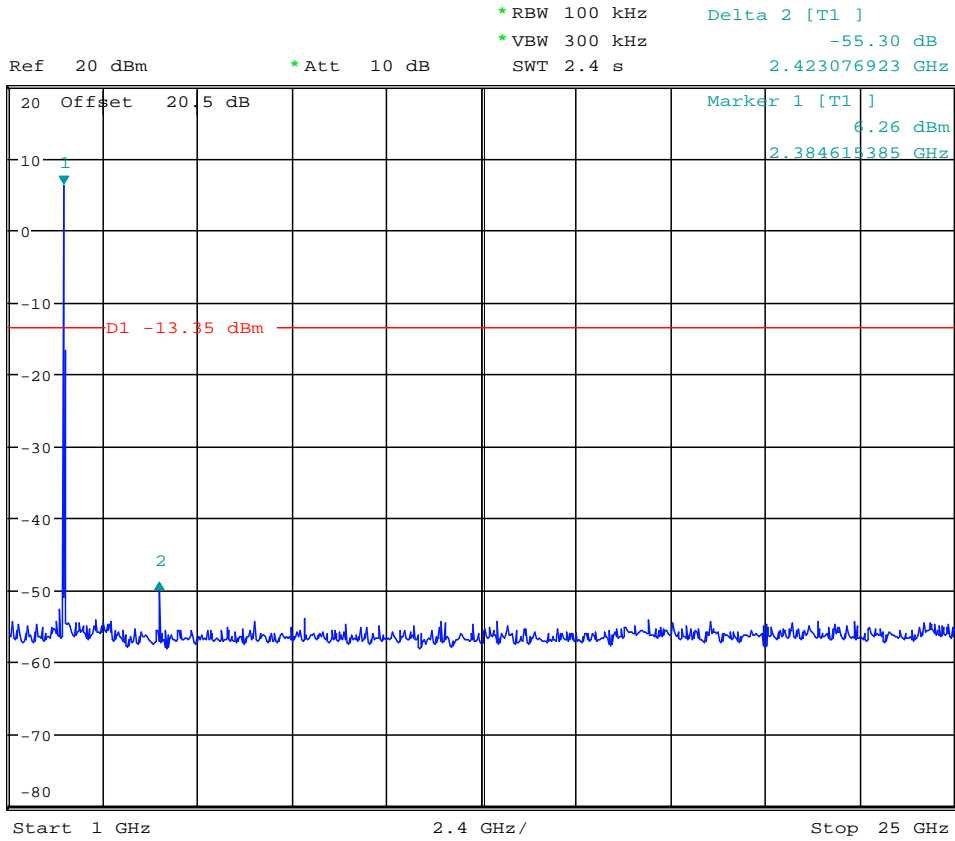

Chain 2 11b CH 6

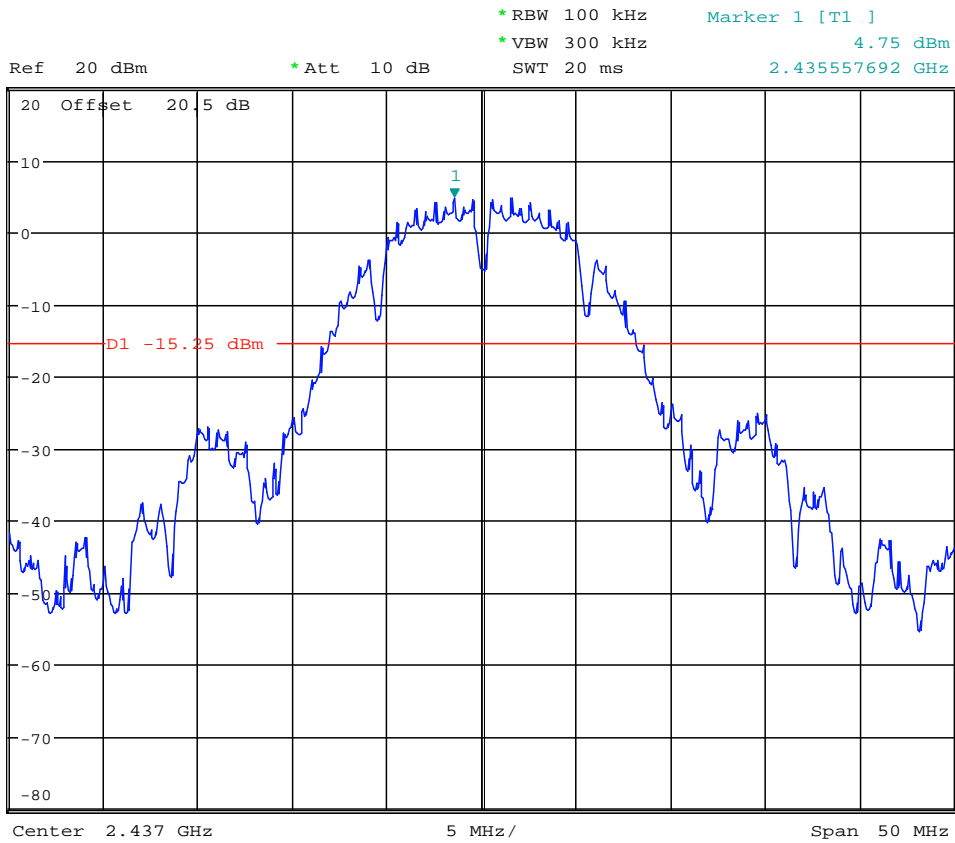

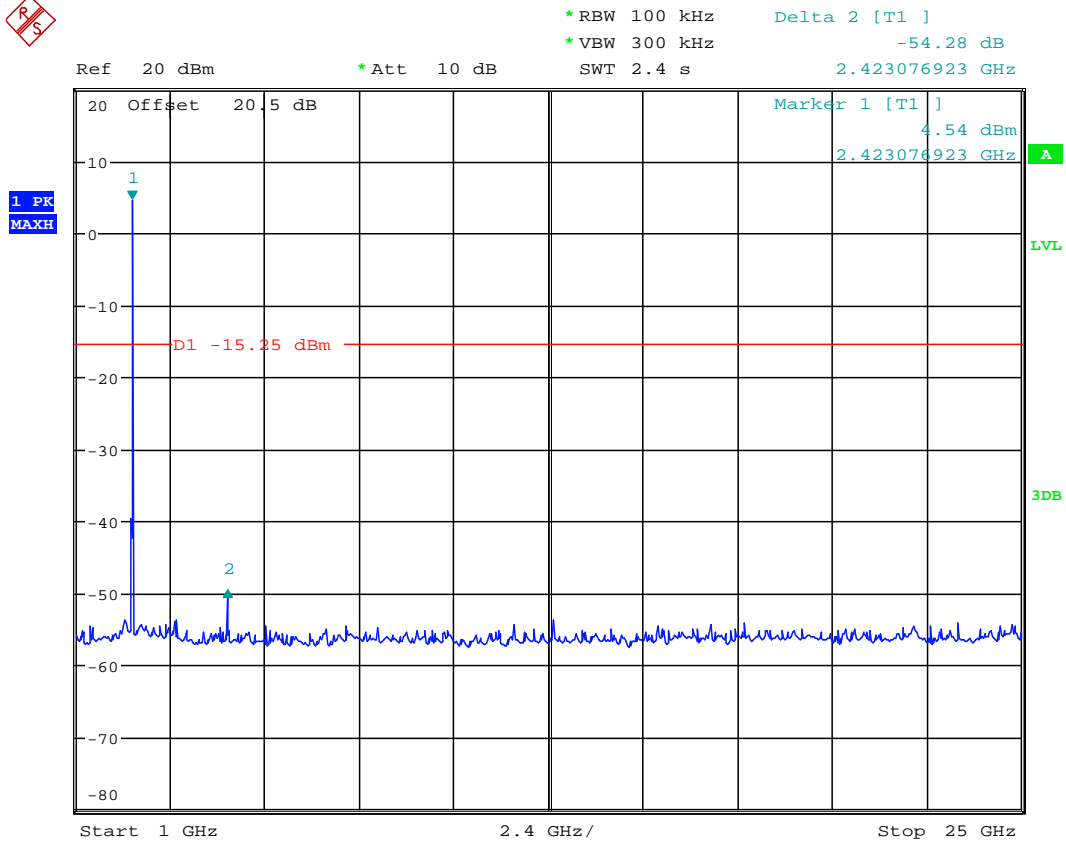
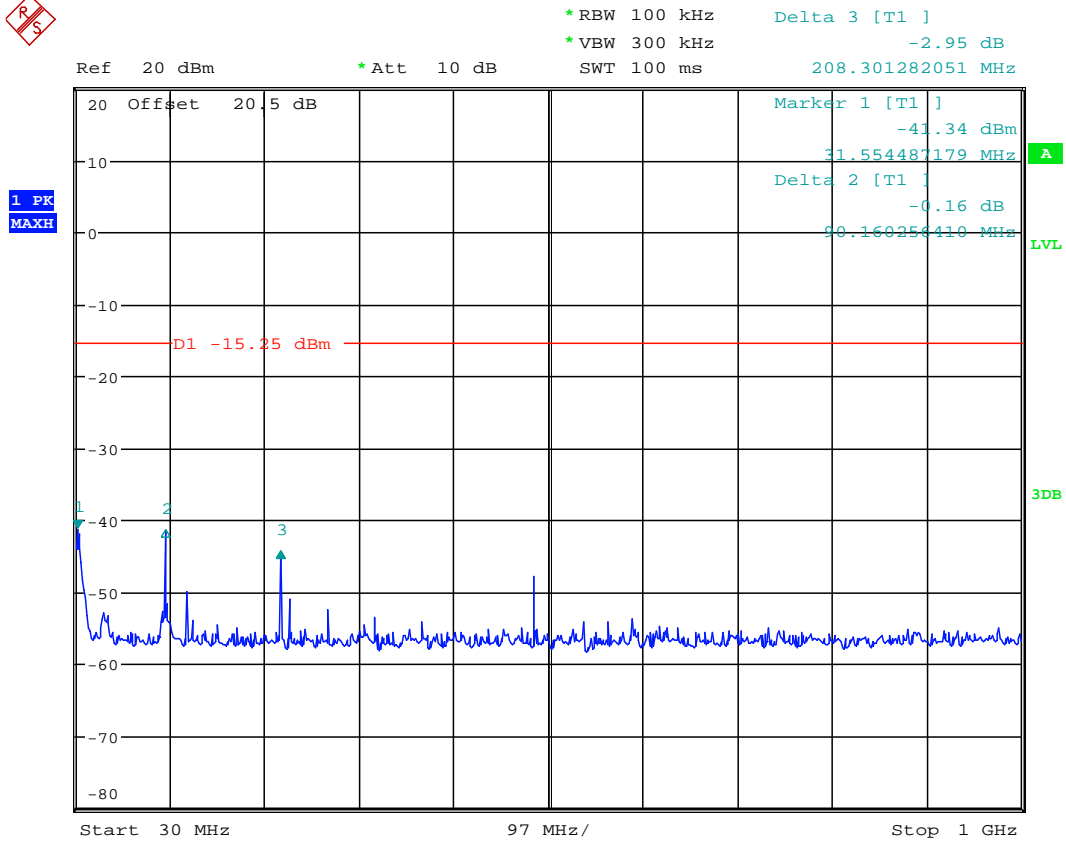

Chain 2 11b CH 11



Ref 20 dBm *Att 10 dB *RBW 100 kHz Marker 1 [T1]
*VBW 300 kHz 4.18 dBm
SWT 20 ms 2.460557692 GHz

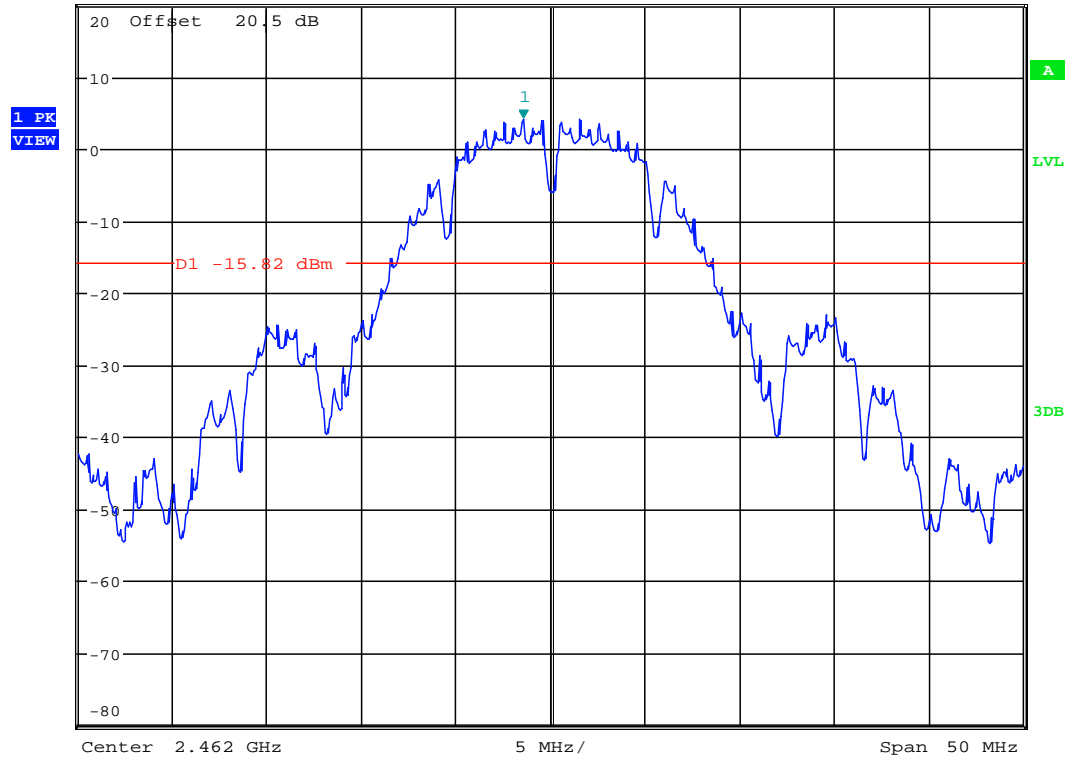

Ref 20 dBm *Att 10 dB *RBW 100 kHz Marker 2 [T1]
*VBW 300 kHz -43.61 dBm
SWT 15 ms 2.483500000 GHz

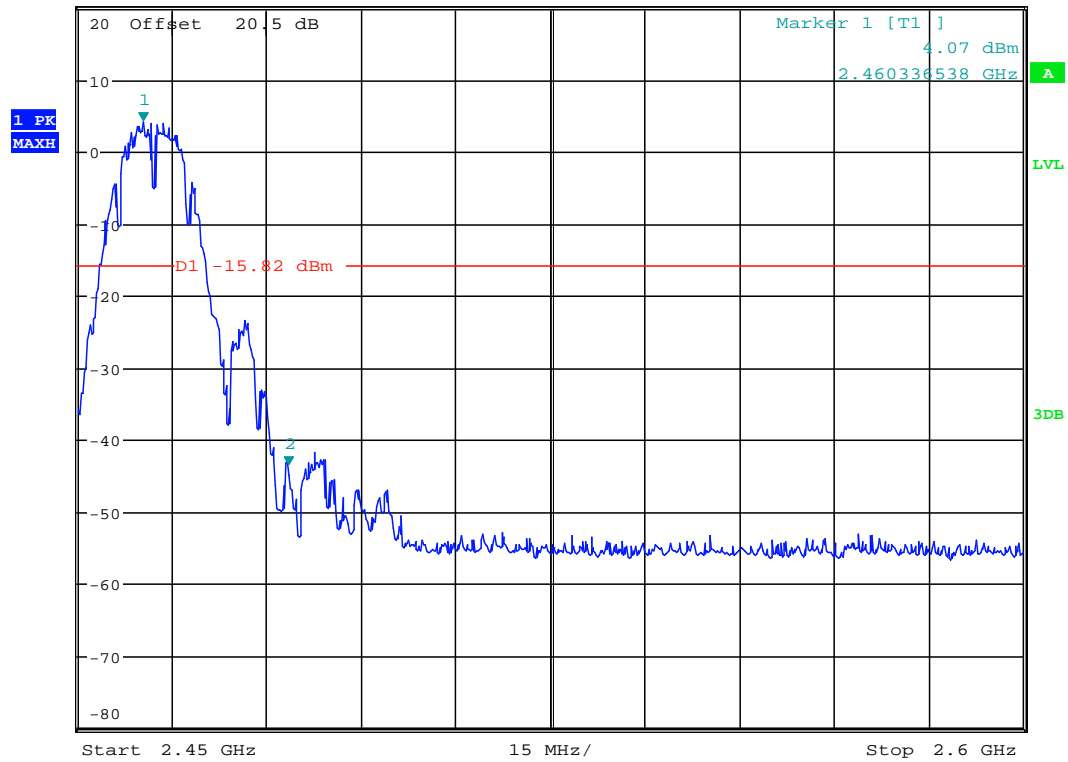

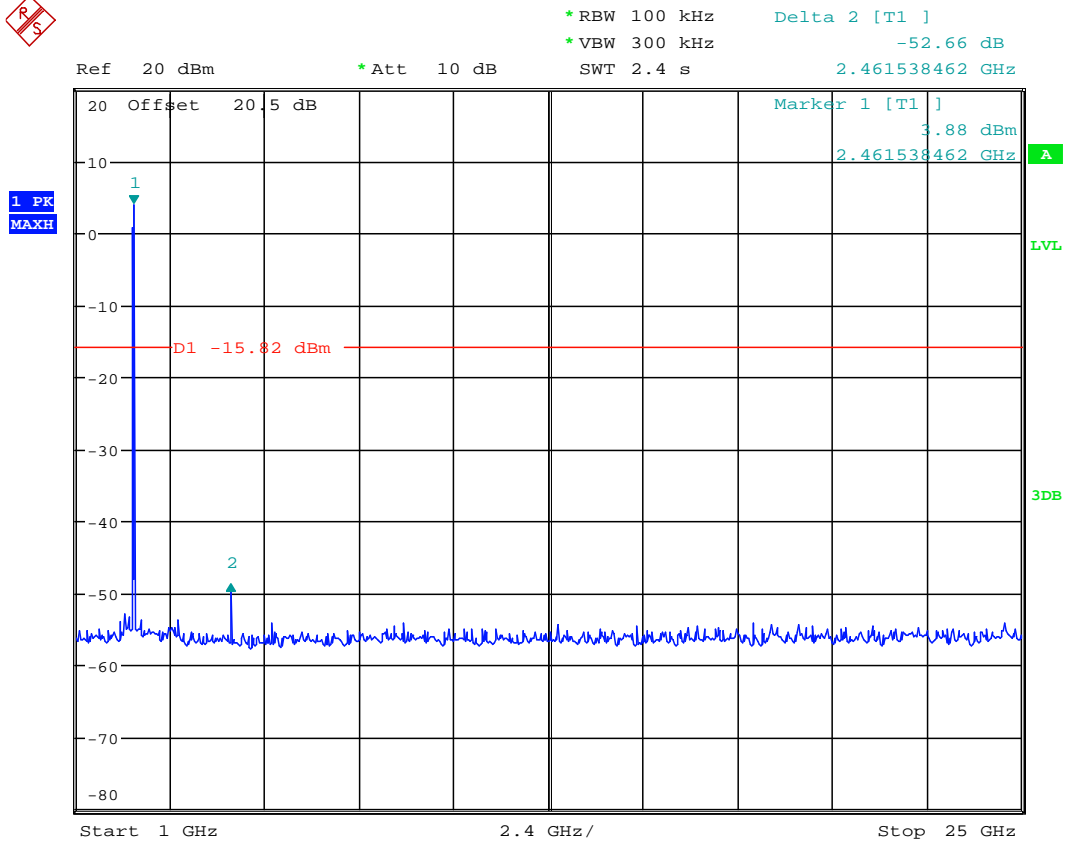
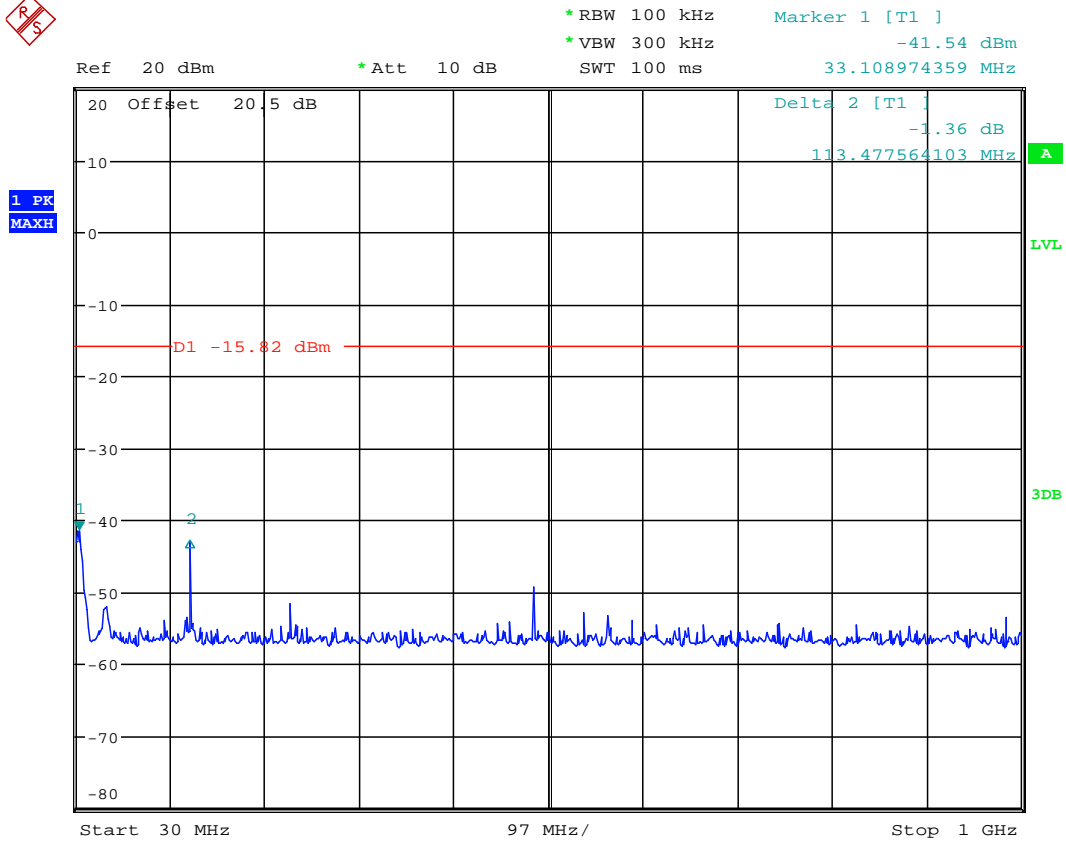

Chain 2 11g CH 1



Ref 20 dBm *Att 10 dB *RBW 100 kHz Marker 1 [T1]
*VBW 300 kHz 3.46 dBm
SWT 20 ms 2.405509615 GHz

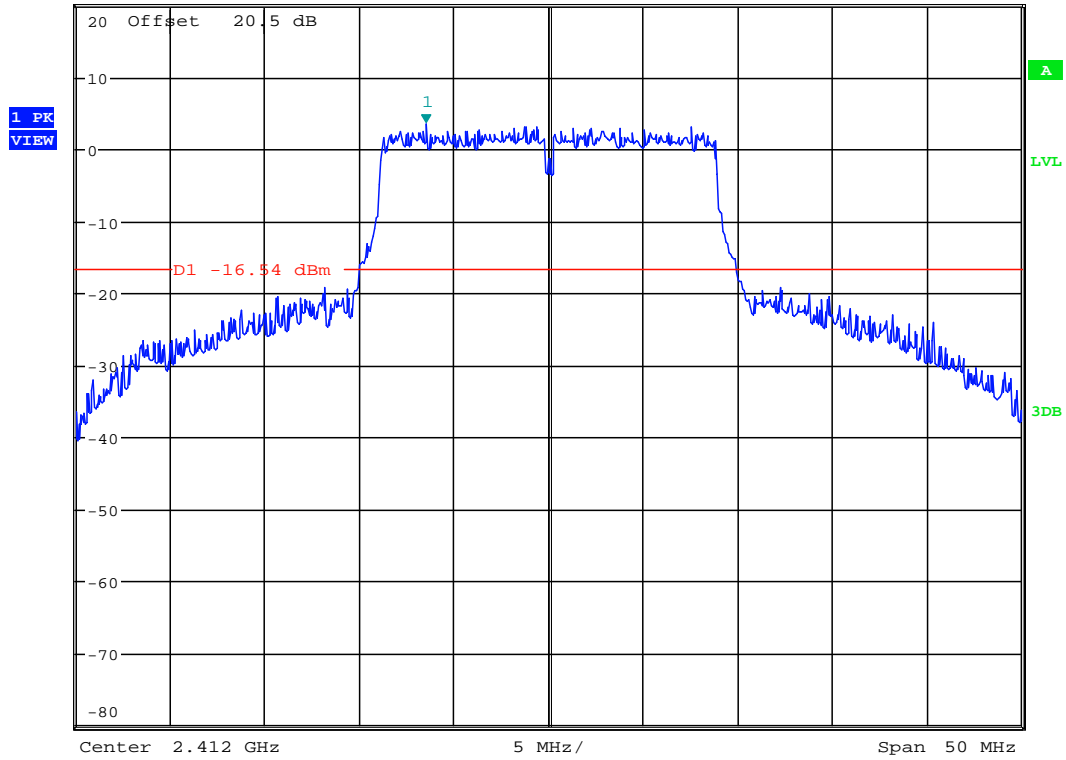

Ref 20 dBm *Att 10 dB *RBW 100 kHz Marker 2 [T1]
*VBW 300 kHz -22.11 dBm
SWT 15 ms 2.400000000 GHz

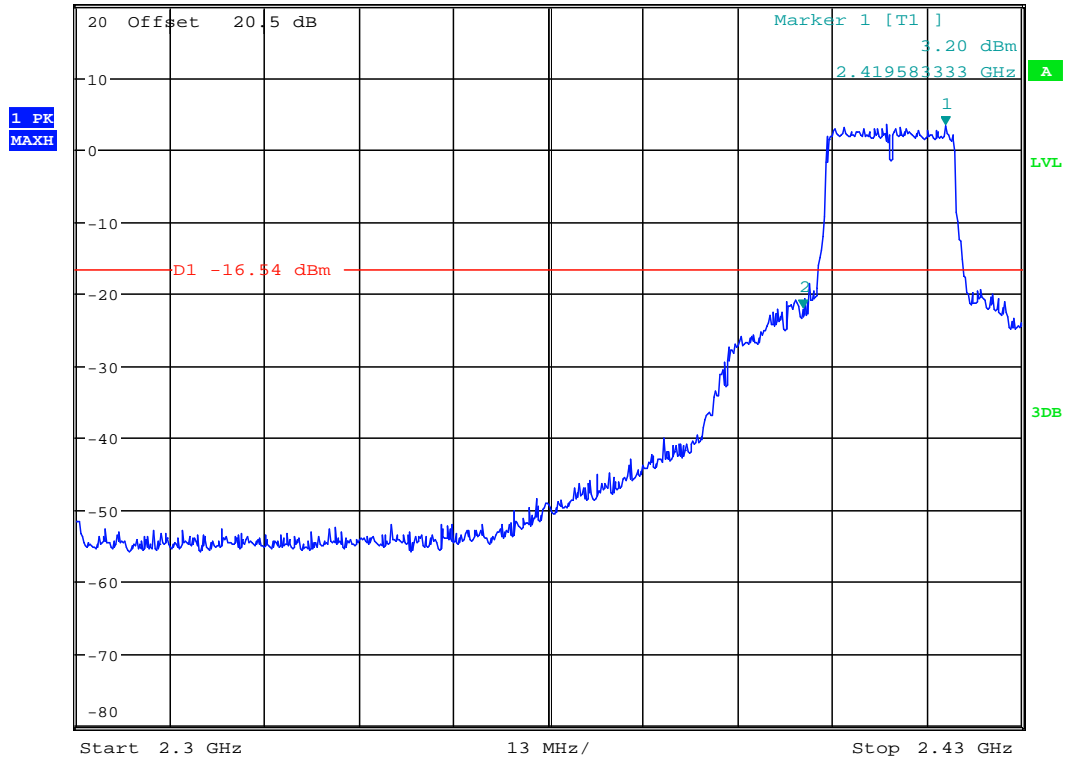

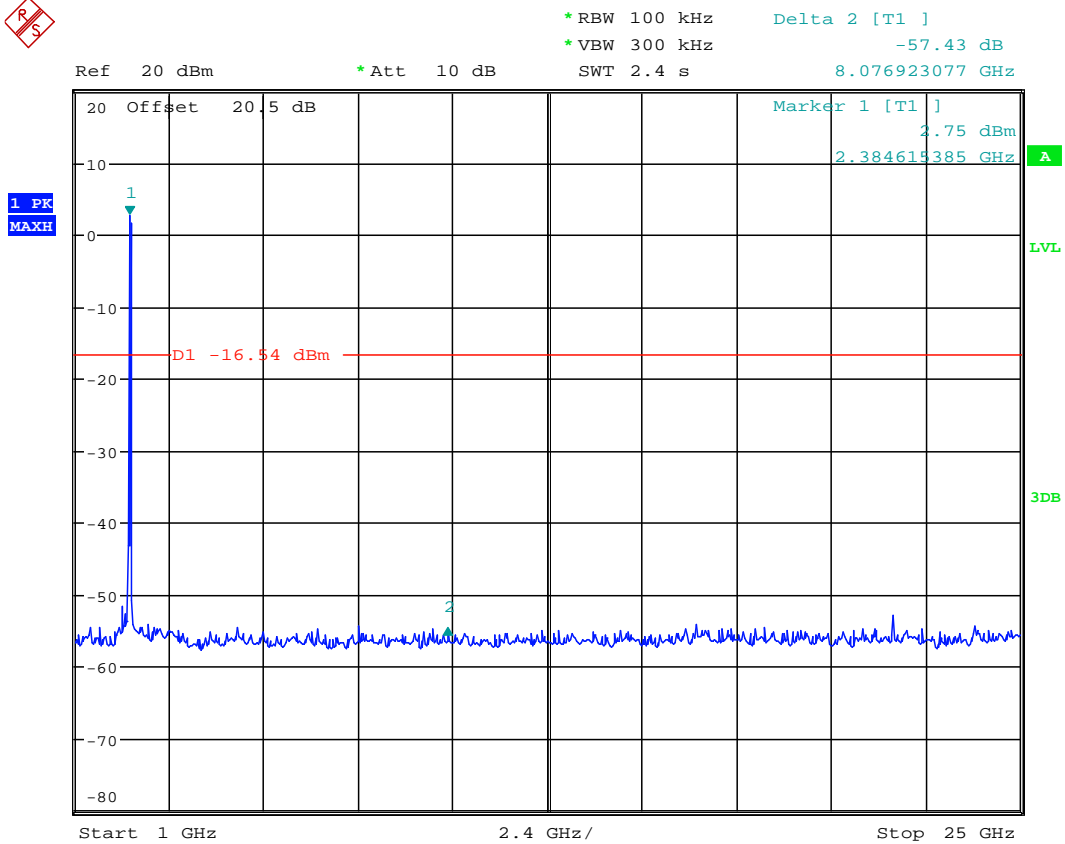
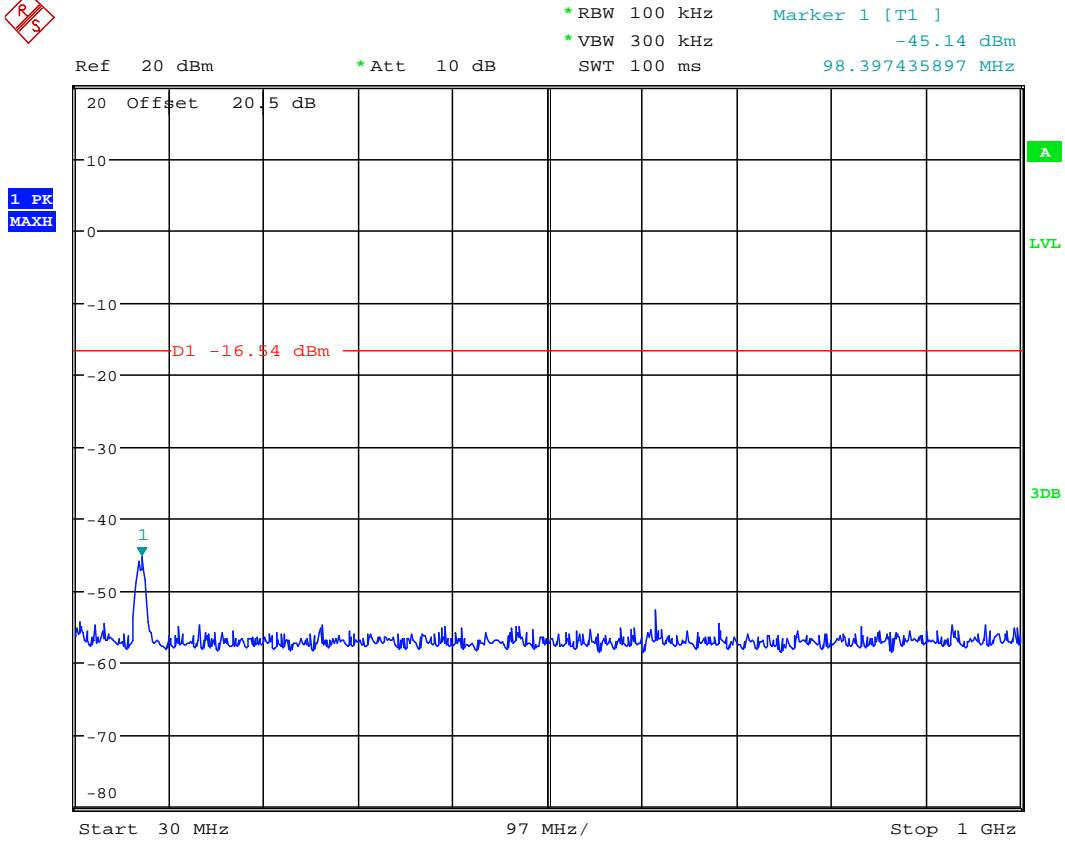

Chain 2 11g CH 6



Ref 20 dBm *Att 10 dB *RBW 100 kHz Marker 1 [T1]
*VBW 300 kHz 2.92 dBm
SWT 20 ms 2.435798077 GHz

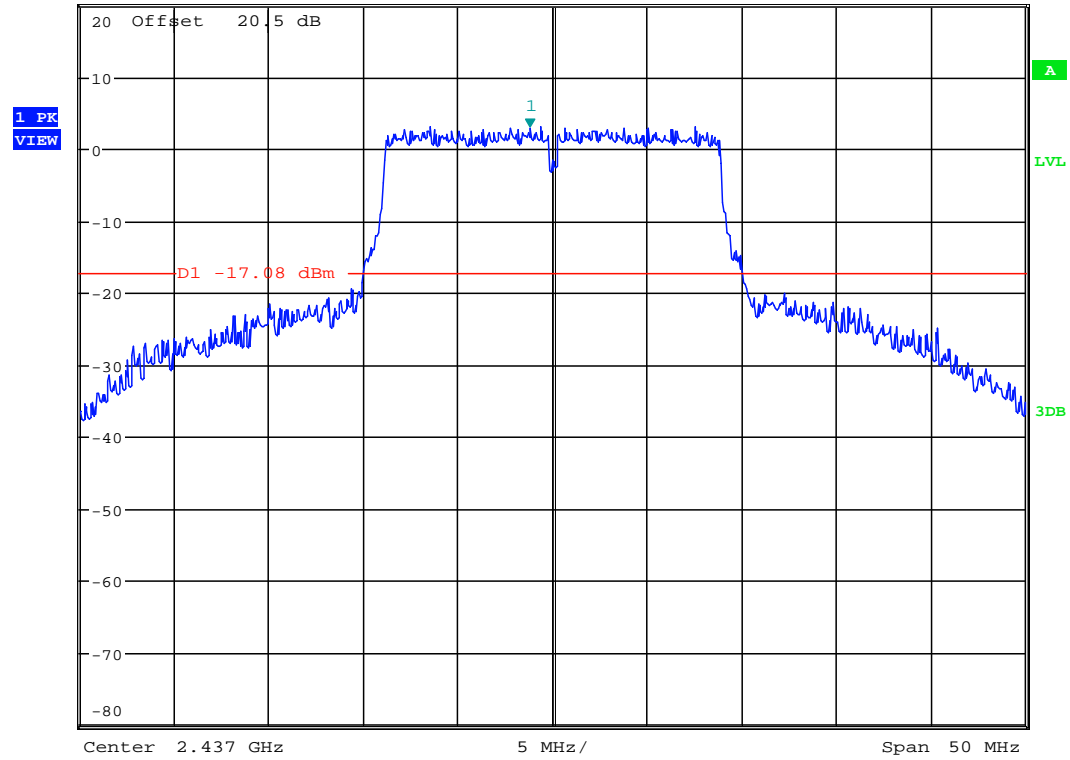

Ref 20 dBm *Att 10 dB *RBW 100 kHz Marker 1 [T1]
*VBW 300 kHz -47.40 dBm
SWT 100 ms 123.269230769 MHz

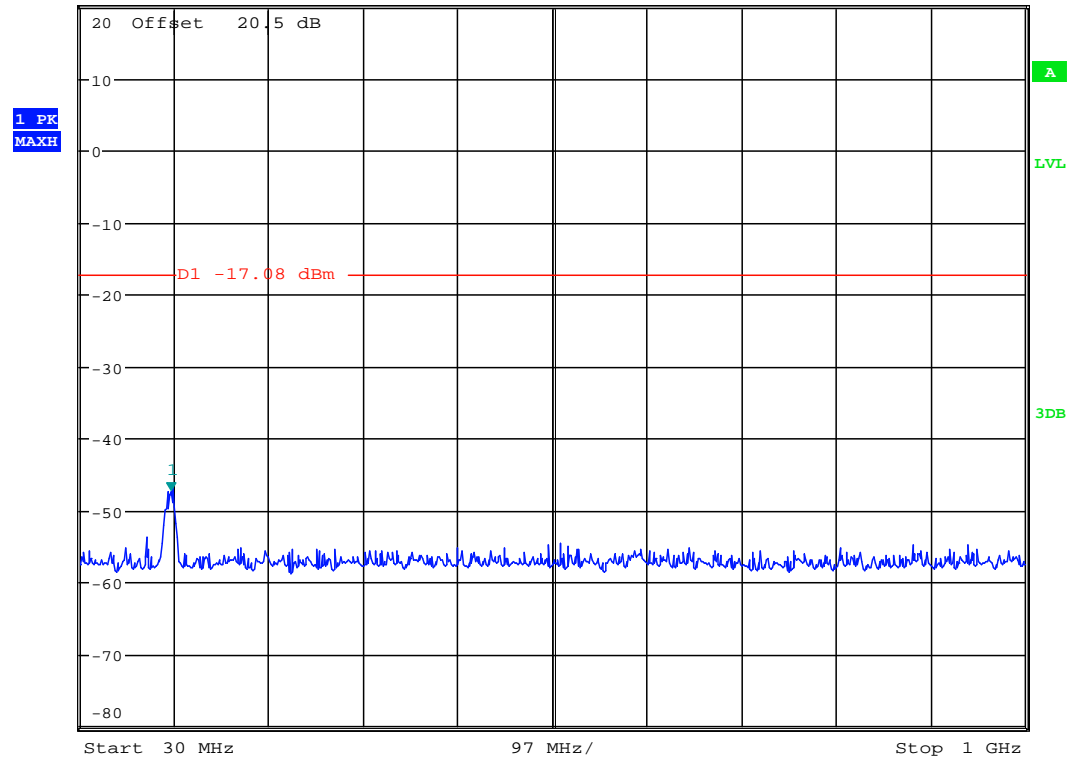

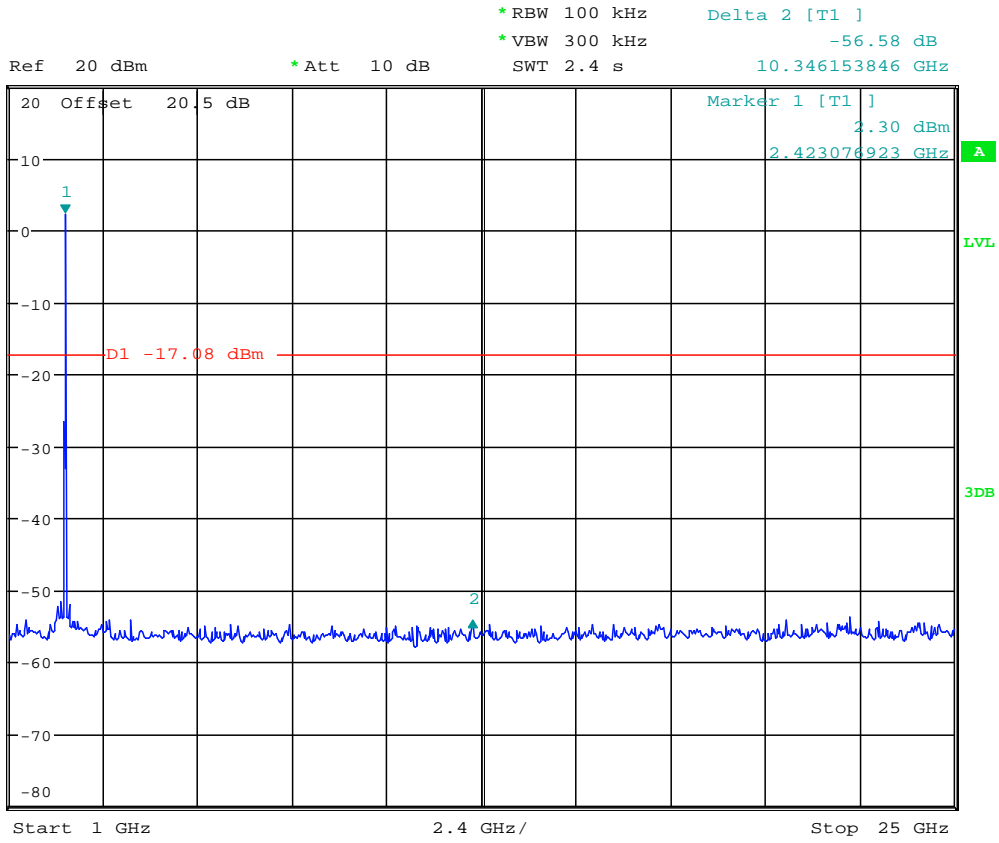

Chain 2 11g CH 11

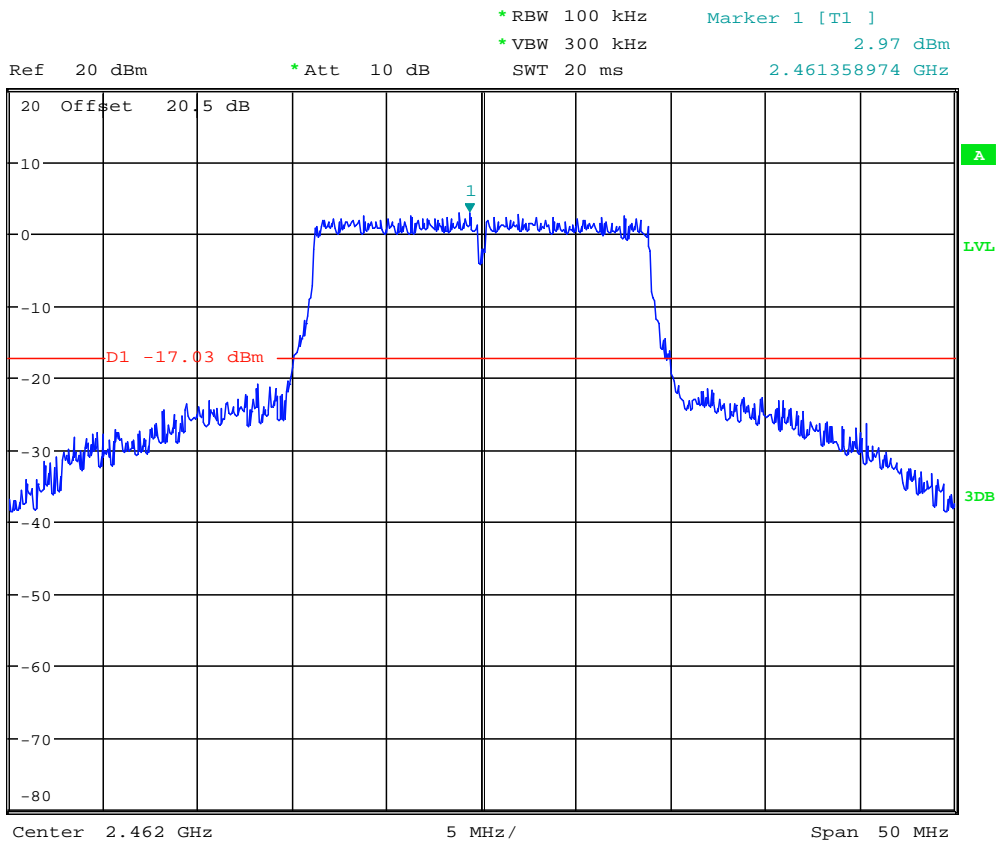



Ref 20 dBm *Att 10 dB *RBW 100 kHz Marker 2 [T1]
-31.25 dBm
*VBW 300 kHz
SWT 15 ms 2.483500000 GHz

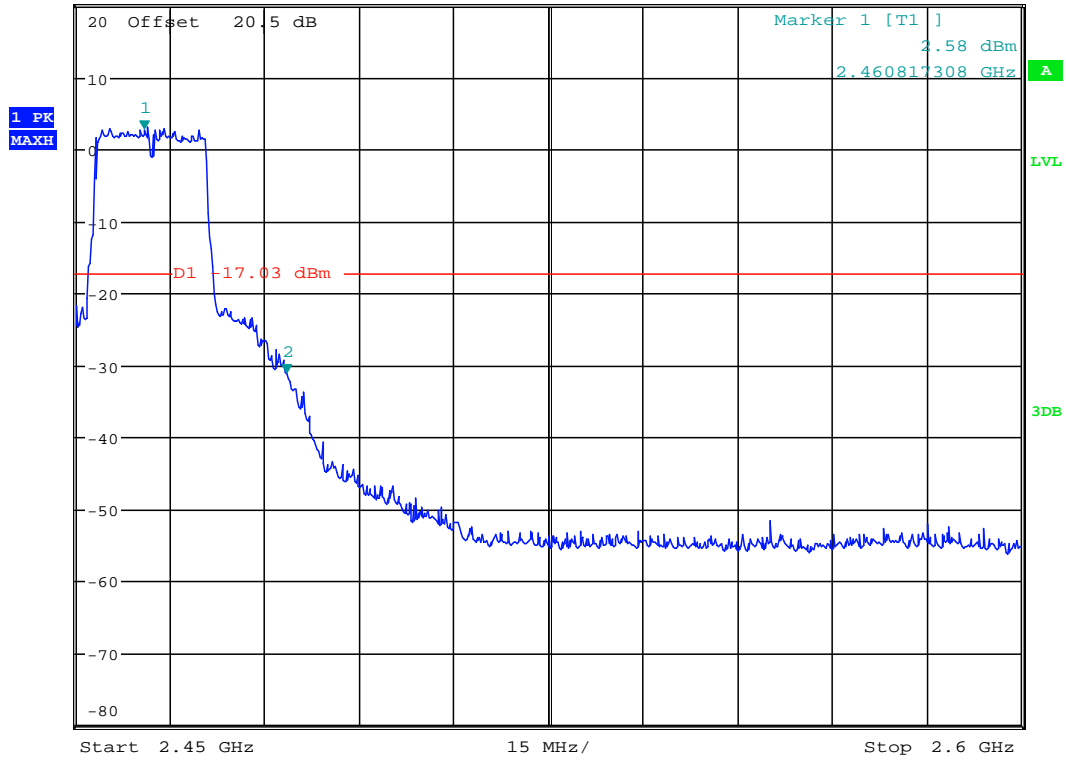

Ref 20 dBm *Att 10 dB *RBW 100 kHz Marker 1 [T1]
-46.55 dBm
*VBW 300 kHz
SWT 100 ms 145.032051282 MHz

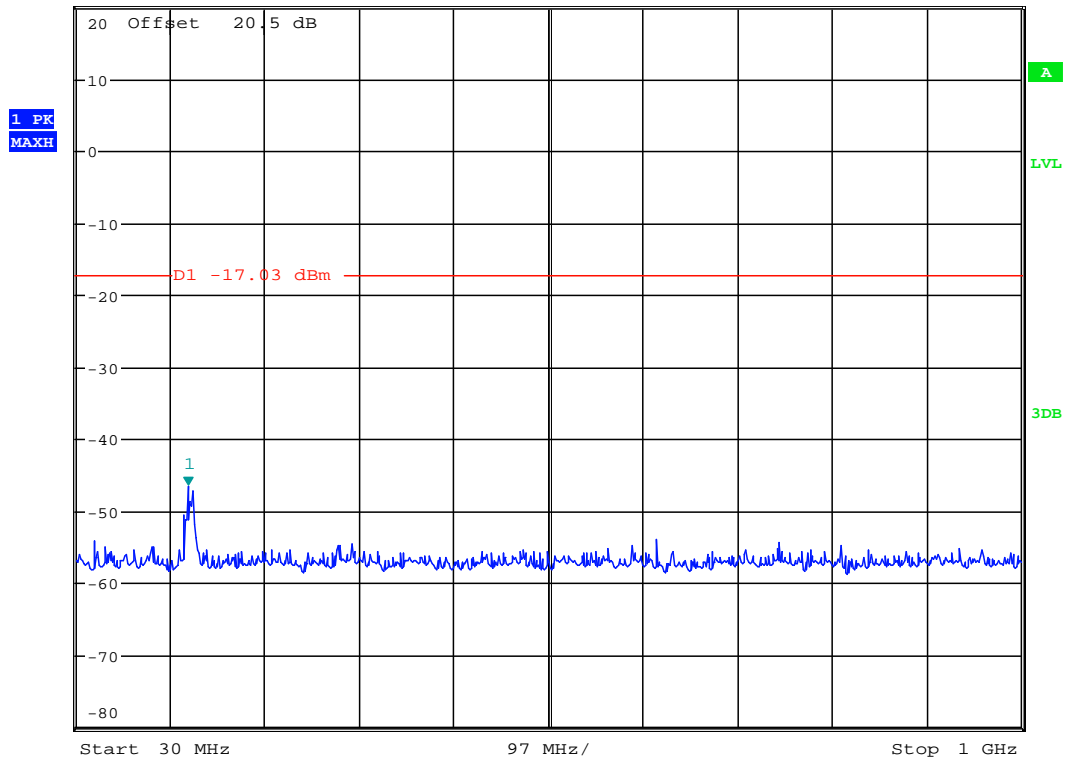

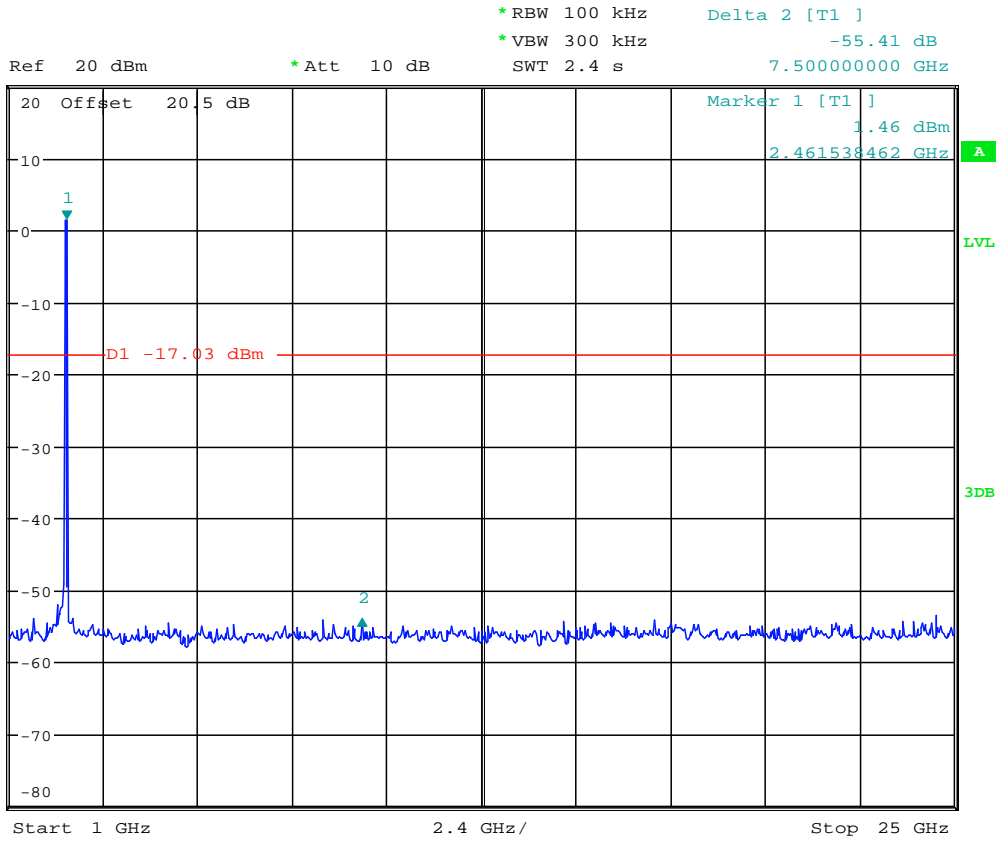

Chain 2 11n HT20 CH 1

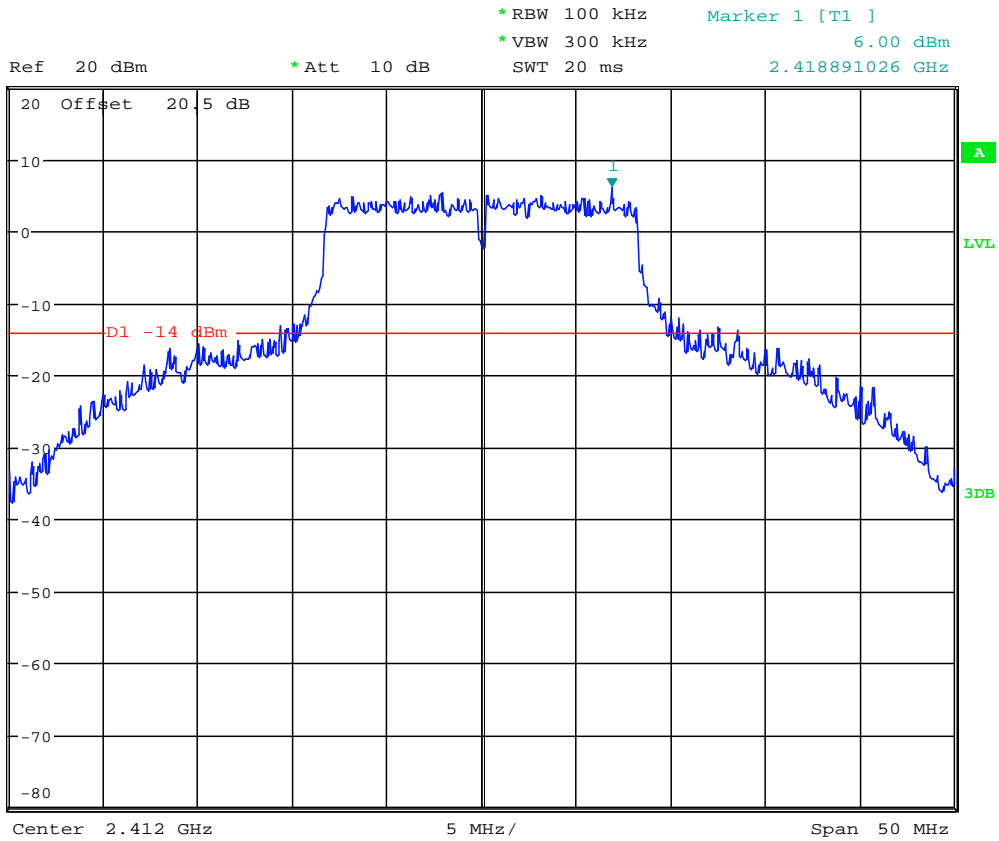

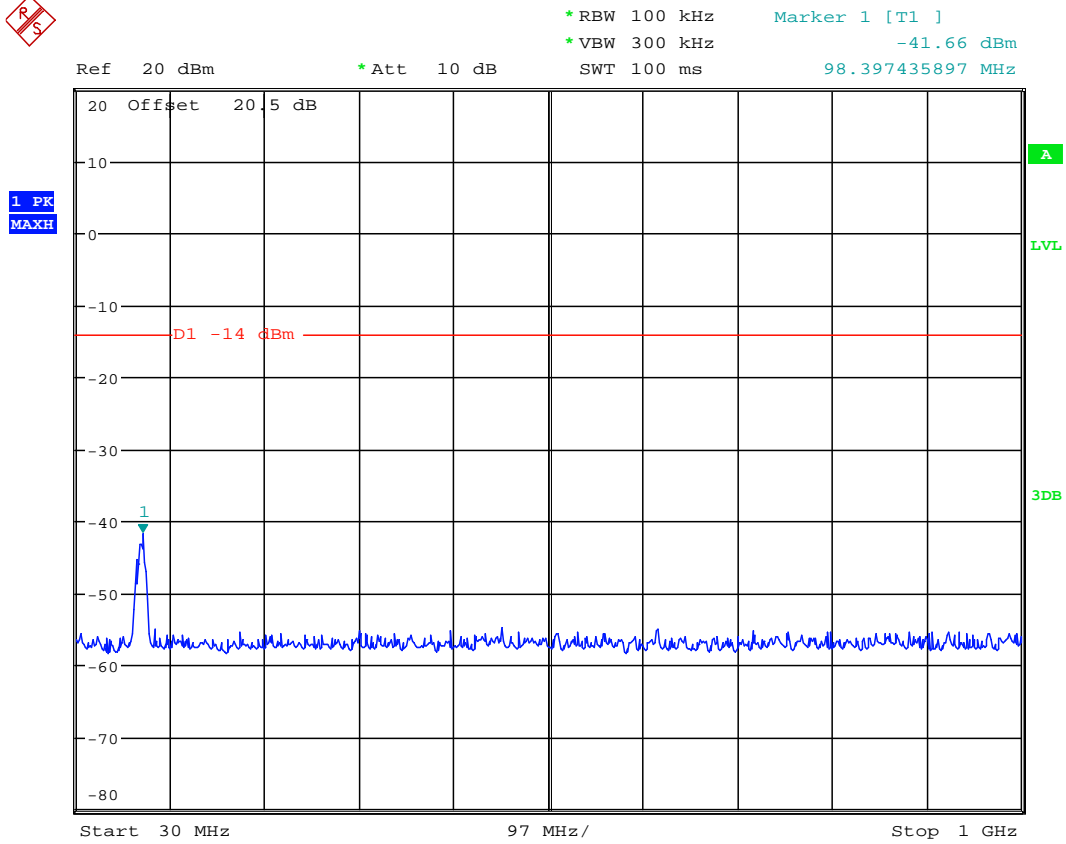
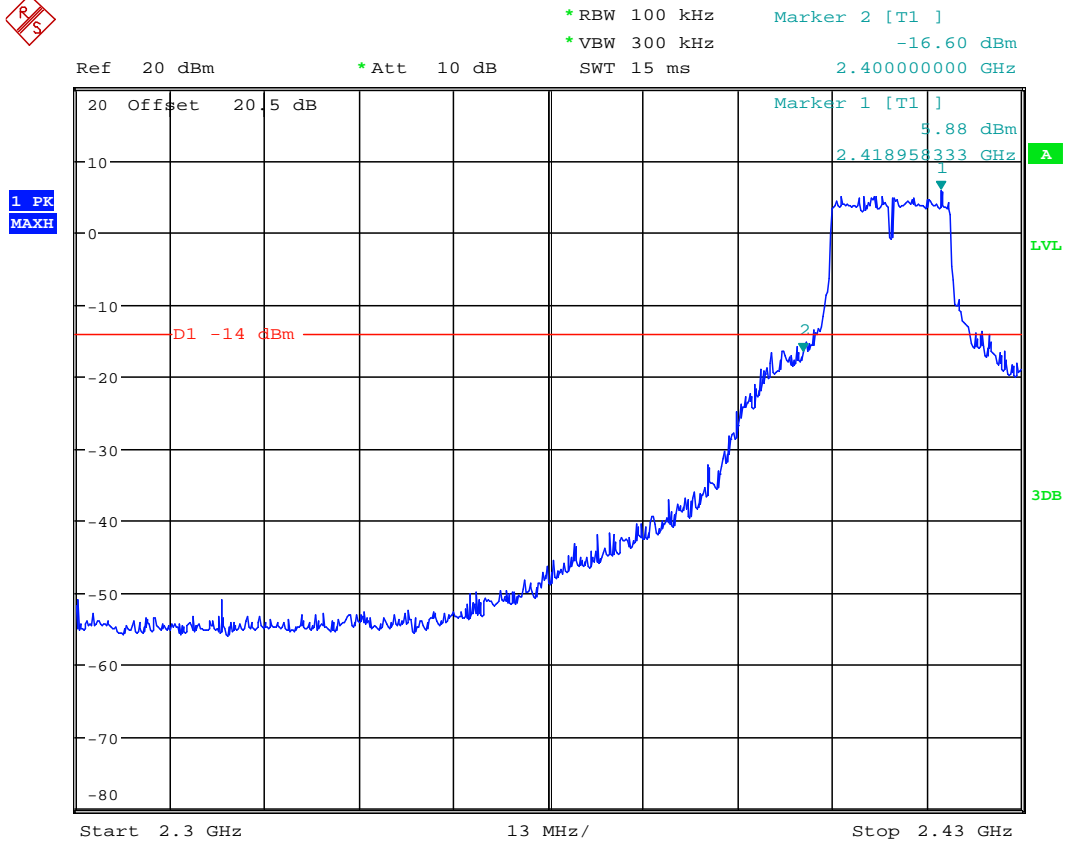



Ref 20 dBm *Att 10 dB *RBW 100 kHz Delta 2 [T1]
*VBW 300 kHz -58.53 dB
SWT 2.4 s 5.500000000 GHz

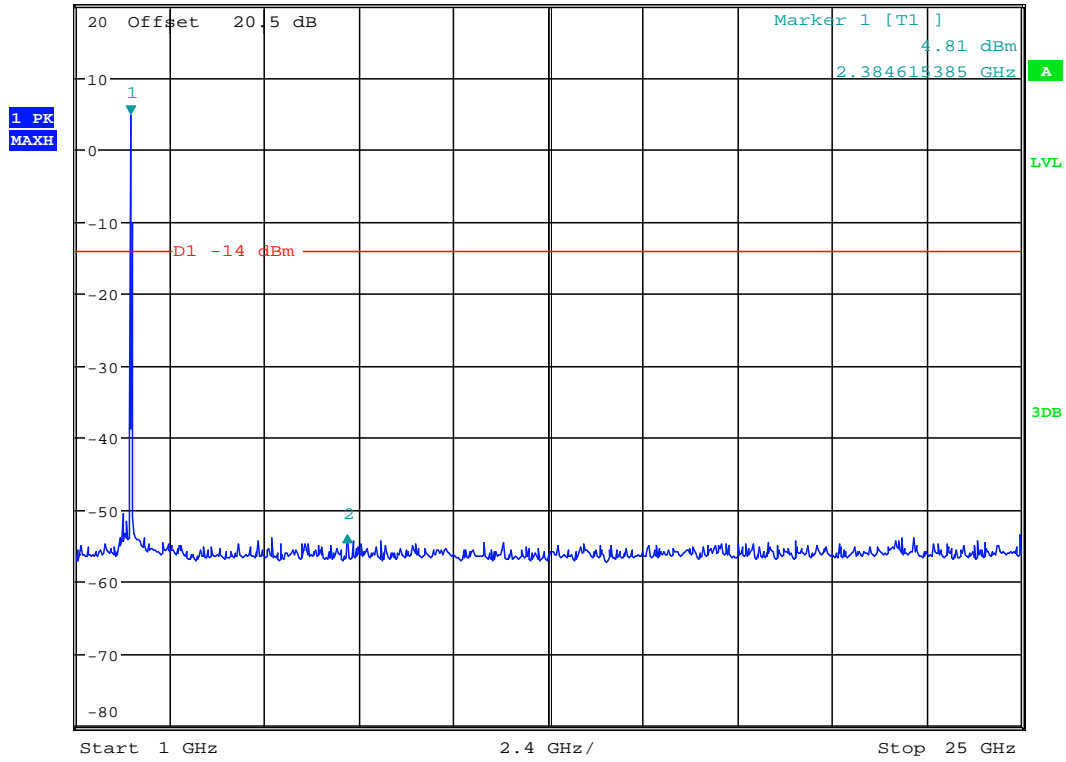

Chain 2 11n HT20 CH 6



Ref 20 dBm *Att 10 dB *RBW 100 kHz Marker 1 [T1]
*VBW 300 kHz 5.02 dBm
SWT 20 ms 2.443971154 GHz

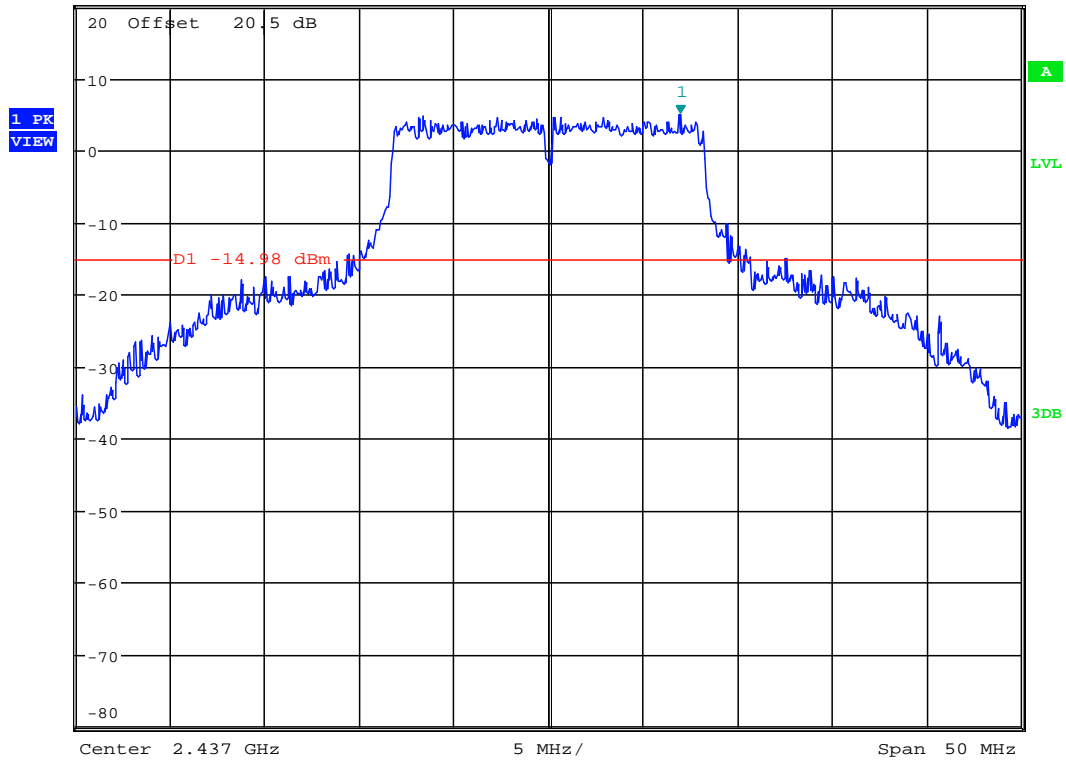

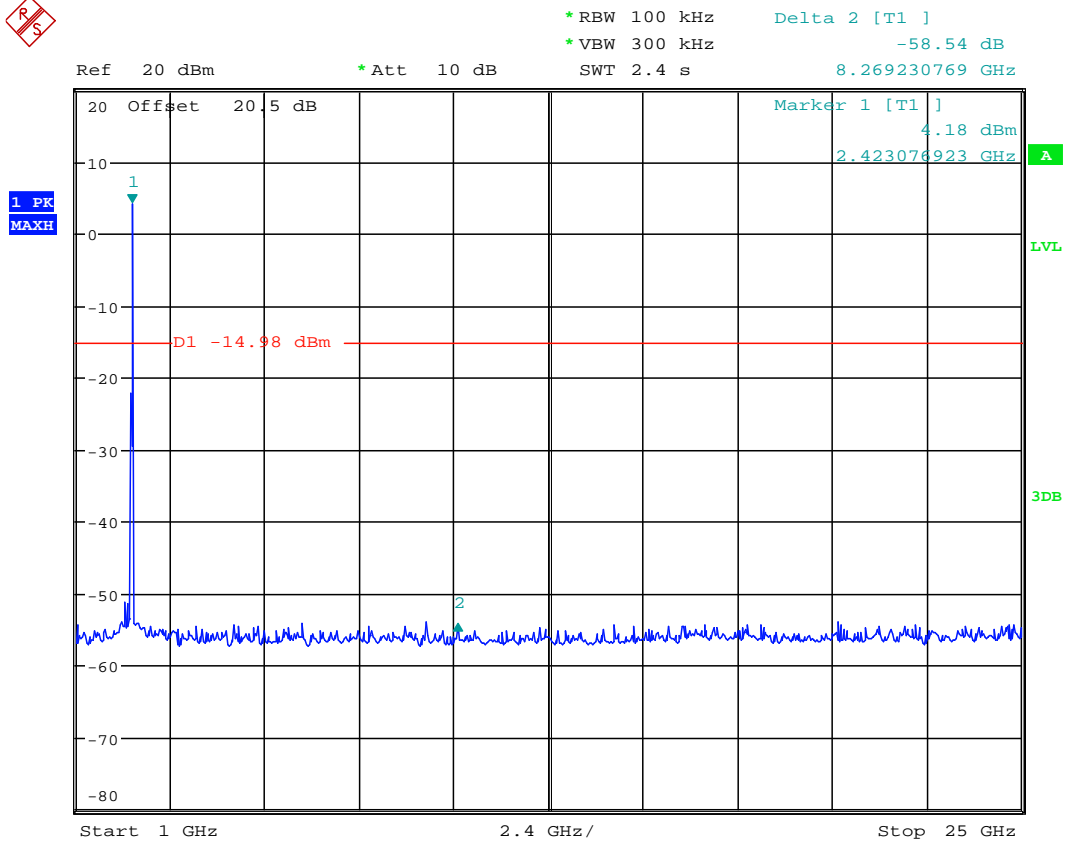
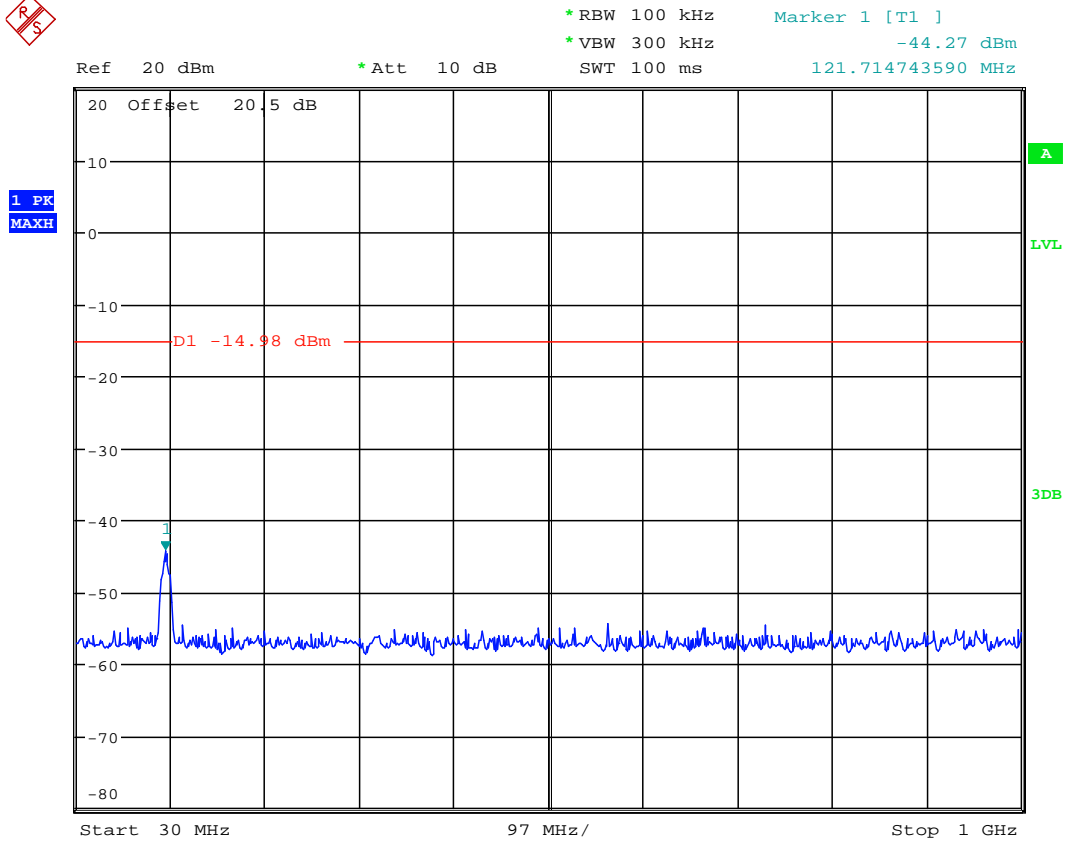

Chain 2 11n HT20 CH 11

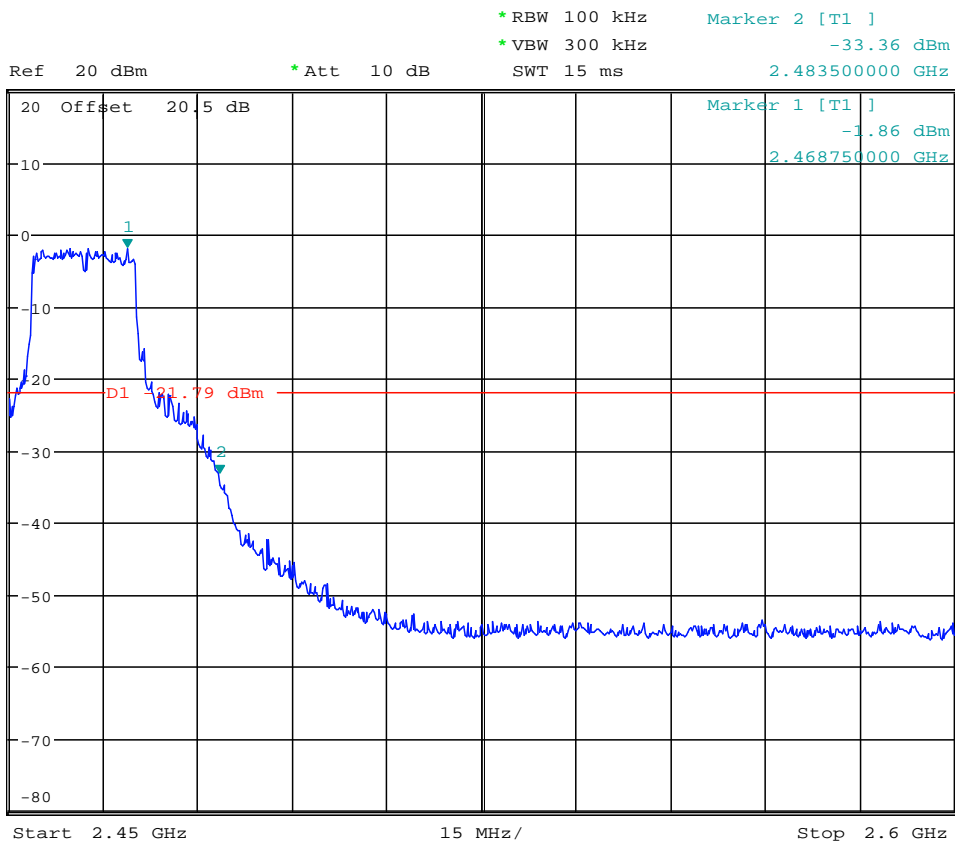
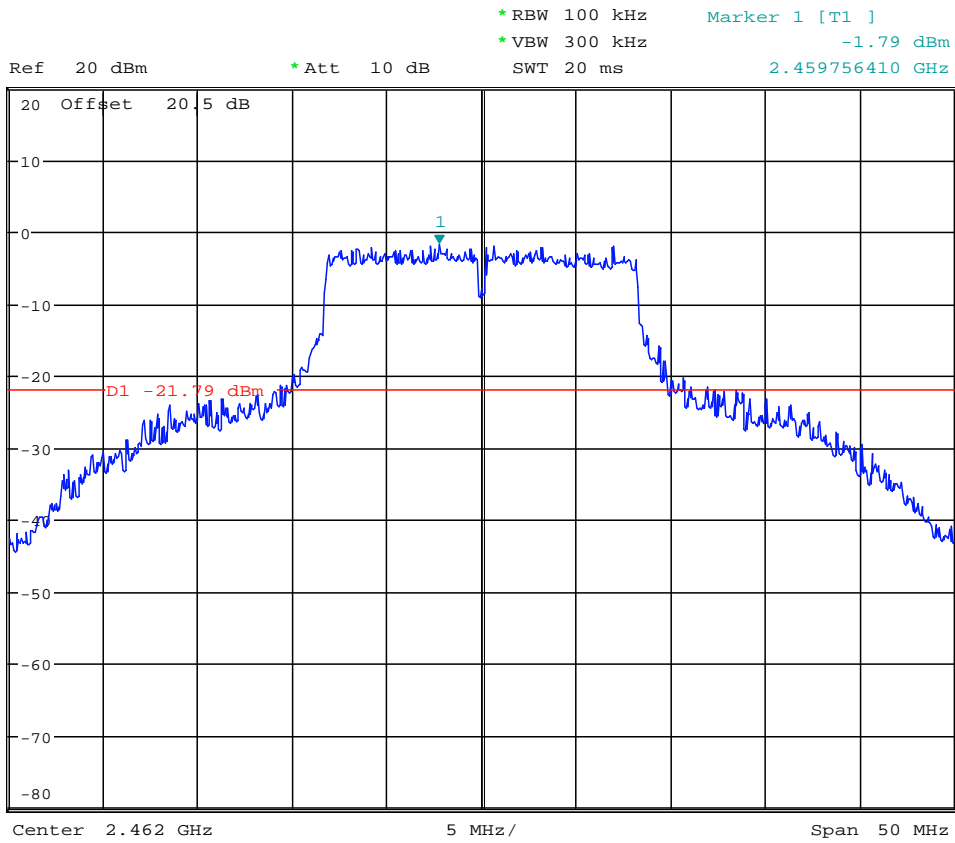



Ref 20 dBm *Att 10 dB *RBW 100 kHz Marker 1 [T1]
*VBW 300 kHz -45.03 dBm
SWT 100 ms 33.108974359 MHz

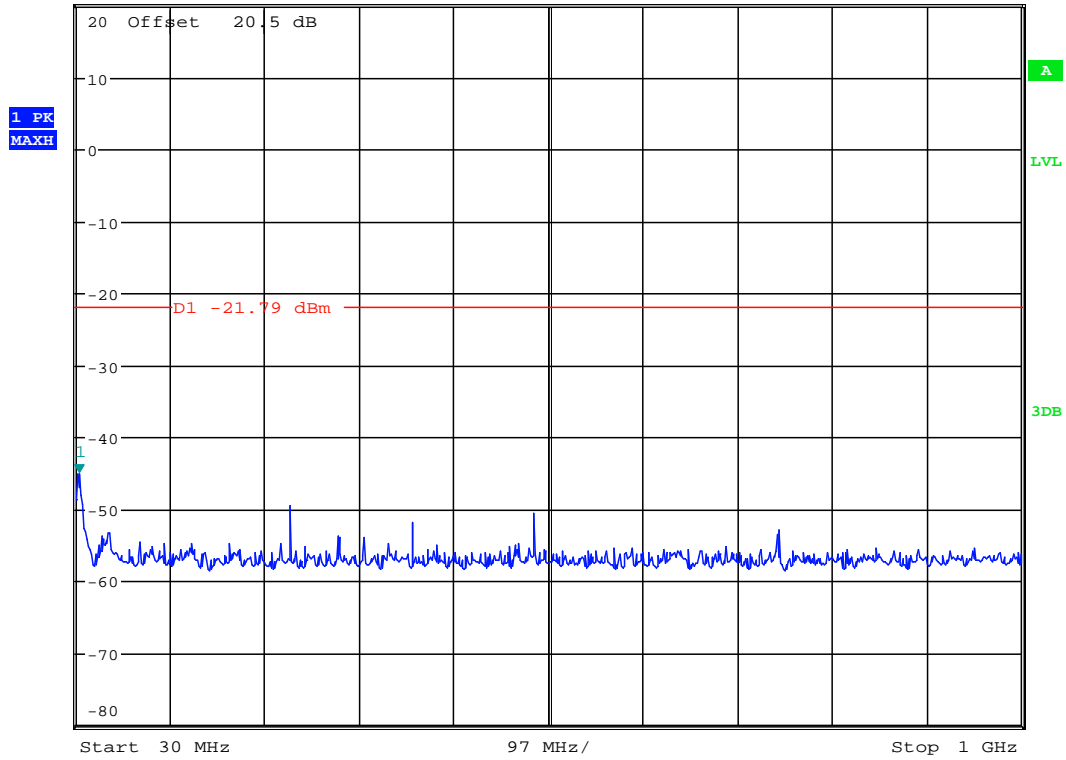

Ref 20 dBm *Att 10 dB *RBW 100 kHz Delta 2 [T1]
*VBW 300 kHz -51.73 dB
SWT 2.4 s 16.846153846 GHz

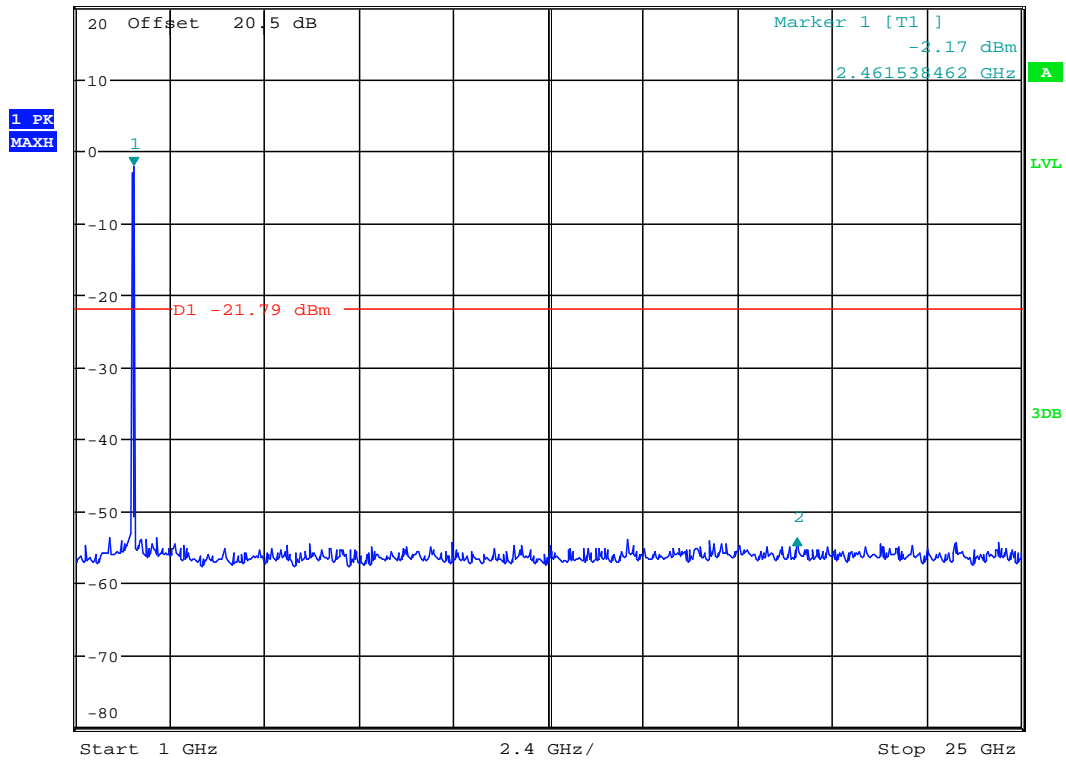

Chain 2 11n HT40 CH 3

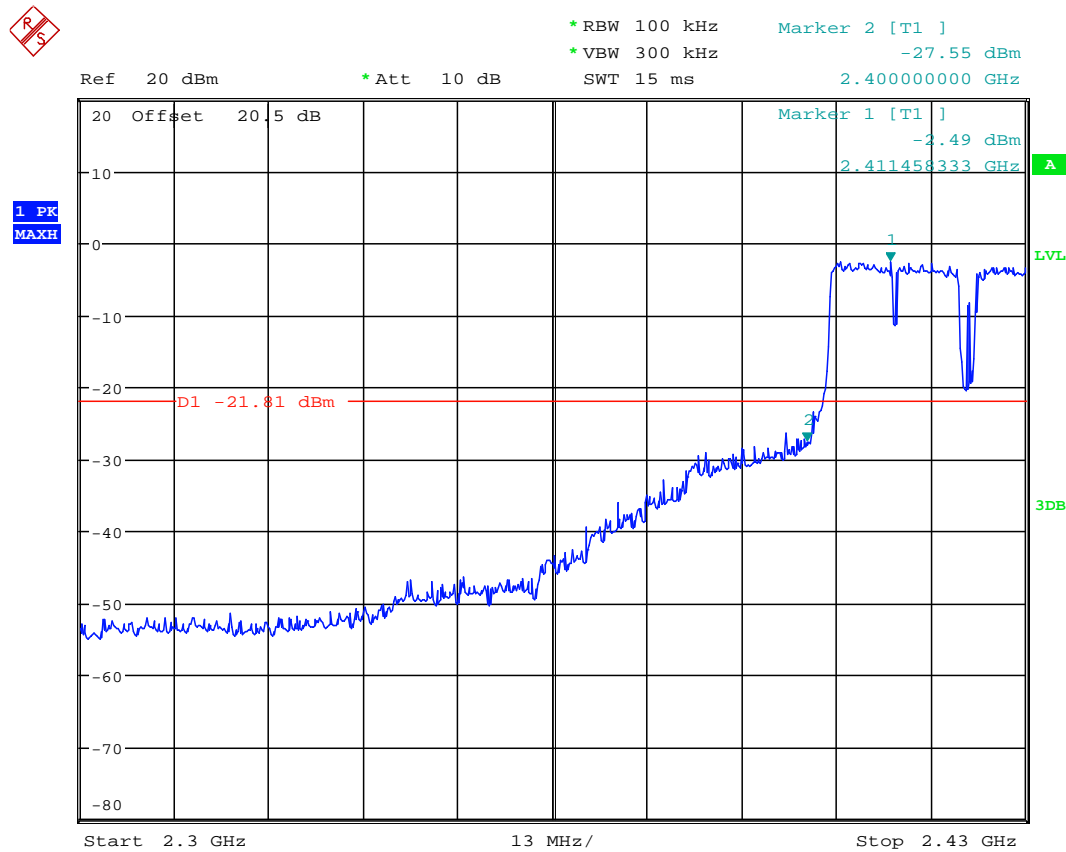
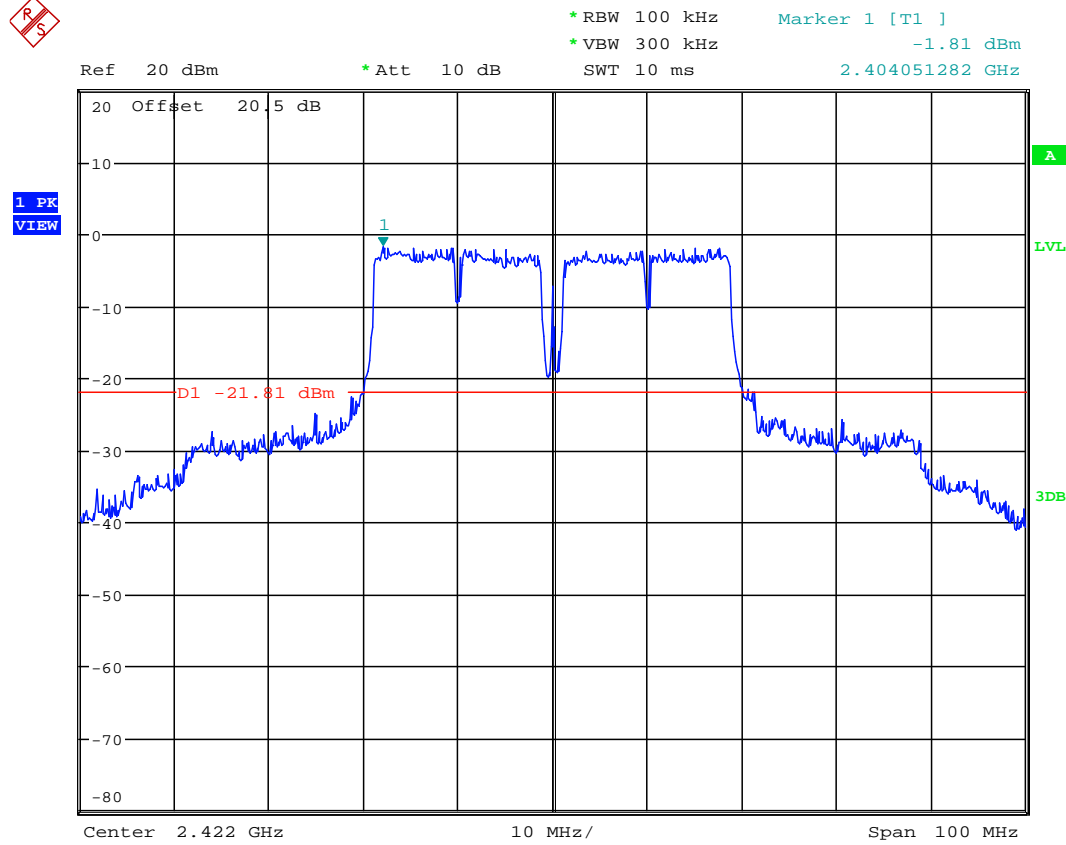



Ref 20 dBm *Att 10 dB *RBW 100 kHz Marker 1 [T1]
*VBW 300 kHz -51.39 dBm
SWT 100 ms 107.724358974 MHz

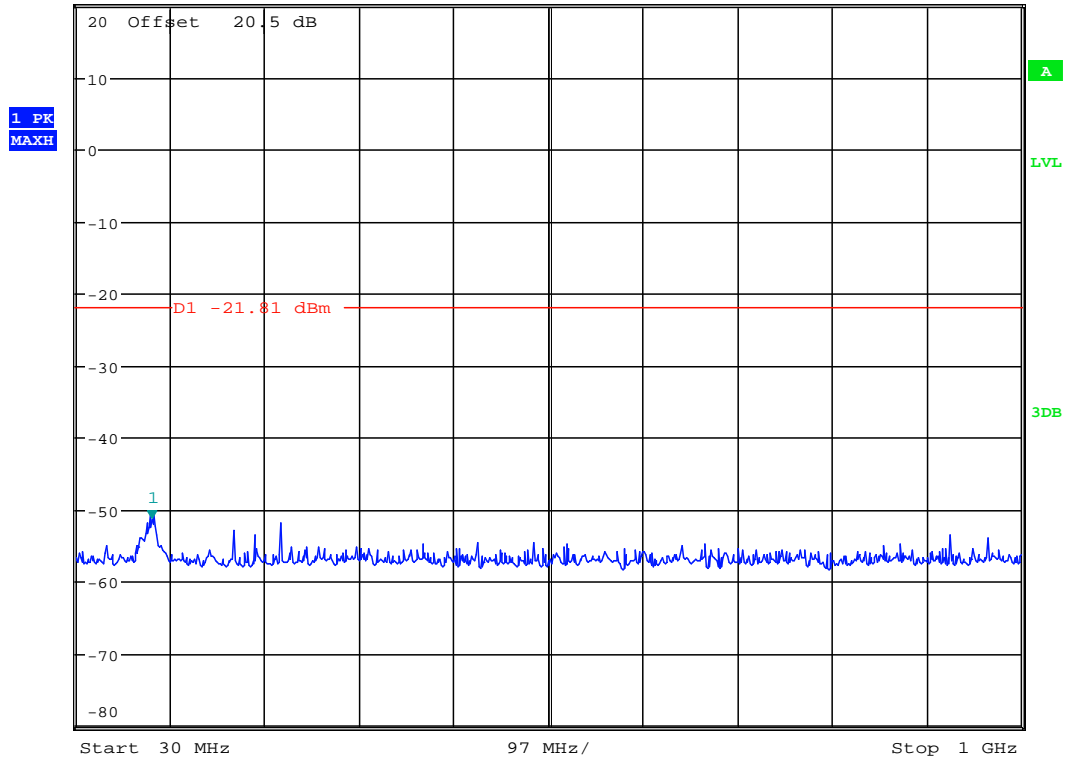

Ref 20 dBm *Att 10 dB *RBW 100 kHz Delta 2 [T1]
*VBW 300 kHz -44.63 dB
SWT 2.4 s 4.846153846 GHz

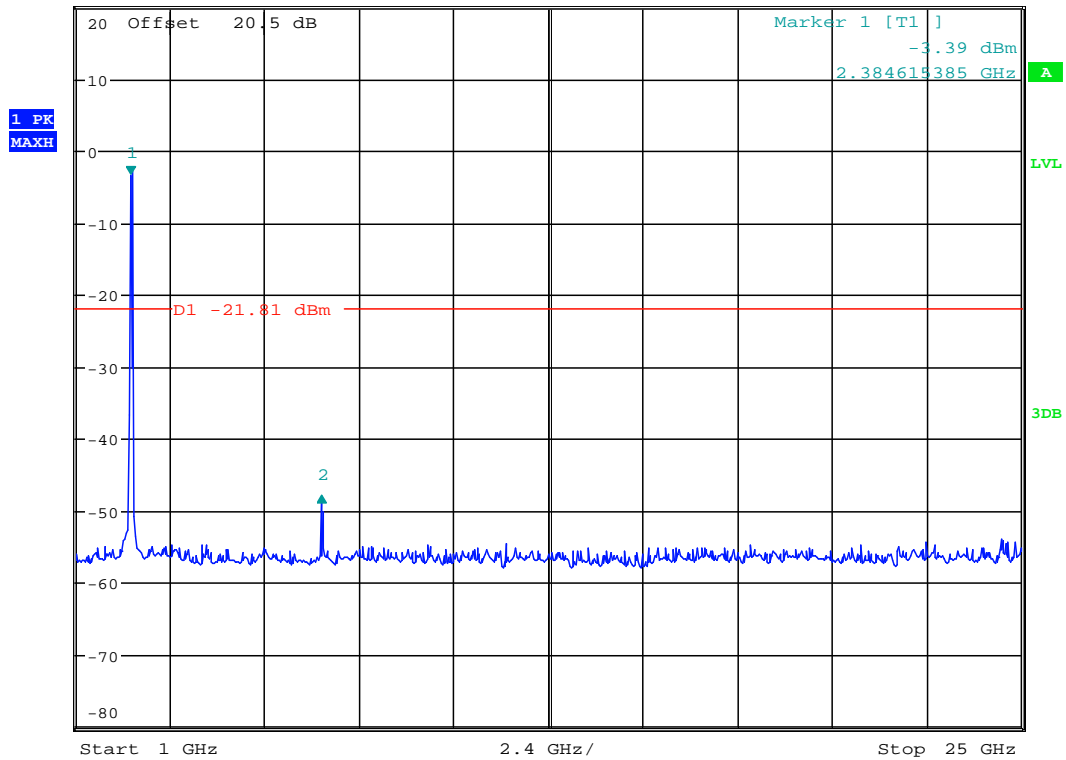

Chain 2 11n HT40 CH 6

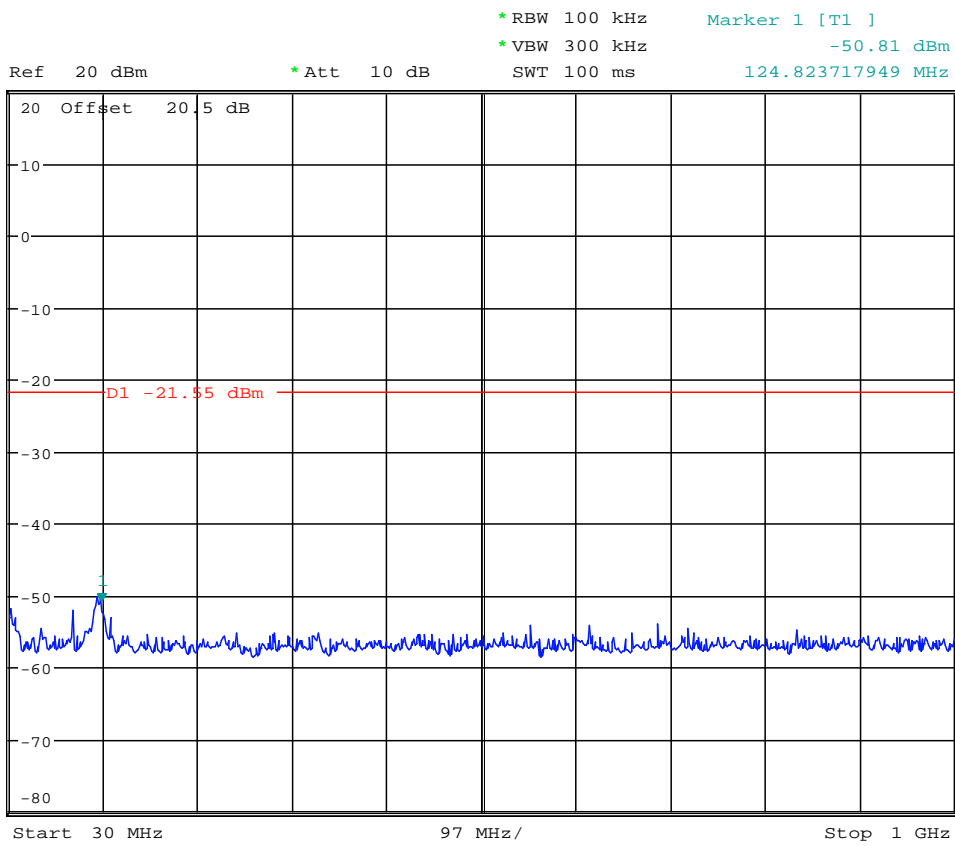
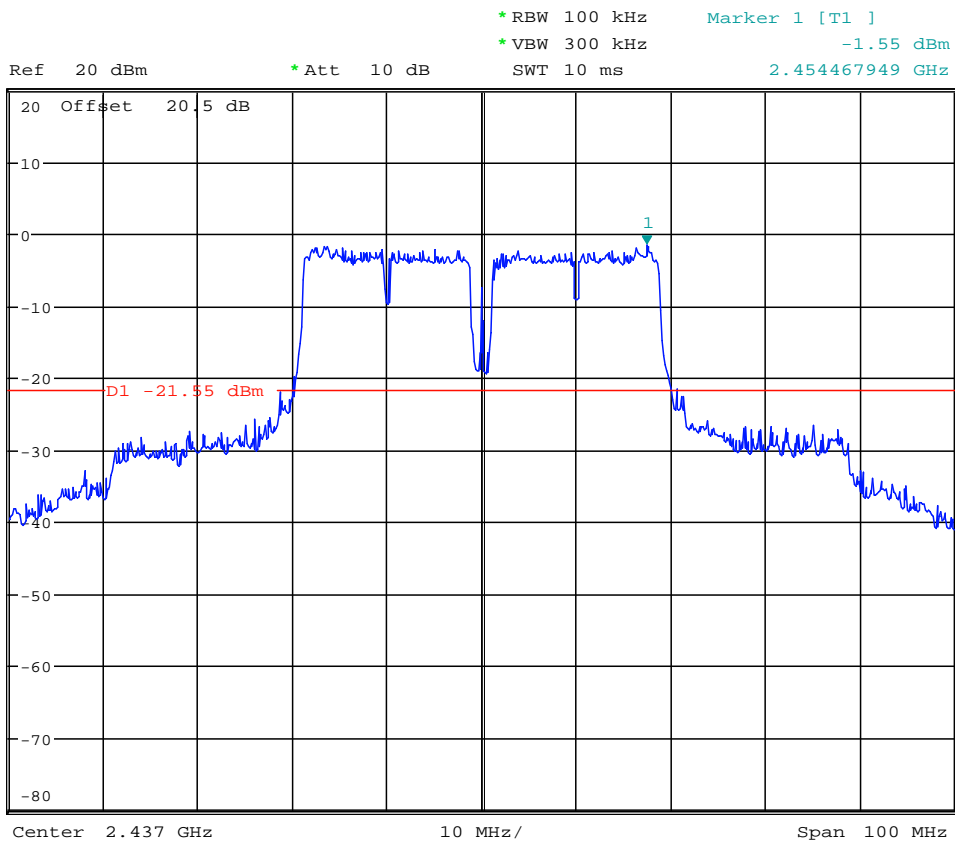

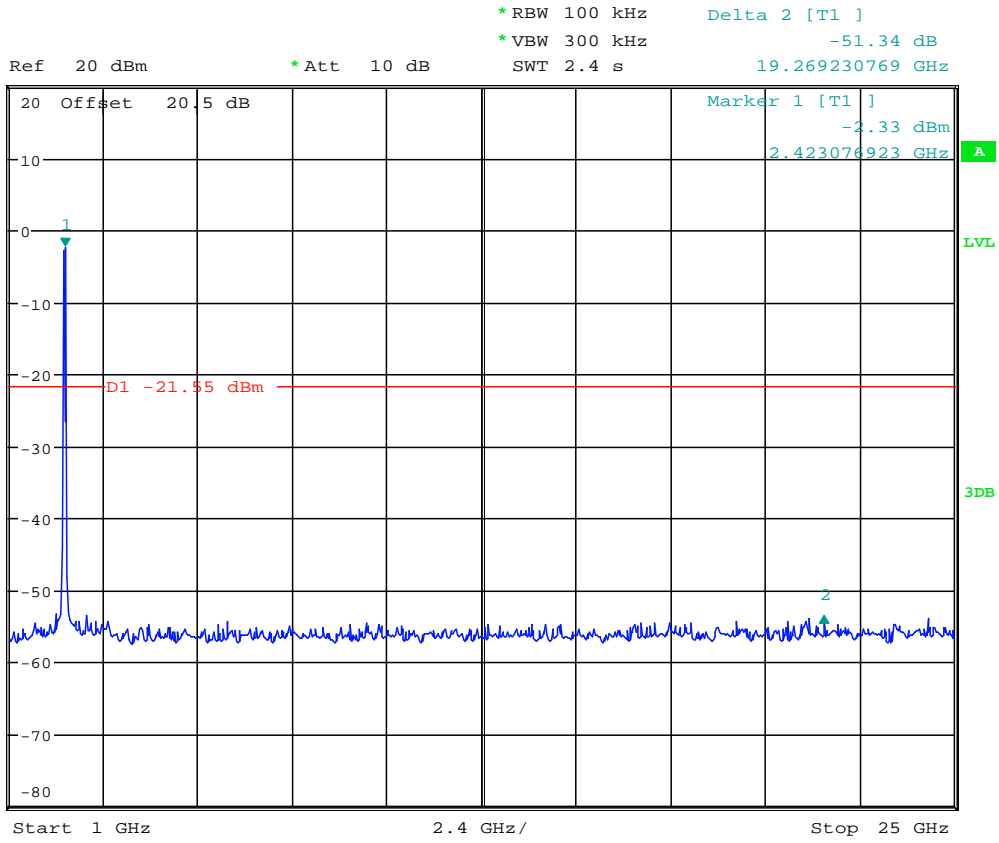

Chain 2 11n HT40 CH 9

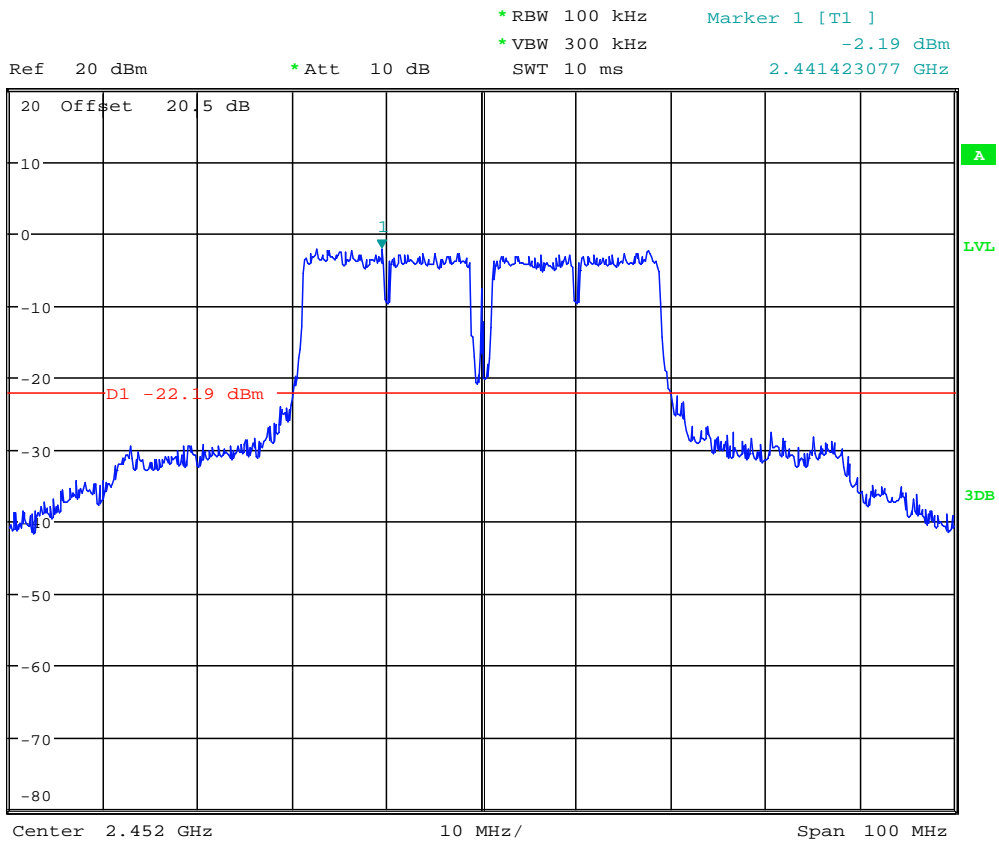

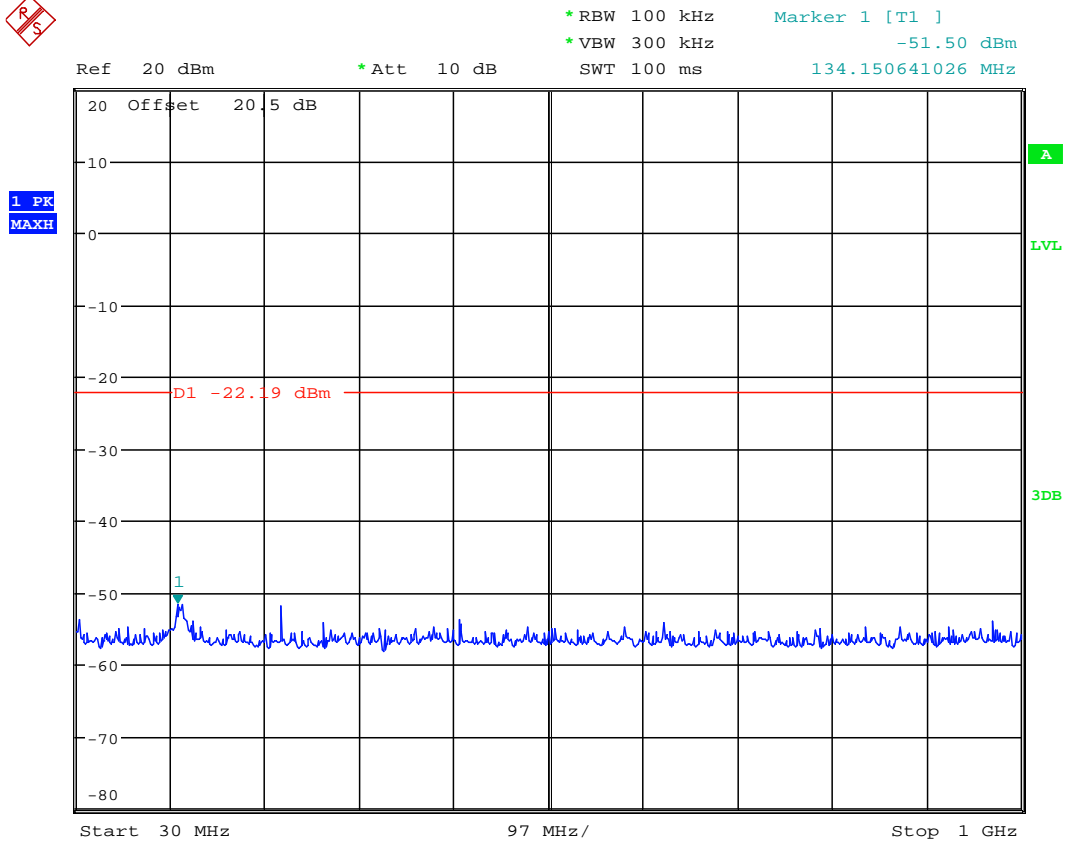
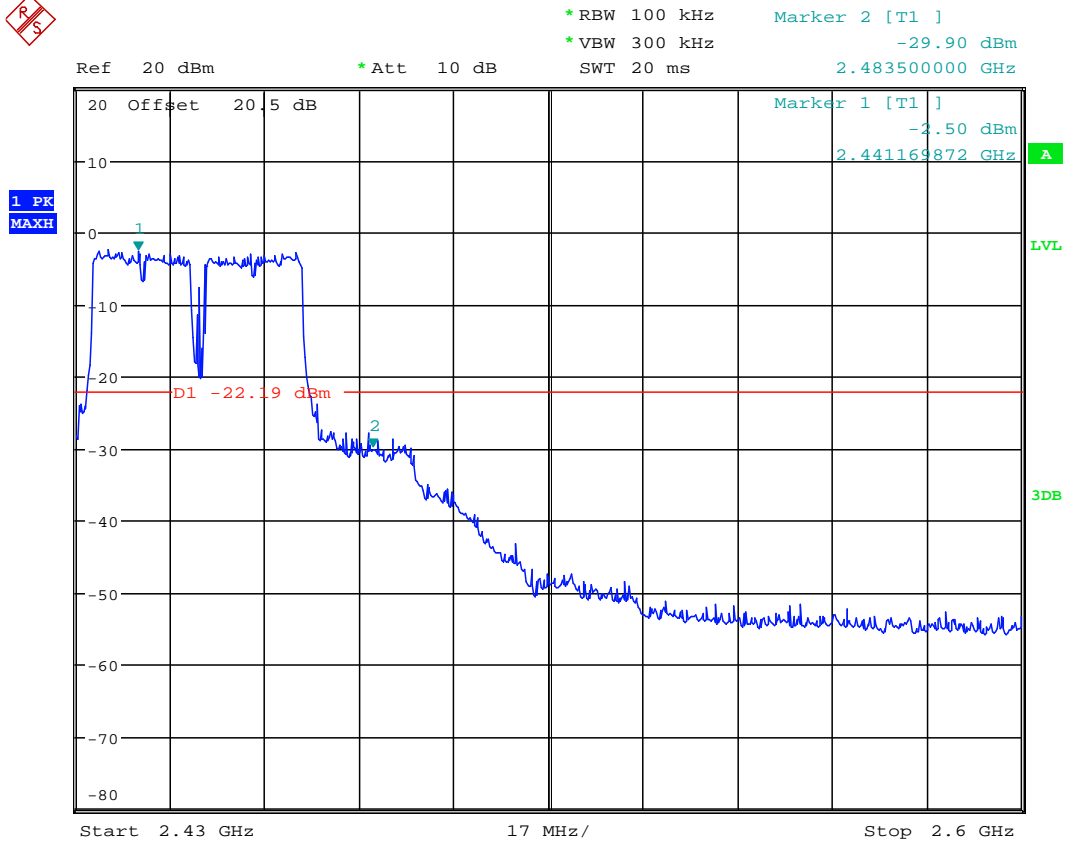

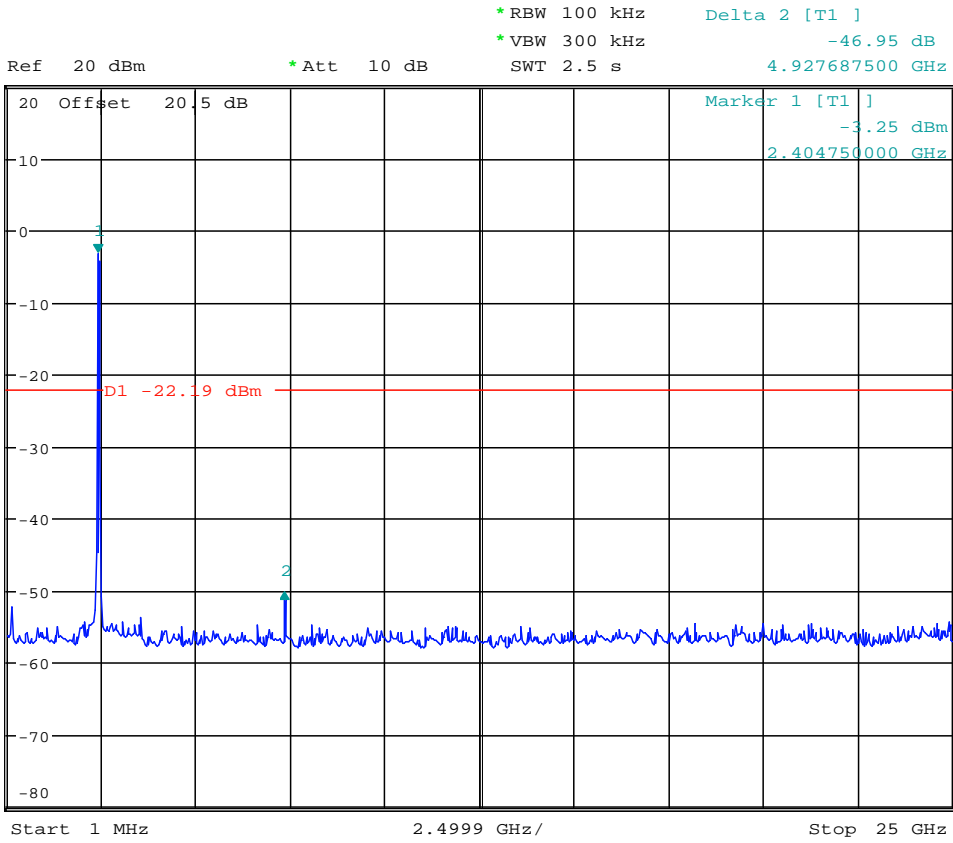

Chain 3 11b CH 1

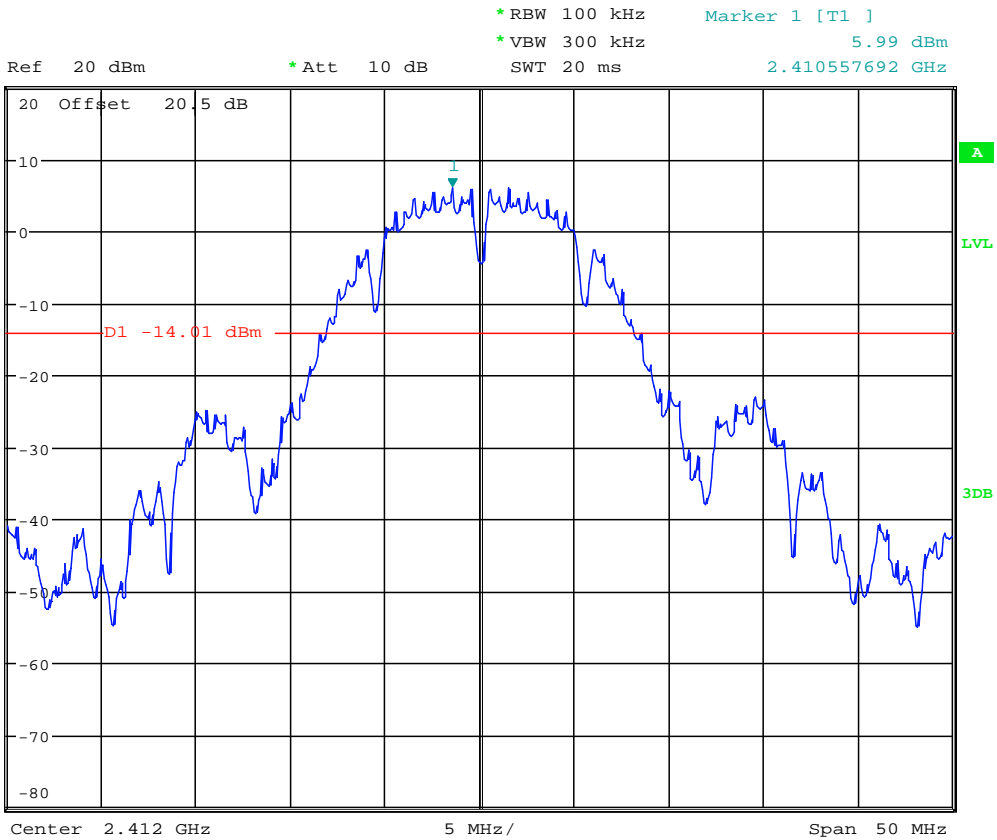

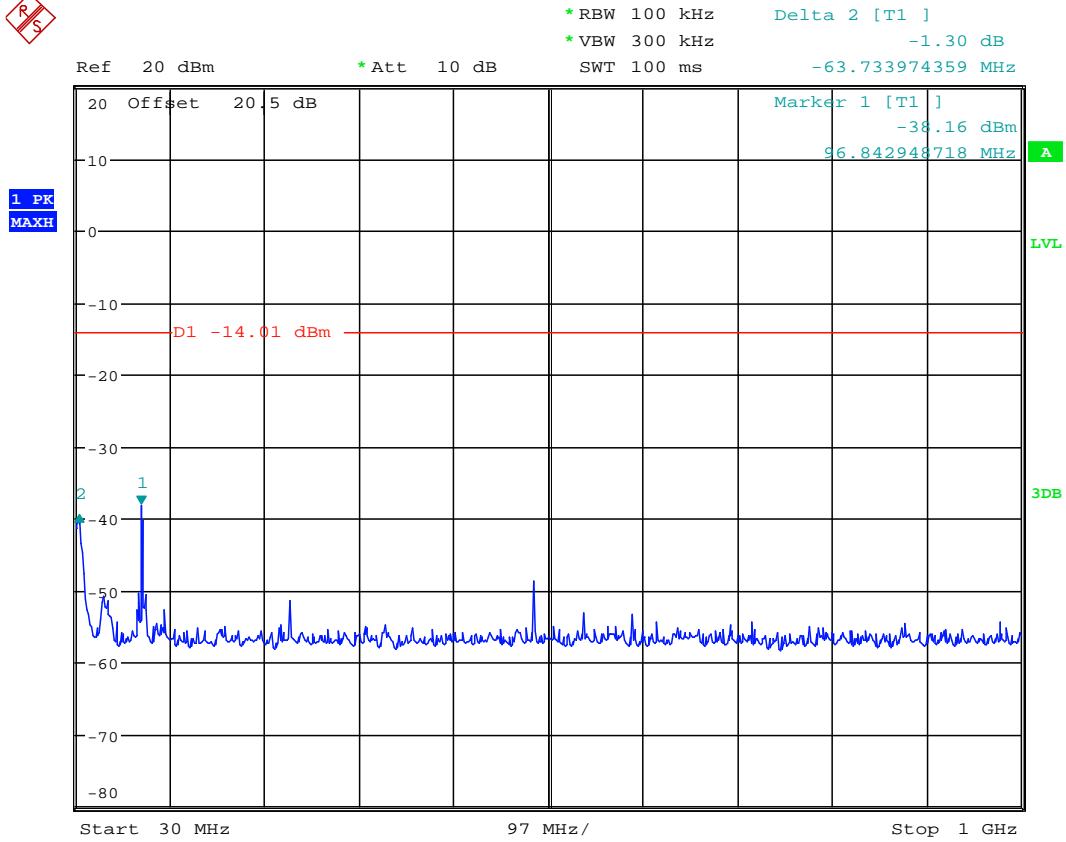
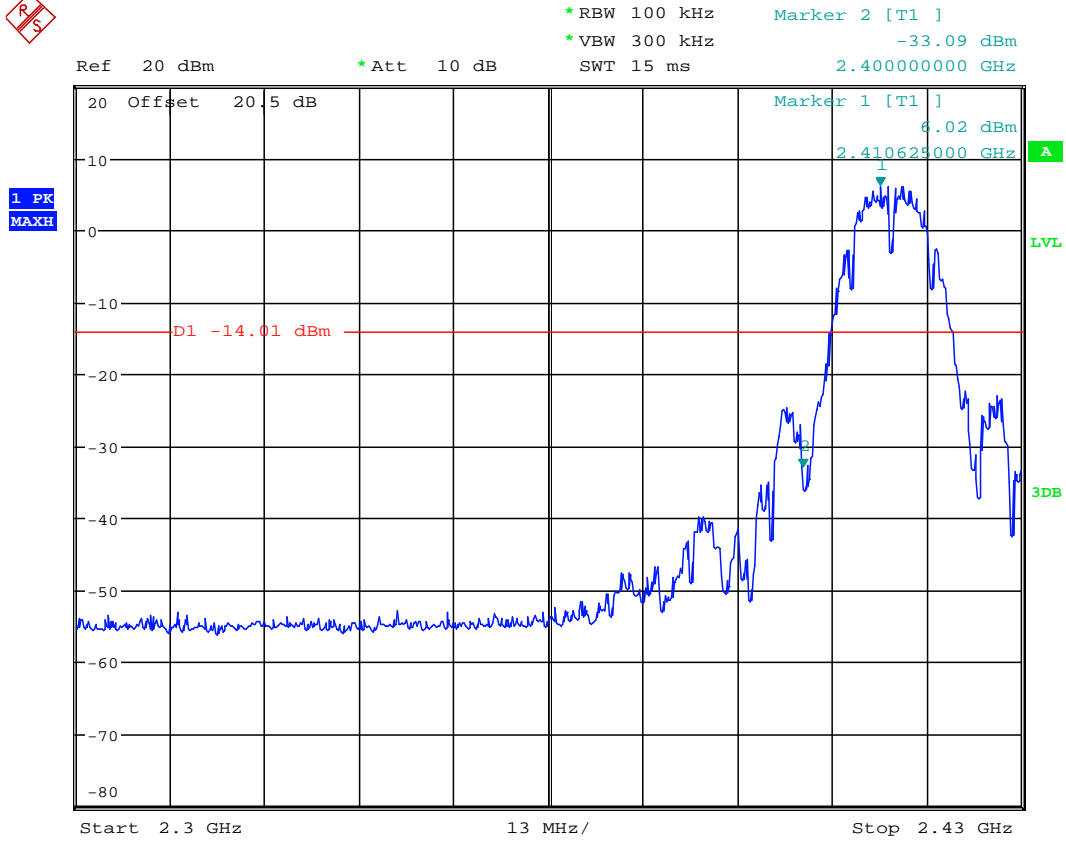

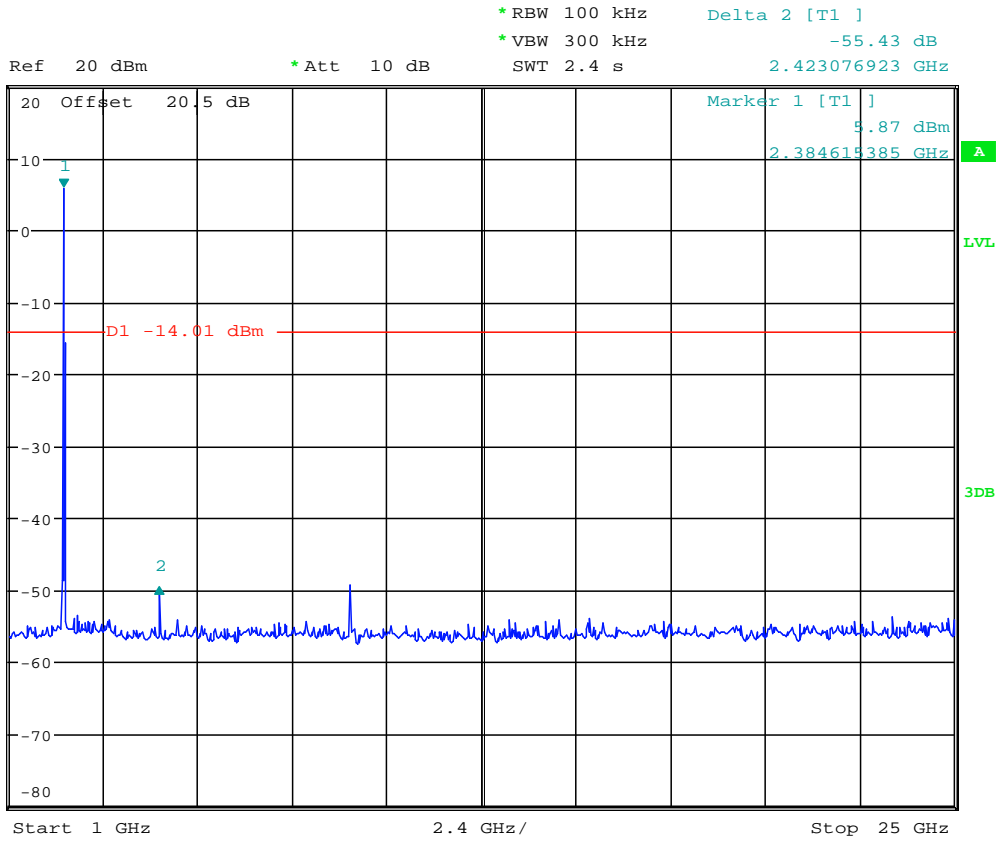

Chain 3 11b CH 6

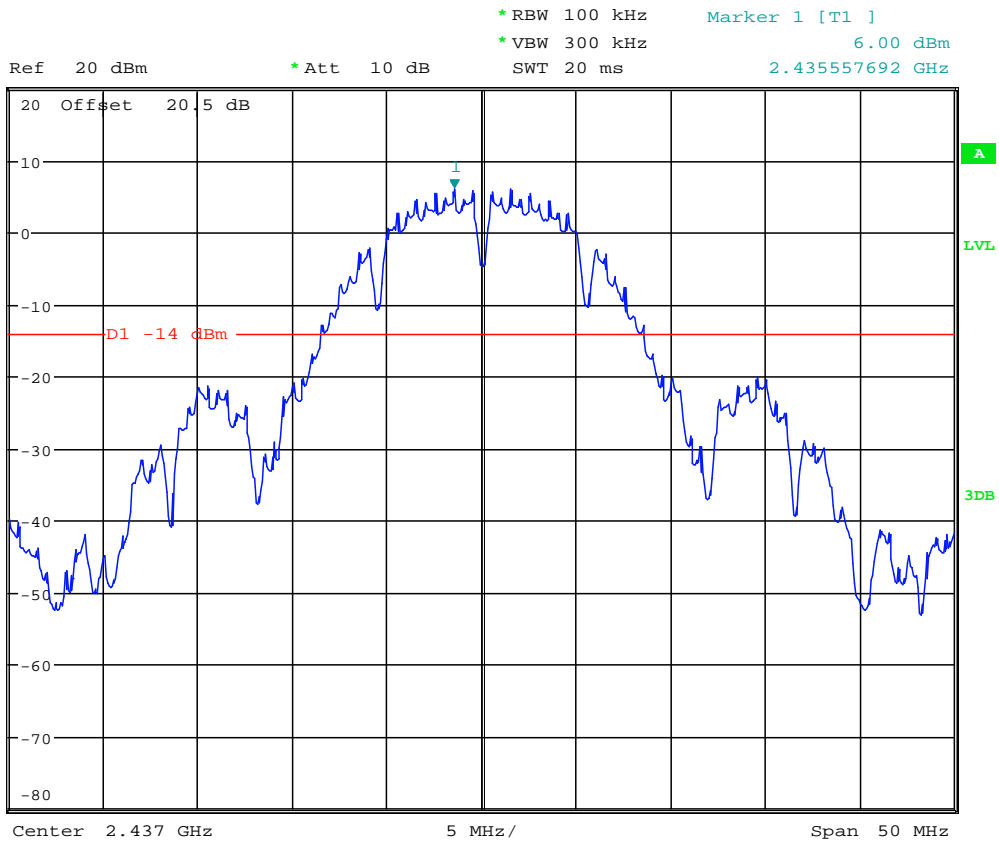



1 PK
MAXH

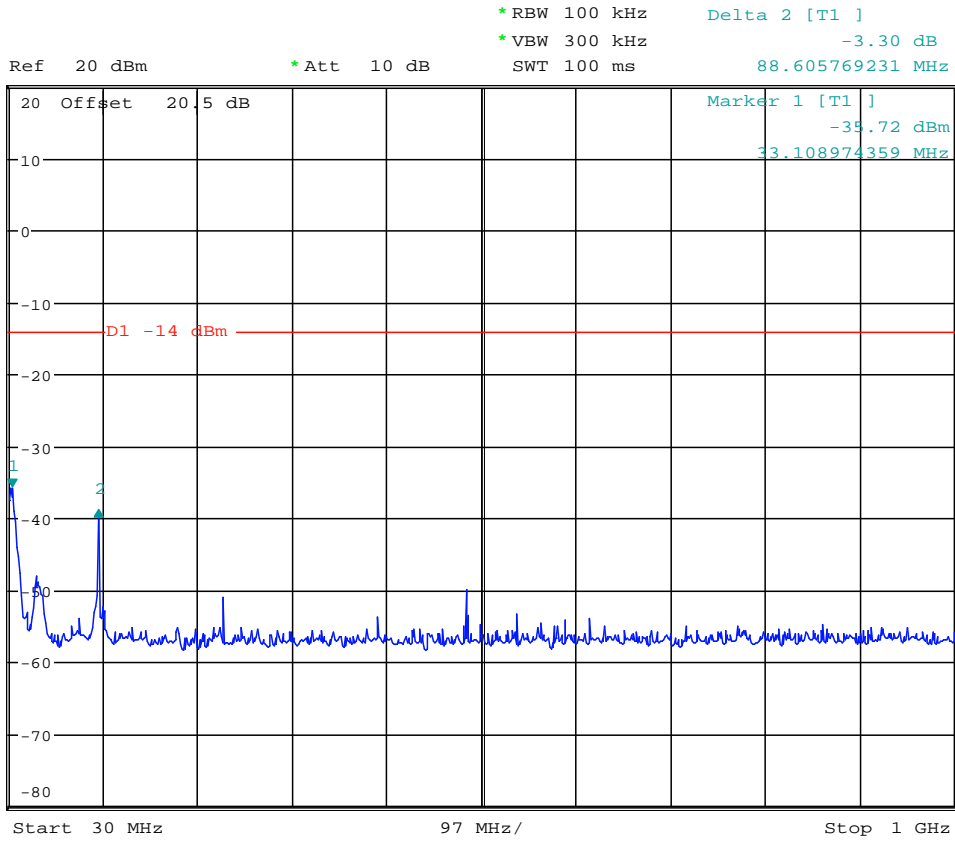

1 PK
MAXH

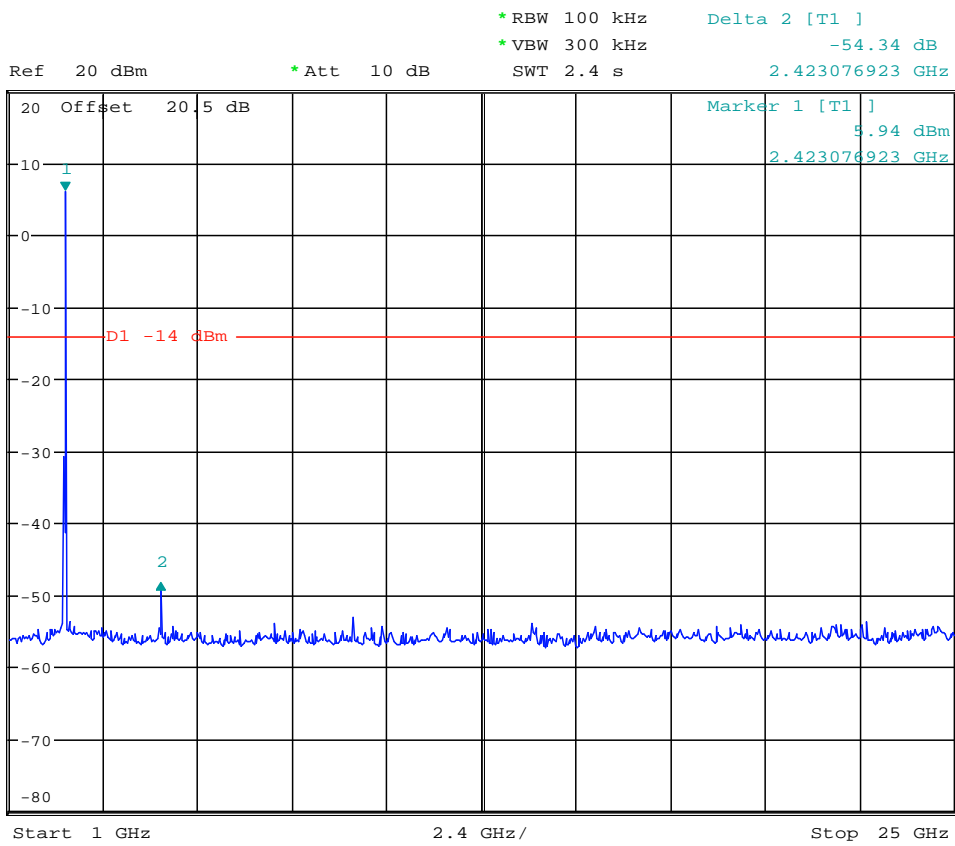

Chain 3 11b CH 11



*RBW 100 kHz Marker 2 [T1]
 *VBW 300 kHz -43.88 dBm
 SWT 15 ms 2.483500000 GHz

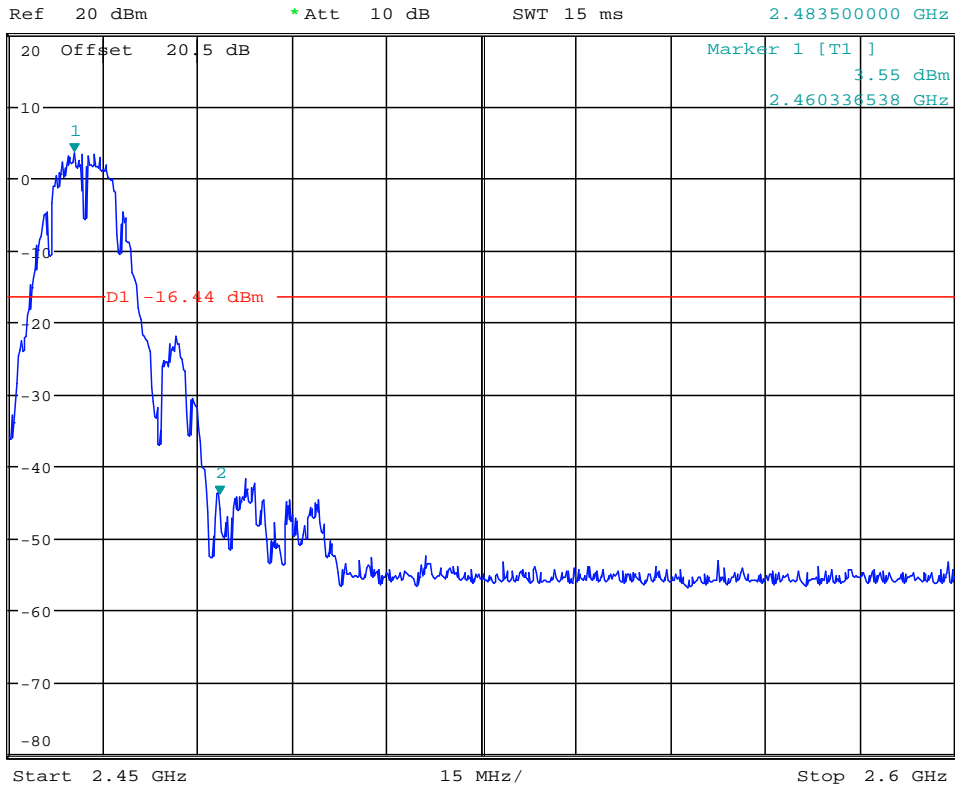

*RBW 100 kHz Marker 1 [T1]
 *VBW 300 kHz 3.56 dBm
 SWT 20 ms 2.460557692 GHz

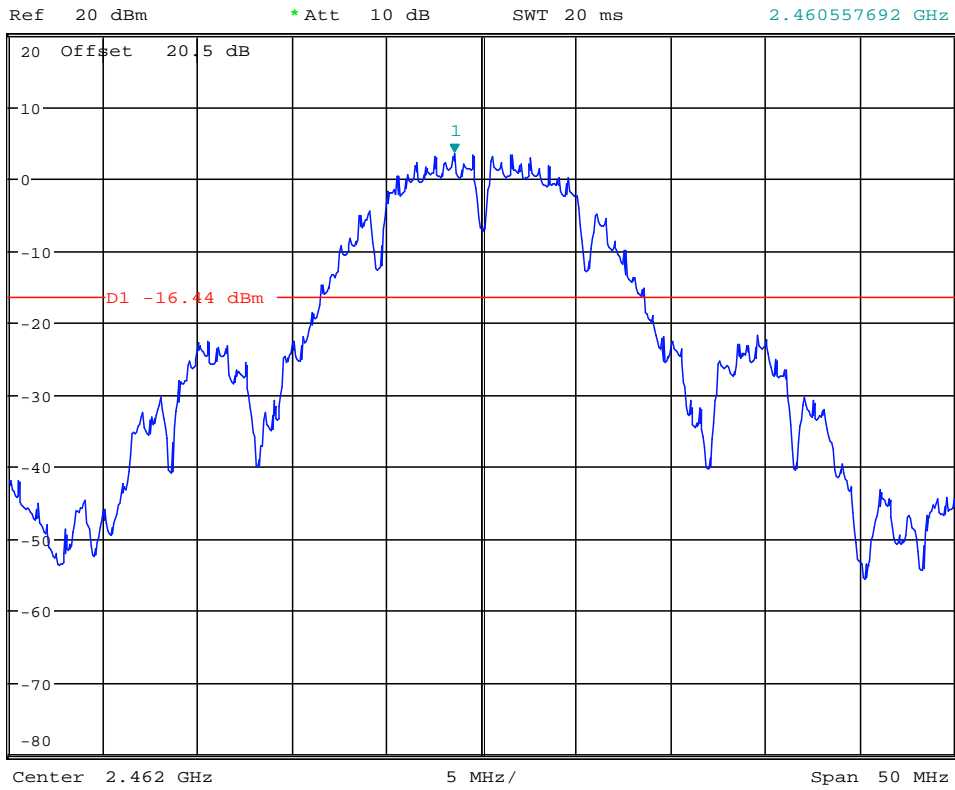

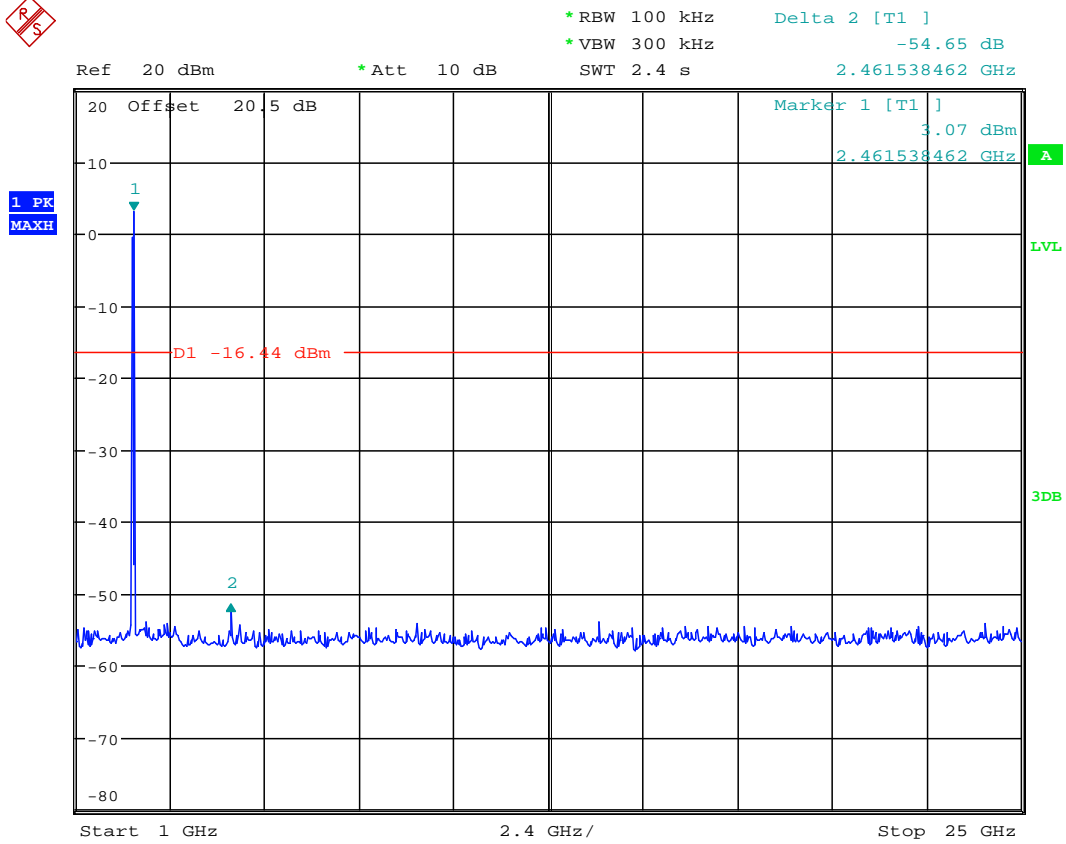
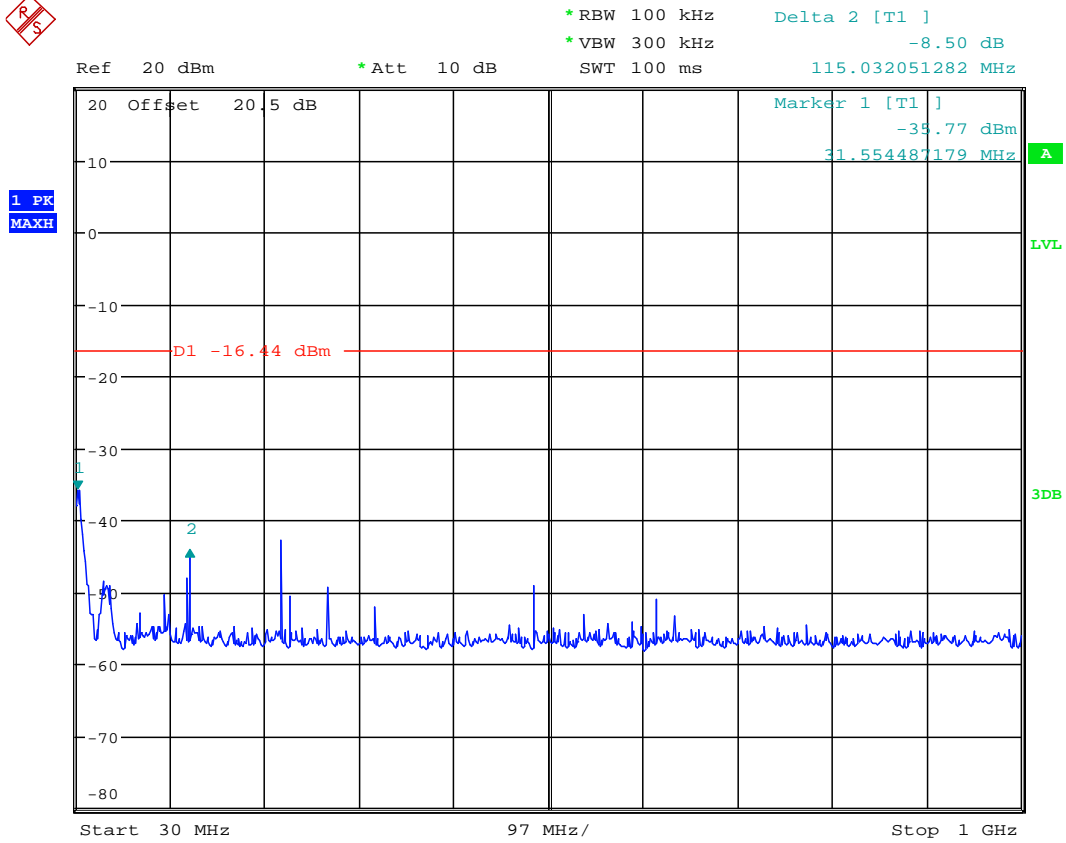

Chain 3 11g CH 1

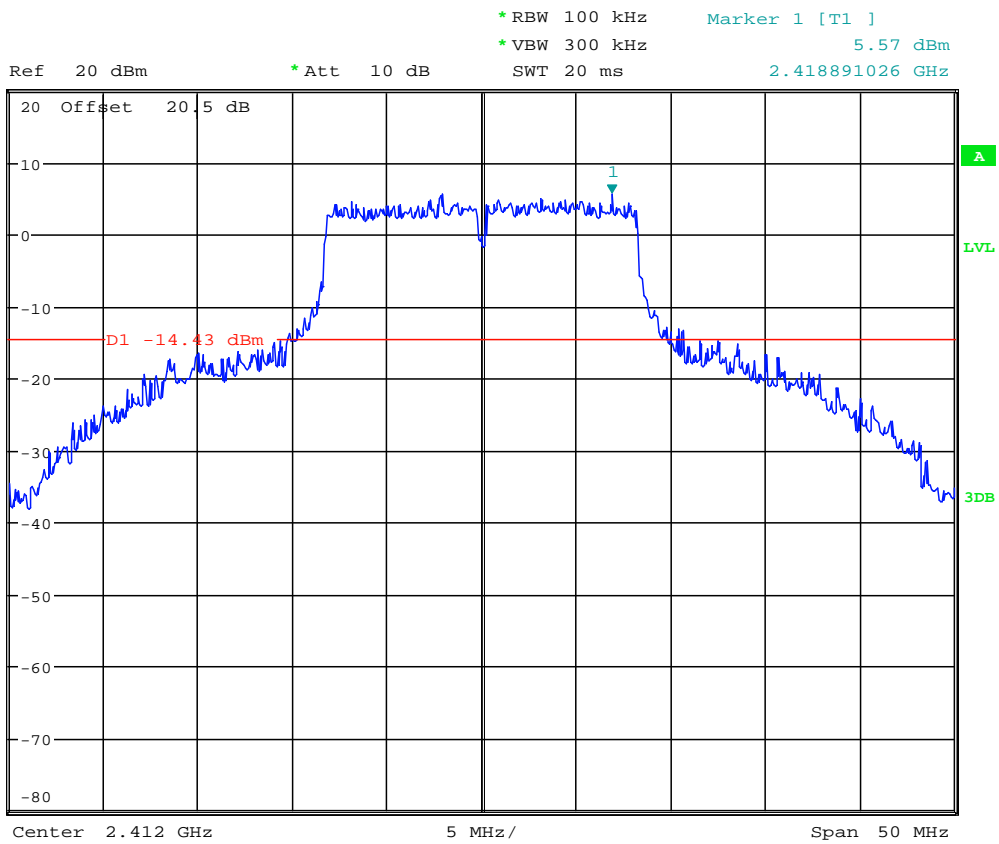
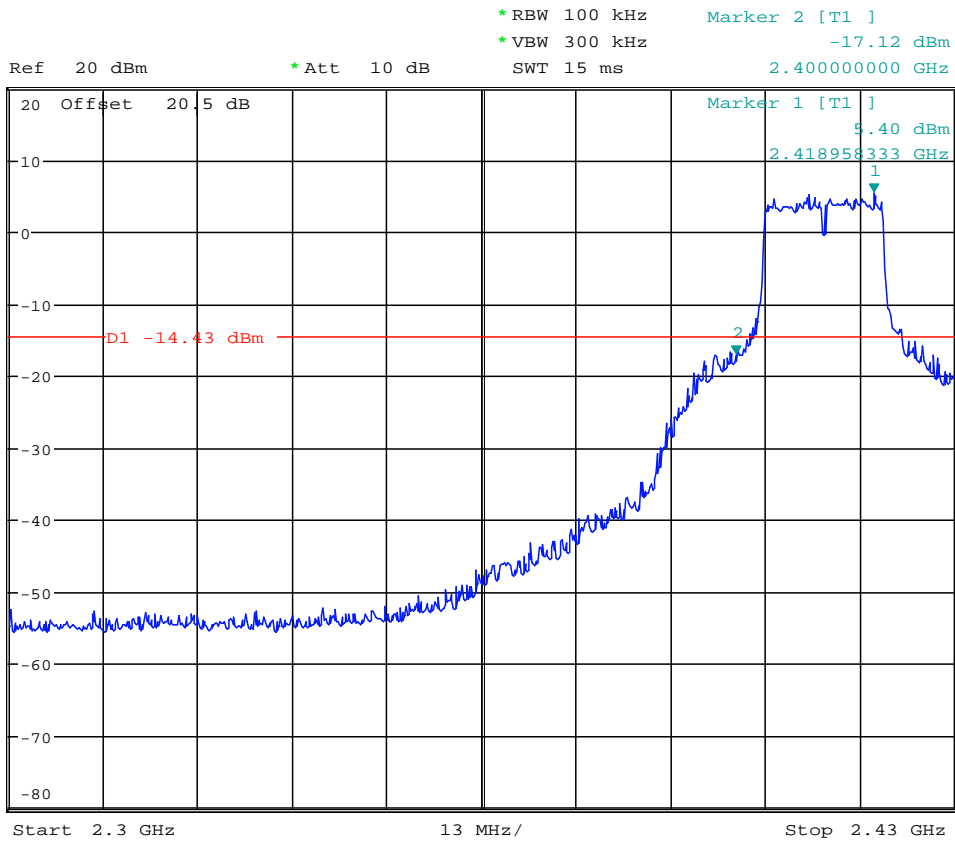



Ref 20 dBm *Att 10 dB *RBW 100 kHz Marker 1 [T1]
*VBW 300 kHz -40.96 dBm
SWT 100 ms 98.397435897 MHz

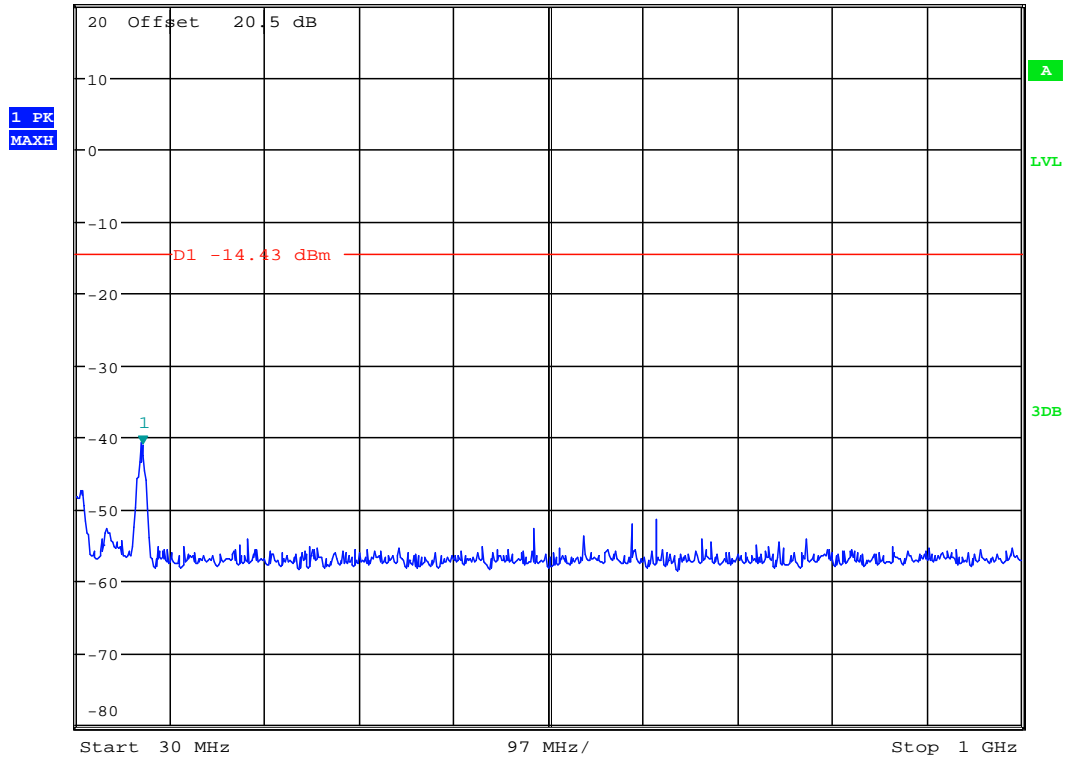

Ref 20 dBm *Att 10 dB *RBW 100 kHz Delta 2 [T1]
*VBW 300 kHz -59.60 dB
SWT 2.4 s 3.615384615 GHz

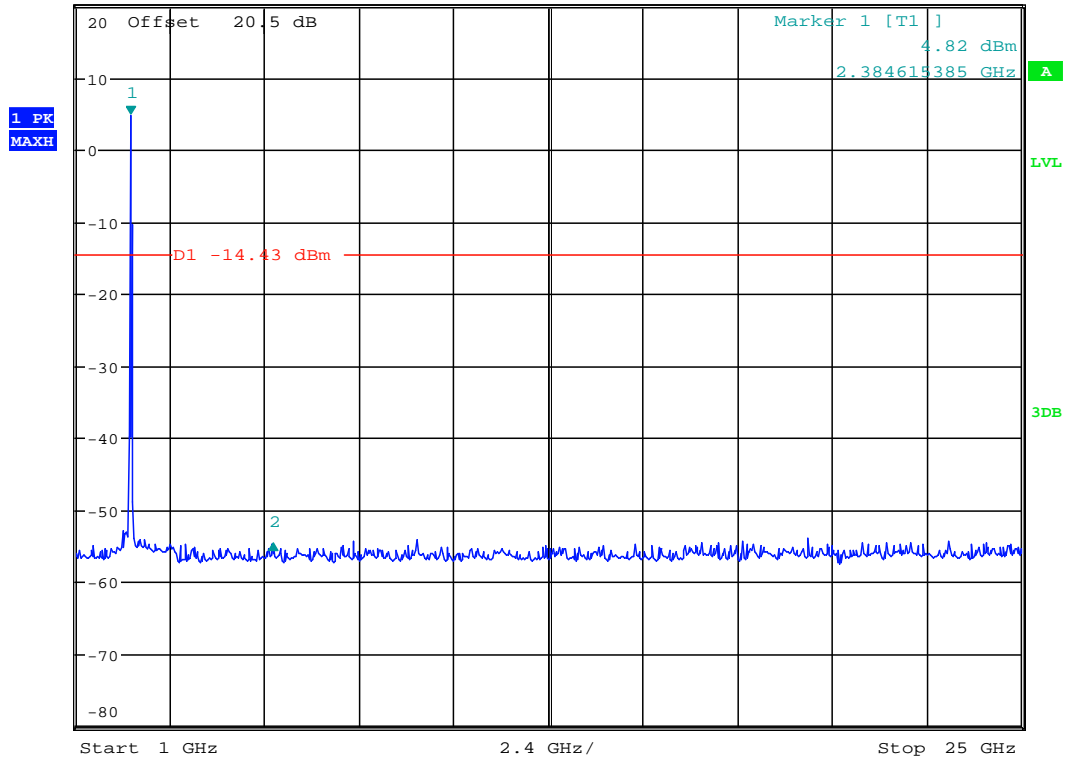

Chain 3 11g CH 6



*RBW 100 kHz Marker 1 [T1]
*VBW 300 kHz 4.33 dBm
SWT 20 ms 2.443891026 GHz

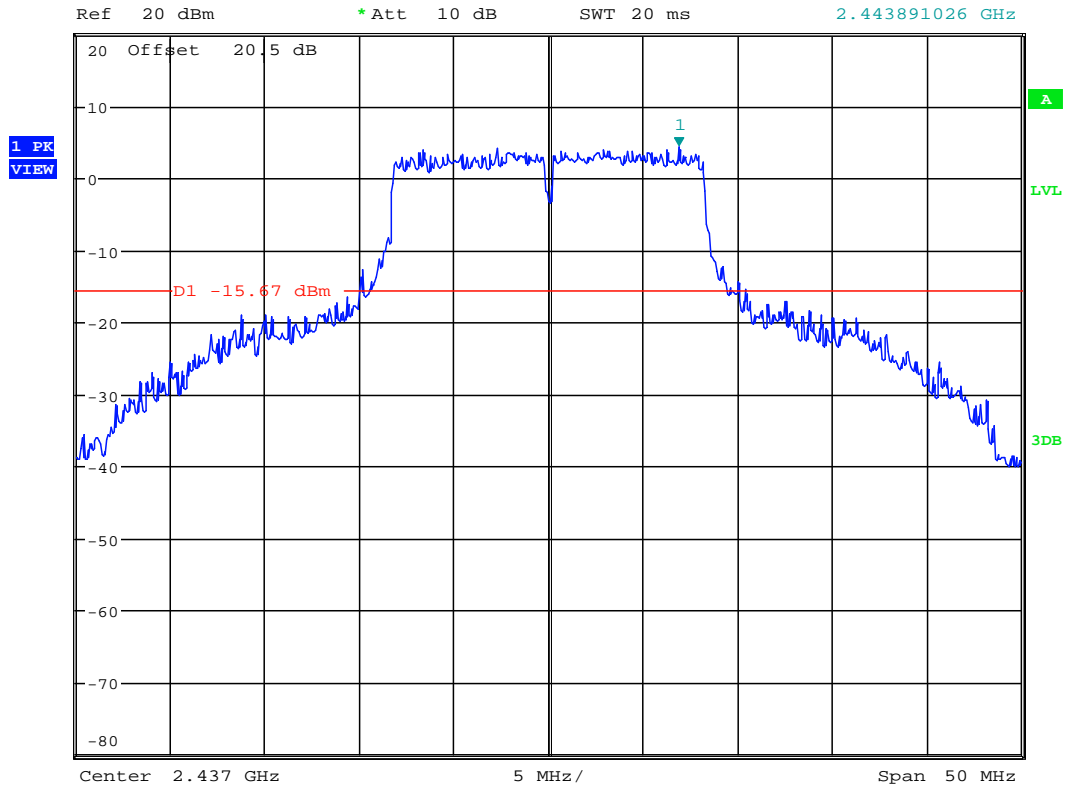

*RBW 100 kHz Marker 1 [T1]
*VBW 300 kHz -44.54 dBm
SWT 100 ms 121.714743590 MHz

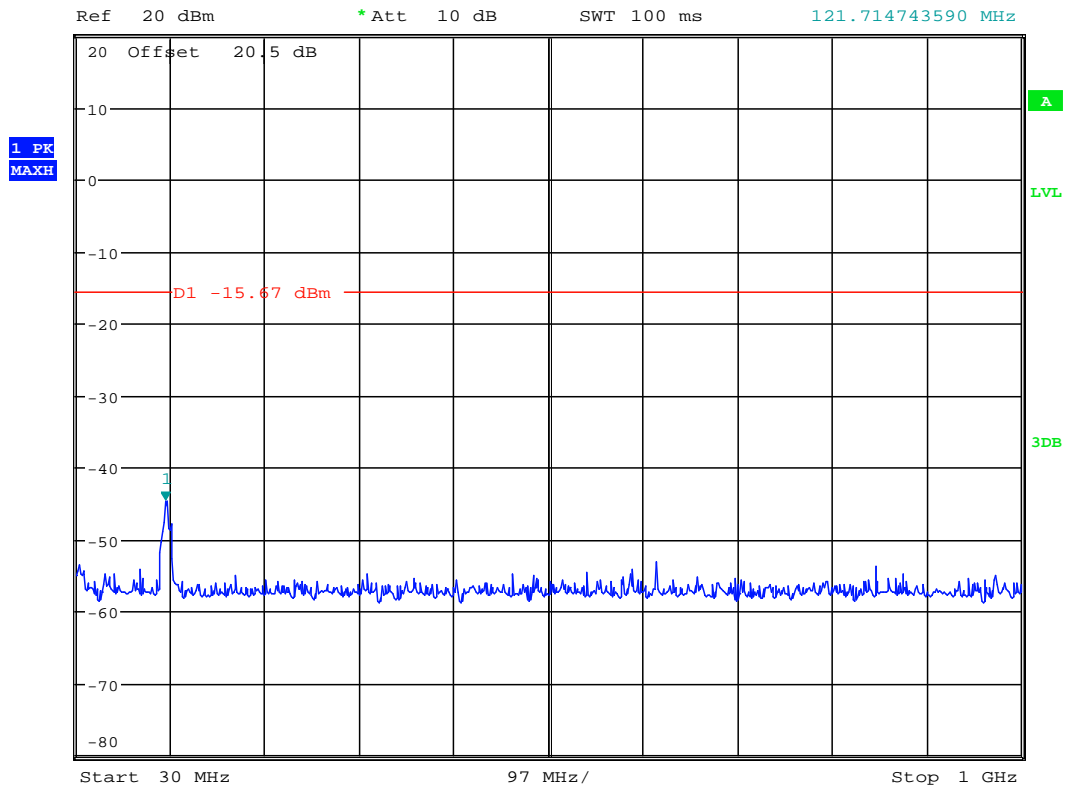

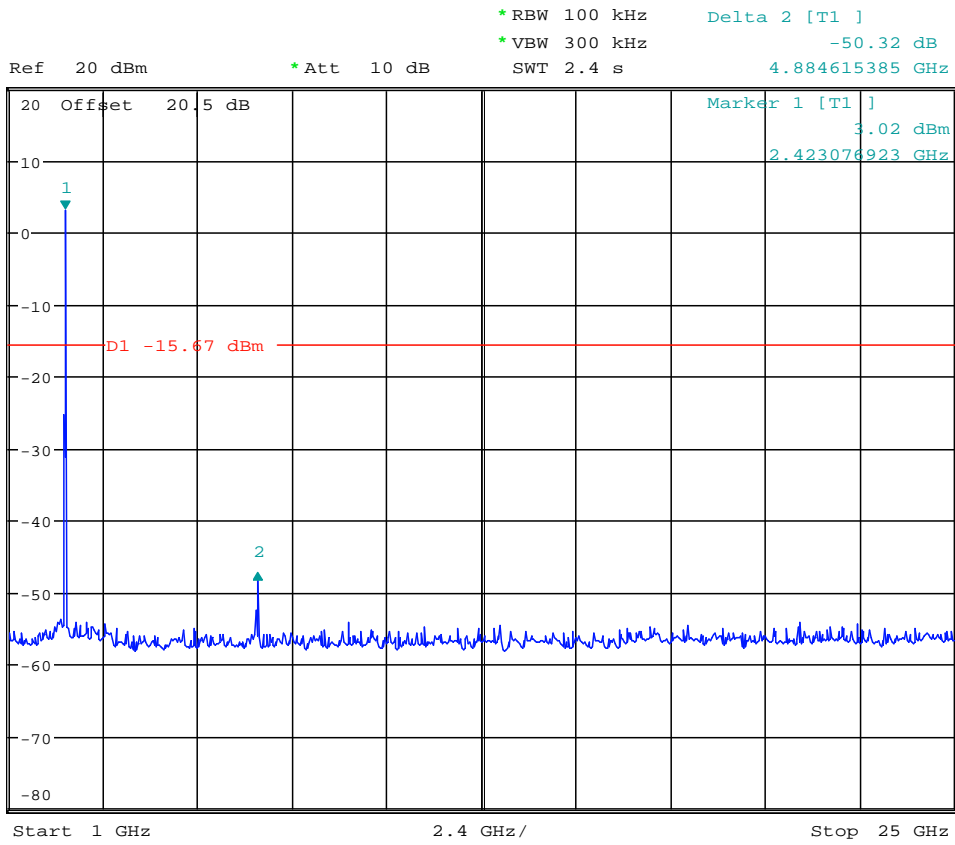

Chain 3 11g CH 11

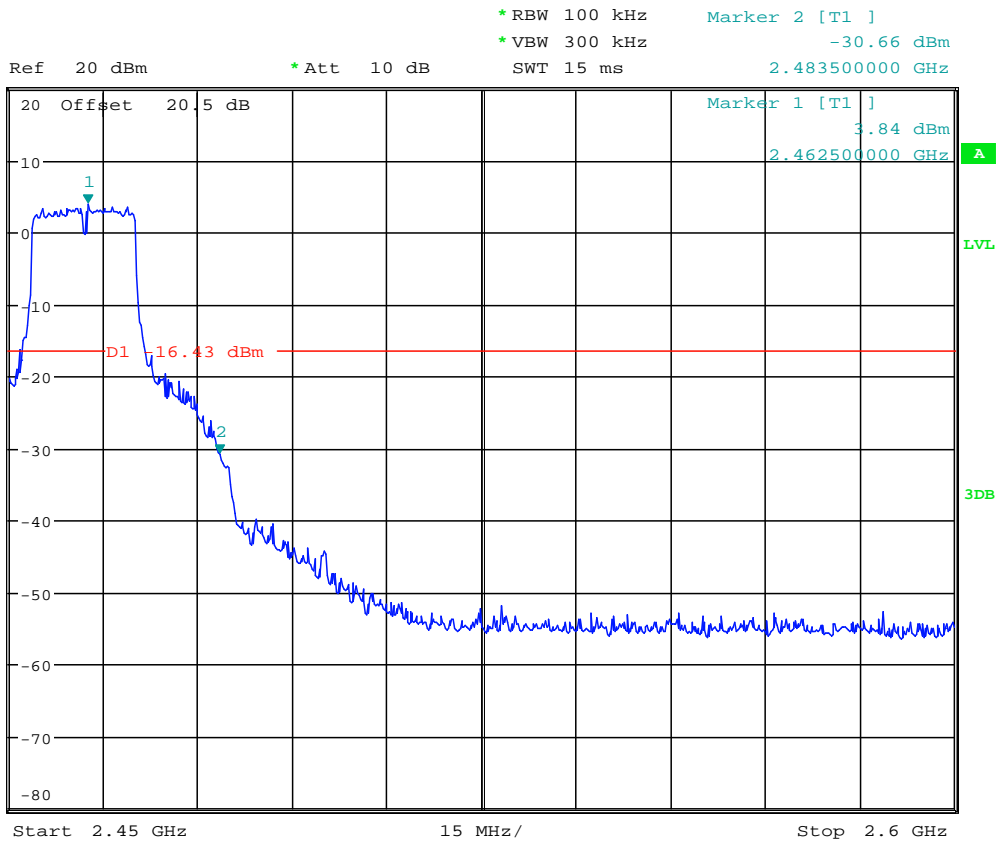

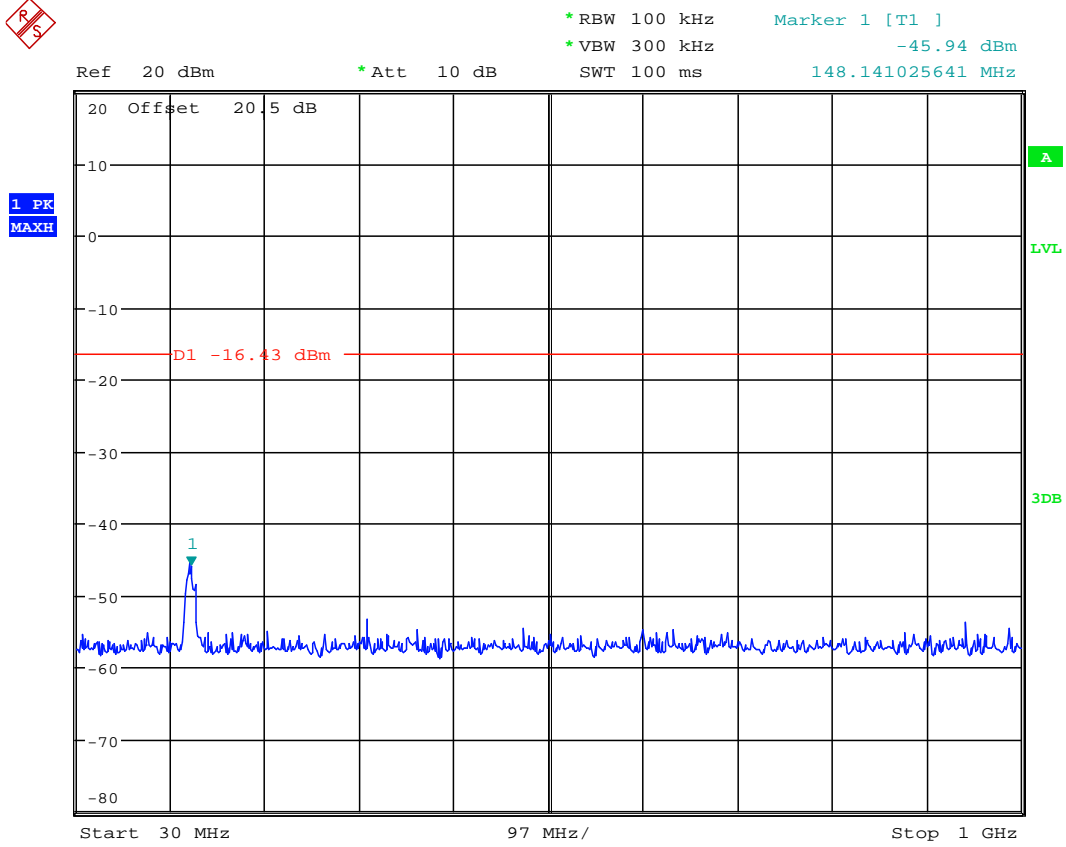
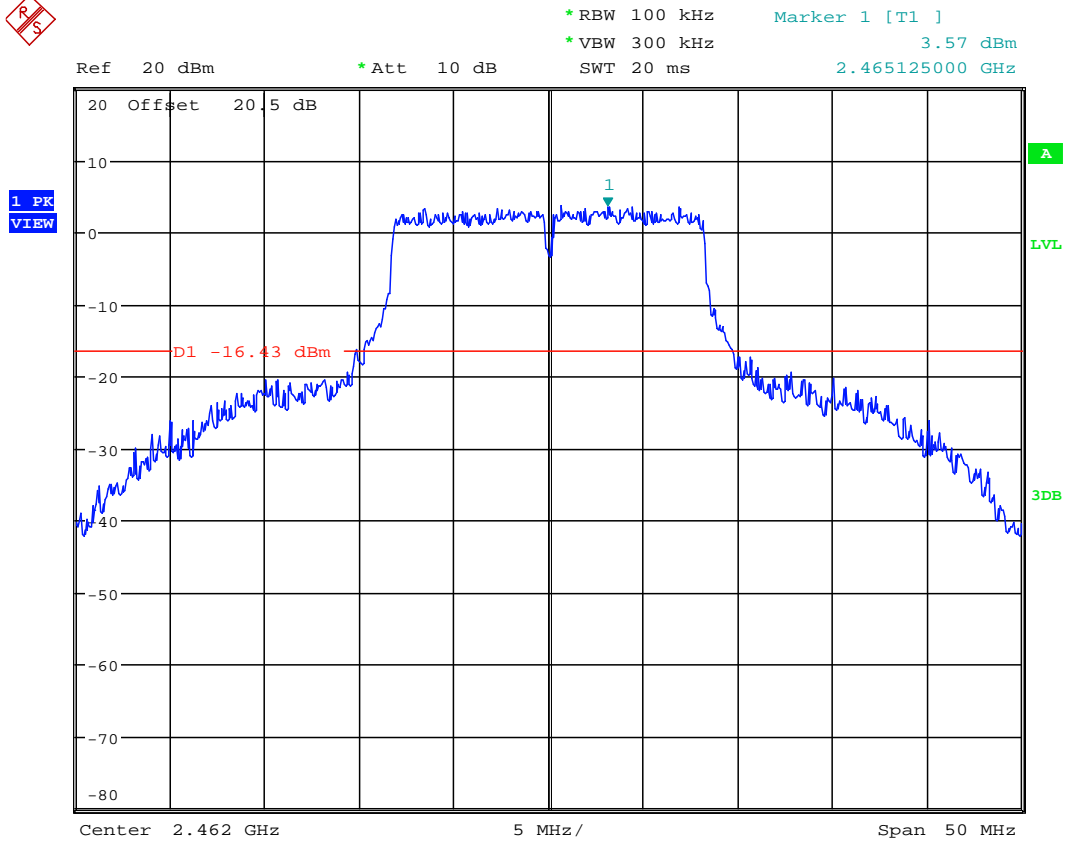

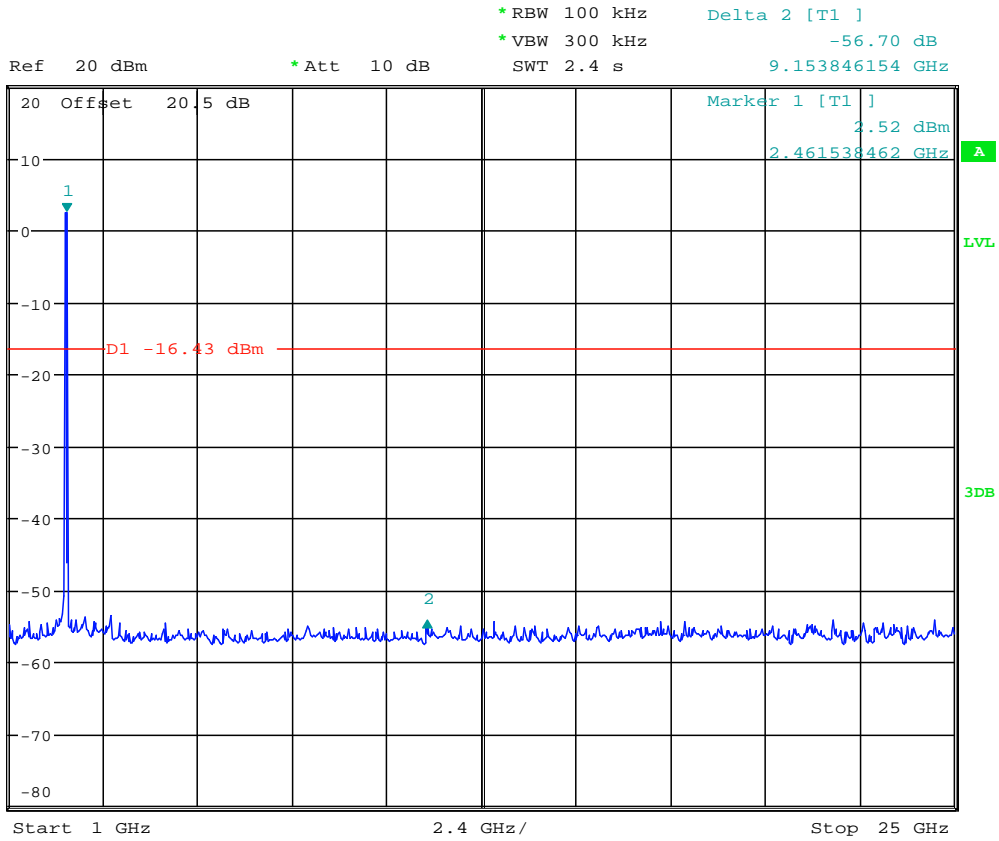

Chain 3 11n HT20 CH 1

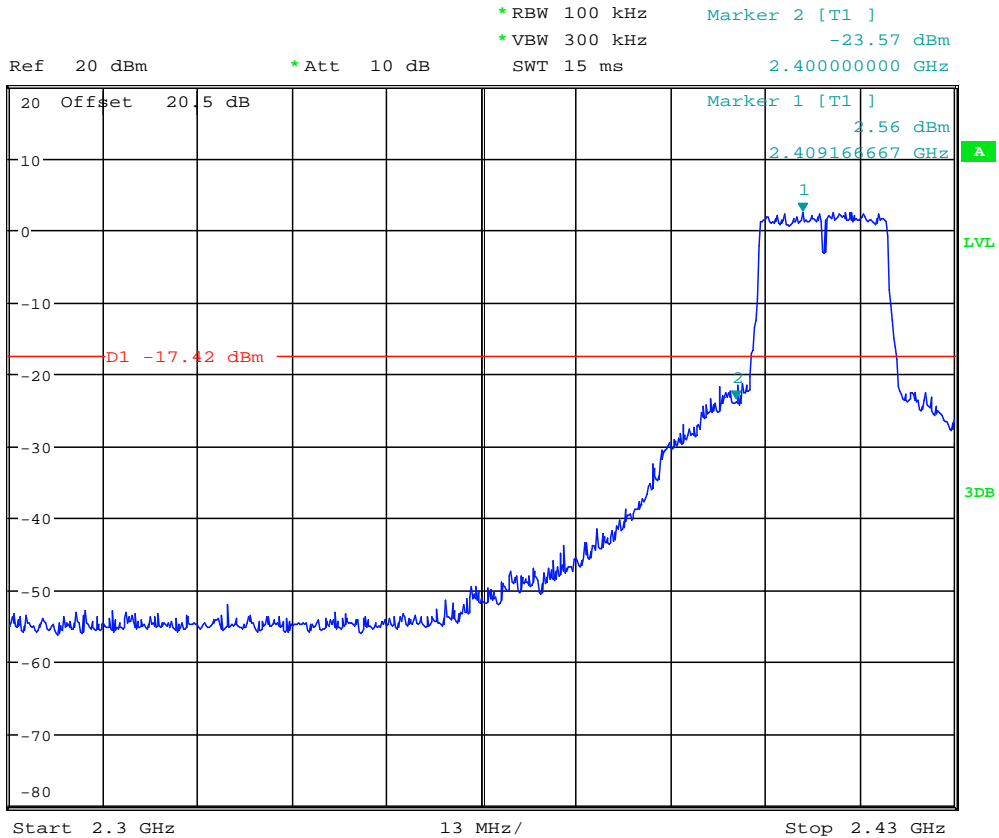

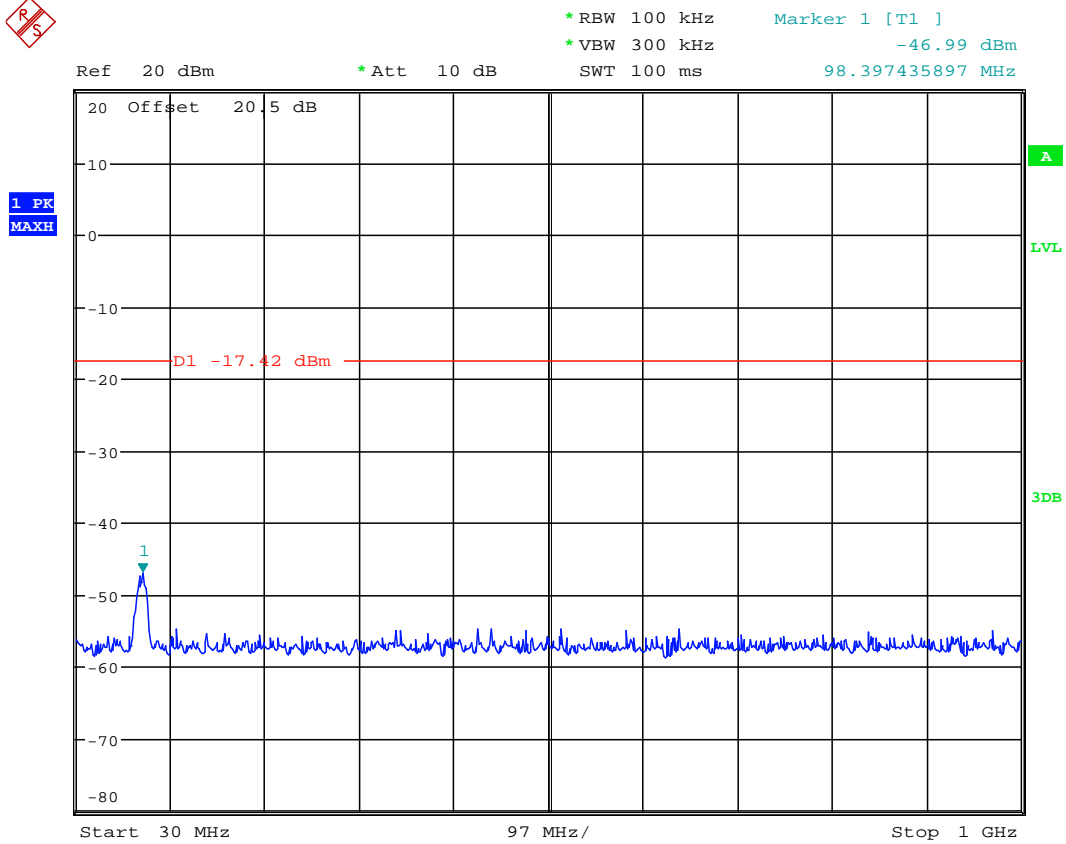
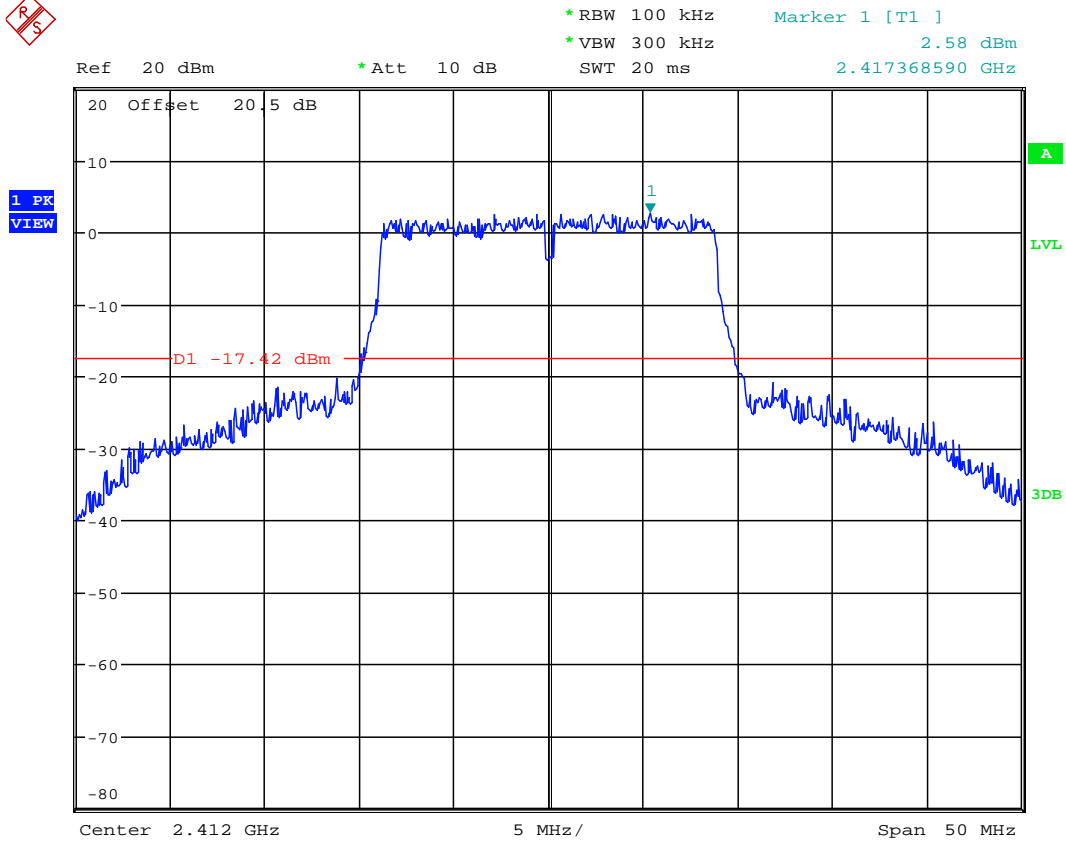

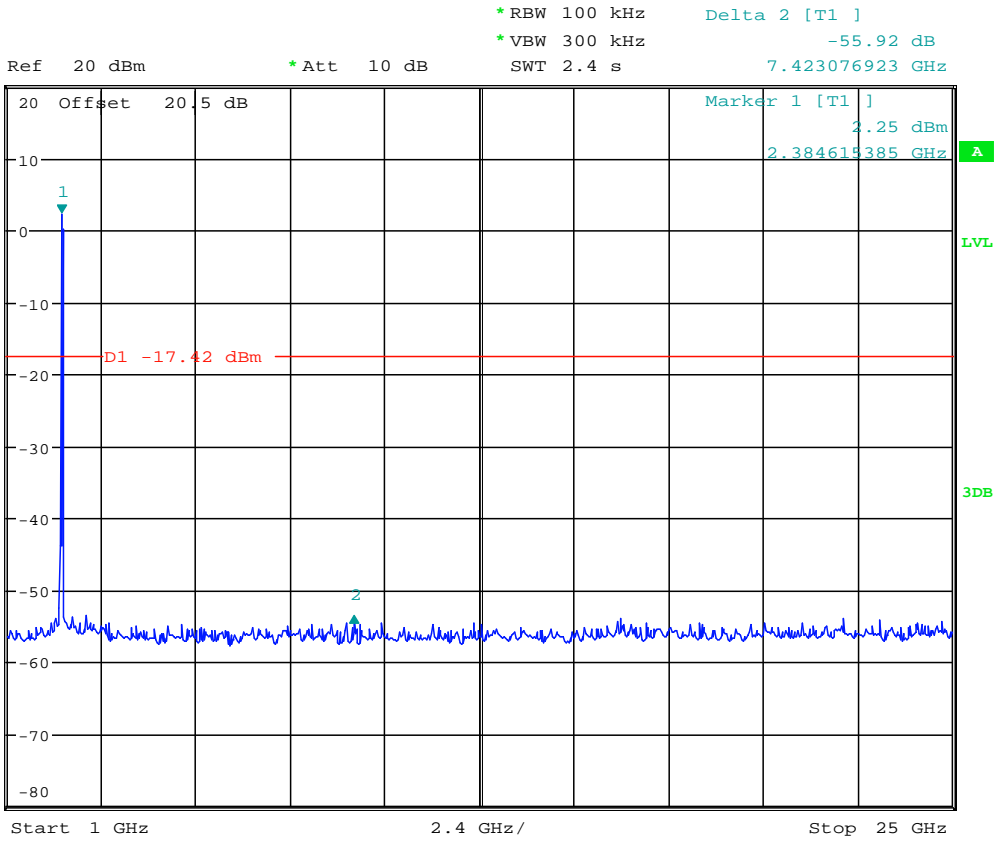

Chain 3 11n HT20 CH 6

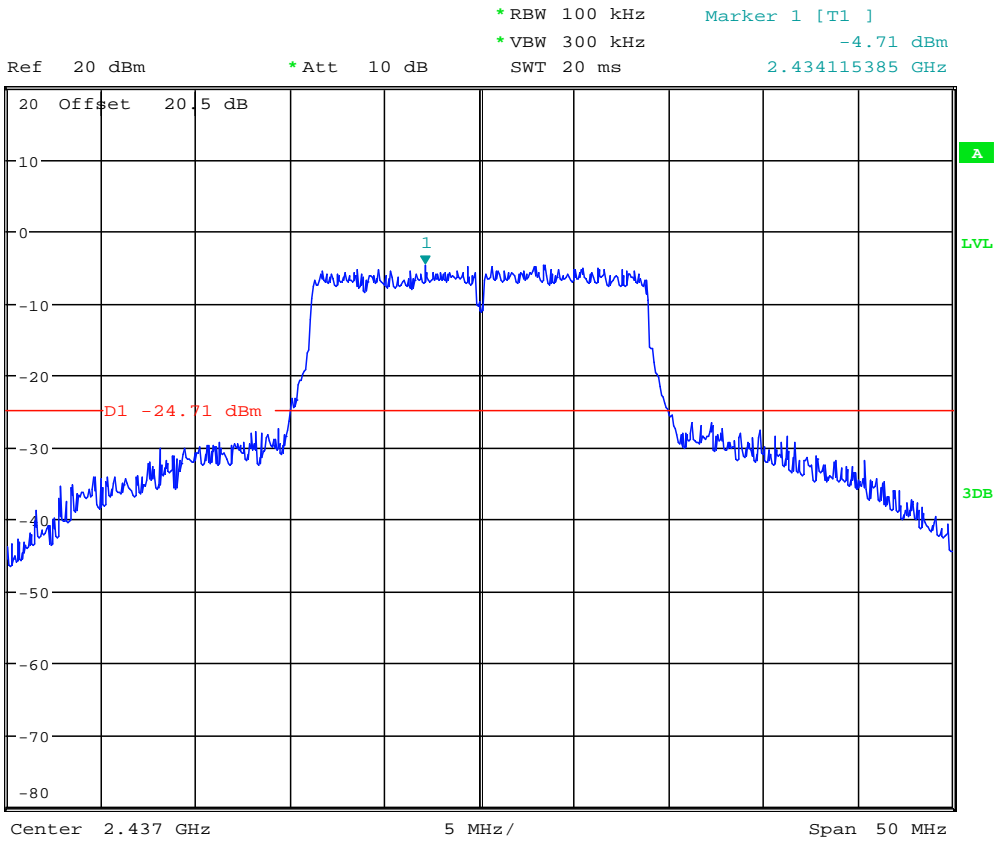



Ref 20 dBm *Att 10 dB *RBW 100 kHz Marker 1 [T1] -43.49 dBm
*VBW 300 kHz 33.108974359 MHz
SWT 100 ms

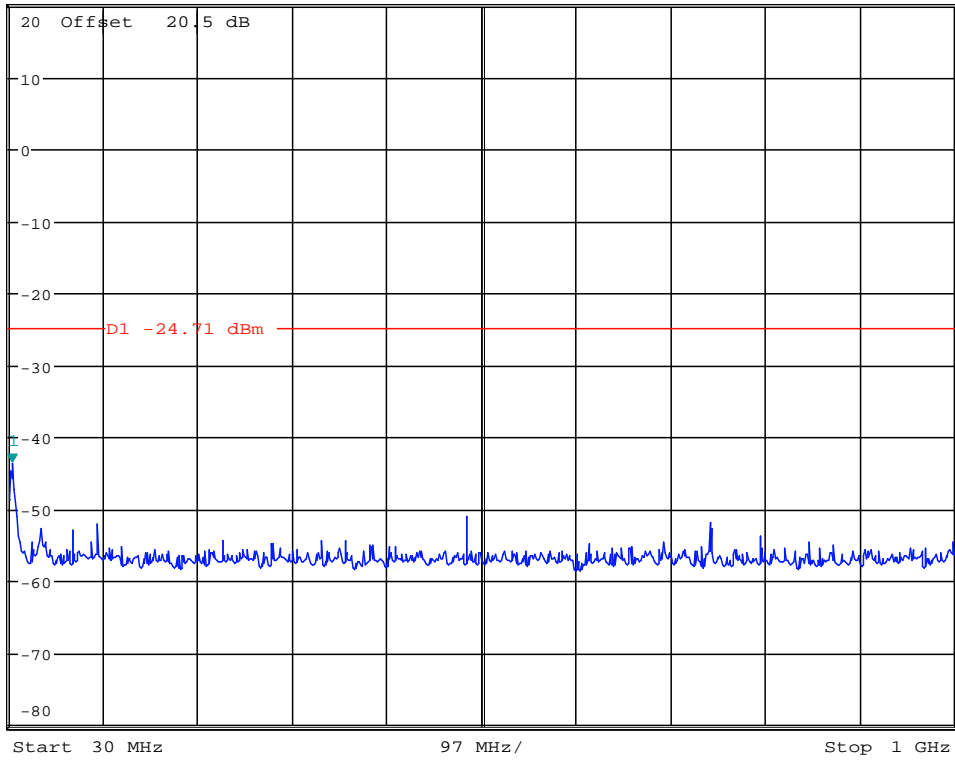

Ref 20 dBm *Att 10 dB *RBW 100 kHz Delta 2 [T1] -47.84 dB
*VBW 300 kHz 6.884615385 GHz
SWT 2.4 s

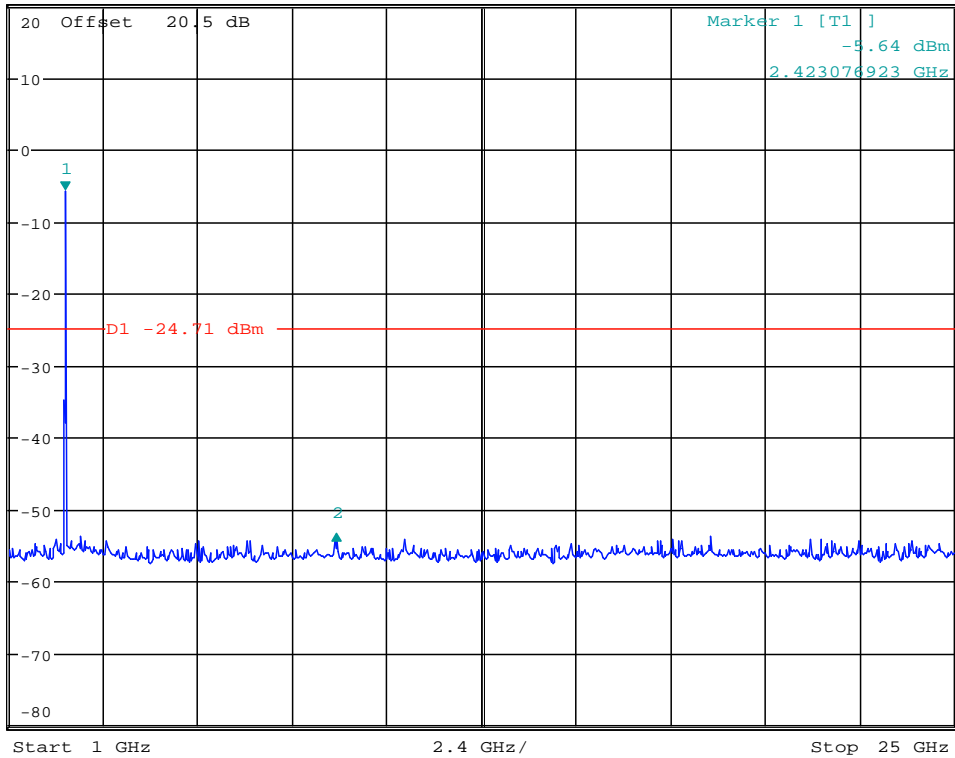

Chain 3 11n HT20 CH 11



Ref 20 dBm *Att 10 dB *RBW 100 kHz Marker 2 [T1]
*VBW 300 kHz -32.06 dBm
SWT 15 ms 2.483500000 GHz

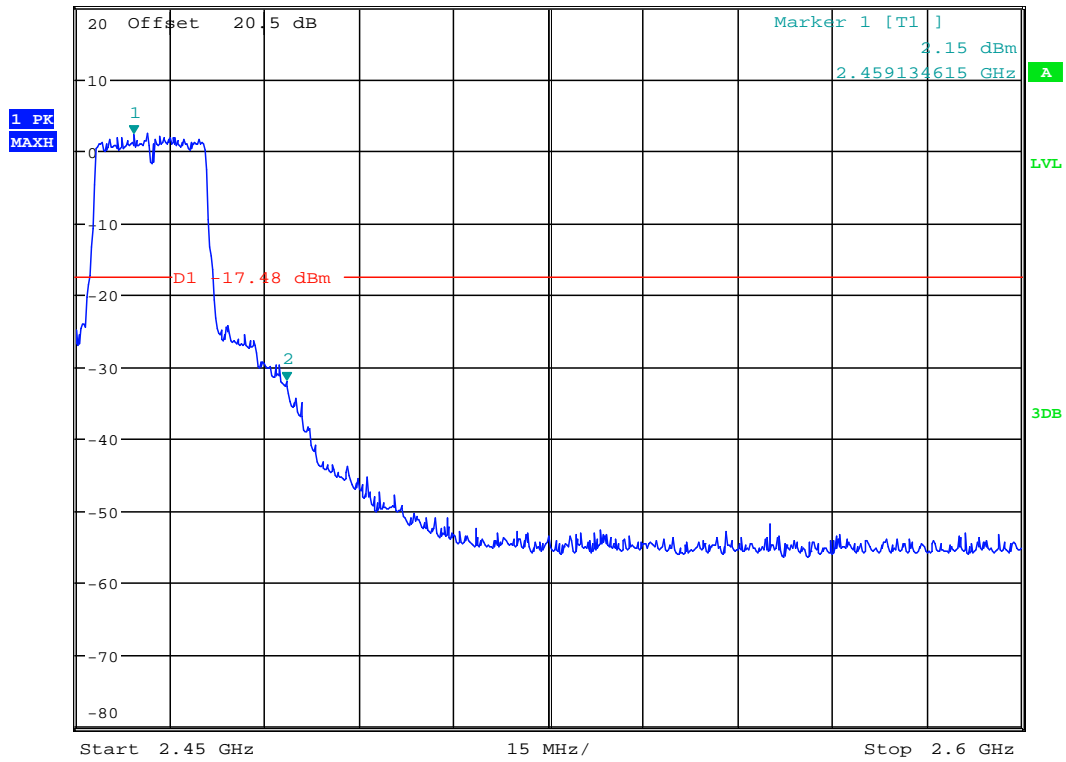

Ref 20 dBm *Att 10 dB *RBW 100 kHz Marker 1 [T1]
*VBW 300 kHz 2.52 dBm
SWT 20 ms 2.459115385 GHz

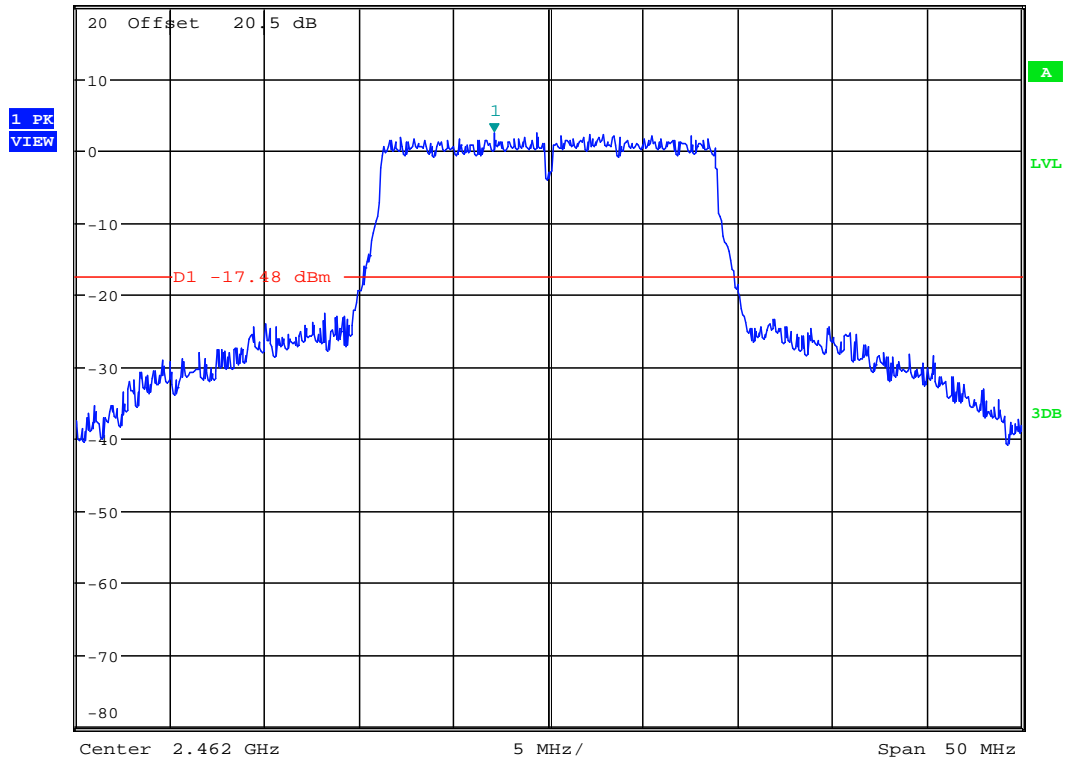

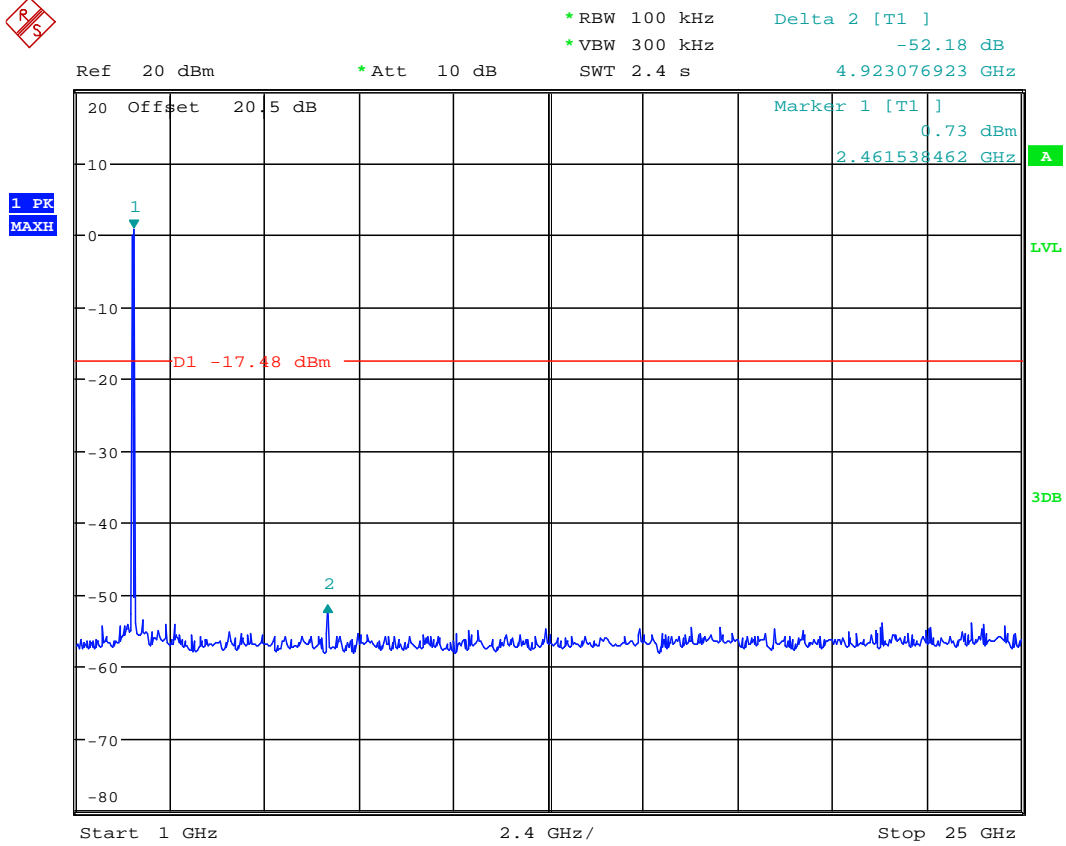
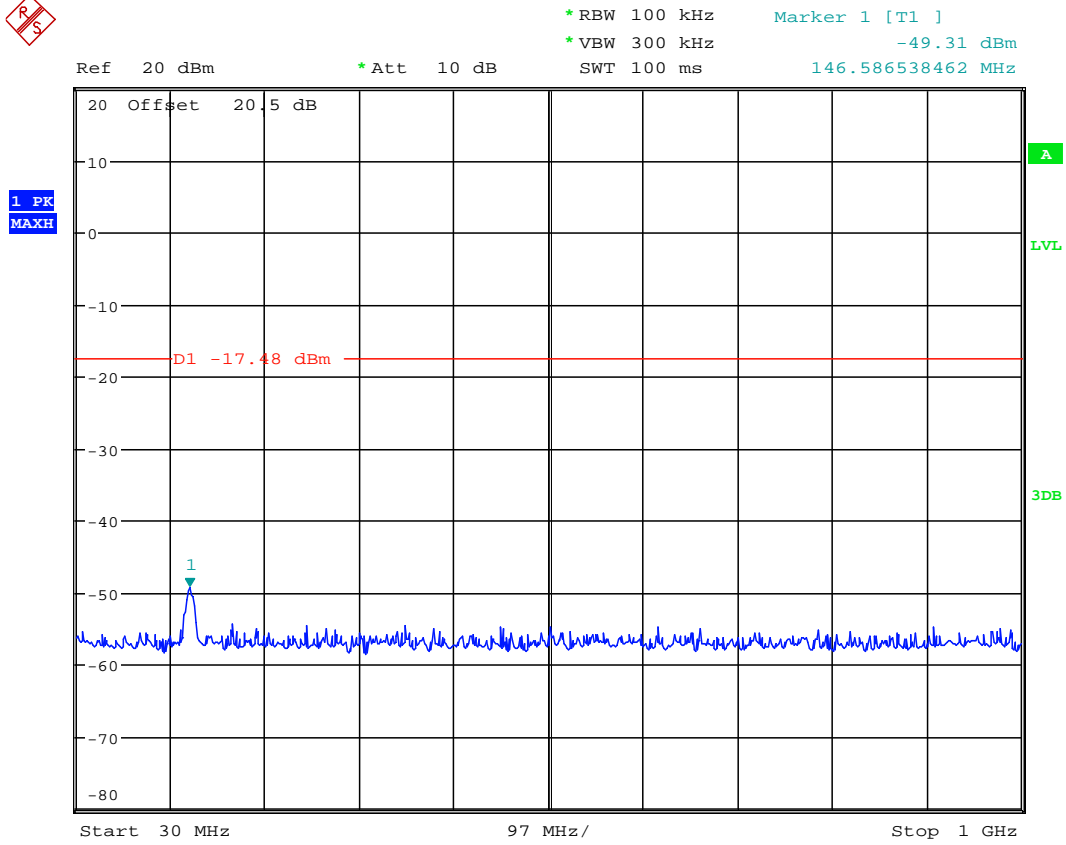

Chain 3 11n HT40 CH 3



Ref 20 dBm *Att 10 dB *RBW 100 kHz Marker 2 [T1]
*VBW 300 kHz -43.88 dBm
SWT 15 ms 2.483500000 GHz

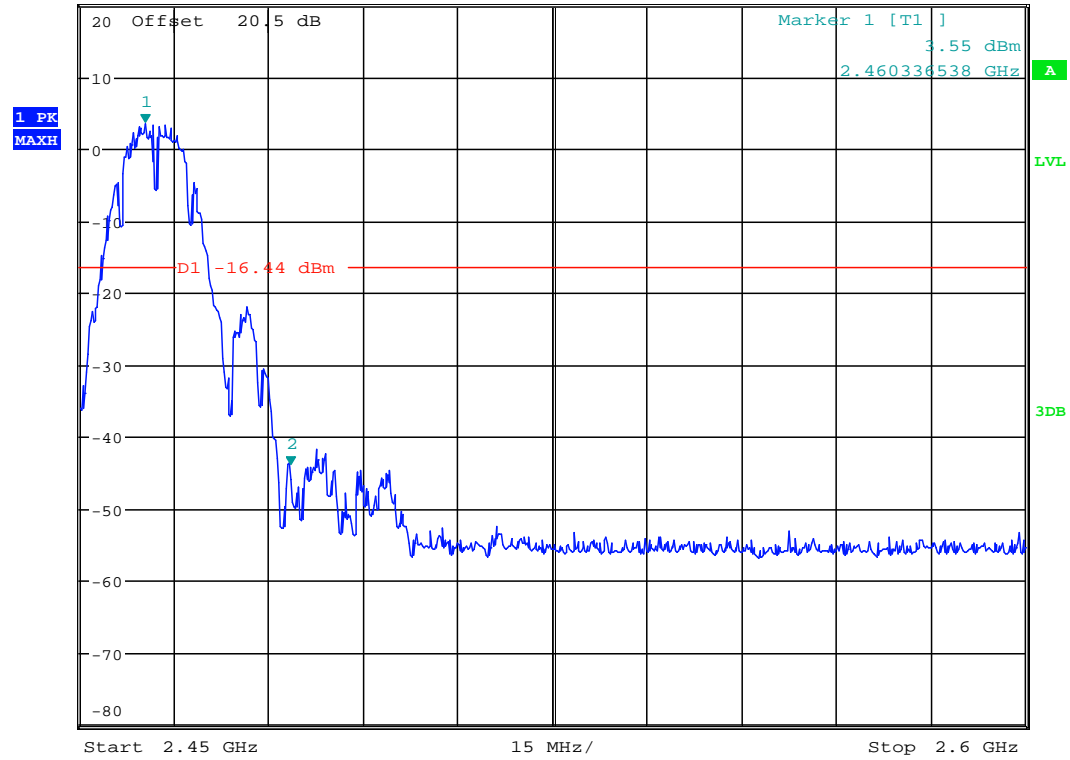

Ref 20 dBm *Att 10 dB *RBW 100 kHz Marker 1 [T1]
*VBW 300 kHz 3.56 dBm
SWT 20 ms 2.460557692 GHz

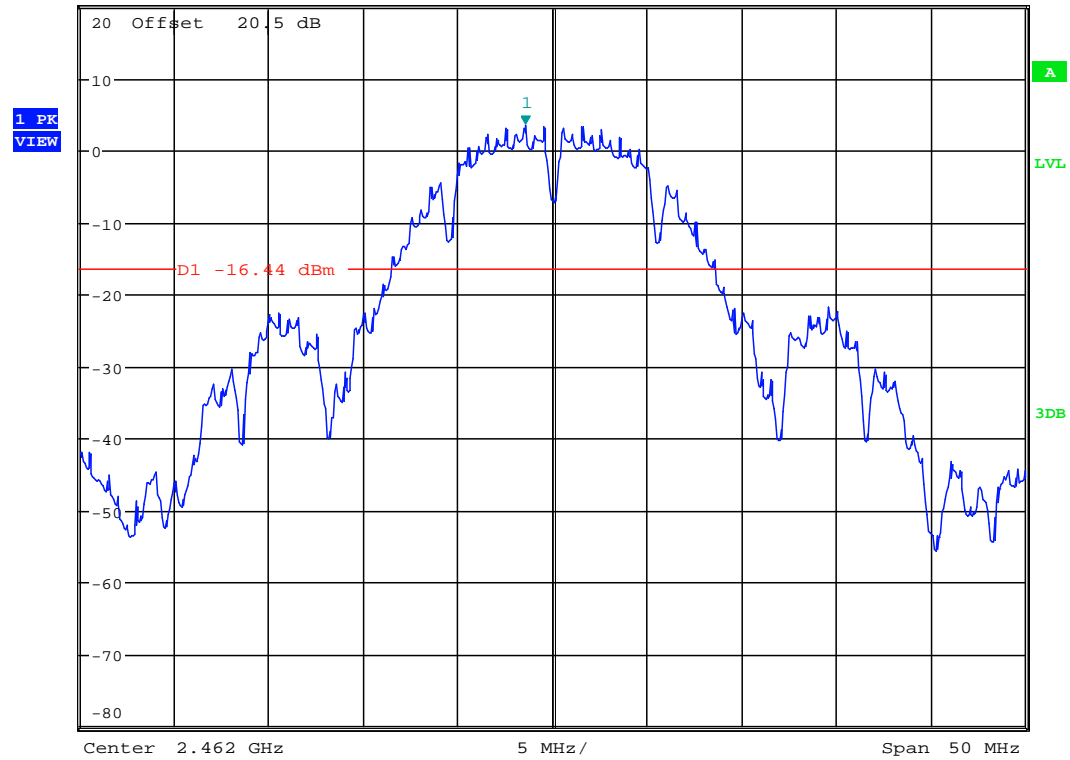

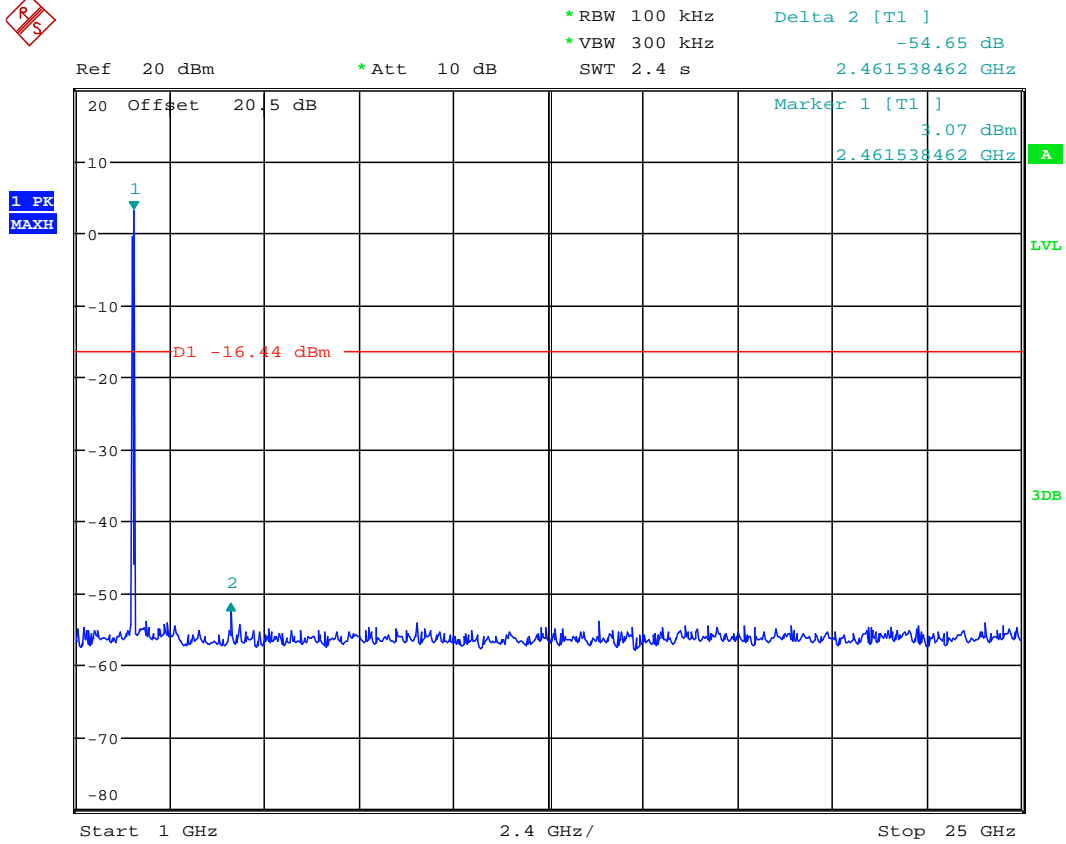
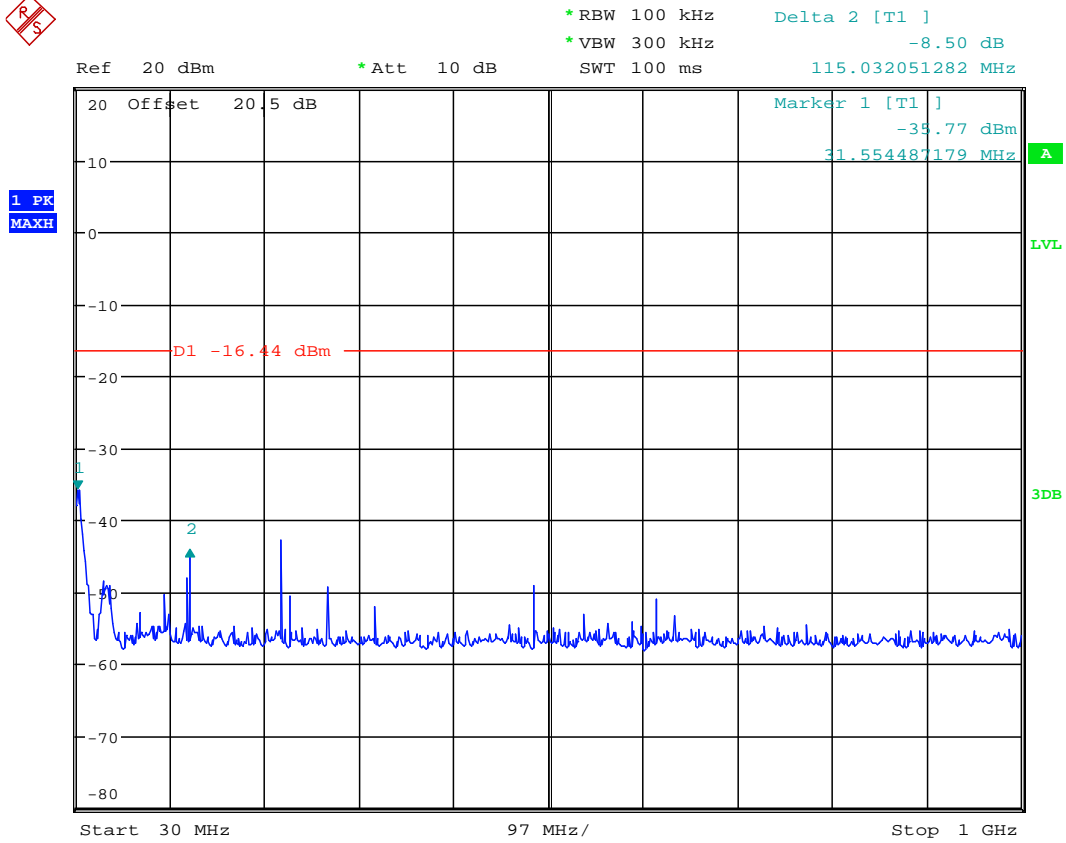

Chain 3 11n HT40 CH 6



Ref 20 dBm *Att 10 dB *RBW 100 kHz Marker 1 [T1]
*VBW 300 kHz 5.92 dBm
SWT 20 ms 2.418891026 GHz

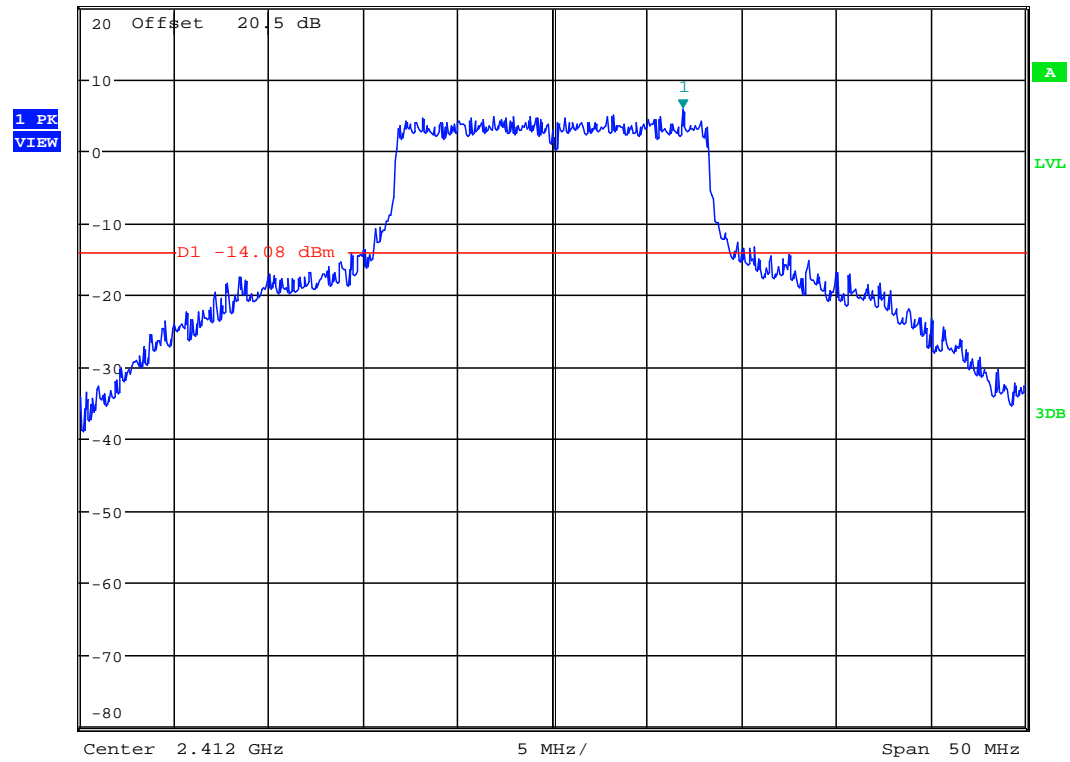

Ref 20 dBm *Att 10 dB *RBW 100 kHz Delta 2 [T1]
*VBW 300 kHz -58.53 dB
SWT 2.4 s 5.500000000 GHz

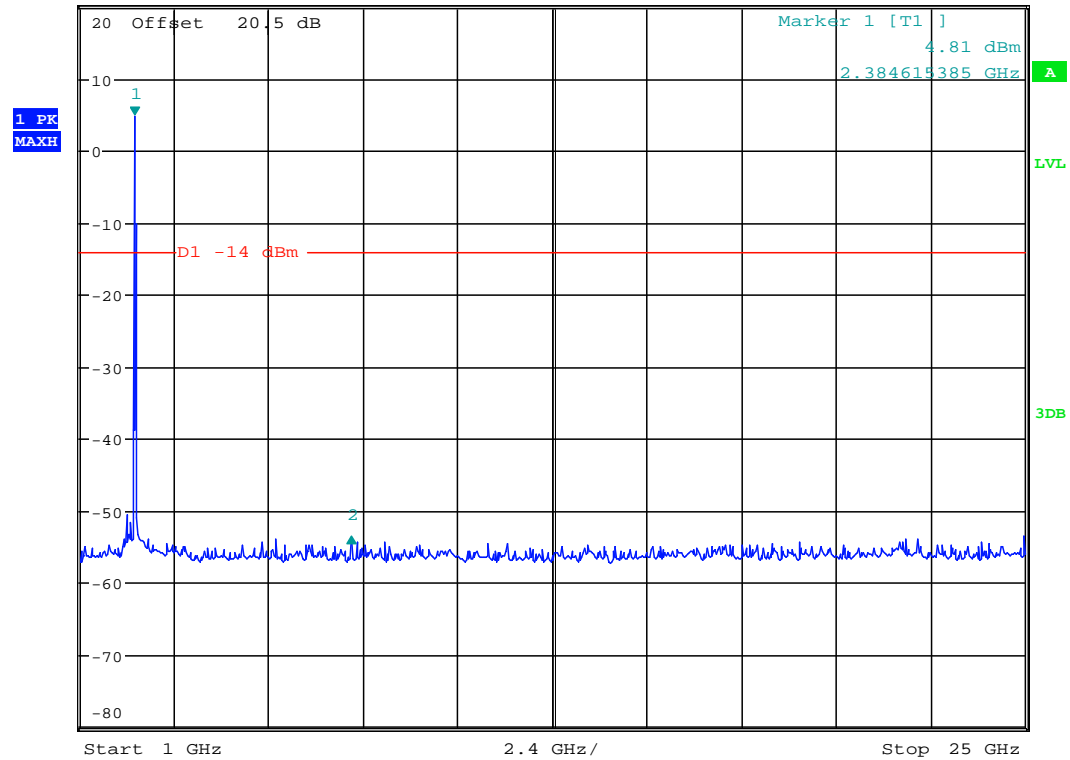

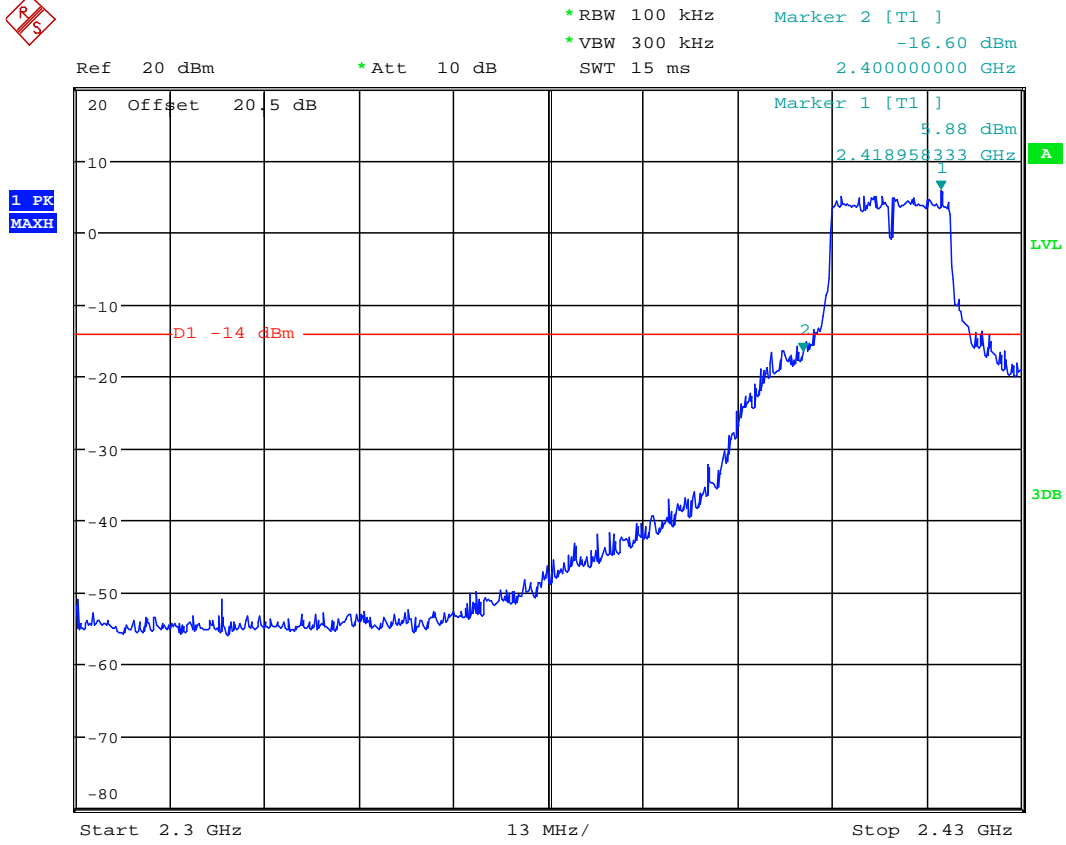

Chain 3 11n HT40 CH 9

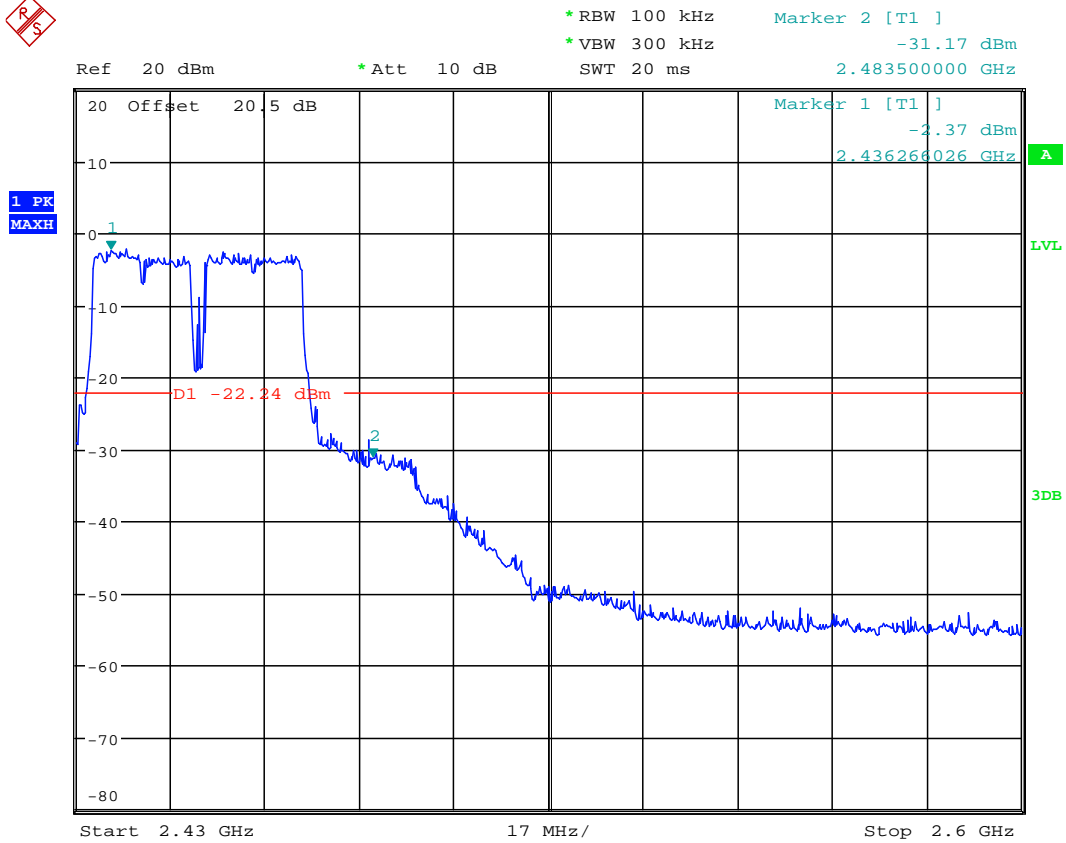

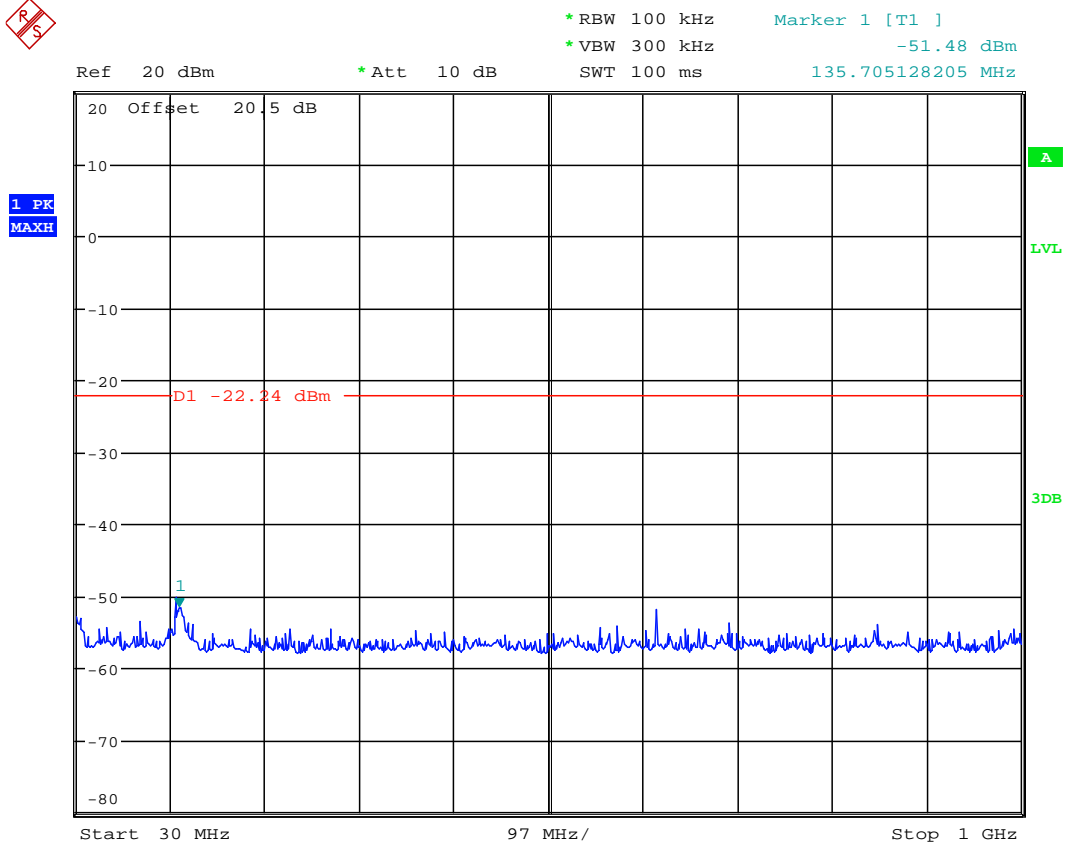
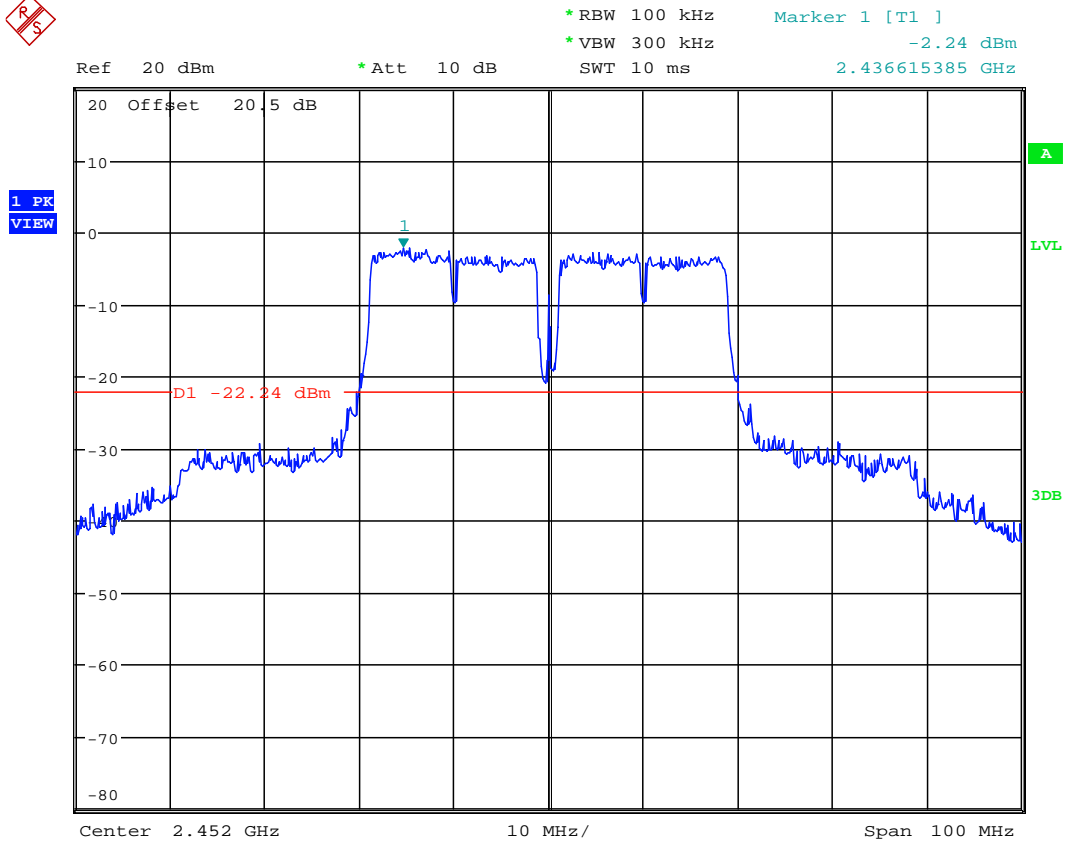

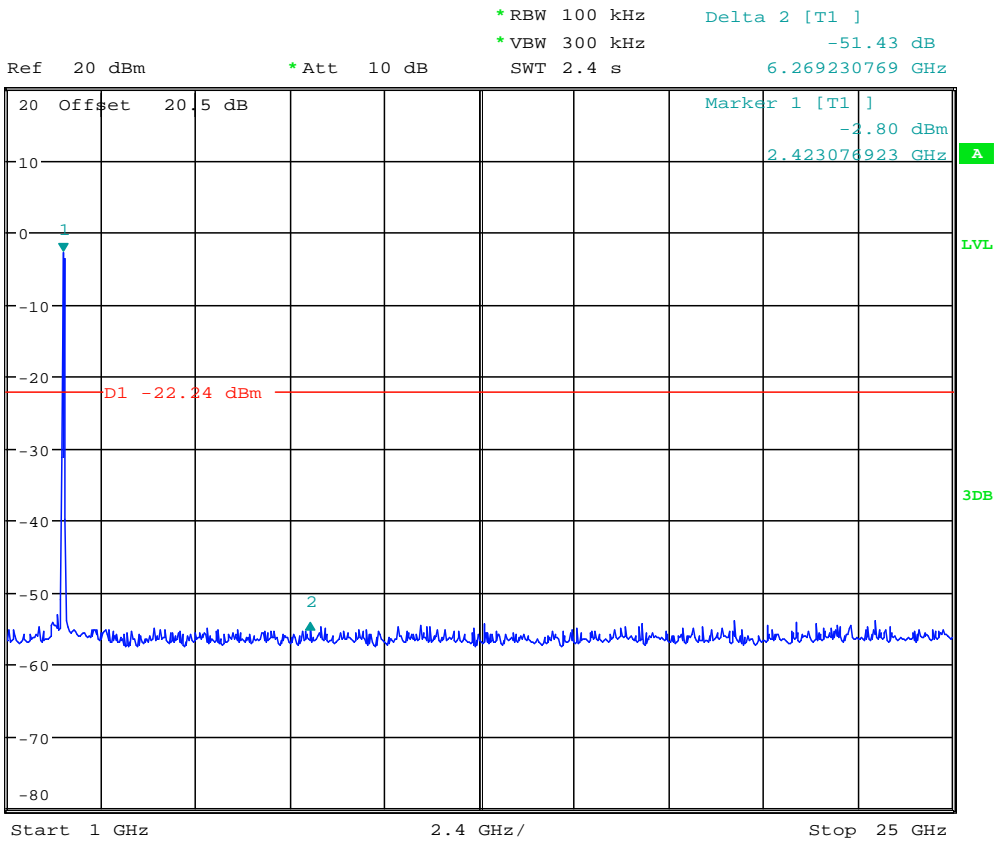

Chain 4 11b CH 1

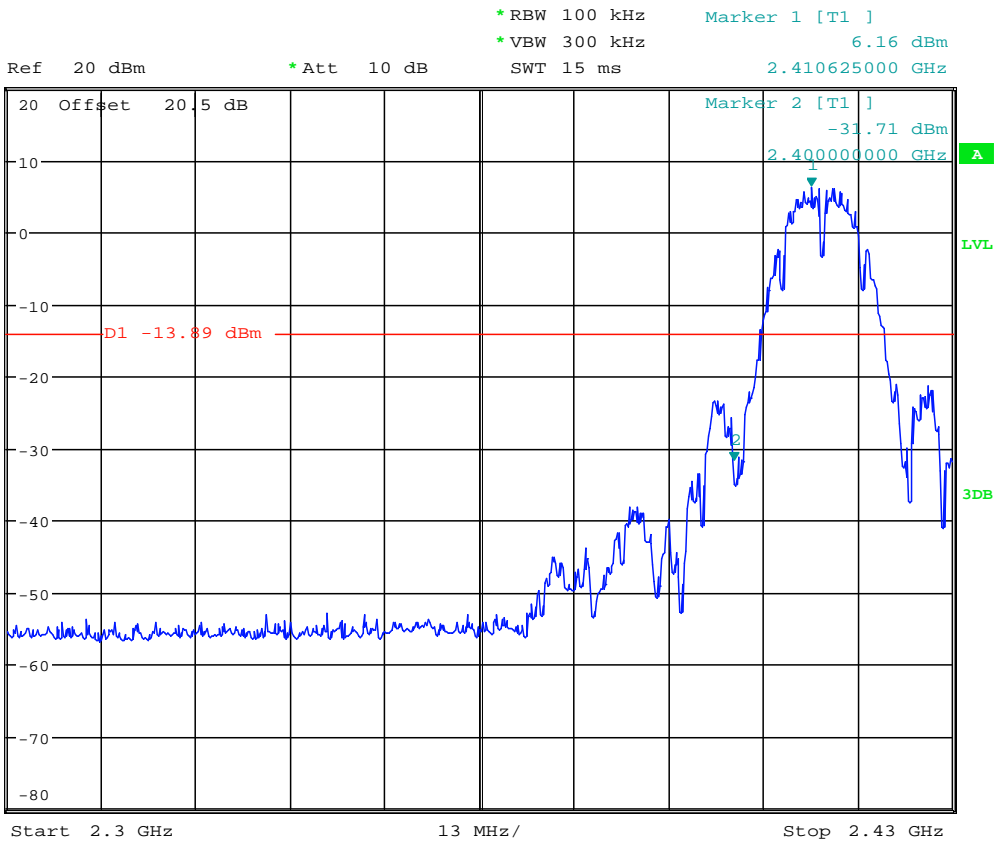

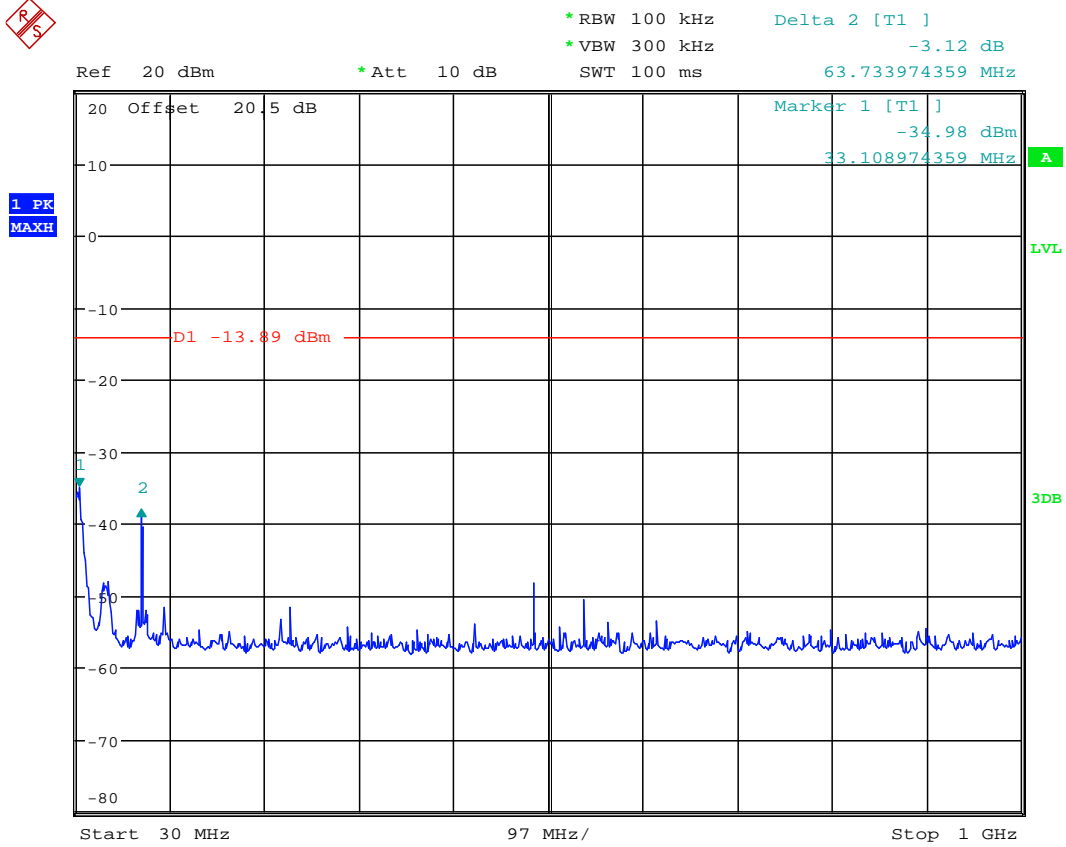

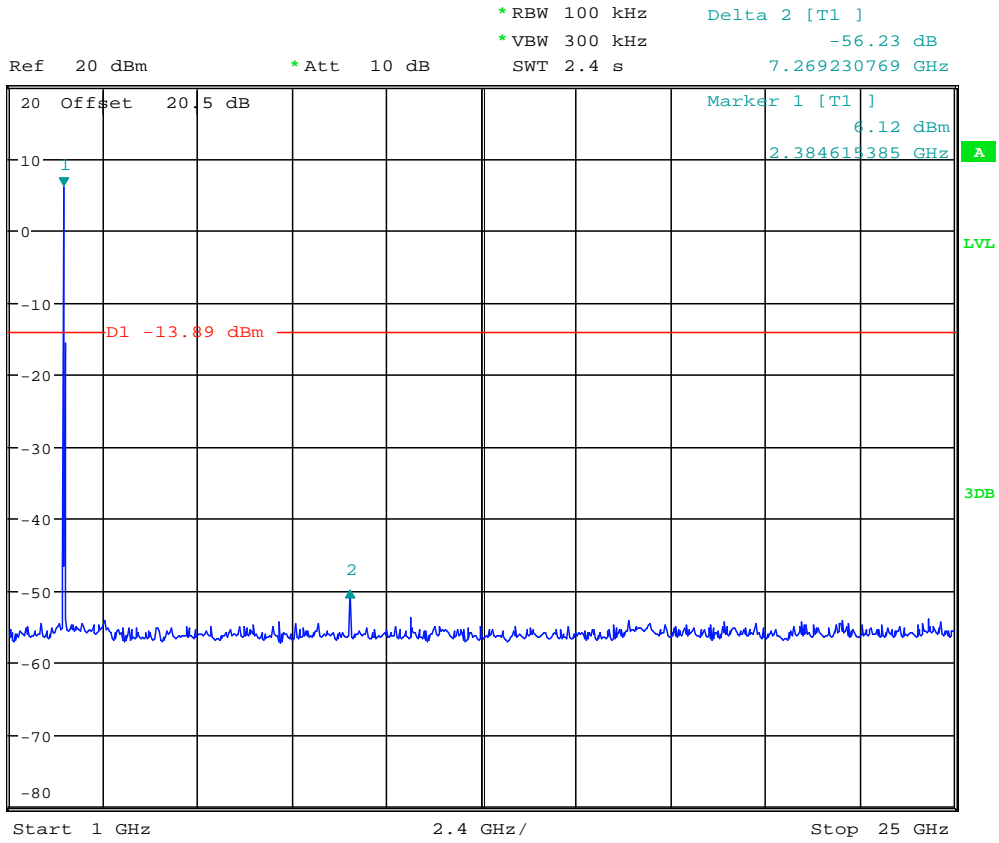

Chain 4 11b CH 6

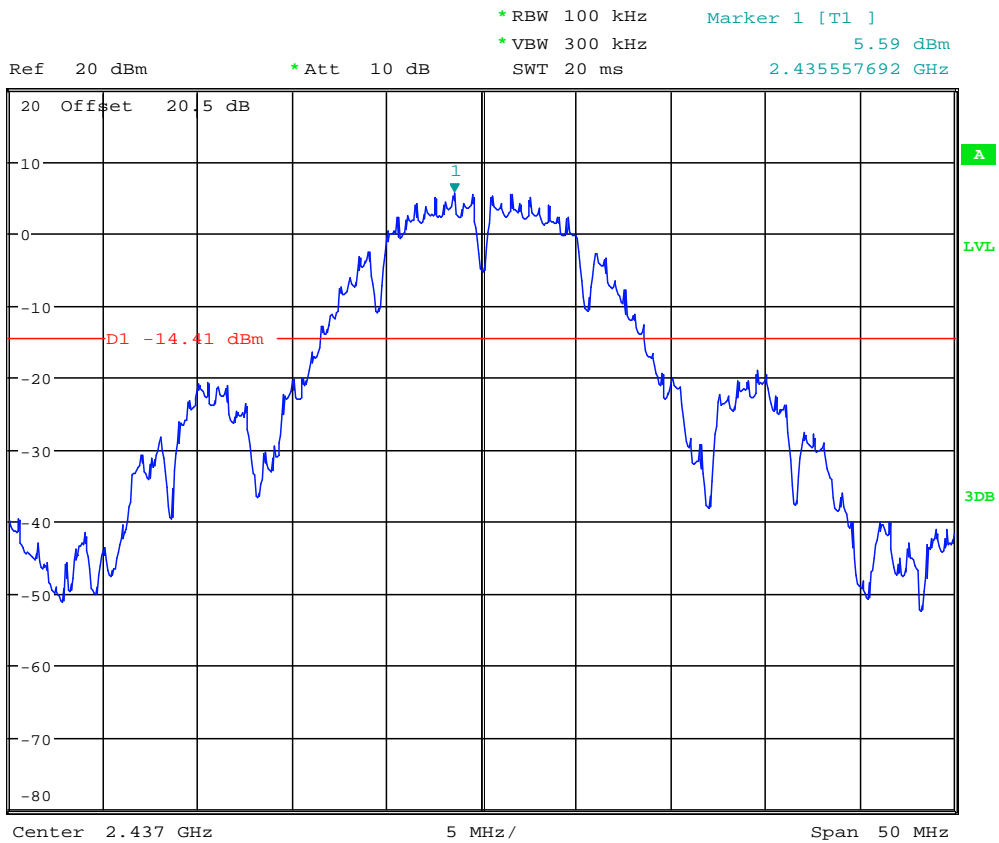

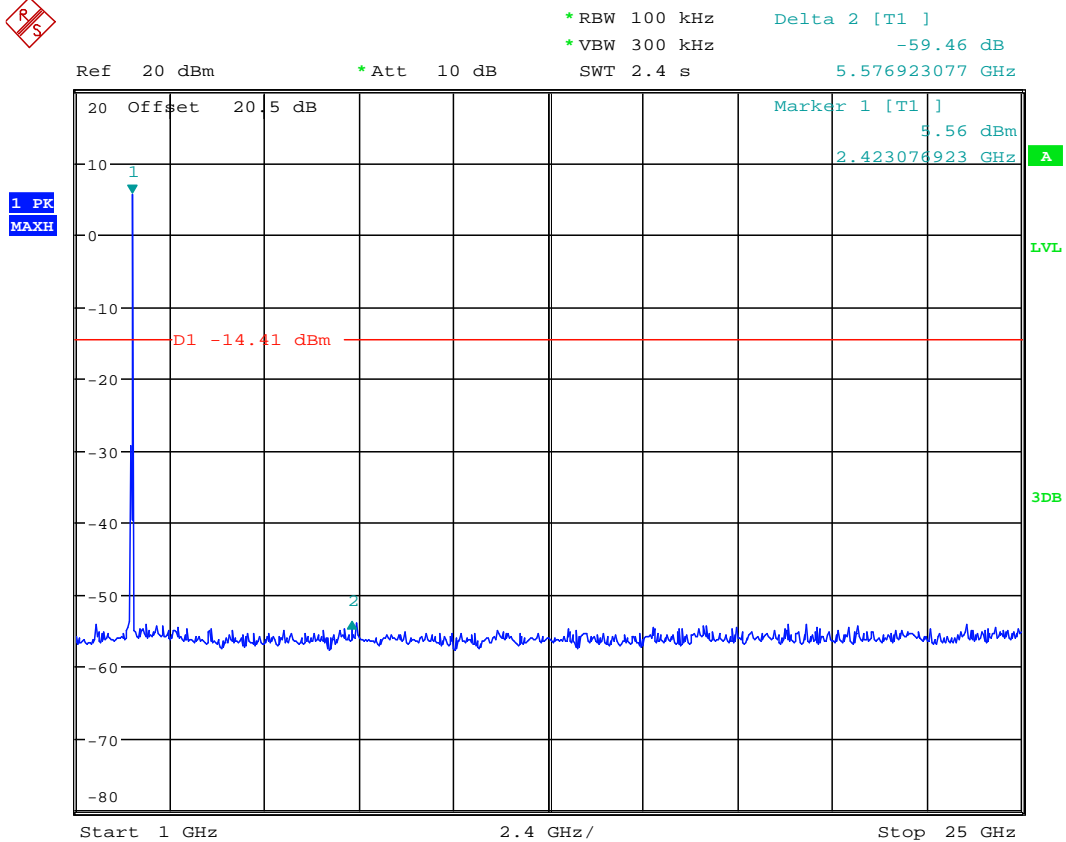
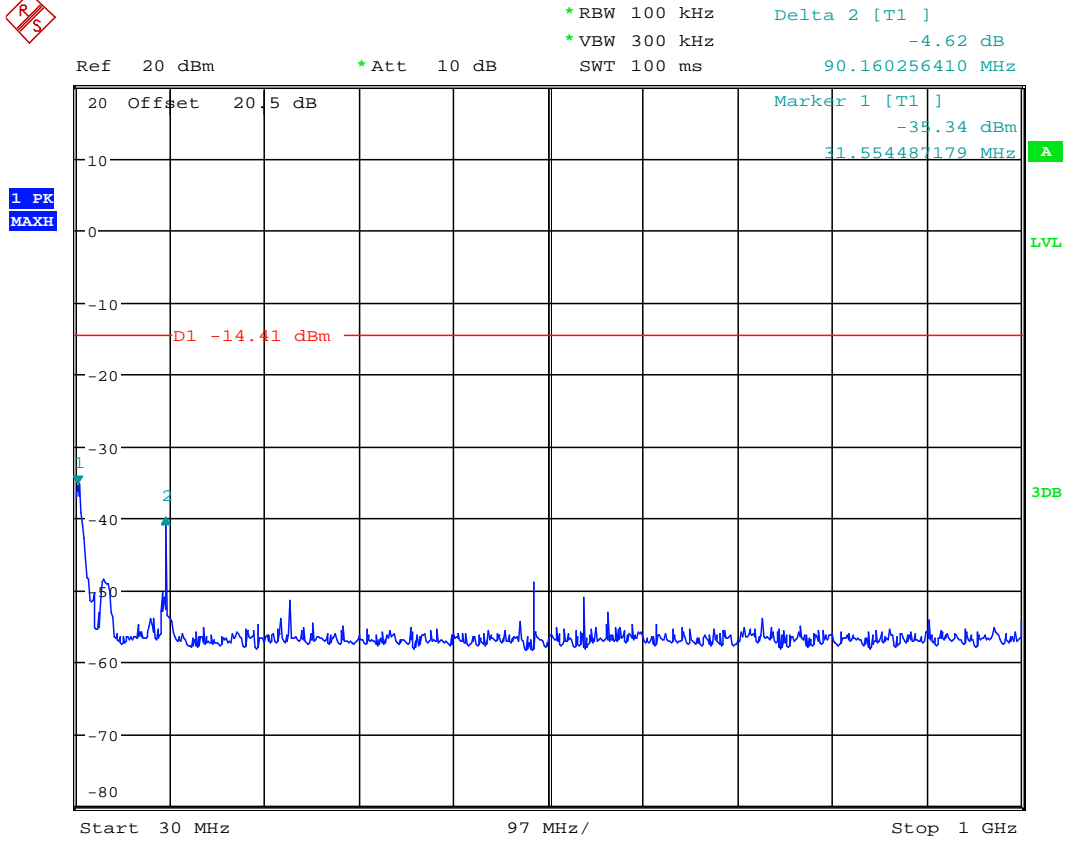

Chain 4 11b CH 11



Ref 20 dBm *Att 10 dB *RBW 100 kHz Marker 2 [T1]
*VBW 300 kHz -41.90 dBm
SWT 15 ms 2.48350000 GHz



Ref 20 dBm *Att 10 dB *RBW 100 kHz Marker 1 [T1]
*VBW 300 kHz 4.39 dBm
SWT 20 ms 2.460557692 GHz

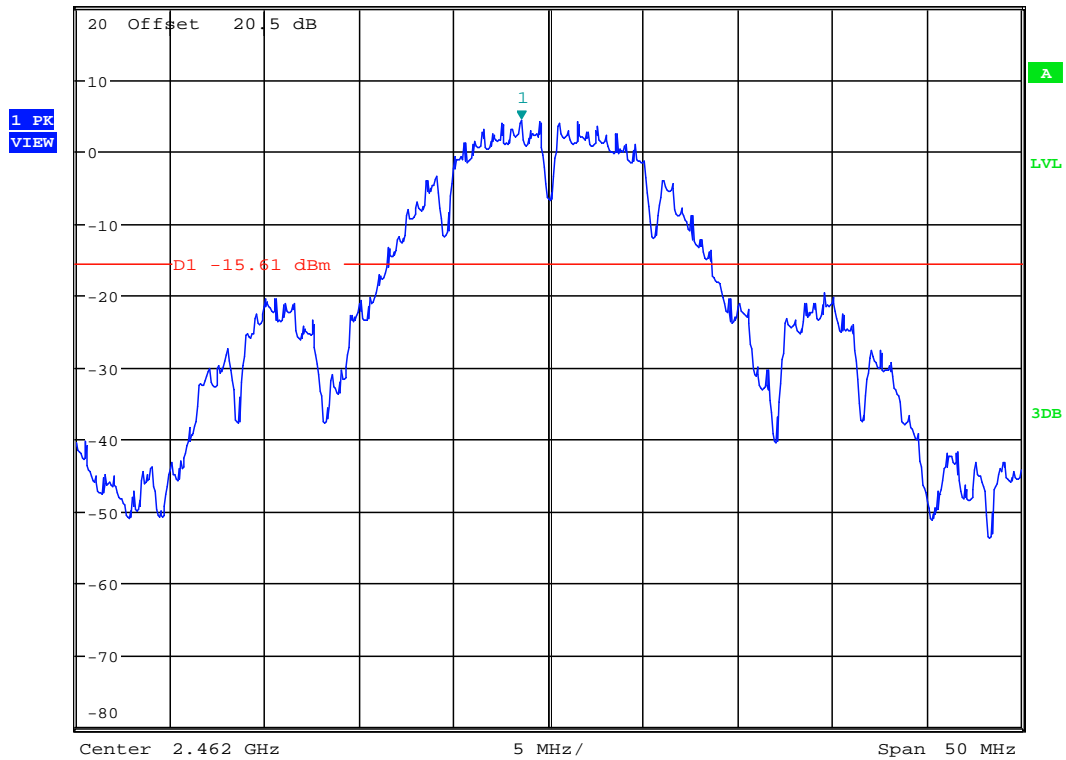

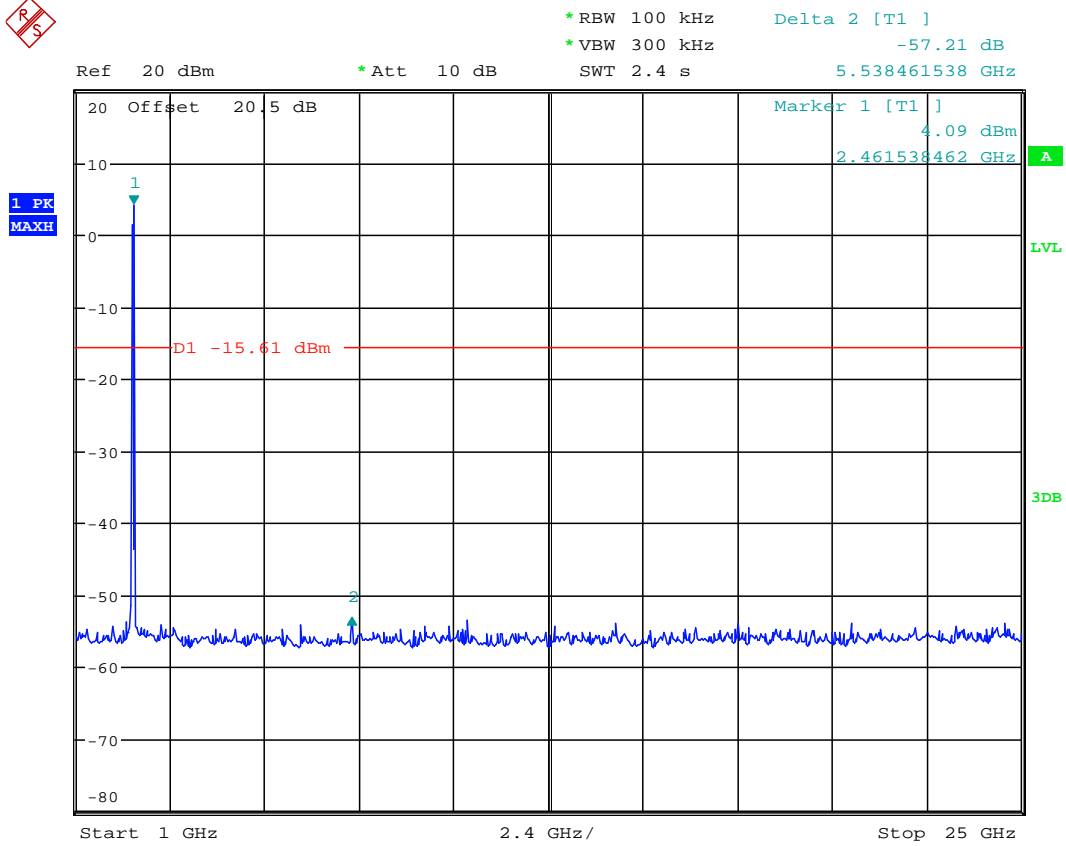
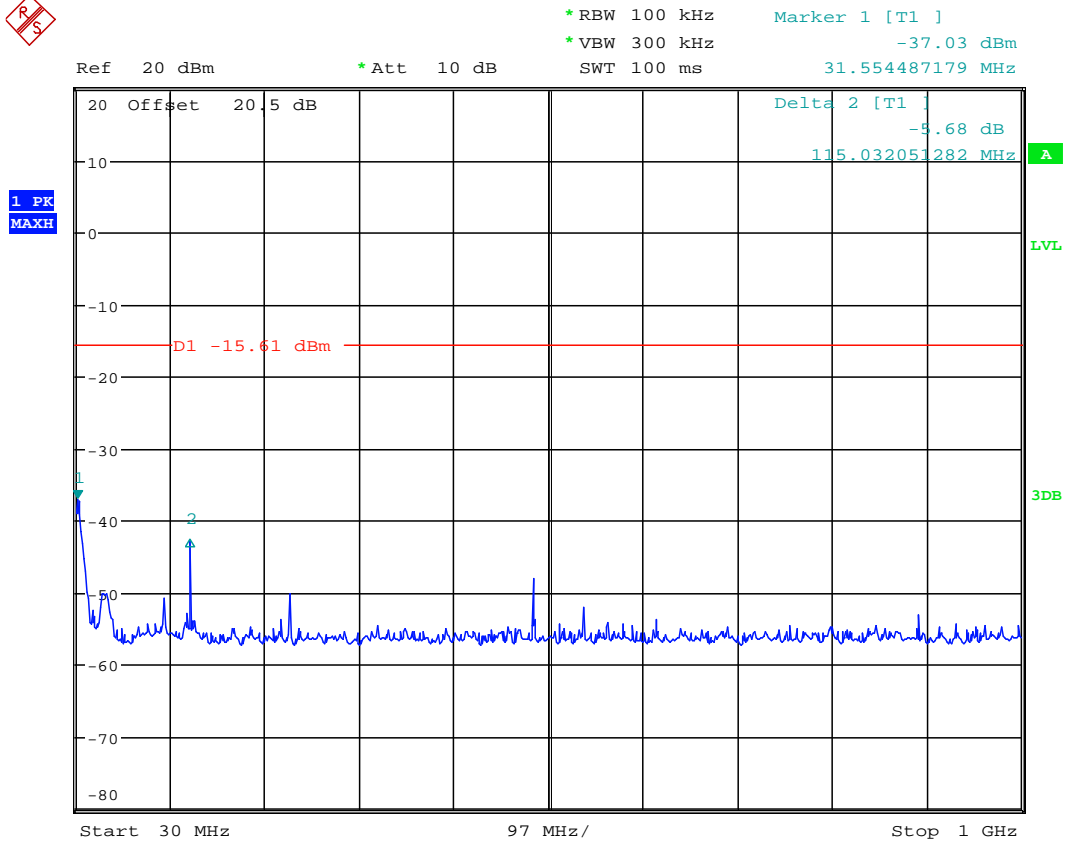

Chain 4 11g CH 1

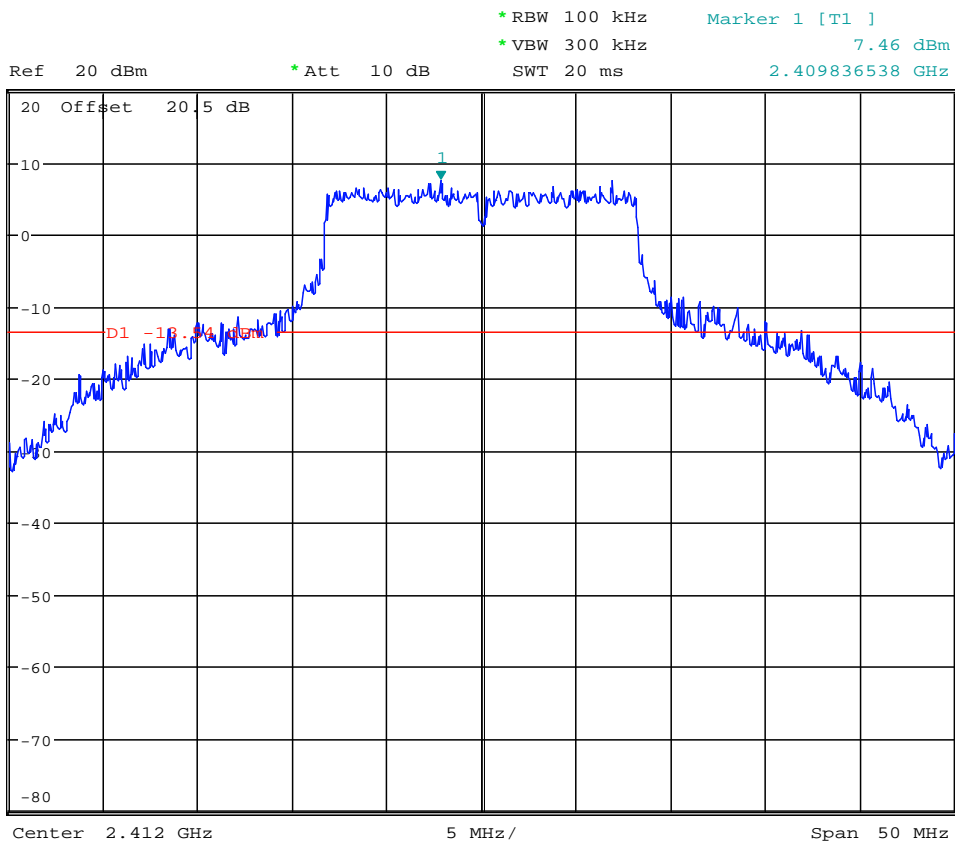
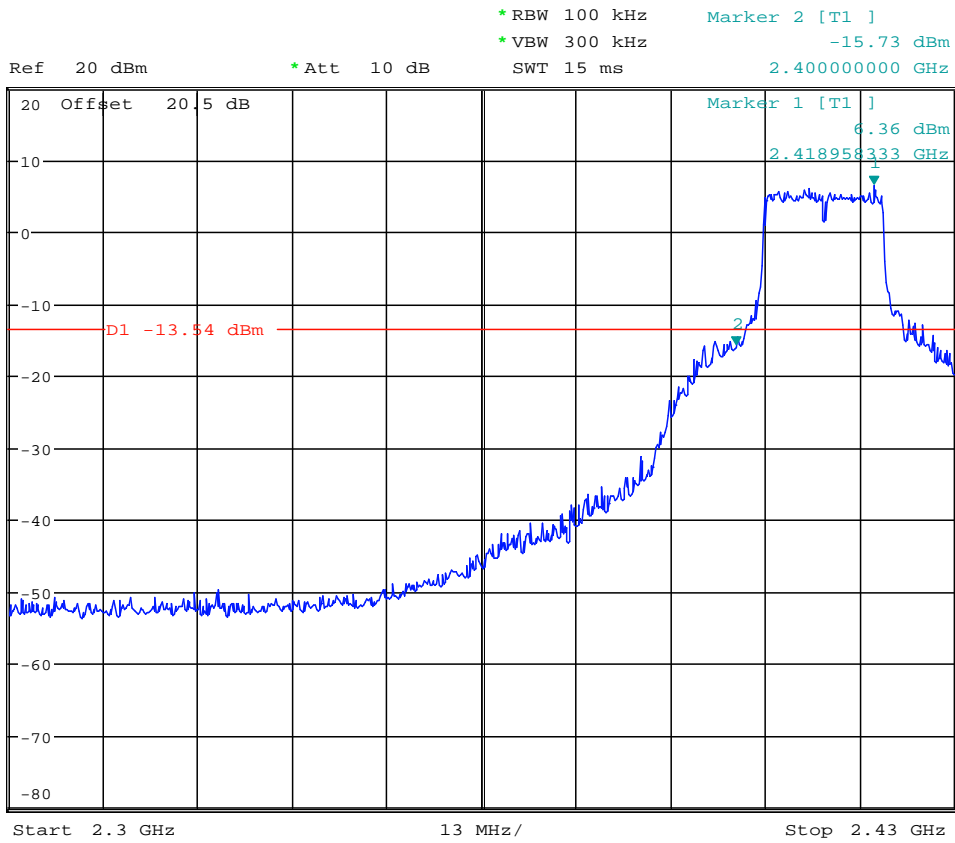



*RBW 100 kHz
*VBW 300 kHz
SWT 100 ms

Marker 1 [T1]
-39.70 dBm
99.951923077 MHz

Ref 20 dBm

*Att 10 dB

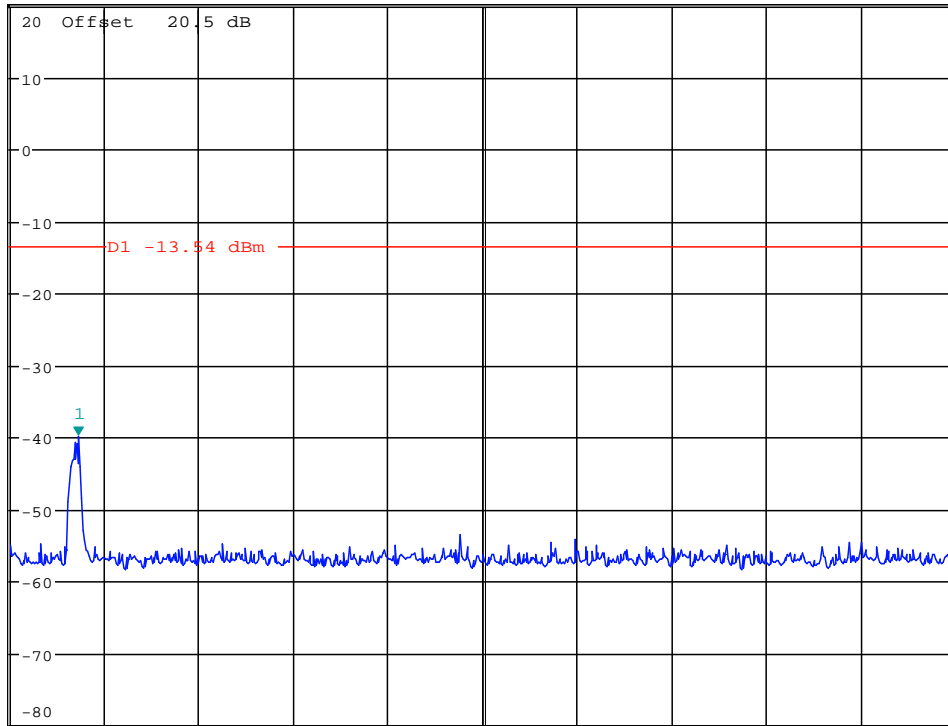

1 PK
MAXH

A
LVL
3DB

Start 30 MHz 97 MHz/ Stop 1 GHz



*RBW 100 kHz
*VBW 300 kHz
SWT 2.4 s

Delta 2 [T1]
-59.96 dB
9.038461538 GHz

Ref 20 dBm

*Att 10 dB

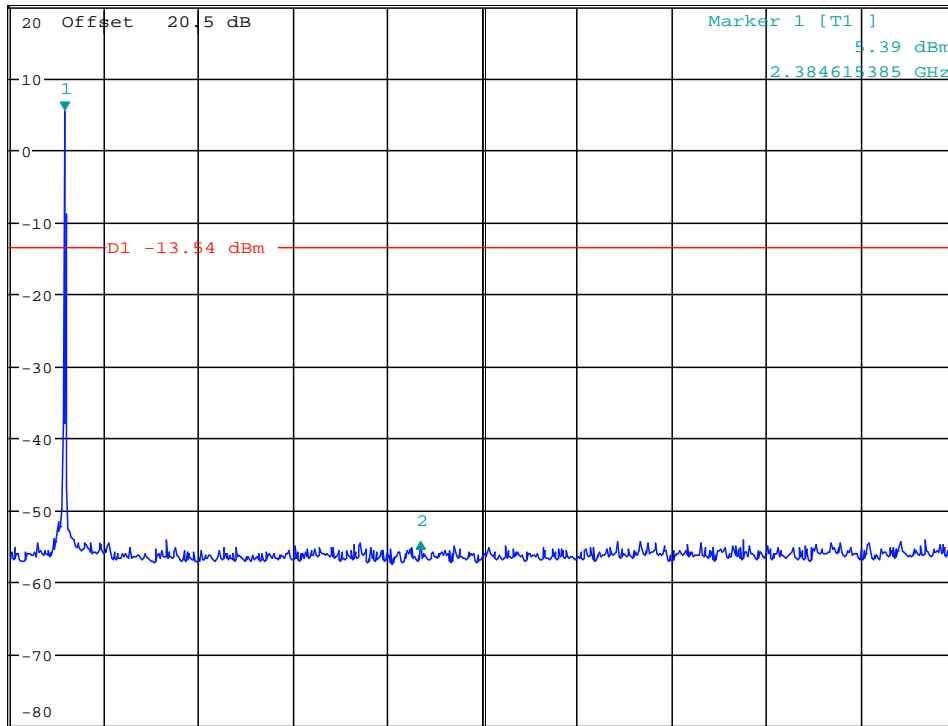

1 PK
MAXH

A
LVL
3DB

Start 1 GHz 2.4 GHz/ Stop 25 GHz

Chain 4 11g CH 6



Ref 20 dBm *Att 10 dB *RBW 100 kHz Marker 1 [T1]
*VBW 300 kHz 5.25 dBm
SWT 20 ms 2.434275641 GHz

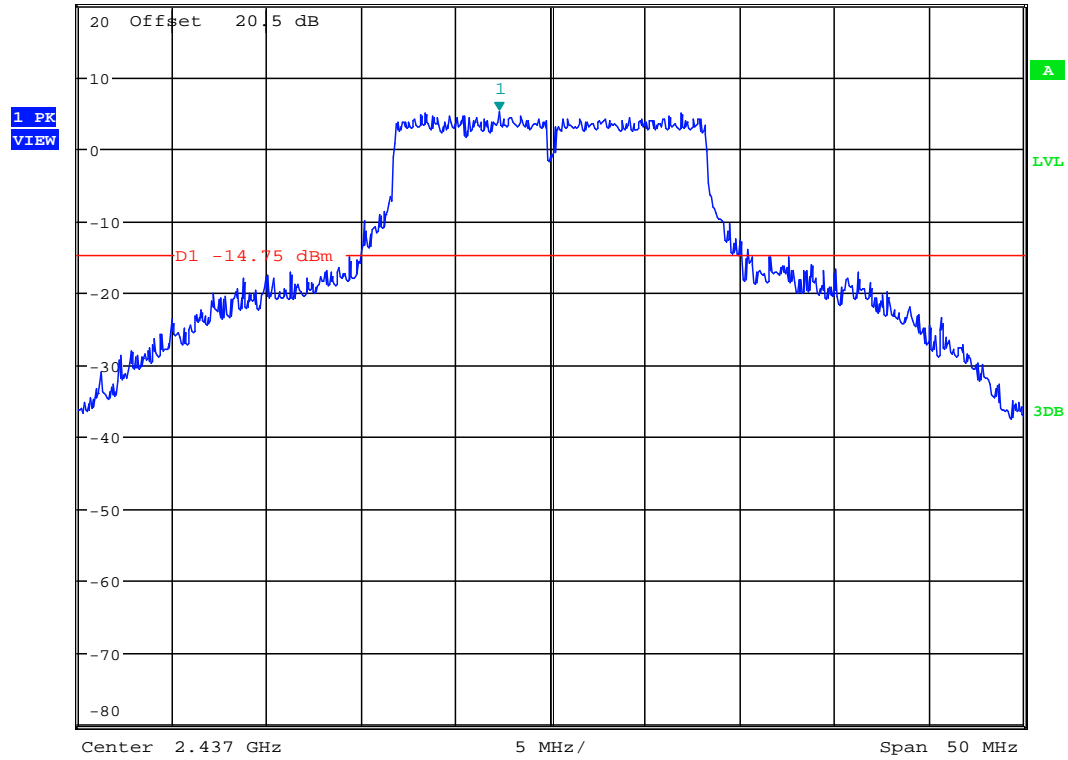

Ref 20 dBm *Att 10 dB *RBW 100 kHz Marker 1 [T1]
*VBW 300 kHz -43.64 dBm
SWT 100 ms 123.269230769 MHz

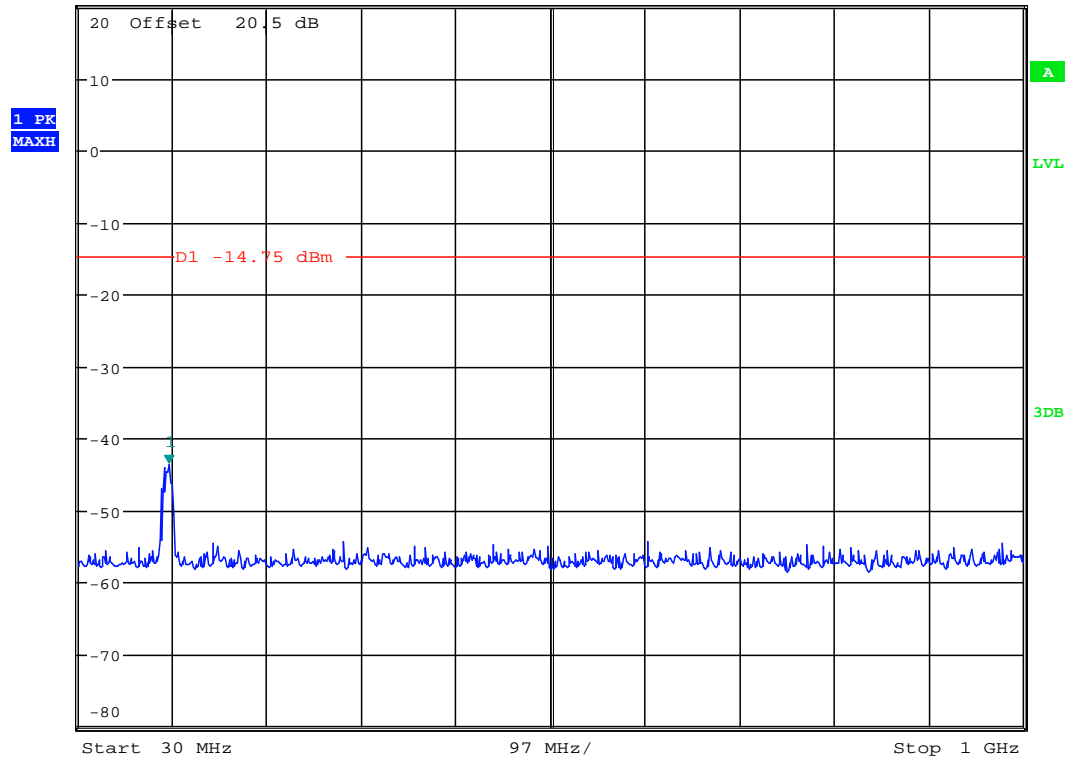

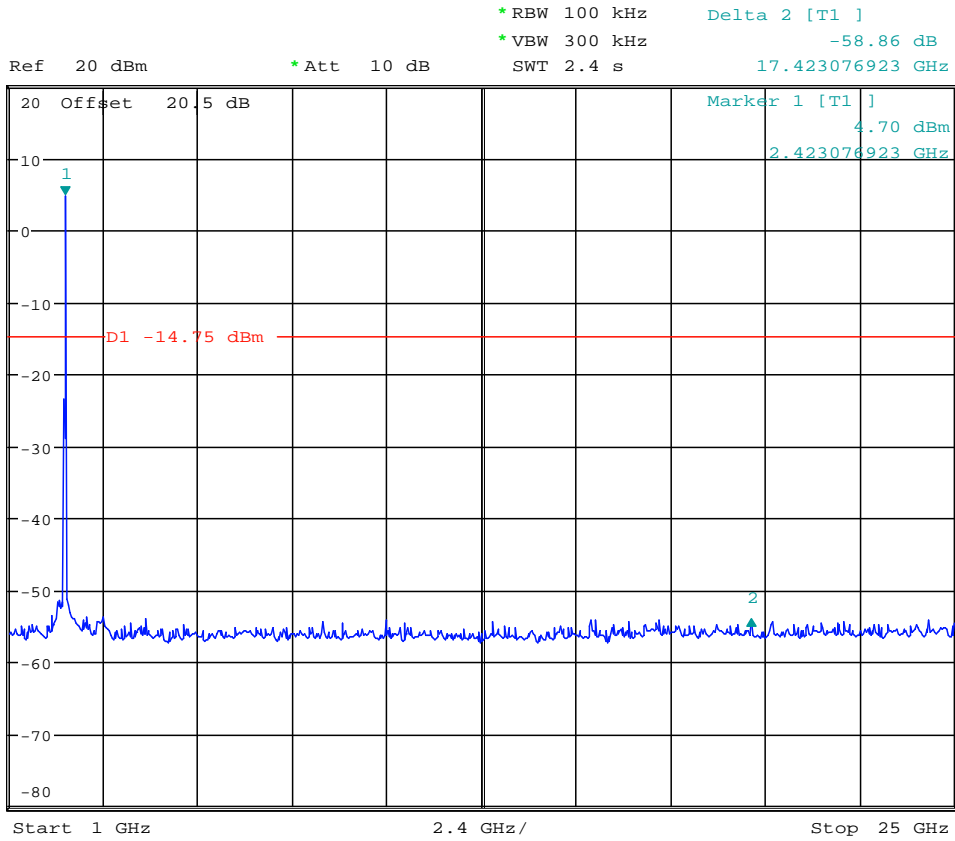

Chain 4 11g CH 11

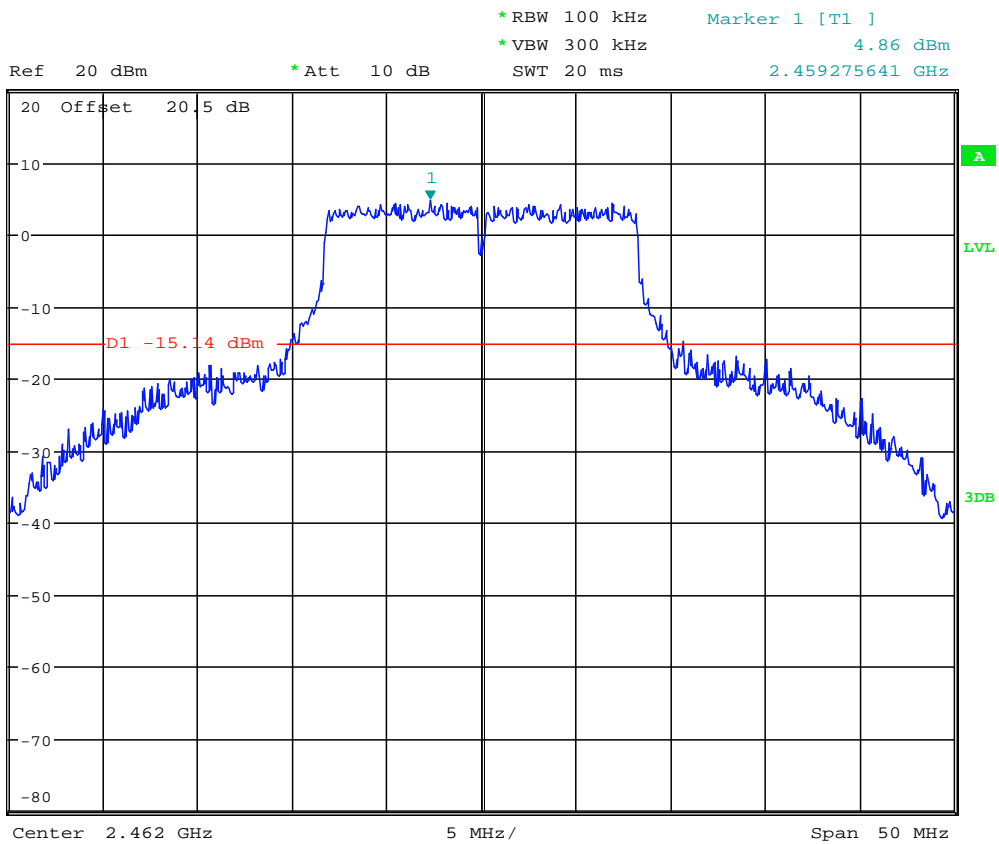

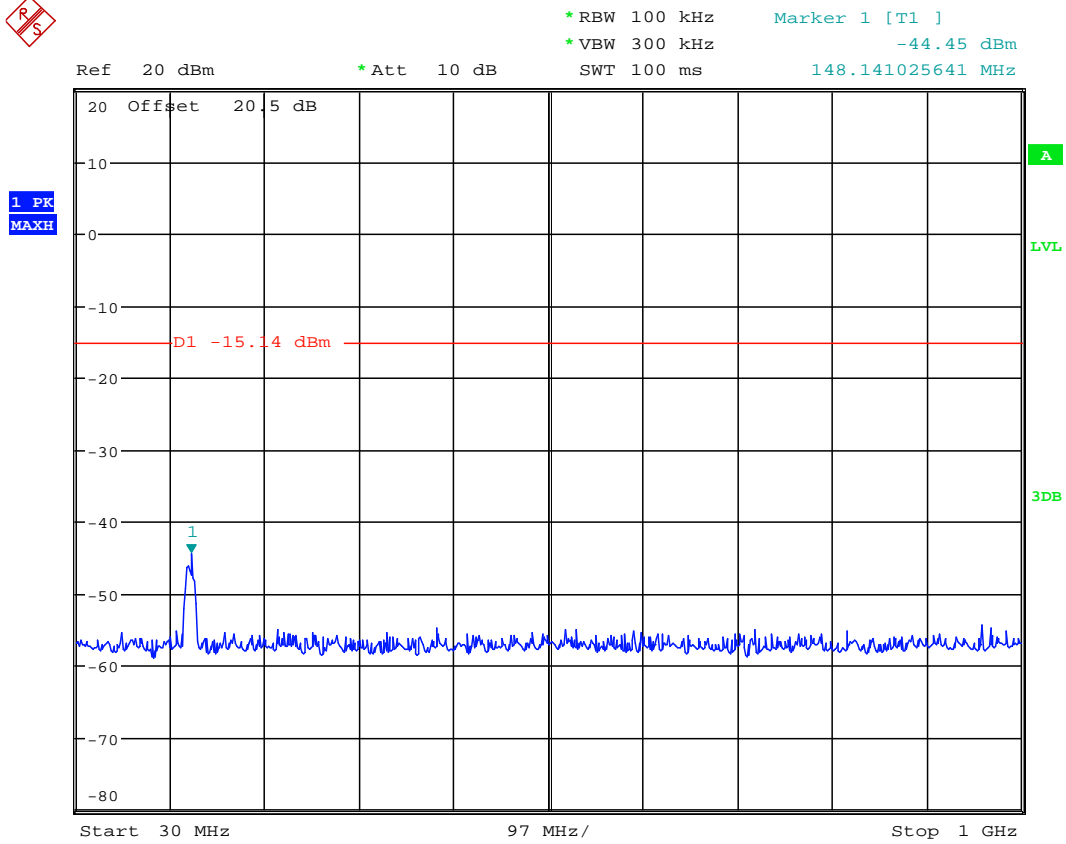
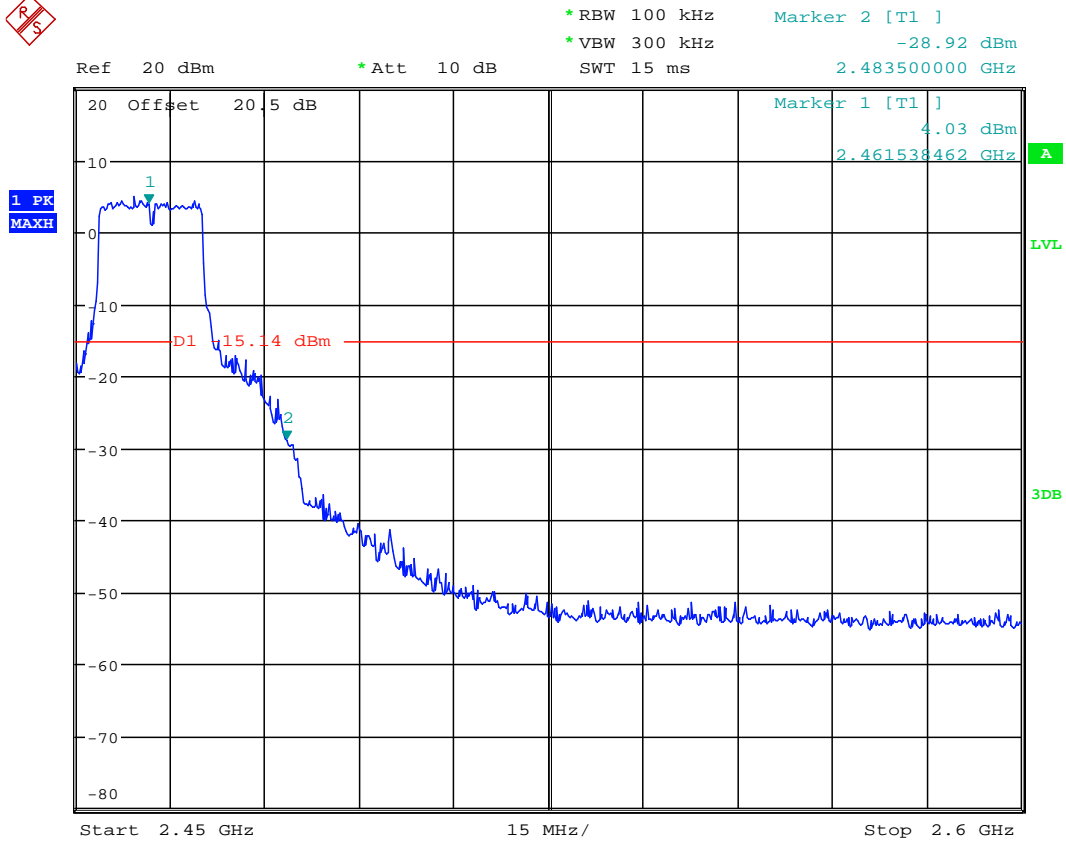

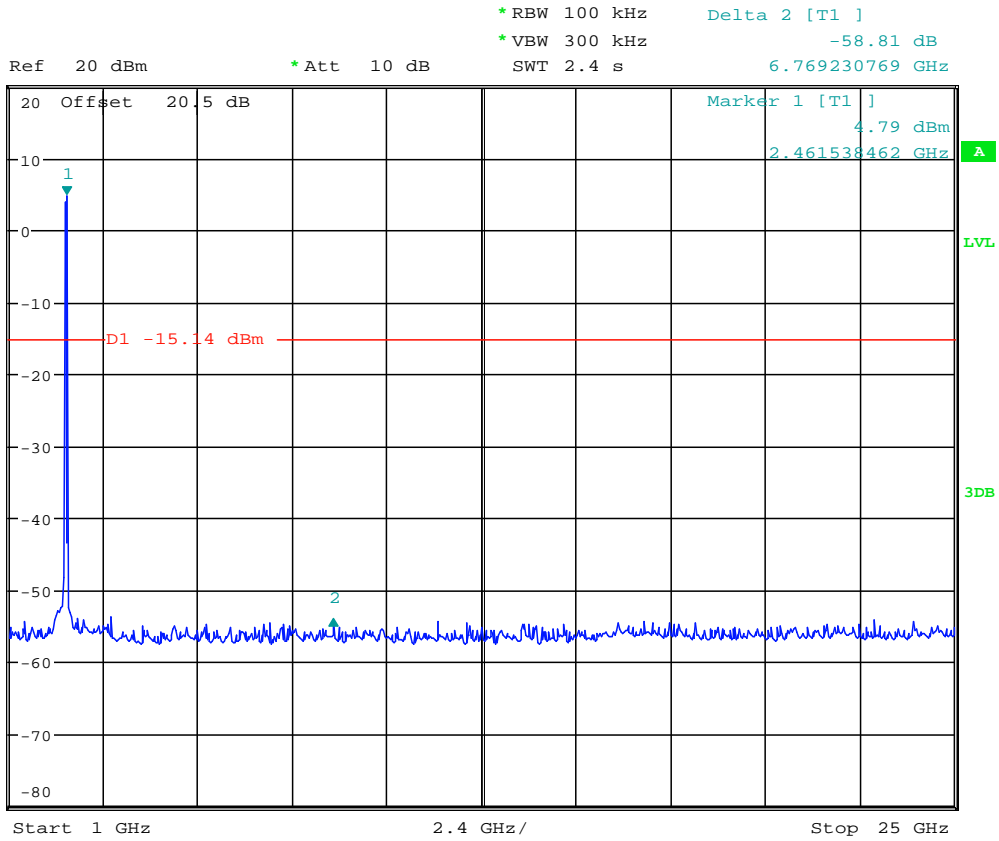

Chain 4 11n HT20 CH 1

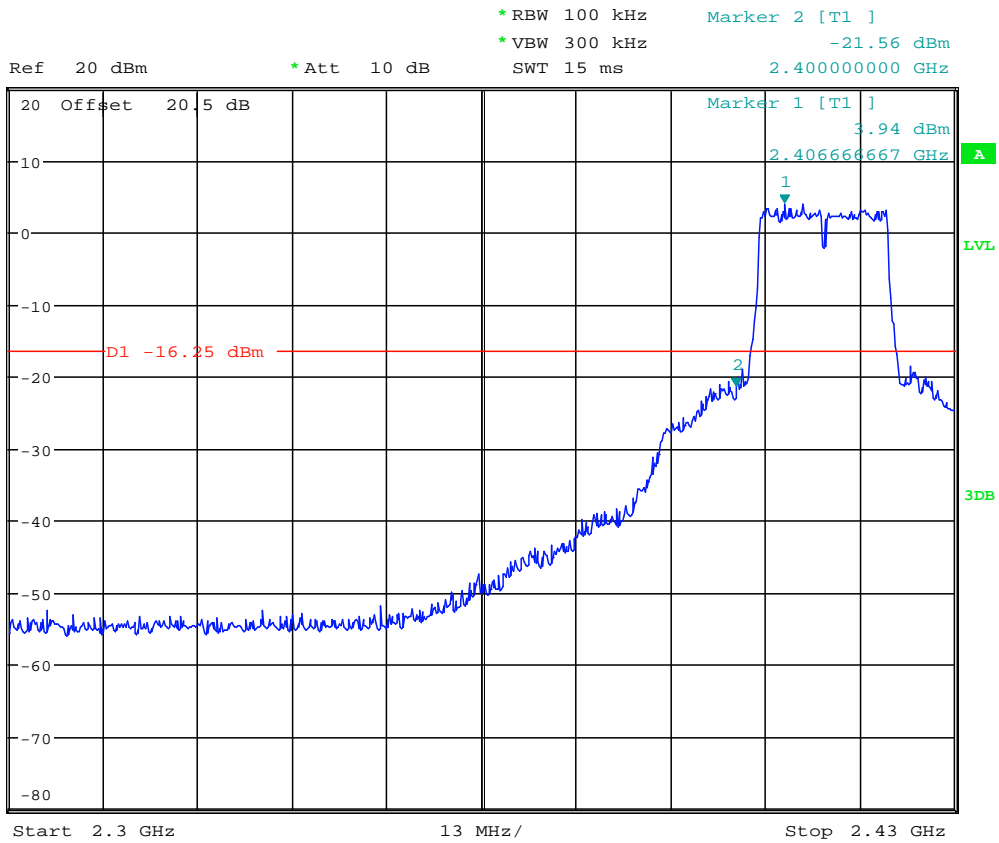

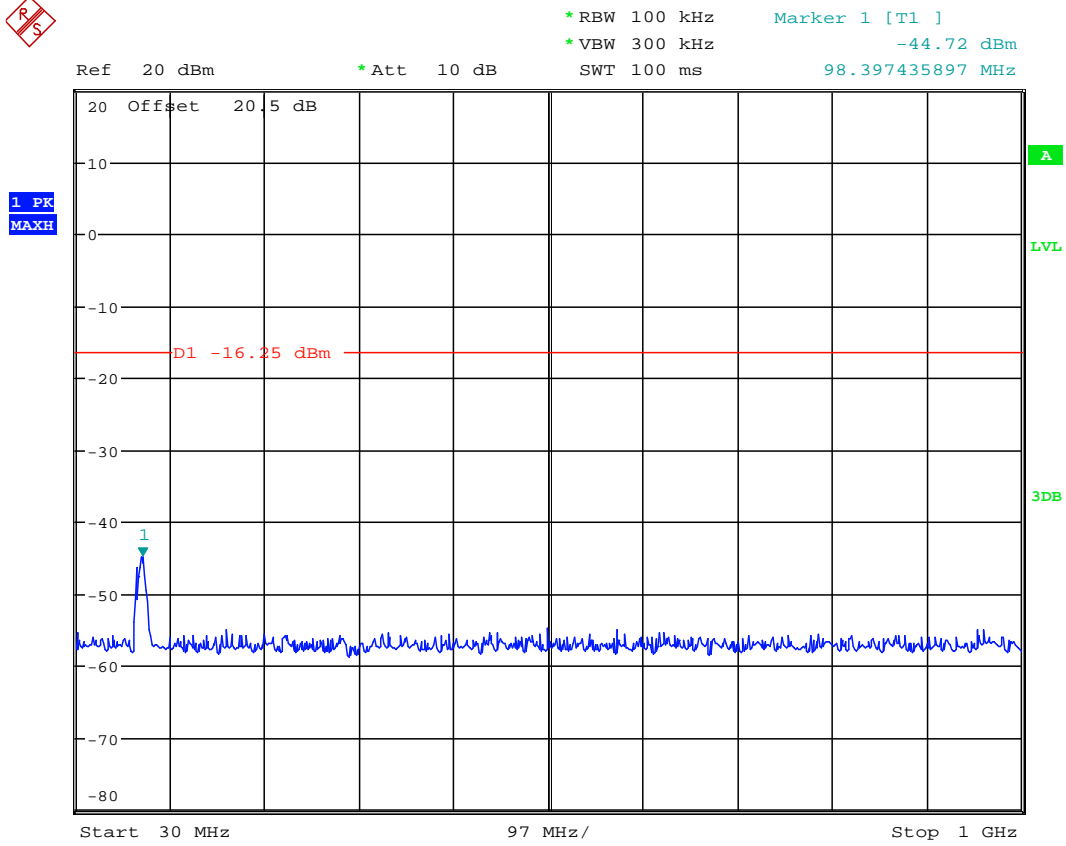
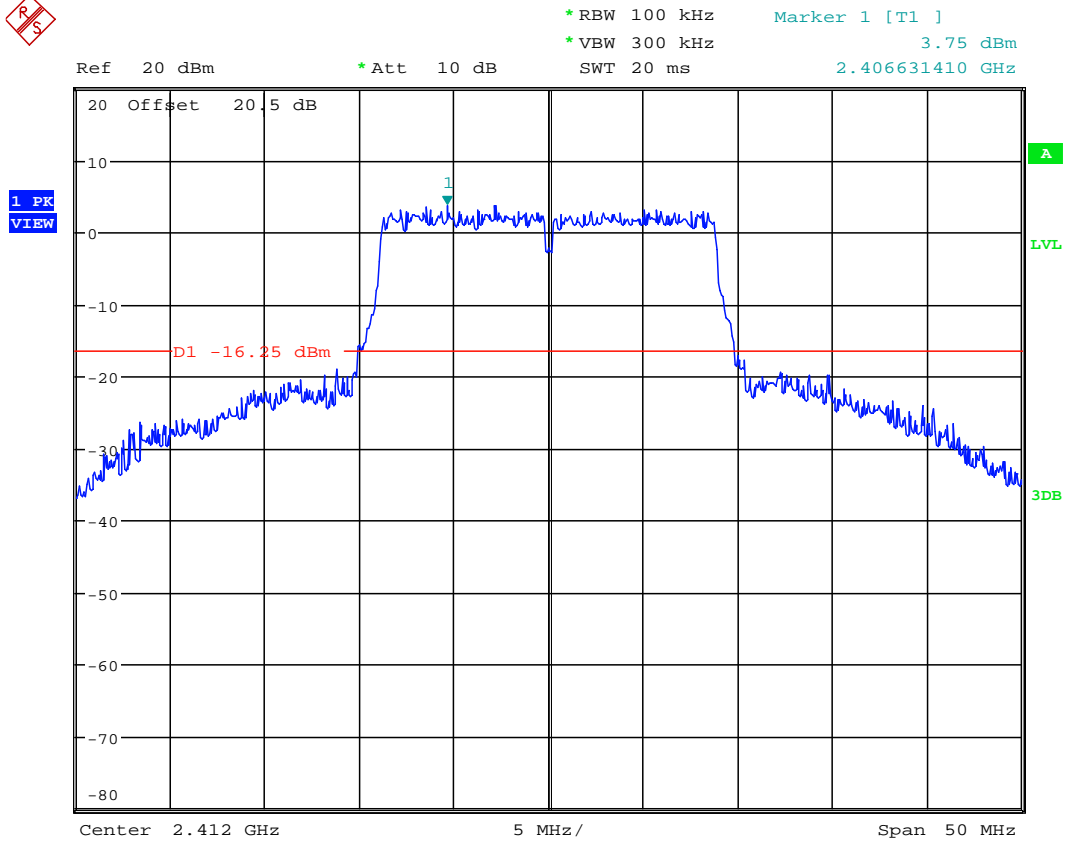

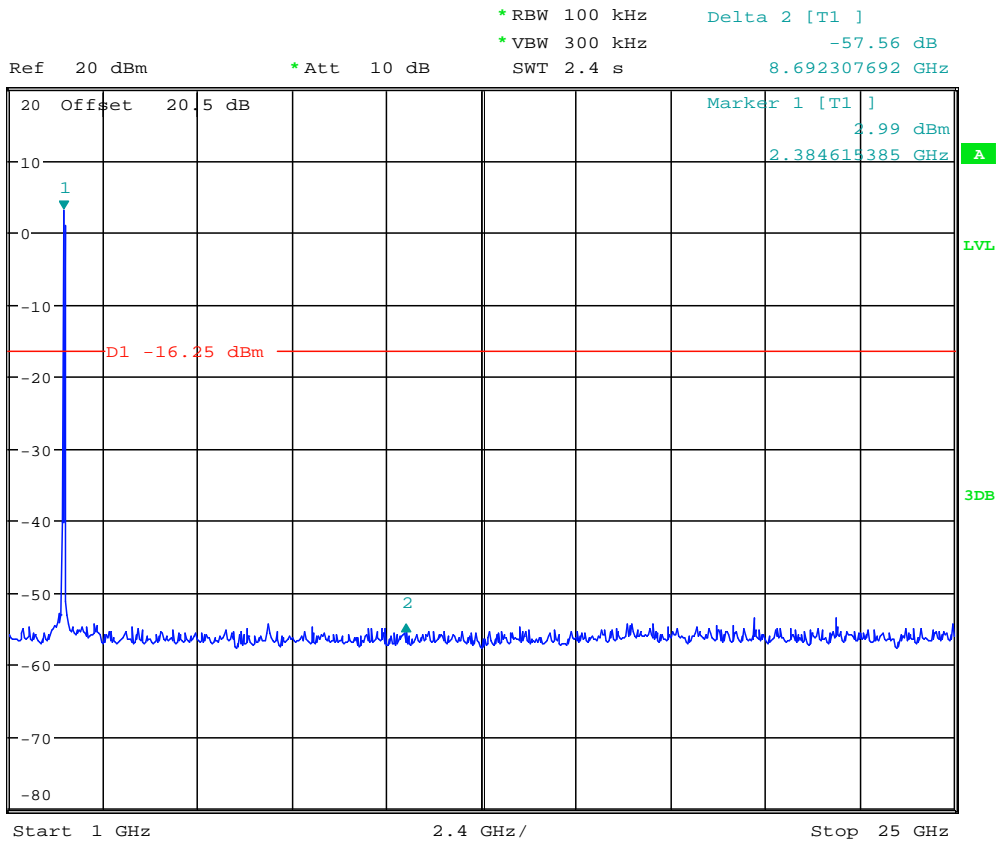

Chain 4 11n HT20 CH 6

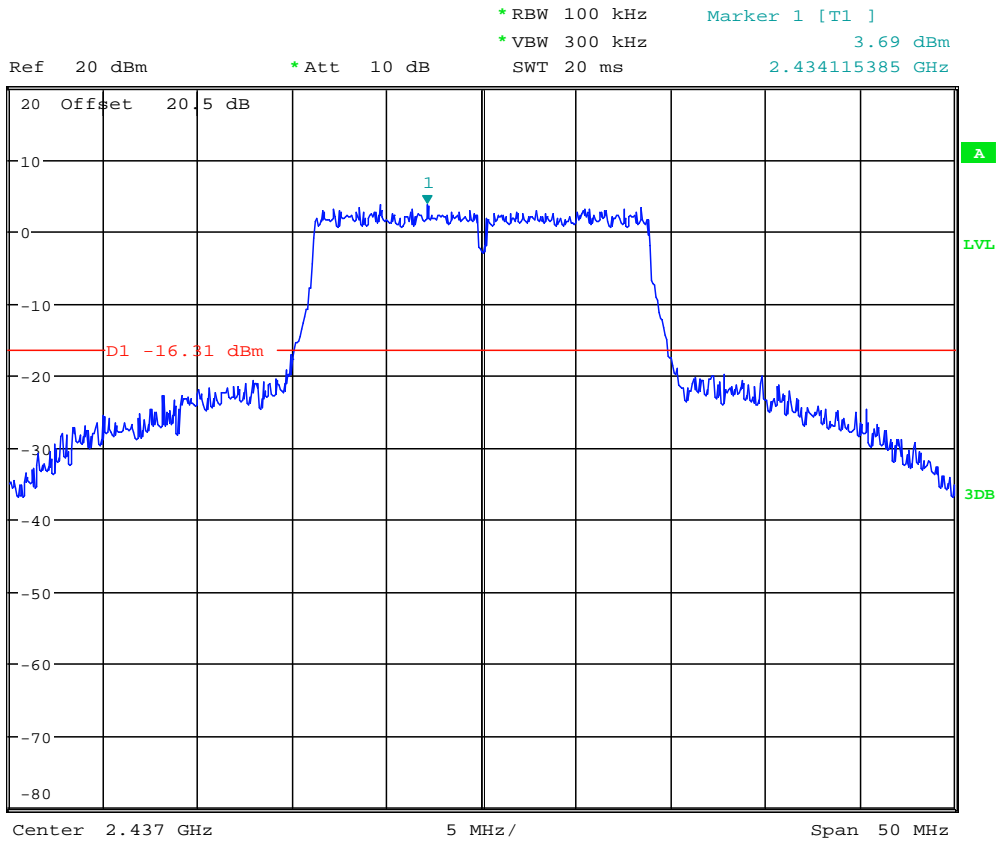

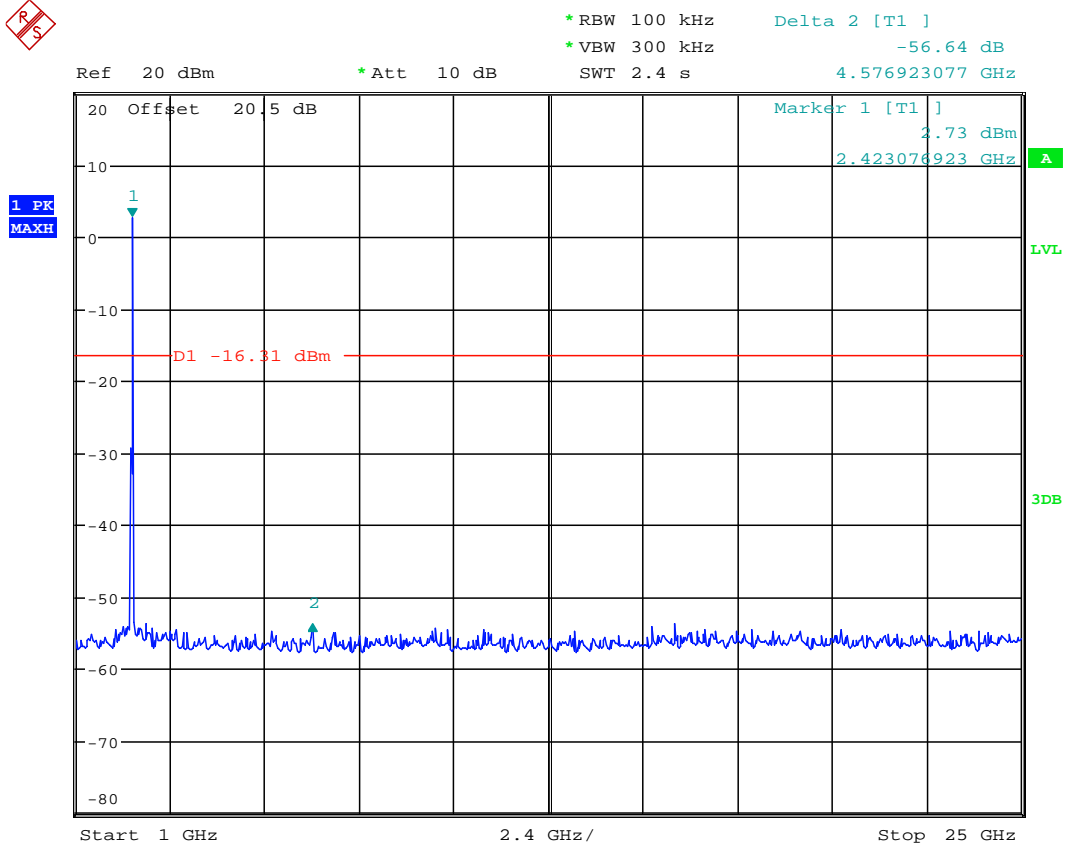
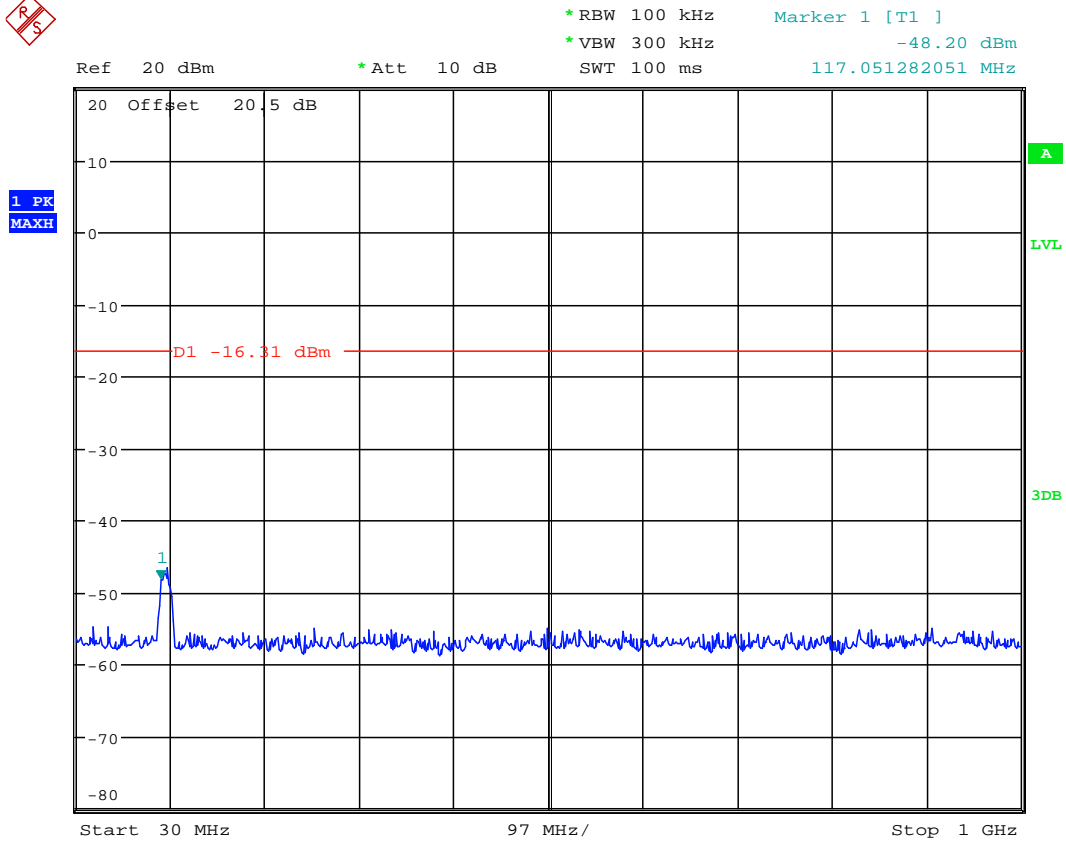

Chain 4 11n HT20 CH 11

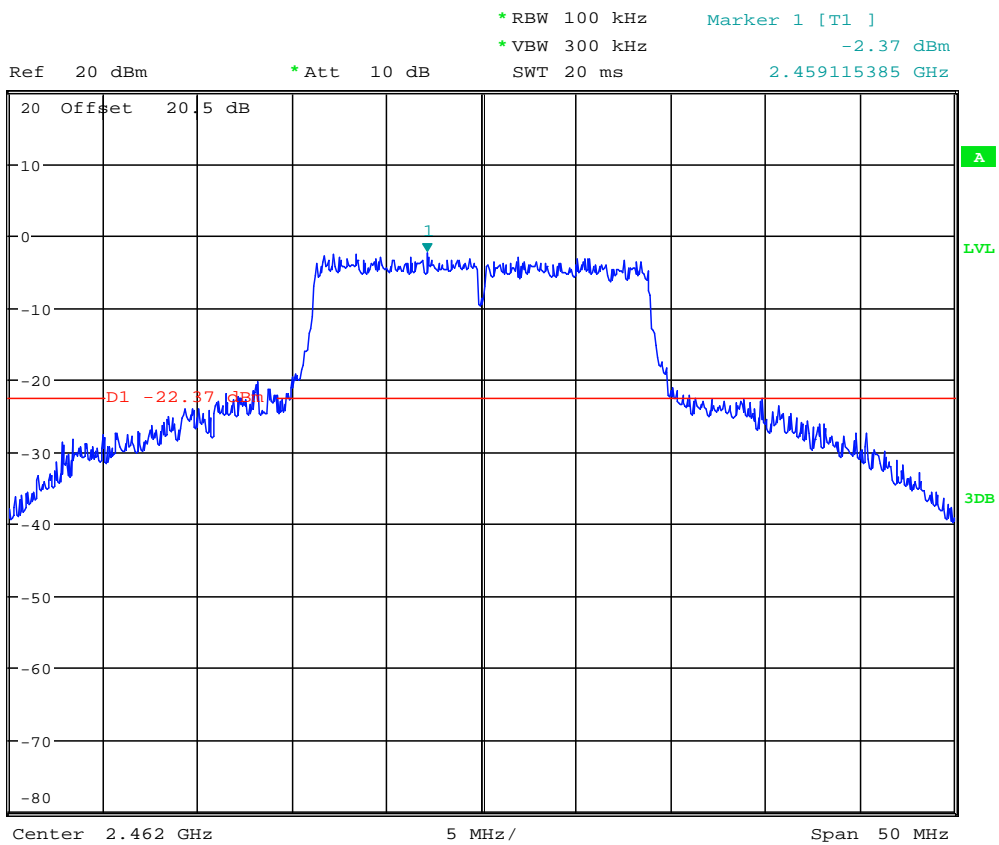
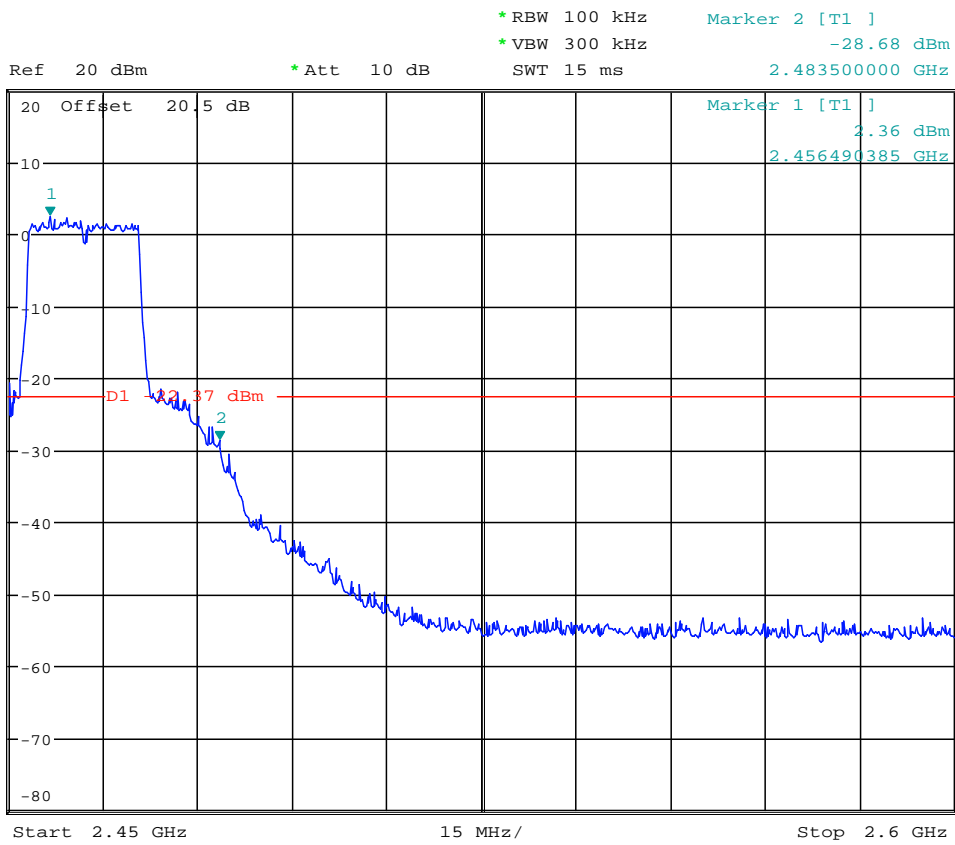

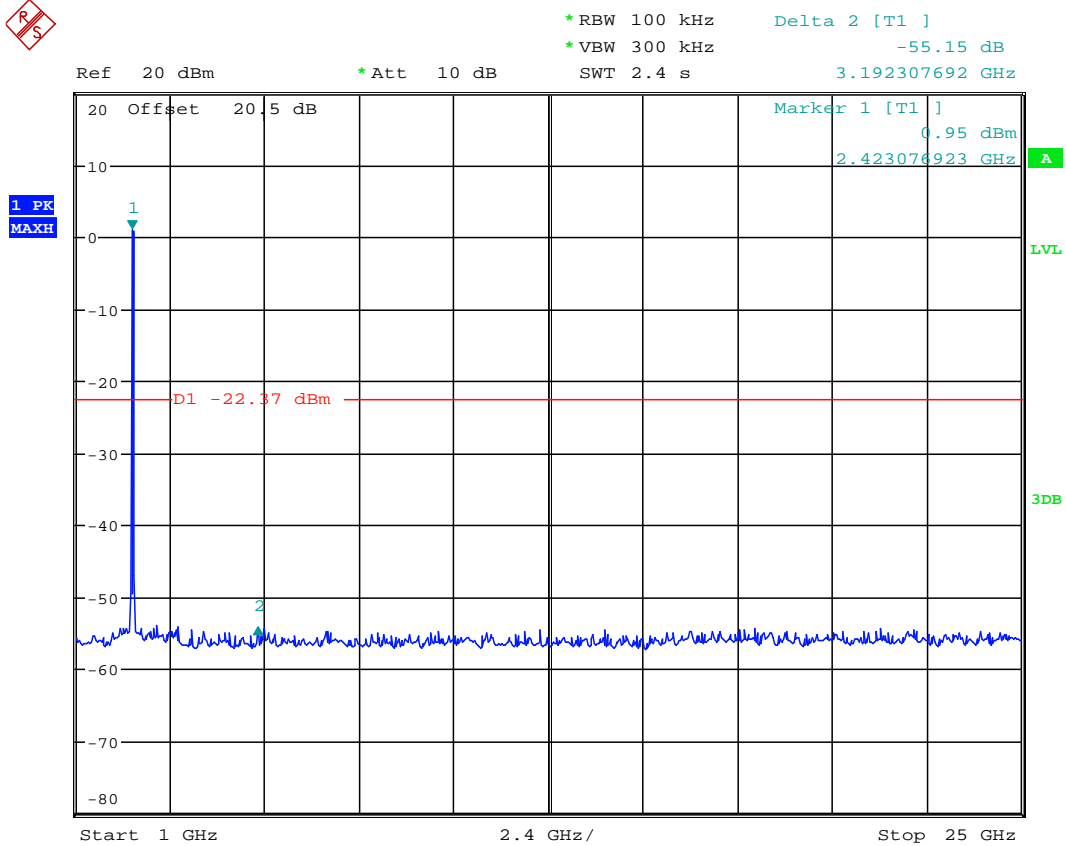
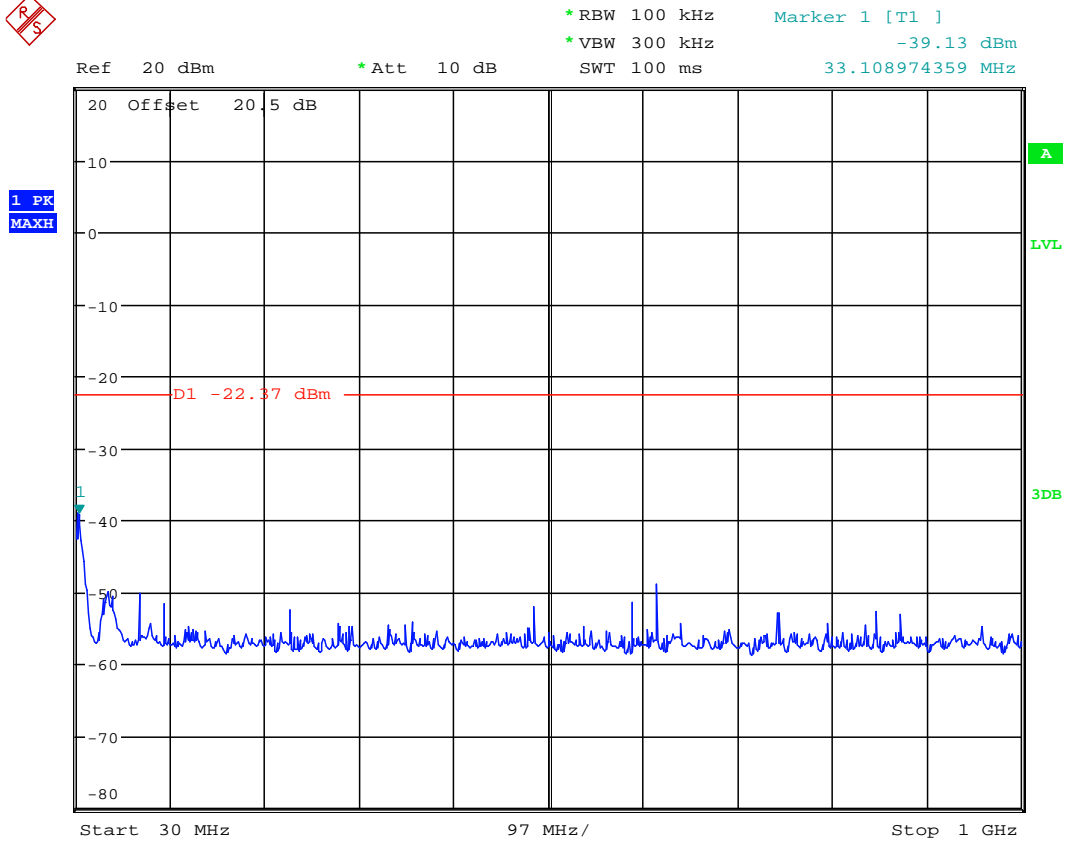



Ref 20 dBm *Att 10 dB *RBW 100 kHz Marker 1 [T1]
*VBW 300 kHz -45.88 dBm
SWT 100 ms 30.00000000 MHz

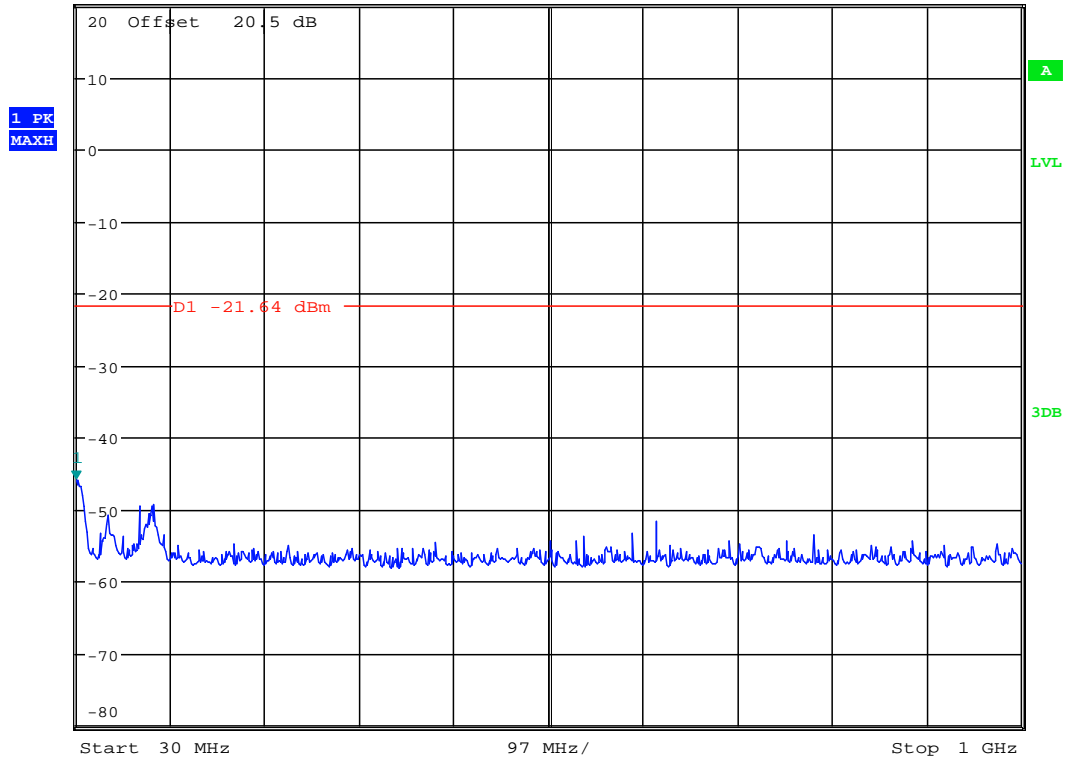

Ref 20 dBm *Att 10 dB *RBW 100 kHz Delta 2 [T1]
*VBW 300 kHz -49.78 dBm
SWT 2.4 s 4.807692308 GHz

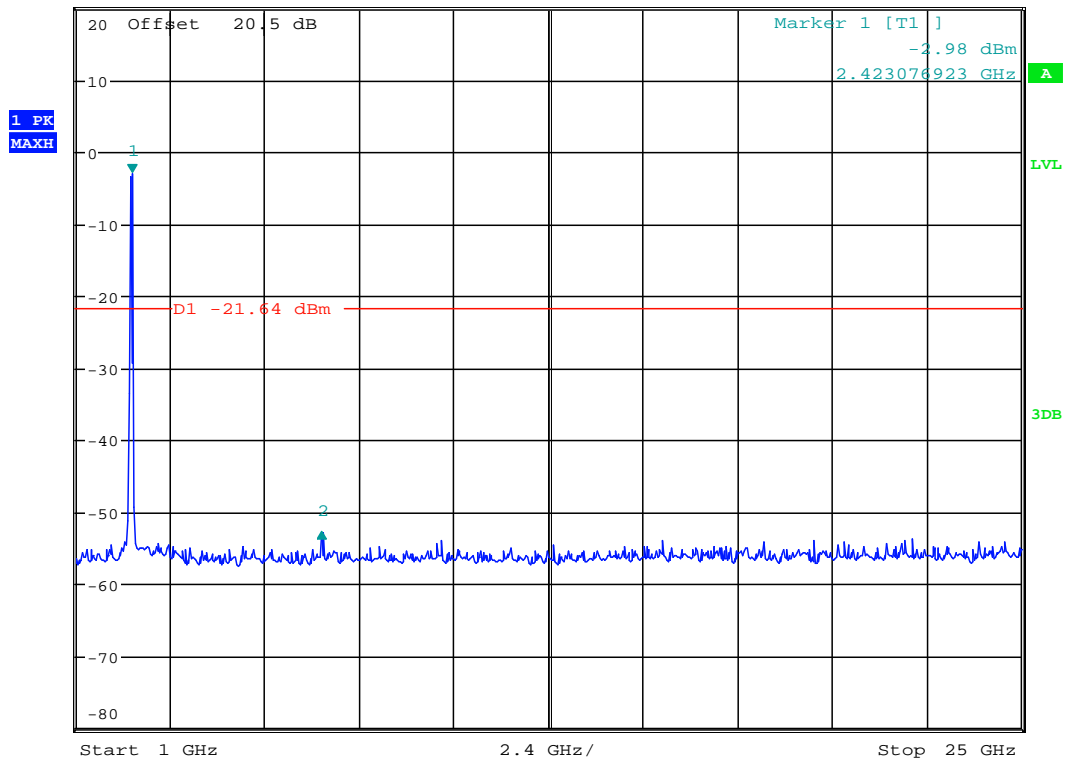

Chain 4 11n HT40 CH 6



Ref 20 dBm *Att 10 dB *RBW 100 kHz Marker 1 [T1]
*VBW 300 kHz -1.02 dBm
SWT 10 ms 2.421615385 GHz

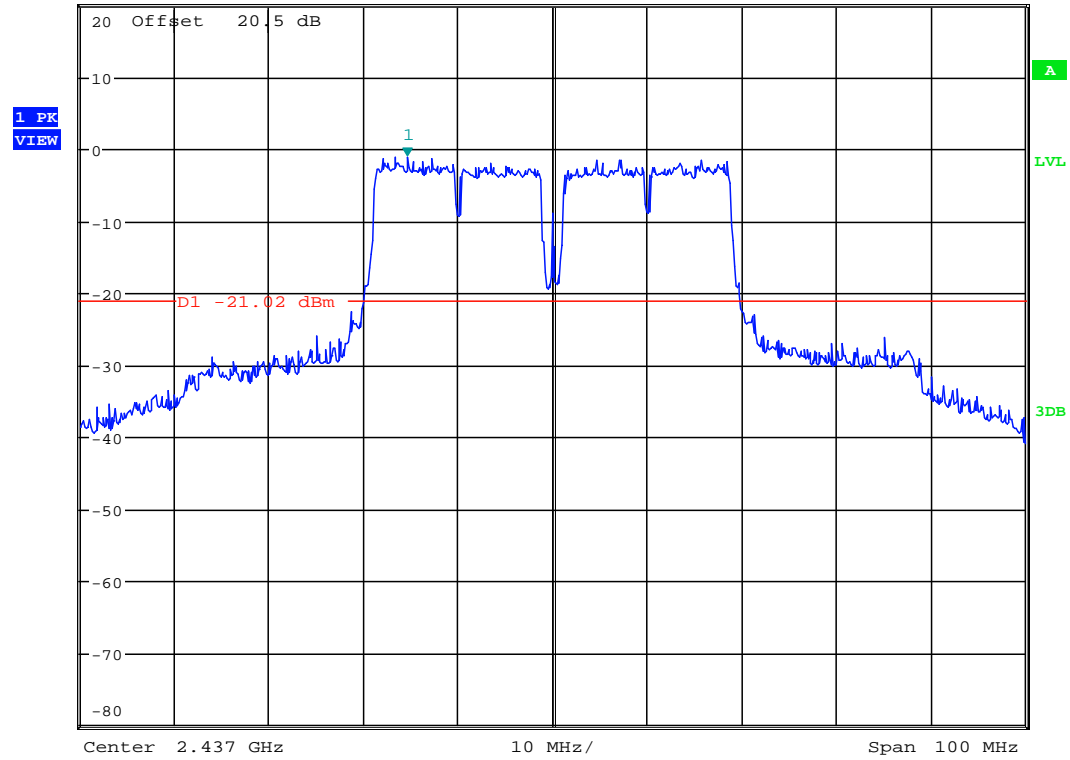

Ref 20 dBm *Att 10 dB *RBW 100 kHz Marker 1 [T1]
*VBW 300 kHz -50.02 dBm
SWT 100 ms 124.823717949 MHz

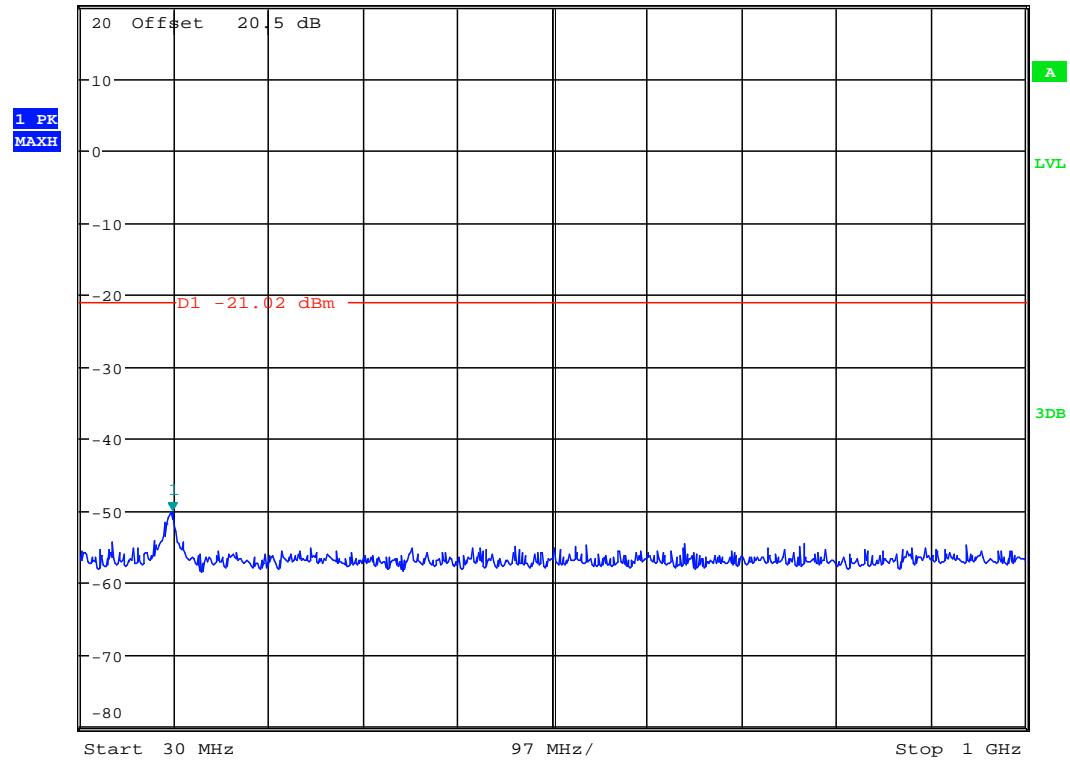

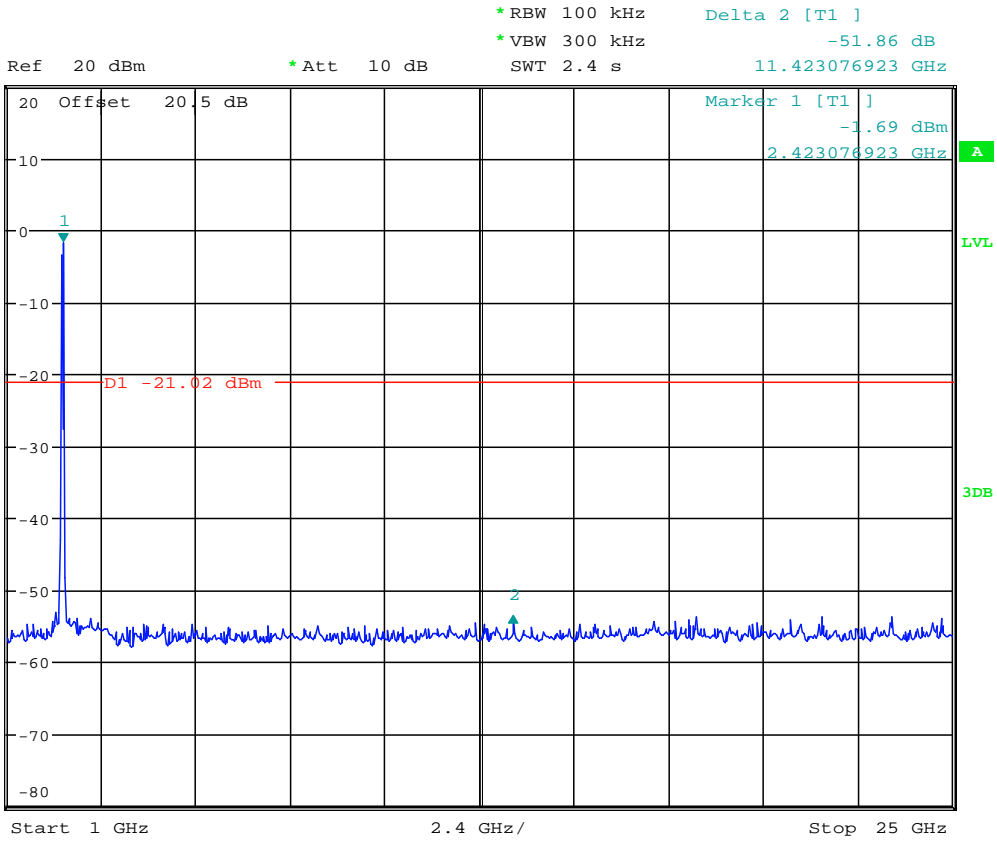

Chain 4 11n HT40 CH 9

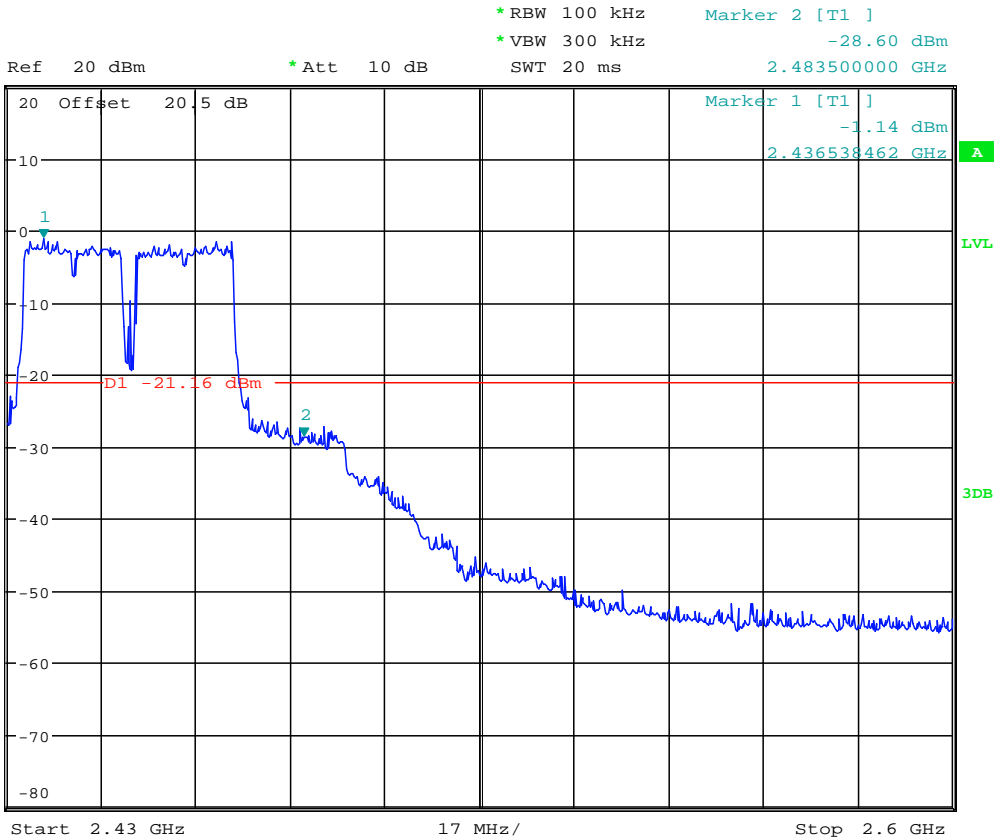

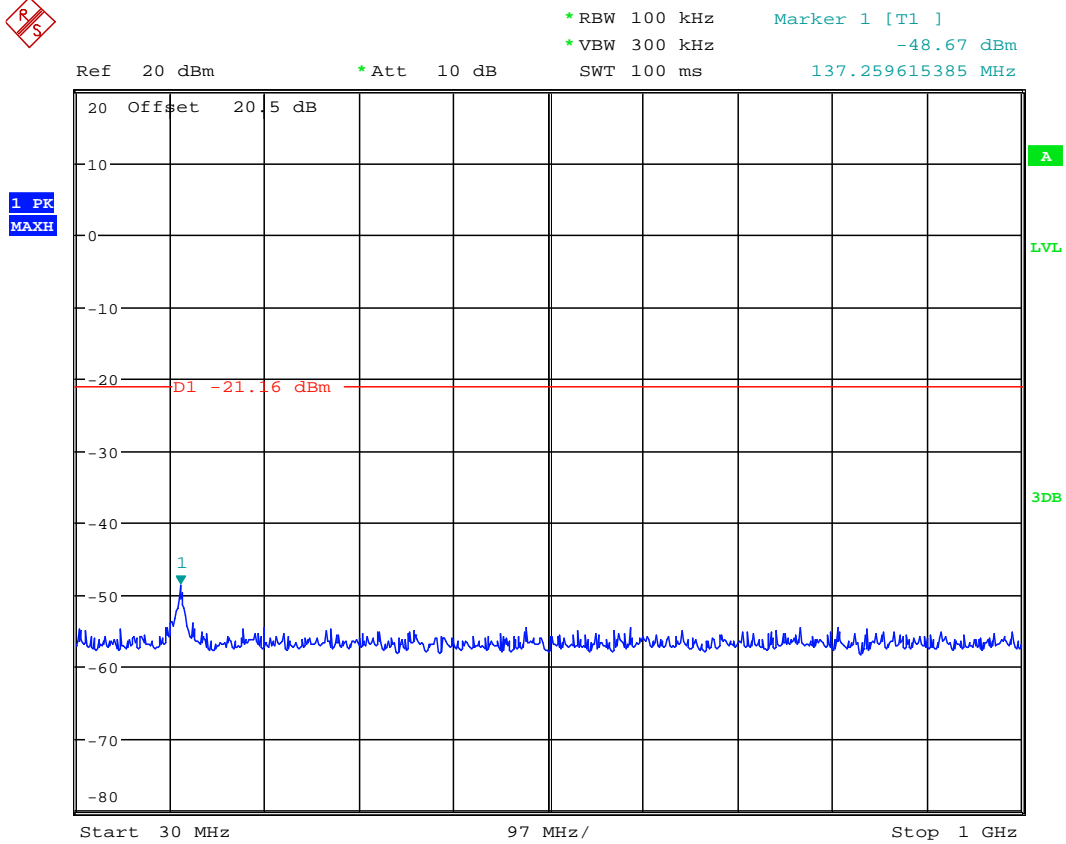
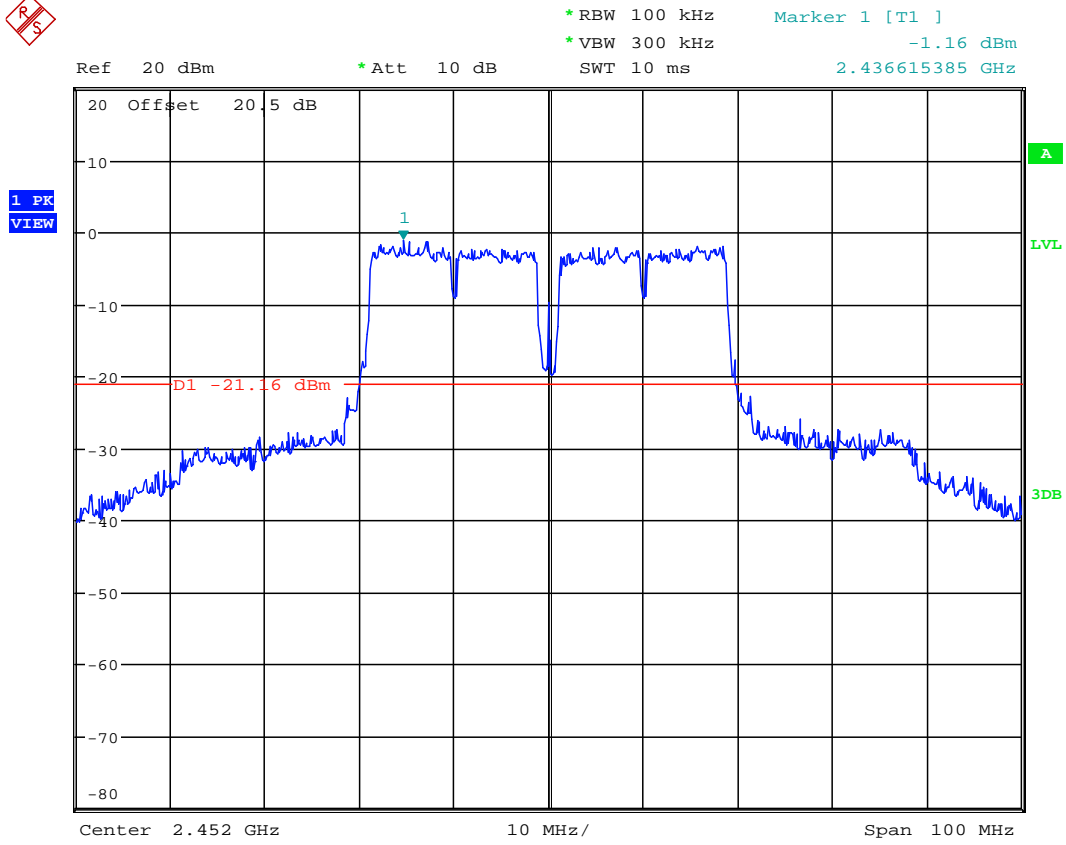

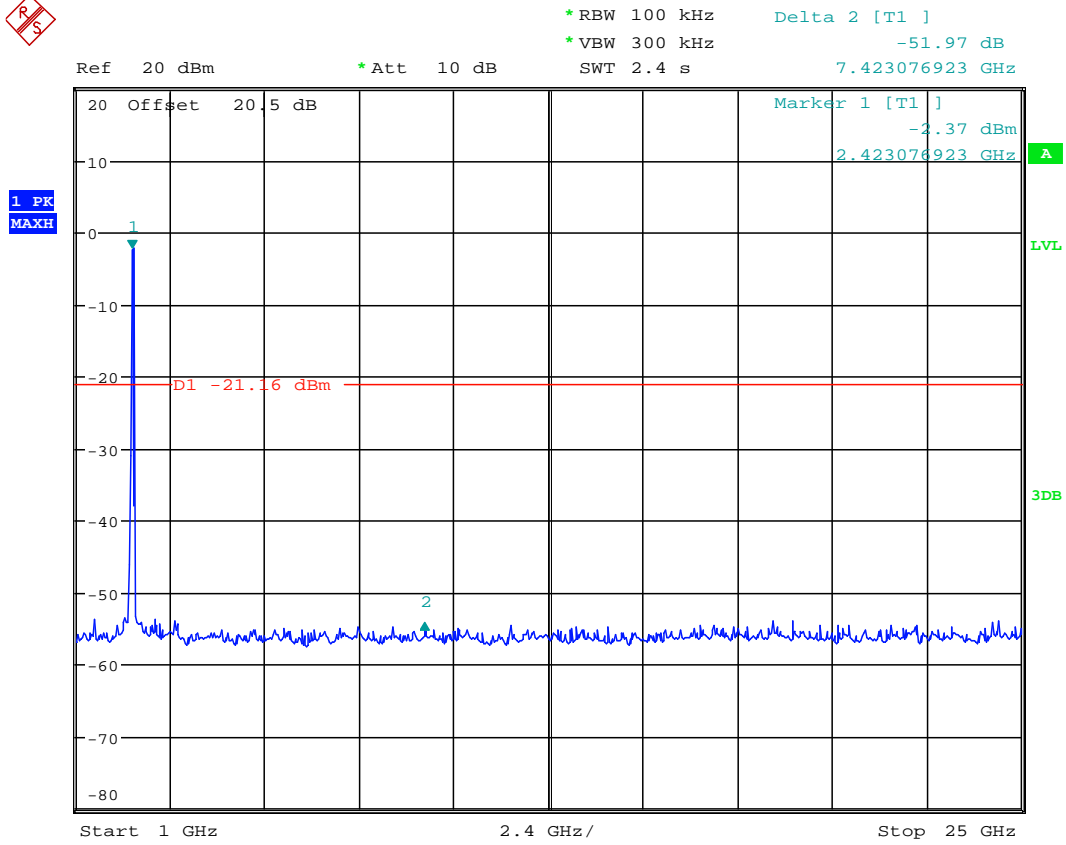

7. Emissions in restricted frequency bands

7.1. Test equipment

Item	Equipment	Manufacturer	Model No.	Serial No.	Last Cal.	Cal. Interval
1	EMI Test Receiver	R&S	ESU8	100316	2013/11/13	1 Year
2	Spectrum analyzer	R&S	FSU	1166.1660.26	2013/11/13	1 Year
3	Active Loop antenna	Schwarzbeck	FMZB1519	1519-038	2013/11/13	1 Year
4	Trilog Broadband Antenna	Schwarzbeck	VULB9163	9163-462	2013/11/13	1 Year
5	Double Ridged Horn Antenna	R&S	HF907	100276	2013/11/13	1 Year
6	Horn Antenna	EMCO	3116	00060095	2013/11/13	1 Year
7	Pre-Amplifier	R&S	SCU-01	10049	2013/11/13	1 Year
8	Pre-amplifier	A.H.	PAM0-0118	360	2013/11/13	1 Year
9	Pre-amplifier	A.H.	PAM-1840VH	562	2013/11/13	1 Year
10	RF Cable	R&S	R01	10403	2013/11/13	1 Year
11	RF Cable	R&S	R02	10512	2013/11/13	1 Year

7.2. Block diagram of test setup

In 3m Anechoic Chamber Test Setup Diagram for 9KHz-30MHz

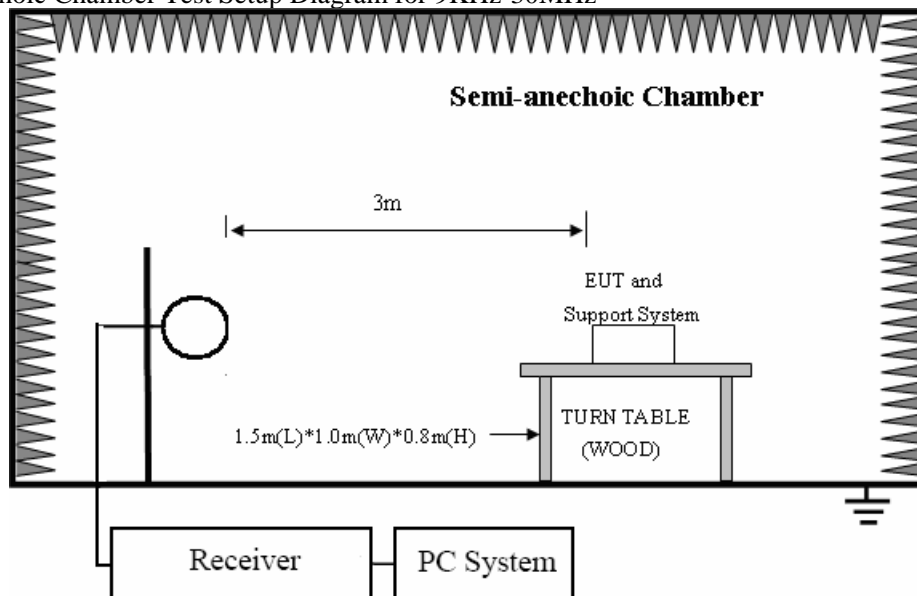

In 3m Anechoic Chamber Test Setup Diagram for 30MHz-1GHz

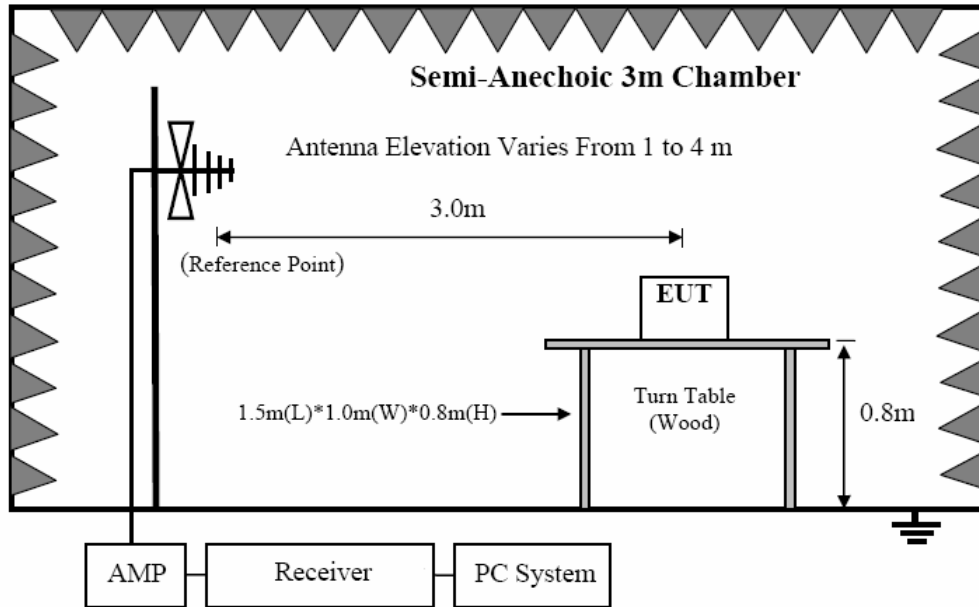

In 3m Anechoic Chamber Test Setup Diagram for frequency above 1GHz

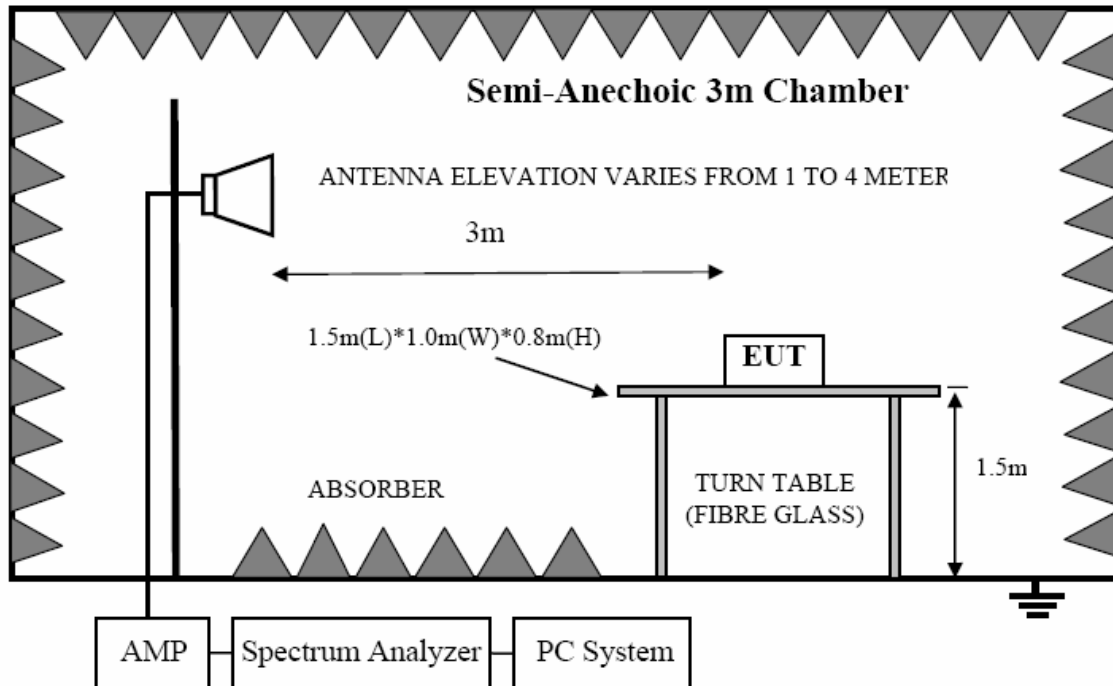

Note: For harmonic emissions test a appropriate high pass filter was inserted in the input port of AMP.

7.3. Limit

8.3.1 FCC 15.205 Restricted frequency band

MHz	MHz	MHz	GHz
0.090 - 0.110	16.42 - 16.423	399.9 - 410	4.5 - 5.15
¹ 0.495 - 0.505	16.69475 - 16.69525	608 - 614	5.35 - 5.46
2.1735 - 2.1905	16.80425 - 16.80475	960 - 1240	7.25 - 7.75
4.125 - 4.128	25.5 - 25.67	1300 - 1427	8.025 - 8.5
4.17725 - 4.17775	37.5 - 38.25	1435 - 1626.5	9.0 - 9.2
4.20725 - 4.20775	73 - 74.6	1645.5 - 1646.5	9.3 - 9.5
6.215 - 6.218	74.8 - 75.2	1660 - 1710	10.6 - 12.7
6.26775 - 6.26825	108 - 121.94	1718.8 - 1722.2	13.25 - 13.4
6.31175 - 6.31225	123 - 138	2200 - 2300	14.47 - 14.5
8.291 - 8.294	149.9 - 150.05	2310 - 2390	15.35 - 16.2
8.362 - 8.366	156.52475 - 156.52525	2483.5 - 2500	17.7 - 21.4
8.37625 - 8.38675	156.7 - 156.9	2690 - 2900	22.01 - 23.12
8.41425 - 8.41475	162.0125 - 167.17	3260 - 3267	23.6 - 24.0
12.29 - 12.293	167.72 - 173.2	3332 - 3339	31.2 - 31.8
12.51975 - 12.52025	240 - 285	3345.8 - 3358	36.43 - 36.5
12.57675 - 12.57725	322 - 335.4	3600 - 4400	(²)

8.3.2 FCC 15.209 Limit.

FREQUENCY MHz	DISTANCE Meters	FIELD STRENGTHS LIMIT	
		μV/m	dB(μV)/m
0.009 ~ 0.490	300	2400/F(KHz)	67.6-20log(F)
0.490 ~ 1.705	30	24000/F(KHz)	87.6-20log(F)
1.705 ~ 30.0	30	30	29.54
30 ~ 88	3	100	40.0
88 ~ 216	3	150	43.5
216 ~ 960	3	200	46.0
960 ~ 1000	3	500	54.0
Above 1000	3	74.0 dB(μV)/m (Peak) 54.0 dB(μV)/m (Average)	

Note: (1)The emission limits shown in the above table are based on measurements employing a CISPR QP detector except for the frequency bands 9-90KHz, 110-490KHz and above 1000MHz.Radiated emissions limits in these three bands are based on measurements employing an average detector.

(2) At frequencies below 30MHz, measurement may be performed at a distance closer then that specified, and the limit at closer measurement distance can be extrapolated by below formula:

$$\text{Limit}_{3m}(\text{dBuV/m}) = \text{Limit}_{30m}(\text{dBuV/m}) + 40\text{Log}(30m/3m)$$

8.3.3 Limit for this EUT

All the emissions appearing within 15.205 restricted frequency bands shall not exceed the limits shown in 15.209, all the other emissions shall be at least 20dB below the fundamental emissions, or comply with 15.209 limits.

7.4. Test Procedure

- (1) EUT was placed on a non-metallic table, 80 cm above the ground plane(for emissions below 1GHz) and 1.5m above the ground plane(for emissions above 1GHz) inside a semi-anechoic chamber.
- (2) Setup EUT and assistant system according clause 2.4 and 7.2
- (3) Test antenna was located 3m from the EUT on an adjustable mast, and the antenna used as below table.

Test frequency range	Test antenna used
9KHz-30MHz	Active Loop antenna
30MHz-1GHz	Trilog Broadband Antenna
1GHz-18GHz	Double Ridged Horn Antenna(1GHz-18GHz)
18GHz-40GHz	Horn Antenna(18GHz-40GHz)

According ANSI C63.10:2009 clause 6.4.4.2 and 6.5.3, for measurements below 30 MHz, the loop antenna was positioned with its plane vertical from the EUT and rotated about its vertical axis for maximum response at each azimuth position around the EUT. And the loop antenna also be positioned with its plane horizontal at the specified distance from the EUT. The center of the loop is 1 m above the ground. for measurement above 30MHz, the Trilog Broadband Antenna or Horn Antenna was located 3m from EUT, Measurements were made with the antenna positioned in both the horizontal and vertical planes of Polarization, and the measurement antenna was varied from 1 m to 4 m. in height above the reference ground plane to obtain the maximum signal strength.

- (4) Below pre-scan procedure was first performed in order to find prominent frequency spectrum radiated emissions from 9KHz to 25GHz:

- (a) Scanning the peak frequency spectrum with the antenna specified in step (3), and the EUT was rotated 360 degree, the antenna height was varied from 1m to 4m(Except loop antenna, it's fixed 1m above ground.)

- (b) Change work frequency or channel of device if practicable.

- (c) Change modulation type of device if practicable.

- (d) Change power supply range from 85% to 115% of the rated supply voltage

- (e) Rotated EUT though three orthogonal axes to determine the attitude of EUT arrangement produces highest emissions.

Spectrum frequency from 9KHz to 25GHz (tenth harmonic of fundamental frequency) was investigated, and no any obvious emission were detected from 18GHz to 25GHz, so below final test was performed with frequency range from 9KHz to 18GHz.

- (5) For final emissions measurements at each frequency of interest, the EUT was rotated and the antenna height was varied between 1m and 4m in order to maximize the emission. Measurements in both horizontal and vertical polarities were made and the data was recorded. In order to find the maximum emission, the relative positions of equipments and all of the interface cables were changed according to ANSI C63.10 2009 on Radiated Emission test.
- (6) The emissions from 9KHz to 1GHz were measured based on CISPR QP detector except for the

frequency bands 9-90KHz, 110-490KHz, for emissions from 9KHz-90KHz,110KHz-490KHz and above 1GHz were measured based on average detector, for emissions above 1GHz, peak emissions also be measured and need comply with Peak limit.

- (7) The emissions from 9KHz to 1GHz, QP or average values were measured with EMI receiver with below RBW

Frequency band	RBW
9KHz-150KHz	200Hz
150KHz-30MHz	9KHz
30MHz-1GHz	120KHz

- (8) For emissions above 1GHz, both Peak and Average level were measured with Spectrum Analyzer, and the RBW is set at 1MHz, VBW is set at 3MHz for Peak measure; RBW is set at 1MHz, VBW is set at 10Hz for Average measure(according ANSI C63.10:2009 clause 4.2.3.2.3 procedure for average measure).

7.5. Test result

PASS. (See below detailed test result)

All the emissions except fundamental emission from 9KHz to 25GHz were comply with 15.209 limit.

Note1: According exploratory test no any obvious emission were detected from 18GHz to 25GHz, so the final test was performed with frequency range from 9KHz to 18GHz and recorded in below.

Note2: For emissions below 1GHz, according exploratory explorer test, when change Tx mode and channel, have no distinct influence on emissions level, so for emissions below 1GHz, the final test was only performed with EUT working in 11b, Tx CH6 mode.

Note3: For emissions above 1GHz. If peak results comply with AV limit, AV Result is deemed to comply with AV limit.

Note4: For below test data, when the limit tabular marked “/” means this frequency point is the fundamental emission and no need comply with this limit.

TR-4-E-009 Radiated Emission Test Result

Test Site	: DDT 3m Chamber	E:\2014 Report Data\hongjirui\RE.EM6
Test Date	: 2014-08-31	Tested By : Leo
EUT	: Turning	Model Number : RRAP-01
Power Supply	: AC 120V/60Hz	Test Mode : Tx mode
Condition	: Temp:24.5'C,Humi:55%, Press:100.1kPa	Antenna/Distance : VULB 9163 2014-05/3m/HORIZONTAL
Memo	:	

Data: 1

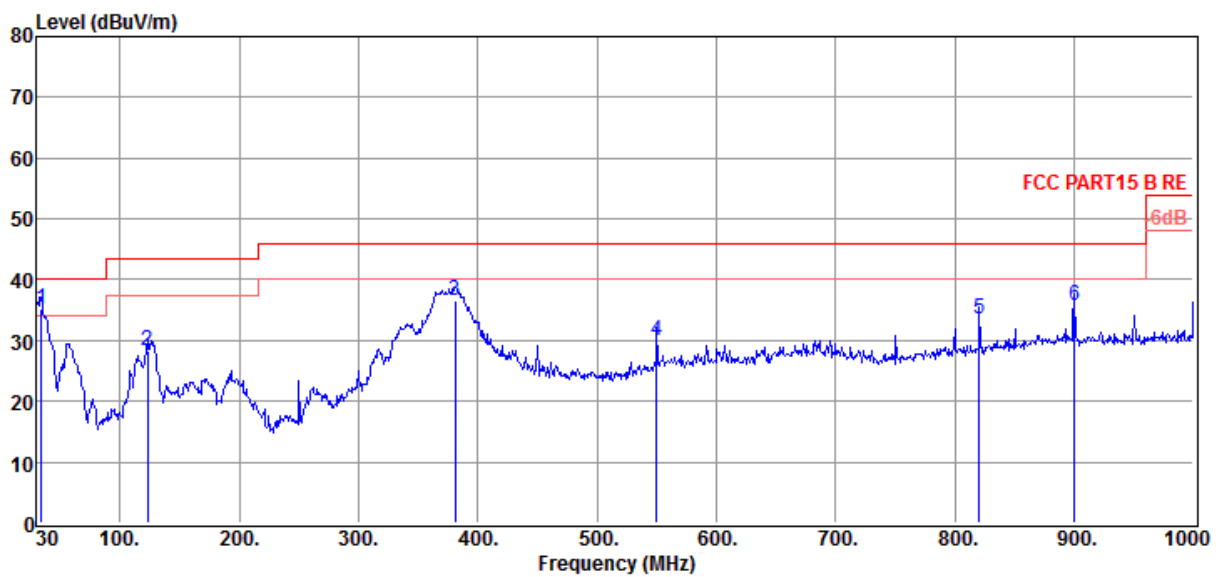

Item (Mark)	Freq (MHz)	Read Level (dBμV)	Antenna Factor (dB/m)	Cable Loss dB	Result Level (dBμV/m)	Limit Line (dBμV/m)	Over Limit (dB)	Detector	Polarization
1	33.88	21.83	12.30	0.94	35.07	40.00	-4.93	QP	HORIZONTAL
2	123.12	17.23	9.37	1.58	28.18	43.50	-15.32	QP	HORIZONTAL
3	381.14	17.98	15.52	3.17	36.67	46.00	-9.33	QP	HORIZONTAL
4	549.92	9.15	17.10	3.82	30.07	46.00	-15.93	QP	HORIZONTAL
5	820.55	8.16	20.68	4.72	33.56	46.00	-12.44	QP	HORIZONTAL
6	900.09	8.59	22.10	4.96	35.65	46.00	-10.35	QP	HORIZONTAL

- Note: 1. Result Level = Read Level + Antenna Factor + Cable loss.
 2. If Peak Result complies with QP limit, QP Result is deemed to comply with QP limit.
 3. Test setup: RBW: 120 kHz, VBW: 300 kHz, Sweep time: auto.

TR-4-E-009 Radiated Emission Test Result

Test Site	: DDT 3m Chamber	E:\2014 Report Data\hongjirui\RE.EM6
Test Date	: 2014-08-31	Tested By : Leo
EUT	: Turning	Model Number : RRAP-01
Power Supply	: AC 120V/60Hz	Test Mode : Tx mode
Condition	: Temp:24.5'C,Humi:55%, Press:100.1kPa	Antenna/Distance : VULB 9163 2014-05/3m/VERTICAL
Memo	:	

Data: 2

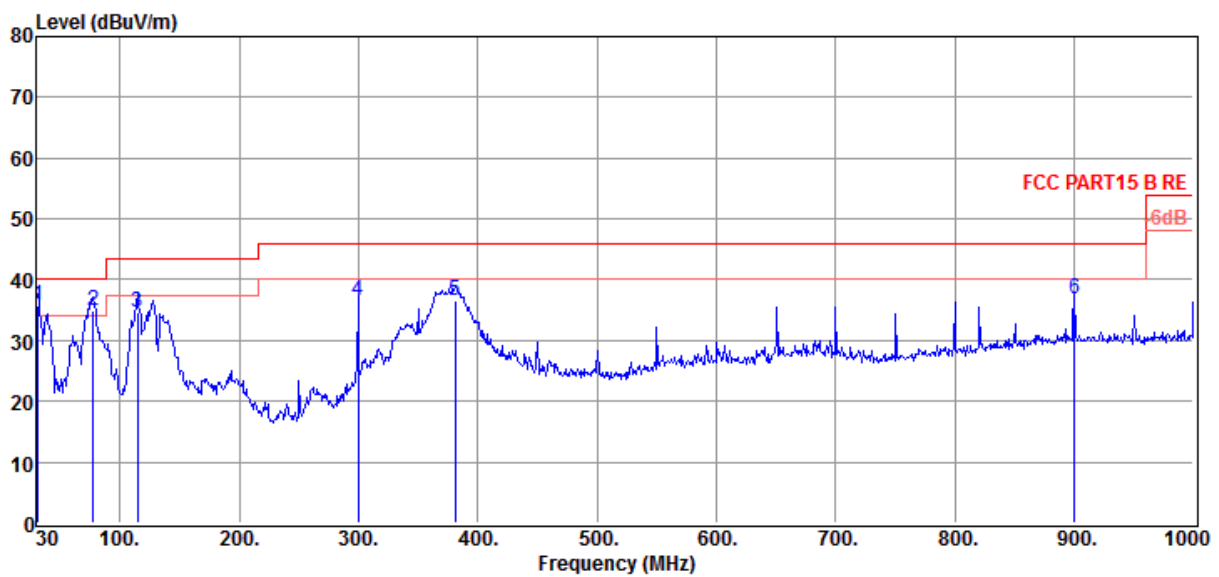

Item (Mark)	Freq (MHz)	Read Level (dBμV)	Antenna Factor (dB/m)	Cable Loss dB	Result Level (dBμV/m)	Limit Line (dBμV/m)	Over Limit (dB)	Detector	Polarization
1	30.97	22.92	11.95	0.92	35.79	40.00	-4.21	QP	VERTICAL
2	77.53	26.08	7.65	1.32	35.05	40.00	-4.95	QP	VERTICAL
3	114.39	21.98	11.10	1.54	34.62	43.50	-8.88	QP	VERTICAL
4	299.66	20.38	13.40	2.70	36.48	46.00	-9.52	QP	VERTICAL
5	381.14	17.98	15.52	3.17	36.67	46.00	-9.33	QP	VERTICAL
6	900.09	9.77	22.10	4.96	36.83	46.00	-9.17	QP	VERTICAL

- Note: 1. Result Level = Read Level + Antenna Factor + Cable loss.
 2. If Peak Result complies with QP limit, QP Result is deemed to comply with QP limit.
 3. Test setup: RBW: 120 kHz, VBW: 300 kHz, Sweep time: auto.

TR-4-E-009 Radiated Emission Test Result

Test Site : DDT 3m Chamber	E:\2014 Report Data\hongjirui\RF.EM6
Test Date : 2014-08-31	Tested By : Leo
EUT : Turning	Model Number : RRAP-01
Power Supply : AC 120V/60Hz	Test Mode : Tx mode 11b CH1
Condition : Temp:24.5'C,Humi:55%, Press:100.1kPa	Antenna/Distance : 2013 HF907/3m/VERTICAL
Memo :	

Data: 1

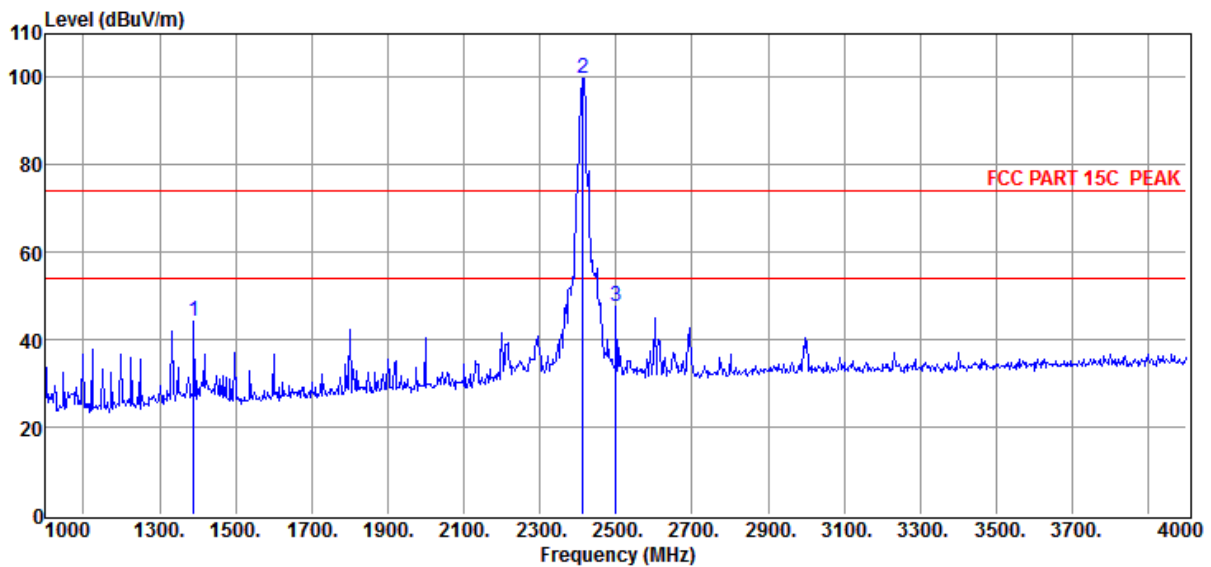

Item (Mark)	Freq (MHz)	Read Level (dBμV)	Antenna Factor (dB/m)	PRM Factor dB	Cable Loss dB	Result Level (dBμV/m)	Limit Line (dBμV/m)	Over Limit (dB)	Detector	Polarization
1	1390.00	55.35	25.95	43.29	6.38	44.39	74.00	-29.61	Peak	VERTICAL
2	2413.00	105.08	30.04	43.49	8.35	99.98	74.00	25.98	Peak	VERTICAL
3	2500.00	52.42	30.30	43.50	8.50	47.72	74.00	-26.28	Peak	VERTICAL

Note: 1. Result Level = Read Level + Antenna Factor + Cable loss - PRM Factor.
 2. If Peak Result complies with AV limit, AV Result is deemed to comply with AV limit.
 3. Test setup: RBW: 1 MHz, VBW: 3 MHz, Sweep time: auto.

TR-4-E-009 Radiated Emission Test Result

Test Site	: DDT 3m Chamber	E:\2014 Report Data\hongjirui\RF.EM6
Test Date	: 2014-08-31	Tested By : Leo
EUT	: Turning	Model Number : RRAP-01
Power Supply	: AC 120V/60Hz	Test Mode : Tx mode 11b CH1
Condition	: Temp:24.5'C,Humi:55%, Press:100.1kPa	Antenna/Distance : 2013 HF907/3m/HORIZONTAL
Memo	:	

Data: 2

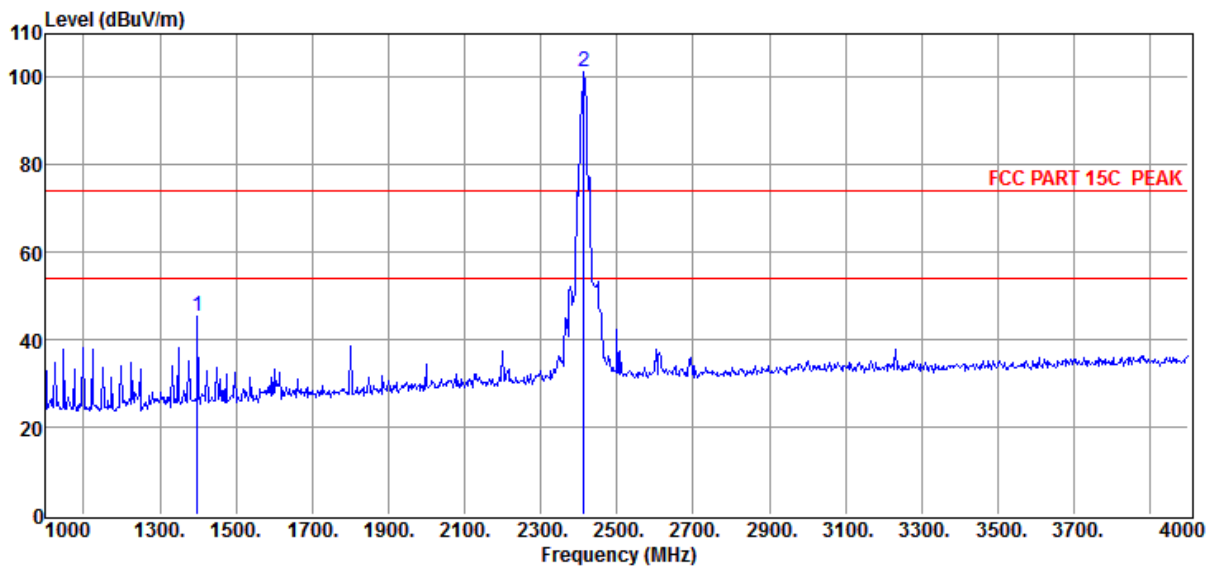

Item (Mark)	Freq (MHz)	Read Level (dBμV)	Antenna Factor (dB/m)	PRM Factor dB	Cable Loss dB	Result Level (dBμV/m)	Limit Line (dBμV/m)	Over Limit (dB)	Detector	Polarization
1	1399.00	56.11	25.95	43.29	6.42	45.19	74.00	-28.81	Peak	HORIZONTAL
2	2413.00	106.47	30.04	43.49	8.35	101.37	74.00	27.37	Peak	HORIZONTAL

- Note: 1. Result Level = Read Level + Antenna Factor + Cable loss - PRM Factor.
 2. If Peak Result complies with AV limit, AV Result is deemed to comply with AV limit.
 3. Test setup: RBW: 1 MHz, VBW: 3 MHz, Sweep time: auto.

TR-4-E-009 Radiated Emission Test Result

Test Site : DDT 3m Chamber	E:\2014 Report Data\hongjirui\RF.EM6
Test Date : 2014-08-31	Tested By : Leo
EUT : Turning	Model Number : RRAP-01
Power Supply : AC 120V/60Hz	Test Mode : Tx mode 11b CH6
Condition : Temp:24.5'C,Humi:55%, Press:100.1kPa	Antenna/Distance : 2013 HF907/3m/VERTICAL
Memo :	

Data: 5

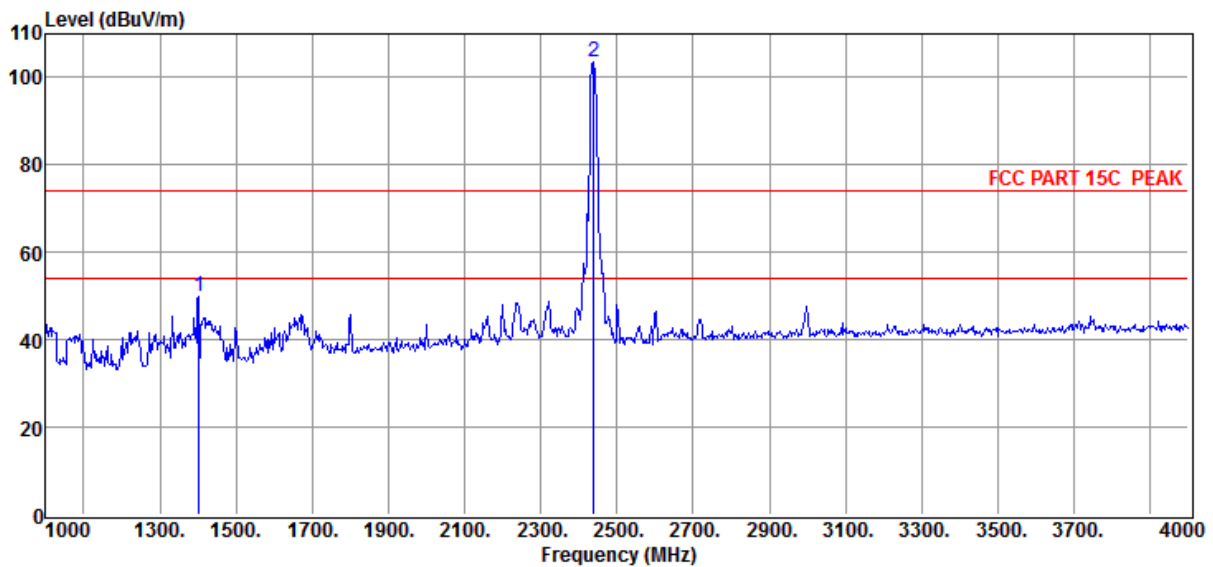

Item (Mark)	Freq (MHz)	Read Level (dBμV)	Antenna Factor (dB/m)	PRM Factor dB	Cable Loss dB	Result Level (dBμV/m)	Limit Line (dBμV/m)	Over Limit (dB)	Detector	Polarization
1	1402.00	60.66	26.01	43.31	6.42	49.78	74.00	-24.22	Peak	VERTICAL
2	2440.00	108.62	30.14	43.49	8.40	103.67	74.00	29.67	Peak	VERTICAL

- Note: 1. Result Level = Read Level + Antenna Factor + Cable loss - PRM Factor.
 2. If Peak Result complies with AV limit, AV Result is deemed to comply with AV limit.
 3. Test setup: RBW: 1 MHz, VBW: 3 MHz, Sweep time: auto.

TR-4-E-009 Radiated Emission Test Result

Test Site	: DDT 3m Chamber	E:\2014 Report Data\hongjirui\RF.EM6
Test Date	: 2014-08-31	Tested By : Leo
EUT	: Turning	Model Number : RRAP-01
Power Supply	: AC 120V/60Hz	Test Mode : Tx mode 11b CH6
Condition	: Temp:24.5'C,Humi:55%, Press:100.1kPa	Antenna/Distance : 2013 HF907/3m/HORIZONTAL
Memo	:	

Data: 6

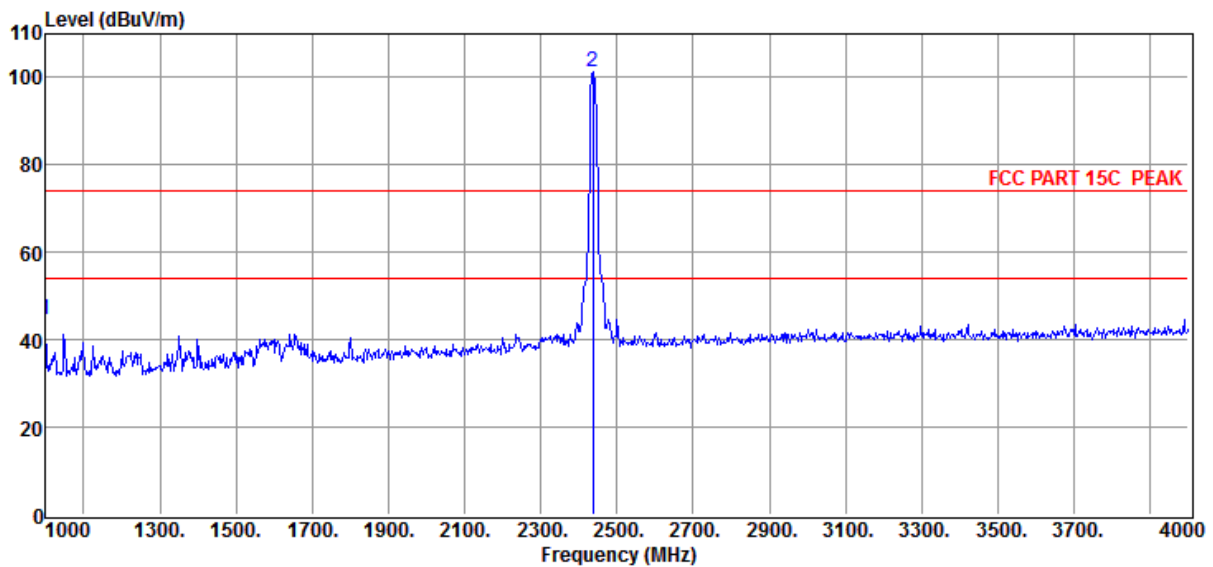

Item (Mark)	Freq (MHz)	Read Level (dBμV)	Antenna Factor (dB/m)	PRM Factor dB	Cable Loss dB	Result Level (dBμV/m)	Limit Line (dBμV/m)	Over Limit (dB)	Detector	Polarization
1	1000.00	57.83	24.60	43.16	5.40	44.67	74.00	-29.33	Peak	HORIZONTAL
2	2437.00	106.41	30.14	43.49	8.40	101.46	74.00	27.46	Peak	HORIZONTAL

- Note: 1. Result Level = Read Level + Antenna Factor + Cable loss - PRM Factor.
 2. If Peak Result complies with AV limit, AV Result is deemed to comply with AV limit.
 3. Test setup: RBW: 1 MHz, VBW: 3 MHz, Sweep time: auto.

TR-4-E-009 Radiated Emission Test Result

Test Site	: DDT 3m Chamber	E:\2014 Report Data\hongjirui\RF.EM6
Test Date	: 2014-08-31	Tested By : Leo
EUT	: Turning	Model Number : RRAP-01
Power Supply	: AC 120V/60Hz	Test Mode : Tx mode 11b CH11
Condition	: Temp:24.5'C,Humi:55%, Press:100.1kPa	Antenna/Distance : 2013 HF907/3m/HORIZONTAL
Memo	:	

Data: 7

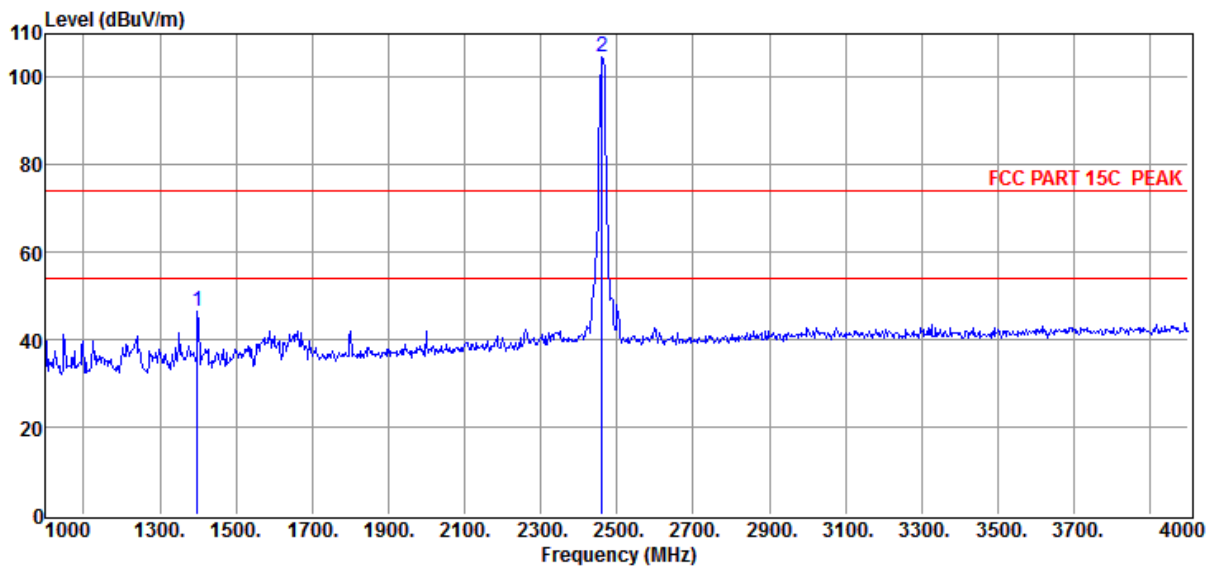

Item (Mark)	Freq (MHz)	Read Level (dBμV)	Antenna Factor (dB/m)	PRM Factor dB	Cable Loss dB	Result Level (dBμV/m)	Limit Line (dBμV/m)	Over Limit (dB)	Detector	Polarization
1	1399.00	57.48	25.95	43.29	6.42	46.56	74.00	-27.44	Peak	HORIZONTAL
2	2461.00	109.58	30.20	43.49	8.45	104.74	74.00	30.74	Peak	HORIZONTAL

- Note: 1. Result Level = Read Level + Antenna Factor + Cable loss - PRM Factor.
 2. If Peak Result complies with AV limit, AV Result is deemed to comply with AV limit.
 3. Test setup: RBW: 1 MHz, VBW: 3 MHz, Sweep time: auto.

TR-4-E-009 Radiated Emission Test Result

Test Site : DDT 3m Chamber	E:\2014 Report Data\hongjirui\RF.EM6
Test Date : 2014-08-31	Tested By : Leo
EUT : Turning	Model Number : RRAP-01
Power Supply : AC 120V/60Hz	Test Mode : Tx mode 11b CH11
Condition : Temp:24.5'C,Humi:55%, Press:100.1kPa	Antenna/Distance : 2013 HF907/3m/VERTICAL
Memo :	

Data: 8

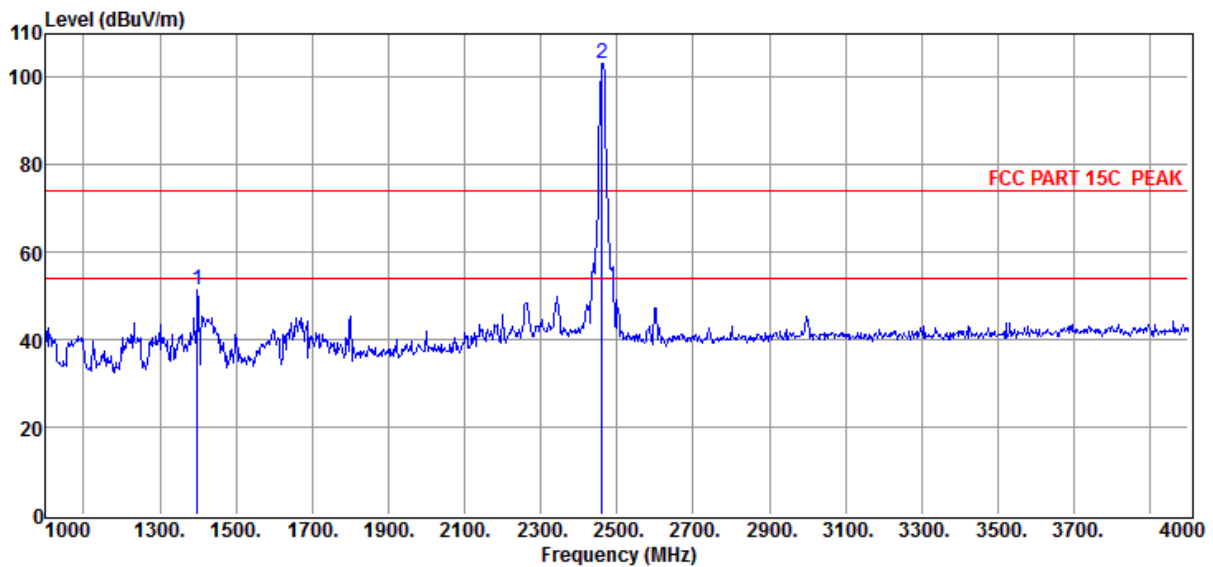

Item (Mark)	Freq (MHz)	Read Level (dBμV)	Antenna Factor (dB/m)	PRM Factor dB	Cable Loss dB	Result Level (dBμV/m)	Limit Line (dBμV/m)	Over Limit (dB)	Detector	Polarization
1	1399.00	62.35	25.95	43.29	6.42	51.43	74.00	-22.57	Peak	VERTICAL
2	2461.00	108.12	30.20	43.49	8.45	103.28	74.00	29.28	Peak	VERTICAL

- Note: 1. Result Level = Read Level + Antenna Factor + Cable loss - PRM Factor.
 2. If Peak Result complies with AV limit, AV Result is deemed to comply with AV limit.
 3. Test setup: RBW: 1 MHz, VBW: 3 MHz, Sweep time: auto.

TR-4-E-009 Radiated Emission Test Result

Test Site	: DDT 3m Chamber	E:\2014 Report Data\hongjirui\RF.EM6
Test Date	: 2014-08-31	Tested By : Leo
EUT	: Turning	Model Number : RRAP-01
Power Supply	: AC 120V/60Hz	Test Mode : Tx mode 11g CH1
Condition	: Temp:24.5'C,Humi:55%, Press:100.1kPa	Antenna/Distance : 2013 HF907/3m/HORIZONTAL
Memo	:	

Data: 13

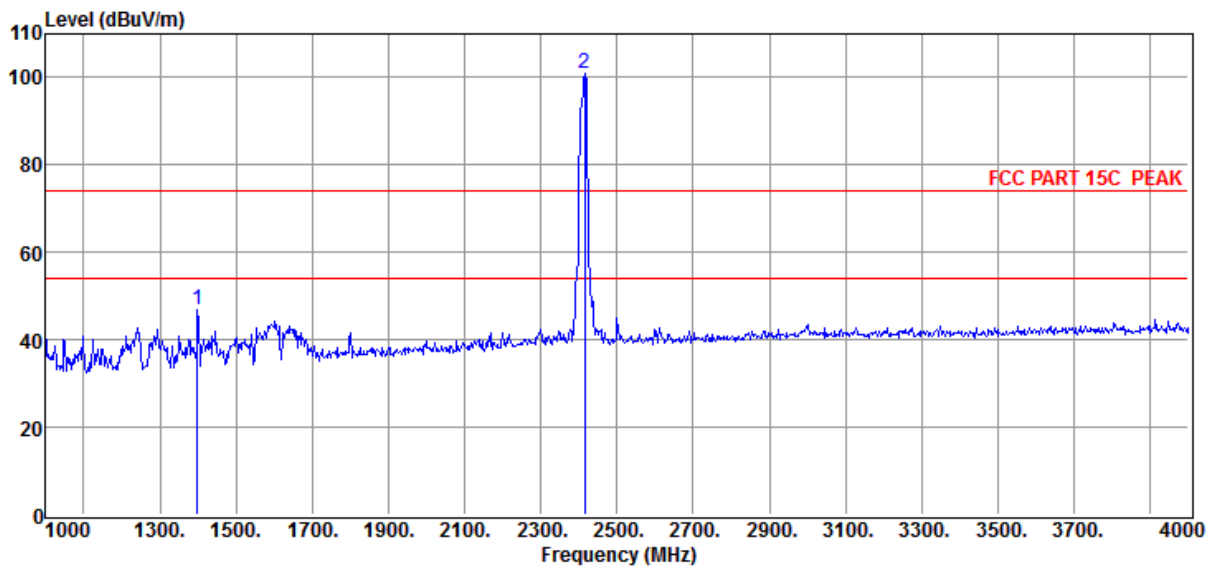

Item (Mark)	Freq (MHz)	Read Level (dBμV)	Antenna Factor (dB/m)	PRM Factor dB	Cable Loss dB	Result Level (dBμV/m)	Limit Line (dBμV/m)	Over Limit (dB)	Detector	Polarization
1	1399.00	57.64	25.95	43.29	6.42	46.72	74.00	-27.28	Peak	HORIZONTAL
2	2416.00	106.01	30.04	43.49	8.35	100.91	74.00	26.91	Peak	HORIZONTAL

- Note: 1. Result Level = Read Level + Antenna Factor + Cable loss - PRM Factor.
 2. If Peak Result complies with AV limit, AV Result is deemed to comply with AV limit.
 3. Test setup: RBW: 1 MHz, VBW: 3 MHz, Sweep time: auto.

TR-4-E-009 Radiated Emission Test Result

Test Site : DDT 3m Chamber	E:\2014 Report Data\hongjirui\RF.EM6
Test Date : 2014-08-31	Tested By : Leo
EUT : Turning	Model Number : RRAP-01
Power Supply : AC 120V/60Hz	Test Mode : Tx mode 11g CH1
Condition : Temp:24.5'C,Humi:55%, Press:100.1kPa	Antenna/Distance : 2013 HF907/3m/VERTICAL
Memo :	

Data: 14

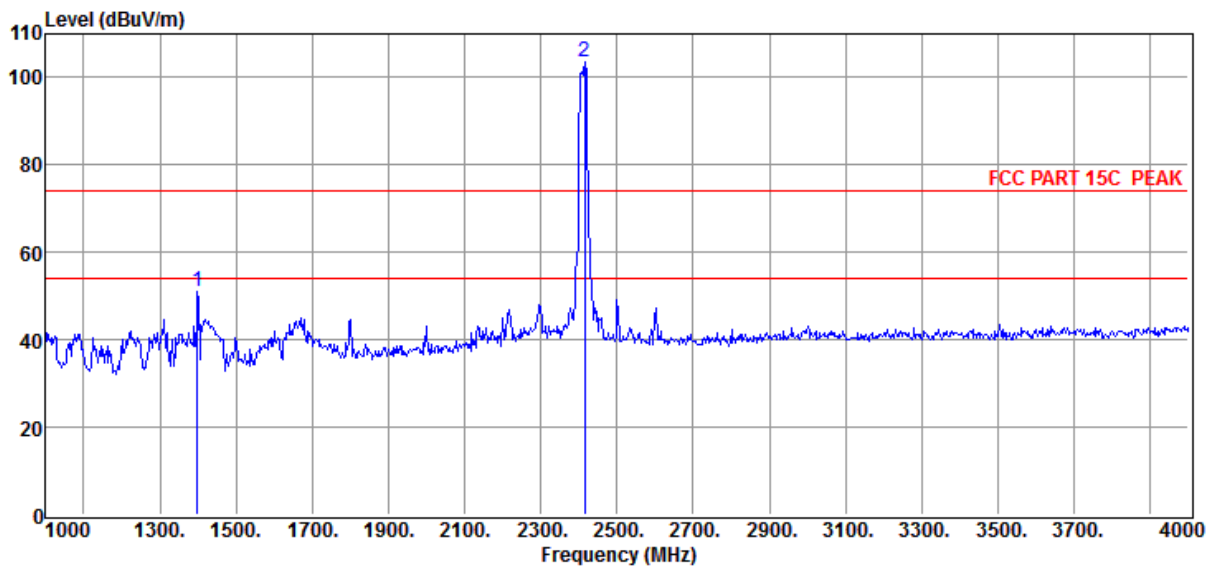

Item (Mark)	Freq (MHz)	Read Level (dBμV)	Antenna Factor (dB/m)	PRM Factor dB	Cable Loss dB	Result Level (dBμV/m)	Limit Line (dBμV/m)	Over Limit (dB)	Detector	Polarization
1	1399.00	62.10	25.95	43.29	6.42	51.18	74.00	-22.82	Peak	VERTICAL
2	2416.00	108.52	30.04	43.49	8.35	103.42	74.00	29.42	Peak	VERTICAL

- Note: 1. Result Level = Read Level + Antenna Factor + Cable loss - PRM Factor.
 2. If Peak Result complies with AV limit, AV Result is deemed to comply with AV limit.
 3. Test setup: RBW: 1 MHz, VBW: 3 MHz, Sweep time: auto.

TR-4-E-009 Radiated Emission Test Result

Test Site	: DDT 3m Chamber	E:\2014 Report Data\hongjirui\RF.EM6
Test Date	: 2014-08-31	Tested By : Leo
EUT	: Turning	Model Number : RRAP-01
Power Supply	: AC 120V/60Hz	Test Mode : Tx mode 11g CH6
Condition	: Temp:24.5'C,Humi:55%, Press:100.1kPa	Antenna/Distance : 2013 HF907/3m/VERTICAL
Memo	:	

Data: 15

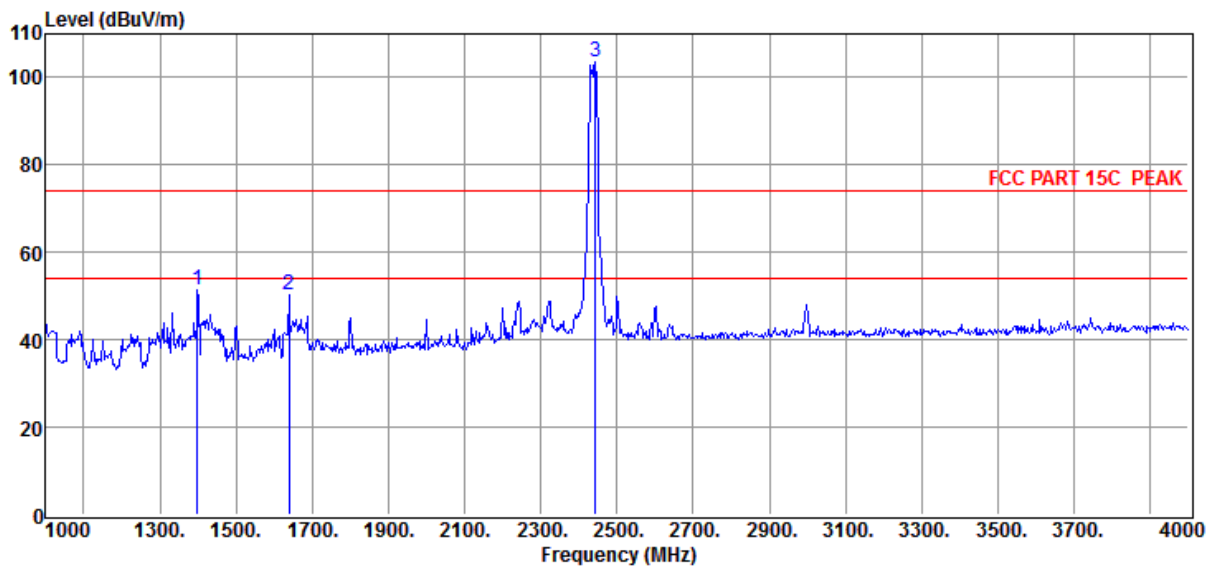

Item (Mark)	Freq (MHz)	Read Level (dBμV)	Antenna Factor (dB/m)	PRM Factor dB	Cable Loss dB	Result Level (dBμV/m)	Limit Line (dBμV/m)	Over Limit (dB)	Detector	Polarization
1	1399.00	62.52	25.95	43.29	6.42	51.60	74.00	-22.40	Peak	VERTICAL
2	1639.00	59.75	27.05	43.34	6.93	50.39	74.00	-23.61	Peak	VERTICAL
3	2443.00	108.63	30.14	43.49	8.40	103.68	74.00	29.68	Peak	VERTICAL

Note: 1. Result Level = Read Level + Antenna Factor + Cable loss - PRM Factor.
 2. If Peak Result complies with AV limit, AV Result is deemed to comply with AV limit.
 3. Test setup: RBW: 1 MHz, VBW: 3 MHz, Sweep time: auto.

TR-4-E-009 Radiated Emission Test Result

Test Site : DDT 3m Chamber	E:\2014 Report Data\hongjirui\RF.EM6
Test Date : 2014-08-31	Tested By : Leo
EUT : Turning	Model Number : RRAP-01
Power Supply : AC 120V/60Hz	Test Mode : Tx mode 11g CH6
Condition : Temp:24.5'C,Humi:55%, Press:100.1kPa	Antenna/Distance : 2013 HF907/3m/HORIZONTAL
Memo :	

Data: 16

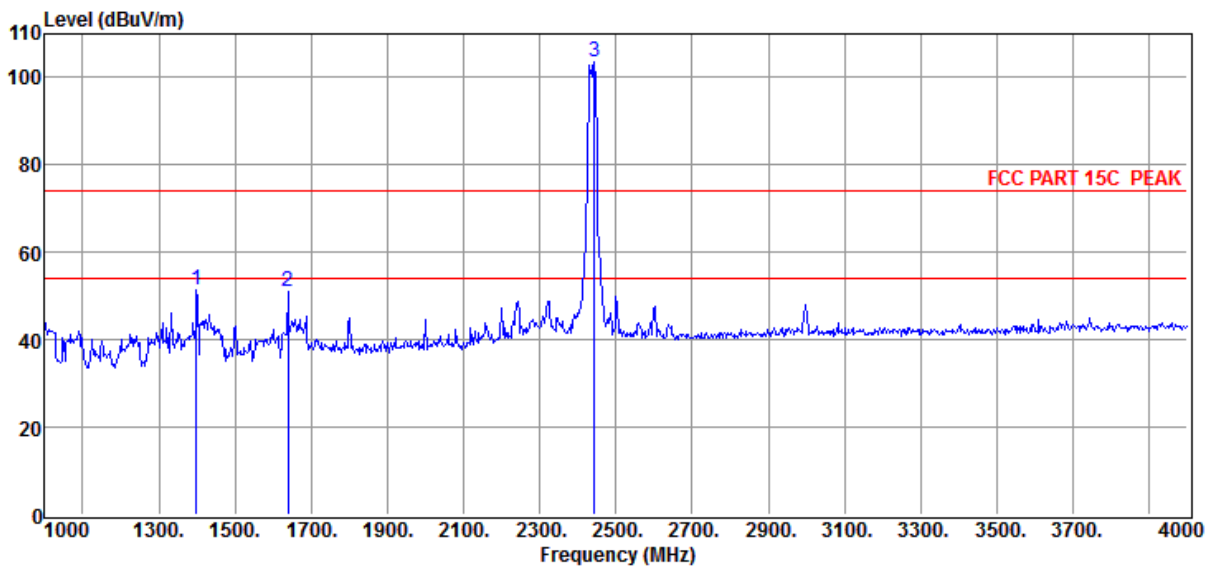

Item (Mark)	Freq (MHz)	Read Level (dBμV)	Antenna Factor (dB/m)	PRM Factor dB	Cable Loss dB	Result Level (dBμV/m)	Limit Line (dBμV/m)	Over Limit (dB)	Detector	Polarization
1	1399.00	62.52	25.95	43.29	6.42	51.60	74.00	-22.40	Peak	HORIZONTAL
2	1639.00	60.31	27.05	43.34	6.93	50.95	74.00	-23.05	Peak	HORIZONTAL
3	2443.00	108.63	30.14	43.49	8.40	103.68	74.00	29.68	Peak	HORIZONTAL

Note: 1. Result Level = Read Level + Antenna Factor + Cable loss - PRM Factor.
 2. If Peak Result complies with AV limit, AV Result is deemed to comply with AV limit.
 3. Test setup: RBW: 1 MHz, VBW: 3 MHz, Sweep time: auto.

TR-4-E-009 Radiated Emission Test Result

Test Site	: DDT 3m Chamber	E:\2014 Report Data\hongjirui\RF.EM6
Test Date	: 2014-08-31	Tested By : Leo
EUT	: Turning	Model Number : RRAP-01
Power Supply	: AC 120V/60Hz	Test Mode : Tx mode 11g CH11
Condition	: Temp:24.5'C,Humi:55%, Press:100.1kPa	Antenna/Distance : 2013 HF907/3m/HORIZONTAL
Memo	:	

Data: 17

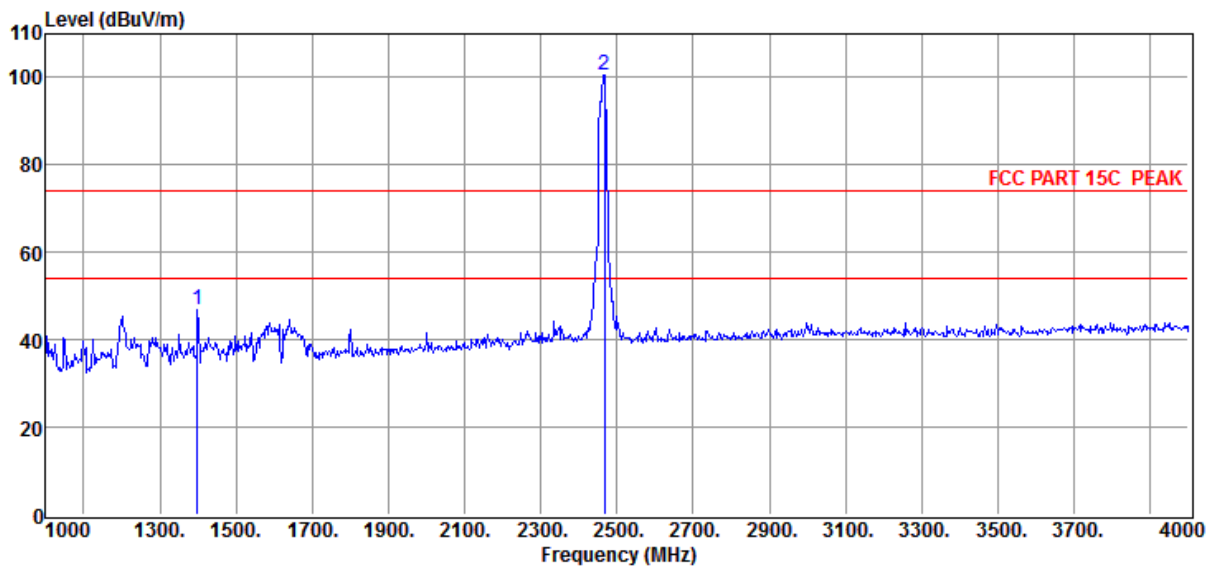

Item (Mark)	Freq (MHz)	Read Level (dBμV)	Antenna Factor (dB/m)	PRM Factor dB	Cable Loss dB	Result Level (dBμV/m)	Limit Line (dBμV/m)	Over Limit (dB)	Detector	Polarization
1	1399.00	57.98	25.95	43.29	6.42	47.06	74.00	-26.94	Peak	HORIZONTAL
2	2467.00	105.42	30.20	43.49	8.45	100.58	74.00	26.58	Peak	HORIZONTAL

- Note: 1. Result Level = Read Level + Antenna Factor + Cable loss - PRM Factor.
 2. If Peak Result complies with AV limit, AV Result is deemed to comply with AV limit.
 3. Test setup: RBW: 1 MHz, VBW: 3 MHz, Sweep time: auto.

TR-4-E-009 Radiated Emission Test Result

Test Site	: DDT 3m Chamber	E:\2014 Report Data\hongjirui\RF.EM6
Test Date	: 2014-08-31	Tested By : Leo
EUT	: Turning	Model Number : RRAP-01
Power Supply	: AC 120V/60Hz	Test Mode : Tx mode 11g CH11
Condition	: Temp:24.5'C,Humi:55%, Press:100.1kPa	Antenna/Distance : 2013 HF907/3m/VERTICAL
Memo	:	

Data: 18

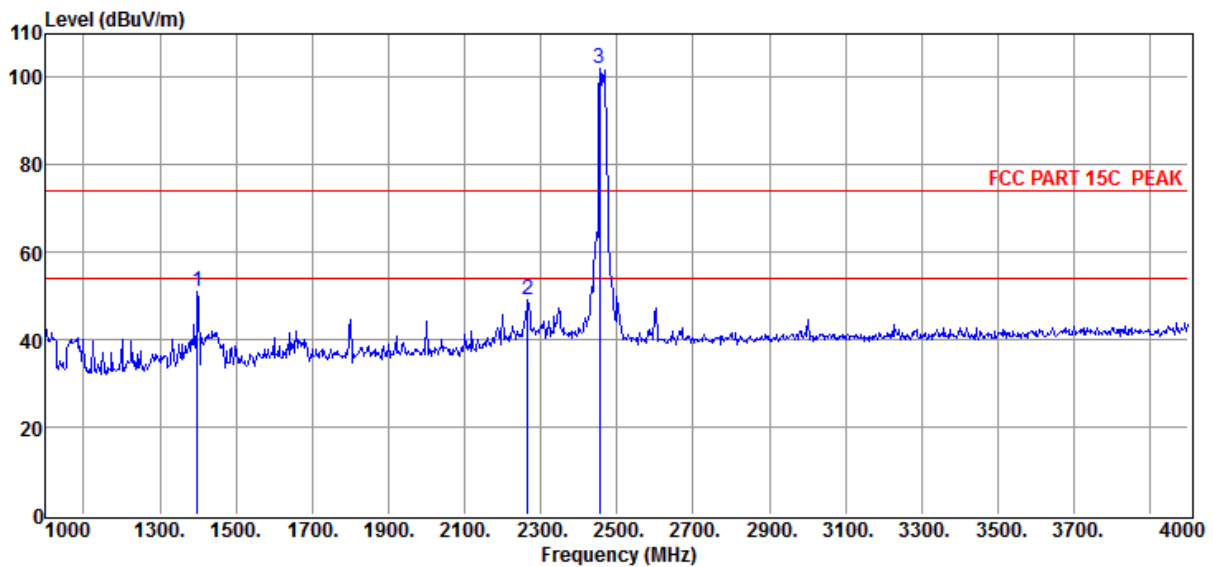

Item (Mark)	Freq (MHz)	Read Level (dBμV)	Antenna Factor (dB/m)	PRM Factor dB	Cable Loss dB	Result Level (dBμV/m)	Limit Line (dBμV/m)	Over Limit (dB)	Detector	Polarization
1	1399.00	62.08	25.95	43.29	6.42	51.16	74.00	-22.84	Peak	VERTICAL
2	2266.00	54.73	29.58	43.45	8.10	48.96	74.00	-25.04	Peak	VERTICAL
3	2455.00	106.95	30.20	43.49	8.45	102.11	74.00	28.11	Peak	VERTICAL

Note: 1. Result Level = Read Level + Antenna Factor + Cable loss - PRM Factor.
 2. If Peak Result complies with AV limit, AV Result is deemed to comply with AV limit.
 3. Test setup: RBW: 1 MHz, VBW: 3 MHz, Sweep time: auto.

TR-4-E-009 Radiated Emission Test Result

Test Site : DDT 3m Chamber E:\2014 Report Data\hongjirui\RF.EM6
Test Date : 2014-08-31 **Tested By** : Leo
EUT : Turning **Model Number** : RRAP-01
Power Supply : AC 120V/60Hz **Test Mode** : Tx mode 11n HT20 CH1
Condition : Temp:24.5'C,Humi:55%,
 Press:100.1kPa **Antenna/Distance** : 2013 HF907/3m/VERTICAL
Memo :

Data: 23

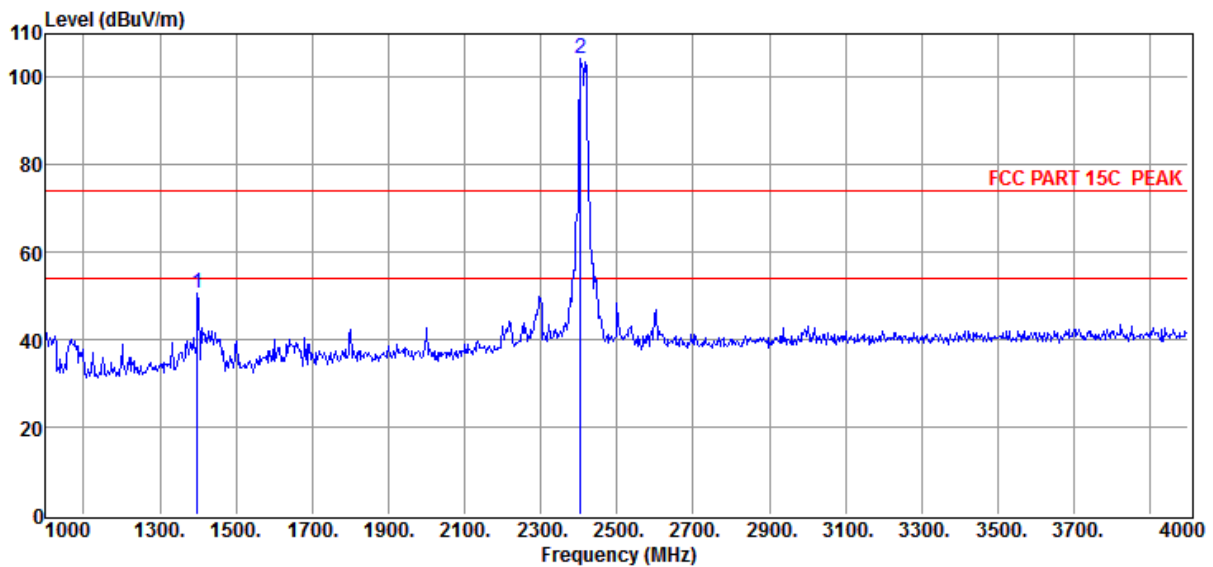

Item (Mark)	Freq (MHz)	Read Level (dBμV)	Antenna Factor (dB/m)	PRM Factor dB	Cable Loss dB	Result Level (dBμV/m)	Limit Line (dBμV/m)	Over Limit (dB)	Detector	Polarization
1	1399.00	61.69	25.95	43.29	6.42	50.77	74.00	-23.23	Peak	VERTICAL
2	2404.00	109.49	30.04	43.49	8.35	104.39	74.00	30.39	Peak	VERTICAL

Note: 1. Result Level = Read Level + Antenna Factor + Cable loss - PRM Factor.
 2. If Peak Result complies with AV limit, AV Result is deemed to comply with AV limit.
 3. Test setup: RBW: 1 MHz, VBW: 3 MHz, Sweep time: auto.

TR-4-E-009 Radiated Emission Test Result

Test Site	: DDT 3m Chamber	E:\2014 Report Data\hongjirui\RF.EM6
Test Date	: 2014-08-31	Tested By : Leo
EUT	: Turning	Model Number : RRAP-01
Power Supply	: AC 120V/60Hz	Test Mode : Tx mode 11n HT20 CH1
Condition	: Temp:24.5'C,Humi:55%, Press:100.1kPa	Antenna/Distance : 2013 HF907/3m/HORIZONTAL
Memo	:	

Data: 24

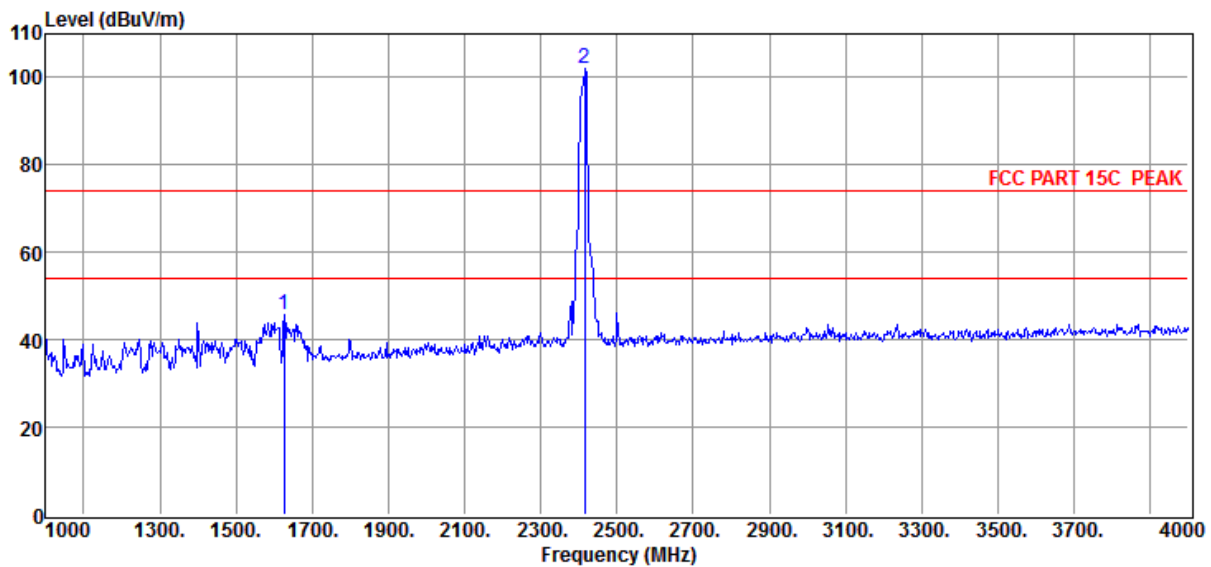

Item (Mark)	Freq (MHz)	Read Level (dBμV)	Antenna Factor (dB/m)	PRM Factor dB	Cable Loss dB	Result Level (dBμV/m)	Limit Line (dBμV/m)	Over Limit (dB)	Detector	Polarization
1	1627.00	55.14	26.97	43.34	6.89	45.66	74.00	-28.34	Peak	HORIZONTAL
2	2416.00	107.03	30.04	43.49	8.35	101.93	74.00	27.93	Peak	HORIZONTAL

- Note: 1. Result Level = Read Level + Antenna Factor + Cable loss - PRM Factor.
 2. If Peak Result complies with AV limit, AV Result is deemed to comply with AV limit.
 3. Test setup: RBW: 1 MHz, VBW: 3 MHz, Sweep time: auto.

TR-4-E-009 Radiated Emission Test Result

Test Site	: DDT 3m Chamber	E:\2014 Report Data\hongjirui\RF.EM6
Test Date	: 2014-08-31	Tested By : Leo
EUT	: Turning	Model Number : RRAP-01
Power Supply	: AC 120V/60Hz	Test Mode : Tx mode 11n HT20 CH6
Condition	: Temp:24.5'C,Humi:55%, Press:100.1kPa	Antenna/Distance : 2013 HF907/3m/HORIZONTAL
Memo	:	

Data: 25

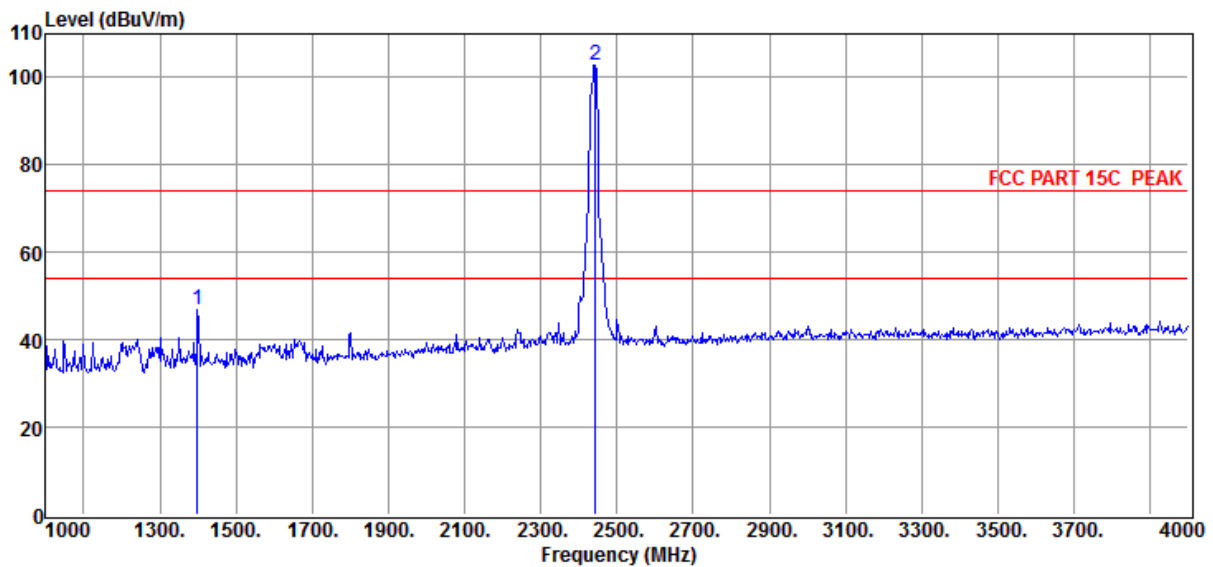

Item (Mark)	Freq (MHz)	Read Level (dBμV)	Antenna Factor (dB/m)	PRM Factor dB	Cable Loss dB	Result Level (dBμV/m)	Limit Line (dBμV/m)	Over Limit (dB)	Detector	Polarization
1	1399.00	57.69	25.95	43.29	6.42	46.77	74.00	-27.23	Peak	HORIZONTAL
2	2443.00	107.78	30.14	43.49	8.40	102.83	74.00	28.83	Peak	HORIZONTAL

- Note: 1. Result Level = Read Level + Antenna Factor + Cable loss - PRM Factor.
 2. If Peak Result complies with AV limit, AV Result is deemed to comply with AV limit.
 3. Test setup: RBW: 1 MHz, VBW: 3 MHz, Sweep time: auto.

TR-4-E-009 Radiated Emission Test Result

Test Site	: DDT 3m Chamber	E:	E:\2014 Report Data\hongjirui\RF.EM6
Test Date	: 2014-08-31	Tested By	: Leo
EUT	: Turning	Model Number	: RRAP-01
Power Supply	: AC 120V/60Hz	Test Mode	: Tx mode 11n HT20 CH6
Condition	: Temp:24.5'C,Humi:55%, Press:100.1kPa	Antenna/Distance	: 2013 HF907/3m/VERTICAL
Memo	:		

Data: 26

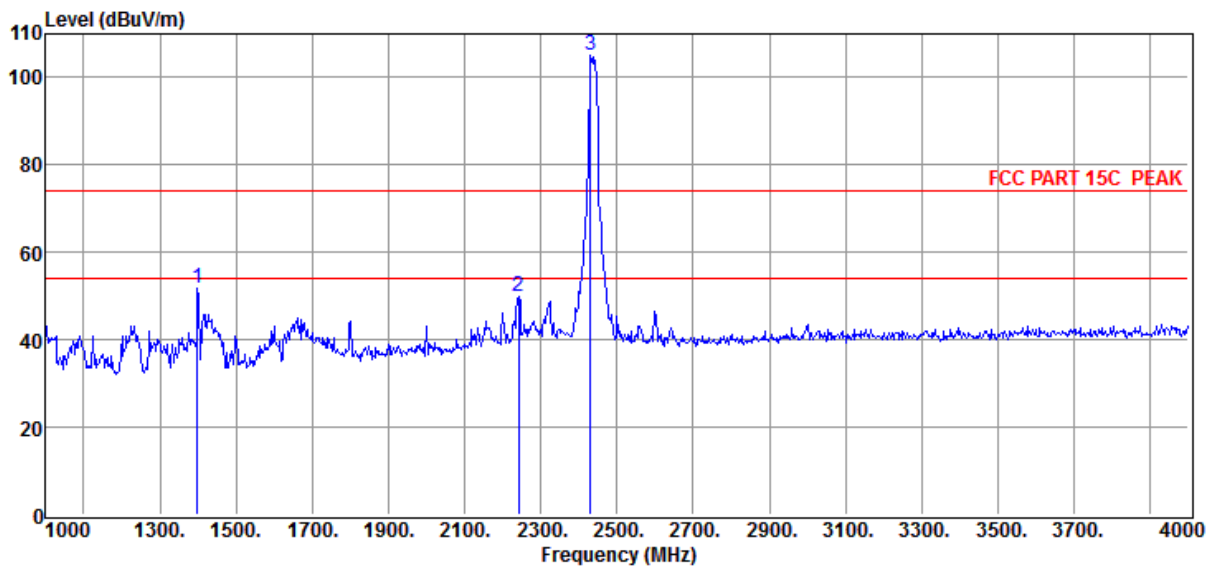

Item (Mark)	Freq (MHz)	Read Level (dBμV)	Antenna Factor (dB/m)	PRM Factor dB	Cable Loss dB	Result Level (dBμV/m)	Limit Line (dBμV/m)	Over Limit (dB)	Detector	Polarization
1	1399.00	62.54	25.95	43.29	6.42	51.62	74.00	-22.38	Peak	VERTICAL
2	2242.00	55.67	29.52	43.45	8.05	49.79	74.00	-24.21	Peak	VERTICAL
3	2431.00	110.20	30.09	43.49	8.40	105.20	74.00	31.20	Peak	VERTICAL

Note: 1. Result Level = Read Level + Antenna Factor + Cable loss - PRM Factor.
 2. If Peak Result complies with AV limit, AV Result is deemed to comply with AV limit.
 3. Test setup: RBW: 1 MHz, VBW: 3 MHz, Sweep time: auto.

TR-4-E-009 Radiated Emission Test Result

Test Site	: DDT 3m Chamber	E:\2014 Report Data\hongjirui\RF.EM6
Test Date	: 2014-08-31	Tested By : Leo
EUT	: Turning	Model Number : RRAP-01
Power Supply	: AC 120V/60Hz	Test Mode : Tx mode 11n HT20 CH11
Condition	: Temp:24.5'C,Humi:55%, Press:100.1kPa	Antenna/Distance : 2013 HF907/3m/VERTICAL
Memo	:	

Data: 27

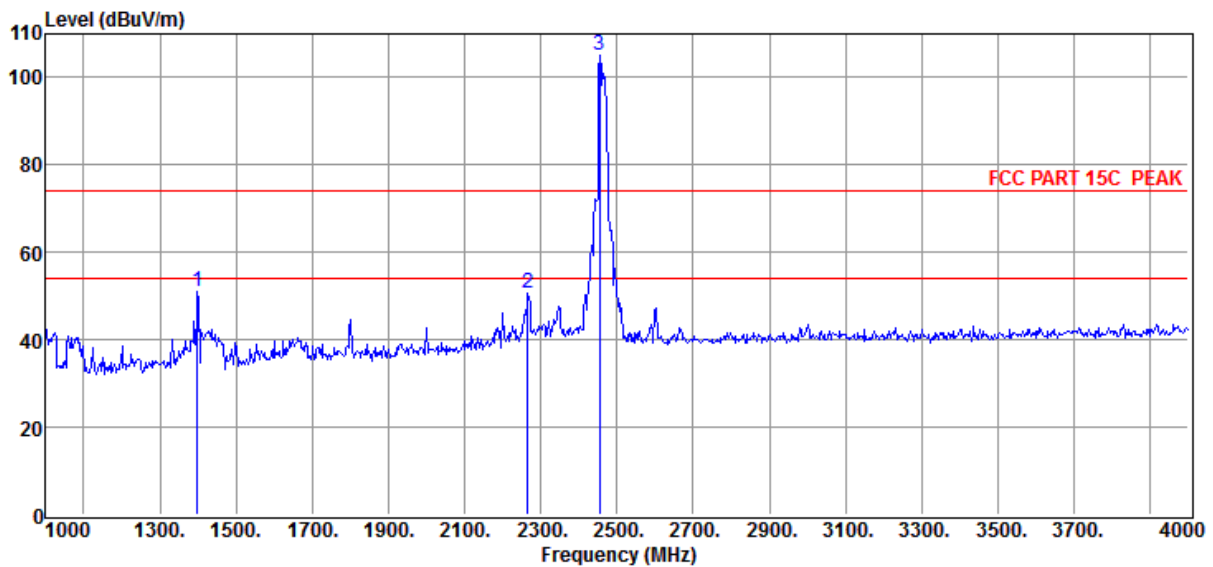

Item (Mark)	Freq (MHz)	Read Level (dBμV)	Antenna Factor (dB/m)	PRM Factor dB	Cable Loss dB	Result Level (dBμV/m)	Limit Line (dBμV/m)	Over Limit (dB)	Detector	Polarization
1	1399.00	61.85	25.95	43.29	6.42	50.93	74.00	-23.07	Peak	VERTICAL
2	2266.00	56.61	29.58	43.45	8.10	50.84	74.00	-23.16	Peak	VERTICAL
3	2455.00	109.76	30.20	43.49	8.45	104.92	74.00	30.92	Peak	VERTICAL

Note: 1. Result Level = Read Level + Antenna Factor + Cable loss - PRM Factor.
 2. If Peak Result complies with AV limit, AV Result is deemed to comply with AV limit.
 3. Test setup: RBW: 1 MHz, VBW: 3 MHz, Sweep time: auto.

TR-4-E-009 Radiated Emission Test Result

Test Site	: DDT 3m Chamber	E:\2014 Report Data\hongjirui\RF.EM6
Test Date	: 2014-08-31	Tested By : Leo
EUT	: Turning	Model Number : RRAP-01
Power Supply	: AC 120V/60Hz	Test Mode : Tx mode 11n HT20 CH11
Condition	: Temp:24.5'C,Humi:55%, Press:100.1kPa	Antenna/Distance : 2013 HF907/3m/HORIZONTAL
Memo	:	

Data: 28

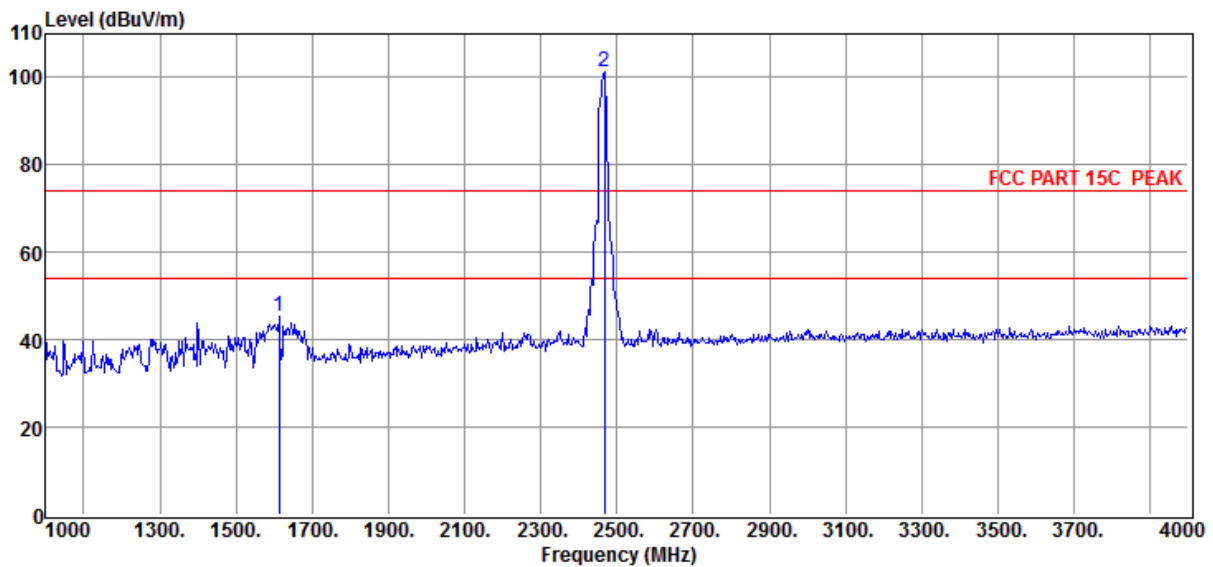

Item (Mark)	Freq (MHz)	Read Level (dBμV)	Antenna Factor (dB/m)	PRM Factor dB	Cable Loss dB	Result Level (dBμV/m)	Limit Line (dBμV/m)	Over Limit (dB)	Detector	Polarization
1	1612.00	55.04	26.88	43.34	6.85	45.43	74.00	-28.57	Peak	HORIZONTAL
2	2467.00	106.05	30.20	43.49	8.45	101.21	74.00	27.21	Peak	HORIZONTAL

- Note: 1. Result Level = Read Level + Antenna Factor + Cable loss - PRM Factor.
 2. If Peak Result complies with AV limit, AV Result is deemed to comply with AV limit.
 3. Test setup: RBW: 1 MHz, VBW: 3 MHz, Sweep time: auto.

TR-4-E-009 Radiated Emission Test Result

Test Site	: DDT 3m Chamber	E:\2014 Report Data\hongjirui\RF.EM6
Test Date	: 2014-08-31	Tested By : Leo
EUT	: Turning	Model Number : RRAP-01
Power Supply	: AC 120V/60Hz	Test Mode : Tx mode 11n HT40 CH3
Condition	: Temp:24.5'C,Humi:55%, Press:100.1kPa	Antenna/Distance : 2013 HF907/3m/HORIZONTAL
Memo	:	

Data: 33

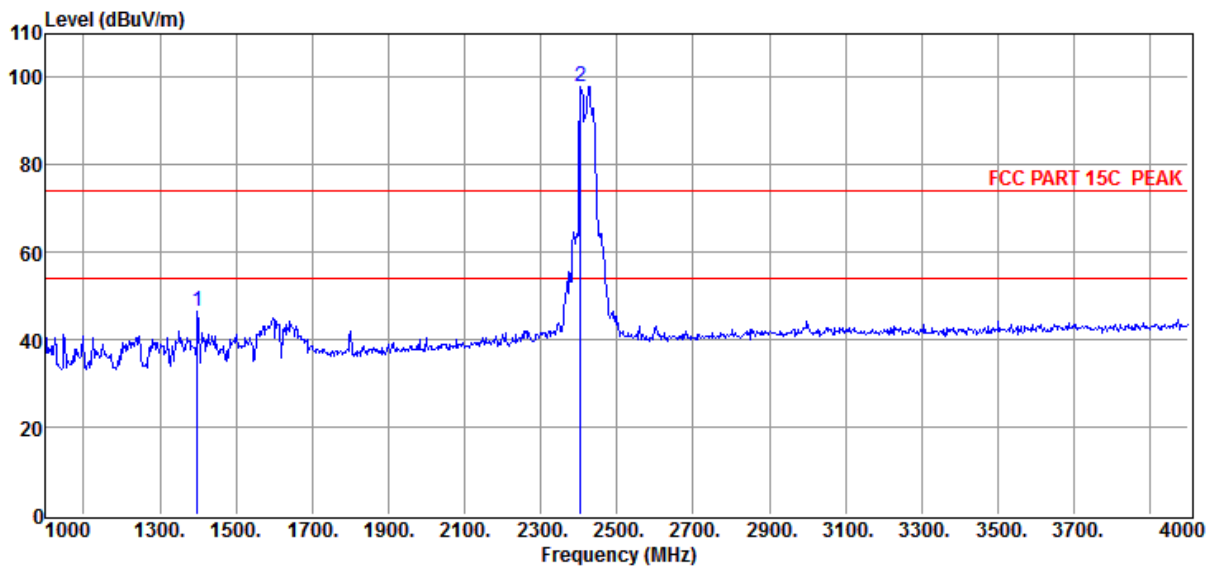

Item (Mark)	Freq (MHz)	Read Level (dBμV)	Antenna Factor (dB/m)	PRM Factor dB	Cable Loss dB	Result Level (dBμV/m)	Limit Line (dBμV/m)	Over Limit (dB)	Detector	Polarization
1	1399.00	57.58	25.95	43.29	6.42	46.66	74.00	-27.34	Peak	HORIZONTAL
2	2404.00	103.15	30.04	43.49	8.35	98.05	74.00	24.05	Peak	HORIZONTAL

- Note: 1. Result Level = Read Level + Antenna Factor + Cable loss - PRM Factor.
 2. If Peak Result complies with AV limit, AV Result is deemed to comply with AV limit.
 3. Test setup: RBW: 1 MHz, VBW: 3 MHz, Sweep time: auto.

TR-4-E-009 Radiated Emission Test Result

Test Site : DDT 3m Chamber	E:\2014 Report Data\hongjirui\RF.EM6
Test Date : 2014-08-31	Tested By : Leo
EUT : Turning	Model Number : RRAP-01
Power Supply : AC 120V/60Hz	Test Mode : Tx mode 11n HT40 CH3
Condition : Temp:24.5'C,Humi:55%, Press:100.1kPa	Antenna/Distance : 2013 HF907/3m/VERTICAL
Memo :	

Data: 34

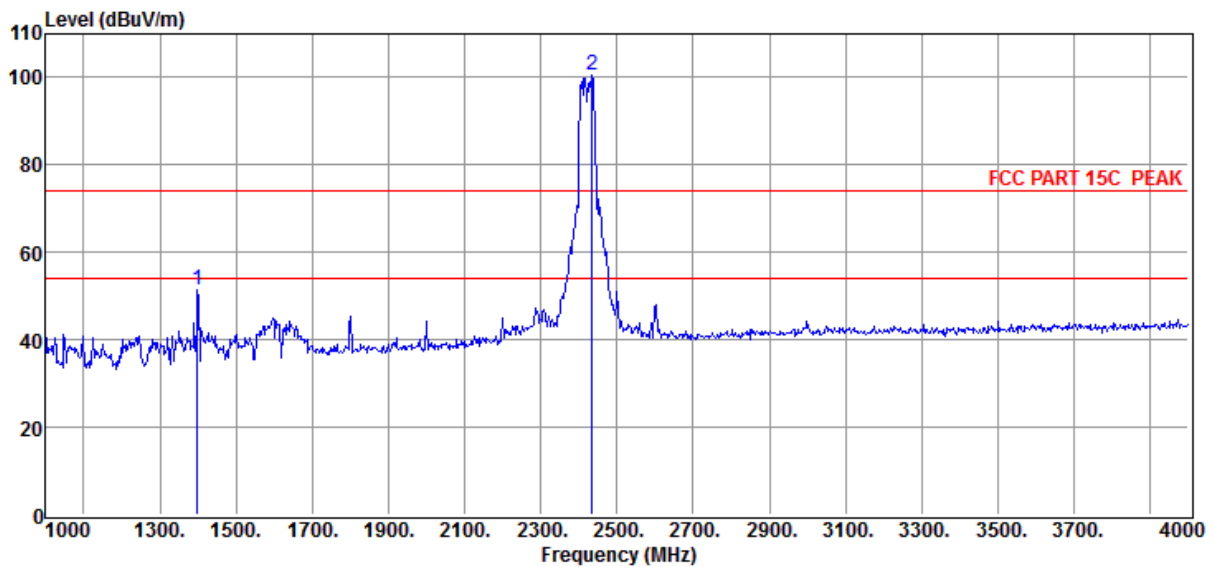

Item (Mark)	Freq (MHz)	Read Level (dBμV)	Antenna Factor (dB/m)	PRM Factor dB	Cable Loss dB	Result Level (dBμV/m)	Limit Line (dBμV/m)	Over Limit (dB)	Detector	Polarization
1	1399.00	62.19	25.95	43.29	6.42	51.27	74.00	-22.73	Peak	VERTICAL
2	2434.00	105.62	30.09	43.49	8.40	100.62	74.00	26.62	Peak	VERTICAL

- Note: 1. Result Level = Read Level + Antenna Factor + Cable loss - PRM Factor.
 2. If Peak Result complies with AV limit, AV Result is deemed to comply with AV limit.
 3. Test setup: RBW: 1 MHz, VBW: 3 MHz, Sweep time: auto.

TR-4-E-009 Radiated Emission Test Result

Test Site : DDT 3m Chamber	E:\2014 Report Data\hongjirui\RF.EM6
Test Date : 2014-08-31	Tested By : Leo
EUT : Turning	Model Number : RRAP-01
Power Supply : AC 120V/60Hz	Test Mode : Tx mode 11n HT40 CH6
Condition : Temp:24.5'C,Humi:55%, Press:100.1kPa	Antenna/Distance : 2013 HF907/3m/VERTICAL
Memo :	

Data: 35

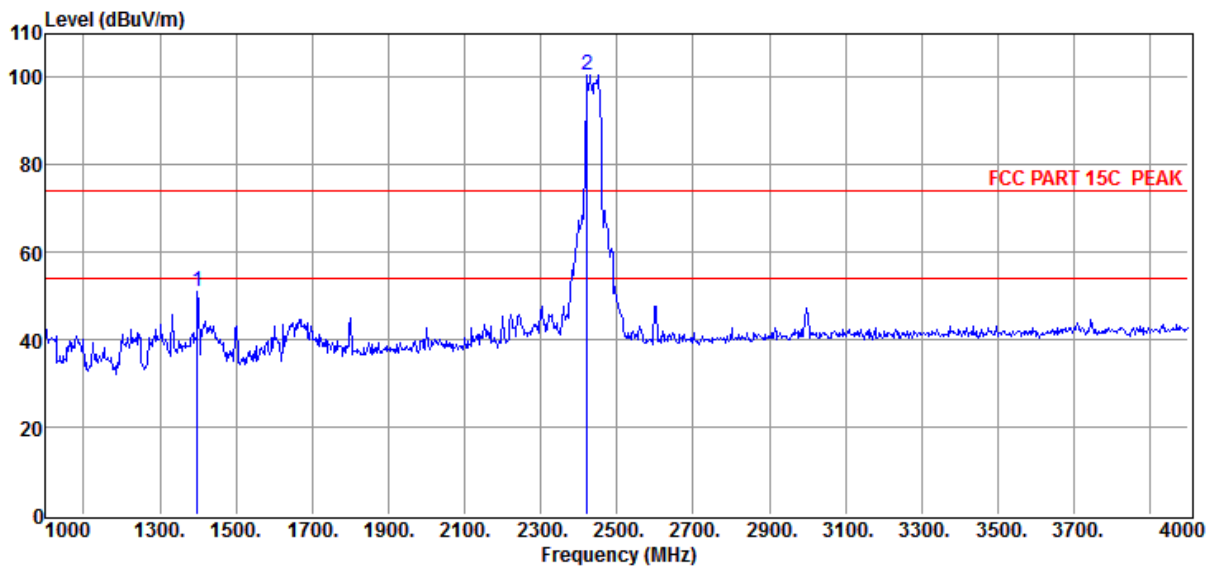

Item (Mark)	Freq (MHz)	Read Level (dBμV)	Antenna Factor (dB/m)	PRM Factor dB	Cable Loss dB	Result Level (dBμV/m)	Limit Line (dBμV/m)	Over Limit (dB)	Detector	Polarization
1	1399.00	62.07	25.95	43.29	6.42	51.15	74.00	-22.85	Peak	VERTICAL
2	2422.00	105.65	30.09	43.49	8.40	100.65	74.00	26.65	Peak	VERTICAL

- Note: 1. Result Level = Read Level + Antenna Factor + Cable loss - PRM Factor.
 2. If Peak Result complies with AV limit, AV Result is deemed to comply with AV limit.
 3. Test setup: RBW: 1 MHz, VBW: 3 MHz, Sweep time: auto.

TR-4-E-009 Radiated Emission Test Result

Test Site	: DDT 3m Chamber	E:\2014 Report Data\hongjirui\RF.EM6
Test Date	: 2014-08-31	Tested By : Leo
EUT	: Turning	Model Number : RRAP-01
Power Supply	: AC 120V/60Hz	Test Mode : Tx mode 11n HT40 CH6
Condition	: Temp:24.5'C,Humi:55%, Press:100.1kPa	Antenna/Distance : 2013 HF907/3m/HORIZONTAL
Memo	:	

Data: 36

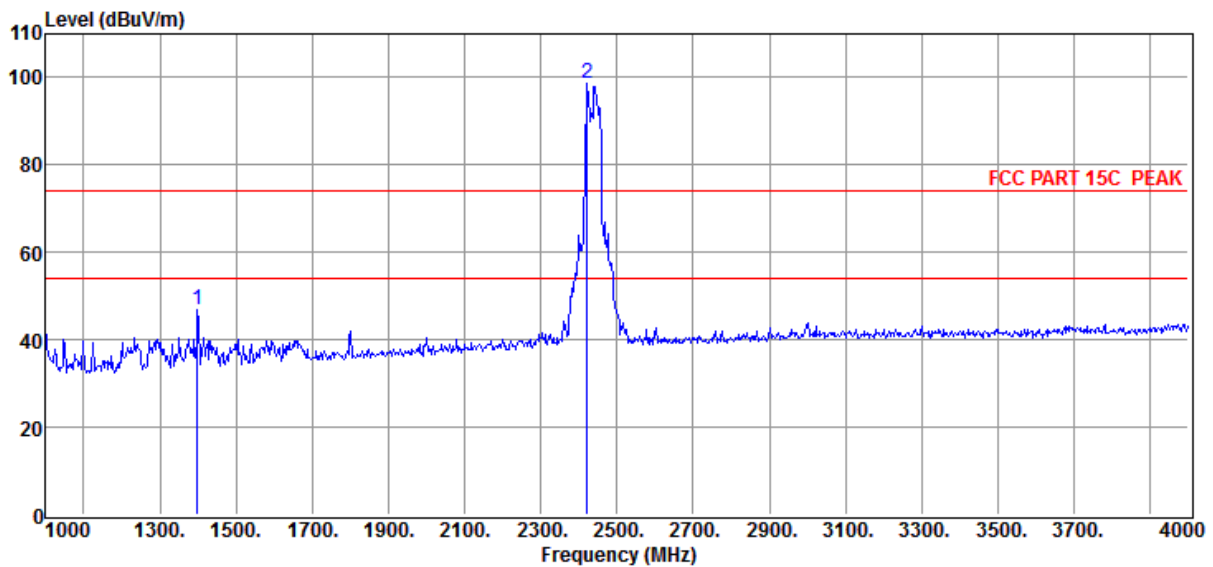

Item (Mark)	Freq (MHz)	Read Level (dBμV)	Antenna Factor (dB/m)	PRM Factor dB	Cable Loss dB	Result Level (dBμV/m)	Limit Line (dBμV/m)	Over Limit (dB)	Detector	Polarization
1	1399.00	57.63	25.95	43.29	6.42	46.71	74.00	-27.29	Peak	HORIZONTAL
2	2422.00	103.58	30.09	43.49	8.40	98.58	74.00	24.58	Peak	HORIZONTAL

- Note: 1. Result Level = Read Level + Antenna Factor + Cable loss - PRM Factor.
 2. If Peak Result complies with AV limit, AV Result is deemed to comply with AV limit.
 3. Test setup: RBW: 1 MHz, VBW: 3 MHz, Sweep time: auto.

TR-4-E-009 Radiated Emission Test Result

Test Site	: DDT 3m Chamber	E:\2014 Report Data\hongjirui\RF.EM6
Test Date	: 2014-08-31	Tested By : Leo
EUT	: Turning	Model Number : RRAP-01
Power Supply	: AC 120V/60Hz	Test Mode : Tx mode 11n HT40 CH9
Condition	: Temp:24.5'C,Humi:55%, Press:100.1kPa	Antenna/Distance : 2013 HF907/3m/HORIZONTAL
Memo	:	

Data: 37

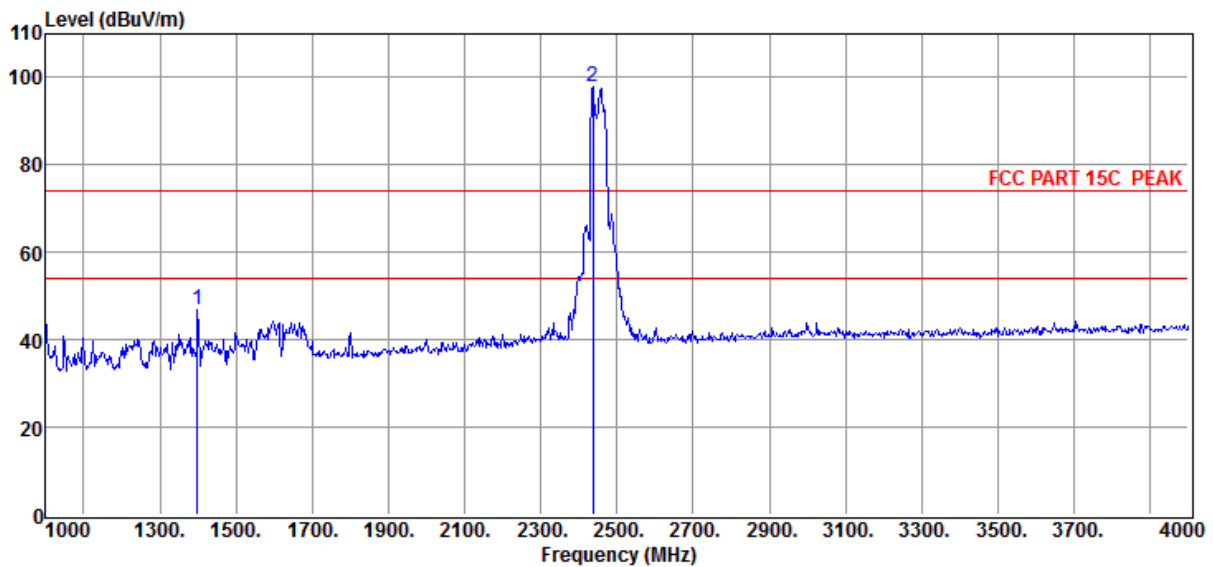

Item (Mark)	Freq (MHz)	Read Level (dBμV)	Antenna Factor (dB/m)	PRM Factor dB	Cable Loss dB	Result Level (dBμV/m)	Limit Line (dBμV/m)	Over Limit (dB)	Detector	Polarization
1	1399.00	57.92	25.95	43.29	6.42	47.00	74.00	-27.00	Peak	HORIZONTAL
2	2437.00	102.91	30.14	43.49	8.40	97.96	74.00	23.96	Peak	HORIZONTAL

- Note: 1. Result Level = Read Level + Antenna Factor + Cable loss - PRM Factor.
 2. If Peak Result complies with AV limit, AV Result is deemed to comply with AV limit.
 3. Test setup: RBW: 1 MHz, VBW: 3 MHz, Sweep time: auto.

TR-4-E-009 Radiated Emission Test Result

Test Site	: DDT 3m Chamber	E:\2014 Report Data\hongjirui\RF.EM6
Test Date	: 2014-08-31	Tested By : Leo
EUT	: Turning	Model Number : RRAP-01
Power Supply	: AC 120V/60Hz	Test Mode : Tx mode 11n HT40 CH9
Condition	: Temp:24.5'C,Humi:55%, Press:100.1kPa	Antenna/Distance : 2013 HF907/3m/VERTICAL
Memo	:	

Data: 38

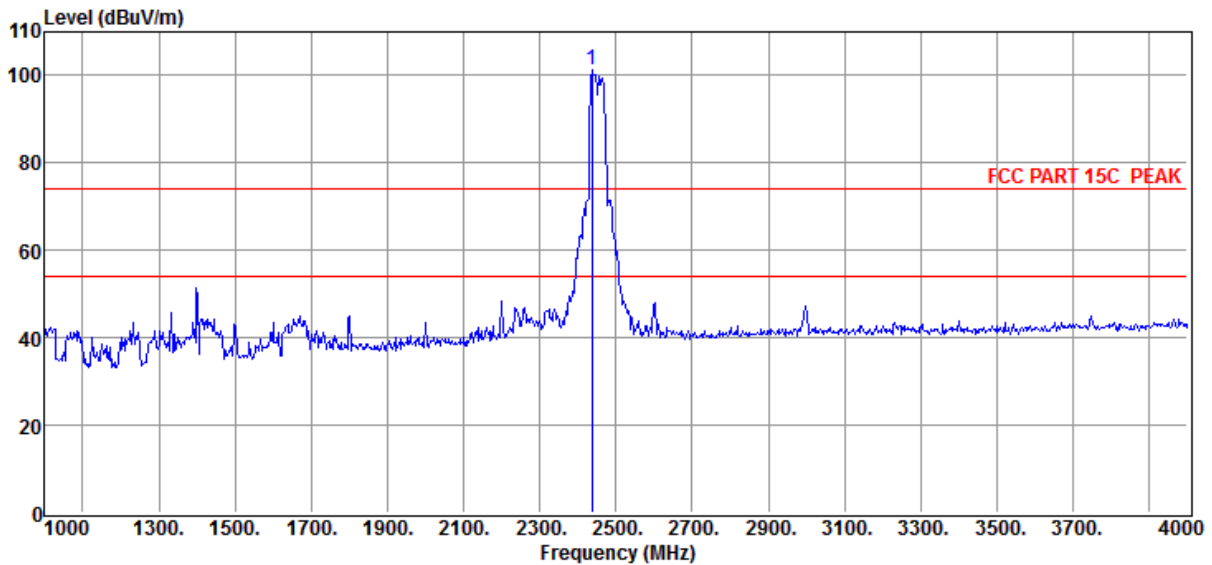

Item (Mark)	Freq (MHz)	Read Level (dBμV)	Antenna Factor (dB/m)	PRM Factor dB	Cable Loss dB	Result Level (dBμV/m)	Limit Line (dBμV/m)	Over Limit (dB)	Detector	Polarization
1	2437.00	106.38	30.14	43.49	8.40	101.43	74.00	27.43	Peak	VERTICAL

- Note: 1. Result Level = Read Level + Antenna Factor + Cable loss - PRM Factor.
 2. If Peak Result complies with AV limit, AV Result is deemed to comply with AV limit.
 3. Test setup: RBW: 1 MHz, VBW: 3 MHz, Sweep time: auto.

TR-4-E-009 Radiated Emission Test Result

Test Site : DDT 3m Chamber	E:\2014 Report Data\hongjirui\RF.EM6
Test Date : 2014-08-31	Tested By : Leo
EUT : Turning	Model Number : RRAP-01
Power Supply : AC 120V/60Hz	Test Mode : Tx mode 11b CH1
Condition : Temp:24.5'C,Humi:55%, Press:100.1kPa	Antenna/Distance : 2013 HF907/3m/VERTICAL
Memo :	

Data: 41

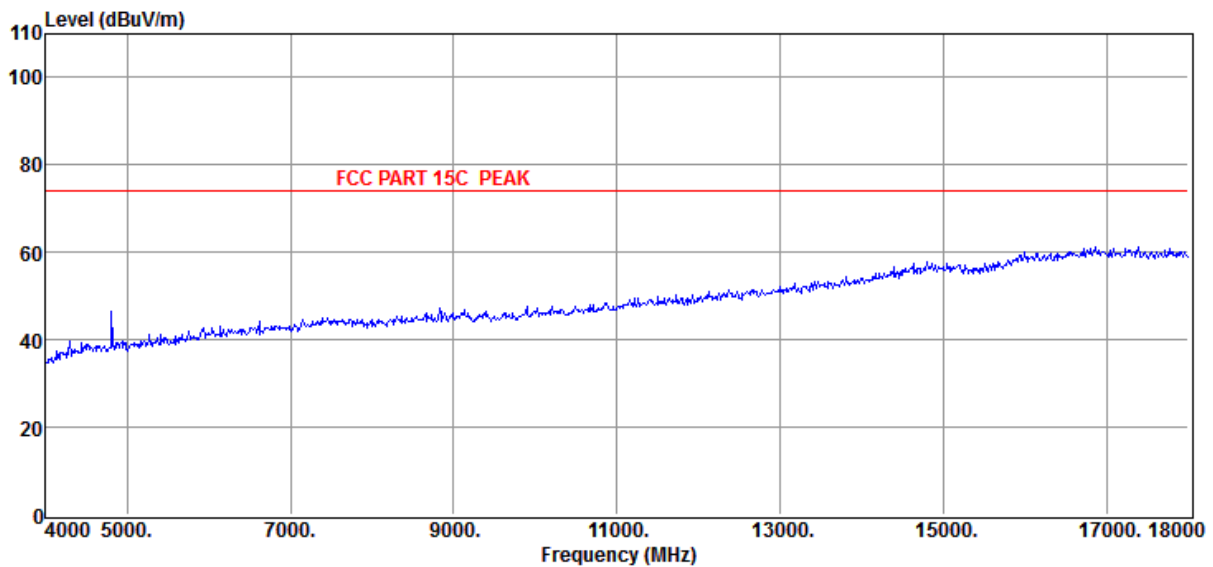

Item	Freq	Read Level	Antenna Factor	PRM Factor	Cable Loss	Result Level	Limit Line	Over Limit	Detector	Polarization
(Mark)	(MHz)	(dBμV)	(dB/m)	dB	dB	(dBμV/m)	(dBμV/m)	(dB)		

- Note: 1. Result Level = Read Level + Antenna Factor + Cable loss - PRM Factor.
 2. If Peak Result complies with AV limit, AV Result is deemed to comply with AV limit.
 3. Test setup: RBW: 1 MHz, VBW: 3 MHz, Sweep time: auto.

TR-4-E-009 Radiated Emission Test Result

Test Site : DDT 3m Chamber	E:\2014 Report Data\hongjirui\RF.EM6
Test Date : 2014-08-31	Tested By : Leo
EUT : Turning	Model Number : RRAP-01
Power Supply : AC 120V/60Hz	Test Mode : Tx mode 11b CH1
Condition : Temp:24.5'C,Humi:55%, Press:100.1kPa	Antenna/Distance : 2013 HF907/3m/VERTICAL
Memo :	

Data: 42

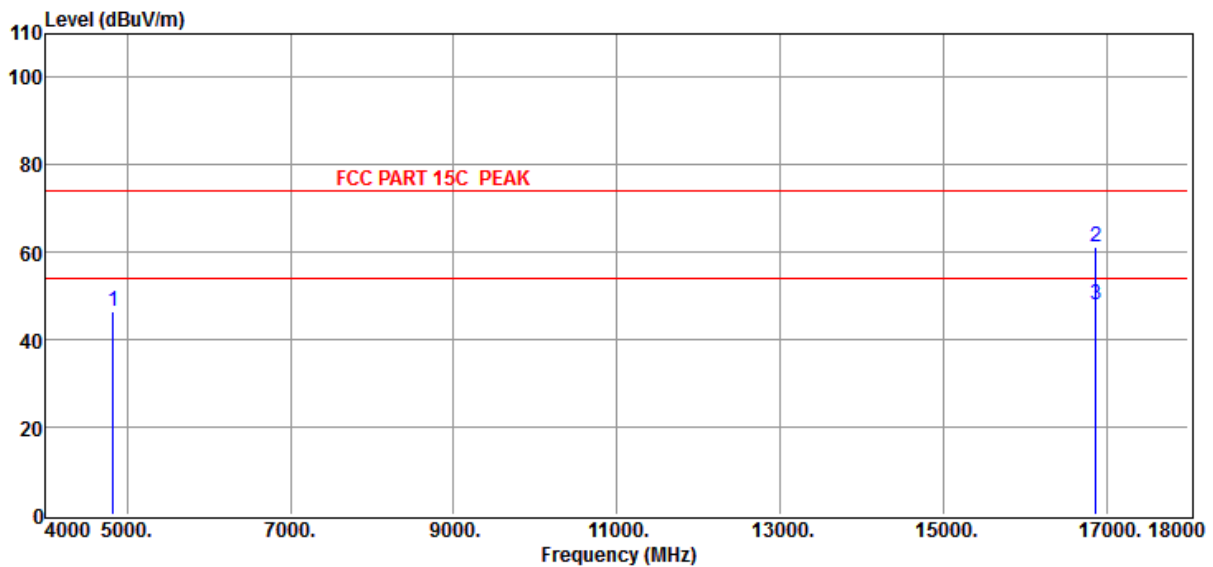

Item (Mark)	Freq (MHz)	Read Level (dBμV)	Antenna Factor (dB/m)	PRM Factor dB	Cable Loss dB	Result Level (dBμV/m)	Limit Line (dBμV/m)	Over Limit (dB)	Detector	Polarization
1	4824.00	42.92	35.42	44.06	12.07	46.35	74.00	-27.65	Peak	VERTICAL
2	16866.00	33.19	43.63	41.27	25.60	61.15	74.00	-12.85	Peak	VERTICAL
3	16866.00	20.13	43.63	41.27	25.60	48.09	54.00	-5.91	Average	VERTICAL

- Note: 1. Result Level = Read Level + Antenna Factor + Cable loss - PRM Factor.
 2. If Peak Result complies with AV limit, AV Result is deemed to comply with AV limit.
 3. Test setup: RBW: 1 MHz, VBW: 3 MHz, Sweep time: auto.

TR-4-E-009 Radiated Emission Test Result

Test Site : DDT 3m Chamber	E:\2014 Report Data\hongjirui\RF.EM6
Test Date : 2014-08-31	Tested By : Leo
EUT : Turning	Model Number : RRAP-01
Power Supply : AC 120V/60Hz	Test Mode : Tx mode 11b CH1
Condition : Temp:24.5'C,Humi:55%, Press:100.1kPa	Antenna/Distance : 2013 HF907/3m/HORIZONTAL
Memo :	

Data: 43

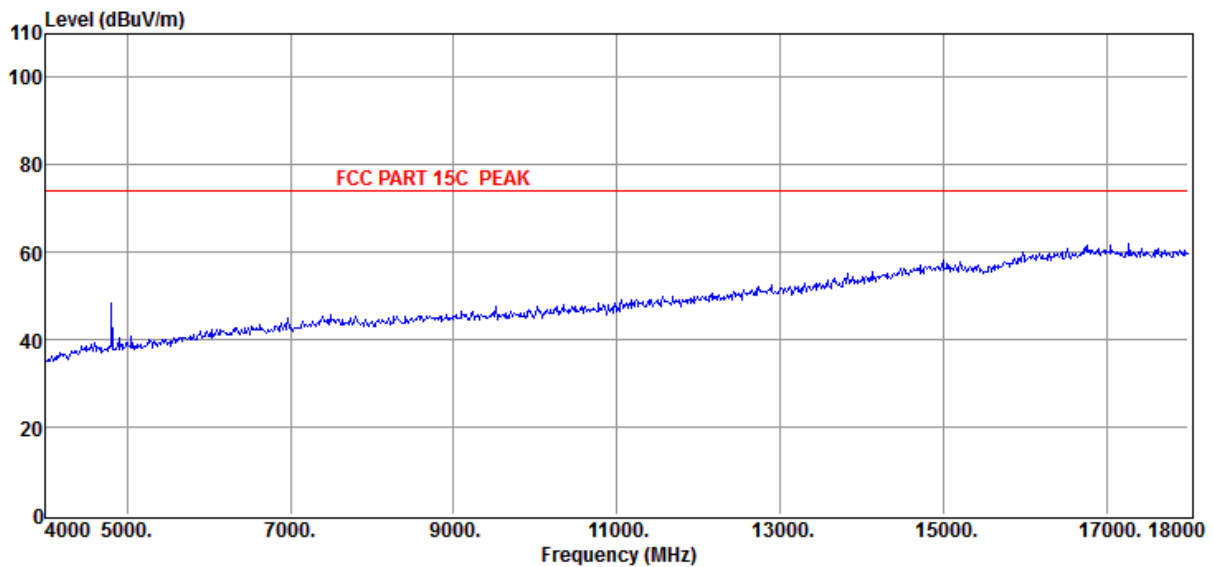

Item	Freq	Read Level	Antenna Factor	PRM Factor	Cable Loss	Result Level	Limit Line	Over Limit	Detector	Polarization
(Mark)	(MHz)	(dBμV)	(dB/m)	dB	dB	(dBμV/m)	(dBμV/m)	(dB)		

- Note: 1. Result Level = Read Level + Antenna Factor + Cable loss - PRM Factor.
 2. If Peak Result complies with AV limit, AV Result is deemed to comply with AV limit.
 3. Test setup: RBW: 1 MHz, VBW: 3 MHz, Sweep time: auto.

TR-4-E-009 Radiated Emission Test Result

Test Site	: DDT 3m Chamber	E:\2014 Report Data\hongjirui\RF.EM6
Test Date	: 2014-08-31	Tested By : Leo
EUT	: Turning	Model Number : RRAP-01
Power Supply	: AC 120V/60Hz	Test Mode : Tx mode 11b CH1
Condition	: Temp:24.5'C,Humi:55%, Press:100.1kPa	Antenna/Distance : 2013 HF907/3m/HORIZONTAL
Memo	:	

Data: 44

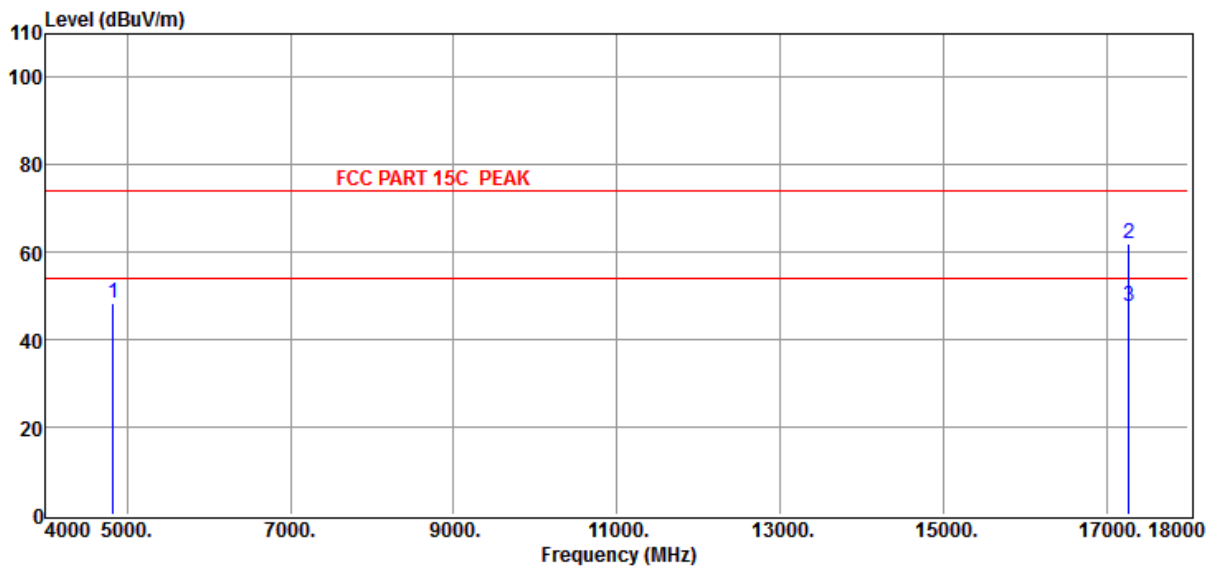

Item (Mark)	Freq (MHz)	Read Level (dBμV)	Antenna Factor (dB/m)	PRM Factor dB	Cable Loss dB	Result Level (dBμV/m)	Limit Line (dBμV/m)	Over Limit (dB)	Detector	Polarization
1	4824.00	44.98	35.42	44.06	12.07	48.41	74.00	-25.59	Peak	HORIZONTAL
2	17272.00	34.39	43.17	41.00	25.33	61.89	74.00	-12.11	Peak	HORIZONTAL
3	17272.00	20.15	43.17	41.00	25.33	47.65	54.00	-6.35	Average	HORIZONTAL

- Note: 1. Result Level = Read Level + Antenna Factor + Cable loss - PRM Factor.
 2. If Peak Result complies with AV limit, AV Result is deemed to comply with AV limit.
 3. Test setup: RBW: 1 MHz, VBW: 3 MHz, Sweep time: auto.

TR-4-E-009 Radiated Emission Test Result

Test Site : DDT 3m Chamber	E:\2014 Report Data\hongjirui\RF.EM6
Test Date : 2014-08-31	Tested By : Leo
EUT : Turning	Model Number : RRAP-01
Power Supply : AC 120V/60Hz	Test Mode : Tx mode 11b CH6
Condition : Temp:24.5'C,Humi:55%, Press:100.1kPa	Antenna/Distance : 2013 HF907/3m/HORIZONTAL
Memo :	

Data: 45

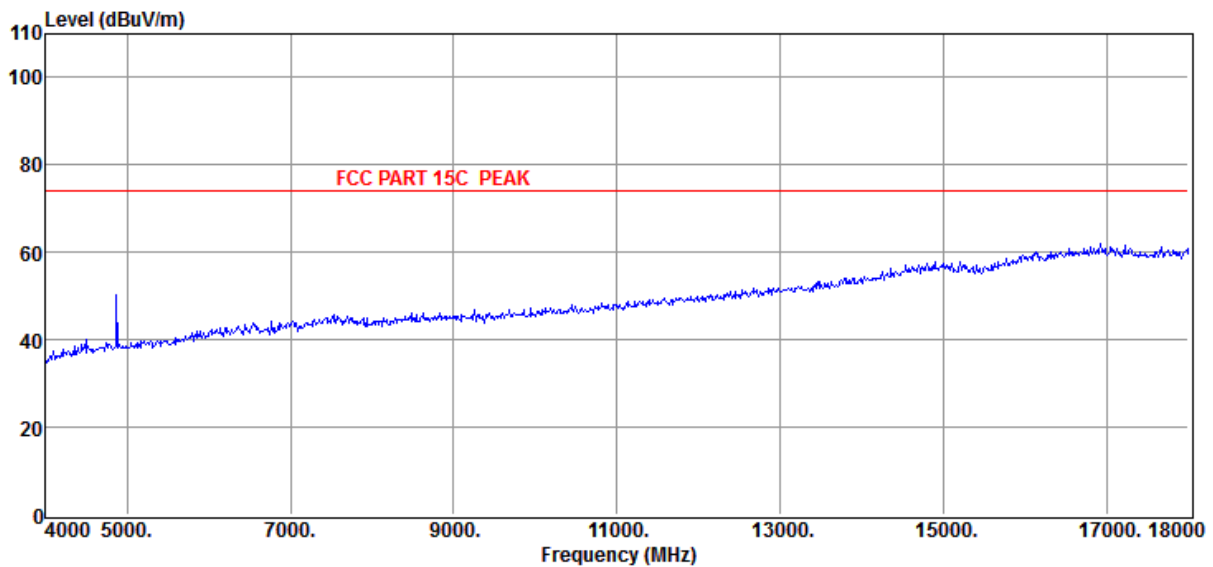

Item	Freq	Read Level	Antenna Factor	PRM Factor	Cable Loss	Result Level	Limit Line	Over Limit	Detector	Polarization
(Mark)	(MHz)	(dBμV)	(dB/m)	dB	dB	(dBμV/m)	(dBμV/m)	(dB)		

- Note: 1. Result Level = Read Level + Antenna Factor + Cable loss - PRM Factor.
 2. If Peak Result complies with AV limit, AV Result is deemed to comply with AV limit.
 3. Test setup: RBW: 1 MHz, VBW: 3 MHz, Sweep time: auto.

TR-4-E-009 Radiated Emission Test Result

Test Site	: DDT 3m Chamber	E:\2014 Report Data\hongjirui\RF.EM6
Test Date	: 2014-08-31	Tested By : Leo
EUT	: Turning	Model Number : RRAP-01
Power Supply	: AC 120V/60Hz	Test Mode : Tx mode 11b CH6
Condition	: Temp:24.5'C,Humi:55%, Press:100.1kPa	Antenna/Distance : 2013 HF907/3m/HORIZONTAL
Memo	:	

Data: 46

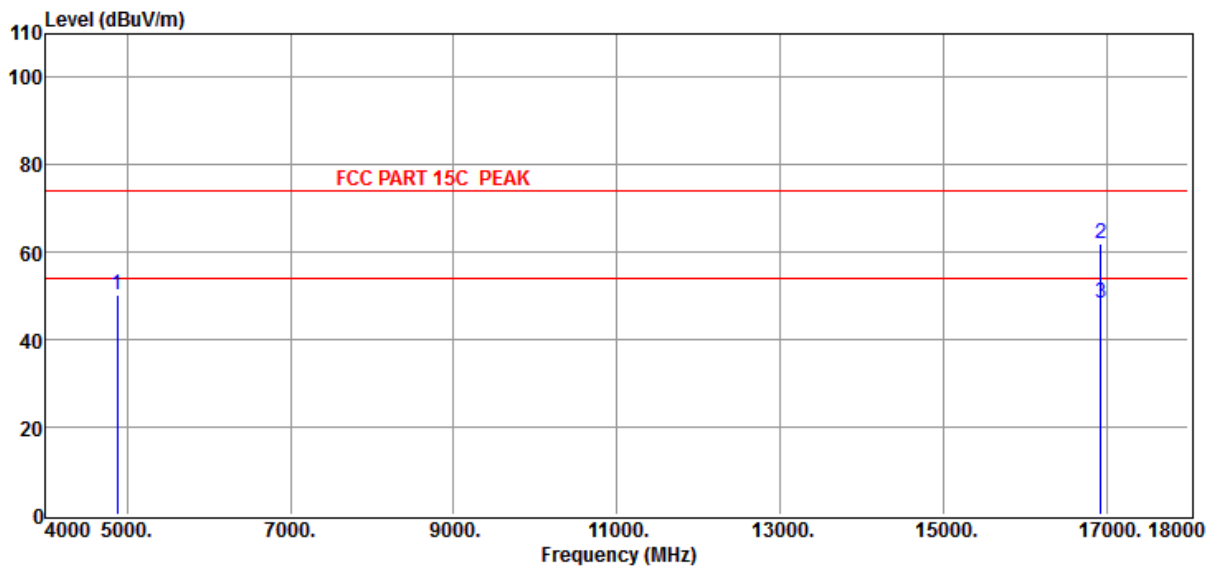

Item (Mark)	Freq (MHz)	Read Level (dBμV)	Antenna Factor (dB/m)	PRM Factor dB	Cable Loss dB	Result Level (dBμV/m)	Limit Line (dBμV/m)	Over Limit (dB)	Detector	Polarization
1	4874.00	46.78	35.51	44.04	12.04	50.29	74.00	-23.71	Peak	HORIZONTAL
2	16922.00	34.02	43.61	41.28	25.60	61.95	74.00	-12.05	Peak	HORIZONTAL
3	16922.00	20.35	43.61	41.28	25.60	48.28	54.00	-5.72	Average	HORIZONTAL

- Note: 1. Result Level = Read Level + Antenna Factor + Cable loss - PRM Factor.
 2. If Peak Result complies with AV limit, AV Result is deemed to comply with AV limit.
 3. Test setup: RBW: 1 MHz, VBW: 3 MHz, Sweep time: auto.

TR-4-E-009 Radiated Emission Test Result

Test Site	: DDT 3m Chamber	E:\2014 Report Data\hongjirui\RF.EM6
Test Date	: 2014-08-31	Tested By : Leo
EUT	: Turning	Model Number : RRAP-01
Power Supply	: AC 120V/60Hz	Test Mode : Tx mode 11b CH6
Condition	: Temp:24.5'C,Humi:55%, Press:100.1kPa	Antenna/Distance : 2013 HF907/3m/VERTICAL
Memo	:	

Data: 47

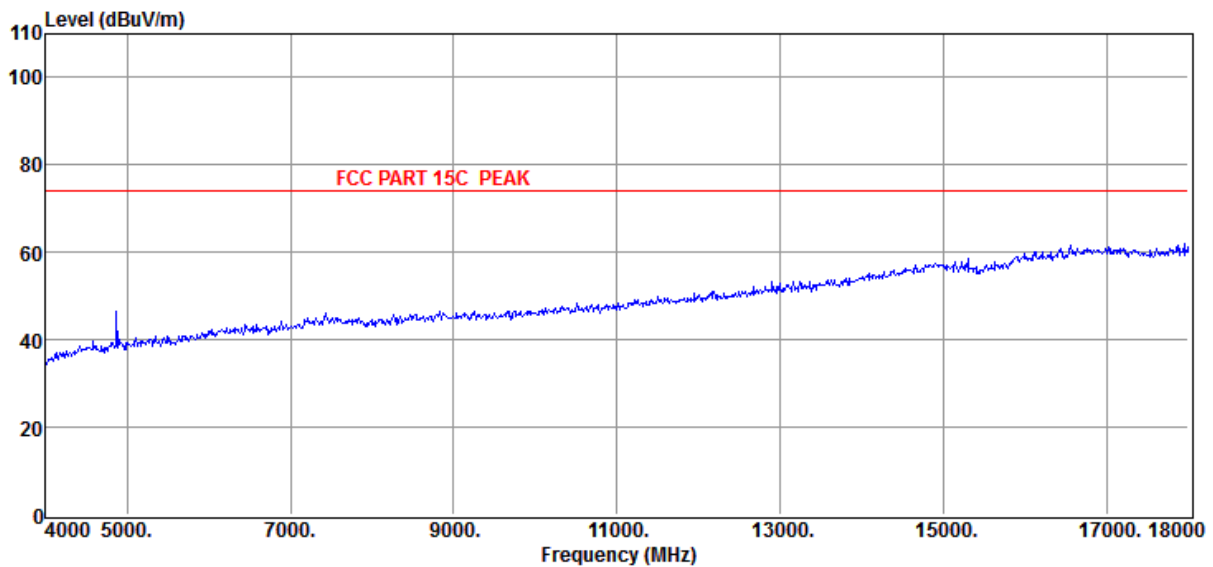

Item	Freq	Read Level	Antenna Factor	PRM Factor	Cable Loss	Result Level	Limit Line	Over Limit	Detector	Polarization
(Mark)	(MHz)	(dBμV)	(dB/m)	dB	dB	(dBμV/m)	(dBμV/m)	(dB)		

- Note: 1. Result Level = Read Level + Antenna Factor + Cable loss - PRM Factor.
 2. If Peak Result complies with AV limit, AV Result is deemed to comply with AV limit.
 3. Test setup: RBW: 1 MHz, VBW: 3 MHz, Sweep time: auto.

TR-4-E-009 Radiated Emission Test Result

Test Site : DDT 3m Chamber	E:\2014 Report Data\hongjirui\RF.EM6
Test Date : 2014-08-31	Tested By : Leo
EUT : Turning	Model Number : RRAP-01
Power Supply : AC 120V/60Hz	Test Mode : Tx mode 11b CH6
Condition : Temp:24.5'C,Humi:55%, Press:100.1kPa	Antenna/Distance : 2013 HF907/3m/VERTICAL
Memo :	

Data: 48

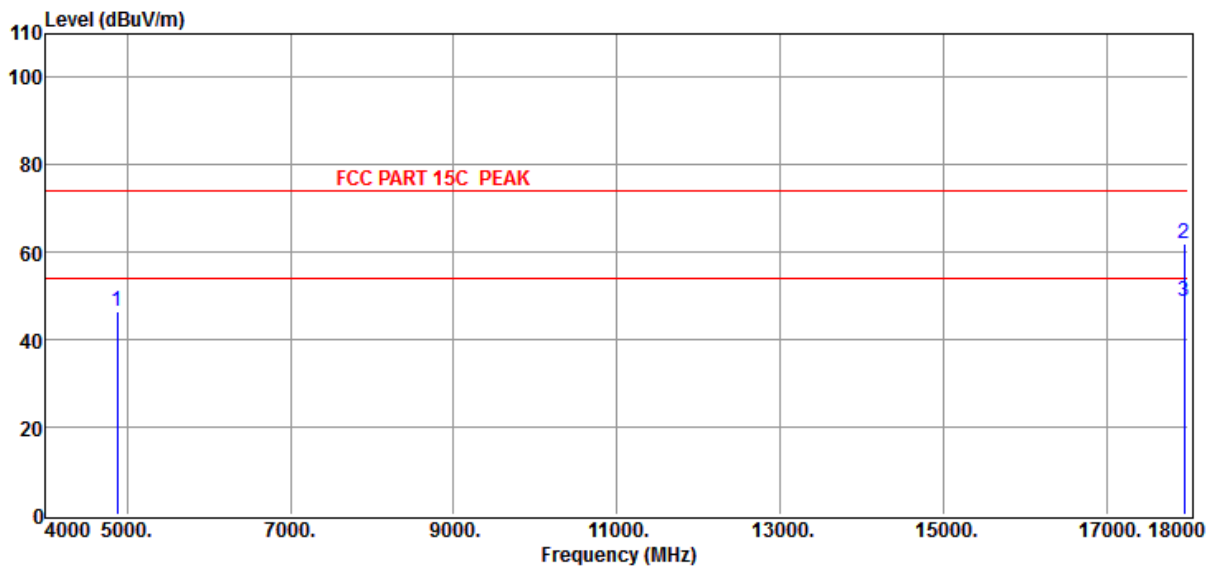

Item (Mark)	Freq (MHz)	Read Level (dBμV)	Antenna Factor (dB/m)	PRM Factor dB	Cable Loss dB	Result Level (dBμV/m)	Limit Line (dBμV/m)	Over Limit (dB)	Detector	Polarization
1	4874.00	43.10	35.51	44.04	12.04	46.61	74.00	-27.39	Peak	VERTICAL
2	17944.00	34.47	43.61	41.72	25.70	62.06	74.00	-11.94	Peak	VERTICAL
3	17944.00	21.03	43.61	41.72	25.70	48.62	54.00	-5.38	Average	VERTICAL

- Note: 1. Result Level = Read Level + Antenna Factor + Cable loss - PRM Factor.
 2. If Peak Result complies with AV limit, AV Result is deemed to comply with AV limit.
 3. Test setup: RBW: 1 MHz, VBW: 3 MHz, Sweep time: auto.

TR-4-E-009 Radiated Emission Test Result

Test Site	: DDT 3m Chamber	E:\2014 Report Data\hongjirui\RF.EM6
Test Date	: 2014-08-31	Tested By : Leo
EUT	: Turning	Model Number : RRAP-01
Power Supply	: AC 120V/60Hz	Test Mode : Tx mode 11b CH11
Condition	: Temp:24.5'C,Humi:55%, Press:100.1kPa	Antenna/Distance : 2013 HF907/3m/VERTICAL
Memo	:	

Data: 49

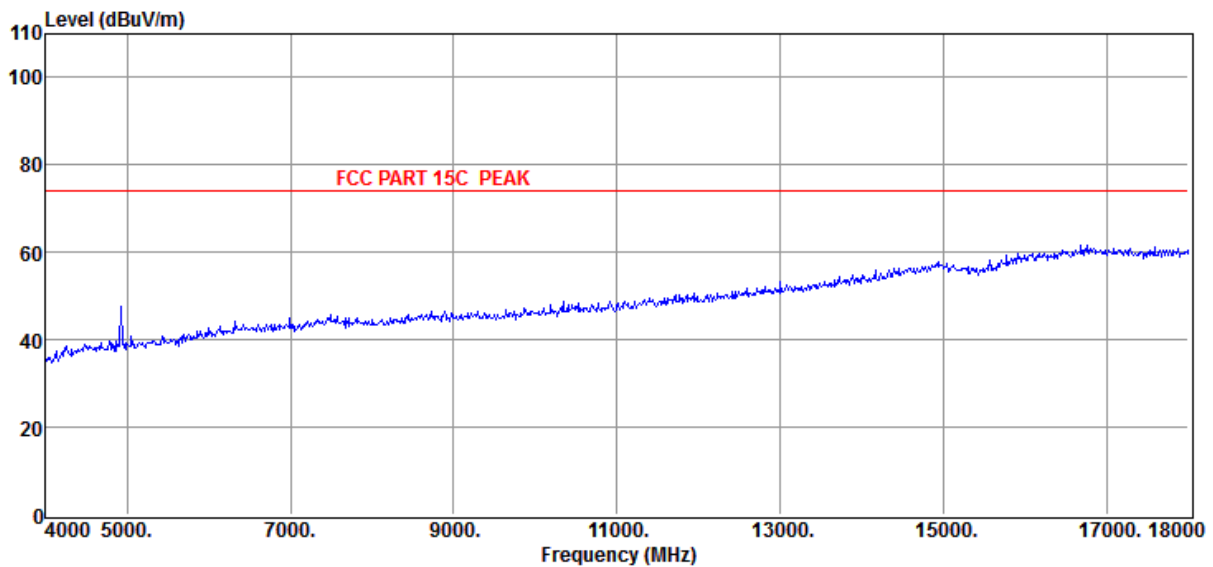

Item	Freq	Read Level	Antenna Factor	PRM Factor	Cable Loss	Result Level	Limit Line	Over Limit	Detector	Polarization
(Mark)	(MHz)	(dBμV)	(dB/m)	dB	dB	(dBμV/m)	(dBμV/m)	(dB)		

- Note: 1. Result Level = Read Level + Antenna Factor + Cable loss - PRM Factor.
 2. If Peak Result complies with AV limit, AV Result is deemed to comply with AV limit.
 3. Test setup: RBW: 1 MHz, VBW: 3 MHz, Sweep time: auto.

TR-4-E-009 Radiated Emission Test Result

Test Site : DDT 3m Chamber	E:\2014 Report Data\hongjirui\RF.EM6
Test Date : 2014-08-31	Tested By : Leo
EUT : Turning	Model Number : RRAP-01
Power Supply : AC 120V/60Hz	Test Mode : Tx mode 11b CH11
Condition : Temp:24.5'C,Humi:55%, Press:100.1kPa	Antenna/Distance : 2013 HF907/3m/VERTICAL
Memo :	

Data: 50

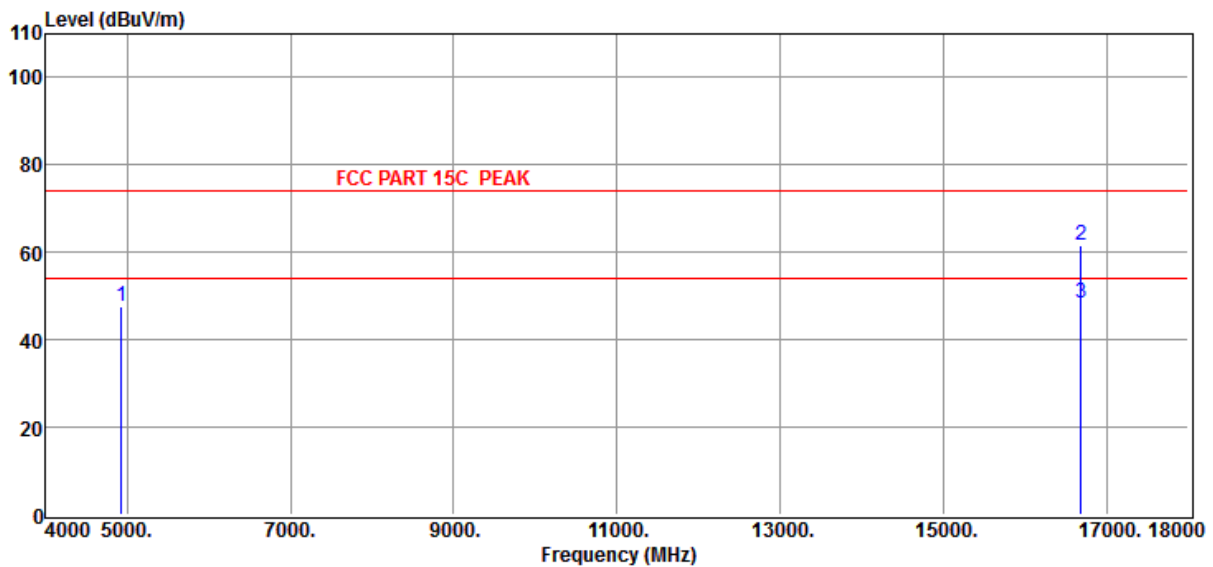

Item (Mark)	Freq (MHz)	Read Level (dBμV)	Antenna Factor (dB/m)	PRM Factor dB	Cable Loss dB	Result Level (dBμV/m)	Limit Line (dBμV/m)	Over Limit (dB)	Detector	Polarization
1	4924.00	44.16	35.59	44.02	12.02	47.75	74.00	-26.25	Peak	VERTICAL
2	16684.00	34.36	43.66	41.22	25.00	61.80	74.00	-12.20	Peak	VERTICAL
3	16684.00	21.03	43.66	41.22	25.00	48.47	54.00	-5.53	Average	VERTICAL

- Note: 1. Result Level = Read Level + Antenna Factor + Cable loss - PRM Factor.
 2. If Peak Result complies with AV limit, AV Result is deemed to comply with AV limit.
 3. Test setup: RBW: 1 MHz, VBW: 3 MHz, Sweep time: auto.

TR-4-E-009 Radiated Emission Test Result

Test Site	: DDT 3m Chamber	E:\2014 Report Data\hongjirui\RF.EM6
Test Date	: 2014-08-31	Tested By : Leo
EUT	: Turning	Model Number : RRAP-01
Power Supply	: AC 120V/60Hz	Test Mode : Tx mode 11b CH11
Condition	: Temp:24.5'C,Humi:55%, Press:100.1kPa	Antenna/Distance : 2013 HF907/3m/HORIZONTAL
Memo	:	

Data: 51

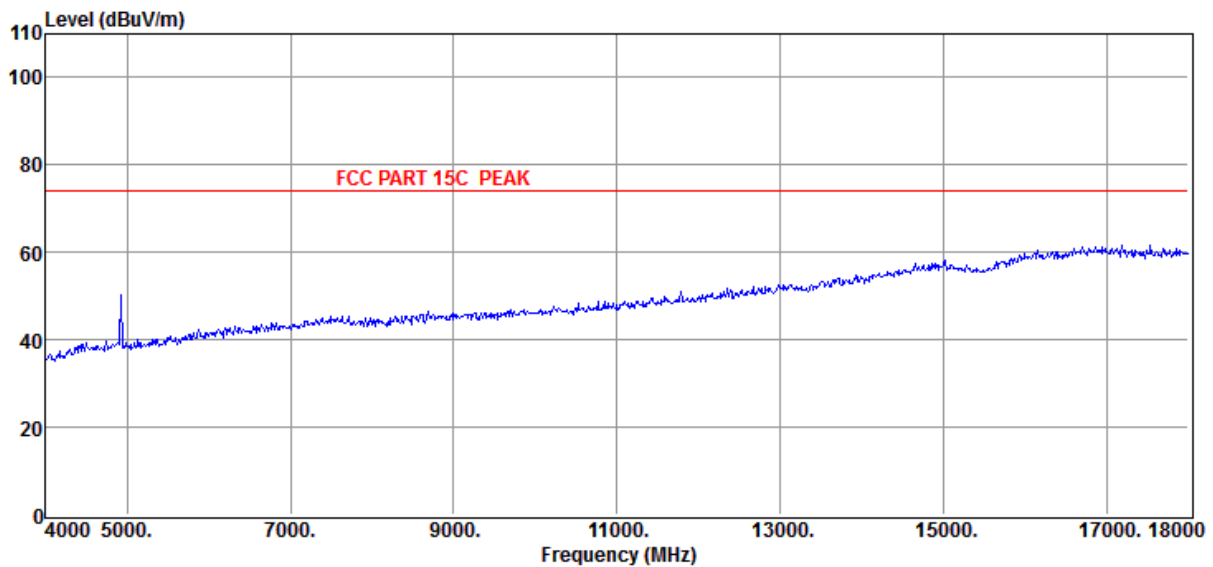

Item	Freq	Read Level	Antenna Factor	PRM Factor	Cable Loss	Result Level	Limit Line	Over Limit	Detector	Polarization
(Mark)	(MHz)	(dBμV)	(dB/m)	dB	dB	(dBμV/m)	(dBμV/m)	(dB)		

- Note: 1. Result Level = Read Level + Antenna Factor + Cable loss - PRM Factor.
 2. If Peak Result complies with AV limit, AV Result is deemed to comply with AV limit.
 3. Test setup: RBW: 1 MHz, VBW: 3 MHz, Sweep time: auto.

TR-4-E-009 Radiated Emission Test Result

Test Site : DDT 3m Chamber	E:\2014 Report Data\hongjirui\RF.EM6
Test Date : 2014-08-31	Tested By : Leo
EUT : Turning	Model Number : RRAP-01
Power Supply : AC 120V/60Hz	Test Mode : Tx mode 11b CH11
Condition : Temp:24.5'C,Humi:55%, Press:100.1kPa	Antenna/Distance : 2013 HF907/3m/HORIZONTAL
Memo :	

Data: 52

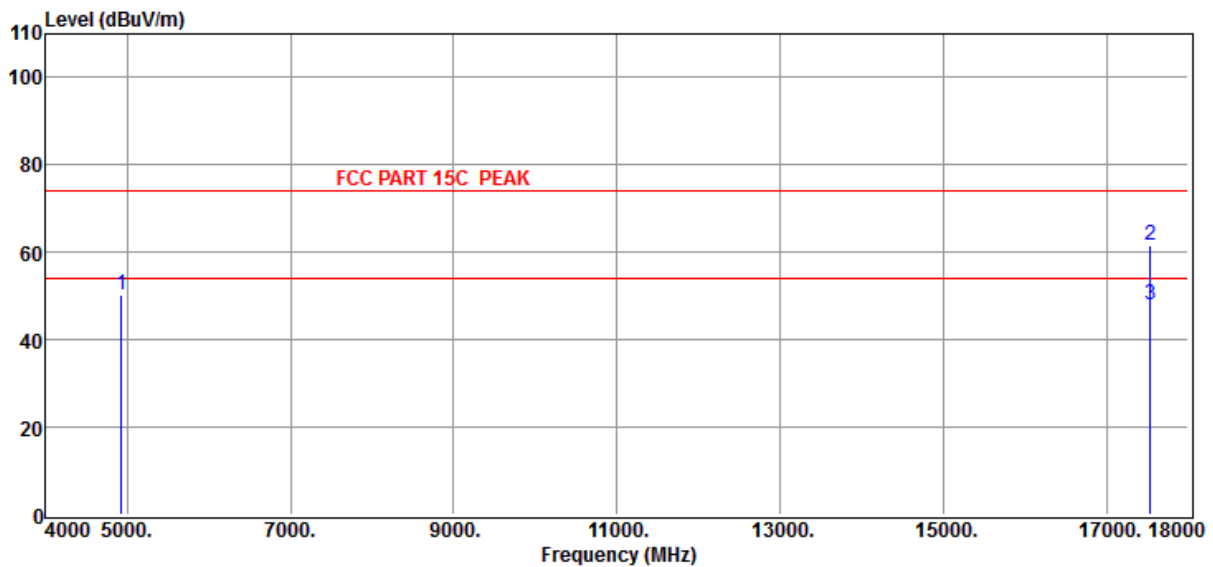

Item (Mark)	Freq (MHz)	Read Level (dBμV)	Antenna Factor (dB/m)	PRM Factor dB	Cable Loss dB	Result Level (dBμV/m)	Limit Line (dBμV/m)	Over Limit (dB)	Detector	Polarization
1	4924.00	46.78	35.59	44.02	12.02	50.37	74.00	-23.63	Peak	HORIZONTAL
2	17538.00	34.40	42.86	40.86	25.20	61.60	74.00	-12.40	Peak	HORIZONTAL
3	17538.00	20.65	42.86	40.86	25.20	47.85	54.00	-6.15	Average	HORIZONTAL

- Note: 1. Result Level = Read Level + Antenna Factor + Cable loss - PRM Factor.
 2. If Peak Result complies with AV limit, AV Result is deemed to comply with AV limit.
 3. Test setup: RBW: 1 MHz, VBW: 3 MHz, Sweep time: auto.

TR-4-E-009 Radiated Emission Test Result

Test Site	: DDT 3m Chamber	E:\2014 Report Data\hongjirui\RF.EM6
Test Date	: 2014-08-31	Tested By : Leo
EUT	: Turning	Model Number : RRAP-01
Power Supply	: AC 120V/60Hz	Test Mode : Tx mode 11g CH1
Condition	: Temp:24.5'C,Humi:55%, Press:100.1kPa	Antenna/Distance : 2013 HF907/3m/HORIZONTAL
Memo	:	

Data: 53

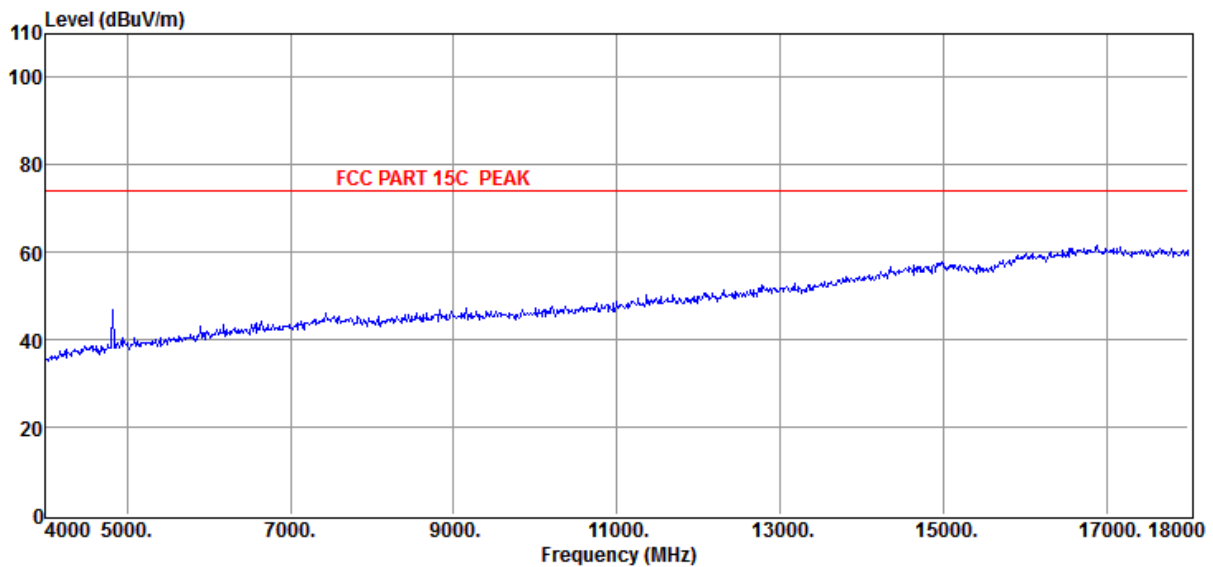

Item	Freq	Read Level	Antenna Factor	PRM Factor	Cable Loss	Result Level	Limit Line	Over Limit	Detector	Polarization
(Mark)	(MHz)	(dBμV)	(dB/m)	dB	dB	(dBμV/m)	(dBμV/m)	(dB)		

- Note: 1. Result Level = Read Level + Antenna Factor + Cable loss - PRM Factor.
 2. If Peak Result complies with AV limit, AV Result is deemed to comply with AV limit.
 3. Test setup: RBW: 1 MHz, VBW: 3 MHz, Sweep time: auto.

TR-4-E-009 Radiated Emission Test Result

Test Site	: DDT 3m Chamber	E:	E:\2014 Report Data\hongjirui\RF.EM6
Test Date	: 2014-08-31	Tested By	: Leo
EUT	: Turning	Model Number	: RRAP-01
Power Supply	: AC 120V/60Hz	Test Mode	: Tx mode 11g CH1
Condition	: Temp:24.5'C,Humi:55%, Press:100.1kPa	Antenna/Distance	: 2013 HF907/3m/HORIZONTAL
Memo	:		

Data: 54

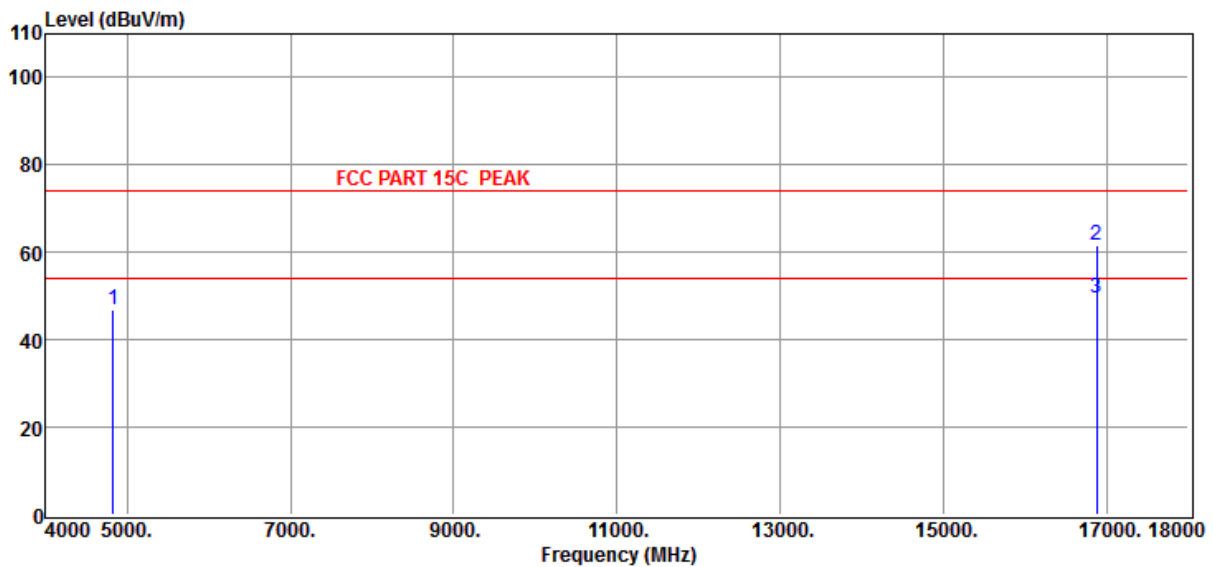

Item (Mark)	Freq (MHz)	Read Level (dBμV)	Antenna Factor (dB/m)	PRM Factor dB	Cable Loss dB	Result Level (dBμV/m)	Limit Line (dBμV/m)	Over Limit (dB)	Detector	Polarization
1	4824.00	43.50	35.42	44.06	12.07	46.93	74.00	-27.07	Peak	HORIZONTAL
2	16880.00	33.75	43.62	41.28	25.60	61.69	74.00	-12.31	Peak	HORIZONTAL
3	16880.00	21.45	43.62	41.28	25.60	49.39	54.00	-4.61	Average	HORIZONTAL

- Note: 1. Result Level = Read Level + Antenna Factor + Cable loss - PRM Factor.
 2. If Peak Result complies with AV limit, AV Result is deemed to comply with AV limit.
 3. Test setup: RBW: 1 MHz, VBW: 3 MHz, Sweep time: auto.

TR-4-E-009 Radiated Emission Test Result

Test Site : DDT 3m Chamber	E:\2014 Report Data\hongjirui\RF.EM6
Test Date : 2014-08-31	Tested By : Leo
EUT : Turning	Model Number : RRAP-01
Power Supply : AC 120V/60Hz	Test Mode : Tx mode 11g CH1
Condition : Temp:24.5'C,Humi:55%, Press:100.1kPa	Antenna/Distance : 2013 HF907/3m/VERTICAL
Memo :	

Data: 55

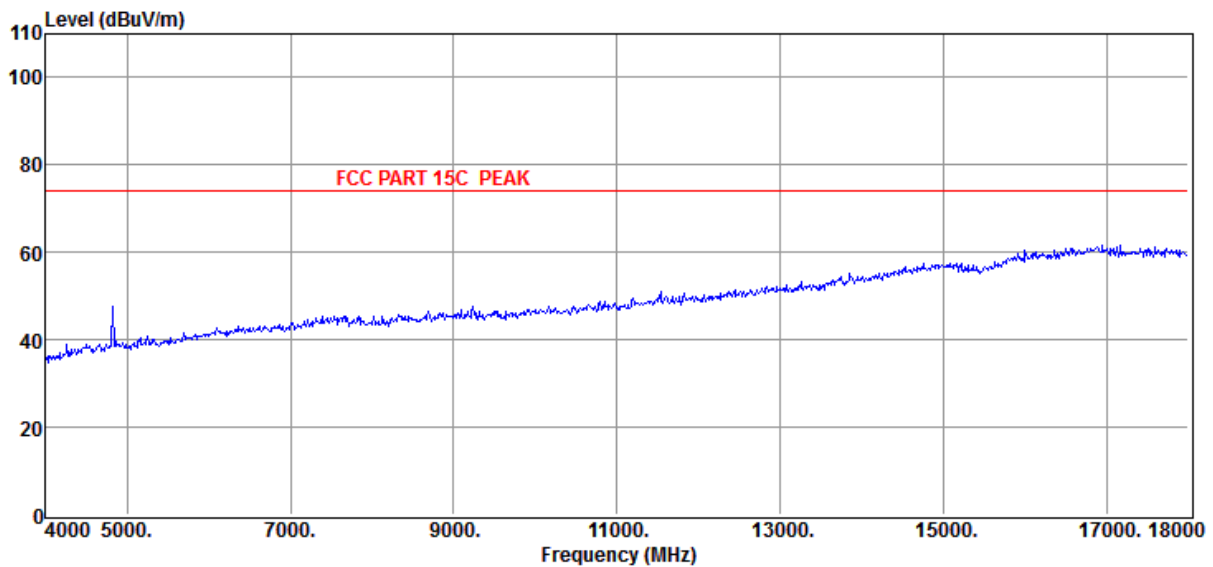

Item	Freq	Read Level	Antenna Factor	PRM Factor	Cable Loss	Result Level	Limit Line	Over Limit	Detector	Polarization
(Mark)	(MHz)	(dBμV)	(dB/m)	dB	dB	(dBμV/m)	(dBμV/m)	(dB)		

- Note: 1. Result Level = Read Level + Antenna Factor + Cable loss - PRM Factor.
 2. If Peak Result complies with AV limit, AV Result is deemed to comply with AV limit.
 3. Test setup: RBW: 1 MHz, VBW: 3 MHz, Sweep time: auto.

TR-4-E-009 Radiated Emission Test Result

Test Site	: DDT 3m Chamber	E:\2014 Report Data\hongjirui\RF.EM6
Test Date	: 2014-08-31	Tested By : Leo
EUT	: Turning	Model Number : RRAP-01
Power Supply	: AC 120V/60Hz	Test Mode : Tx mode 11g CH1
Condition	: Temp:24.5'C,Humi:55%, Press:100.1kPa	Antenna/Distance : 2013 HF907/3m/VERTICAL
Memo	:	

Data: 56

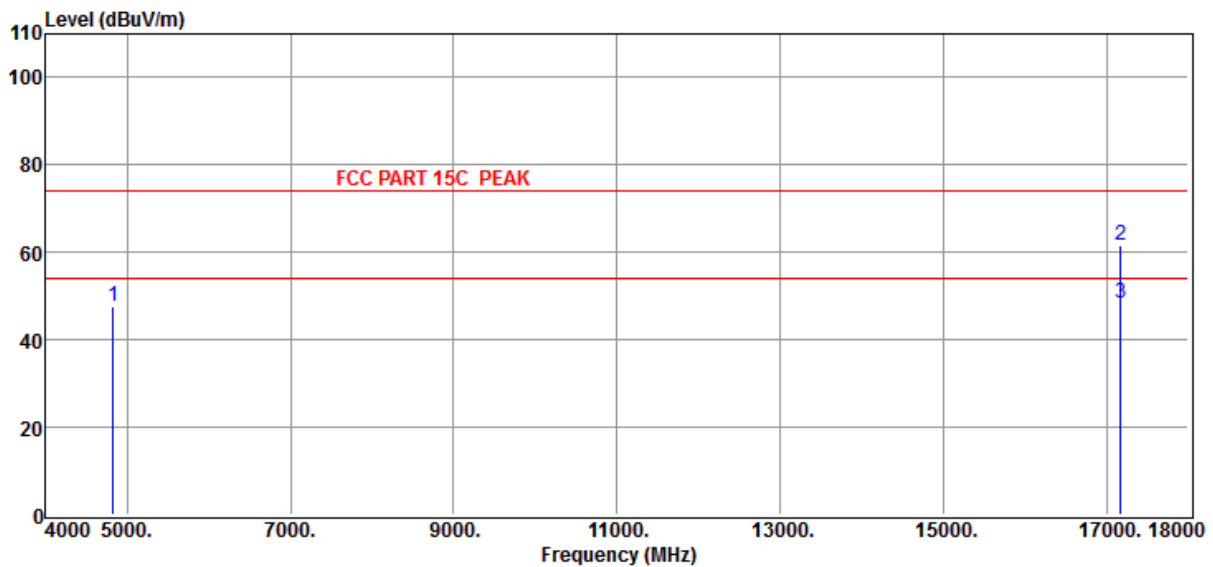

Item (Mark)	Freq (MHz)	Read Level (dBμV)	Antenna Factor (dB/m)	PRM Factor dB	Cable Loss dB	Result Level (dBμV/m)	Limit Line (dBμV/m)	Over Limit (dB)	Detector	Polarization
1	4824.00	44.02	35.42	44.06	12.07	47.45	74.00	-26.55	Peak	VERTICAL
2	17174.00	34.05	43.33	41.15	25.47	61.70	74.00	-12.30	Peak	VERTICAL
3	17174.00	20.58	43.33	41.15	25.47	48.23	54.00	-5.77	Average	VERTICAL

- Note: 1. Result Level = Read Level + Antenna Factor + Cable loss - PRM Factor.
 2. If Peak Result complies with AV limit, AV Result is deemed to comply with AV limit.
 3. Test setup: RBW: 1 MHz, VBW: 3 MHz, Sweep time: auto.

TR-4-E-009 Radiated Emission Test Result

Test Site	: DDT 3m Chamber	E:\2014 Report Data\hongjirui\RF.EM6
Test Date	: 2014-08-31	Tested By : Leo
EUT	: Turning	Model Number : RRAP-01
Power Supply	: AC 120V/60Hz	Test Mode : Tx mode 11g CH6
Condition	: Temp:24.5'C,Humi:55%, Press:100.1kPa	Antenna/Distance : 2013 HF907/3m/VERTICAL
Memo	:	

Data: 57

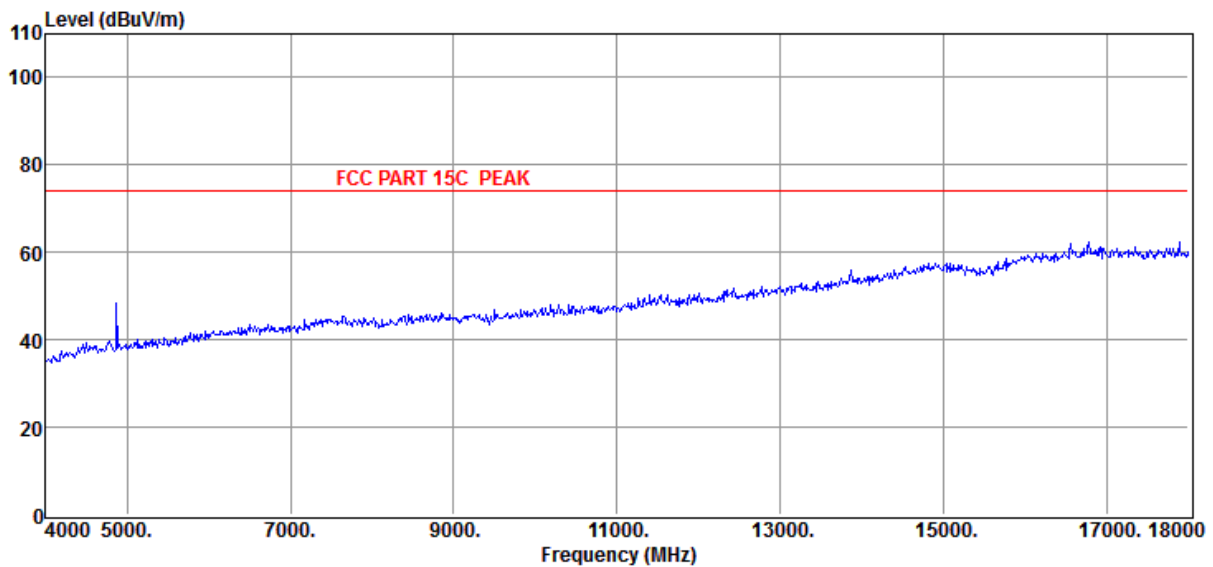

Item	Freq	Read Level	Antenna Factor	PRM Factor	Cable Loss	Result Level	Limit Line	Over Limit	Detector	Polarization
(Mark)	(MHz)	(dBμV)	(dB/m)	dB	dB	(dBμV/m)	(dBμV/m)	(dB)		

- Note: 1. Result Level = Read Level + Antenna Factor + Cable loss - PRM Factor.
 2. If Peak Result complies with AV limit, AV Result is deemed to comply with AV limit.
 3. Test setup: RBW: 1 MHz, VBW: 3 MHz, Sweep time: auto.

TR-4-E-009 Radiated Emission Test Result

Test Site : DDT 3m Chamber	E:\2014 Report Data\hongjirui\RF.EM6
Test Date : 2014-08-31	Tested By : Leo
EUT : Turning	Model Number : RRAP-01
Power Supply : AC 120V/60Hz	Test Mode : Tx mode 11g CH6
Condition : Temp:24.5'C,Humi:55%, Press:100.1kPa	Antenna/Distance : 2013 HF907/3m/VERTICAL
Memo :	

Data: 58

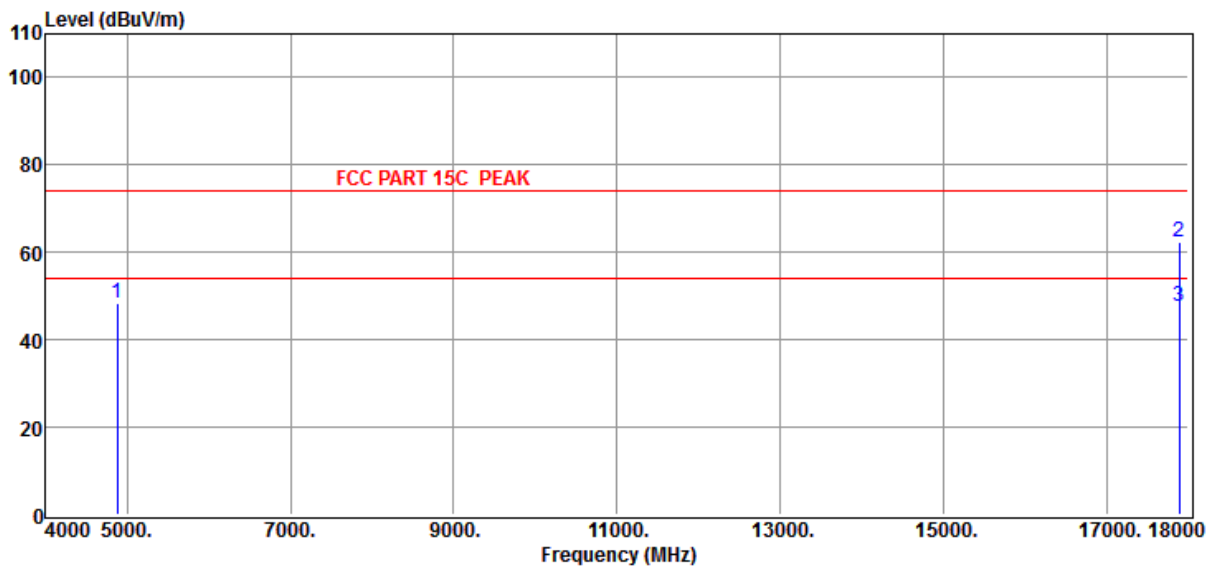

Item (Mark)	Freq (MHz)	Read Level (dBμV)	Antenna Factor (dB/m)	PRM Factor dB	Cable Loss dB	Result Level (dBμV/m)	Limit Line (dBμV/m)	Over Limit (dB)	Detector	Polarization
1	4874.00	44.91	35.51	44.04	12.04	48.42	74.00	-25.58	Peak	VERTICAL
2	17888.00	35.13	43.48	41.63	25.45	62.43	74.00	-11.57	Peak	VERTICAL
3	17888.00	20.31	43.48	41.63	25.45	47.61	54.00	-6.39	Average	VERTICAL

- Note: 1. Result Level = Read Level + Antenna Factor + Cable loss - PRM Factor.
 2. If Peak Result complies with AV limit, AV Result is deemed to comply with AV limit.
 3. Test setup: RBW: 1 MHz, VBW: 3 MHz, Sweep time: auto.

TR-4-E-009 Radiated Emission Test Result

Test Site	: DDT 3m Chamber	E:\2014 Report Data\hongjirui\RF.EM6
Test Date	: 2014-08-31	Tested By : Leo
EUT	: Turning	Model Number : RRAP-01
Power Supply	: AC 120V/60Hz	Test Mode : Tx mode 11g CH6
Condition	: Temp:24.5'C,Humi:55%, Press:100.1kPa	Antenna/Distance : 2013 HF907/3m/HORIZONTAL
Memo	:	

Data: 59

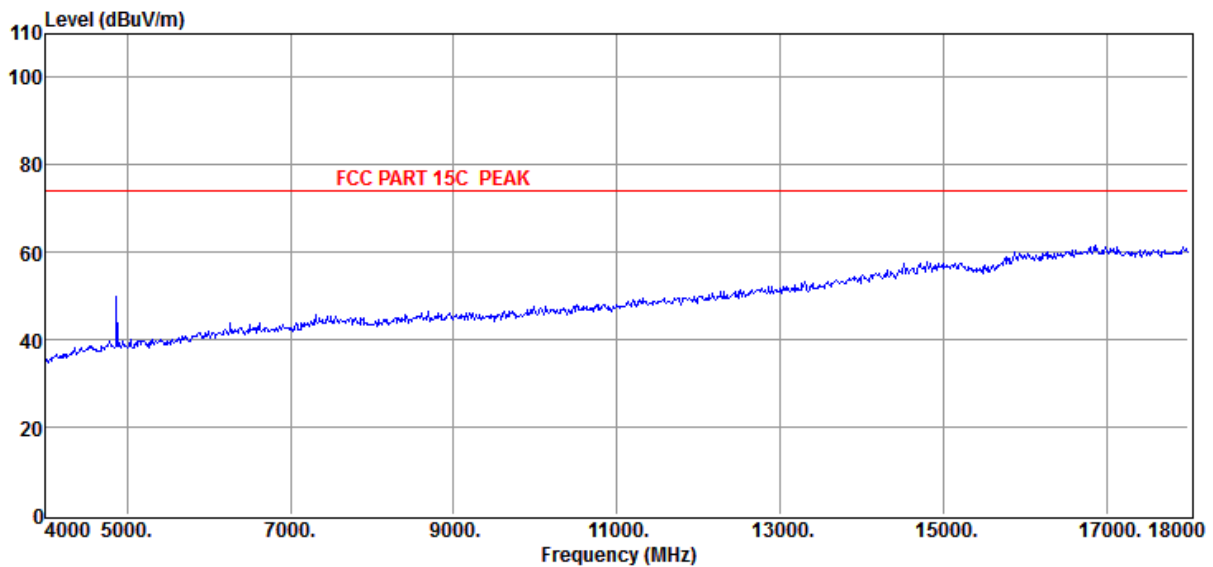

Item	Freq	Read Level	Antenna Factor	PRM Factor	Cable Loss	Result Level	Limit Line	Over Limit	Detector	Polarization
(Mark)	(MHz)	(dBμV)	(dB/m)	dB	dB	(dBμV/m)	(dBμV/m)	(dB)		

- Note: 1. Result Level = Read Level + Antenna Factor + Cable loss - PRM Factor.
 2. If Peak Result complies with AV limit, AV Result is deemed to comply with AV limit.
 3. Test setup: RBW: 1 MHz, VBW: 3 MHz, Sweep time: auto.

TR-4-E-009 Radiated Emission Test Result

Test Site	: DDT 3m Chamber	E:\2014 Report Data\hongjirui\RF.EM6
Test Date	: 2014-08-31	Tested By : Leo
EUT	: Turning	Model Number : RRAP-01
Power Supply	: AC 120V/60Hz	Test Mode : Tx mode 11g CH6
Condition	: Temp:24.5'C,Humi:55%, Press:100.1kPa	Antenna/Distance : 2013 HF907/3m/HORIZONTAL
Memo	:	

Data: 60

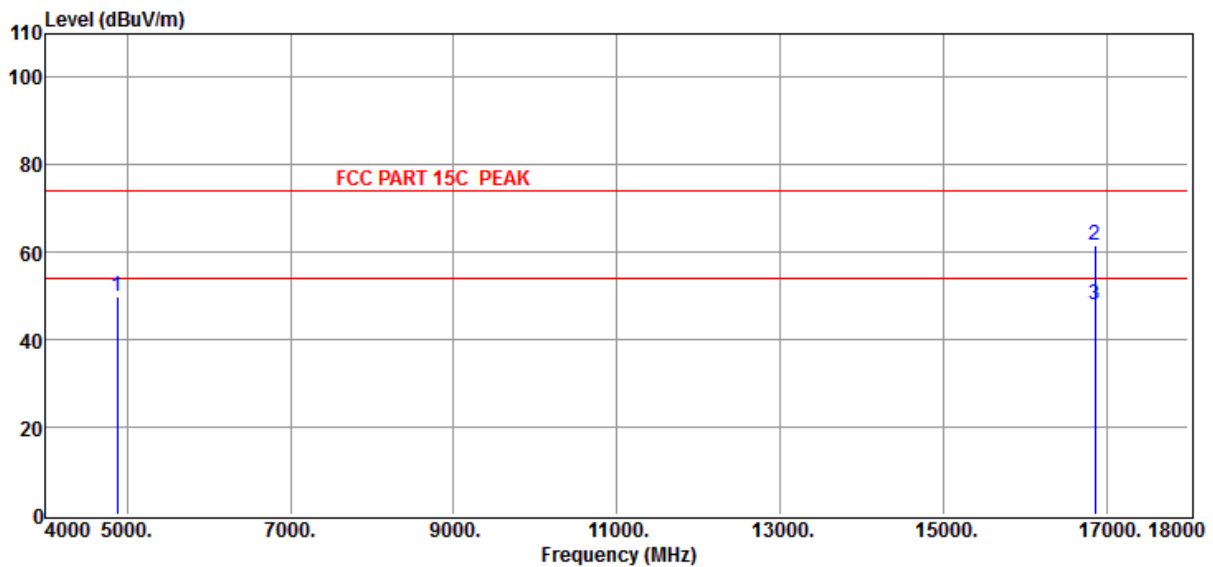

Item (Mark)	Freq (MHz)	Read Level (dBμV)	Antenna Factor (dB/m)	PRM Factor dB	Cable Loss dB	Result Level (dBμV/m)	Limit Line (dBμV/m)	Over Limit (dB)	Detector	Polarization
1	4874.00	46.38	35.51	44.04	12.04	49.89	74.00	-24.11	Peak	HORIZONTAL
2	16852.00	33.56	43.63	41.27	25.60	61.52	74.00	-12.48	Peak	HORIZONTAL
3	16852.00	20.14	43.63	41.27	25.60	48.10	54.00	-5.90	Average	HORIZONTAL

- Note: 1. Result Level = Read Level + Antenna Factor + Cable loss - PRM Factor.
 2. If Peak Result complies with AV limit, AV Result is deemed to comply with AV limit.
 3. Test setup: RBW: 1 MHz, VBW: 3 MHz, Sweep time: auto.

TR-4-E-009 Radiated Emission Test Result

Test Site	: DDT 3m Chamber	E:\2014 Report Data\hongjirui\RF.EM6
Test Date	: 2014-08-31	Tested By : Leo
EUT	: Turning	Model Number : RRAP-01
Power Supply	: AC 120V/60Hz	Test Mode : Tx mode 11g CH11
Condition	: Temp:24.5'C,Humi:55%, Press:100.1kPa	Antenna/Distance : 2013 HF907/3m/HORIZONTAL
Memo	:	

Data: 61

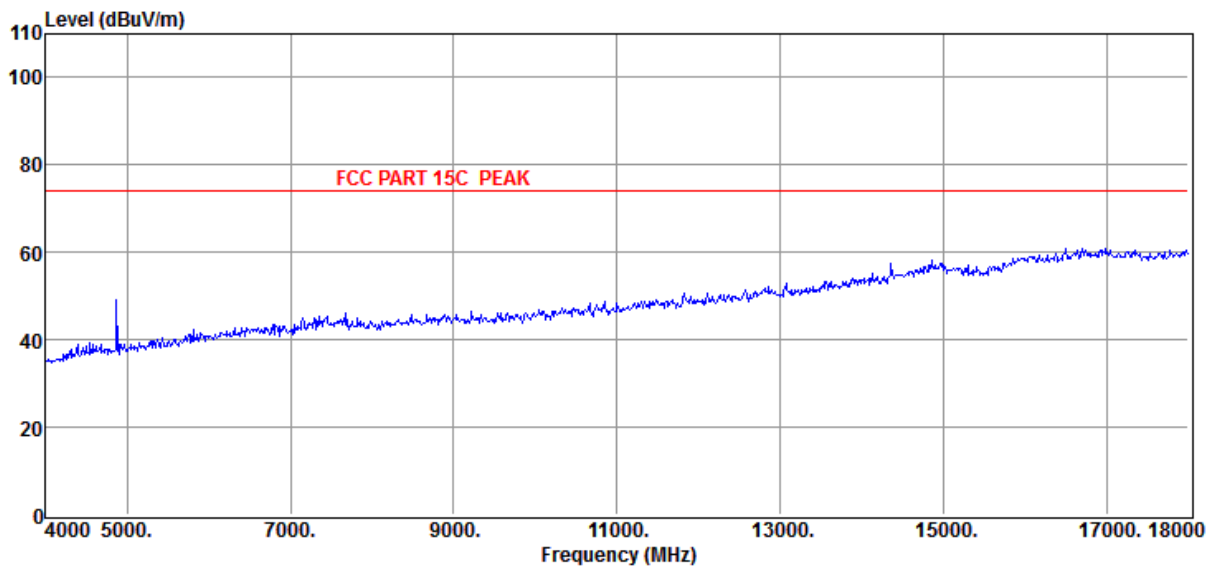

Item	Freq	Read Level	Antenna Factor	PRM Factor	Cable Loss	Result Level	Limit Line	Over Limit	Detector	Polarization
(Mark)	(MHz)	(dBμV)	(dB/m)	dB	dB	(dBμV/m)	(dBμV/m)	(dB)		

- Note: 1. Result Level = Read Level + Antenna Factor + Cable loss - PRM Factor.
 2. If Peak Result complies with AV limit, AV Result is deemed to comply with AV limit.
 3. Test setup: RBW: 1 MHz, VBW: 3 MHz, Sweep time: auto.

TR-4-E-009 Radiated Emission Test Result

Test Site : DDT 3m Chamber	E:\2014 Report Data\hongjirui\RF.EM6
Test Date : 2014-08-31	Tested By : Leo
EUT : Turning	Model Number : RRAP-01
Power Supply : AC 120V/60Hz	Test Mode : Tx mode 11g CH11
Condition : Temp:24.5'C,Humi:55%, Press:100.1kPa	Antenna/Distance : 2013 HF907/3m/HORIZONTAL
Memo :	

Data: 62

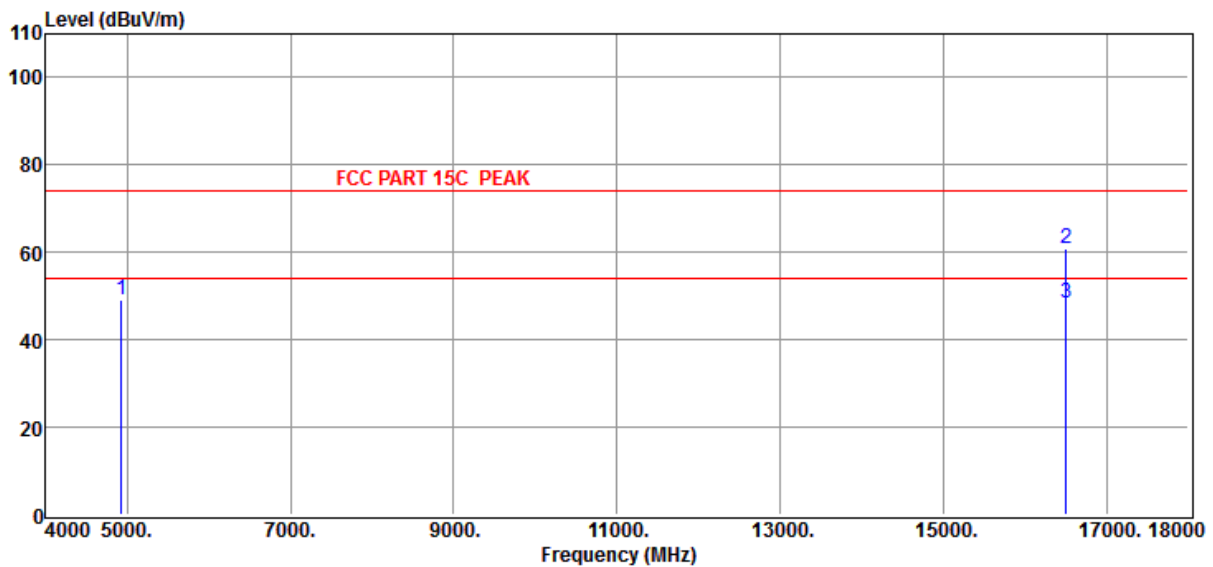

Item (Mark)	Freq (MHz)	Read Level (dBμV)	Antenna Factor (dB/m)	PRM Factor dB	Cable Loss dB	Result Level (dBμV/m)	Limit Line (dBμV/m)	Over Limit (dB)	Detector	Polarization
1	4924.00	45.53	35.59	44.02	12.02	49.12	74.00	-24.88	Peak	HORIZONTAL
2	16502.00	33.93	43.70	41.17	24.40	60.86	74.00	-13.14	Peak	HORIZONTAL
3	16502.00	21.30	43.70	41.17	24.40	48.23	54.00	-5.77	Average	HORIZONTAL

- Note: 1. Result Level = Read Level + Antenna Factor + Cable loss - PRM Factor.
 2. If Peak Result complies with AV limit, AV Result is deemed to comply with AV limit.
 3. Test setup: RBW: 1 MHz, VBW: 3 MHz, Sweep time: auto.

TR-4-E-009 Radiated Emission Test Result

Test Site	: DDT 3m Chamber	E:\2014 Report Data\hongjirui\RF.EM6
Test Date	: 2014-08-31	Tested By : Leo
EUT	: Turning	Model Number : RRAP-01
Power Supply	: AC 120V/60Hz	Test Mode : Tx mode 11g CH11
Condition	: Temp:24.5'C,Humi:55%, Press:100.1kPa	Antenna/Distance : 2013 HF907/3m/VERTICAL
Memo	:	

Data: 63

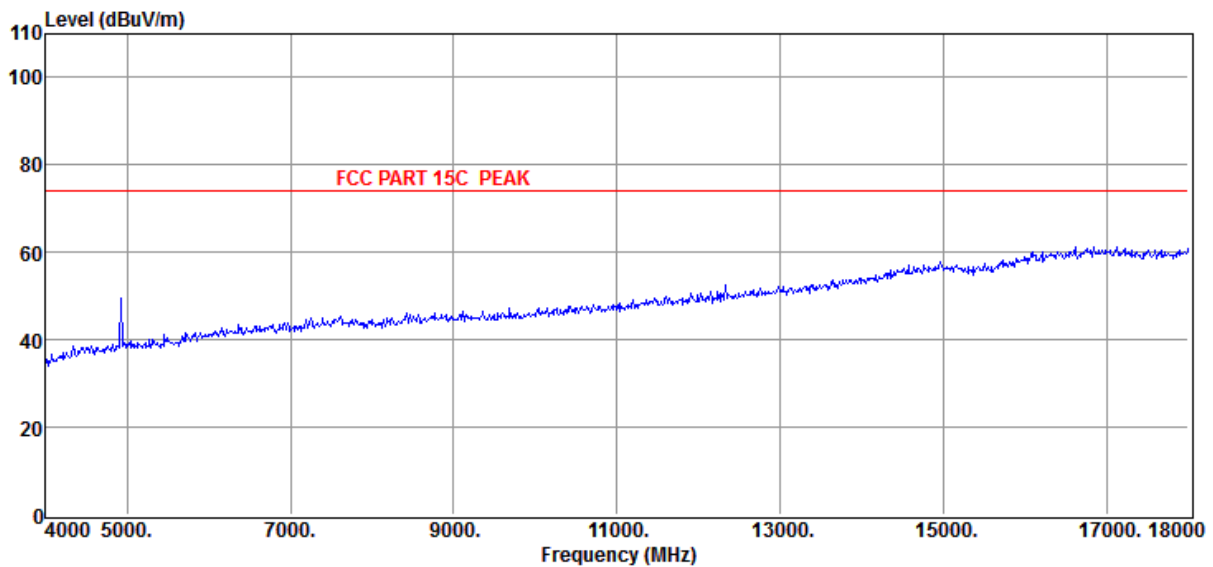

Item	Freq	Read Level	Antenna Factor	PRM Factor	Cable Loss	Result Level	Limit Line	Over Limit	Detector	Polarization
(Mark)	(MHz)	(dBμV)	(dB/m)	dB	dB	(dBμV/m)	(dBμV/m)	(dB)		

- Note: 1. Result Level = Read Level + Antenna Factor + Cable loss - PRM Factor.
 2. If Peak Result complies with AV limit, AV Result is deemed to comply with AV limit.
 3. Test setup: RBW: 1 MHz, VBW: 3 MHz, Sweep time: auto.

TR-4-E-009 Radiated Emission Test Result

Test Site : DDT 3m Chamber	E:\2014 Report Data\hongjirui\RF.EM6
Test Date : 2014-08-31	Tested By : Leo
EUT : Turning	Model Number : RRAP-01
Power Supply : AC 120V/60Hz	Test Mode : Tx mode 11g CH11
Condition : Temp:24.5'C,Humi:55%, Press:100.1kPa	Antenna/Distance : 2013 HF907/3m/VERTICAL
Memo :	

Data: 64

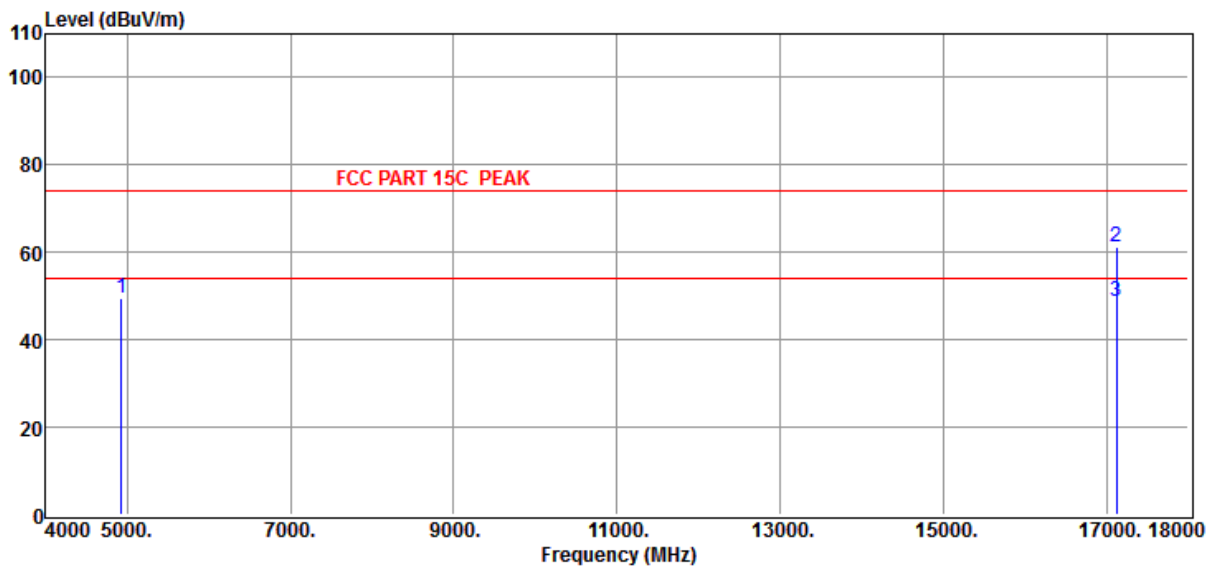

Item (Mark)	Freq (MHz)	Read Level (dBμV)	Antenna Factor (dB/m)	PRM Factor dB	Cable Loss dB	Result Level (dBμV/m)	Limit Line (dBμV/m)	Over Limit (dB)	Detector	Polarization
1	4924.00	46.00	35.59	44.02	12.02	49.59	74.00	-24.41	Peak	VERTICAL
2	17118.00	33.69	43.41	41.19	25.47	61.38	74.00	-12.62	Peak	VERTICAL
3	17118.00	21.05	43.41	41.19	25.47	48.74	54.00	-5.26	Average	VERTICAL

- Note: 1. Result Level = Read Level + Antenna Factor + Cable loss - PRM Factor.
 2. If Peak Result complies with AV limit, AV Result is deemed to comply with AV limit.
 3. Test setup: RBW: 1 MHz, VBW: 3 MHz, Sweep time: auto.

TR-4-E-009 Radiated Emission Test Result

Test Site	: DDT 3m Chamber	E:\2014 Report Data\hongjirui\RF.EM6
Test Date	: 2014-08-31	Tested By : Leo
EUT	: Turning	Model Number : RRAP-01
Power Supply	: AC 120V/60Hz	Test Mode : Tx mode 11n HT20 CH1
Condition	: Temp:24.5'C,Humi:55%, Press:100.1kPa	Antenna/Distance : 2013 HF907/3m/VERTICAL
Memo	:	

Data: 65

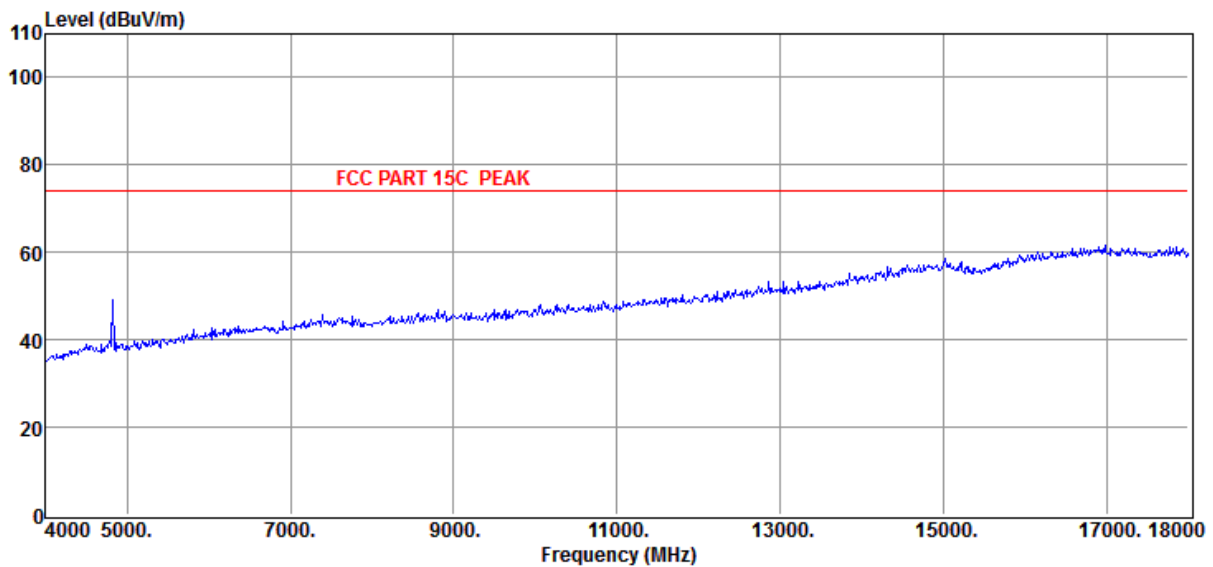

Item	Freq	Read Level	Antenna Factor	PRM Factor	Cable Loss	Result Level	Limit Line	Over Limit	Detector	Polarization
(Mark)	(MHz)	(dBμV)	(dB/m)	dB	dB	(dBμV/m)	(dBμV/m)	(dB)		

- Note: 1. Result Level = Read Level + Antenna Factor + Cable loss - PRM Factor.
 2. If Peak Result complies with AV limit, AV Result is deemed to comply with AV limit.
 3. Test setup: RBW: 1 MHz, VBW: 3 MHz, Sweep time: auto.

TR-4-E-009 Radiated Emission Test Result

Test Site : DDT 3m Chamber	E:\2014 Report Data\hongjirui\RF.EM6
Test Date : 2014-08-31	Tested By : Leo
EUT : Turning	Model Number : RRAP-01
Power Supply : AC 120V/60Hz	Test Mode : Tx mode 11n HT20 CH1
Condition : Temp:24.5'C,Humi:55%, Press:100.1kPa	Antenna/Distance : 2013 HF907/3m/VERTICAL
Memo :	

Data: 66

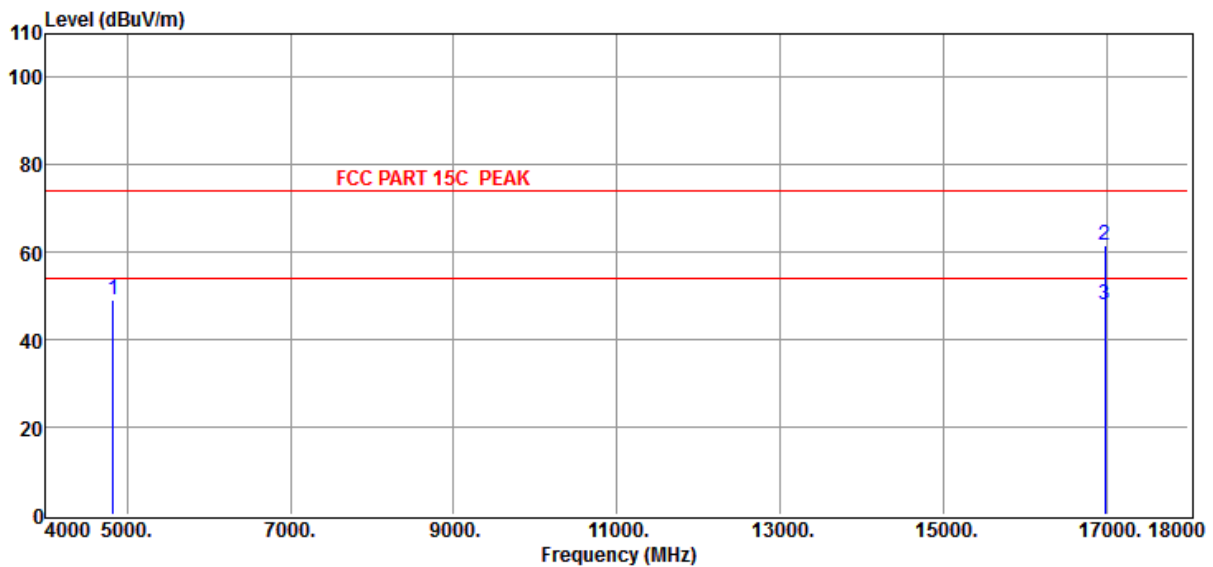

Item (Mark)	Freq (MHz)	Read Level (dBμV)	Antenna Factor (dB/m)	PRM Factor dB	Cable Loss dB	Result Level (dBμV/m)	Limit Line (dBμV/m)	Over Limit (dB)	Detector	Polarization
1	4824.00	45.52	35.42	44.06	12.07	48.95	74.00	-25.05	Peak	VERTICAL
2	16978.00	33.61	43.60	41.29	25.60	61.52	74.00	-12.48	Peak	VERTICAL
3	16978.00	20.14	43.60	41.29	25.60	48.05	54.00	-5.95	Average	VERTICAL

- Note: 1. Result Level = Read Level + Antenna Factor + Cable loss - PRM Factor.
 2. If Peak Result complies with AV limit, AV Result is deemed to comply with AV limit.
 3. Test setup: RBW: 1 MHz, VBW: 3 MHz, Sweep time: auto.

TR-4-E-009 Radiated Emission Test Result

Test Site	: DDT 3m Chamber	E:\2014 Report Data\hongjirui\RF.EM6
Test Date	: 2014-08-31	Tested By : Leo
EUT	: Turning	Model Number : RRAP-01
Power Supply	: AC 120V/60Hz	Test Mode : Tx mode 11n HT20 CH1
Condition	: Temp:24.5'C,Humi:55%, Press:100.1kPa	Antenna/Distance : 2013 HF907/3m/HORIZONTAL
Memo	:	

Data: 67

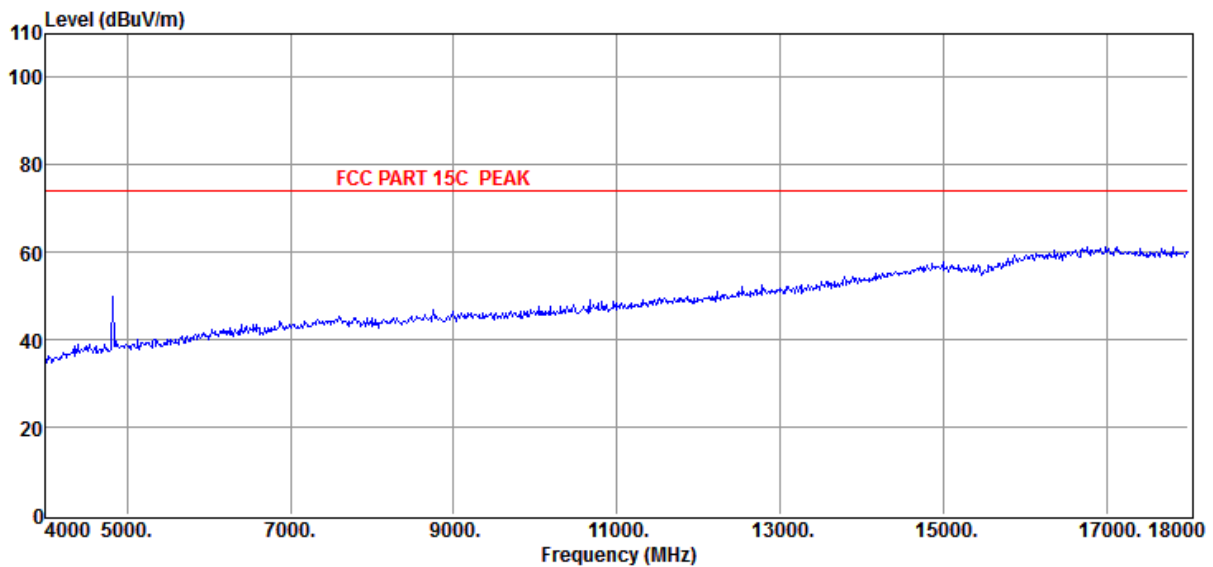

Item	Freq	Read Level	Antenna Factor	PRM Factor	Cable Loss	Result Level	Limit Line	Over Limit	Detector	Polarization
(Mark)	(MHz)	(dBμV)	(dB/m)	dB	dB	(dBμV/m)	(dBμV/m)	(dB)		

- Note: 1. Result Level = Read Level + Antenna Factor + Cable loss - PRM Factor.
 2. If Peak Result complies with AV limit, AV Result is deemed to comply with AV limit.
 3. Test setup: RBW: 1 MHz, VBW: 3 MHz, Sweep time: auto.

TR-4-E-009 Radiated Emission Test Result

Test Site	: DDT 3m Chamber	E:	:\2014 Report Data\hongjirui\RF.EM6
Test Date	: 2014-08-31	Tested By	: Leo
EUT	: Turning	Model Number	: RRAP-01
Power Supply	: AC 120V/60Hz	Test Mode	: Tx mode 11n HT20 CH1
Condition	: Temp:24.5'C,Humi:55%, Press:100.1kPa	Antenna/Distance	: 2013 HF907/3m/HORIZONTAL
Memo	:		

Data: 68

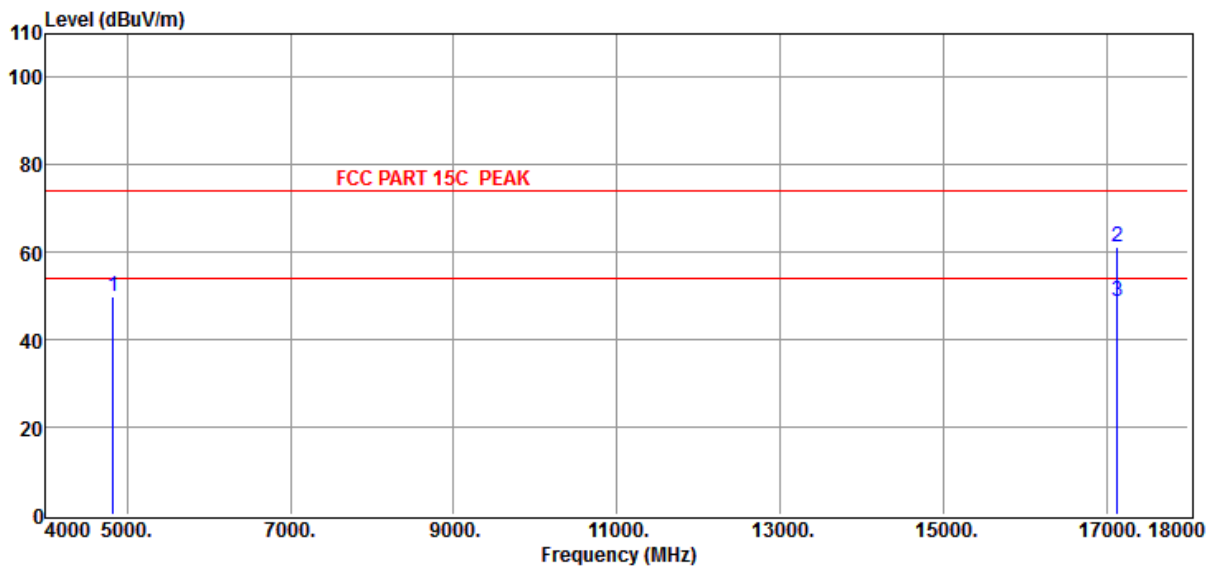

Item (Mark)	Freq (MHz)	Read Level (dBμV)	Antenna Factor (dB/m)	PRM Factor dB	Cable Loss dB	Result Level (dBμV/m)	Limit Line (dBμV/m)	Over Limit (dB)	Detector	Polarization
1	4824.00	46.47	35.42	44.06	12.07	49.90	74.00	-24.10	Peak	HORIZONTAL
2	17132.00	33.43	43.39	41.19	25.47	61.10	74.00	-12.90	Peak	HORIZONTAL
3	17132.00	21.04	43.39	41.19	25.47	48.71	54.00	-5.29	Average	HORIZONTAL

- Note: 1. Result Level = Read Level + Antenna Factor + Cable loss - PRM Factor.
 2. If Peak Result complies with AV limit, AV Result is deemed to comply with AV limit.
 3. Test setup: RBW: 1 MHz, VBW: 3 MHz, Sweep time: auto.

TR-4-E-009 Radiated Emission Test Result

Test Site	: DDT 3m Chamber		E:\2014 Report Data\hongjirui\RF.EM6
Test Date	: 2014-08-31	Tested By	: Leo
EUT	: Turning	Model Number	: RRAP-01
Power Supply	: AC 120V/60Hz	Test Mode	: Tx mode 11n HT20 CH6
Condition	: Temp:24.5'C,Humi:55%, Press:100.1kPa	Antenna/Distance	: 2013 HF907/3m/HORIZONTAL
Memo	:		

Data: 69

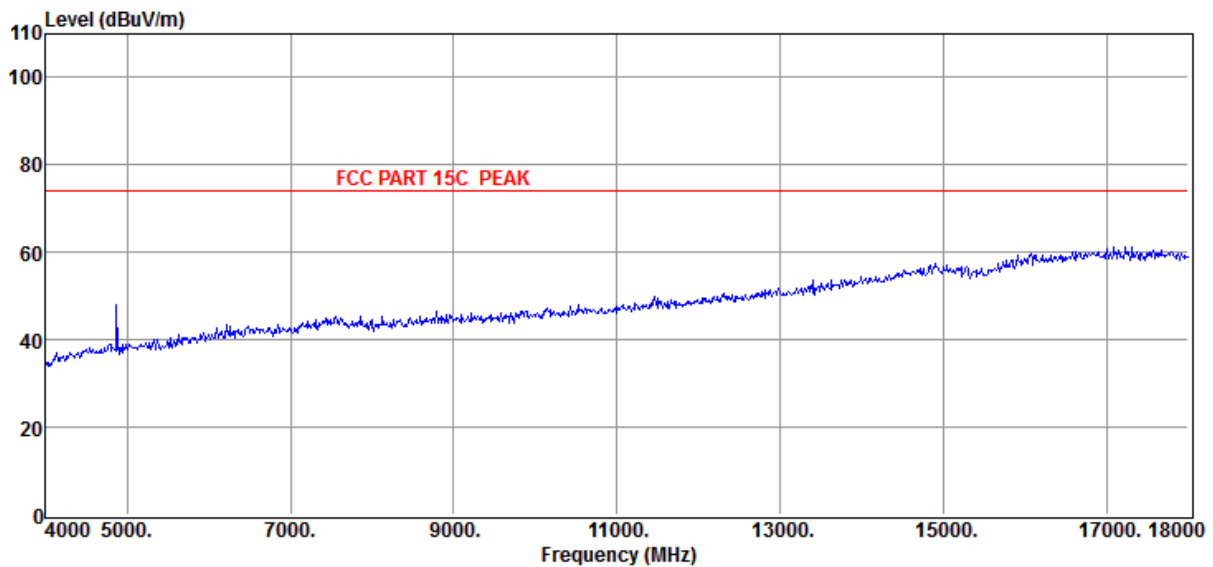

Item	Freq	Read Level	Antenna Factor	PRM Factor	Cable Loss	Result Level	Limit Line	Over Limit	Detector	Polarization
(Mark)	(MHz)	(dBμV)	(dB/m)	dB	dB	(dBμV/m)	(dBμV/m)	(dB)		

- Note: 1. Result Level = Read Level + Antenna Factor + Cable loss - PRM Factor.
 2. If Peak Result complies with AV limit, AV Result is deemed to comply with AV limit.
 3. Test setup: RBW: 1 MHz, VBW: 3 MHz, Sweep time: auto.

TR-4-E-009 Radiated Emission Test Result

Test Site	: DDT 3m Chamber	E:\2014 Report Data\hongjirui\RF.EM6
Test Date	: 2014-08-31	Tested By : Leo
EUT	: Turning	Model Number : RRAP-01
Power Supply	: AC 120V/60Hz	Test Mode : Tx mode 11n HT20 CH6
Condition	: Temp:24.5'C,Humi:55%, Press:100.1kPa	Antenna/Distance : 2013 HF907/3m/HORIZONTAL
Memo	:	

Data: 70

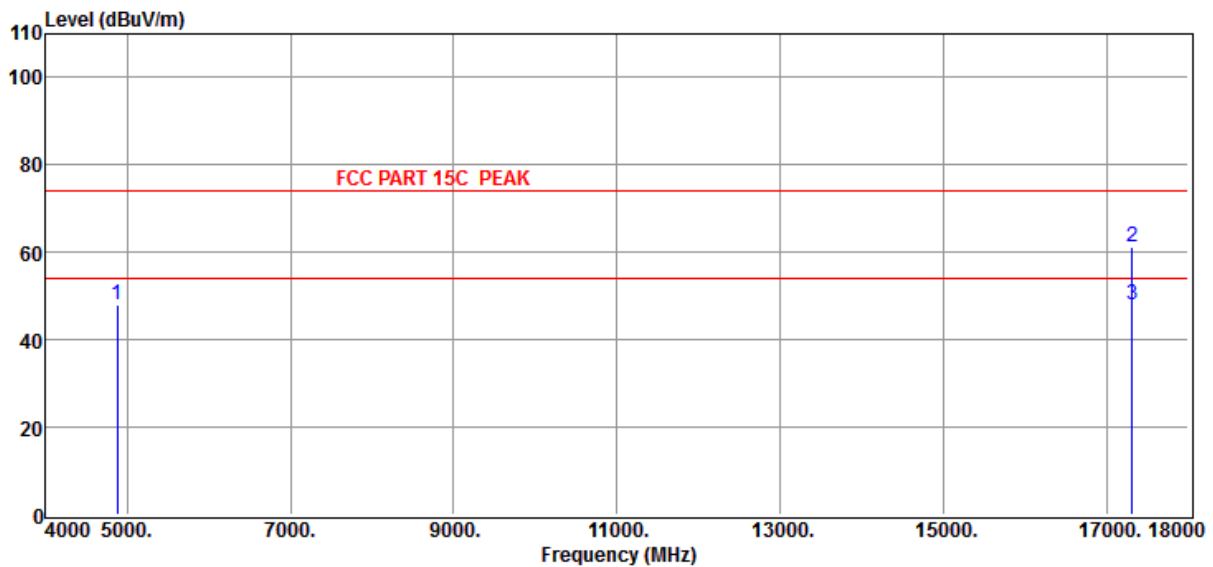

Item (Mark)	Freq (MHz)	Read Level (dBμV)	Antenna Factor (dB/m)	PRM Factor dB	Cable Loss dB	Result Level (dBμV/m)	Limit Line (dBμV/m)	Over Limit (dB)	Detector	Polarization
1	4874.00	44.58	35.51	44.04	12.04	48.09	74.00	-25.91	Peak	HORIZONTAL
2	17314.00	33.78	43.09	40.95	25.33	61.25	74.00	-12.75	Peak	HORIZONTAL
3	17314.00	20.36	43.09	40.95	25.33	47.83	54.00	-6.17	Average	HORIZONTAL

- Note: 1. Result Level = Read Level + Antenna Factor + Cable loss - PRM Factor.
 2. If Peak Result complies with AV limit, AV Result is deemed to comply with AV limit.
 3. Test setup: RBW: 1 MHz, VBW: 3 MHz, Sweep time: auto.

TR-4-E-009 Radiated Emission Test Result

Test Site	: DDT 3m Chamber	E:\2014 Report Data\hongjirui\RF.EM6
Test Date	: 2014-08-31	Tested By : Leo
EUT	: Turning	Model Number : RRAP-01
Power Supply	: AC 120V/60Hz	Test Mode : Tx mode 11n HT20 CH6
Condition	: Temp:24.5'C,Humi:55%, Press:100.1kPa	Antenna/Distance : 2013 HF907/3m/VERTICAL
Memo	:	

Data: 71

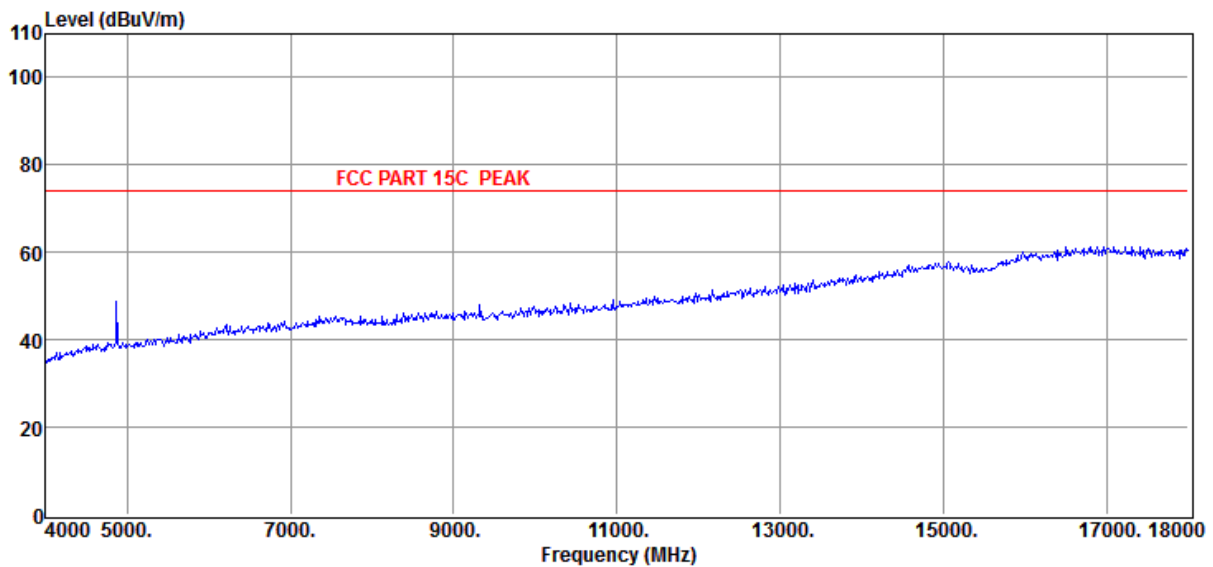

Item	Freq	Read Level	Antenna Factor	PRM Factor	Cable Loss	Result Level	Limit Line	Over Limit	Detector	Polarization
(Mark)	(MHz)	(dBμV)	(dB/m)	dB	dB	(dBμV/m)	(dBμV/m)	(dB)		

- Note: 1. Result Level = Read Level + Antenna Factor + Cable loss - PRM Factor.
 2. If Peak Result complies with AV limit, AV Result is deemed to comply with AV limit.
 3. Test setup: RBW: 1 MHz, VBW: 3 MHz, Sweep time: auto.

TR-4-E-009 Radiated Emission Test Result

Test Site : DDT 3m Chamber	E:\2014 Report Data\hongjirui\RF.EM6
Test Date : 2014-08-31	Tested By : Leo
EUT : Turning	Model Number : RRAP-01
Power Supply : AC 120V/60Hz	Test Mode : Tx mode 11n HT20 CH6
Condition : Temp:24.5'C,Humi:55%, Press:100.1kPa	Antenna/Distance : 2013 HF907/3m/VERTICAL
Memo :	

Data: 72

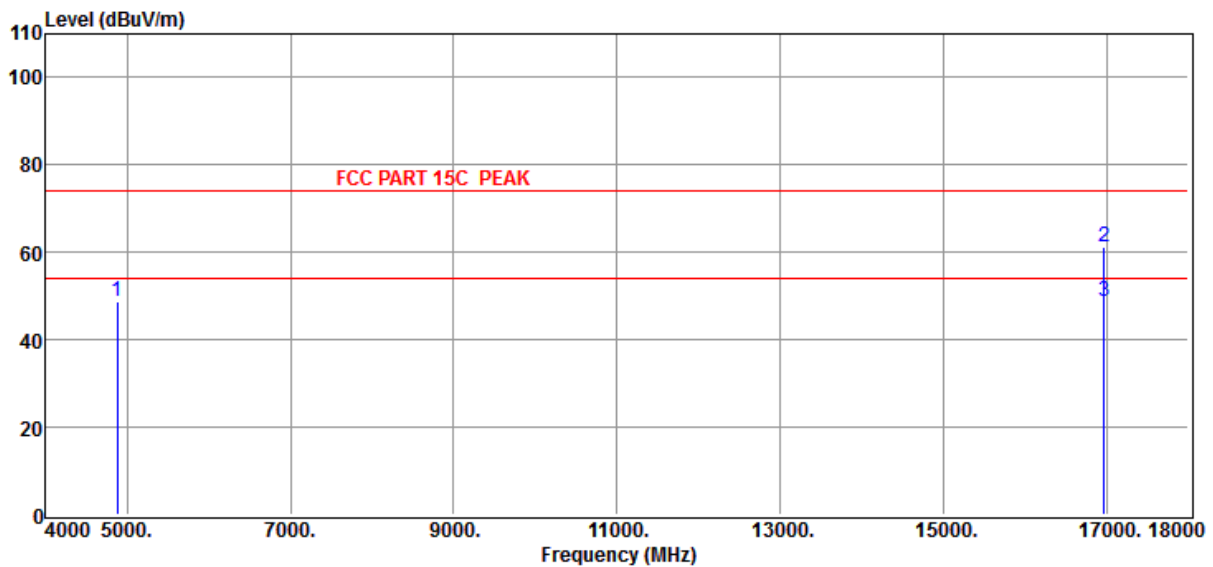

Item (Mark)	Freq (MHz)	Read Level (dBμV)	Antenna Factor (dB/m)	PRM Factor dB	Cable Loss dB	Result Level (dBμV/m)	Limit Line (dBμV/m)	Over Limit (dB)	Detector	Polarization
1	4874.00	45.40	35.51	44.04	12.04	48.91	74.00	-25.09	Peak	VERTICAL
2	16964.00	33.46	43.61	41.29	25.60	61.38	74.00	-12.62	Peak	VERTICAL
3	16964.00	20.86	43.61	41.29	25.60	48.78	54.00	-5.22	Average	VERTICAL

- Note: 1. Result Level = Read Level + Antenna Factor + Cable loss - PRM Factor.
 2. If Peak Result complies with AV limit, AV Result is deemed to comply with AV limit.
 3. Test setup: RBW: 1 MHz, VBW: 3 MHz, Sweep time: auto.

TR-4-E-009 Radiated Emission Test Result

Test Site	: DDT 3m Chamber	E:	:\2014 Report Data\hongjirui\RF.EM6
Test Date	: 2014-08-31	Tested By	: Leo
EUT	: Turning	Model Number	: RRAP-01
Power Supply	: AC 120V/60Hz	Test Mode	: Tx mode 11n HT20 CH11
Condition	: Temp:24.5'C,Humi:55%, Press:100.1kPa	Antenna/Distance	: 2013 HF907/3m/VERTICAL
Memo	:		

Data: 73

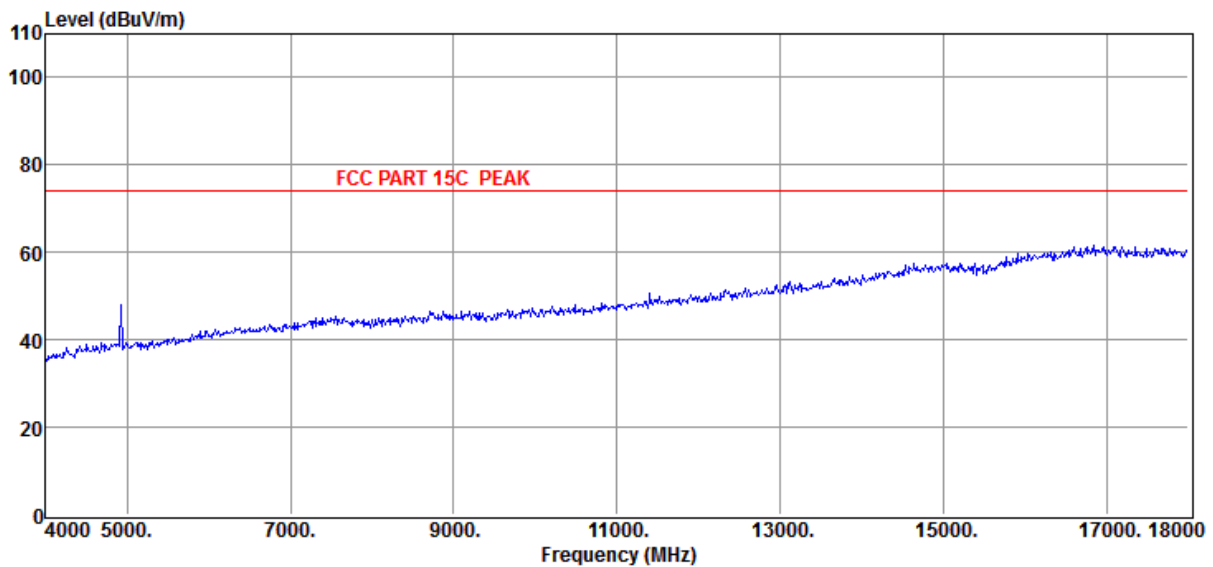

Item	Freq	Read Level	Antenna Factor	PRM Factor	Cable Loss	Result Level	Limit Line	Over Limit	Detector	Polarization
(Mark)	(MHz)	(dBμV)	(dB/m)	dB	dB	(dBμV/m)	(dBμV/m)	(dB)		

- Note: 1. Result Level = Read Level + Antenna Factor + Cable loss - PRM Factor.
 2. If Peak Result complies with AV limit, AV Result is deemed to comply with AV limit.
 3. Test setup: RBW: 1 MHz, VBW: 3 MHz, Sweep time: auto.

TR-4-E-009 Radiated Emission Test Result

Test Site : DDT 3m Chamber	E:\2014 Report Data\hongjirui\RF.EM6
Test Date : 2014-08-31	Tested By : Leo
EUT : Turning	Model Number : RRAP-01
Power Supply : AC 120V/60Hz	Test Mode : Tx mode 11n HT20 CH11
Condition : Temp:24.5'C,Humi:55%, Press:100.1kPa	Antenna/Distance : 2013 HF907/3m/VERTICAL
Memo :	

Data: 74

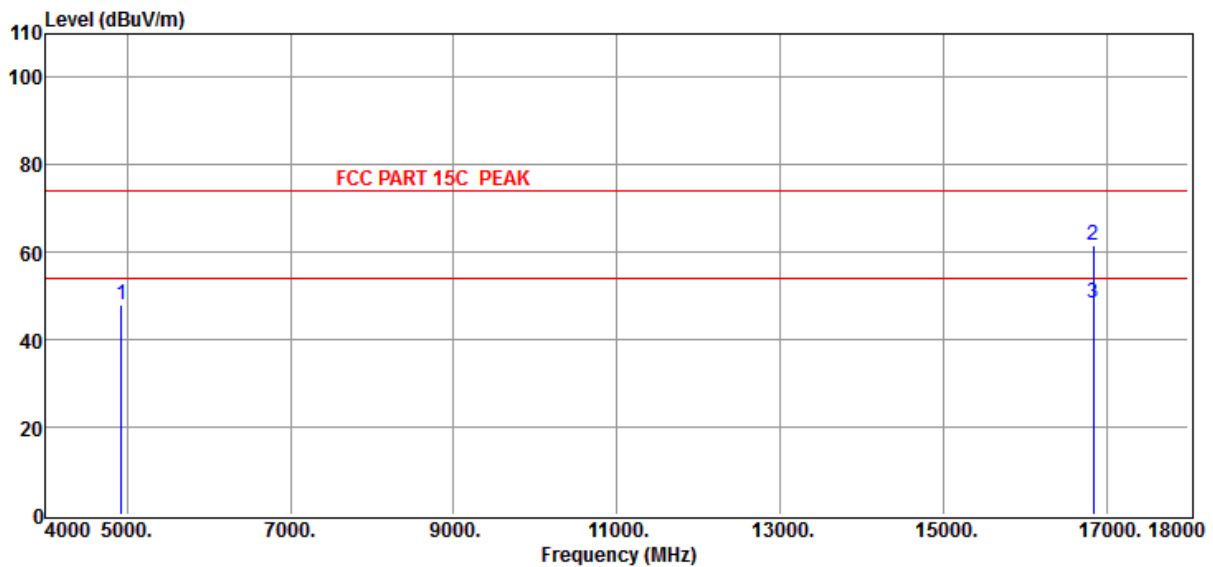

Item (Mark)	Freq (MHz)	Read Level (dBμV)	Antenna Factor (dB/m)	PRM Factor dB	Cable Loss dB	Result Level (dBμV/m)	Limit Line (dBμV/m)	Over Limit (dB)	Detector	Polarization
1	4924.00	44.48	35.59	44.02	12.02	48.07	74.00	-25.93	Peak	VERTICAL
2	16838.00	33.72	43.63	41.27	25.60	61.68	74.00	-12.32	Peak	VERTICAL
3	16838.00	20.37	43.63	41.27	25.60	48.33	54.00	-5.67	Average	VERTICAL

- Note: 1. Result Level = Read Level + Antenna Factor + Cable loss - PRM Factor.
 2. If Peak Result complies with AV limit, AV Result is deemed to comply with AV limit.
 3. Test setup: RBW: 1 MHz, VBW: 3 MHz, Sweep time: auto.

TR-4-E-009 Radiated Emission Test Result

Test Site	: DDT 3m Chamber	E:\2014 Report Data\hongjirui\RF.EM6
Test Date	: 2014-08-31	Tested By : Leo
EUT	: Turning	Model Number : RRAP-01
Power Supply	: AC 120V/60Hz	Test Mode : Tx mode 11n HT20 CH11
Condition	: Temp:24.5'C,Humi:55%, Press:100.1kPa	Antenna/Distance : 2013 HF907/3m/HORIZONTAL
Memo	:	

Data: 75

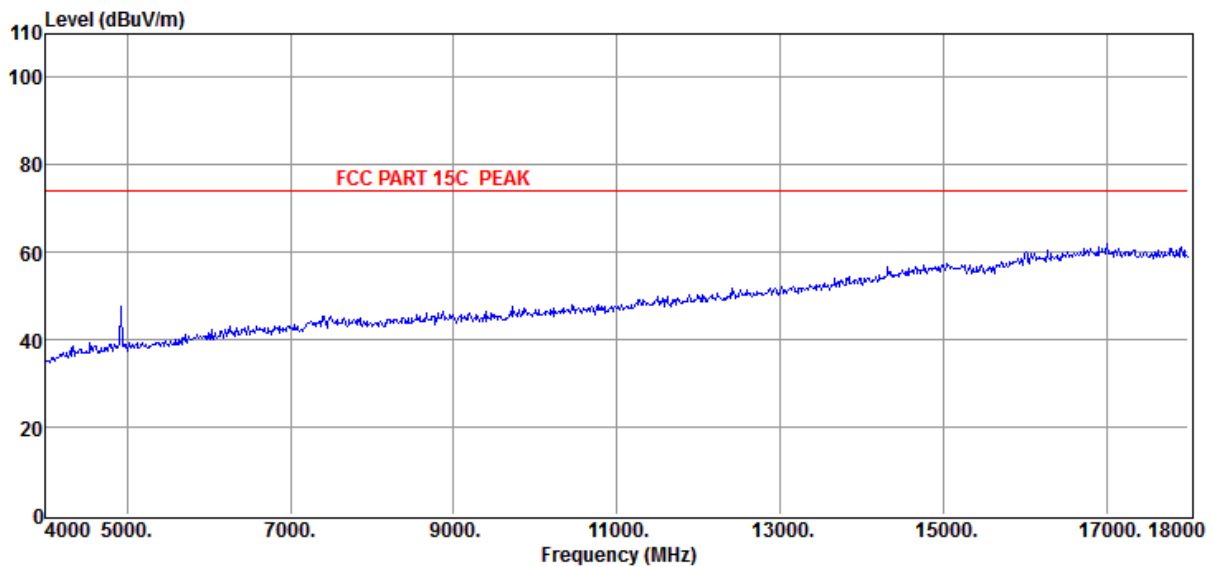

Item	Freq	Read Level	Antenna Factor	PRM Factor	Cable Loss	Result Level	Limit Line	Over Limit	Detector	Polarization
(Mark)	(MHz)	(dBμV)	(dB/m)	dB	dB	(dBμV/m)	(dBμV/m)	(dB)		

- Note: 1. Result Level = Read Level + Antenna Factor + Cable loss - PRM Factor.
 2. If Peak Result complies with AV limit, AV Result is deemed to comply with AV limit.
 3. Test setup: RBW: 1 MHz, VBW: 3 MHz, Sweep time: auto.

TR-4-E-009 Radiated Emission Test Result

Test Site	: DDT 3m Chamber	E:	:\2014 Report Data\hongjirui\RF.EM6
Test Date	: 2014-08-31	Tested By	: Leo
EUT	: Turning	Model Number	: RRAP-01
Power Supply	: AC 120V/60Hz	Test Mode	: Tx mode 11n HT20 CH11
Condition	: Temp:24.5'C,Humi:55%, Press:100.1kPa	Antenna/Distance	: 2013 HF907/3m/HORIZONTAL
Memo	:		

Data: 76

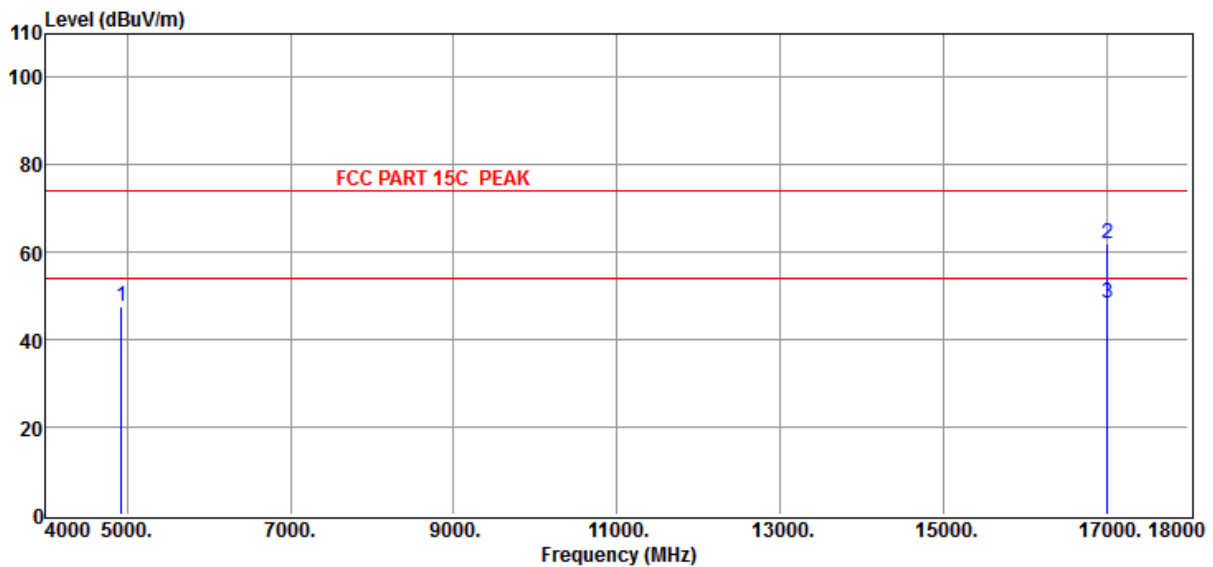

Item (Mark)	Freq (MHz)	Read Level (dBμV)	Antenna Factor (dB/m)	PRM Factor dB	Cable Loss dB	Result Level (dBμV/m)	Limit Line (dBμV/m)	Over Limit (dB)	Detector	Polarization
1	4924.00	44.20	35.59	44.02	12.02	47.79	74.00	-26.21	Peak	HORIZONTAL
2	17006.00	34.25	43.57	41.30	25.60	62.12	74.00	-11.88	Peak	HORIZONTAL
3	17006.00	20.45	43.57	41.30	25.60	48.32	54.00	-5.68	Average	HORIZONTAL

- Note: 1. Result Level = Read Level + Antenna Factor + Cable loss - PRM Factor.
 2. If Peak Result complies with AV limit, AV Result is deemed to comply with AV limit.
 3. Test setup: RBW: 1 MHz, VBW: 3 MHz, Sweep time: auto.

TR-4-E-009 Radiated Emission Test Result

Test Site	: DDT 3m Chamber	E:\2014 Report Data\hongjirui\RF.EM6
Test Date	: 2014-08-31	Tested By : Leo
EUT	: Turning	Model Number : RRAP-01
Power Supply	: AC 120V/60Hz	Test Mode : Tx mode 11n HT40 CH3
Condition	: Temp:24.5'C,Humi:55%, Press:100.1kPa	Antenna/Distance : 2013 HF907/3m/HORIZONTAL
Memo	:	

Data: 77

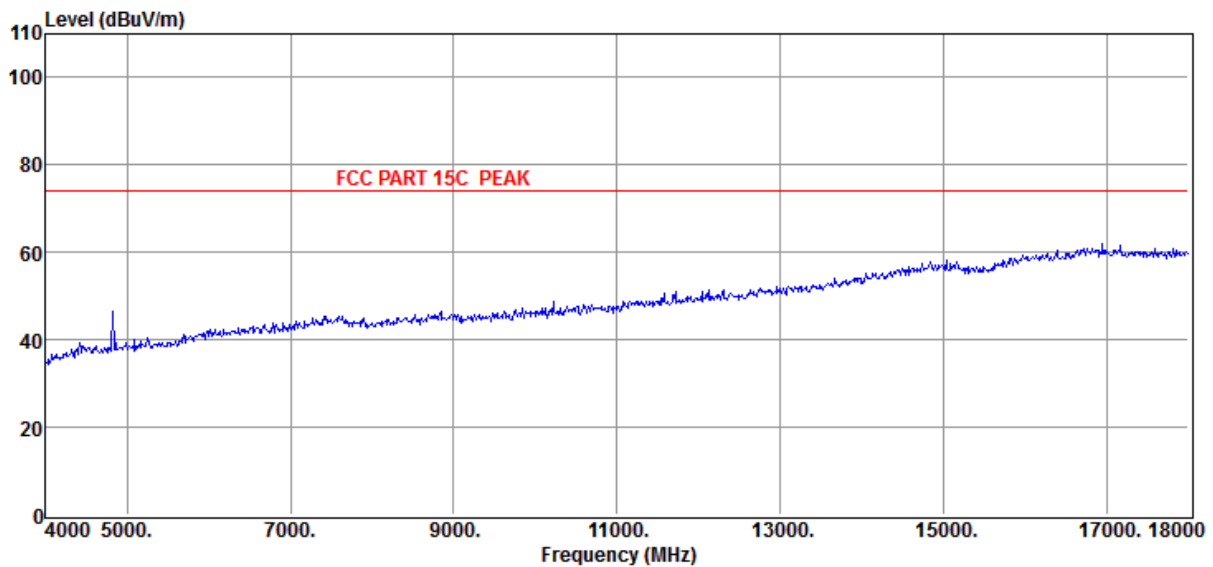

Item	Freq	Read Level	Antenna Factor	PRM Factor	Cable Loss	Result Level	Limit Line	Over Limit	Detector	Polarization
(Mark)	(MHz)	(dBμV)	(dB/m)	dB	dB	(dBμV/m)	(dBμV/m)	(dB)		

- Note: 1. Result Level = Read Level + Antenna Factor + Cable loss - PRM Factor.
 2. If Peak Result complies with AV limit, AV Result is deemed to comply with AV limit.
 3. Test setup: RBW: 1 MHz, VBW: 3 MHz, Sweep time: auto.

TR-4-E-009 Radiated Emission Test Result

Test Site : DDT 3m Chamber	E:\2014 Report Data\hongjirui\RF.EM6
Test Date : 2014-08-31	Tested By : Leo
EUT : Turning	Model Number : RRAP-01
Power Supply : AC 120V/60Hz	Test Mode : Tx mode 11n HT40 CH3
Condition : Temp:24.5'C,Humi:55%, Press:100.1kPa	Antenna/Distance : 2013 HF907/3m/HORIZONTAL
Memo :	

Data: 78

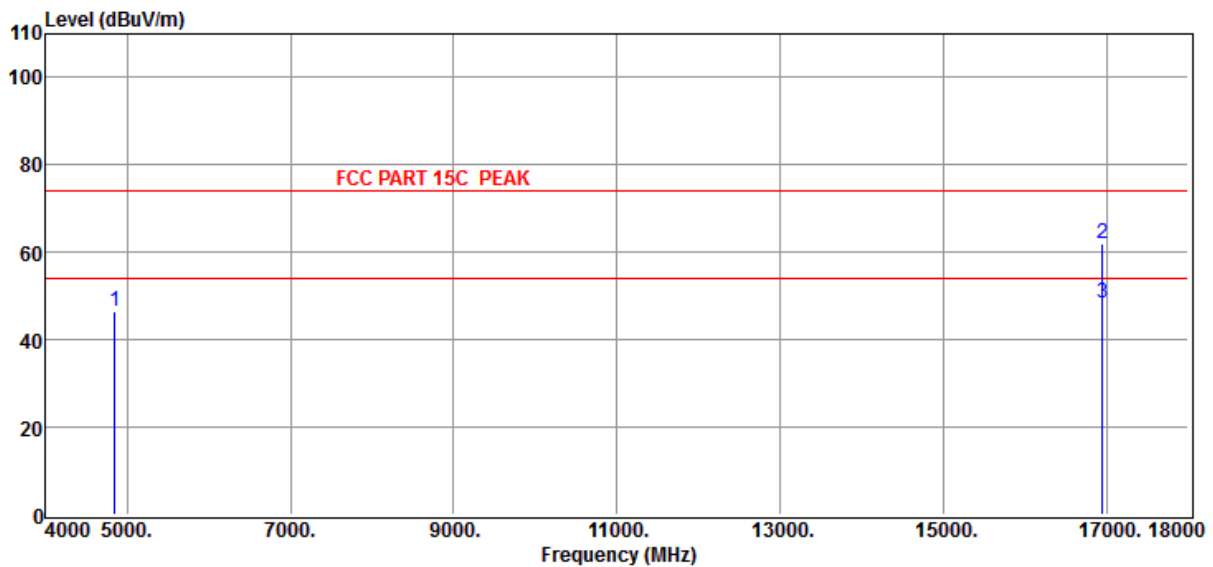

Item (Mark)	Freq (MHz)	Read Level (dBμV)	Antenna Factor (dB/m)	PRM Factor dB	Cable Loss dB	Result Level (dBμV/m)	Limit Line (dBμV/m)	Over Limit (dB)	Detector	Polarization
1	4844.00	42.90	35.45	44.04	12.07	46.38	74.00	-27.62	Peak	HORIZONTAL
2	16950.00	33.91	43.61	41.28	25.60	61.84	74.00	-12.16	Peak	HORIZONTAL
3	16950.00	20.58	43.61	41.28	25.60	48.51	54.00	-5.49	Average	HORIZONTAL

- Note: 1. Result Level = Read Level + Antenna Factor + Cable loss - PRM Factor.
 2. If Peak Result complies with AV limit, AV Result is deemed to comply with AV limit.
 3. Test setup: RBW: 1 MHz, VBW: 3 MHz, Sweep time: auto.

TR-4-E-009 Radiated Emission Test Result

Test Site	: DDT 3m Chamber	E:\2014 Report Data\hongjirui\RF.EM6
Test Date	: 2014-08-31	Tested By : Leo
EUT	: Turning	Model Number : RRAP-01
Power Supply	: AC 120V/60Hz	Test Mode : Tx mode 11n HT40 CH3
Condition	: Temp:24.5'C,Humi:55%, Press:100.1kPa	Antenna/Distance : 2013 HF907/3m/VERTICAL
Memo	:	

Data: 79

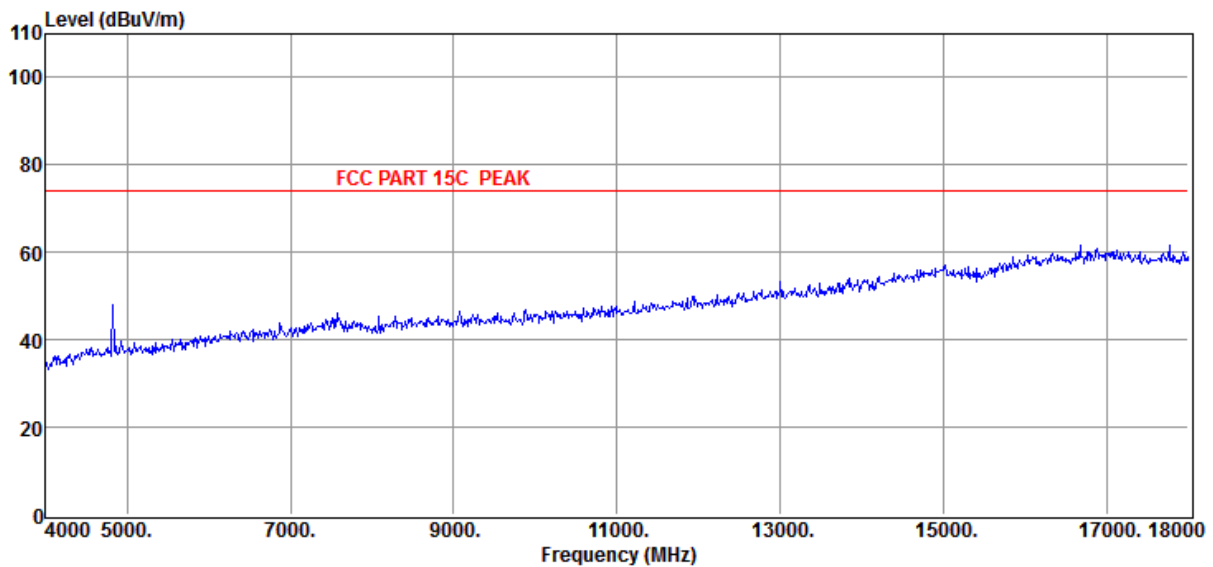

Item	Freq	Read Level	Antenna Factor	PRM Factor	Cable Loss	Result Level	Limit Line	Over Limit	Detector	Polarization
(Mark)	(MHz)	(dBμV)	(dB/m)	dB	dB	(dBμV/m)	(dBμV/m)	(dB)		

- Note: 1. Result Level = Read Level + Antenna Factor + Cable loss - PRM Factor.
 2. If Peak Result complies with AV limit, AV Result is deemed to comply with AV limit.
 3. Test setup: RBW: 1 MHz, VBW: 3 MHz, Sweep time: auto.

TR-4-E-009 Radiated Emission Test Result

Test Site : DDT 3m Chamber	E:\2014 Report Data\hongjirui\RF.EM6
Test Date : 2014-08-31	Tested By : Leo
EUT : Turning	Model Number : RRAP-01
Power Supply : AC 120V/60Hz	Test Mode : Tx mode 11n HT40 CH3
Condition : Temp:24.5'C,Humi:55%, Press:100.1kPa	Antenna/Distance : 2013 HF907/3m/VERTICAL
Memo :	

Data: 80

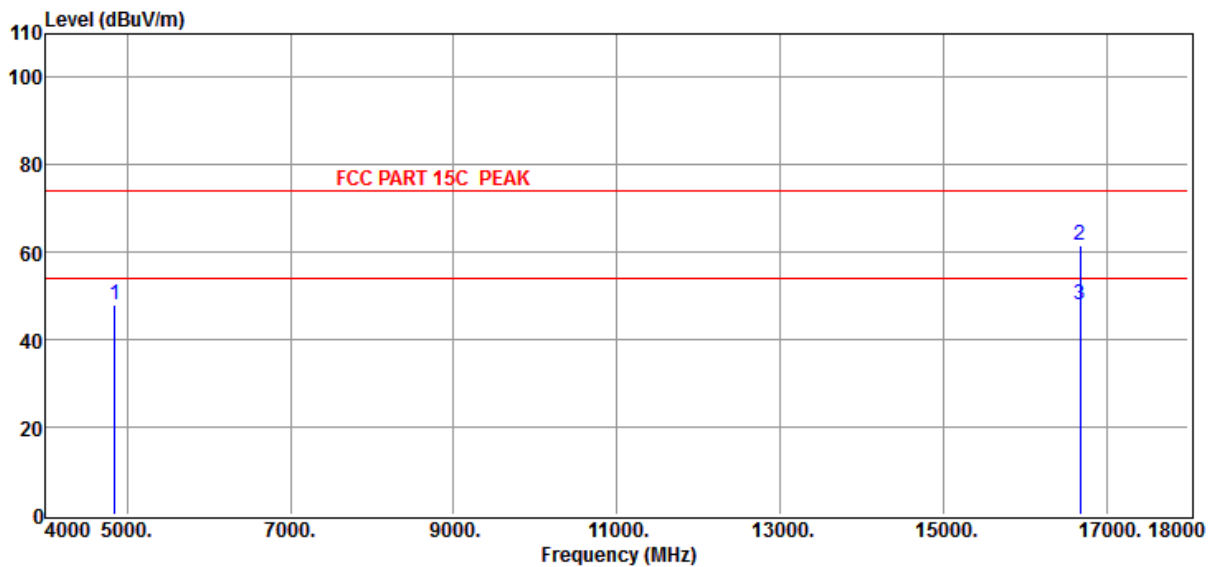

Item (Mark)	Freq (MHz)	Read Level (dBμV)	Antenna Factor (dB/m)	PRM Factor dB	Cable Loss dB	Result Level (dBμV/m)	Limit Line (dBμV/m)	Over Limit (dB)	Detector	Polarization
1	4844.00	44.38	35.45	44.04	12.07	47.86	74.00	-26.14	Peak	VERTICAL
2	16670.00	34.04	43.67	41.21	25.00	61.50	74.00	-12.50	Peak	VERTICAL
3	16670.00	20.48	43.67	41.21	25.00	47.94	54.00	-6.06	Average	VERTICAL

- Note: 1. Result Level = Read Level + Antenna Factor + Cable loss - PRM Factor.
 2. If Peak Result complies with AV limit, AV Result is deemed to comply with AV limit.
 3. Test setup: RBW: 1 MHz, VBW: 3 MHz, Sweep time: auto.

TR-4-E-009 Radiated Emission Test Result

Test Site	: DDT 3m Chamber	E:	:\2014 Report Data\hongjirui\RF.EM6
Test Date	: 2014-08-31	Tested By	: Leo
EUT	: Turning	Model Number	: RRAP-01
Power Supply	: AC 120V/60Hz	Test Mode	: Tx mode 11n HT40 CH6
Condition	: Temp:24.5'C,Humi:55%, Press:100.1kPa	Antenna/Distance	: 2013 HF907/3m/VERTICAL
Memo	:		

Data: 81

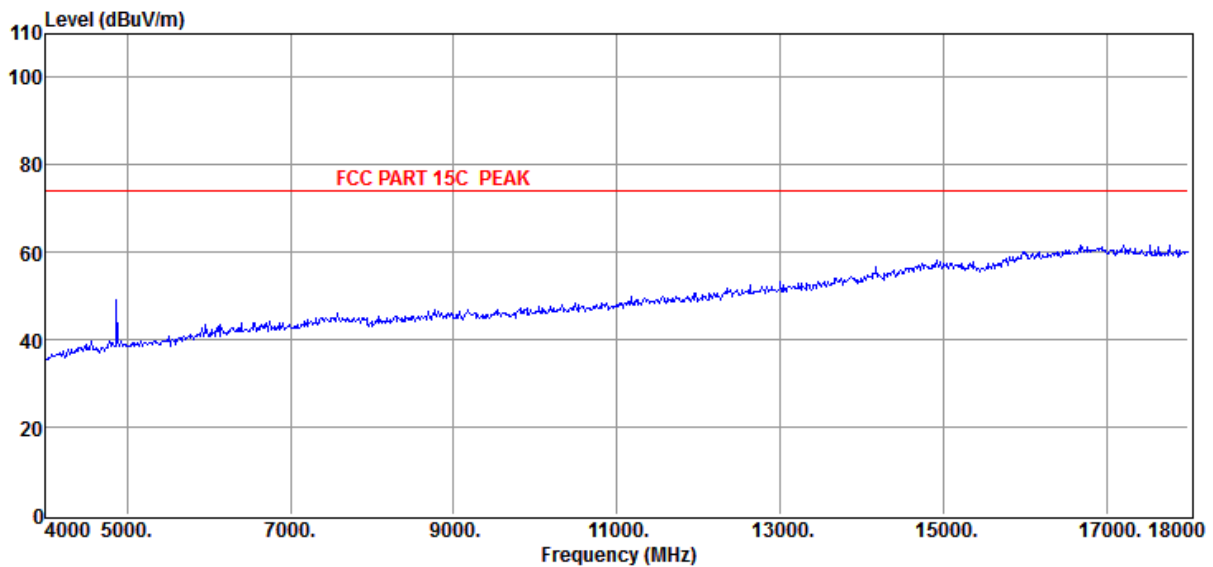

Item	Freq	Read Level	Antenna Factor	PRM Factor	Cable Loss	Result Level	Limit Line	Over Limit	Detector	Polarization
(Mark)	(MHz)	(dBμV)	(dB/m)	dB	dB	(dBμV/m)	(dBμV/m)	(dB)		

- Note: 1. Result Level = Read Level + Antenna Factor + Cable loss - PRM Factor.
 2. If Peak Result complies with AV limit, AV Result is deemed to comply with AV limit.
 3. Test setup: RBW: 1 MHz, VBW: 3 MHz, Sweep time: auto.

TR-4-E-009 Radiated Emission Test Result

Test Site : DDT 3m Chamber	E:\2014 Report Data\hongjirui\RF.EM6
Test Date : 2014-08-31	Tested By : Leo
EUT : Turning	Model Number : RRAP-01
Power Supply : AC 120V/60Hz	Test Mode : Tx mode 11n HT40 CH6
Condition : Temp:24.5'C,Humi:55%, Press:100.1kPa	Antenna/Distance : 2013 HF907/3m/VERTICAL
Memo :	

Data: 82

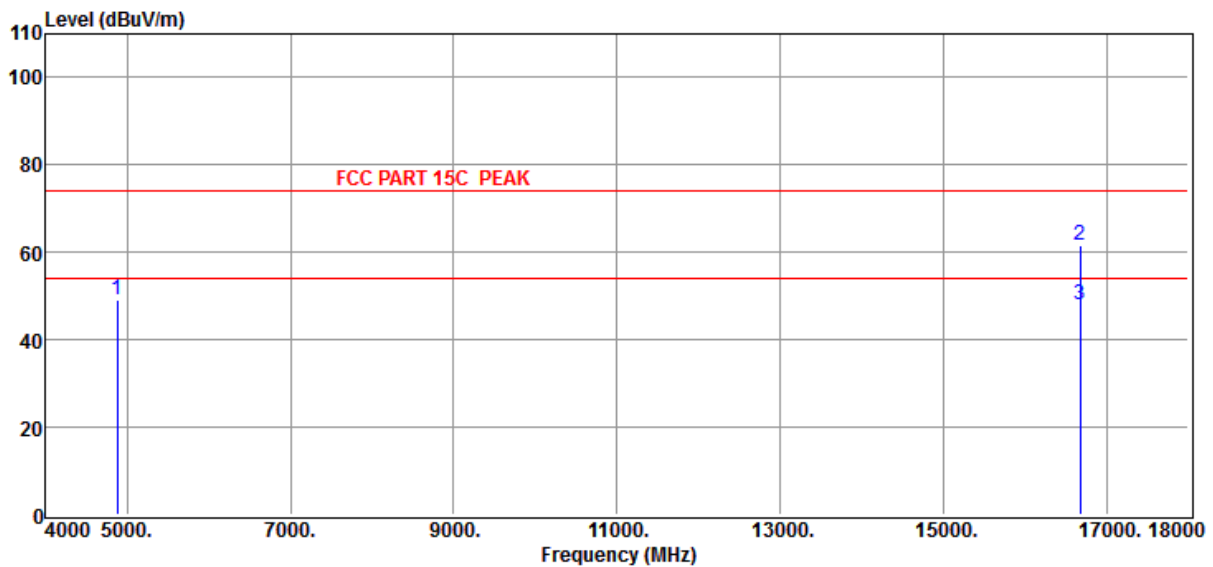

Item (Mark)	Freq (MHz)	Read Level (dBμV)	Antenna Factor (dB/m)	PRM Factor dB	Cable Loss dB	Result Level (dBμV/m)	Limit Line (dBμV/m)	Over Limit (dB)	Detector	Polarization
1	4874.00	45.45	35.51	44.04	12.04	48.96	74.00	-25.04	Peak	VERTICAL
2	16670.00	34.04	43.67	41.21	25.00	61.50	74.00	-12.50	Peak	VERTICAL
3	16670.00	20.54	43.67	41.21	25.00	48.00	54.00	-6.00	Average	VERTICAL

- Note: 1. Result Level = Read Level + Antenna Factor + Cable loss - PRM Factor.
 2. If Peak Result complies with AV limit, AV Result is deemed to comply with AV limit.
 3. Test setup: RBW: 1 MHz, VBW: 3 MHz, Sweep time: auto.

TR-4-E-009 Radiated Emission Test Result

Test Site	: DDT 3m Chamber	E:\2014 Report Data\hongjirui\RF.EM6
Test Date	: 2014-08-31	Tested By : Leo
EUT	: Turning	Model Number : RRAP-01
Power Supply	: AC 120V/60Hz	Test Mode : Tx mode 11n HT40 CH6
Condition	: Temp:24.5'C,Humi:55%, Press:100.1kPa	Antenna/Distance : 2013 HF907/3m/HORIZONTAL
Memo	:	

Data: 83

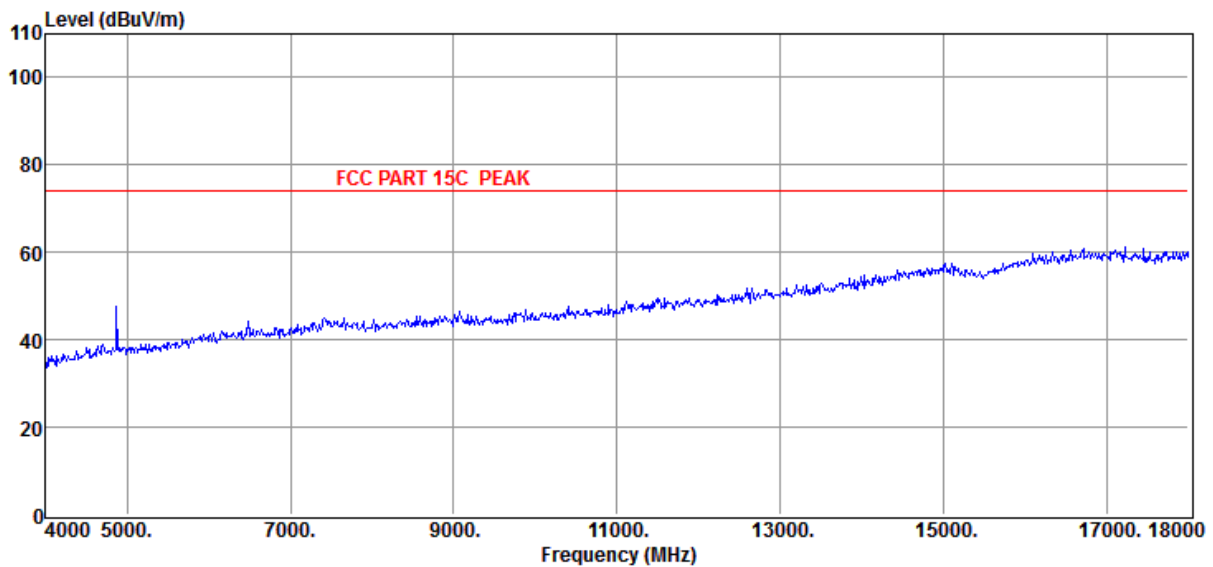

Item	Freq	Read Level	Antenna Factor	PRM Factor	Cable Loss	Result Level	Limit Line	Over Limit	Detector	Polarization
(Mark)	(MHz)	(dBμV)	(dB/m)	dB	dB	(dBμV/m)	(dBμV/m)	(dB)		

- Note: 1. Result Level = Read Level + Antenna Factor + Cable loss - PRM Factor.
 2. If Peak Result complies with AV limit, AV Result is deemed to comply with AV limit.
 3. Test setup: RBW: 1 MHz, VBW: 3 MHz, Sweep time: auto.

TR-4-E-009 Radiated Emission Test Result

Test Site	: DDT 3m Chamber	E:\2014 Report Data\hongjirui\RF.EM6
Test Date	: 2014-08-31	Tested By : Leo
EUT	: Turning	Model Number : RRAP-01
Power Supply	: AC 120V/60Hz	Test Mode : Tx mode 11n HT40 CH6
Condition	: Temp:24.5'C,Humi:55%, Press:100.1kPa	Antenna/Distance : 2013 HF907/3m/HORIZONTAL
Memo	:	

Data: 84

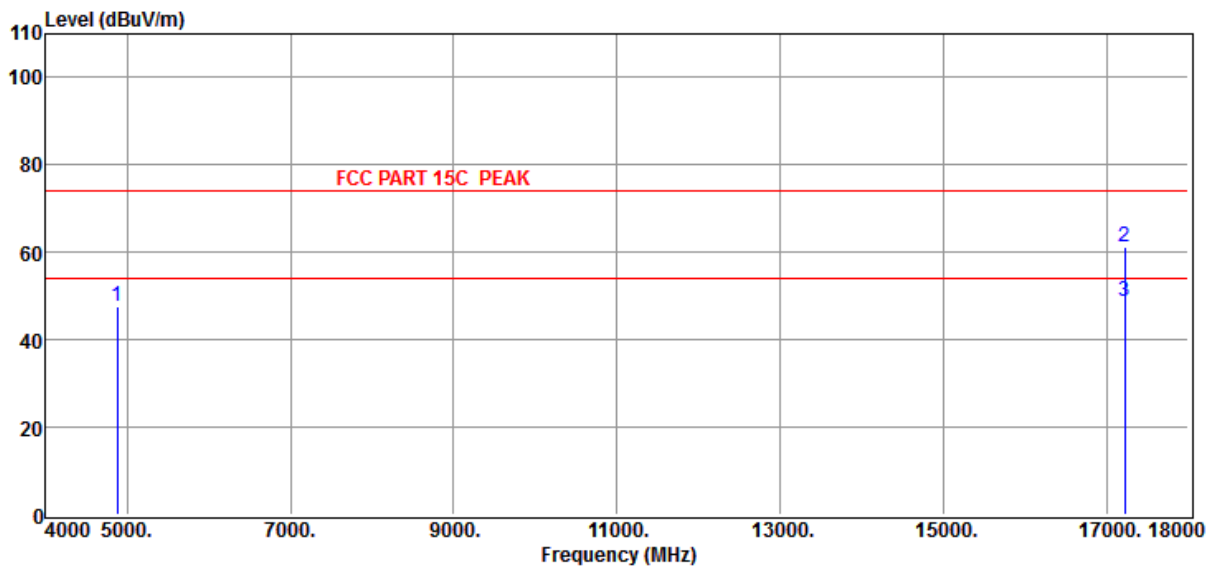

Item (Mark)	Freq (MHz)	Read Level (dBμV)	Antenna Factor (dB/m)	PRM Factor dB	Cable Loss dB	Result Level (dBμV/m)	Limit Line (dBμV/m)	Over Limit (dB)	Detector	Polarization
1	4874.00	44.04	35.51	44.04	12.04	47.55	74.00	-26.45	Peak	HORIZONTAL
2	17216.00	33.50	43.25	41.10	25.47	61.12	74.00	-12.88	Peak	HORIZONTAL
3	17216.00	21.03	43.25	41.10	25.47	48.65	54.00	-5.35	Average	HORIZONTAL

- Note: 1. Result Level = Read Level + Antenna Factor + Cable loss - PRM Factor.
 2. If Peak Result complies with AV limit, AV Result is deemed to comply with AV limit.
 3. Test setup: RBW: 1 MHz, VBW: 3 MHz, Sweep time: auto.

TR-4-E-009 Radiated Emission Test Result

Test Site	: DDT 3m Chamber	E:\2014 Report Data\hongjirui\RF.EM6
Test Date	: 2014-08-31	Tested By : Leo
EUT	: Turning	Model Number : RRAP-01
Power Supply	: AC 120V/60Hz	Test Mode : Tx mode 11n HT40 CH9
Condition	: Temp:24.5'C,Humi:55%, Press:100.1kPa	Antenna/Distance : 2013 HF907/3m/HORIZONTAL
Memo	:	

Data: 85

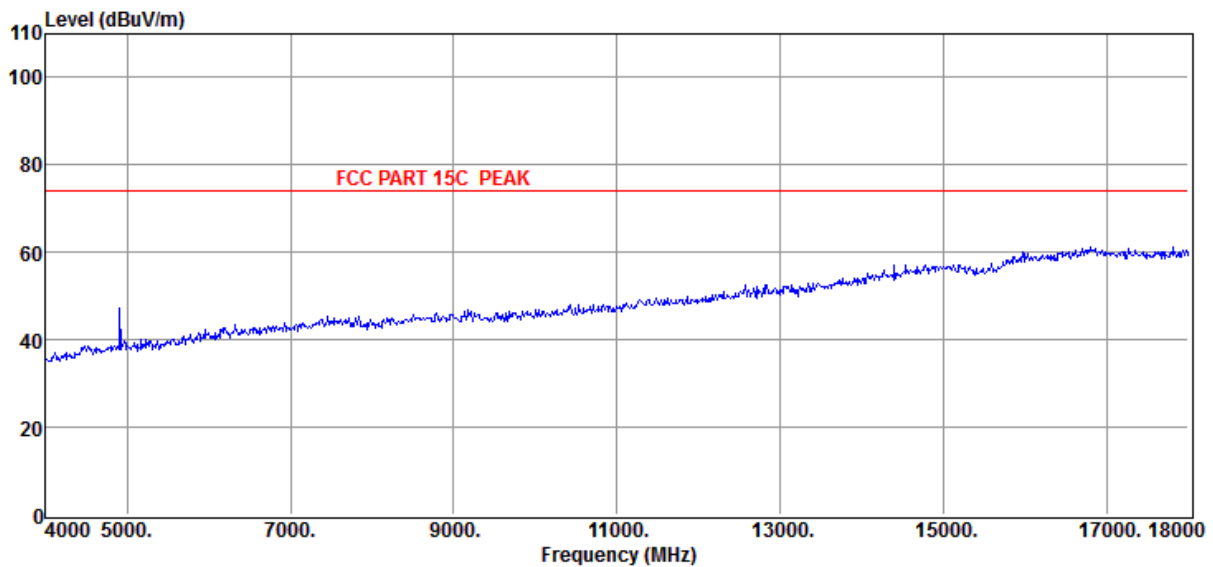

Item	Freq	Read Level	Antenna Factor	PRM Factor	Cable Loss	Result Level	Limit Line	Over Limit	Detector	Polarization
(Mark)	(MHz)	(dBμV)	(dB/m)	dB	dB	(dBμV/m)	(dBμV/m)	(dB)		

- Note: 1. Result Level = Read Level + Antenna Factor + Cable loss - PRM Factor.
 2. If Peak Result complies with AV limit, AV Result is deemed to comply with AV limit.
 3. Test setup: RBW: 1 MHz, VBW: 3 MHz, Sweep time: auto.

TR-4-E-009 Radiated Emission Test Result

Test Site	: DDT 3m Chamber	E:\2014 Report Data\hongjirui\RF.EM6
Test Date	: 2014-08-31	Tested By : Leo
EUT	: Turning	Model Number : RRAP-01
Power Supply	: AC 120V/60Hz	Test Mode : Tx mode 11n HT40 CH9
Condition	: Temp:24.5'C,Humi:55%, Press:100.1kPa	Antenna/Distance : 2013 HF907/3m/HORIZONTAL
Memo	:	

Data: 86

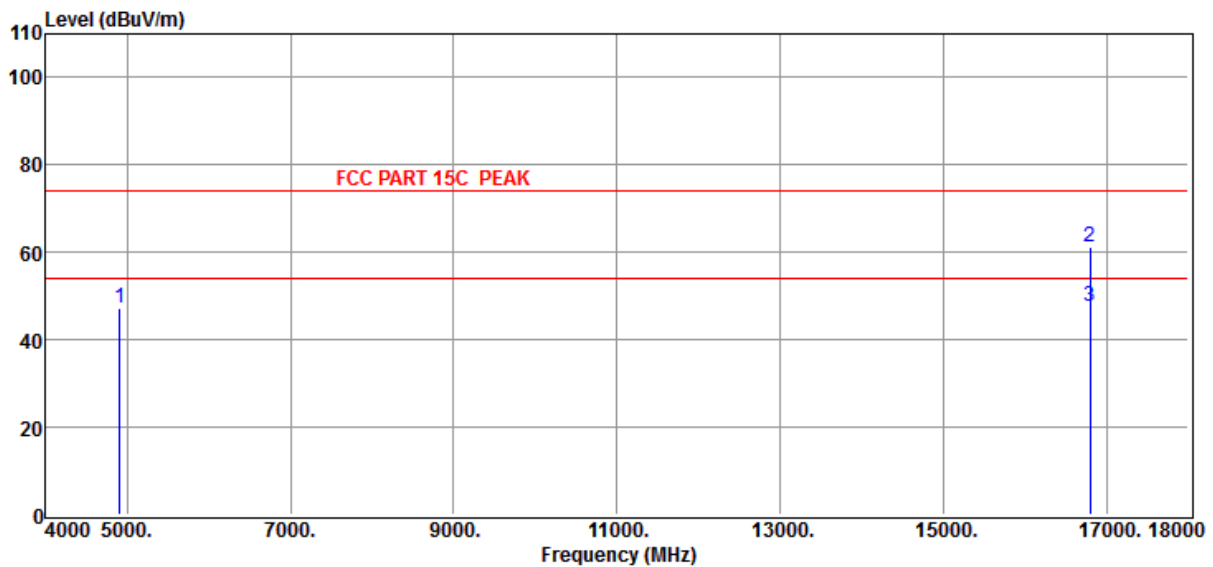

Item (Mark)	Freq (MHz)	Read Level (dBμV)	Antenna Factor (dB/m)	PRM Factor dB	Cable Loss dB	Result Level (dBμV/m)	Limit Line (dBμV/m)	Over Limit (dB)	Detector	Polarization
1	4904.00	43.78	35.56	44.03	12.04	47.35	74.00	-26.65	Peak	HORIZONTAL
2	16796.00	33.76	43.64	41.26	25.00	61.14	74.00	-12.86	Peak	HORIZONTAL
3	16796.00	20.36	43.64	41.26	25.00	47.74	54.00	-6.26	Average	HORIZONTAL

- Note: 1. Result Level = Read Level + Antenna Factor + Cable loss - PRM Factor.
 2. If Peak Result complies with AV limit, AV Result is deemed to comply with AV limit.
 3. Test setup: RBW: 1 MHz, VBW: 3 MHz, Sweep time: auto.

TR-4-E-009 Radiated Emission Test Result

Test Site	: DDT 3m Chamber	E:\2014 Report Data\hongjirui\RF.EM6
Test Date	: 2014-08-31	Tested By : Leo
EUT	: Turning	Model Number : RRAP-01
Power Supply	: AC 120V/60Hz	Test Mode : Tx mode 11n HT40 CH9
Condition	: Temp:24.5'C,Humi:55%, Press:100.1kPa	Antenna/Distance : 2013 HF907/3m/VERTICAL
Memo	:	

Data: 87

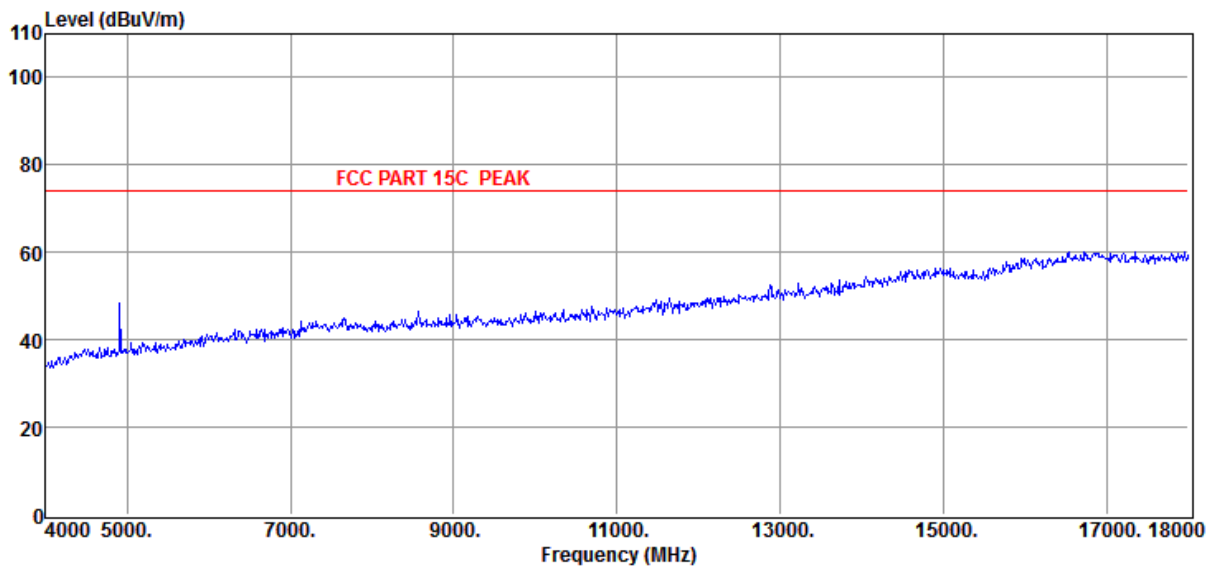

Item	Freq	Read Level	Antenna Factor	PRM Factor	Cable Loss	Result Level	Limit Line	Over Limit	Detector	Polarization
(Mark)	(MHz)	(dBμV)	(dB/m)	dB	dB	(dBμV/m)	(dBμV/m)	(dB)		

- Note: 1. Result Level = Read Level + Antenna Factor + Cable loss - PRM Factor.
 2. If Peak Result complies with AV limit, AV Result is deemed to comply with AV limit.
 3. Test setup: RBW: 1 MHz, VBW: 3 MHz, Sweep time: auto.

TR-4-E-009 Radiated Emission Test Result

Test Site : DDT 3m Chamber	E:\2014 Report Data\hongjirui\RF.EM6
Test Date : 2014-08-31	Tested By : Leo
EUT : Turning	Model Number : RRAP-01
Power Supply : AC 120V/60Hz	Test Mode : Tx mode 11n HT40 CH9
Condition : Temp:24.5'C,Humi:55%, Press:100.1kPa	Antenna/Distance : 2013 HF907/3m/VERTICAL
Memo :	

Data: 88

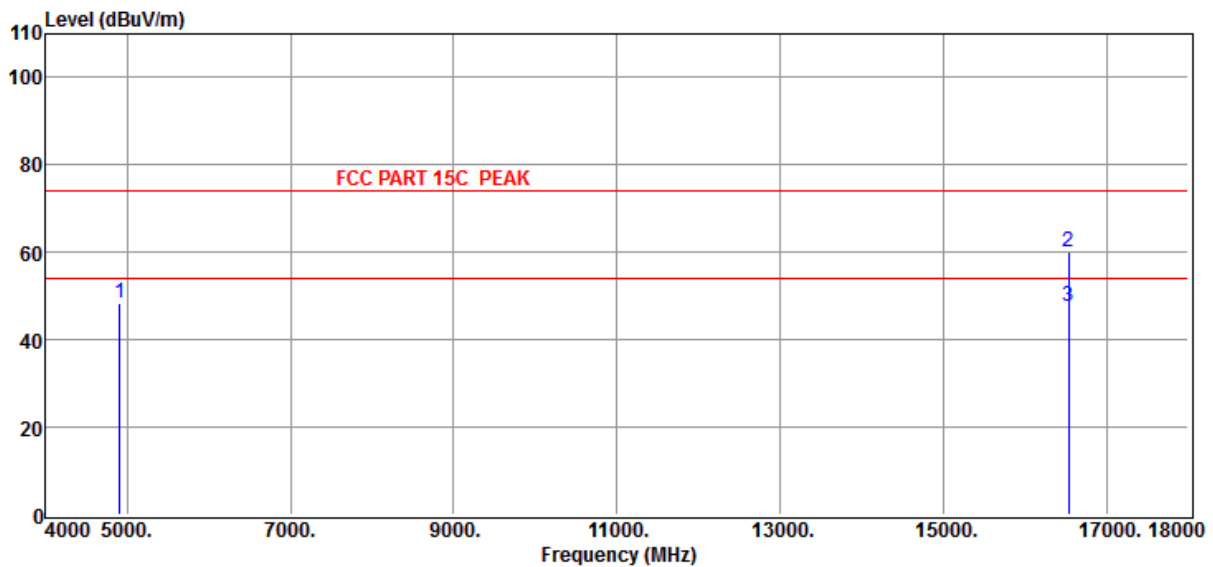

Item (Mark)	Freq (MHz)	Read Level (dBμV)	Antenna Factor (dB/m)	PRM Factor dB	Cable Loss dB	Result Level (dBμV/m)	Limit Line (dBμV/m)	Over Limit (dB)	Detector	Polarization
1	4904.00	44.82	35.56	44.03	12.04	48.39	74.00	-25.61	Peak	VERTICAL
2	16530.00	33.27	43.69	41.18	24.40	60.18	74.00	-13.82	Peak	VERTICAL
3	16530.00	20.87	43.69	41.18	24.40	47.78	54.00	-6.22	Average	VERTICAL

- Note: 1. Result Level = Read Level + Antenna Factor + Cable loss - PRM Factor.
 2. If Peak Result complies with AV limit, AV Result is deemed to comply with AV limit.
 3. Test setup: RBW: 1 MHz, VBW: 3 MHz, Sweep time: auto.

8. Band Edge Compliance

8.1. Test equipment

Item	Equipment	Manufacturer	Model No.	Serial No.	Last Cal.	Cal. Interval
1	EMI Test Receiver	R&S	ESU8	100316	2013/11/13	1 Year
2	Spectrum analyzer	R&S	FSU	1166.1660.26	2013/11/13	1 Year
3	Trilog Broadband Antenna	Schwarzbeck	VULB9163	9163-462	2013/11/13	1 Year
4	Double Ridged Horn Antenna	R&S	HF907	100276	2013/11/13	1 Year
5	Pre-Amplifier	R&S	SCU-01	10049	2013/11/13	1 Year
6	Pre-amplifier	A.H.	PAM0-0118	360	2013/11/13	1 Year
7	RF Cable	R&S	R01	10403	2013/11/13	1 Year
8	RF Cable	R&S	R02	10512	2013/11/13	1 Year

8.2. Block diagram of test setup

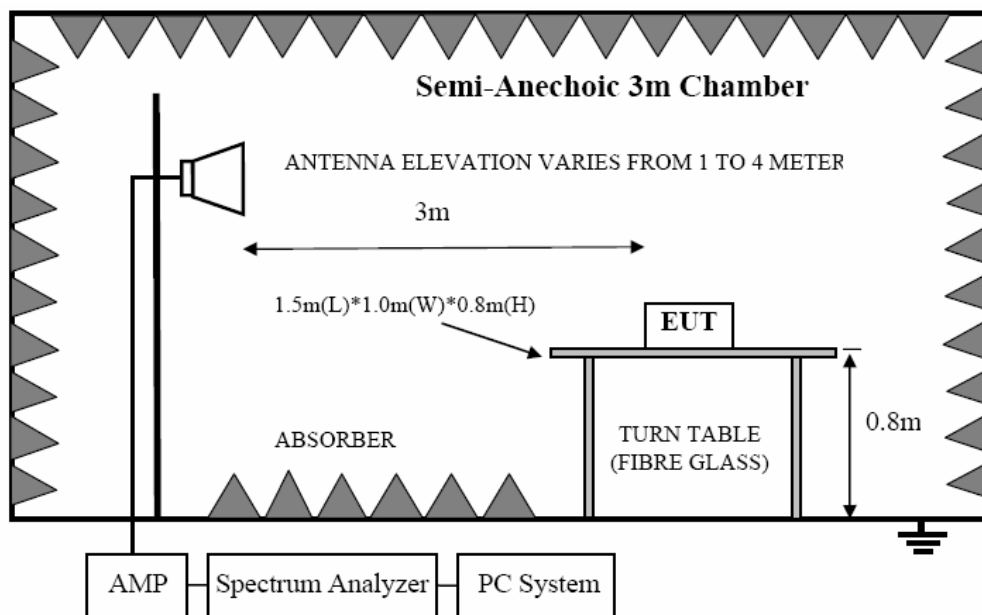

8.3. Limit

All the lower and upper band-edges emissions appearing within 2310MHz to 2390MHz and 2483.5MHz to 2500MHz restricted frequency bands shall not exceed the limits shown in 15.209, all the other emissions outside operation frequency band 2400MHz to 2483.5MHz and 5725MHz to 5850MHz shall be at least 20dB below the fundamental emissions, or comply with 15.209 limits.

8.4. Test Procedure

Same with clause 8.4 except change investigated frequency range from 2310MHz to 2415MHz and 2450MHz to 2500MHz.

8.5. Test result

PASS. (See below detailed test result)

TR-4-E-009 Radiated Emission Test Result

Test Site : DDT 3m Chamber	E:\2014 Report Data\hongjirui\RF.EM6
Test Date : 2014-08-31	Tested By : Leo
EUT : Turning	Model Number : RRAP-01
Power Supply : AC 120V/60Hz	Test Mode : Tx mode 11b CH1
Condition : Temp:24.5'C,Humi:55%, Press:100.1kPa	Antenna/Distance : 2013 HF907/3m/HORIZONTAL
Memo :	

Data: 3

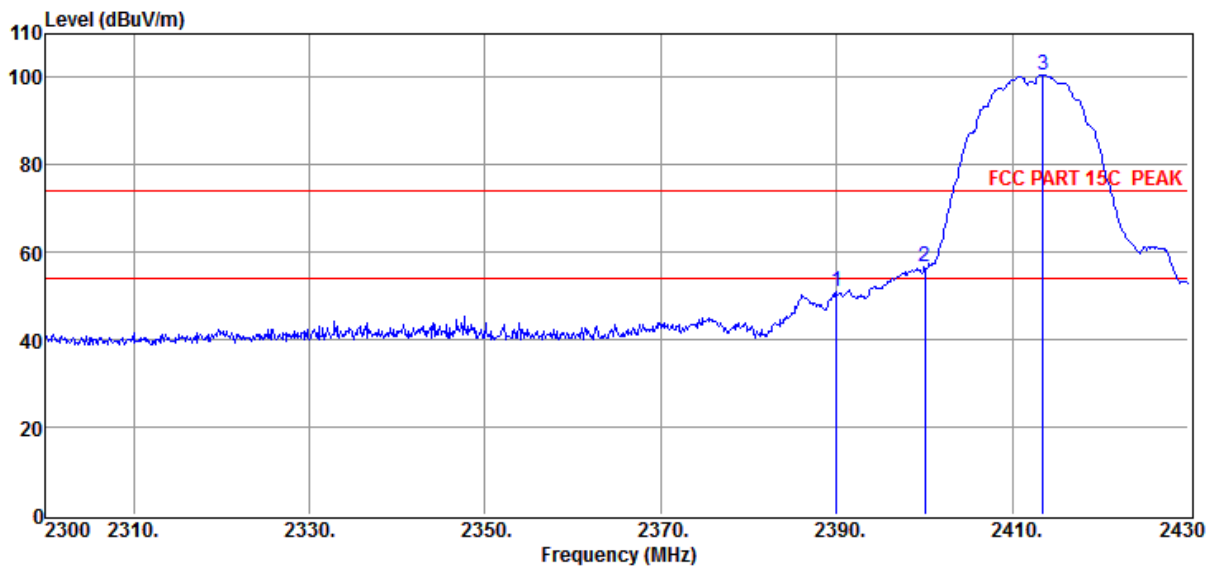

Item (Mark)	Freq (MHz)	Read Level (dBμV)	Antenna Factor (dB/m)	PRM Factor dB	Cable Loss dB	Result Level (dBμV/m)	Limit Line (dBμV/m)	Over Limit (dB)	Detector	Polarization
1	2390.00	56.27	29.99	43.48	8.35	51.13	74.00	-22.87	Peak	HORIZONTAL
2	2400.00	61.69	29.99	43.49	8.35	56.54	74.00	-17.46	Peak	HORIZONTAL
3	2413.49	105.79	30.04	43.49	8.35	100.69	74.00	26.69	Peak	HORIZONTAL

Note: 1. Result Level = Read Level + Antenna Factor + Cable loss - PRM Factor.
 2. If Peak Result complies with AV limit, AV Result is deemed to comply with AV limit.
 3. Test setup: RBW: 1 MHz, VBW: 3 MHz, Sweep time: auto.

TR-4-E-009 Radiated Emission Test Result

Test Site : DDT 3m Chamber	E:\2014 Report Data\hongjirui\RF.EM6
Test Date : 2014-08-31	Tested By : Leo
EUT : Turning	Model Number : RRAP-01
Power Supply : AC 120V/60Hz	Test Mode : Tx mode 11b CH1
Condition : Temp:24.5'C,Humi:55%, Press:100.1kPa	Antenna/Distance : 2013 HF907/3m/VERTICAL
Memo :	

Data: 4

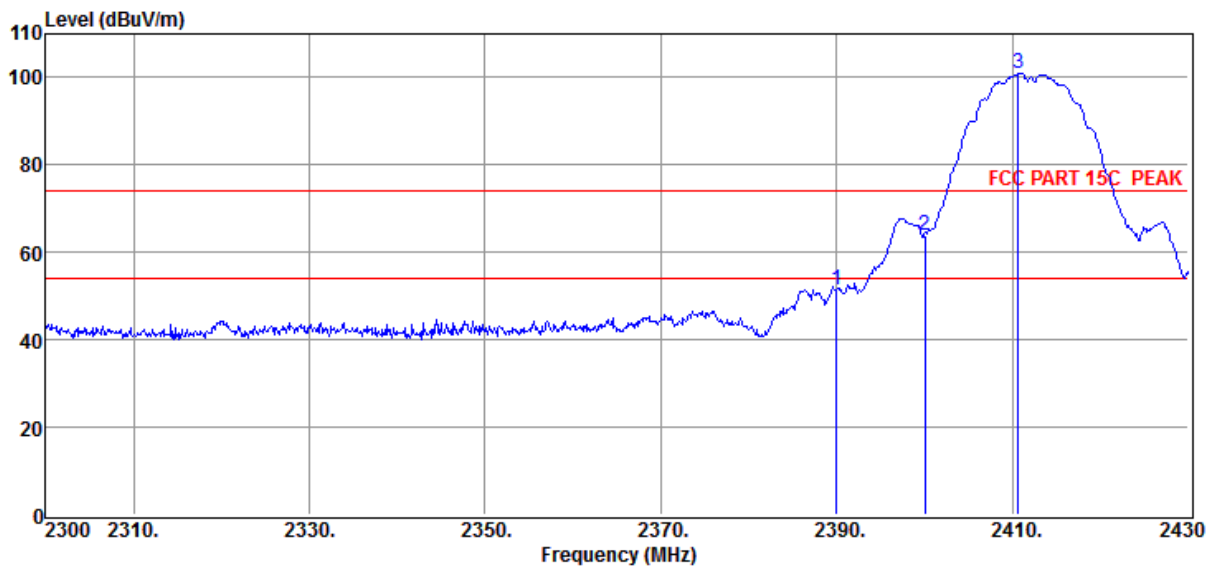

Item (Mark)	Freq (MHz)	Read Level (dBμV)	Antenna Factor (dB/m)	PRM Factor dB	Cable Loss dB	Result Level (dBμV/m)	Limit Line (dBμV/m)	Over Limit (dB)	Detector	Polarization
1	2390.00	56.40	29.99	43.48	8.35	51.26	74.00	-22.74	Peak	VERTICAL
2	2400.00	69.02	29.99	43.49	8.35	63.87	74.00	-10.13	Peak	VERTICAL
3	2410.63	106.18	30.04	43.49	8.35	101.08	74.00	27.08	Peak	VERTICAL

Note: 1. Result Level = Read Level + Antenna Factor + Cable loss - PRM Factor.
 2. If Peak Result complies with AV limit, AV Result is deemed to comply with AV limit.
 3. Test setup: RBW: 1 MHz, VBW: 3 MHz, Sweep time: auto.

TR-4-E-009 Radiated Emission Test Result

Test Site	: DDT 3m Chamber	E:\2014 Report Data\hongjirui\RF.EM6
Test Date	: 2014-08-31	Tested By : Leo
EUT	: Turning	Model Number : RRAP-01
Power Supply	: AC 120V/60Hz	Test Mode : Tx mode 11b CH11
Condition	: Temp:24.5'C,Humi:55%, Press:100.1kPa	Antenna/Distance : 2013 HF907/3m/VERTICAL
Memo	:	

Data: 9

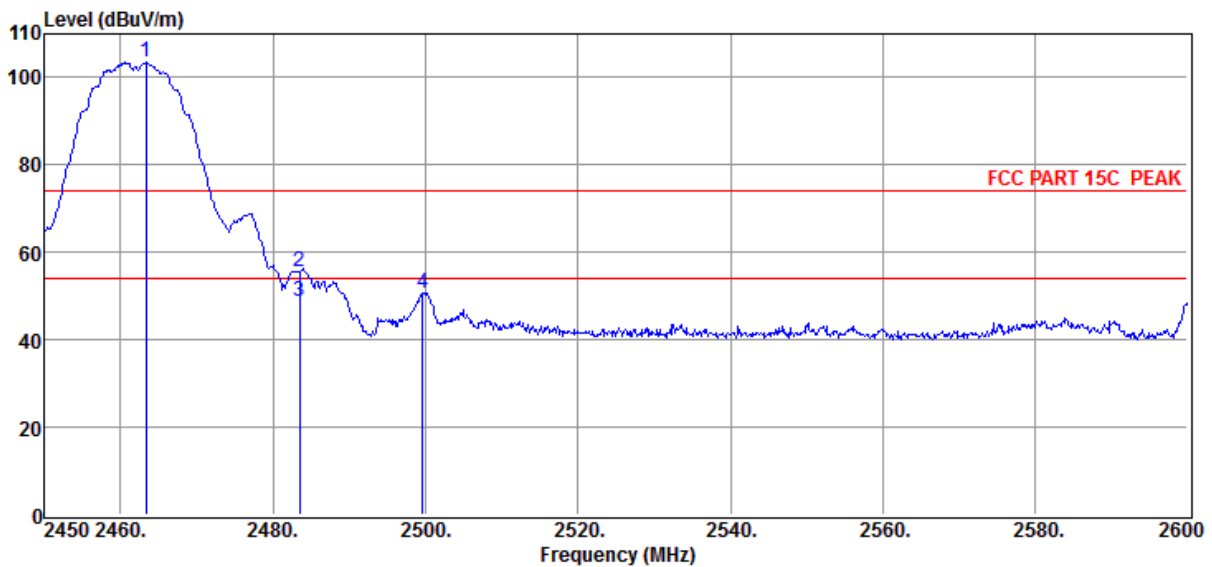

Item (Mark)	Freq (MHz)	Read Level (dBμV)	Antenna Factor (dB/m)	PRM Factor dB	Cable Loss dB	Result Level (dBμV/m)	Limit Line (dBμV/m)	Over Limit (dB)	Detector	Polarization
1	2463.35	108.28	30.20	43.49	8.45	103.44	74.00	29.44	Peak	VERTICAL
2	2483.45	60.39	30.25	43.50	8.50	55.64	74.00	-18.36	Peak	VERTICAL
3	2483.45	53.36	30.25	43.50	8.50	48.61	54.00	-5.39	Average	VERTICAL
4	2499.65	55.46	30.30	43.50	8.50	50.76	74.00	-23.24	Peak	VERTICAL

- Note: 1. Result Level = Read Level + Antenna Factor + Cable loss - PRM Factor.
 2. If Peak Result complies with AV limit, AV Result is deemed to comply with AV limit.
 3. Test setup: RBW: 1 MHz, VBW: 3 MHz, Sweep time: auto.

TR-4-E-009 Radiated Emission Test Result

Test Site	: DDT 3m Chamber	E:	\2014 Report Data\hongjirui\RF.EM6
Test Date	: 2014-08-31	Tested By	: Leo
EUT	: Turning	Model Number	: RRAP-01
Power Supply	: AC 120V/60Hz	Test Mode	: Tx mode 11b CH11
Condition	: Temp:24.5'C,Humi:55%, Press:100.1kPa	Antenna/Distance	: 2013 HF907/3m/HORIZONTAL
Memo	:		

Data: 10

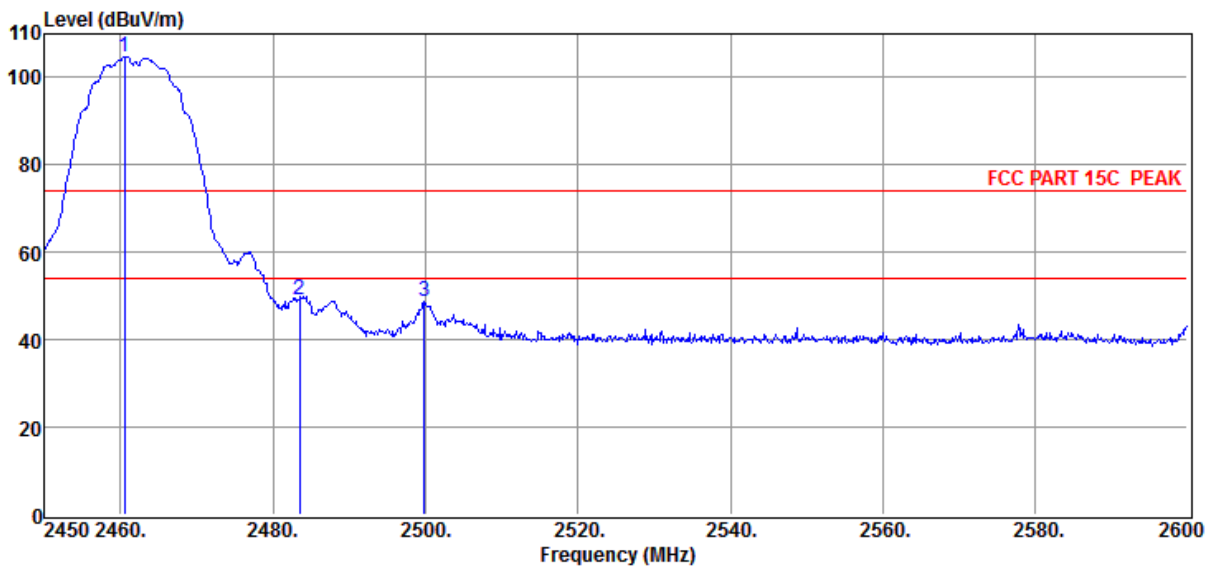

Item (Mark)	Freq (MHz)	Read Level (dBμV)	Antenna Factor (dB/m)	PRM Factor dB	Cable Loss dB	Result Level (dBμV/m)	Limit Line (dBμV/m)	Over Limit (dB)	Detector	Polarization
1	2460.50	109.55	30.20	43.49	8.45	104.71	74.00	30.71	Peak	HORIZONTAL
2	2483.45	53.88	30.25	43.50	8.50	49.13	74.00	-24.87	Peak	HORIZONTAL
3	2499.80	53.35	30.30	43.50	8.50	48.65	74.00	-25.35	Peak	HORIZONTAL

- Note: 1. Result Level = Read Level + Antenna Factor + Cable loss - PRM Factor.
 2. If Peak Result complies with AV limit, AV Result is deemed to comply with AV limit.
 3. Test setup: RBW: 1 MHz, VBW: 3 MHz, Sweep time: auto.

TR-4-E-009 Radiated Emission Test Result

Test Site : DDT 3m Chamber	E:\2014 Report Data\hongjirui\RF.EM6
Test Date : 2014-08-31	Tested By : Leo
EUT : Turning	Model Number : RRAP-01
Power Supply : AC 120V/60Hz	Test Mode : Tx mode 11g CH1
Condition : Temp:24.5'C,Humi:55%, Press:100.1kPa	Antenna/Distance : 2013 HF907/3m/VERTICAL
Memo :	

Data: 11

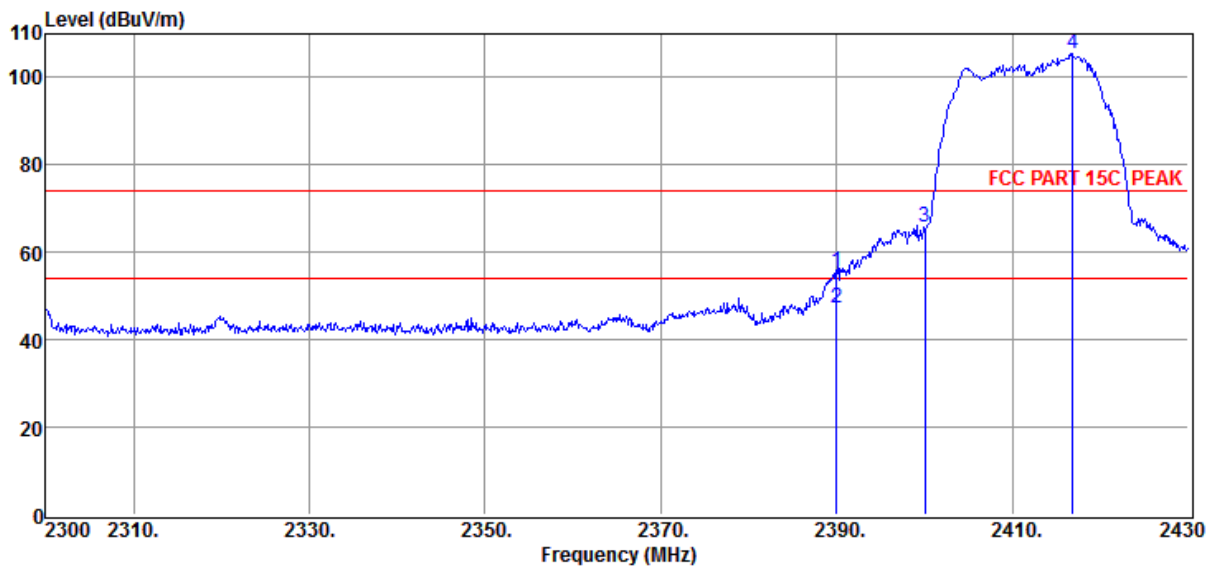

Item (Mark)	Freq (MHz)	Read Level (dBμV)	Antenna Factor (dB/m)	PRM Factor dB	Cable Loss dB	Result Level (dBμV/m)	Limit Line (dBμV/m)	Over Limit (dB)	Detector	Polarization
1	2390.00	60.89	29.99	43.48	8.35	55.75	74.00	-18.25	Peak	VERTICAL
2	2390.00	52.25	29.99	43.48	8.35	47.11	54.00	-6.89	Average	VERTICAL
3	2400.00	70.98	29.99	43.49	8.35	65.83	74.00	-8.17	Peak	VERTICAL
4	2416.87	110.52	30.04	43.49	8.40	105.47	74.00	31.47	Peak	VERTICAL

Note: 1. Result Level = Read Level + Antenna Factor + Cable loss - PRM Factor.
 2. If Peak Result complies with AV limit, AV Result is deemed to comply with AV limit.
 3. Test setup: RBW: 1 MHz, VBW: 3 MHz, Sweep time: auto.

TR-4-E-009 Radiated Emission Test Result

Test Site : DDT 3m Chamber	E:\2014 Report Data\hongjirui\RF.EM6
Test Date : 2014-08-31	Tested By : Leo
EUT : Turning	Model Number : RRAP-01
Power Supply : AC 120V/60Hz	Test Mode : Tx mode 11g CH1
Condition : Temp:24.5'C,Humi:55%, Press:100.1kPa	Antenna/Distance : 2013 HF907/3m/HORIZONTAL
Memo :	

Data: 12

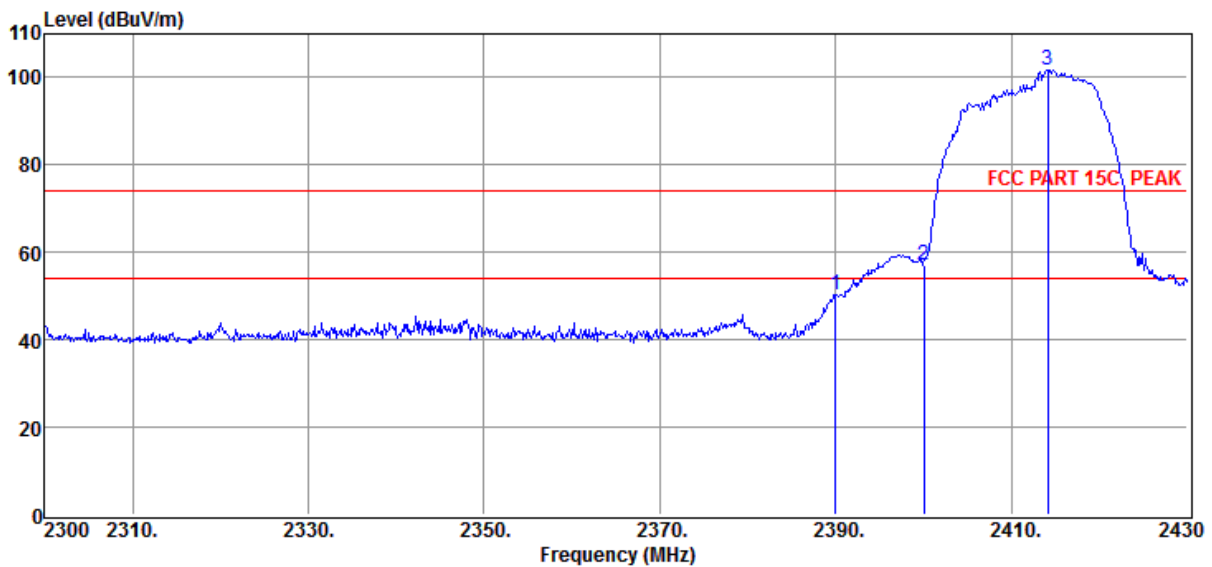

Item (Mark)	Freq (MHz)	Read Level (dBμV)	Antenna Factor (dB/m)	PRM Factor dB	Cable Loss dB	Result Level (dBμV/m)	Limit Line (dBμV/m)	Over Limit (dB)	Detector	Polarization
1	2390.00	55.51	29.99	43.48	8.35	50.37	74.00	-23.63	Peak	HORIZONTAL
2	2400.00	62.29	29.99	43.49	8.35	57.14	74.00	-16.86	Peak	HORIZONTAL
3	2414.14	106.94	30.04	43.49	8.35	101.84	74.00	27.84	Peak	HORIZONTAL

Note: 1. Result Level = Read Level + Antenna Factor + Cable loss - PRM Factor.
 2. If Peak Result complies with AV limit, AV Result is deemed to comply with AV limit.
 3. Test setup: RBW: 1 MHz, VBW: 3 MHz, Sweep time: auto.

TR-4-E-009 Radiated Emission Test Result

Test Site : DDT 3m Chamber	E:\2014 Report Data\hongjirui\RF.EM6
Test Date : 2014-08-31	Tested By : Leo
EUT : Turning	Model Number : RRAP-01
Power Supply : AC 120V/60Hz	Test Mode : Tx mode 11g CH11
Condition : Temp:24.5'C,Humi:55%, Press:100.1kPa	Antenna/Distance : 2013 HF907/3m/VERTICAL
Memo :	

Data: 19

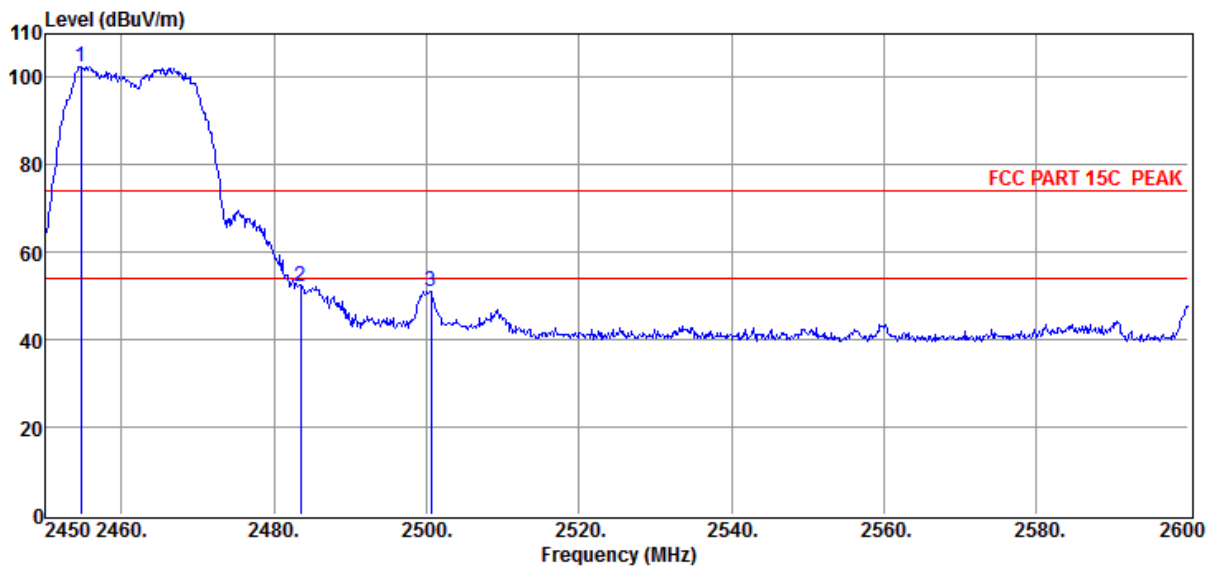

Item (Mark)	Freq (MHz)	Read Level (dBμV)	Antenna Factor (dB/m)	PRM Factor dB	Cable Loss dB	Result Level (dBμV/m)	Limit Line (dBμV/m)	Over Limit (dB)	Detector	Polarization
1	2454.65	107.39	30.20	43.49	8.45	102.55	74.00	28.55	Peak	VERTICAL
2	2483.50	57.00	30.25	43.50	8.50	52.25	74.00	-21.75	Peak	VERTICAL
3	2500.55	55.65	30.30	43.50	8.50	50.95	74.00	-23.05	Peak	VERTICAL

Note: 1. Result Level = Read Level + Antenna Factor + Cable loss - PRM Factor.
 2. If Peak Result complies with AV limit, AV Result is deemed to comply with AV limit.
 3. Test setup: RBW: 1 MHz, VBW: 3 MHz, Sweep time: auto.

TR-4-E-009 Radiated Emission Test Result

Test Site	: DDT 3m Chamber	E:\2014 Report Data\hongjirui\RF.EM6
Test Date	: 2014-08-31	Tested By : Leo
EUT	: Turning	Model Number : RRAP-01
Power Supply	: AC 120V/60Hz	Test Mode : Tx mode 11g CH11
Condition	: Temp:24.5'C,Humi:55%, Press:100.1kPa	Antenna/Distance : 2013 HF907/3m/HORIZONTAL
Memo	:	

Data: 20

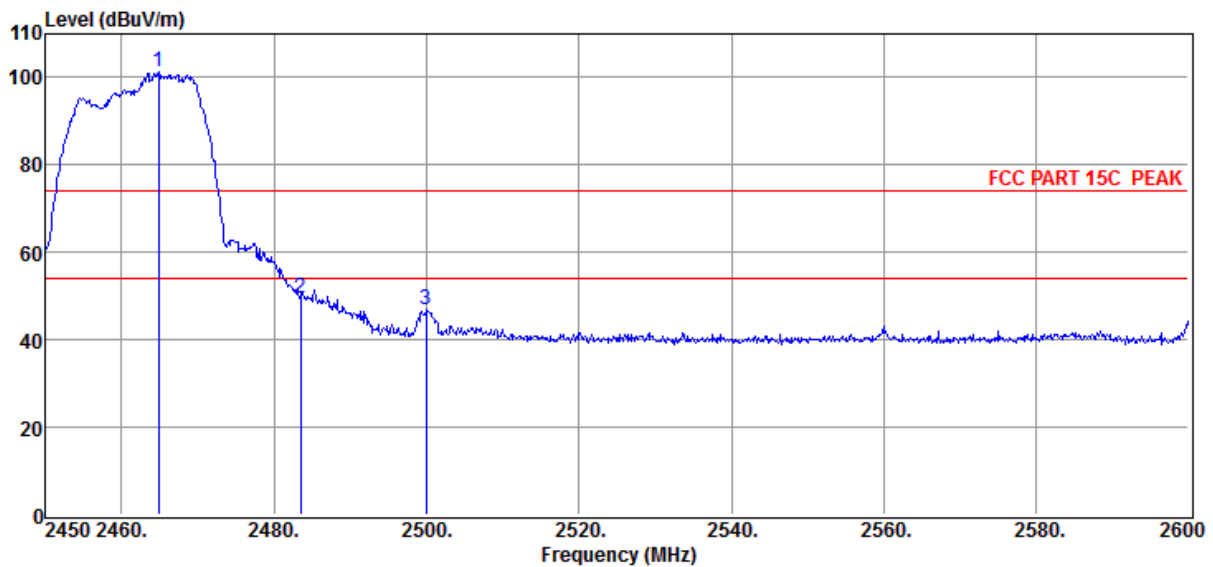

Item (Mark)	Freq (MHz)	Read Level (dBμV)	Antenna Factor (dB/m)	PRM Factor dB	Cable Loss dB	Result Level (dBμV/m)	Limit Line (dBμV/m)	Over Limit (dB)	Detector	Polarization
1	2464.85	106.10	30.20	43.49	8.45	101.26	74.00	27.26	Peak	HORIZONTAL
2	2483.50	54.41	30.25	43.50	8.50	49.66	74.00	-24.34	Peak	HORIZONTAL
3	2499.95	51.49	30.30	43.50	8.50	46.79	74.00	-27.21	Peak	HORIZONTAL

- Note: 1. Result Level = Read Level + Antenna Factor + Cable loss - PRM Factor.
 2. If Peak Result complies with AV limit, AV Result is deemed to comply with AV limit.
 3. Test setup: RBW: 1 MHz, VBW: 3 MHz, Sweep time: auto.

TR-4-E-009 Radiated Emission Test Result

Test Site : DDT 3m Chamber	E:\2014 Report Data\hongjirui\RF.EM6
Test Date : 2014-08-31	Tested By : Leo
EUT : Turning	Model Number : RRAP-01
Power Supply : AC 120V/60Hz	Test Mode : Tx mode 11n HT20 CH1
Condition : Temp:24.5'C,Humi:55%, Press:100.1kPa	Antenna/Distance : 2013 HF907/3m/HORIZONTAL
Memo :	

Data: 21

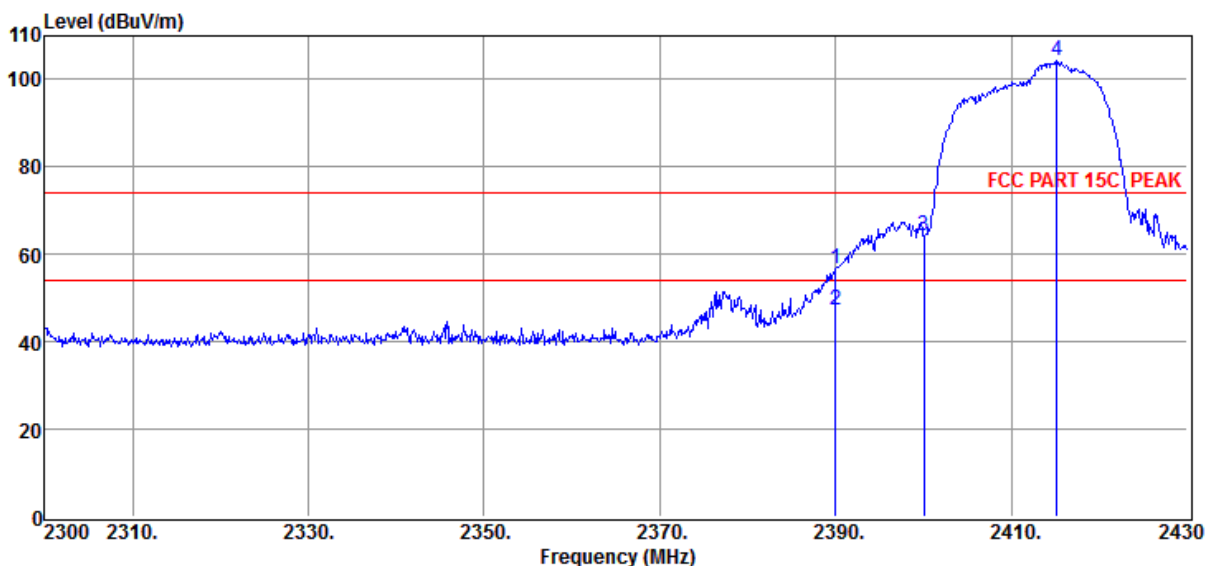

Item (Mark)	Freq (MHz)	Read Level (dBμV)	Antenna Factor (dB/m)	PRM Factor dB	Cable Loss dB	Result Level (dBμV/m)	Limit Line (dBμV/m)	Over Limit (dB)	Detector	Polarization
1	2390.00	61.79	29.99	43.48	8.35	56.65	74.00	-17.35	Peak	HORIZONTAL
2	2390.00	52.32	29.99	43.48	8.35	47.18	54.00	-6.82	Average	HORIZONTAL
3	2400.00	69.26	29.99	43.49	8.35	64.11	74.00	-9.89	Peak	HORIZONTAL
4	2415.18	109.38	30.04	43.49	8.35	104.28	74.00	30.28	Peak	HORIZONTAL

Note: 1. Result Level = Read Level + Antenna Factor + Cable loss - PRM Factor.
 2. If Peak Result complies with AV limit, AV Result is deemed to comply with AV limit.
 3. Test setup: RBW: 1 MHz, VBW: 3 MHz, Sweep time: auto.

TR-4-E-009 Radiated Emission Test Result

Test Site : DDT 3m Chamber	E:\2014 Report Data\hongjirui\RF.EM6
Test Date : 2014-08-31	Tested By : Leo
EUT : Turning	Model Number : RRAP-01
Power Supply : AC 120V/60Hz	Test Mode : Tx mode 11n HT20 CH1
Condition : Temp:24.5'C,Humi:55%, Press:100.1kPa	Antenna/Distance : 2013 HF907/3m/VERTICAL
Memo :	

Data: 22

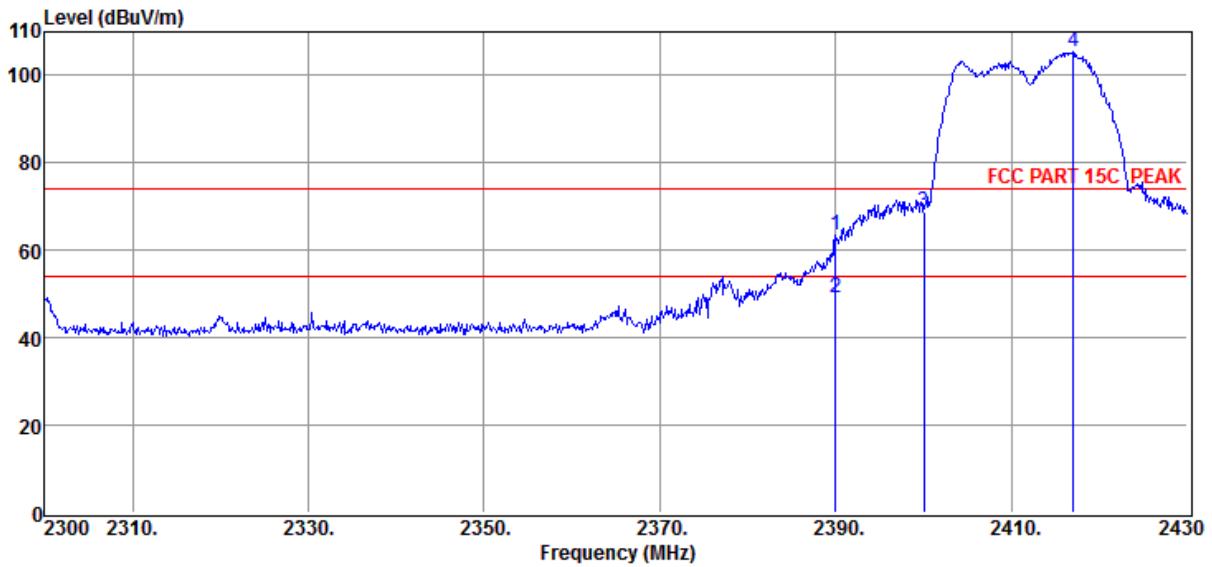

Item (Mark)	Freq (MHz)	Read Level (dBμV)	Antenna Factor (dB/m)	PRM Factor dB	Cable Loss dB	Result Level (dBμV/m)	Limit Line (dBμV/m)	Over Limit (dB)	Detector	Polarization
1	2390.00	68.74	29.99	43.48	8.35	63.60	74.00	-10.40	Peak	VERTICAL
2	2390.00	54.32	29.99	43.48	8.35	49.18	54.00	-4.82	Average	VERTICAL
3	2400.00	74.11	29.99	43.49	8.35	68.96	74.00	-5.04	Peak	VERTICAL
4	2417.00	110.40	30.04	43.49	8.40	105.35	74.00	31.35	Peak	VERTICAL

- Note: 1. Result Level = Read Level + Antenna Factor + Cable loss - PRM Factor.
 2. If Peak Result complies with AV limit, AV Result is deemed to comply with AV limit.
 3. Test setup: RBW: 1 MHz, VBW: 3 MHz, Sweep time: auto.

TR-4-E-009 Radiated Emission Test Result

Test Site : DDT 3m Chamber	E:\2014 Report Data\hongjirui\RF.EM6
Test Date : 2014-08-31	Tested By : Leo
EUT : Turning	Model Number : RRAP-01
Power Supply : AC 120V/60Hz	Test Mode : Tx mode 11n HT20 CH11
Condition : Temp:24.5'C,Humi:55%, Press:100.1kPa	Antenna/Distance : 2013 HF907/3m/HORIZONTAL
Memo :	

Data: 29

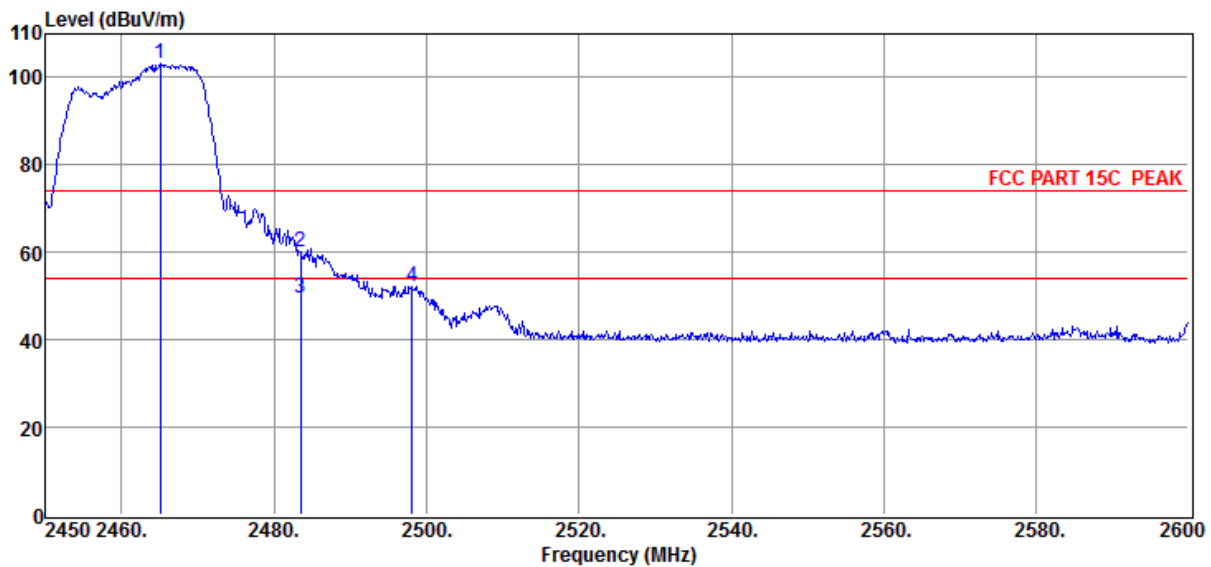

Item (Mark)	Freq (MHz)	Read Level (dBμV)	Antenna Factor (dB/m)	PRM Factor dB	Cable Loss dB	Result Level (dBμV/m)	Limit Line (dBμV/m)	Over Limit (dB)	Detector	Polarization
1	2465.00	108.15	30.20	43.49	8.45	103.31	74.00	29.31	Peak	HORIZONTAL
2	2483.50	64.71	30.25	43.50	8.50	59.96	74.00	-14.04	Peak	HORIZONTAL
3	2483.50	54.36	30.25	43.50	8.50	49.61	54.00	-4.39	Average	HORIZONTAL
4	2498.15	56.96	30.30	43.50	8.50	52.26	74.00	-21.74	Peak	HORIZONTAL

Note: 1. Result Level = Read Level + Antenna Factor + Cable loss - PRM Factor.
 2. If Peak Result complies with AV limit, AV Result is deemed to comply with AV limit.
 3. Test setup: RBW: 1 MHz, VBW: 3 MHz, Sweep time: auto.

TR-4-E-009 Radiated Emission Test Result

Test Site : DDT 3m Chamber	E:\2014 Report Data\hongjirui\RF.EM6
Test Date : 2014-08-31	Tested By : Leo
EUT : Turning	Model Number : RRAP-01
Power Supply : AC 120V/60Hz	Test Mode : Tx mode 11n HT20 CH11
Condition : Temp:24.5'C,Humi:55%, Press:100.1kPa	Antenna/Distance : 2013 HF907/3m/VERTICAL
Memo :	

Data: 30

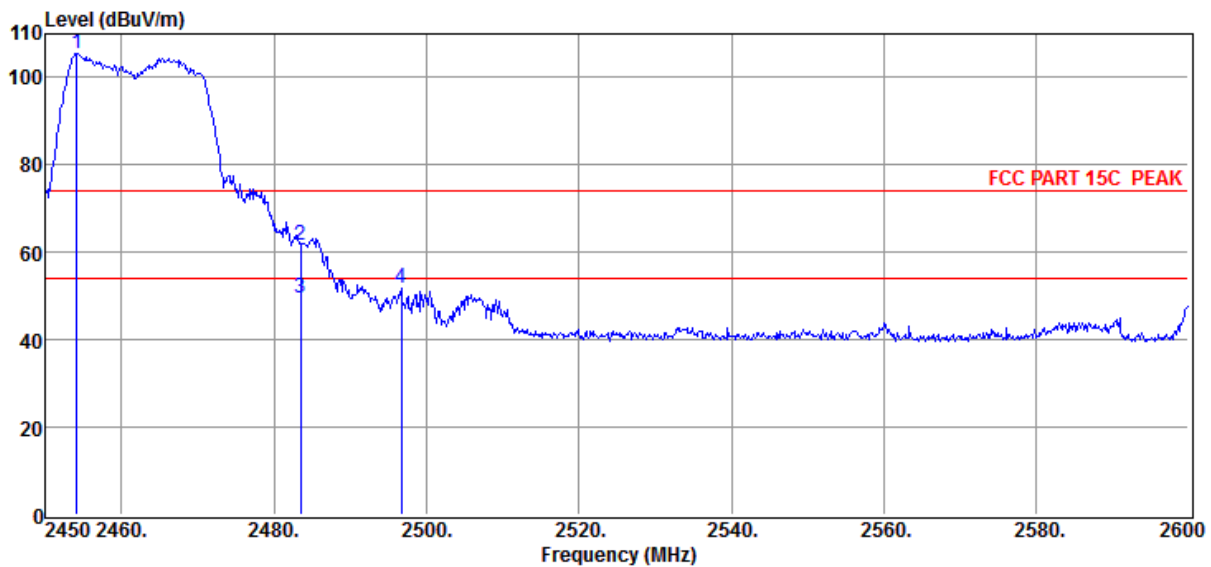

Item (Mark)	Freq (MHz)	Read Level (dBμV)	Antenna Factor (dB/m)	PRM Factor dB	Cable Loss dB	Result Level (dBμV/m)	Limit Line (dBμV/m)	Over Limit (dB)	Detector	Polarization
1	2454.05	110.38	30.20	43.49	8.45	105.54	74.00	31.54	Peak	VERTICAL
2	2483.50	66.36	30.25	43.50	8.50	61.61	74.00	-12.39	Peak	VERTICAL
3	2483.50	54.21	30.25	43.50	8.50	49.46	54.00	-4.54	Average	VERTICAL
4	2496.65	56.65	30.30	43.50	8.50	51.95	74.00	-22.05	Peak	VERTICAL

Note: 1. Result Level = Read Level + Antenna Factor + Cable loss - PRM Factor.
 2. If Peak Result complies with AV limit, AV Result is deemed to comply with AV limit.
 3. Test setup: RBW: 1 MHz, VBW: 3 MHz, Sweep time: auto.

TR-4-E-009 Radiated Emission Test Result

Test Site : DDT 3m Chamber	E:\2014 Report Data\hongjirui\RF.EM6
Test Date : 2014-08-31	Tested By : Leo
EUT : Turning	Model Number : RRAP-01
Power Supply : AC 120V/60Hz	Test Mode : Tx mode 11n HT40 CH3
Condition : Temp:24.5'C,Humi:55%, Press:100.1kPa	Antenna/Distance : 2013 HF907/3m/VERTICAL
Memo :	

Data: 31

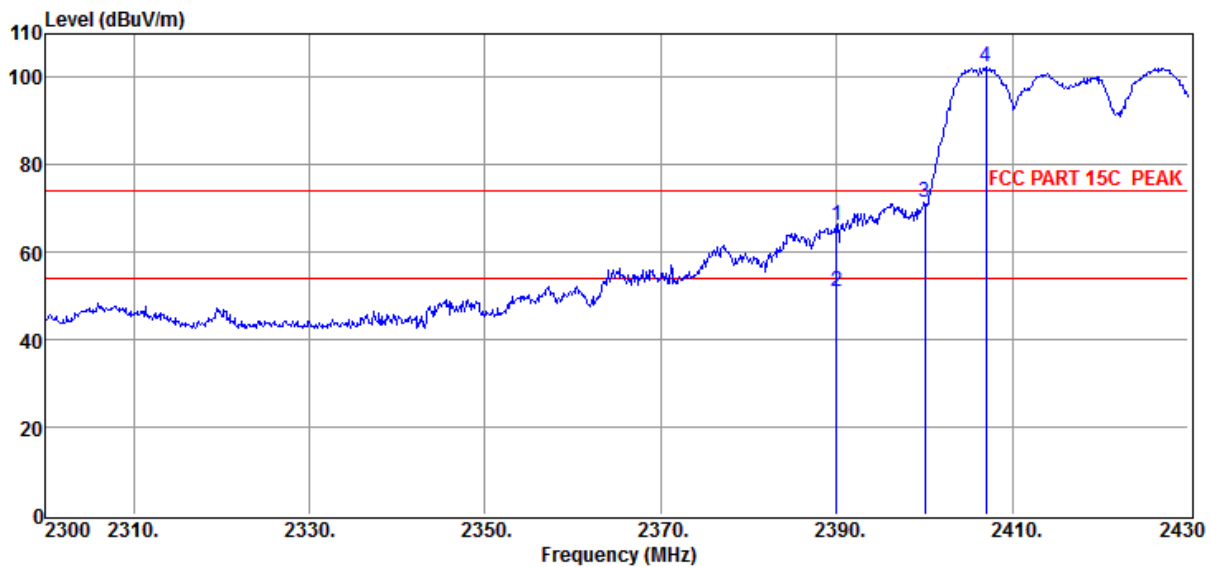

Item (Mark)	Freq (MHz)	Read Level (dBμV)	Antenna Factor (dB/m)	PRM Factor dB	Cable Loss dB	Result Level (dBμV/m)	Limit Line (dBμV/m)	Over Limit (dB)	Detector	Polarization
1	2390.00	71.46	29.99	43.48	8.35	66.32	74.00	-7.68	Peak	VERTICAL
2	2390.00	56.12	29.99	43.48	8.35	50.98	54.00	-3.02	Average	VERTICAL
3	2400.00	76.52	29.99	43.49	8.35	71.37	74.00	-2.63	Peak	VERTICAL
4	2406.99	107.41	30.04	43.49	8.35	102.31	74.00	28.31	Peak	VERTICAL

Note: 1. Result Level = Read Level + Antenna Factor + Cable loss - PRM Factor.
 2. If Peak Result complies with AV limit, AV Result is deemed to comply with AV limit.
 3. Test setup: RBW: 1 MHz, VBW: 3 MHz, Sweep time: auto.

TR-4-E-009 Radiated Emission Test Result

Test Site : DDT 3m Chamber	E:\2014 Report Data\hongjirui\RF.EM6
Test Date : 2014-08-31	Tested By : Leo
EUT : Turning	Model Number : RRAP-01
Power Supply : AC 120V/60Hz	Test Mode : Tx mode 11n HT40 CH3
Condition : Temp:24.5'C,Humi:55%, Press:100.1kPa	Antenna/Distance : 2013 HF907/3m/HORIZONTAL
Memo :	

Data: 32

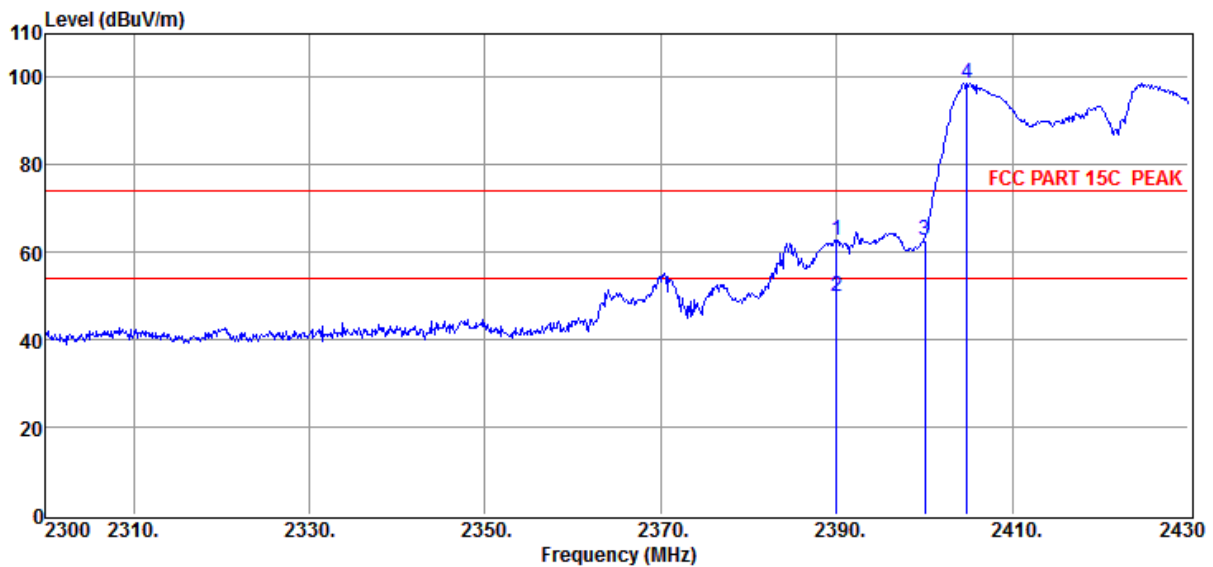

Item (Mark)	Freq (MHz)	Read Level (dBμV)	Antenna Factor (dB/m)	PRM Factor dB	Cable Loss dB	Result Level (dBμV/m)	Limit Line (dBμV/m)	Over Limit (dB)	Detector	Polarization
1	2390.00	67.86	29.99	43.48	8.35	62.72	74.00	-11.28	Peak	HORIZONTAL
2	2390.00	55.21	29.99	43.48	8.35	50.07	54.00	-3.93	Average	HORIZONTAL
3	2400.00	67.92	29.99	43.49	8.35	62.77	74.00	-11.23	Peak	HORIZONTAL
4	2404.78	103.72	30.04	43.49	8.35	98.62	74.00	24.62	Peak	HORIZONTAL

Note: 1. Result Level = Read Level + Antenna Factor + Cable loss - PRM Factor.
 2. If Peak Result complies with AV limit, AV Result is deemed to comply with AV limit.
 3. Test setup: RBW: 1 MHz, VBW: 3 MHz, Sweep time: auto.

TR-4-E-009 Radiated Emission Test Result

Test Site : DDT 3m Chamber	E:\2014 Report Data\hongjirui\RF.EM6
Test Date : 2014-08-31	Tested By : Leo
EUT : Turning	Model Number : RRAP-01
Power Supply : AC 120V/60Hz	Test Mode : Tx mode 11n HT40 CH9
Condition : Temp:24.5'C,Humi:55%, Press:100.1kPa	Antenna/Distance : 2013 HF907/3m/VERTICAL
Memo :	

Data: 39

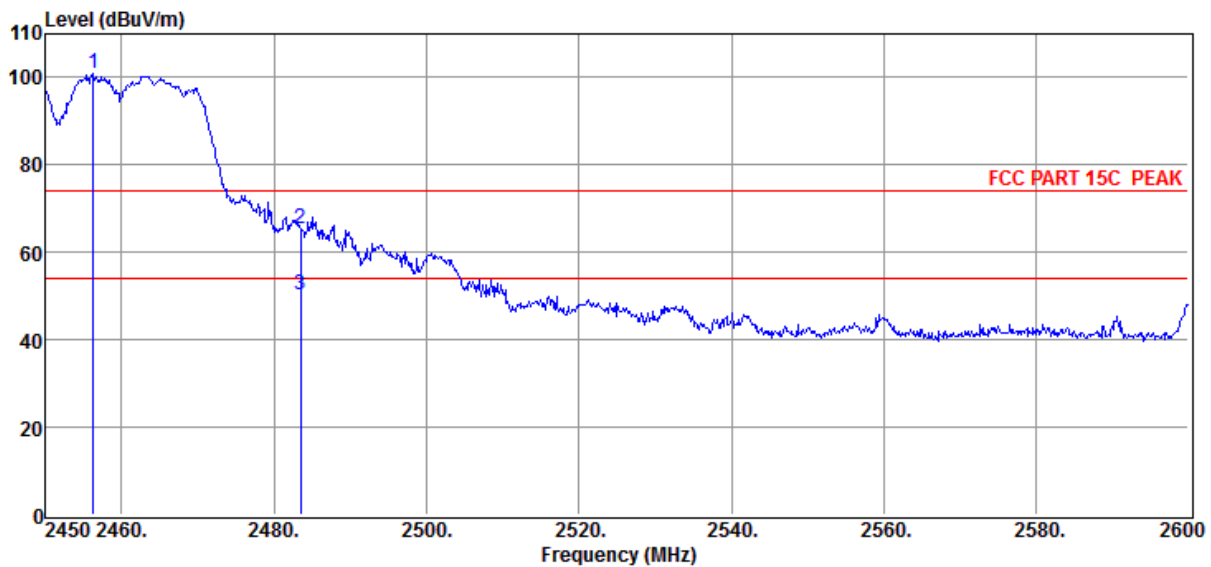

Item (Mark)	Freq (MHz)	Read Level (dBμV)	Antenna Factor (dB/m)	PRM Factor dB	Cable Loss dB	Result Level (dBμV/m)	Limit Line (dBμV/m)	Over Limit (dB)	Detector	Polarization
1	2456.30	105.70	30.20	43.49	8.45	100.86	74.00	26.86	Peak	VERTICAL
2	2483.50	69.98	30.25	43.50	8.50	65.23	74.00	-8.77	Peak	VERTICAL
3	2483.50	55.12	30.25	43.50	8.50	50.37	54.00	-3.63	Average	VERTICAL

Note: 1. Result Level = Read Level + Antenna Factor + Cable loss - PRM Factor.
 2. If Peak Result complies with AV limit, AV Result is deemed to comply with AV limit.
 3. Test setup: RBW: 1 MHz, VBW: 3 MHz, Sweep time: auto.

TR-4-E-009 Radiated Emission Test Result

Test Site	: DDT 3m Chamber	E:	E:\2014 Report Data\hongjirui\RF.EM6
Test Date	: 2014-08-31	Tested By	: Leo
EUT	: Turning	Model Number	: RRAP-01
Power Supply	: AC 120V/60Hz	Test Mode	: Tx mode 11n HT40 CH9
Condition	: Temp:24.5'C,Humi:55%, Press:100.1kPa	Antenna/Distance	: 2013 HF907/3m/HORIZONTAL
Memo	:		

Data: 40

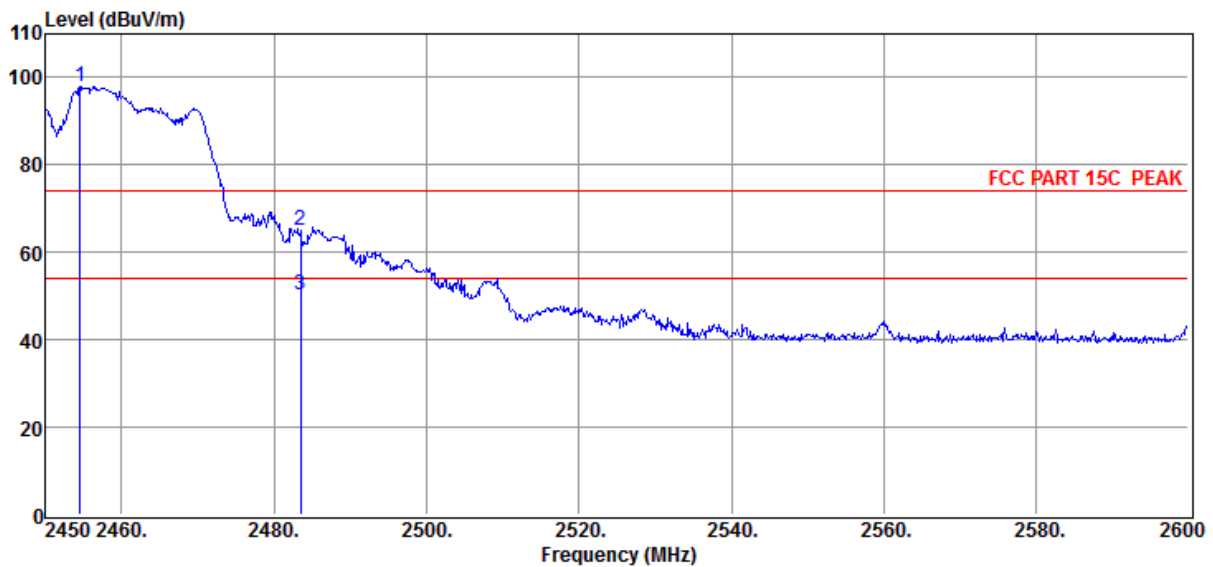

Item (Mark)	Freq (MHz)	Read Level (dBμV)	Antenna Factor (dB/m)	PRM Factor dB	Cable Loss dB	Result Level (dBμV/m)	Limit Line (dBμV/m)	Over Limit (dB)	Detector	Polarization
1	2454.50	102.83	30.20	43.49	8.45	97.99	74.00	23.99	Peak	HORIZONTAL
2	2483.50	69.72	30.25	43.50	8.50	64.97	74.00	-9.03	Peak	HORIZONTAL
3	2483.50	54.89	30.25	43.50	8.50	50.14	54.00	-3.86	Average	HORIZONTAL

Note: 1. Result Level = Read Level + Antenna Factor + Cable loss - PRM Factor.
 2. If Peak Result complies with AV limit, AV Result is deemed to comply with AV limit.
 3. Test setup: RBW: 1 MHz, VBW: 3 MHz, Sweep time: auto.

9. Power Line Conducted Emission

9.1. Test equipment

Item	Equipment	Manufacturer	Model No.	Serial No.	Last Cal.	Cal. Interval
1	Test Receiver	R&S	ESU8	100316	2013/11/13	1 Year
2	LISN 1	R&S	ENV216	101109	2013/11/13	1 Year
3	LISN 2	R&S	ESH2-Z5	100309	2013/11/13	1 Year
4	Pulse Limiter	R&S	ESH3-Z2	101242	2013/11/13	1 Year

9.2. Block diagram of test setup

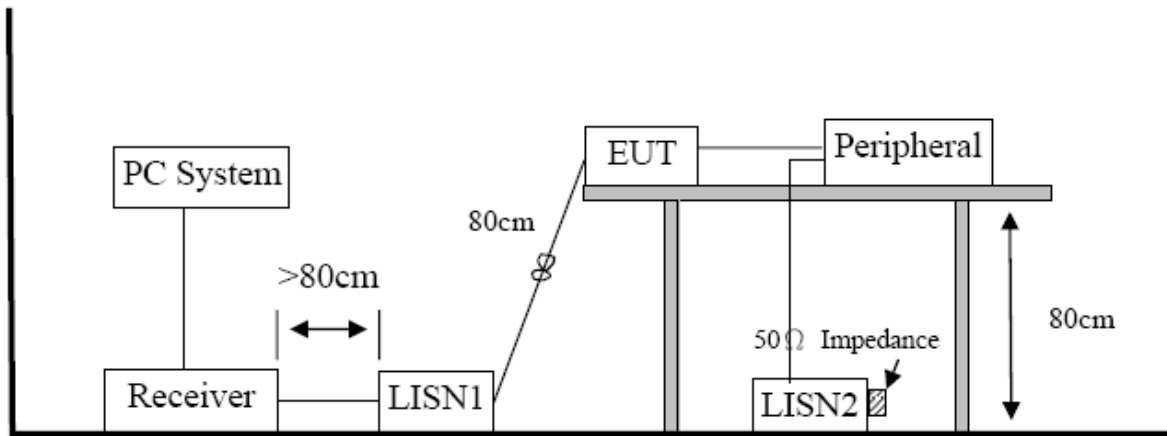

9.3. Power Line Conducted Emission Limits(Class B)

Frequency	Quasi-Peak Level dB(μ V)	Average Level dB(μ V)
150kHz ~ 500kHz	66 ~ 56*	56 ~ 46*
500kHz ~ 5MHz	56	46
5MHz ~ 30MHz	60	50

Note 1: * Decreasing linearly with logarithm of frequency.

Note 2: The lower limit shall apply at the transition frequencies.

9.4. Test Procedure

The EUT and Support equipment, if needed, were put placed on a non-metallic table, 80cm above the ground plane.

Configuration EUT to simulate typical usage as described in clause 2.4 and test equipment as described in clause 10.2 of this report.

All I/O cables were positioned to simulate typical actual usage as per ANSI C63.4.

All support equipment power received from a second LISN.

Emissions were measured on each current carrying line of the EUT using an EMI Test Receiver connected to the LISN powering the EUT.

The Receiver scanned from 150 kHz to 30MHz for emissions in each of the test modes.

During the above scans, the emissions were maximized by cable manipulation.

The test mode(s) described in clause 2.4 were scanned during the preliminary test.

After the preliminary scan, we found the test mode producing the highest emission level.

The EUT configuration and worse cable configuration of the above highest emission levels were recorded for reference of the final test.

EUT and support equipment were set up on the test bench as per the configuration with highest emission level in the preliminary test.

A scan was taken on both power lines, Neutral and Line, recording at least the six highest emissions.

Emission frequency and amplitude were recorded into a computer in which correction factors were used to calculate the emission level and compare reading to the applicable limit.

The test data of the worst-case condition(s) was recorded.

The bandwidth of test receiver is set at 9 KHz.

9.5. Test Result

PASS. (See below detailed test result)

Note1: All emissions not reported below are too low against the prescribed limits.

Note2: “----” means peak detection; “-----” mans average detection

TR-4-E-010 Conducted Emission Test Result

Test Site : DDT 1# Shield Room E:\2014 report data\hongjirui\CE.EM6
Test Date : 2014-08-31 **Tested By** : Leo
EUT : Turning **Model Number** : RRAP-01
Power Supply : AC 120V/60Hz **Test Mode** : Tx mode
Condition : Temp:24.5°C,Humi:55%,
LISN : 2013 ENV216/LINE
 Press:100.1kPa
Memo :

Data: 2

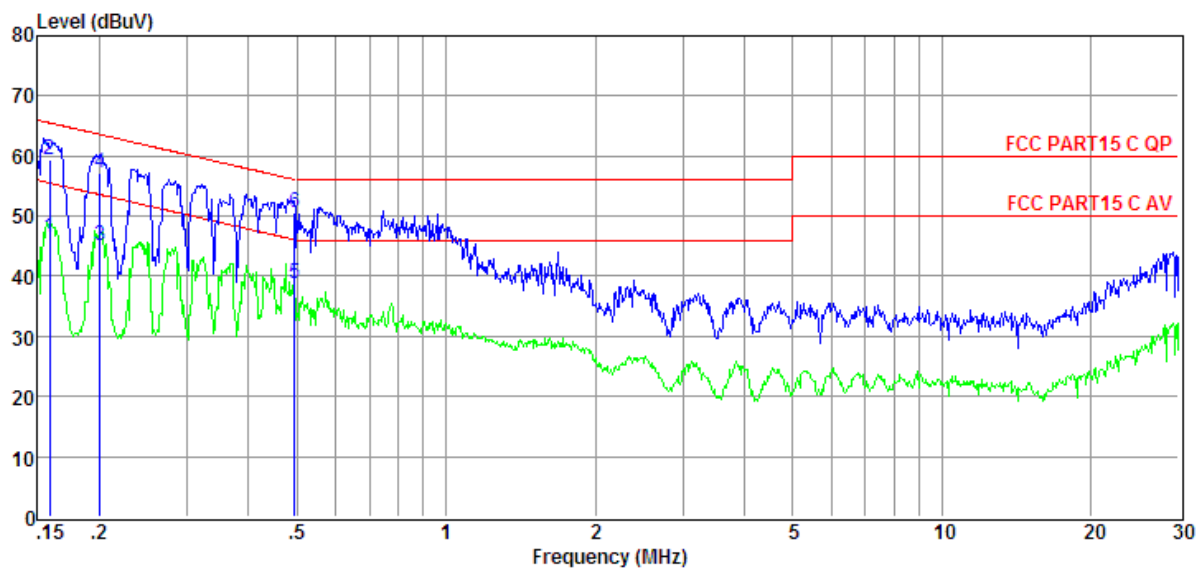

Item	Freq	Read Level	LISN Factor	Cable Loss	Pulse Limiter Factor	Result Level	Limit Line	Over Limit	Detector	Phase
(Mark)	(MHz)	(dBμV)	(dB)	(dB)	(dB)	(dBμV)	(dBμV)	(dB)		
1	0.16	26.98	9.61	0.01	9.84	46.44	55.52	-9.08	Average	LINE
2	0.16	39.98	9.61	0.01	9.84	59.44	65.52	-6.08	QP	LINE
3	0.20	25.69	9.62	0.02	9.85	45.18	53.58	-8.40	Average	LINE
4	0.20	37.69	9.62	0.02	9.85	57.18	63.58	-6.40	QP	LINE
5	0.49	19.30	9.63	0.03	9.87	38.83	46.10	-7.27	Average	LINE
6	0.49	31.08	9.63	0.03	9.87	50.61	56.10	-5.49	QP	LINE

Note: 1. Result Level = Read Level + LISN Factor + Pulse Limiter Factor + Cable loss.
 2. If QP Result complies with AV limit, AV Result is deemed to comply with AV limit.
 3. Test setup: RBW: 200 Hz (9 kHz—150 kHz), 9 kHz (150 kHz—30 MHz), Step size: 4 kHz, Scan time: auto.

TR-4-E-010 Conducted Emission Test Result

Test Site	: DDT 1# Shield Room	E:\2014 report data\hongjirui\CE.EM6
Test Date	: 2014-08-31	Tested By : Leo
EUT	: Turning	Model Number : RRAP-01
Power Supply	: AC 120V/60Hz	Test Mode : Tx mode
Condition	: Temp:24.5°C,Humi:55%, Press:100.1kPa	LISN : 2013 ENV216/NEUTRAL
Memo	:	

Data: 4

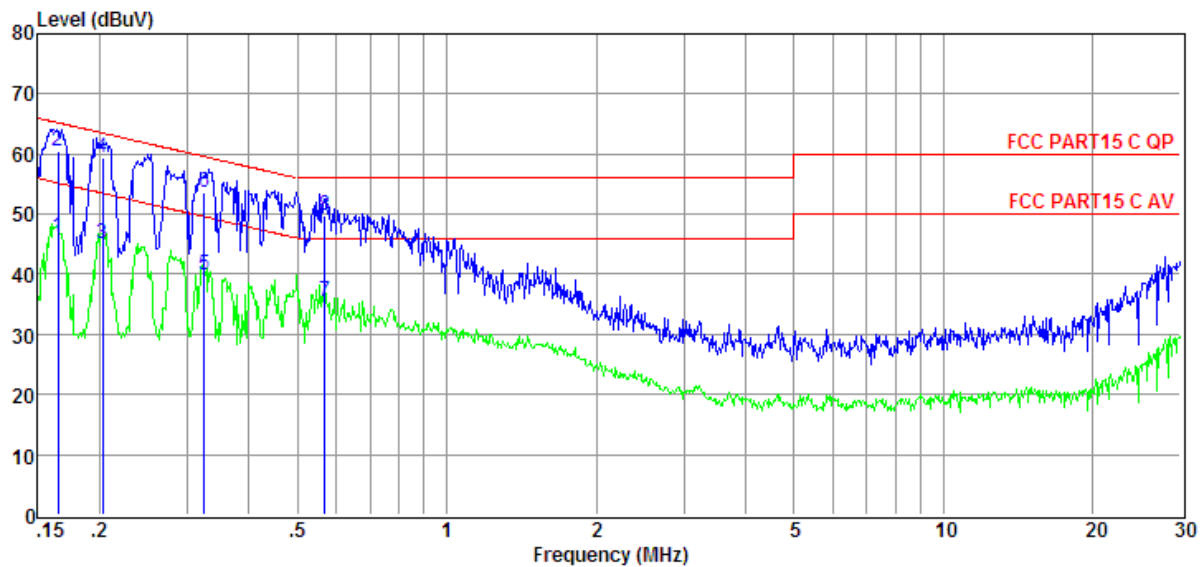

Item	Freq	Read Level	LISN Factor	Cable Loss	Pulse Limiter Factor	Result Level	Limit Line	Over Limit	Detector	Phase
(Mark)	(MHz)	(dBμV)	(dB)	(dB)	(dB)	(dBμV)	(dBμV)	(dB)		
1	0.17	26.78	9.60	0.01	9.84	46.23	55.21	-8.98	Average	NEUTRAL
2	0.17	41.14	9.60	0.01	9.84	60.59	65.21	-4.62	QP	NEUTRAL
3	0.20	25.52	9.59	0.02	9.85	44.98	53.49	-8.51	Average	NEUTRAL
4	0.20	39.84	9.59	0.02	9.85	59.30	63.49	-4.19	QP	NEUTRAL
5	0.33	20.44	9.60	0.02	9.85	39.91	49.57	-9.66	Average	NEUTRAL
6	0.33	34.15	9.60	0.02	9.85	53.62	59.57	-5.95	QP	NEUTRAL
7	0.57	15.89	9.61	0.04	9.86	35.40	46.00	-10.60	Average	NEUTRAL
8	0.57	30.17	9.61	0.04	9.86	49.68	56.00	-6.32	QP	NEUTRAL

Note: 1. Result Level = Read Level + LISN Factor + Pulse Limiter Factor + Cable loss.
 2. If QP Result complies with AV limit, AV Result is deemed to comply with AV limit.
 3. Test setup: RBW: 200 Hz (9 kHz—150 kHz), 9 kHz (150 kHz—30 MHz), Step size: 4 kHz, Scan time: auto.

10. Antenna Requirements

10.1. Limit

For intentional device, according to FCC 47 CFR Section 15.203 and RSS-Gen Issue 3 section 7.1.2 an intentional radiator shall be designed to ensure that no antenna other than that furnished by the responsible party shall be used with the device. And according to FCC 47 CFR Section 15.247 (b), if transmitting antennas of directional gain greater than 6dBi are used, the power shall be reduced by the amount in dB that the directional gain of the antenna exceeds 6dBi.

10.2. Result

The antennas used for this product are MIMO 4X4 built-in undetachable Patch antenna and that no antenna other than that furnished by the responsible party shall be used with the device, the maximum peak gain of the transmit antenna is only 2.7dBi.