

Portable Thermal Printer
SM-L200 SERIES

PRODUCT SPECIFICATIONS

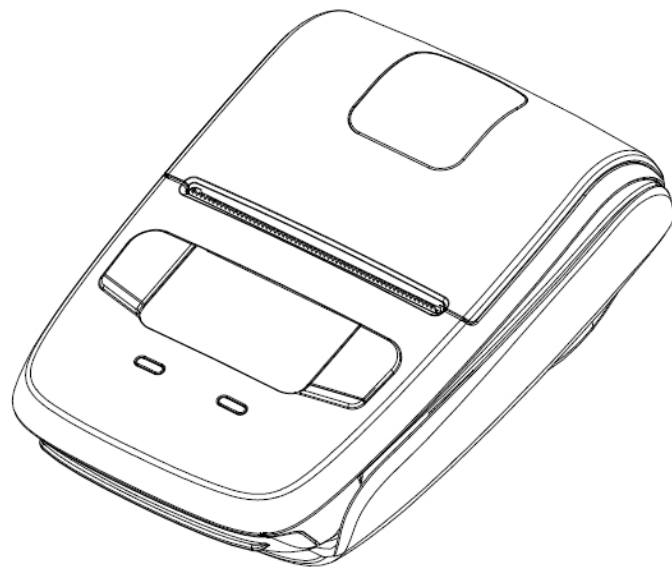

stair 

Radio Equipment Information:

Informations relatives à l'équipement radioélectrique :

Radiogeräteinformationen:

Informatie over de radioapparatuur:

Informazioni sulle apparecchiature radio:

Información sobre equipos de radio:

Informações de equipamento de rádio:

Radyo Ekipmanı Bilgileri:

Πληροφορίες περί ραδιοεξοπλισμού:

Informacije o radijski opremi:

Informacije o radijskoj opremi:

Information vedr. radioudstyr:

Radioaaltoja lähettävän laitteen tiedot:

Informasjon om radioutstyr:

Information om radioutrustning:

Informacja o urządzeniach radiowych:

Informace o rádiovém vyzářování přístroje:

Rádióhullám-kibocsátási adatok:

Informácie o rádiovom zariadení:

Informații privind echipamentele radio:

Informācija par radio iekārtu:

Radio ryšio įrangos informacija:

Raadioseadme teave:

Informazzjoni tat-Tagħmir tar-Radju:

Eolas faoi Threalamh Raidió:

2402 - 2480 MHz	max. 20 dBm (E.I.R.P.)
-----------------	------------------------

EU Declaration of Conformity

Konformitätserklärung

Déclaration de conformité

Declaración de conformidad

Dichiarazione di conformità

Verklaring van conformiteit

Izjava o skladnosti

Izjava o skladnosti

Prohlášení o shodě

Uyumluk Beyanı

Megfelelőségi nyilatkozat

Overensstemmelseserklæring

Försäkran om överensstämmelse

Vaatimustenmukaisuusvakuutus

Konformitetserklæring

Declaração de Conformidade

Δήλωση συμμόρφωσης

Deklaracja zgodności

Vyhlasenie o zhode

Vastavusdeklaratsioon

Atbilstības deklarācija

Atitikties deklaracija

Dikjarazzjoni ta' Konformità

Declarație de conformitate

Декларация за съответствие

https://download.starmicronics.com/manual/CE_DoC/SM-L200_CE_DoC_Newest.pdf

UK Declaration of Conformity

https://download.starmicronics.com/manual/CE_DoC/SM-L200_UK_DoC_Newest.pdf

Mexico Statement

LA OPERACIÓN DE ESTE DISPOSITIVO ESTA SUJETA A LAS SIGUIENTES CONDICIONES:

- a) Es posible que este equipo o dispositivo no cause interferencia perjudicial.
- b) Este equipo o dispositivo debe aceptar cualquier tipo de interferencia, incluyendo la que pueda causar su operación no deseada.

FCC Notice:

This device complies with Part 15 of the FCC Rules. Operation is subject to the following two conditions: (1) This device may not cause harmful interference. (2) This device must accept any interference received, including interference that may cause undesired operation.

NOTE: This equipment has been tested and found to comply with the limits for a Class B digital device, pursuant to Part 15 of the FCC Rules. These limits are designed to provide reasonable protection against harmful interference in a residential installation. This equipment generates uses and can radiate radio frequency energy and, if not installed and used in accordance with the instructions, may cause harmful interference to radio communications. However, there is no guarantee that interference will not occur in a particular installation. If this equipment does cause harmful interference to radio or television reception, which can be determined by turning the equipment off and on, the user is encouraged to try to correct the interference by one or more of the following measures:

- Reorient or relocate the receiving antenna.
- Increase the separation between the equipment and receiver.
- Connect the equipment into an outlet on a circuit different from that to which the receiver is connected.
- Consult the dealer or an experienced radio/TV technician for help.

WARNING: Changes or modifications not expressly approved by the party responsible for compliance could void the user's authority to operate the equipment.

RF Exposure

The equipment has been evaluated to meet general RF exposure requirement. The device can be used in portable condition without restriction.

IC Notice:

This device complies with Canada Industry licence-exempt RSS standard(s). Operation is subject to the following two conditions:

- (1) this device may not cause interference; and
- (2) this device must accept any interference. Including interference that may cause undesired operation of the device.

CAN ICES-3 (B)

Avis d'Industrie Canada

Le présent appareil est conforme aux CNR d'industrie Canada applicables aux appareils radio exempts de licence. L'exploitation est autorisée aux deux conditions suivantes:

- 1) l'appareil ne doit pas produire de brouillage; et
- 2) l'utilisateur de l'appareil doit accepter le brouillage radio électrique subi même si le brouillage est susceptible d'empêcher le fonctionnement normal de l'appareil.

Cet appareil numérique de la classe B est conforme à la norme NMB-003 du Canada.

CAN NMB-3 (B)

RF Exposure Statement: This product complies with the FCC and IC RF exposure limit set forth for an uncontrolled environment and is safe for intended operation as described in this manual.

Declaración de exposición a RF:

Este producto cumple con el límite de exposición a RF de la FCC e IC establecido para un entorno no controlado y es seguro para la operación prevista como se describe en este manual.

Trademark acknowledgments

SM-L200: Star Micronics Co., Ltd.

Notice

- All rights reserved. Reproduction of any part of this manual in any form whatsoever, without STAR's express permission is forbidden.
- The contents of this manual are subject to change without notice.
- All efforts have been made to ensure the accuracy of the contents of this manual at the time of going to press. However, should any errors be detected, STAR would greatly appreciate being informed of them.
- The above notwithstanding, STAR can assume no responsibility for any errors in this manual.
- iPad, iPhone, iPod touch, and Retina are trademarks of Apple Inc., registered in U.S. and other countries. iPad Air, iPad mini and lightning are trademarks of Apple Inc.
IOS is a trademark or registered trademark of Cisco in the U.S. and other countries and is used under license.
- Android is a trademark of Google Inc.
- Windows is a registered trademarks of Microsoft Corporation.
- The Bluetooth® word mark and logos are registered trademarks owned by the Bluetooth SIG, Inc.

Copyright © 2015-2022 Star Micronics Co., Ltd.

Caution Symbol



Caution for static electricity: Do not touch the print head as it may be damaged by static electricity accumulated in the human body.



Caution for burns: The print head may be hot. Do not touch the print head. There is a risk of burns.

Safety Precautions

Please be sure to read

To use this product in safety, please follow the precautions given below.

WARNING

- ✓ If you notice smoke, a strange smell, or a strange sound, turn off the power immediately, and remove the USB cable and/or battery pack. Then contact the dealer.
 - ✓ If any foreign material (metal scraps, water, or other fluid) enters the printer, immediately turn off the printer and remove the USB cable and/or battery pack. Then, contact your dealer for advice. Continued use of the printer could result in a fire.
 - ✓ Never attempt to repair the printer yourself. Also do not disassemble or modify the product. Doing so could lead to injury, fire, or electric shock.
 - ✓ Do not touch the tear bar.
 - There is a tear bar inside the paper outlet slot. Neither put your hand in the paper outlet slot while printing is in progress, or put your hand into the outlet even when printing is not in progress.
 - The printer cover can be opened when replacing the paper. However, since the tear bar is on the inside of the printer cover, be careful not to place your face or hands too close to the tear bar.
 - ✓ During and immediately after printing, the area around the thermal head is very hot. Do not touch it, as you could be burned.
 - ✓ If any battery fluid gets on your skin or clothing, immediately wash the affected area with fresh water. Otherwise, skin damage may result.
 - ✓ The battery pack may be hot immediately after the product has been used.
-

■ Using the Printer

- ✓ Some semiconductors can be damaged by static electricity. Be sure to turn off the printer when inserting or removing the battery pack.
- ✓ Do not drop the printer or hit it against a hard object.
- ✓ Do not open the printer cover while the printer is printing.
- ✓ Before you open the printer cover, make sure that printing data is not being sent to the printer.
- ✓ Do not unplug or plug in a USB cable while the printer is printing or during communication.
- ✓ Do not touch a USB connector while the printer is printing.
- ✓ Turn off the printer when you are not using it.
- ✓ When the printer is used in a low temperature environment, the battery's performance will be diminished, and the amount of time that you can use the printer for may be reduced.
- ✓ Do not pull out paper while the printer cover is closed.
- ✓ The heating element and the driver IC of the thermal head are easily damaged. Do not touch them with metal objects, sandpaper, etc.
- ✓ Printing quality may suffer if the thermal head heating element becomes soiled by being touched with your hands. Do not touch the thermal head heating element.
- ✓ There is a risk of damage to the driver IC of the thermal head from static electricity.
Never directly touch the IC.
- ✓ Do not operate the printer if there is moisture on the front surface of the head from condensation, etc.

■ Thermal Paper Handling

- ✓ Only use thermal paper with the designated specifications. The printing quality and working life of the thermal head cannot be guaranteed if any paper other than that recommended is used. In particular, if ion concentration of [Na⁺, K⁺, Cl⁻] is high, it may drastically reduce the working life of the thermal head. Please exercise caution.
- ✓ Store the thermal paper in a cool, dry, dark location.
- ✓ Do not rub the thermal paper with a hard object.
- ✓ Do not leave the thermal paper in contact with plastic film, an eraser, or adhesive tape for a long period of time.
- ✓ Do not stack the thermal paper on fresh diazo copies or wet-type copies.
- ✓ Do not use chemical glue on the thermal paper.
- ✓ Do not use thermal paper that has been stored for a long period .

■ Operating Environment for the Printer

Before actually unpacking the printer, you should take a few minutes to think about where you plan to use it. Remember the following points when doing this.

- ✓ Do not use the printer in an environment in which it will be subject to strong shaking while it is printing.
- ✓ Be careful to ensure that the printer is not exposed to direct sunlight.
- ✓ The appropriate environment for using the printer is described below.

Temperature: 0°C to 50°C

Humidity: 20% RH to 85% RH (no condensation)

- ✓ Do not place the printer near a copying machine or other device that produces a strong electromagnetic field.
- ✓ Keep the printer sufficiently removed from heaters and other sources of heat.
- ✓ Use the printer in a clean, low-humidity environment that is free from dust.
- ✓ Avoid using the printer in high-humidity rooms.

■ Printer Maintenance

Please perform the following maintenance every 6 months.

- ✓ Thermal head

Dip a cotton swab in an alcohol solvent (ethanol, methanol, or isopropyl alcohol), and clean the heating area of the head.

- ✓ Platen

While turning the platen, use a soft dry cloth to lightly rub the entire surface of the platen and remove any foreign objects.

- ✓ Paper storage unit and the surrounding area

Remove any dirt, dust, pieces of paper, etc., from the paper storage unit.

- ✓ Card reader

Regularly blow air onto the card reader to remove any dust from the card slot.

■ Using a Magnetic Card

- ✓ Do not bring magnets near the card, and do not store the card near a device that produces a magnetic field (such as a mobile phone, speaker, or TV). If you do so, the data on the card may be deleted.
- ✓ Do not leave the card in a high-temperature environment (such as the dashboard of a car). If you do so, the card may bend.
- ✓ Do not touch the card with dirty or wet hands. Also, do not attach adhesive tape or glue to the card. Failing to follow the above precautions could cause the card to stop working properly.

Table of Contents

1. Product Overview.....	1
1.1 Printer & Accessories.....	2
1.2 Appearance and Components.....	3
2. Setup.....	4
2.1 Battery Pack.....	4
2.1.1 Inserting into the Printer.....	4
2.1.2 Charging the Battery.....	5
2.2 Connecting a tablet or PC to the printer (pairing).....	9
2.2.1 iOS.....	10
2.2.2 Android.....	10
2.2.3 Windows10.....	11
2.3 Loading Paper.....	12
2.4 Belt Clip.....	14
2.4.1 Attaching to the Printer.....	14
2.4.2 Using the Belt Clip.....	14
3. Printer Features.....	15
3.1 Control Panel.....	15
3.1.1 Button.....	15
3.1.2 Panel Lamp.....	16
3.1.3 OLED Indication.....	16
3.1.4 Buzzer Description.....	17
3.2 Self Test.....	17
3.2.1 Self Test Procedure.....	17
3.2.2 Printing the Bluetooth Device Name and MAC Address.....	18
3.3 Memory Switch Settings.....	18
3.4 Instruction for Power Management.....	26
3.4.1 Standby Time.....	26
3.4.2 Auto-Off Time.....	26
3.4.3 Smart Power Option (Supported from firmware version 1.3).....	26
3.5 Magnetic Card Reader (For MSR model).....	27
4. Paper.....	29
4.1 Paper Specification.....	29
4.2 Recommended Paper.....	29
4.3 Printing Range.....	29
4.4 Specification of Black Mark.....	30
5. General Specification.....	31

6. Detailed Specification.....	34
7. Interface.....	46
7.1 USB.....	46
7.2 Bluetooth.....	47
8. Specifications of Accessories.....	48
8.1 Battery Pack.....	48
8.2 Belt Clip.....	48
9. Troubleshooting Procedure.....	49
9.1 Troubleshooting Guide.....	50
9.1.1 Power Supply Failure.....	50
9.1.2 Printing Failure.....	50
9.1.3 Faulty Sensor.....	51
9.1.4 Paper Feed Failure.....	51
9.1.5 Error Message(Printer Status indication on the OLED).....	52
10. Fitting Regulations.....	53
10.1 Printer.....	53
10.2 Battery Pack.....	53
11. Revision History.....	54

1. Product Overview

This printer is perfect for mobile banking systems, retail, POS (point of sale) terminals and other forms of mobile computing.

The characteristics of this printer are listed below:

- Pocket size (83x122.5x44mm)
- Extremely light and mobile (220g including Battery pack)
- Ultra-long standby time(20h) and continuously work for 1.2 hours
- 1.2m Drop Resistance
- Very silent printing thru direct thermal printing method
- Print speed 35mm/s (Paper feed 70mm/s)
- Support Bluetooth Ver3.0/4.0[BLE] Dual Mode
- Support Secure Magnetic Stripe Reader <Model with Card Reader>
 - *AES or 3DES encryption
 - *DUKPT Key Management
- Support Graphic OLED(128x64 dots) with Blue Backlight
- Belt Clip as a standard accessory
- Support text and graphic printing
- Drop-in design that makes it easy to load paper
- A printer cover that can be opened with the touch of a button
- Printer cover open sensor, Paper-out sensor and Black mark sensor

1.1 Printer & Accessories

The printer is packaged with the following accessories.

If any of these accessories is broken or missing, please contact the dealer that you bought the product.



Printer

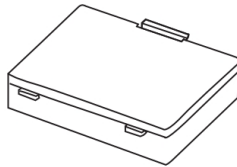

Battery Pack

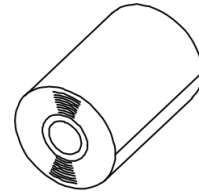

Printer paper sample

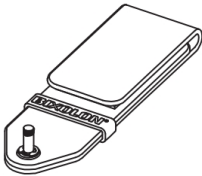

Belt Clip

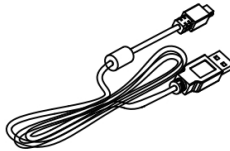

USB Cable

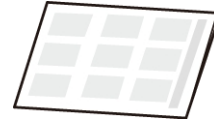

Safety Instruction Sheet



Easy Setup Guide

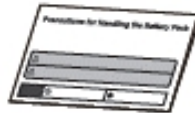

Safety Instruction Sheet
For Battery Pack

The optional items for this printer are listed below.

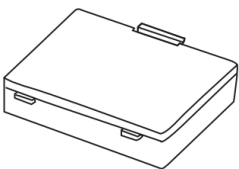

Battery Pack

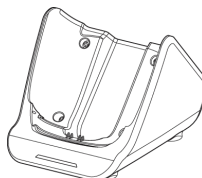

Charging Cradle

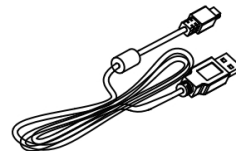

USB Cable

1.2 Appearance and Components

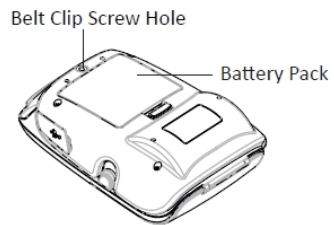
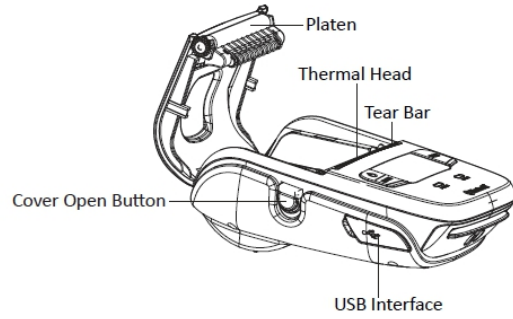
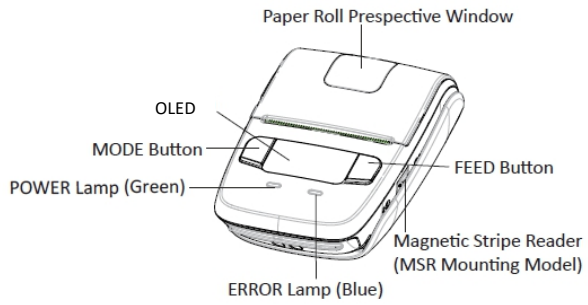

2. Setup

2.1 Battery Pack

2.1.1 Inserting into the Printer

1. Make sure that the printer has been turned off before you insert or remove the battery pack.
2. Insert the battery pack into the back of the printer as in the figure shown below, following the direction of the arrow.

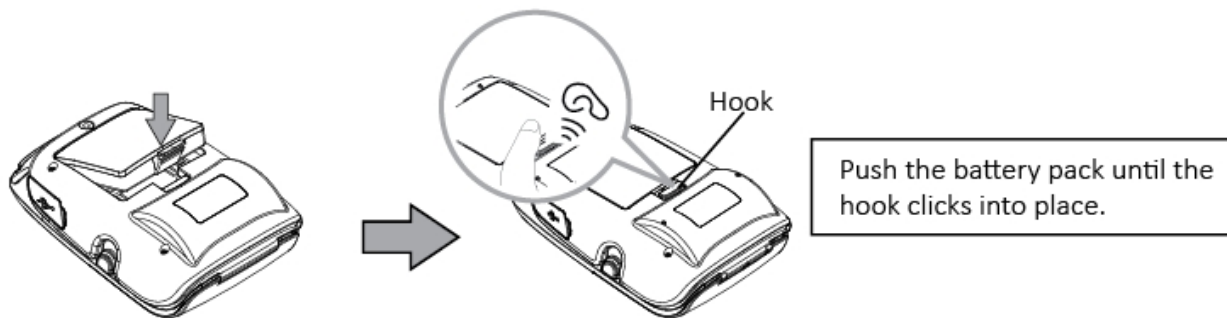

3. To remove the battery back, pull back the hook, and use the opposite procedure from the one you used to insert the battery pack.

2.1.2 Charging the Battery

Insert the battery pack into the printer to charge it.

Plug in socket with USB charging.

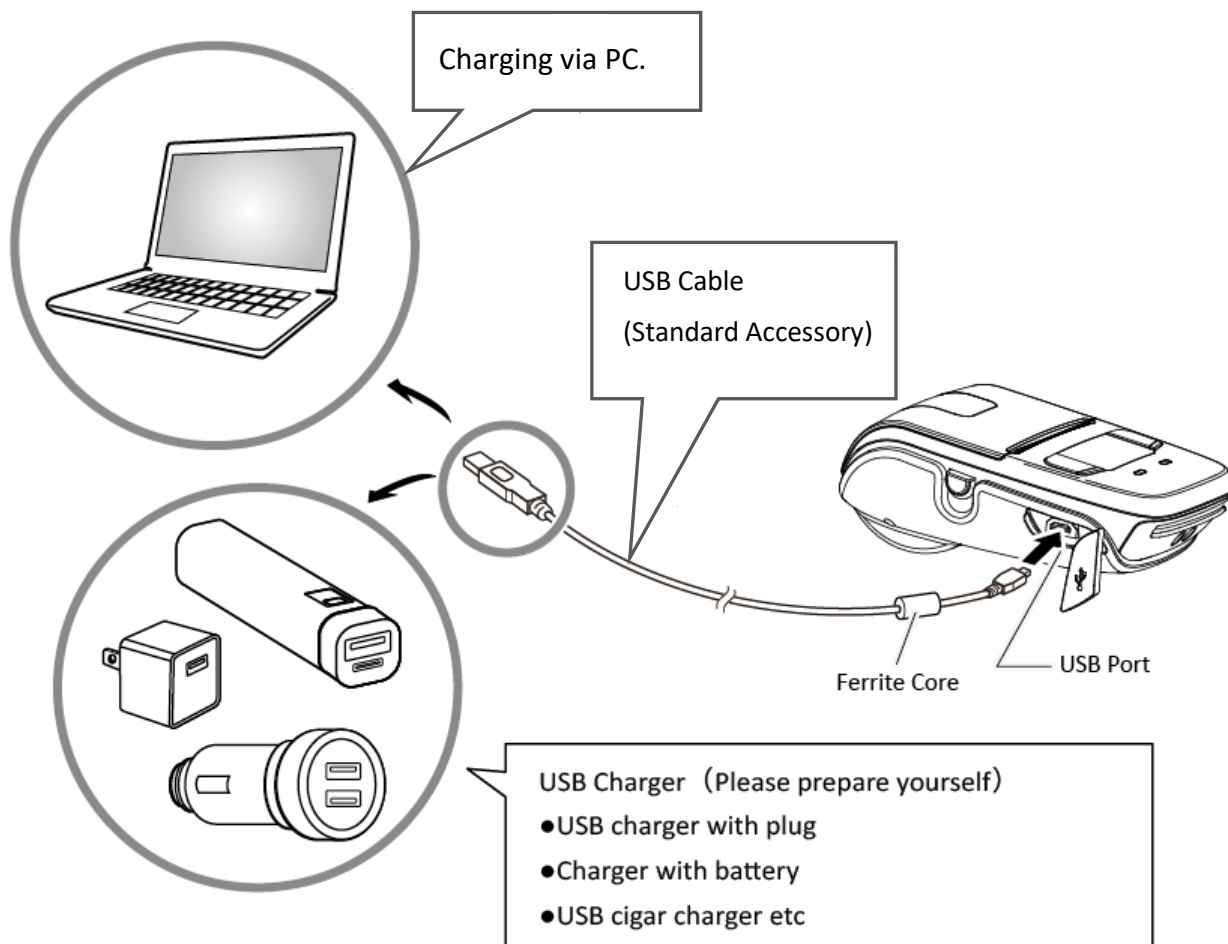

When battery pack runs out of power, the battery icon will flash. It powers off automatically when continues printing. If you want to go on, please charge it.

Battery charging status descriptions are as follows:

Printer Status	While Charging	Charging is completed
When power ON	Power lamp is Flashing in green	Power lamp is constant on *But if printer goes into Stand-by mode, power lamp will keep flash 1 time/second.
When power OFF	Power lamp is Flashing in green	Power lamp is off

NOTE: However, a low-grade car charger may cause a trouble due to a sudden change of voltage.

Use the charger that satisfies the USB standard.

▶ Charging control while the USB cable is connected: (Firmware version 3.2 or later)

- When the power is turned on:

When a USB charger or PC is connected to this product with a USB cable, it will stop charging after charging to full capacity.

After that, it will start charging again when the battery level drops to about 50%, and stop charging when it reaches about 80% of full charge.

After that, the system automatically repeats this process.

- When the power is off:

When this product is connected to a USB charger or PC with a USB cable, it will charge the battery to full capacity and then stop charging after a certain period of time.

After that, charging will not resume, regardless of the remaining battery level.

If you want to recharge the battery, press the [MODE] button or remove and insert the USB cable.

- If you want to charge the battery to full capacity, turn off the printer and connect the product to a USB charger or PC with a USB cable.



Notes about the Battery Pack

General Battery Characteristics

- The battery is a consumable and its performance over time gradually decreases.
- While not in use, the battery will slowly discharge itself.
Prepare a battery pack that has been charged relatively recently (1 to 2 days earlier).
- To ensure that the battery lasts for a long time, we recommend that you turn off the printer whenever possible.
- When used at low temperatures, battery performance will temporarily decline. Be sure to have a fully-charged spare battery standing by if the printer will operate in a cold environment.

Charging the Battery Pack

- The battery pack can be charged at ambient temperatures between 0 and 40°C.
- The time required to charge the battery pack varies depending on the voltage and the ambient temperature. Normally, it takes 4 to 5 hours to charge the battery pack.
- It will take longer to charge the battery pack if you print while charging the battery pack.
- Do not remove the battery pack while it is being charged.
- Fully charge the battery prior to using the printer. Otherwise, the performance of the battery may be affected.
- When the battery is out of charge, charging starts even if the Power LED does not blink immediately after charging starts. The Power LED will start blinking within an hour.
- There is no need to completely discharge or use up a rechargeable Lithium-ion battery before recharge it.
- It is normal for the battery pack to be hot after it has finished charging or been used.
- Do not recharge a battery pack that has just been fully charged.

Battery Pack Life

- The battery can be charged approximately 300 times in the normal temperature range without losing performance. If an extreme decline in the running time of the battery is noticed, the battery is reaching the end of its usable life. It is recommended to replace the old battery with a new one.

Notes about Using the Battery Pack

- Only use a designated battery pack.
- Only use the designated battery charging method.
You cannot use a USB cable other than the designated USB cable.
- Do not throw the battery into a fire, place it near a flame or heating device, or leave it in a hot environment (under direct sunlight, in a car, etc.).
- Do not use a battery pack that has been dropped or subjected to a shock in some other way.
- Do not disassemble or modify the battery pack.
- Do not short the terminals of the battery pack or get it wet.
- Do not place the battery pack in a bag with a small metal object (such as a key).
- If any battery fluid gets on your skin or clothing, immediately wash the affected area with fresh water. Otherwise, skin damage may result.

Notes about Storing the Battery Pack

- The characteristics of the battery pack may degrade if you store it in a charged state for a long period of time. If you do not intend to use the battery pack for a while, use up its power before storing it.
- If you do not intend to use the battery pack for a long time, be sure to remove it from the printer.
- Keep the battery out of the reach of children. In addition, be careful that children do not remove the battery.
- Store the battery pack in a cool place.

* We recommend that you store the battery pack in a dry area with an ambient temperature of 15 to 25 °C.

* Avoid storing the battery in locations with high or extremely low temperatures.

Battery Disposal and Recycling

A battery pack is used to power this device. Since the disposal process of batteries varies from country to country, refer to the appropriate measures mandating the disposal method of the country in which this device is used.

< For U.S.A. and Canada >



Lithium-Ion batteries are recyclable. You can help preserve our environment by returning your used rechargeable batteries to the collection and recycling location nearest you. For more information regarding recycling of rechargeable batteries, call toll free 1-800-822-8837, or visit <http://www.rbrc.org/>

If battery pack is not in use for a long time, please remove it after fully charged. And it should be recharged every 3 months.

When power is low, battery should be charged in time. If the printer automatically power down because of low power, be sure to charge the battery in 15 days. Otherwise, it will cause permanent damage to the battery.

2.2 Connecting a tablet or PC to the printer (pairing)

1. Press and hold MODE button for approx. 2 seconds, and printer is turned on.

Then, it is ready to pair with another Bluetooth device.

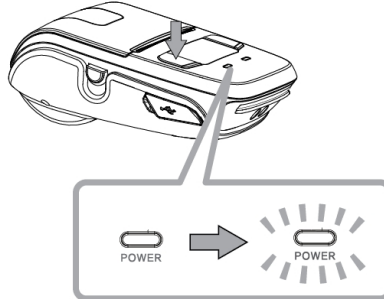

2. If necessary, enter the following information into the terminal that you are using.

PIN: 1234 (default)

Device name: "STAR L200-XXXXX" (default)

Device name: "STAR L204-XXXXX" (MSR model)

(XXXXX is the last digits of the Product Serial Number)

Notes:

1. SM-L200 has two Bluetooth modes:

a) One is Bluetooth Ver3.0 with PIN for Android or Windows system. PIN and Device name can be changed through Star Utility. To obtain this utility, please contact with your dealer.

b) Another is Bluetooth 4.0(BLE) without PIN for iOS system.

2. SM-L200 changes the Bluetooth mode automatically by host system

3. Pairing sets one by one in order, otherwise it can't figure out which one succeeds in pairing.

The Bluetooth® word mark and logos are owned by the Bluetooth SIG, Inc. and any use of such marks by Star is under license. (Design and specifications subject to change without notice.)

You can test the connectivity with a host device by using StarIO SDK Application which is available on Apple Store and Google play

2.2.1 iOS

1. Press and hold MODE button for approx. 2 seconds, and printer is turned on.
2. Pairing is not required. Select the model from your application.

Device name: "STAR L200-XXXXX"(default)

(XXXXX is the last five digit number written in the "Serial No." column on the bottom of the printer.)

2.2.2 Android

1. Press and hold MODE button for approx. 2 seconds, and printer is turned on.
2. Open the tablet settings screen and select Bluetooth.

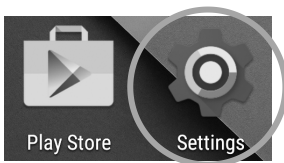

3. Turn ON Bluetooth.

Select the displayed device name (STAR L200-XXXXX), and enter the PIN code.

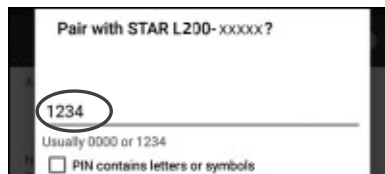
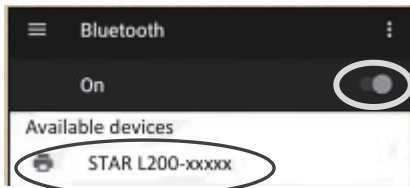

4. When the device name is displayed under "Paired devices", pairing is completed.

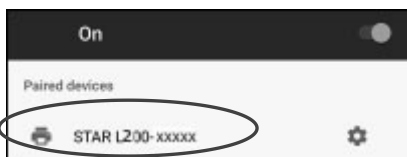

2.2.3 Windows10

1. Press and hold MODE button for approx. 2 seconds, and printer is turned on.
2. Open SETTINGS , select [Devices] - [Bluetooth].

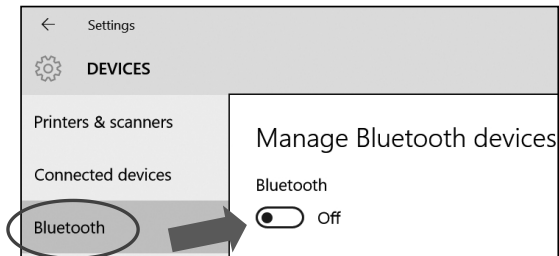

3. Turn ON Bluetooth.

Select the displayed device name (STAR L200-XXXXX), and enter the PIN code.



4. When "Connected" is displayed, pairing is completed.

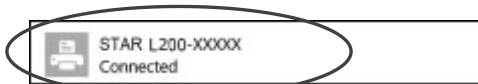

You can test the connectivity with a host device by using Star IO SDK Application which is available on Apple Store and Google play.

2.3 Loading Paper

Refer to Section 4 “Paper” (p. 25), to select roll paper that conforms to the specifications.

1) Press the cover open button to open the paper cover.

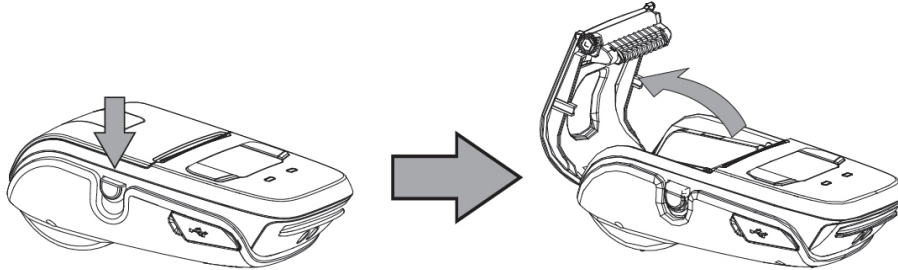

2) Load the roll paper in the orientation shown in the figure below.

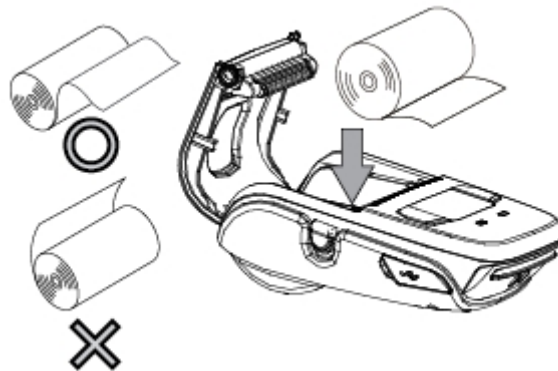

3) Pull the end of the roll straight toward you. Then press down on both sides of the printer cover to close it firmly. When you close the printer cover, make sure that it is closed on both sides.

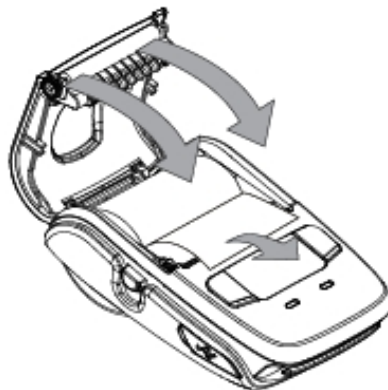

4) Use the tear bar to cut the extra paper.



CAUTION

When ERROR lamp is flashing, please make sure the cover is closed correctly. If it's not, open the cover and close it correctly.

When the paper is jammed, be sure to open the printer cover before removing the jammed paper.

Do not under any circumstances try to pull out the jammed paper forcefully while the printer cover is closed, doing so may damage parts of the printer.

Caution Symbol



Caution for static electricity: Do not touch the print head as it may be damaged by static electricity accumulated in the human body.



Caution for burns: The print head may be hot. Do not touch the print head. There is a risk of burns.

WARNING

1) Do not touch the tear bar.

- There is a tear bar inside the paper outlet slot. You could neither put your hand in the paper outlet slot while printing is in progress nor put your hand into the outlet even when printing is not in progress.
- The paper cover can be opened when replacing the paper. However, since the tear bar is on the inside of the paper cover, be careful not to place your face or hands too close to the tear bar.

2) During and immediately after printing, the area around the thermal head is very hot. Do not touch it, as you could be burned.

2.4 Belt Clip

2.4.1 Attaching to the Printer

Follow the procedure below to attach the belt clip to the printer.

1. Make sure that you are attaching the belt clip in the right orientation, then screw the screw that comes with the belt clip into the designated screw hole to attach the belt clip to the printer.
2. Use a coin to firmly screw in the screw.

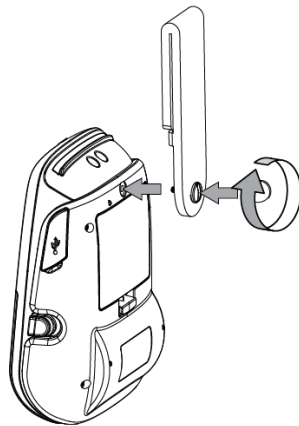

2.4.2 Using the Belt Clip

When the printer is attached to your belt, you can use it like the picture below.

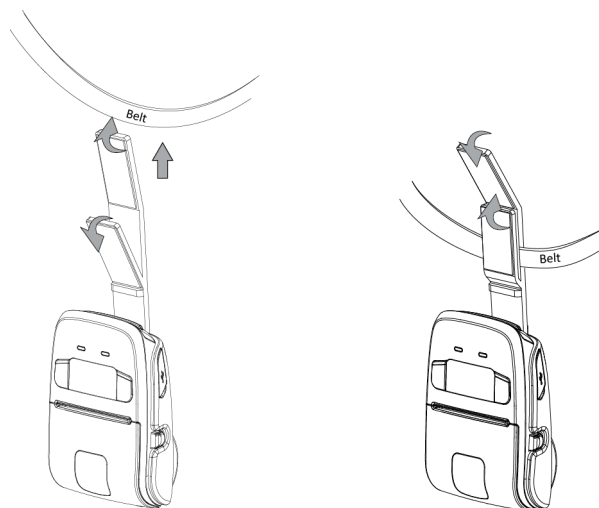

Note: Be careful not to drop when use a belt clip. Velcro be securely fixed.

Hold the printer firmly with your hand when you swipe a magnetic stripe card or cut paper. If it is not held firmly, you may fail to read card data or cannot cut paper smoothly with the tear bar.

3. Printer Features

3.1 Control Panel

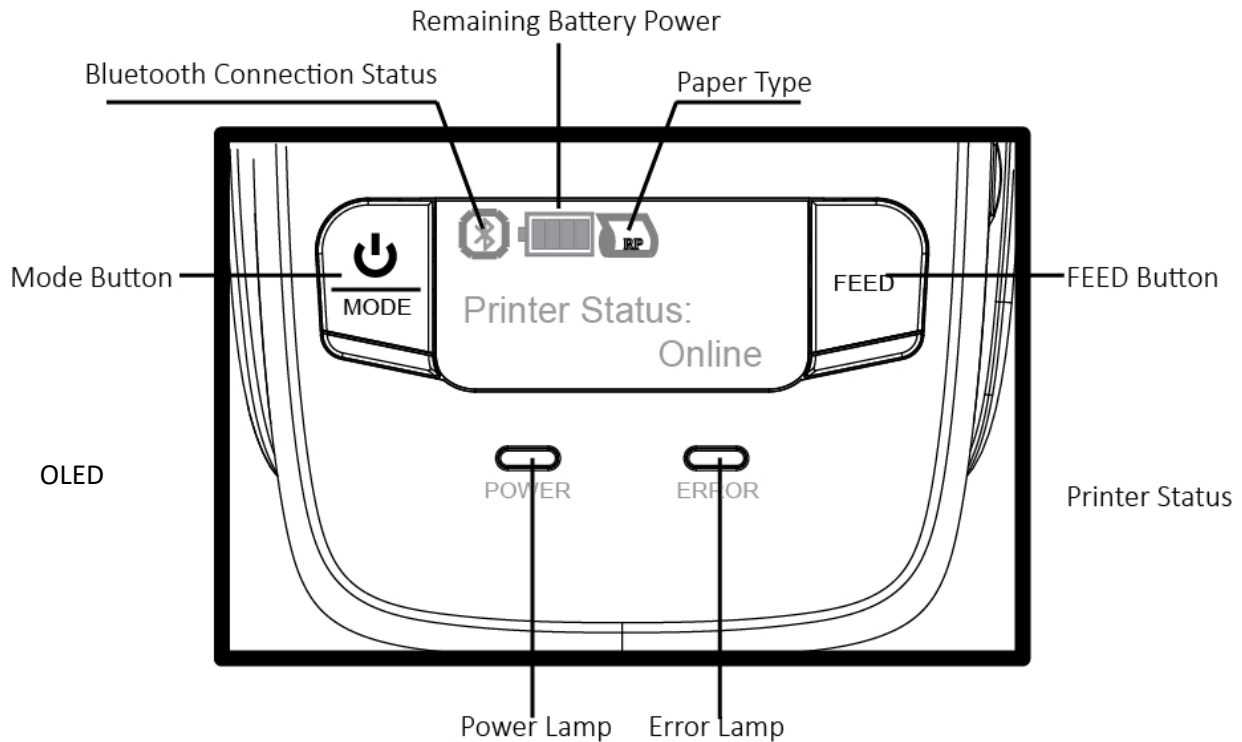

3.1.1 Button

1) MODE Button:

- ① Pressing and holding the MODE button for 2 seconds or more will turn the power on or off.
- ② Pressing and holding MODE & FEED buttons for 5 seconds will put the printer into Memory Switch Setting mode. The MODE button can now be used to change Printer MODE status visible on the OLED screen for fast configuration .

(Refer to 3.3 Memory Switch Settings for details about mode conversion)

2) FEED Button :

- ① When the printer is on, paper can be fed manually by pressing and holding the FEED button for more than one second.
- ② In Memory Switch Setting mode, the FEED button can be used to move cursor(“_”) and confirm the new setting.

3.1.2 Panel Lamp

- 1) **POWER (Green):** Printer is ON and ready to receive data.
- 2) **ERROR (Red):** Indicates an error has occurred. (Ex.: Paper Out, Cover Open, etc)

Power lamp (green)	Error lamp (blue)	Status
Flash	OFF	Power-on charging
Flash	OFF	Power-off charging
ON	OFF	Power-on charging , Battery full
OFF	OFF	Power-off charging , Battery full
ON	OFF	Power on
Flash	OFF	Standby
ON	Flash	Paper out
ON	Flash	Cover open

3.1.3 OLED Indication

OLED will display most of the printer status.





1) The 128 x 64 dots display shows alphanumeric characters.

2) Content



Mode/Status: Indicates the currently specified printer mode or error status.

Remaining battery power :

No Charging

Icon	Battery Status and Voltage
	Empty 3.6~3.7V The remaining battery power is extremely low. *Less than 3.6V Please turn off the printer
	1 bar 3.7~3.8V The remaining battery power is low. Please charge the battery pack
	2 bars 3.8~3.9V
	3 bars 3.9~4.0V
	4 bars Above 4.05V There is sufficient remaining battery power.

While charging

Icon	Battery Status and Voltage
	Charging Below 4.1V
	4 bars Above 4.05V

Bluetooth connection status



The mark on the left indicates that there is no Bluetooth connection.



The mark on the left indicates that there is a Bluetooth connection

Paper type



Receipt



Black mark (Front)



Black mark (Back)



Out of paper

3.1.4 Buzzer Description

Buzzer	Status
No ring	Low battery
Once	Begin charging/Press button/Cover close
Twice	Paper out/Cover open
Thrice	USB disconnected

3.2 Self Test

You can use self test to check the printer's settings.

Before you start the self test, make sure that roll paper has been properly loaded into the printer.

3.2.1 Self Test Procedure

- 1) Turn on the power while holding down FEED.
- 2) The printer will print the current printer status, including the firmware version, communication mode, print settings and QR code that links to the users Manual Download site.
- 3) The self test will finish automatically. The printer will be ready to receive data after the self test finishes.

3.2.2 Printing the Bluetooth Device Name and MAC Address

- 1) Follow the procedure in section 3.2.1 to perform a self test.
- 2) Before the self test finishes, press and hold FEED and MODE at the same time.
- 3) The printer will print the Bluetooth device name and MAC address, and the self test will finish automatically.

The printer will be ready to receive data after the self test finishes.

*** SM-L204 ***
[Ver: 3.0 2018/12/17]
S/N: XXXXXXXXX
BatteryVoltage: 3.98 V

PORT = USB
PORT = Bluetooth

DENSITY = MID(MID SPEED)
STANDBY = 60 s
SMART POWER OPTION = Disable
AUTO OFF = No use
PAPER = Receipt

Get Users manual

www.starmicronics.com/support

BD Name:
STAR L200-00003

BD Addr:
34-81-F4-36-62-13

-- Memory Switch --
FEDCB9876543210 HEX.
<0> 0000000000000000 0000
<1> 0000000000000000 0000
<3> 0000000000000000 0000
<7> 0000000000000000 0000
 0000000000000000 0000

-- Memory Switch Detail--
<0>F = Emulation:StarPRNT
<0>4 = Character Mode:Standard
<1>4 = Zero Style:Normal Zero
<1>3-0= Inter. Char:USA
<3>F-8= Page:Normal
<3>4 = ANK Pitch:12 dot
<3>0 = Feed Pitch:4 mm
<7>C = ASB:Valid
<7>8 = NSB:Valid
F = Data Time Out:Valid

Self-Test Information

User's Manual Address

Bluetooth Device Name and MAC Address

Self-Test Information

3.3 Memory Switch Settings

Change the Memory switch by following operations. (Refer to P16 “Memory Switch Setting Table”).

1. Press and hold MODE button for approx. 2 seconds, and printer is turned on.

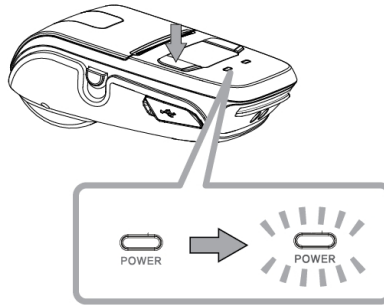

2. To put the printer into Memory Switch Setting mode, press and hold both the MODE & FEED buttons for 5 seconds. After printer displays “Enter Menu Mode”, you can configure the settings. Release the buttons after you surely confirm the screen display “Enter Menu Mode”, to get a printer into the setting mode.



3. To switch the Menu and option parameter, or return to the previous menu, press MODE button.

4. To move the cursor (“_”), enter the printer mode, or confirm the new setting, press FEED button.

CAUTION

Before changing the memory switch settings, make sure that the communication with a host device is disconnected.

When the printer is under the Bluetooth communication with a host device, it cannot enter the Memory Switch Setting mode.

Example

When you want to change the settings of the printer mode as shown below,

Item	Factory Setting	Configuration Example
1 Density	0(Medium)	1(Low)
2 Standby Time	0060(Sec)	0080(Sec)
3 Auto Off Time	0000(Invalid)	1000(Min)
4 Smart Power	0(Disable)	0(Disable)
5 Paper Type	0(Receipt)	2(BM(Back))
6 Factory Reset	0(Cancel)	0(Cancel)
7 Password	0000	2222
8 Previous Menu	---	---

Press and hold the MODE & FEED buttons for 5 seconds.

→You will see present “Enter Menu Mode” in the OLED.

Press the MODE button once to switch the menu item.

Display: 1 Self Test →2 System Setting

Press the FEED button once to get into the System Setting menu.

→You will see present “Input Password 0000” in the OLED.

→Press FEED button to move cursor(“_”),Press MODE button to switch the number (0~9).

Password: 0000(default)

→Press and hold the FEED button for 2 seconds to get into the menu.

- Display:
- 1 Density
 - 2 Standby Time
 - 3 Auto off Time
 - 4 Smart Power

[Density]

Press MODE button to switch the menu item,then press the FEED button once to enter the menu.

→Press the FEED button once to get into the Density menu.

- Display: Density:
- 0-Medium 1-Low
 - 2-High 0
 - 3-Special

→Press the MODE button once to input the number 1, then press and hold FEED button to confirm the new setting and return to the previous menu.

(The density has set to Low)

0(Medium) → 1(Low)

Please use at a room temperature if you want to set the density to '3 Special'.
Some type of the paper are not suitable for use in low temperature environment.

[Standby Time]

Press the MODE button once to switch the menu item--Standby Time.

→Press the FEED button once to get into the menu.

Display:	Standby Time:
	[0010-9999(Sec)]
	<u>0</u> 060

→Press the FEED button twice to move cursor(“-”), then press the MODE button twice to input the number: 8, finally press and hold FEED button to confirm the new setting and return to the previous menu.

(The standby time has set to 80 seconds)

0060(Sec) →0080(Sec)

When set the parameter to 0000, the standby time becomes invalid.
 If set the parameter to 001~ 009, a buzzer beeps, so do not set it.

[Auto Off Time]

Press the MODE button twice to switch the menu item--Auto Off Time.

→Press the FEED button once to get into the menu.

Display:	Auto Off Time:
	[0001-9999(Min)]
	<u>0</u> 000

→Press the MODE button once to input the number on : 1, then press and hold FEED button to confirm the new setting and return to previous menu.

(The auto off time has set to 1000 minutes)

0000(Min) →1000(Min)

When set the parameter to 0000, the auto off time becomes invalid.

[Smart Power]

Press the MODE button 3 times to switch the menu item--Smart Power.

→Press the FEED button once to get into the menu.

Display:	Smart Power
	0-Disable
	1-Enable <u>0</u>

→Press the MODE button once to input the number on : 1, then press and hold FEED button to confirm the new setting and return to previous menu.

[Paper Type]

Press the MODE button 4 times to switch the menu item--Paper Type.

→Press the FEED button once to get into the menu.

Display:	0-Receipt	
	1-BM(Front)	
	2-BM(Back)	<u>0</u>

→Press the MODE button twice to input the number:2, then press and hold FEED button to confirm the new setting and return to the previous menu.

(The paper type has set to BM(Back))

0(Receipt) →2(BM(Back))

[Factory Reset]

Press the MODE button 5 times to switch the menu item--Factory Reset.

→Press the FEED button once to get into the menu.

Display:	0-Cancel	
	1-Factory Reset	
		<u>0</u>

→When the setting does not need to be reset, press and hold FEED button to return to the previous menu.

[Password]

Press the MODE button 6 times to switch the menu item--Password.

→Press the FEED button once to get into the menu.

Display:	Input New	
	Password	
		<u>0000</u>

→Press the MODE button twice to input the number: 2, then press FEED button once to move cursor("-"), press the MODE button twice to input the number:2, repeat the above steps to input the number "2222", finally press and hold FEED button to confirm the new setting and return to the previous menu.

(The Password has set to 2222)

0000→2222

[Previous Menu]

Press the MODE button 7 times to switch the menu item--Previous Menu.

→Press the FEED button once to return to the previous menu.

Display: 1 Self Test
 2 System Setting
 3 Exit Menu

[Self Test]

Press the MODE button 2 times to switch the menu item--Self Test.

Press the FEED button once to enter the menu item--Self Test.

Display: 1 Print
 2 MSR
 3 MSR Key Inject
 4 Hex Dump Mode
 5 Previous Menu

→Press the FEED button once,you will see present “Press Feed To Print” in the OLED, press FEED button, the new settings will be printed.

If the settings were not configured correctly, follow the above procedure to configure the settings again.

Memory Switch Setting Table

First-level menu		Second-level menu	Third-level menu	Default
1 Self Test		1 Print	Press Feed To Print	--
		2 MSR	Please Swipe Card	--
		3 Hex Dump Mode	Hex Dump Mode	--
		4 Previous Menu	--	--
2 System Setting	Input Password: 0000	1 Density	0-Medium 1-Low 2-High 3-Special	Medium
		2 Standby Time	Standby Time: [0010-9999(Sec)]	60 Seconds
		3 Auto Off Time	Auto Off Time:[0001-9999(Min)]	0000 Min
		4 Smart Power	Smart Power 0-Disable 1-Enable	0
		5 Paper Type	0-Receipt 1-BM(Front) 2-BM(Back)	Receipt
		6 Factory Reset	0-Cancel 1-Factory Reset	Cancel
		7 Password	Input New Password: 0000	0000
		8 Previous Menu	--	--
3 Exit Menu		--	--	--

3.4 Instruction for Power Management

The printer in the Standby(Sleep) Mode will recover to the Print Ready Mode when receiving print data or button operations.

Press the FEED button or the MODE button and confirm that the Power lamp(Green LED) is turned on. When the Power lamp is not turned on, it is possible that the printer is turned off by the Power OFF mode. In this case, turn the printer on manually.

3.4.1 Standby Time

Display on OLED is disappeared when a setting time has passed.(0010-9999 sec)

3.4.2 Auto-Off Time

The power is turn off when a setting time has passed.(0001-9999 min)

3.4.3 Smart Power Option (Supported from firmware version 1.3)

The smart power option is a function to turn on the printer when it is supplied the power.

When the printer is turned off, upon being powered, it will automatically turn on.

Please press and hold the MODE button to turn off the printer when it is supplied the power.

<If AUTO OFF is enabled>

If the smart power option is enabled and printer is turned on and powered, AUTO OFF function will be disabled.

In this case, AUTO OFF function will be enabled after power is interrupted.

For instance, if AUTO OFF is set to 10 minutes and,

The smart power option enabled, printer turned on and powered, then printer will NOT be turned off after 10 minutes.

The smart power option enabled, printer turned on and NOT powered, then printer will be turned off after 10 minutes.

Event		Event1	Event2	Event3	Event4
		Powered	Powered Interrupted	Auto Power OFF Time out	Charging completed
Condition 1	Turned OFF No charging	Turn ON (Auto) Start charging	N/A	N/A	N/A
Condition 2	Turned OFF Charging	N/A	Turn OFF No charging	N/A	Turn OFF Charging
Condition 3	Turned ON No charging	Turn ON (Auto) Start charging	N/A	Turn OFF No charging	N/A
Condition 4	Turned ON Charging	N/A	Turn ON No charging	Turn ON Charging	Turn ON Charging

3.5 Magnetic Card Reader (For MSR model)

Please keep the following points in mind when reading a card.

- Swipe the card with its magnetic stripe side towards the printer.
- Hold the card in the center and swipe it straight at a steady speed in the directions of arrows. You can swipe the card in either direction to read the data.

Be sure to hold the printer firmly with your hand while swiping.

➤ *Pay attention to the hand you hold the printer, your finger should not touch the cover of the MSR slot, if not, the card cannot be read properly. (See correct example on Figure 3.4-2)*

If you hold the corner of the card, it is difficult to swipe it straight so that you may fail to read the card data. So hold the card in the center when you swipe the card.

Figure 3.4-1

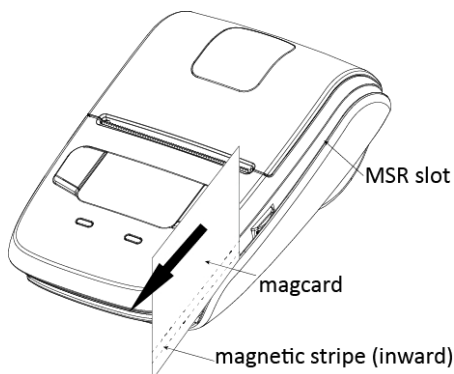
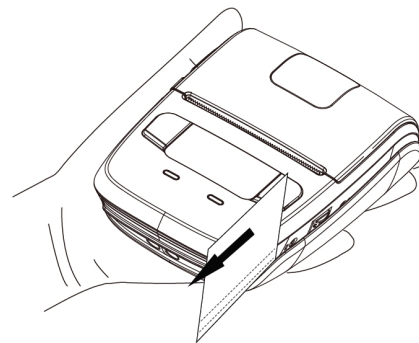

Figure 3.4-2



- A buzzer will sound once when a card is successfully read, and you will see present "MSR read success" in the OLED.
- When the printer fails to read the card, the buzzer will sound three times and you will see present "MSR read failure" in the OLED. Please check the orientation of the card, and slide it through the reader slot again.

Note:

1. Swiping JIS card is also under MSR mode.

2. JIS card operation is same as MSR card operation.

■ Correct example:

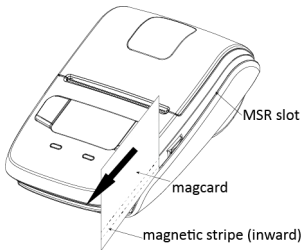

Make sure the magnetic stripe is towards to the magnetic head. Hold the card in the center as illustrated below and swipe it straight at a steady speed in the direction of arrows.

Incorrect example:

To grasp a magnetic card

If you grasp the front/rear part of a card and move it through the MSR slot, the front /rear part is loose and a read error occurs.

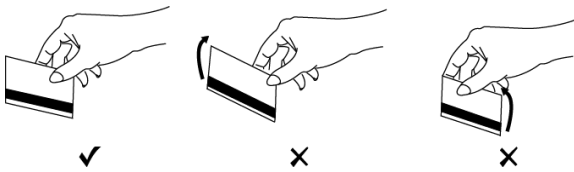

To move a magnetic card

If you insert a card tilted upward/downward into the MSR slot, the card does not move horizontally and a read error occurs.

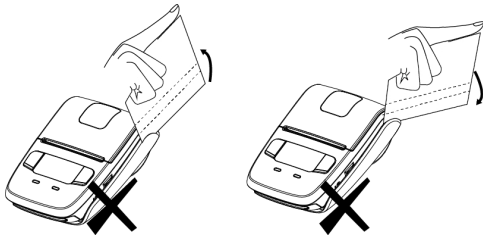

If you extract a card at the end of the MSR slot by lifting up or lowering down, the card is not maintained and a read error occurs.

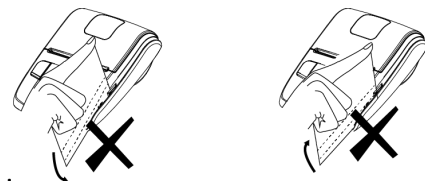

If you insert a card into the middle part of the MSR card, the card is not read correctly and read error occurs, or if you move the card back or forth by force after inserting into the MSR slot, the card is not read correctly and a read error occurs.

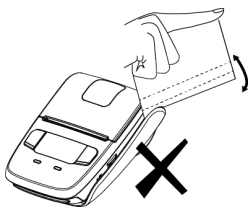

4. Paper

4.1 Paper Specification

Paper type	Thermal paper
Paper width	58mm
Paper thickness	$0.053\text{mm} \leq X \leq 0.12\text{mm}$
Roll paper diameter	$13\text{mm} \leq \varnothing \leq 40.5\text{mm}$

4.2 Recommended Paper

Paper Type	Manufacturer	Product Name
Thermal Paper	Mitsubishi Paper Mills Limited	P220AG
	Oji Paper Co., Ltd.	FD200
		PD160R-63
		PD450
	Domtar (Appvion)	Domtar POS 48S-2.1 (Alpha 400-2.1)

4.3 Printing Range

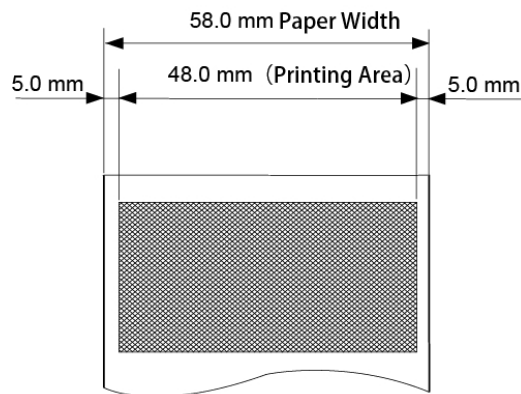

CAUTION

- 1) Do not use roll paper whose end is glued to its core, because the printer will be unable to properly detect the end of the paper. Also, we recommend that you use roll paper that has a roll end mark at its end.
- 2) Chemicals and oil may cause the roll paper to change color or cause the printed characters to become lighter.
- 3) Please be aware that the roll paper can be affected by heat, humidity, and direct sunlight.
- 4) The roll paper may change color if you scratch it with your fingernail, a hard piece of metal, etc.

4.4 Specification of Black Mark

SM-L200 supports black mark on both sides of the paper and the specification of black mark is illustrated by the following image.

• Thermal paper

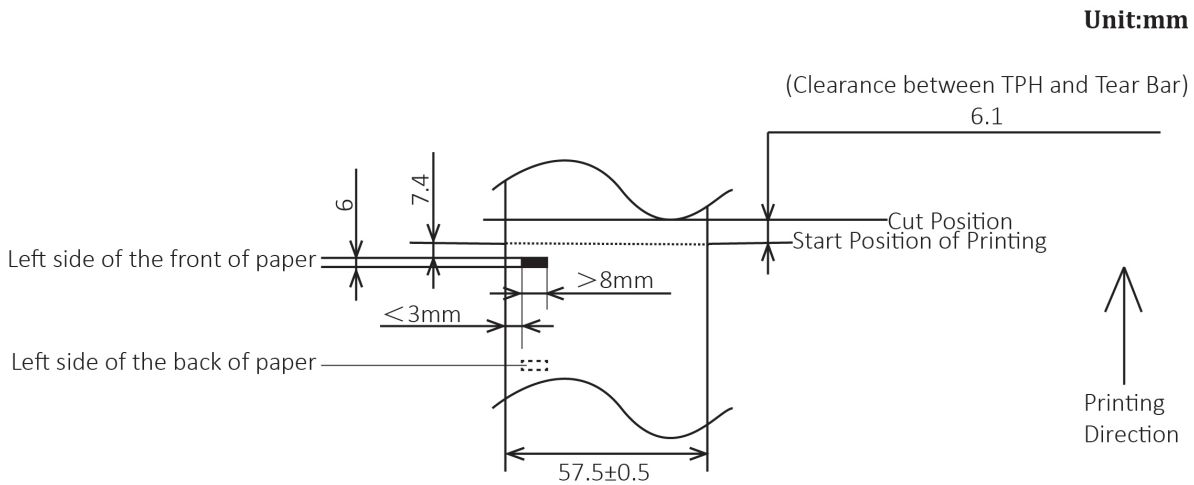

• Label paper

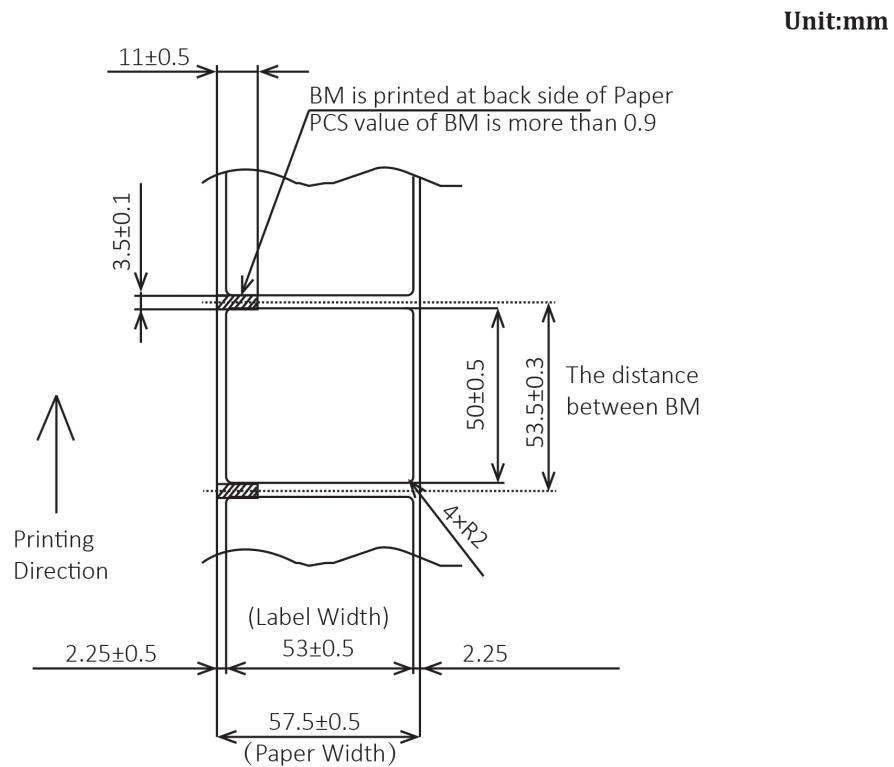

Note: PCS value of BM should be more than 0.9

5. General Specification

Table 5-1 General Specification

(1/2)

Item		Specifications	
Printing	Printing method	Direct line thermal printing	
	Resolution	203dpi (8dots/mm)	
	Printing speed	35mm/s	
	Valid printing width	48mm (384dots)	
Interface	Bluetooth	Bluetooth Spec	Bluetooth Ver 3.0/4.0 [BLE] Dual Mode
		Frequency range	2.4GHz ISM band
		Data transmission rate	115200bps adjustable
		Data bit	8 data bit fixed
		Parity bit	No parity fixed
		Stop bit	1 stop bit fixed
	USB	Micro-USB *1	
Power saving	Sleep mode	YES	
Character Set	Font	Alphanumeric: 9x17, 9x24, 12x24 dots Kanji:24x24 dots	
Barcode Symbologies	1D	UPC-A, UPC-E, EAN8, EAN13, CODE39, ITF, CODE128, CODE93	
	2D	QR code, PDF417	
Graphics		Support bitmap printing with different density and user defined bitmap printing (Max. 512K for total)	
Detection	Sensors	Printer cover open sensor, Paper-out sensor and Black mark sensor	
LED lamp	Power lamp	Green	
	Error lamp	Blue	

*1. Only for the printer which "BT/USB" is displayed in the ID seal.

Table 5-1 General Specification(Continued)

(2/2)

Item		Parameter
Charging		USB charge Output DC 5V $\overline{\text{---}}$ 0.5A, Time required for full charge: 5H
Power supply	Battery	1700mA 3.7V rechargeable battery pack
	Battery operating time	Approximately 13 hour printing (12 receipts per hour with sleep mode)
OLED		128 x 64 dots with Blue Backlight
MSR (Single Head) MSR model only	Format	ISO 7810, ISO 7811, ISO7812 1st, 2nd and 3rd Track/ JISII Track Reading
	Security	AES or 3DES encryption. DUKPT Key Management
Paper	Paper type	Thermal paper
	Paper width	$57.5 \pm 0.5\text{mm}$
	Paper thickness	$0.053\text{mm} \leq X \leq 0.12\text{mm}$
	Roll paper diameter	$13\text{mm} \leq \varnothing \leq 40.5\text{mm}$
	Recommended paper	P220AG, PD450, FD200, Alpha 400-2.1
Physical characteristics	Operation condition	0°C to 50°C, 20% to 85%RH
	Charging condition	0°C to 40°C, 0~10°C *1
	Storage condition	-20°C to 60°C, 5% to 95%RH
	Dimension	86(W) x 122.5(D) x 46(H) mm
	Weight	220g (including battery pack)
Reliability	TPH	50km(not more than 12.5% printing density)/100 million pulses
Software	Emulation	StarPRNT mode

*1. When the printer is used in a low temperature environment (less than 10 degrees), the battery's performance will be diminished, and the amount of time that you can use the printer for may be reduced.

 **WARNING:**

Pls. use the recommended thermal paper or same quality paper, otherwise it will influence the printing quality and decrease the thermal print head life.

Pls. Use at a room temperature if you want to set the print density to "Special".

Some types of the paper are not suitable for use in low-temperature environment.

■ Dimensions

- External Dimension: 86mm (W) x 122.5mm(D) x 46mm (H)
- Weight : 220g (including battery pack)
- Body color : Black

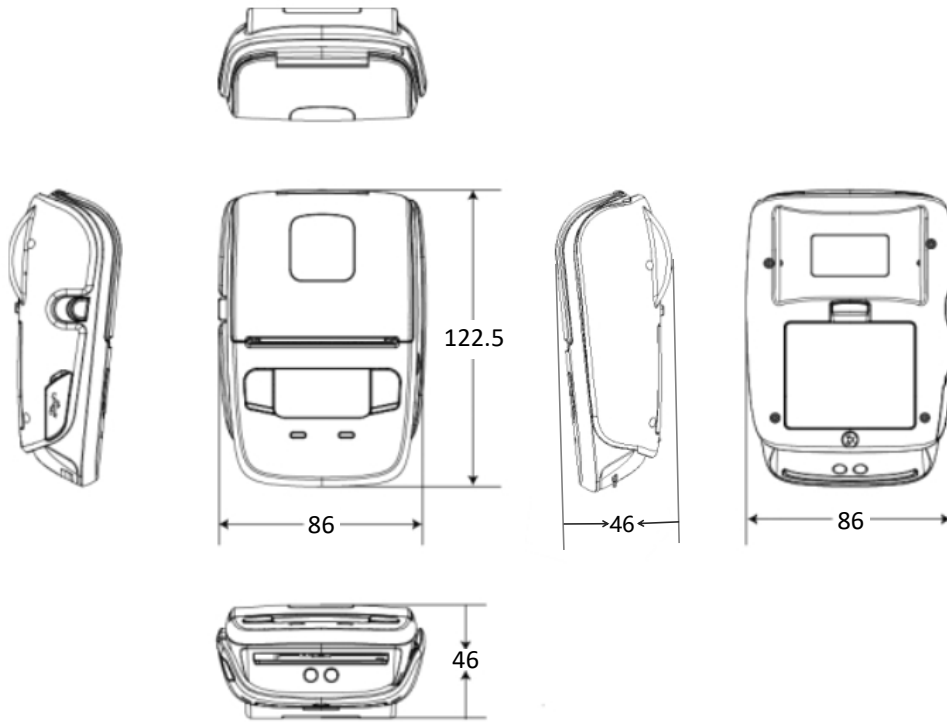

6. Detailed Specification

Item	Specification
Hardware specification	MCU: 32bits RISC, FLASH : 256K bytes, RAM: 48K bytes
Bluetooth highest frequencies	2.4 GHz
Bluetooth module basic clocking	26MHz
Bluetooth output	2.34mW (3.7dBm)

■ MSW Specification

The MSW settings are loaded when the power is turned On or when the printer is reset. If these settings are changed, they are made valid only after the printer is turned on or reset.

Flash memory has a limit life for writing data. Do not apply this command for every single receipt.

The following describes memory switch specifications

MSW0

bit	Function	OFF/"0"	ON/"1"	Note
F				
E				
D				
C				
B				
A				
9				
8				
7				
6				
5	SHIFT-JIS mode	Enable	Disable	
4	Destination	SBCS(1byte)	DBCS(2byte)	
3				
2				
1				
0				

MSW1

bit	Function	OFF/"0"	ON/"1"	Note
F				
E				
D				
C				
B				
A				
9				
8				
7				
6				
5				
4	Zero style	Normal	Slashed	
3	International Character	(Refer to below)		*1
2	International Character	(Refer to below)		*1
1	International Character	(Refer to below)		*1
0	International Character	(Refer to below)		*1

*1) International Character

n	MSW1-3	MSW1-2	MSW1-1	MSW1-0	International Character
"0"	0	0	0	0	USA
"1"	0	0	0	1	France
"2"	0	0	1	0	Germany
"3"	0	0	1	1	UK
"4"	0	1	0	0	Denmark 1
"5"	0	1	0	1	Sweden
"6"	0	1	1	0	Italy
"7"	0	1	1	1	Spain 1
"8"	1	0	0	0	Japan
"9"	1	0	0	1	Norway
"A"	1	0	1	0	Denmark 2
"B"	1	0	1	1	Spain 2
"C"	1	1	0	0	Latin America
"D"	1	1	0	1	Korea
"E"	1	1	1	0	Ireland
"F"	1	1	1	1	Legal

The international character setting for DBCS (Japan) is fixed at n = 8 (Japan).

The international character setting for DBCS (Korea) is fixed at n = 13 (Korea).

MSW2

bit	Function	OFF/"0"	ON/"1"	Note
F				
E				
D				
C				
B				
A				
9				
8				
7				
6				
5				
4				
3				
2	Print Density	(Refer to below)		*1
1	Print Density	(Refer to below)		*1
0	Print Density	(Refer to below)		*1

*1) Print Density

n	MSW2-2	MSW2-1	MSW2-0	Print Density
"0"	0	0	0	Medium Density
"1"	0	0	1	Low Density
"2"	0	1	0	High Density
"3"	0	1	1	Special Density

MSW3

bit	Function	OFF/ "0"	ON/"1"	Note
F	Code Page	(Refer to below)		*2
E	Code Page	(Refer to below)		*2
D	Code Page	(Refer to below)		*2
C	Code Page	(Refer to below)		*2
B	Code Page	(Refer to below)		*2
A	Code Page	(Refer to below)		*2
9	Code Page	(Refer to below)		*2
8	Code Page	(Refer to below)		*2
7				
6				
5	Kanji Character Spacing	(Refer to below)		*1
4	ANK Character Spacing	(Refer to below)		*1
3				
2				
1				
0	Line Spacing	4mm	3mm	

*1 Character Spacing

< SBCS >

MSW3-4	Character	Character Size (Font + Right Space)
0	ANK	12(12+0)dot
1	ANK	15(12+3)dot

< Japanese Kanji and DBCS >

MSW3-5	Character	Character Size (Left Space + Font + Right Space)
0	Full Size Kanji	26(1+24+1)dot
	Half Size Kanji	13(0+12+1)dot
1	Full Size Kanji	30(3+24+3)dot
	Half Size Kanji	15(1+12+2)dot

MSW3-4	Character	Character Size (Font + Right Space)
0	ANK	12(12+0)dot
1	ANK	15(12+3)dot

< Hangle or Chinese or Taiwan BIG5 and DBCS >

MSW3-5	Character	Character Size (Left Space + Font + Right Space)
0	Kanji	26(1+24+1)dot
1	Kanji	30(3+24+3)dot

MSW3-4	Character	Character Size (Font + Right Space)
0	ANK	13(12+1)dot
1	ANK	15(12+3)dot

*2) Code Page

n	MSW3-F	MSW3-E	MSW3-D	MSW3-C	MSW3-B	MSW3-A	MSW3-9	MSW3-8	Character Table
"00	0	0	0	0	0	0	0	0	Normal*
"01	0	0	0	0	0	0	0	1	CodePage437 (USA,Std. Europe)
"02	0	0	0	0	0	0	1	0	Katakana
"03	0	0	0	0	0	0	1	1	CodePage437 (USA,Std. Europe)
"04	0	0	0	0	0	1	0	0	Codepage 858 (Multilingual)
"05	0	0	0	0	0	1	0	1	Codepage 852 (Latin-2)
"06	0	0	0	0	0	1	1	0	Codepage 860 (Portuguese)
"07	0	0	0	0	0	1	1	1	Codepage 861 (Icelandic)
"08	0	0	0	0	1	0	0	0	Codepage 863 (Canadian French)
"09	0	0	0	0	1	0	0	1	Codepage 865 (Nordic)
"0A	0	0	0	0	1	0	1	0	Codepage 866 (Cyrillic Russian)
"0B	0	0	0	0	1	0	1	1	Codepage 855 (Cyrillic Bulgarian)
"0C	0	0	0	0	1	1	0	0	Codepage 857 (Turkey)
"0D	0	0	0	0	1	1	0	1	Codepage 862 (Israel (Hebrew))
"0E	0	0	0	0	1	1	1	0	Codepage 864 (Arabic)
"0F	0	0	0	0	1	1	1	1	Codepage 737 (Greek)
"10	0	0	0	1	0	0	0	0	Codepage 851 (Greek)
"11"	0	0	0	1	0	0	0	1	Codepage 869 (Greek)
"12	0	0	0	1	0	0	1	0	Codepage 928 (Greek)
"13	0	0	0	1	0	0	1	1	Codepage 772 (Lithuanian)
"14	0	0	0	1	0	1	0	0	Codepage 774 (Lithuanian)
"15	0	0	0	1	0	1	0	1	Codepage 874 (Thai)
"20	0	0	1	0	0	0	0	0	Codepage 1252 (Windows Latin-1)
"21	0	0	1	0	0	0	0	1	Codepage 1250 (Windows Latin-2)
"22	0	0	1	0	0	0	1	0	Codepage 1251 (Windows Cyrillic)
"40	0	1	0	0	0	0	0	0	Codepage 3840 (IBM-Russian)
"41	0	1	0	0	0	0	0	1	Codepage 3841 (Gost)
"42	0	1	0	0	0	0	1	0	Codepage 3843 (Polish)
"43	0	1	0	0	0	0	1	1	Codepage 3844 (CS2)
"44	0	1	0	0	0	1	0	0	Codepage 3845 (Hungarian)
"45	0	1	0	0	0	1	0	1	Codepage 3846 (Turkish)
"46	0	1	0	0	0	1	1	0	Codepage 3847 (Brazil-ABNT)
"47	0	1	0	0	0	1	1	1	Codepage 3848 (Brazil-ABICOMP)
"48	0	1	0	0	1	0	0	0	Codepage 1001 (Arabic)
"49	0	1	0	0	1	0	0	1	Codepage 2001 (Lithuanian-KBL)
"4A	0	1	0	0	1	0	1	0	Codepage 3001 (Estonian-1)

"4B	0	1	0	0	1	0	1	1	Codepage 3002 (Estonian-2)
"4C	0	1	0	0	1	1	0	0	Codepage 3011 (Latvian-1)
"4D	0	1	0	0	1	1	0	1	Codepage 3012 (Latvian-2)
"4E	0	1	0	0	1	1	1	0	Codepage 3021 (Bulgarian)
"4F	0	1	0	0	1	1	1	1	Codepage 3041 (Maltese)
"60	0	1	1	0	0	0	0	0	Thai Character Code 42 (Thai)
"61	0	1	1	0	0	0	0	1	Thai Character Code 11 (Thai)
"62	0	1	1	0	0	0	1	0	Thai Character Code 13 (Thai)
"63	0	1	1	0	0	0	1	1	Thai Character Code 14 (Thai)
"64	0	1	1	0	0	1	0	0	Thai Character Code 16 (Thai)
"65	0	1	1	0	0	1	0	1	Thai Character Code 17 (Thai)
"66	0	1	1	0	0	1	1	0	Thai Character Code 18 (Thai)
"FF	1	1	1	1	1	1	1	1	User Setting (Blank Code Page)

This function is valid when SBCS is selected.

MSW7

bit	Function	OFF/"0"	ON/"1"	Note
F				
E				
D				
C	ASB function	(Refer to below)		*2
B				
A				
9				
8	NSB function	(Refer to below)		*1
7				
6				
5				
4				
3				
2				
1				
0				

*1) NSB function

n	MSW7-8	USB	Bluetooth
"0"	0	Enable	Reserved
"1"	1	Disable	Reserved

*2) ASB function

n	MSW7-C	USB	Bluetooth
"0"	0	Enable	Disable
"1"	1	Disable	Enable

MSWB

bit	Function	OFF/"0"	ON/"1"	Note
F	Data timeout	Enable	Disable	*1
E				
D				
C				
B				
A				
9				
8				
7				
6				
5				
4				
3				
2				
1				
0				

*1) Data timeout

This function is valid only when using Buletooth I/F.

MSWL

bit	Function	OFF/"0"	ON/"1"	Note
F				
E				
D				
C				
B	Smart Power Option	Disable	Enable	
A				
9				
8				
7				
6				
5				
4				
3				
2				
1				
0				

MSWR

bit	Function	OFF/"0"	ON/"1"	Note
F				
E				
D				
C				
B				
A				
9				
8				
7				
6				
5				
4				
3				
2				
1	Paper Type	(Refer to below)		*1
0	Paper Type	(Refer to below)		*1

*1) Paper Type

n	MSWR-1	MSWR-0	Paper Type
"0"	0	0	Receipt
"1"	0	1	Black Mark (Front)
"2"	1	0	Black Mark (Back)

MSWS

bit	Function	OFF/"0"	ON/"1"	Note
F				*1
E				*1
D	Power Down	(Refer to below)		*1
C	Power Down	(Refer to below)		*1
B	Power Down	(Refer to below)		*1
A	Power Down	(Refer to below)		*1
9	Power Down	(Refer to below)		*1
8	Power Down	(Refer to below)		*1
7	Power Down	(Refer to below)		*1
6	Power Down	(Refer to below)		*1
5	Power Down	(Refer to below)		*1
4	Power Down	(Refer to below)		*1
3	Power Down	(Refer to below)		*1
2	Power Down	(Refer to below)		*1
1	Power Down	(Refer to below)		*1
0	Power Down	(Refer to below)		*1

*1) Power Down

MSWS														Power Down
D	C	B	A	9	8	7	6	5	4	3	2	1	0	
0	0	0	0	0	0	0	0	0	0	0	0	0	0	No use
0	0	0	0	0	0	0	0	0	0	0	0	0	1	1 Minute Power Off
0	0	0	0	0	0	0	0	0	0	0	0	1	0	2 Minute Power Off
0	0	0	0	0	0	0	0	0	0	0	0	1	1	3 Minute Power Off
0	0	0	0	0	0	0	0	0	0	0	1	0	0	4 Minute Power Off
0	0	0	0	0	0	0	0	0	0	0	1	0	1	5 Minute Power Off
0	0	0	0	0	0	0	0	0	0	0	1	1	0	6 Minute Power Off
0	0	0	0	0	0	0	0	0	0	0	1	1	1	7 Minute Power Off
0	0	0	0	0	0	0	0	0	0	1	0	0	0	8 Minute Power Off
.
.
.
.
1	0	0	1	1	1	0	0	0	0	1	1	1	1	9999 Minute Power Off

MSWT

bit	Function	OFF/"0"	ON/"1"	Note
F	Sleep Mode	(Refer to below)		*1
E	Sleep Mode	(Refer to below)		*1
D	Sleep Mode	(Refer to below)		*1
C	Sleep Mode	(Refer to below)		*1
B	Sleep Mode	(Refer to below)		*1
A	Sleep Mode	(Refer to below)		*1
9	Sleep Mode	(Refer to below)		*1
8	Sleep Mode	(Refer to below)		*1
7	Sleep Mode	(Refer to below)		*1
6	Sleep Mode	(Refer to below)		*1
5	Sleep Mode	(Refer to below)		*1
4	Sleep Mode	(Refer to below)		*1
3	Sleep Mode	(Refer to below)		*1
2	Sleep Mode	(Refer to below)		*1
1	Sleep Mode	(Refer to below)		*1
0	Sleep Mode	(Refer to below)		*1

*1) Sleep Mode

MSWT													Sleep Mode	
D	C	B	A	9	8	7	6	5	4	3	2	1		0
0	0	0	0	0	0	0	0	0	0	0	0	0	0	Unselectable
0	0	0	0	0	0	0	0	0	0	0	0	0	1	
0	0	0	0	0	0	0	0	0	0	0	0	1	0	
0	0	0	0	0	0	0	0	0	0	0	0	1	1	
0	0	0	0	0	0	0	0	0	0	0	1	0	0	
0	0	0	0	0	0	0	0	0	0	0	1	0	1	
0	0	0	0	0	0	0	0	0	0	0	1	1	0	
0	0	0	0	0	0	0	0	0	0	0	1	1	1	
0	0	0	0	0	0	0	0	0	0	1	0	0	0	
0	0	0	0	0	0	0	0	0	0	1	0	0	1	
0	0	0	0	0	0	0	0	0	0	1	0	1	0	10 Second Sleep
0	0	0	0	0	0	0	0	0	0	1	0	1	1	11 Second Sleep
0	0	0	0	0	0	0	0	0	0	1	1	0	0	12 Second Sleep
.
.
1	0	0	1	1	1	0	0	0	0	1	1	1	1	9999 Second Sleep

7. Interface

7.1 USB

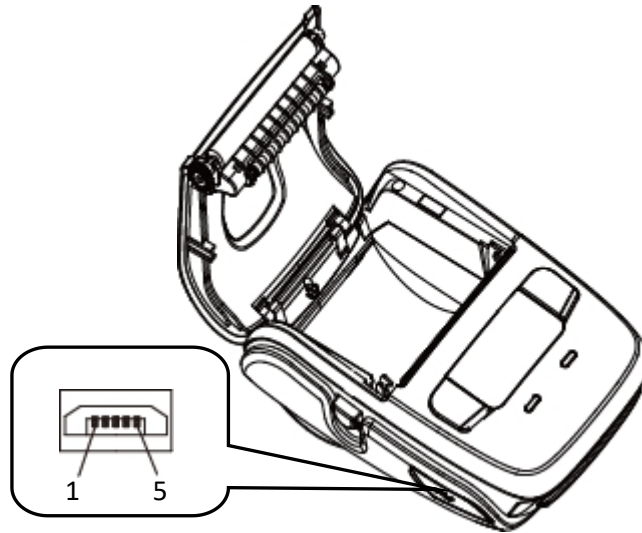

SM-L200 printer has a USB interface for Battery charging and is connected by means of 5pin micro USB socket. USB communication is only for the printer which “BT/USB” is displayed in the ID seal. In the following table, the signals present on the micro USB socket are listed.

Pin No.	SIGNAL
1	GND
2	NC
3	D+
4	D-
5	VBUS

■ USB cable

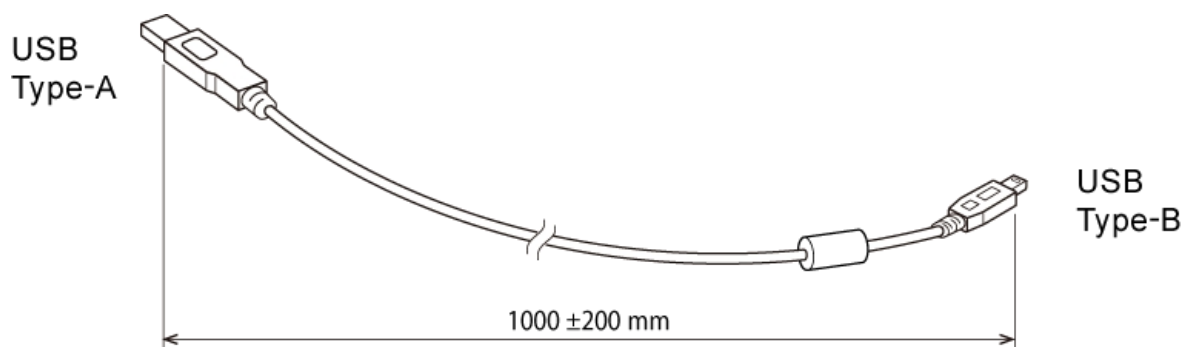

7.2 Bluetooth

Category	Specification
Bluetooth Spec.	Bluetooth Ver 3.0/4.0 [BLE] Dual Mode Class2 (10m)
Frequency Range	2.4GHz ISM band
Data Transmission Rate	115200bps adjustable
Data Bit	8 data bit fixed
Parity Bit	No parity fixed
Stop Bit	1 stop bit fixed

PIN code: 1234 as default for Android/Windows. (Bluetooth Ver.3.0)

Device Name: STAR L200-XXXXX

Device Name: STAR L204-XXXXX (MSR model)

(XXXXX is the last 5 digits of the Product Serial Number)

8. Specifications of Accessories

8.1 Battery Pack

3.7V, 1700mAh

Rechargeable Lithium-ion

Safety Approvals: PSE

8.2 Belt Clip

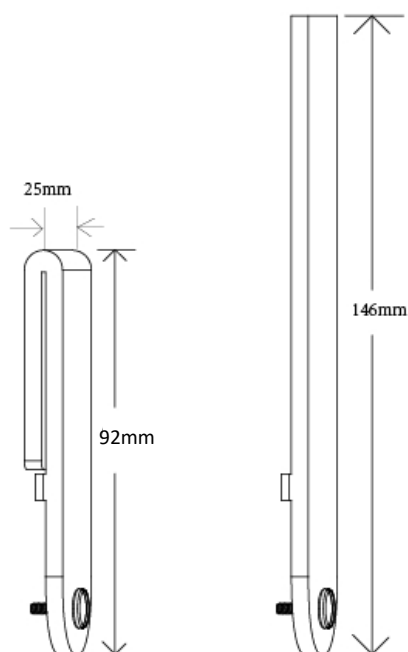

9. Troubleshooting Procedure

When a trouble occurs, confirm its phenomenon, locate a defective part in accordance with "9.1 Troubleshooting Guide", and troubleshoot as described below.

Phenomenon:

Find a trouble phenomenon in this column. If there are multiple phenomena, take all the corresponding items into consideration. This allows you to specify a hidden defective part.

Cause:

Lists as many possible causes as possible. Guess a trouble cause out of them and take its check method to specify the trouble cause.

Check Method:

Describes a check method to specify a trouble cause.

Remedy:

Troubleshoot by taking a remedy described in this column.

By troubleshooting in accordance with the above-mentioned procedure, you can troubleshoot efficiently with fewer misjudgments.

9.1 Troubleshooting Guide

9.1.1 Power Supply Failure

Phenomenon	Cause	Check Method	Remedy
No Power(Power Lamp not illuminated)	The battery is not connected		Connect the specified battery
	The battery is discharged	Battery level ≤3.3V	Charge the battery

9.1.2 Printing Failure

Phenomenon	Cause	Check Method	Remedy
No printing	The paper roll is loaded upside down.		Install the roll paper properly.
	Faulty Main Logic BD Unit.		Replace the Main Logic Board Unit..
	Faulty connection of the thermal head connector.	Check connection of the thermal head connector.	Connect the thermal head cable to connector properly.
	Faulty thermal head.		Replace the Mechanism Unit.
Partly not printed	Faulty connection of the thermal head connector.	Check connection of the thermal head connector.	Connect the thermal head cable to connector properly.
	Front cover one side close.		Close front cover correctly.
	Faulty thermal head.		Replace the Mechanism Unit.
Faint printout or uneven printout	Level of battery voltage is low.	Check the battery lamp on the OLED.	Charge the battery.
	Front cover one side close		Close front cover correctly
	Faulty thermal head.		Replace the Mechanism Unit.
	Foreign substance is adhered to the thermal head.	Check whether any foreign substance are adhered to the thermal head.	Dip a cotton swab or soft cloth in ethyl alcohol and wipe the foreign substance with them.
	Non-recommended paper is used.	Check whether the paper being used meets the specification.	Replace it with the specified paper.
	Faulty mounting of the platen.	Check mounting condition of the platen.	Mount the platen properly.

9.1.3 Faulty Sensor

Phenomenon	Cause	Check Method	Remedy
Does not detect presence of paper.	Faulty paper sensor.	Check whether the ERROR lamp flickers when paper is out.	Replace the Mechanism Unit.
	Foreign substance is attached the paper sensor.	Check whether any foreign substance are adhered to the paper sensor.	Remove the foreign substance.
	Faulty connection of the paper sensor connector.	Check connection of the paper sensor connector.	Connect the paper sensor cable to connector correctly.

9.1.4 Paper Feed Failure

Phenomenon	Cause	Check Method	Remedy
Paper is not fed or fed irregularly	The front cover is not closed properly.		Close the front cover properly.
	Faulty connection of the motor connector.	Check connection of the motor connector.	Connect the motor cable to connector correctly.
	Defective motor.		Replace the Mechanism Unit.
	Battery voltage drop.	Check the battery display of the OLED.	Charge the battery.
	Faulty Main Logic BD Unit.		Replace the Main Logic BD Unit.
	Faulty mounting of the platen.	Check mounting condition of the platen.	Mount the platen properly.
	Paper feed failure	Check whether or not the paper is jamming or torn and caught in the paper path.	Eliminate unnecessary paper in the paper path and set paper properly.
	Foreign substance in the gear.		Eliminate the foreign substance.
	Broken gear		If the gear is broken, replace the Mechanism Unit.

9.1.5 Error Message(Printer Status indication on the OLED)

Message	Description of failure message	Remark
Cover Open	Front cover is not closed properly.	Close front cover properly.
Out of Paper	Empty paper	Replace the paper roll.
High Temperature	Thermal Head is overheat.	Is recovered with the automatic which comes to be cool.

10. Fitting Regulations

10.1 Printer

EU	CE marking
	WEEE
JAPAN	Japanese Radio Law
	VCCI
USA	FCC
Canada	SEDC (IC)
MEXICO	NOM
AUSTRALIA	RCM
PHILIPINES	NTC

10.2 Battery Pack

JAPAN	PSE
	JBRC
EU	EU Battery Regulation
USA	RBRC

11. Revision History

Rev. No.	Date of Revision	Changes
Rev.1.0	July 2015	First Edition
---	---	Smart Power option
Rev.2.0	Mar. 2018	<ol style="list-style-type: none"> 1. USB communication 2. Change contents in paragraph 1 and paragraph 2; 3. Correct wrong spelling “at lease” to “at least”; 4. Add the comment on trademark; and some modifications of post formats. 5. Update the picture of printer, Safety Instruction Sheet and Easy Setup Guide in chapter 1.1; 6. Modify the component name in chapter 1.2; 7. Recover some previous contents in chapter 2.1.2; 8. Add the contents of chapter 2.2.1, chapter 2.2.2 and chapter 2.2.3; 9. Move previous chapter 2.4 “Memory Switch Settings” to chapter 3.3; 10. Update the self test page in Chapter 3.2.2
Rev.2.1	Jan. 2019	<ol style="list-style-type: none"> 1. Modify dimension: 86(W) x 122.5(D) x 46(H) mm 2. Change “FLASH:4M bytes, RAM:48K” to “FLASH:256K bytes, RAM:48K bytes” 3. Change “LCD” to “OLED” 4. Modify the table of “Remaining battery power” 5. Modify copy right: 2015-2019 6. Modify the self test sample 7. Modify the signal of USB
Rev.2.2	Jan. 2020	<ol style="list-style-type: none"> 1. Delete the information of firmware version after “Table of Contents” 2. Delete the information of firmware version in “Revision History”
Rev.2.3	Apr. 2020	<ol style="list-style-type: none"> 1. Add “Safety Instruction Sheet For Battery Pack” to “1.1 Printer & Accessories”(P2) 2. Add the sentence to “Charging the Battery Pack” (P7)
Rev.2.4	May. 2021	<ol style="list-style-type: none"> 1. Modify “4.2 Recommended Paper” (P29)
Rev.2.5	Oct. 2021	<ol style="list-style-type: none"> 1. Update URLs which links to CE Doc, UK Doc and FCC IC statement

Rev. No.	Date of Revision	Changes
Rev.2.5	Nov. 2021	1. Add "Radio Equipment Information"
Rev.2.6	Jan.2022	1. Add explanation on change related to charging control to 2.1.2 (P6) 2. Modify a table for recommendation paper in 4.2 (P29)



<http://www.starmicronics.com/support/>

Rev.2.5