

Yulong Computer
Telecommunication Scientific
(Shenzhen) Co., Ltd

TEST REPORT

SCOPE OF WORK

FCC TESTING– MODEL: CP3503L

REPORT NUMBER

200810035SZN-001

ISSUE DATE

September 10, 2020

PAGES

33

DOCUMENT CONTROL NUMBER

FCC ID 22/24/27/90_a

© 2017 INTERTEK



FCC RF Test Report

For

Yulong Computer Telecommunication Scientific (Shenzhen) Co., Ltd

Product Name: Smartphone

Model Number: CP3503L

FCC ID: R38YLCP3503L

Report No: 200810035SZN-001

Tested and Prepared by:

Approved by:

Leo Li
Project Engineer

Peter Kang
Senior Technical Supervisor
Date: September 10, 2020

This report is for the exclusive use of Intertek's Client and is provided pursuant to the agreement between Intertek and its Client. Intertek's responsibility and liability are limited to the terms and conditions of the agreement. Intertek assumes no liability to any party, other than to the Client in accordance with the agreement, for any loss, expense or damage occasioned by the use of this report. Only the Client is authorized to permit copying or distribution of this report and then only in its entirety. Any use of the Intertek name or one of its marks for the sale or advertisement of the tested material, product or service must first be approved in writing by Intertek. The observations and test results in this report are relevant only to the sample tested. This report by itself does not imply that the material, product, or service is or has ever been under an Intertek certification program.

Intertek Testing Service Shenzhen Ltd. Longhua Branch

101, 201, Building B, No. 308 Wuhe Avenue, Zhangkengjing Community GuanHu Subdistrict, LongHua District, Shenzhen, People's Republic of China

Tel: (86 755) 8601 6288 Fax: (86 755) 8601 6751

Table of Contents

1.0 Summary of Test Result	3
1.1 Cellular Band (824-849MHz paired with 869-894MHz).....	4
1.2 PCS Band (1850-1910MHz paired with 1930-1990MHz)	5
1.3 AWS Band (1710-1755MHz paired with 2110-2155MHz).....	6
1.4 BRS&EBS Band (2500-2570 MHz paired with 2620-2690 MHz)	7
1.5 Band12 (699-716MHz paired with 729-746 MHz)	8
1.6 Band13 (777-787MHz paired with 746-756 MHz)	9
1.6 Band17 (704-716MHz paired with 734-746 MHz)	10
2.0 General Description	11
2.1 Product Description	11
2.2 Test Facility	11
2.3 Test Environment Condition	11
2.4 Sub-Assembly	11
2.5 Technical Specification	12
3.0 General Test Conditions/Configuration	15
3.1 Test Modes	15
3.2 Test Environment	15
3.3 Test Frequency	15
4.0 Description of Tests	22
4.1 Radiated Power and Radiated Spurious	22
4.2 Peak-Average Ratio	23
4.3 Occupied Bandwidth	24
4.4 Band Edge Compliance.....	25
4.5 Spurious and Harmonic Emissions at Antenna Terminal.....	26
4.6 Frequency Stability / Temperature Variation	27
5.0 Test Setups	28
5.1 Test Setup 1.....	28
5.2 Test Setup 2.....	28
5.3 Test Setup 3.....	29
6.0 General Description	32
7.0 Measurement Uncertainty	33
8.0 Appendixes	33

1.0 Summary of Test Result

Applicant:	Yulong Computer Telecommunication Scientific (Shenzhen) Co., Ltd
Address:	Building B, Boton Science Part Chaguang Road, Xili Town, Nanshan District Shenzhen, China
Product name:	Smartphone
Model Number:	CP3503L
FCC ID:	R38YLCP3503L
Report number:	200810035SZN-001
Date of Test	10 August 2020 to 9 September 2020

The above equipment was tested by Intertek Testing Services Shenzhen Ltd. Longhua Branch. The test data, data evaluation, test procedures, and equipment configurations shown in this report were made in accordance with the procedures given in ANSI 63.26:2015 and KDB 971168 D01. This device is in compliance with FCC rules as following:

47 CFR FCC Part 02:2019
47 CFR FCC Part 22:2019
47 CFR FCC Part 24:2019
47 CFR FCC Part 27:2019
47 CFR FCC Part 90:2019

The test results of this report relate only to the tested sample identified in this report.

1.1 Cellular Band (824-849MHz paired with 869-894MHz)

Test Item	FCC Rule No.	Requirements	Test Result	Verdict (Note1)
Effective (Isotropic) Radiated Power Output Data	§2.1046, §2.913	FCC: ERP ≤ 7 W.	Appendix A	Pass
Peak-Average Ratio	--	--	Appendix B	Pass
Modulation Characteristics	§2.1047	Digital modulation	Appendix C	Pass
Bandwidth	§2.1049	OBW: No limit. EBW: No limit.	Appendix D	Pass
Band Edges Compliance	§2.1051, §2.917	≤ -13 dBm/1%*EBW, in 1 MHz bands immediately outside and adjacent to the frequency block.	Appendix E	Pass
Spurious Emission at Antenna Terminals	§2.1051, §2.917	FCC: ≤ -13 dBm/100 kHz, from 9 kHz to 10 th harmonics but outside authorized operating frequency ranges.	Appendix F	Pass
Field Strength of Spurious Radiation	§2.1053, §2.917	FCC: ≤ -13 dBm/100 kHz.	Appendix G	Pass
Frequency Stability	§2.1055, §2.355	≤ ±2.5ppm.	Appendix H	Pass
NOTE 1: For the verdict, the "N/A" denotes "not applicable", the "N/T" denotes "not tested".				

1.2 PCS Band (1850-1910MHz paired with 1930-1990MHz)

Test Item	FCC Rule No.	Requirements	Test Result	Verdict (Note1)
Effective (Isotropic) Radiated Power Output Data	§2.1046, §4.232	EIRP ≤ 2 W	Appendix A	Pass
Peak-Average Ratio	§2.1046, §4.232	Limit≤13 dB	Appendix B	Pass
Modulation Characteristics	§2.1047	Digital modulation	Appendix C	Pass
Bandwidth	§2.1049	OBW: No limit. EBW: No limit.	Appendix D	Pass
Band Edges Compliance	§2.1051, §4.238	≤ -13 dBm/1%*EBW, in 1 MHz bands immediately outside and adjacent to the frequency block.	Appendix E	Pass
Spurious Emission at Antenna Terminals	§2.1051, §4.238	≤ -13 dBm/1 MHz, from 9 kHz to 10 th harmonics but outside authorized operating frequency ranges.	Appendix F	Pass
Field Strength of Spurious Radiation	§2.1053, §4.238	≤ -13 dBm/1 MHz.	Appendix G	Pass
Frequency Stability	§2.1055, §4.235	≤ ±2.5 ppm.	Appendix H	Pass
NOTE 1: For the verdict, the "N/A" denotes "not applicable", the "N/T" denotes "not tested".				

1.3 AWS Band (1710-1755MHz paired with 2110-2155MHz)

Test Item	FCC Rule No.	Requirements	Test Result	Verdict (Note1)
Effective (Isotropic) Radiated Power Output Data	§2.1046, §7.50(d)	EIRP ≤ 1 W	Appendix A	Pass
Peak-Average Ratio	§2.1046, §7.50(d)	Limit ≤ 13 dB	Appendix B	Pass
Modulation Characteristics	§2.1047	Digital modulation	Appendix C	Pass
Bandwidth	§2.1049	OBW: No limit. EBW: No limit.	Appendix D	Pass
Band Edges Compliance	§2.1051, §7.53(h)	≤ -13 dBm/1%*EBW, in 1 MHz bands immediately outside and adjacent to the frequency block.	Appendix E	Pass
Spurious Emission at Antenna Terminals	§2.1051, §7.53(h)	≤ -13 dBm/1 MHz, from 9 kHz to 10 th harmonics but outside authorized operating frequency ranges.	Appendix F	Pass
Field Strength of Spurious Radiation	§2.1053, §7.53(h)	≤ -13 dBm/1 MHz.	Appendix G	Pass
Frequency Stability	§2.1055, §7.54	≤ ±2.5 ppm.	Appendix H	Pass
NOTE 1: For the verdict, the "N/A" denotes "not applicable", the "N/T" denotes "not tested".				

1.4 BRS&EBS Band (2500-2570 MHz paired with 2620-2690 MHz)

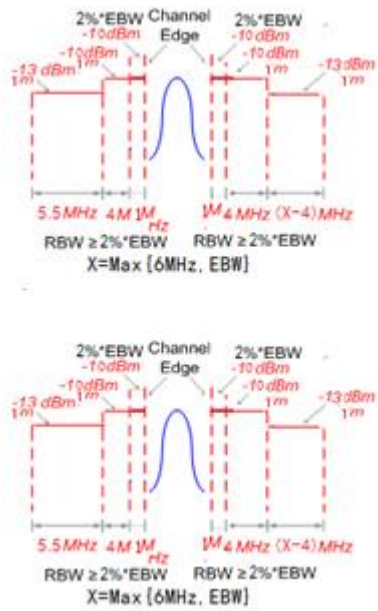
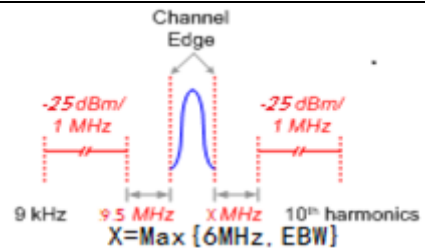
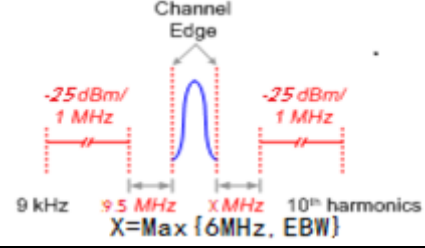
Test Item	FCC Rule No.	Requirements	Test Result	Verdict (Note 1)
Effective (Isotropic) Radiated Power Output Data	§2.1046, §27.50(h)	EIRP ≤ 2W	Appendix A	Pass
Peak-Average Ratio	§27.50(a)	Limit ≤ 13 dB	Appendix B	Pass
Modulation Characteristics	§2.1047	Digital modulation	Appendix C	Pass
Bandwidth	§2.1049	OBW: No limit. EBW: No limit.	Appendix D	Pass
Band Edges Compliance	§2.1051, §27.53(m4)	FCC/IC: 	Appendix E	Pass
Spurious Emission at Antenna Terminals	§2.1051, §27.53(m)		Appendix F	Pass
Field Strength of Spurious Radiation	§2.1053, §27.53(m)		Appendix G	Pass
Frequency Stability	§2.1055, §27.54	Within authorized bands of operation/frequency block.	Appendix H	Pass
NOTE 1: For the verdict, the "N/A" denotes "not applicable", the "NIT" denotes "not tested".				

1.5 Band12 (699-716MHz paired with 729-746 MHz)

Test Item	FCC Rule No	Requirements	Test Result	Verdict (Note1)
Effective (Isotropic) Radiated Power Output Data	§27.50(c)	FCC: ERP ≤ 3 W.	Appendix A	Pass
Peak-Average Ratio	--	--	Appendix B	Pass
Modulation Characteristics	§2.1047	Digital modulation	Appendix C	Pass
Bandwidth	§2.1047	OBW: No limit. EBW: No limit.	Appendix D	Pass
Band Edges Compliance	§2.1049,	≤ -13 dBm/1%*EBW, in 1 MHz bands immediately outside and adjacent to the frequency block.	Appendix E	Pass
Spurious Emission at Antenna Terminals	§2.1051, §27.53(g)	FCC: ≤ -13 dBm/100 kHz, from 9 kHz to 10 th harmonics but outside authorized operating frequency ranges.	Appendix F	Pass
Field Strength of Spurious Radiation	§2.1051, §27.53(g)	FCC: ≤ -13 dBm/100 kHz.	Appendix G	Pass
Frequency Stability	§2.1053, §27.53(g)	≤ ±2.5ppm.	Appendix H	Pass
NOTE 1: For the verdict, the "N/A" denotes "not applicable", the "N/T" denotes "not tested".				

1.6 Band13 (777-787MHz paired with 746-756 MHz)

Test Item	FCC Rule No	Requirements	Test Result	Verdict (Note1)
Effective (Isotropic) Radiated Power Output Data	§27.50(c)	FCC: ERP ≤ 3 W.	Appendix A	Pass
Peak-Average Ratio	--	--	Appendix B	Pass
Modulation Characteristics	§2.1047	Digital modulation	Appendix C	Pass
Bandwidth	§2.1047	OBW: No limit. EBW: No limit.	Appendix D	Pass
Band Edges Compliance	§2.1049,	≤ -13 dBm/1%*EBW, in 1 MHz bands immediately outside and adjacent to the frequency block.	Appendix E	Pass
Spurious Emission at Antenna Terminals	§2.1051, §27.53(g)	FCC: ≤ -13 dBm/100 kHz, from 9 kHz to 10 th harmonics but outside authorized operating frequency ranges.	Appendix F	Pass
Field Strength of Spurious Radiation	§2.1051, §27.53(g)	FCC: ≤ -13 dBm/100 kHz.	Appendix G	Pass
Frequency Stability	§2.1053, §27.53(g)	≤ ±2.5ppm.	Appendix H	Pass
NOTE 1: For the verdict, the "N/A" denotes "not applicable", the "N/T" denotes "not tested".				

1.7 Band17 (704-716MHz paired with 734-746 MHz)

Test Item	FCC Rule No.	Requirements	Test Result	Verdict (Note1)
Effective (Isotropic) Radiated Power Output Data	§2.750(c).	FCC: ERP ≤ 3 W.	Appendix A	Pass
Peak-Average Ratio	--	--	Appendix B	Pass
Modulation Characteristics	§2.1047	Digital modulation	Appendix C	Pass
Bandwidth	§2.1047	OBW: No limit. EBW: No limit.	Appendix D	Pass
Band Edges Compliance	§2.1049,	≤ -13 dBm/1%*EBW, in 1 MHz bands immediately outside and adjacent to the frequency block.	Appendix E	Pass
Spurious Emission at Antenna Terminals	§2.1051, §2.753(g)	FCC: ≤ -13 dBm/100 kHz, from 9 kHz to 10 th harmonics but outside authorized operating frequency ranges.	Appendix F	Pass
Field Strength of Spurious Radiation	§2.1051, §2.753(g)	FCC: ≤ -13 dBm/100 kHz.	Appendix G	Pass
Frequency Stability	§2.1053, §2.753(g)	≤ ±2.5ppm.	Appendix H	Pass
NOTE 1: For the verdict, the "N/A" denotes "not applicable", the "N/T" denotes "not tested".				

2.0 General Description

2.1 Product Description

CP3503L is subscriber equipment in the GSM/UMTS/LTE system. The GSM frequency band includes GSM850 and DCS1800 and PCS1900. but only GSM850/1900 test data included in this report. The UMTS frequency band is band I and band II and band IV and band V, but only band II and Band IV and Band V test data included in this report. The LTE frequency band is Band I and Band II and band III band IV and band V and band VII and Band XII and Band XIII and Band XVII and Band XXVIII, but only Band II and band IV and band V and band VII and Band XII and Band XIII and Band XVII test data included in this report. The Mobile Phone implements such functions as RF signal receiving/transmitting, LTE/UMTS and GSM/GPRS/EDGE protocol processing, voice, video MMS service, GPS, Bluetooth and Wi-Fi etc. Externally it provides micro SD card interface, earphone port (to provide voice service) and USIM card interface. It also provides Bluetooth module to synchronize data between a PC and the phone, or to use the built-in modem of the phone to access the Internet with a PC, or to exchange data with other Bluetooth devices. The EUT is powered by AC 120V/60Hz. For more detailed features description, please refer to the user's manual.

2.2 Test Facility

Company Name:	Intertek Testing Service Shenzhen Ltd. Longhua Branch
Address:	101, 201, Building B, No. 308 Wuhe Avenue, Zhangkengjing Community, GuanHu Subdistrict, LongHua District, ShenZhen, P.R. China.
FCC Registration Number:	CN1188

2.3 Test Environment Condition

Ambient Temperature:	19.5 to 25 °C
Ambient Relative Humidity:	40 to 55 %
Atmospheric Pressure:	Not applicable

2.4 Sub-Assembly

Description	Manufacturer	Description
Power Adapter	SHENZHEN TIANYIN ELECTRONICS CO., LTD	Model: TPA-46050200UU Input: 100-240V~, 50/60Hz, 0.3A Output: DC 5V, 2000mA
USB cable	Provided by applicant	Shielded, Length: 75cm

2.5 Technical Specification

Characteristics	Description	
Radio System Type	GSM UMTS LTE	
Supported Frequency Range	GSM850/ WCDMA850	Transmission (TX): 824 to 849 MHz
		Receiving (RX): 869 to 894 MHz
	GSM1900/ WCDMA1900	Transmission (TX): 1850 to 1910 MHz
		Receiving (RX): 1930 to 1990 MHz
	WCDMA1700	Transmission (TX): 1710 to 1755 MHz
		Receiving (RX): 2110 to 2155 MHz
	LTE BAND2	Transmission (TX): 1850 to 1910 MHz
		Receiving (RX): 1930 to 1990 MHz
	LTE BAND4	Transmission (TX): 1710 to 1755 MHz
		Receiving (RX): 2110 to 2155 MHz
	LTE BAND5	Transmission (TX): 824 to 849 MHz
		Receiving (RX): 869 to 894 MHz
	LTE BAND7	Transmission (TX): 2500 to 2570 MHz
		Receiving (RX): 2620 to 2690 MHz
	LTE BAND12	Transmission (TX): 699 to 716 MHz
		Receiving (RX): 729 to 746 MHz
	LTE BAND13	Transmission (TX): 777 to 787 MHz
		Receiving (RX): 746 to 756 MHz
LTE BAND17	Transmission (TX): 704 to 716 MHz	
	Receiving (RX): 734 to 746 MHz	
TX and RX Antenna Ports	TX & RX port:	1
	TX-only port:	0
	RX-only port:	1
Target TX Output Power	GSM850: 32.5dBm GSM1900: 31.5dBm UMTS850: 24.5dBm UMTS1900: 24dBm UMTS1700: 24dBm LTE BAND2: 24dBm LTE BAND4: 23.5dBm LTE BAND5: 24dBm LTE BAND7: 23dBm LTE BAND12: 23.5dBm LTE BAND13: 23.5dBm LTE BAND17: 23.5dBm	

Antenna Gain:	GSM850: -2.1dBm GSM1900: -0.4dBm UMTS850: -0.4dBm UMTS1900: -0.6dBm UMTS1700: -2.0dBm LTE BAND2: -0.4dBm LTE BAND4: -0.6dBm LTE BAND5: -2.0dBm LTE BAND7: 0.2dBm LTE BAND12: -2.4dBm LTE BAND13: -2.1dBm LTE BAND17: -2.5dBm	
Supported Channel Bandwidth	GSM system:	200 kHz
	UMTS system:	5 MHz
	LTE band 2	1.4 MHz, 3 MHz, 5 MHz, 10 MHz, 15 MHz, 20 MHz
	LTE band 4	1.4 MHz, 3 MHz, 5 MHz, 10 MHz, 15 MHz, 20 MHz
	LTE band 5	1.4 MHz, 3 MHz, 5 MHz, 10 MHz
	LTE band 7	5MHz, 10MHz, 15MHz, 20MHz
	LTE band 12	1.4 MHz, 3 MHz, 5 MHz, 10 MHz
	LTE band 13	5 MHz, 10 MHz
	LTE band 17	5 MHz, 10 MHz
Designation of Emissions (Note: the necessary bandwidth of which is the worst value from the measured occupied bandwidths for each type of channel bandwidth configuration.)	GSM850:	246KGXW, 245KG7W
	GSM1900:	247KGXW, 246KG7W
	UMTS1900:	4M17F9W
	UMTS1700:	4M16F9W
	UMTS850:	4M17F9W
	LTE BAND2:	1M09G7D (1.4 MHz QPSK modulation), 1M09W7D (1.4 MHz 16QAM modulation) 2M71G7D (3 MHz QPSK modulation), 2M70W7D (3 MHz 16QAM modulation) 4M50G7D (5 MHz QPSK modulation), 4M51W7D (5 MHz 16QAM modulation) 8M99G7D (10 MHz QPSK modulation), 8M99W7D (10 MHz 16QAM modulation) 13M48G7D (15 MHz QPSK modulation), 13M48W7D (15 MHz 16QAM modulation) 18M04G7D (20 MHz QPSK modulation), 18M04W7D (20 MHz 16QAM modulation)

LTE BAND4:	1M09G7D (1.4 MHz QPSK modulation), 1M09W7D (1.4 MHz 16QAM modulation) 2M70G7D (3 MHz QPSK modulation), 2M70W7D (3 MHz 16QAM modulation) 4M50G7D (5 MHz QPSK modulation), 4M51W7D (5 MHz 16QAM modulation) 8M99G7D (10 MHz QPSK modulation), 8M99W7D (10 MHz 16QAM modulation) 13M48G7D (15 MHz QPSK modulation), 13M48W7D (15 MHz 16QAM modulation) 18M10G7D (20 MHz QPSK modulation), 18M10W7D (20 MHz 16QAM modulation)
LTE BAND5:	1M09G7D (1.4 MHz QPSK modulation), 1M09W7D (1.4 MHz 16QAM modulation) 2M71G7D (3 MHz QPSK modulation), 2M70W7D (3 MHz 16QAM modulation) 4M51G7D (5 MHz QPSK modulation), 4M52W7D (5 MHz 16QAM modulation) 8M99G7D (10 MHz QPSK modulation), 8M99W7D (10 MHz 16QAM modulation)
LTE BAND7:	4M50G7D (5 MHz QPSK modulation), 4M50W7D (5 MHz 16QAM modulation) 8M99G7D (10 MHz QPSK modulation), 8M99W7D (10 MHz 16QAM modulation) 13M48G7D (15 MHz QPSK modulation), 13M48W7D (15 MHz 16QAM modulation) 18M04G7D (20 MHz QPSK modulation), 18M04W7D (20 MHz 16QAM modulation)
LTE BAND12:	1M09G7D (1.4 MHz QPSK modulation), 1M09W7D (1.4 MHz 16QAM modulation) 2M70G7D (3 MHz QPSK modulation), 2M70W7D (3 MHz 16QAM modulation) 4M50G7D (5 MHz QPSK modulation), 4M50W7D (5 MHz 16QAM modulation) 8M99G7D (10 MHz QPSK modulation), 8M99W7D (10 MHz 16QAM modulation)
LTE BAND13:	4M50G7D (5 MHz QPSK modulation), 4M51W7D (5 MHz 16QAM modulation) 8M99G7D (10 MHz QPSK modulation), 8M99W7D (10 MHz 16QAM modulation)
LTE BAND17:	4M50G7D (5 MHz QPSK modulation), 4M51W7D (5 MHz 16QAM modulation) 8M99G7D (10 MHz QPSK modulation), 8M99W7D (10 MHz 16QAM modulation)

3.0 General Test Conditions/Configuration

3.1 Test Modes

Test Mode	Test Modes Description
GSM/TM1	GSM system, GSM/GPRS, GMSK modulation
GSM/TM2	GSM system, EDGE, 8PSK modulation
UMTS/TM1	WCDMA system, QPSK modulation
UMTS/TM2	HSDPA system, QPSK modulation
UMTS/TM3	HSUPA system, QPSK modulation
LTE/TM1	LTE system, QPSK modulation
LTE/TM2	LTE system, 16QAM modulation

3.2 Test Environment

Environment Parameter	Selected Values During Tests	
Relative Humidity	Ambient	
Temperature	TN	Ambient
Voltage	VL	3.6V
	VN	3.8V
	VH	4.35V

NOTE: VL= lower extreme test voltage
 VN= nominal voltage
 VH= upper extreme test voltage
 TN= normal temperature

3.3 Test Frequency

Test Mode	TX / RX	RF Channel		
		Low (L)	Middle (M)	High (H)
GSM850	TX	Channel 128	Channel 190	Channel 251
		824.2MHz	836.6MHz	848.8MHz
	RX	Channel 128	Channel 190	Channel 251
		869.2MHz	881.6MHz	893.8MHz
WCDMA850	TX	Channel 4132	Channel 4182	Channel 4233
		826.4MHz	836.4MHz	846.6MHz
	RX	Channel 4357	Channel 4407	Channel 4458
		871.4MHz	881.4MHz	891.6MHz

Test Mode	TX / RX	RF Channel			
		Low (L)	Middle (M)	High (H)	
GSM1900	TX	Channel 512	Channel 661	Channel 810	
		1850.2MHz	1880.0MHz	1909.8MHz	
	RX	Channel 512	Channel 661	Channel 810	
		1930.2 MHz	1960.0 MHz	1989.8 MHz	
WCDMA1900	TX	Channel 9262	Channel9400	Channel9538	
		1852.4MHz	1880.0MHz	1907.6MHz	
	RX	Channel 9662	Channel 9800	Channel 9938	
		1932.4 MHz	1960.0 MHz	1987.6 MHz	
Test Mode	TX / RX	RF Channel			
		Low (L)	Middle (M)	High (H)	
WCDMA1700	TX	Channel1312	Channel1413	Channel1513	
		1712.4MHz	1732.6MHz	1752.6MHz	
	RX	Channel 1537	Channel 1638	Channel 1738	
		2112.4 MHz	2132.6 MHz	2152.6 MHz	
Test Mode	TX / RX	RF Channel			
		Low (B)	Middle (M)	High (T)	
	TX(1.4M)	Channel 18607	Channel 18900	Channel 19193	
		1850.7 MHz	1880 MHz	1909.3 MHz	
	TX(3M)	Channel 18615	Channel 18900	Channel 19185	
		1851.5 MHz	1880 MHz	1908.5 MHz	
	TX(5M)	Channel 18625	Channel 18900	Channel 19175	
		1852.5 MHz	1880 MHz	1907.5 MHz	
	TX(10M)	Channel 18650	Channel 18900	Channel 19150	
		1855 MHz	1880 MHz	1905 MHz	
			Channel 18675	Channel 18900	Channel 19125

LTE Band 2	TX(15M)	1857.5 MHz	1880 MHz	1902.5 MHz
	TX(20M)	Channel 18700	Channel 18900	Channel 19100
		1860 MHz	1880 MHz	1900 MHz
	RX(1.4M)	Channel 607	Channel 900	Channel 1193
		1930.7 MHz	1960 MHz	1989.3 MHz
	RX(3M)	Channel 615	Channel 900	Channel 1185
		1931.5 MHz	1960 MHz	1988.5 MHz
	RX(5M)	Channel 625	Channel 900	Channel 1175
		1932.5 MHz	1960 MHz	1987.5 MHz
	RX(10M)	Channel 650	Channel 900	Channel 1150
		1935 MHz	1960 MHz	1985 MHz
	RX(15M)	Channel 675	Channel 900	Channel 1125
		1937.5 MHz	1960 MHz	1982.5 MHz
	RX(20M)	Channel 700	Channel 900	Channel 1100
1940 MHz		1960 MHz	1980 MHz	
Test Mode	TX / RX	RF Channel		
		Low (B)	Middle (M)	High (T)
LTE Band 4	TX(1.4M)	Channel 19957	Channel 20175	Channel 20393
		1710.7 MHz	1732.5 MHz	1754.3 MHz
	TX(3M)	Channel 19965	Channel 20175	Channel 20385
		1711.5 MHz	1732.5 MHz	1753.5 MHz
	TX(5M)	Channel 19975	Channel 20175	Channel 20375
		1712.5 MHz	1732.5 MHz	1752.5 MHz
	TX(10M)	Channel 20000	Channel 20175	Channel 20350
		1715 MHz	1732.5 MHz	1750 MHz
	TX(15M)	Channel 20025	Channel 20175	Channel 20325
		1717.5 MHz	1732.5 MHz	1747.5 MHz

	TX(20M)	Channel 20050	Channel 20175	Channel 20300
		1720 MHz	1732.5 MHz	1745 MHz
	RX(1.4M)	Channel 1975	Channel 2175	Channel 2375
		2112.5 MHz	2132.5MHz	2152.5 MHz
	RX(3M)	Channel 2000	Channel 2175	Channel 2350
		2115 MHz	2132.5MHz	2150 MHz
	RX(5M)	Channel 1975	Channel 2175	Channel 2375
		2112.5 MHz	2132.5MHz	2152.5 MHz
	RX(10M)	Channel 2000	Channel 2175	Channel 2350
		2115 MHz	2132.5MHz	2150 MHz
	RX(15M)	Channel 2025	Channel 2175	Channel 2325
		2117.5 MHz	2132.5MHz	2147.5 MHz
	RX(20M)	Channel 2050	Channel 2175	Channel 2300
		2120 MHz	2132.5MHz	2145 MHz
Test Mode	TX / RX	RF Channel		
		Low (B)	Middle (M)	High (T)
LTE Band 5	TX(1.4M)	Channel 20407	Channel 20525	Channel 20643
		824.7 MHz	836.5 MHz	848.3 MHz
	TX(3M)	Channel 20415	Channel 20525	Channel 20635
		825.5 MHz	836.5 MHz	847.5 MHz
	TX(5M)	Channel 20425	Channel 20525	Channel 20625
		826.5 MHz	836.5 MHz	846.5 MHz
	TX(10M)	Channel 20450	Channel 20525	Channel 20600
		829 MHz	836.5 MHz	844 MHz
	RX(1.4M)	Channel 2407	Channel 2525	Channel 2643
		869.7 MHz	881.5 MHz	893.3 MHz
		Channel 2415	Channel 2525	Channel 2635

	RX (3M)	870.5 MHz	881.5 MHz	892.5 MHz
	RX(5M)	Channel 2425	Channel 2525	Channel 2625
		871.5 MHz	881.5 MHz	891.5 MHz
	RX (10M)	Channel 2450	Channel 2525	Channel 2600
		874 MHz	881.5 MHz	889 MHz
Test Mode	TX / RX	RF Channel		
		Low (B)	Middle (M)	High (T)
LTE Band 7	TX (5M)	Channel 20775	Channel 21100	Channel 21425
		2502.5 MHz	2535 MHz	2567.5 MHz
	TX (10M)	Channel 20800	Channel 21100	Channel 21400
		2505 MHz	2535 MHz	2565 MHz
	TX (15M)	Channel 20825	Channel 21100	Channel 21375
		2507.5 MHz	2535 MHz	2562.5 MHz
	TX (20M)	Channel 20850	Channel 21100	Channel 21350
		2510 MHz	2535 MHz	2560 MHz
	RX (5M)	Channel 2775	Channel 3100	Channel 3425
		2622.5 MHz	2655 MHz	2687.5 MHz
	RX (10M)	Channel 2800	Channel 3100	Channel 3400
		2625 MHz	2655 MHz	2685 MHz
	RX (15M)	Channel 2825	Channel 3100	Channel 3375
		2627.5 MHz	2655 MHz	2682.5 MHz
RX (20M)	Channel 2850	Channel 3100	Channel 3350	
	2630 MHz	2655 MHz	2680 MHz	
Test Mode	TX / RX	RF Channel		
		Low (B)	Middle (M)	High (T)
	TX(1.4M)	Channel 23017	Channel 23095	Channel 23173
		699.7 MHz	707.5 MHz	715.3 MHz

LTE Band 12	TX(3M)	Channel 23025	Channel 23095	Channel 23165
		700.5 MHz	707.5 MHz	714.5 MHz
	TX(5M)	Channel 23035	Channel 23095	Channel 23155
		701.5 MHz	707.5 MHz	713.5 MHz
	TX(10M)	Channel 23060	Channel 23095	Channel 23130
		704 MHz	707.5 MHz	711 MHz
	RX(1.4M)	Channel 5017	Channel 5095	Channel 5173
		729.7 MHz	737.5 MHz	745.3 MHz
	RX (3M)	Channel 5025	Channel 5095	Channel 5165
		730.5 MHz	737.5 MHz	744.5 MHz
	RX(5M)	Channel 5035	Channel 5095	Channel 5155
		731.5 MHz	737.5 MHz	743.5 MHz
	RX (10M)	Channel 5060	Channel 5095	Channel 5130
		734 MHz	737.5 MHz	741 MHz
Test Mode	TX / RX	RF Channel		
		Low (B)	Middle (M)	High (T)
LTE Band 13	TX (5M)	Channel 23205	Channel 23230	Channel 23255
		779.5	782	784.5
	TX (10M)	Channel 23230	Channel 23230	Channel 23230
		782	782	782
	RX (5M)	Channel 5205	Channel 5230	Channel 5255
		748.5	751	753.5
	RX (10M)	Channel 5230	Channel 5230	Channel 5230
		751	751	751
Test Mode	TX / RX	RF Channel		
		Low (B)	Middle (M)	High (T)
		Channel 23755	Channel 23790	Channel 23825

Total Quality. Assured.

LTE Band 17	TX (5M)	706.5 MHz	710 MHz	713.5 MHz
	TX (10M)	Channel 23780	Channel 23790	Channel 23800
		709 MHz	710 MHz	711 MHz
	RX (5M)	Channel 5755	Channel 5790	Channel 5825
		736.5 MHz	740 MHz	743.5 MHz
	RX (10M)	Channel 5780	Channel 5790	Channel 5800
		739 MHz	740 MHz	741 MHz

4.0 DESCRIPTION OF TESTS

4.1. Radiated Power and Radiated Spurious Emissions

Radiated spurious emissions are investigated indoors in a semi-anechoic chamber to determine the frequencies producing the worst case emissions. Final measurements for radiated power and radiated spurious emissions are performed on the 3 meter OATS per the guidelines of ANSI/TIA-603-C-2004. The equipment under test was transmitting while connected to its integral antenna and is placed on a wooden turntable 80cm above the ground plane and 3 meters from the receive antenna. The spectrum is scanned from the lowest frequency generated in the equipment up to a frequency including its 10th harmonic. The receive antenna height is adjusted between 1 and 4 meter height, the turntable is rotated through 360 degrees, and the EUT is manipulated through all orthogonal planes representative of its typical use to achieve the highest reading on the receive spectrum analyzer. Emissions are also investigated with the receive antenna horizontally and vertically polarized.

A portable or small unlicensed wireless device shall be placed on a non-metallic test fixture or other non-metallic support during testing. The supporting fixture shall permit orientation of the EUT in each of three orthogonal (x, y, z) axis positions such that emissions from the EUT are maximized. Measure the EUT maximum RF power and record the result.

A half-wave dipole is then substituted in place of the EUT. For emissions above 3GHz, a horn antenna is substituted in place of the EUT. The substitute antenna is driven by a signal generator with the level of the signal generator being adjusted to obtain the same receive spectrum analyzer level previously recorded from the spurious emission from the EUT.

The power of the emission is calculated using the following formula:

$$P_d [\text{dBm}] = P_g [\text{dBm}] - \text{cable loss} [\text{dB}] + \text{antenna gain} [\text{dBd/dBi}]$$

Where, P_d is the dipole equivalent power, P_g is the generator output into the substitution antenna, and the antenna gain is the gain of the substitute antenna used relative to either a half-wave dipole (dBd) or an isotropic source (dBi). The substitute level is equal to $P_g [\text{dBm}] - \text{cable loss} [\text{dB}]$.

The calculated P_d levels are then compared to the absolute spurious emission limit of -13dBm which is equivalent to the required minimum attenuation of $43 + 10\log_{10}(\text{Power} [\text{Watts}])$.

Test Procedures Used

KDB 971168 v02r02-Section 5.2.1 / KDB 971168 v02R02-Section 5.8

ANSI/TIA-603-C-2004-Section 2.2.17 / ANSI/TIA-603-C-2004-Section 2.2.12

Note: Reference test setup 3

4.2 Peak-Average Ratio

A peak to average ratio measurement is performed at the conducted port of the EUT. For WCDMA signals, the spectrum analyzers Complementary Cumulative Distribution Function (CCDF) measurement profile is used to determine the largest deviation between the average and the peak power of the EUT in a given bandwidth. The CCDF curve shows how much time the peak waveform spends at or above a given average power level. The percent of time the signal spends at or above the level defines the probability for that particular power level. For GSM signals, an average and a peak trace are used on a spectrum analyzer to determine the largest deviation between the average and the peak power of the EUT in a bandwidth greater than the emission bandwidth. The traces are generated with the spectrum analyzer set to zero span mode.

Test Procedures Used

KDB 971168 v02r02-Section 5.7.1

Test Settings

- 1、 The signal analyzer's CCDF measurement profile enabled
- 2、 Frequency= carrier center frequency
- 3、 Measurement BW > EBW of signal
- 4、 for continuous transmissions, set to 1ms
- 5、 Record the maximum PAPR level associated with a probability of 0.1%.

Note: Reference test setup 1

4.3 Occupied Bandwidth

The occupied bandwidth, that is the frequency bandwidth such that, below its lower and above its upper frequency limits, the mean powers radiated are each equal to 0.5 percent of the total mean power radiated by a given emission shall be measured. The span of the analyzer shall be set to capture all products of the modulation process, including the emission skirts. The resolution bandwidth shall be set to as close to 1 percent of the selected span as is possible without being below 1 percent. The video bandwidth shall be set to 3 times the resolution bandwidth. Video averaging is not permitted. Where practical, a sampling detector shall be used since a peak or, peak hold, may produce a wider bandwidth than actual. The trace data points are recovered and are directly summed in linear terms. The recovered amplitude data points, beginning at the lowest frequency, are placed in a running sum until 0.5 percent of the total is reached and that frequency recorded. The process is repeated for the highest frequency data points. This frequency is recorded. The span between the two recorded frequencies is the occupied bandwidth.

Test Procedures Used

KDB 971168 v02r02-Section 4.2

Test Settings

- 1、 SET RBW=1-5% of OBW
- 2、 SET VBW ≥ 3 *RBW
- 3、 Detector: Peak
- 4、 Trace mode= max hold.
- 5、 Sweep= auto couple
- 6、 Steps 1-5 were repeated after it is stable

Note: Reference test setup 1.

4.4 Band Edge Compliance

the 1 MHz bands immediately outside and adjacent to the frequency block a resolution bandwidth of at least one percent of the emission bandwidth of the fundamental emission of the transmitter may be employed. The emission power must be attenuated below the transmitting power (P) by a factor of at least $43+10\log_{10}P$ dB.

Test Procedures Used

KDB 971168 v02r02-Section 6.0

Test Settings

- 1、 SET RBW \geq 1% of Emission BW.
- 2、 SET VBW about three times of RBW
- 3、 Detector: RMS
- 4、 Trace mode= max hold.
- 5、 Span= 2MHz

Note: Reference test setup 1.

4.5 Spurious and Harmonic Emissions at Antenna Terminal

The level of the carrier and the various conducted spurious and harmonic frequencies is measured by means of a calibrated spectrum analyzer. The spectrum is scanned from the lowest frequency generated in the equipment up to a frequency including its 10th harmonic. On any frequency outside a licensee's frequency block, the power of any emission shall be attenuated below the transmitter power (P) by at least $43 + 10 \log(P)$ dB. Compliance with these provisions is based on the use of measurement instrumentation employing a resolution bandwidth of 1 MHz or greater. However, in the 1 MHz bands immediately outside and adjacent to the frequency block a resolution bandwidth of at least one percent of the emission bandwidth of the fundamental emission of the transmitter may be employed. The emission bandwidth is defined as the width of the signal between two points, one below the carrier center frequency and one above the carrier center frequency, outside of which all emission are attenuated at least 26 dB below the transmitter power.

Test Procedures Used

KDB 971168 v02r02-Section 6.0

Test Settings

- 1、 9kHz~150kHz, RBW = 1KHz, VBW $\geq 3 \times$ RBW,
150kHz~30MHz, RBW = 10KHz, VBW $\geq 3 \times$ RBW,
30MHz~1GHz, RBW = 100 kHz, VBW = 300 kHz.
Above 1GHz, RBW = 1 MHz, VBW = 3 MHz.

2、 Detector: Peak

3、 Trace mode= max hold.

Note: Reference test setup 1.

4.6 Frequency Stability / Temperature Variation

Frequency stability testing is performed in accordance with the guidelines of ANSI/TIA-603-C-2004. The frequency stability of the transmitter is measured by:

- a.) **Temperature:** The temperature is varied from -20°C to +60°C in 20°C increments using an environmental chamber.
- b.) **Primary Supply Voltage:** The primary supply voltage is varied from 85% to 115% of the nominal value for non hand-carried battery and AC powered equipment. For hand-carried, battery-powered equipment, primary supply voltage is reduced to the battery operating end point which shall be specified by the manufacturer.

Specification – The frequency stability shall be sufficient to ensure that the fundamental emission stays within the authorized frequency block. The frequency stability of the transmitter shall be maintained within $\pm 0.00025\%$ (± 2.5 ppm) of the center frequency.

Time Period and Procedure:

1. The carrier frequency of the transmitter is measured at room temperature (20°C to provide a reference).
2. The equipment is turned on in a “standby” condition for fifteen minutes before applying power to the transmitter. Measurement of the carrier frequency of the transmitter is made within one minute after applying power to the transmitter.
3. Frequency measurements are made at 20°C intervals ranging from -20°C to +60°C. A period of at least one half-hour is provided to allow stabilization of the equipment at each temperature level.

Test Procedures Used

ANSI/TIA-603-C-2004

Note: Reference test setup 2.

5.0 Test Setups

5.1 Test Setup 1

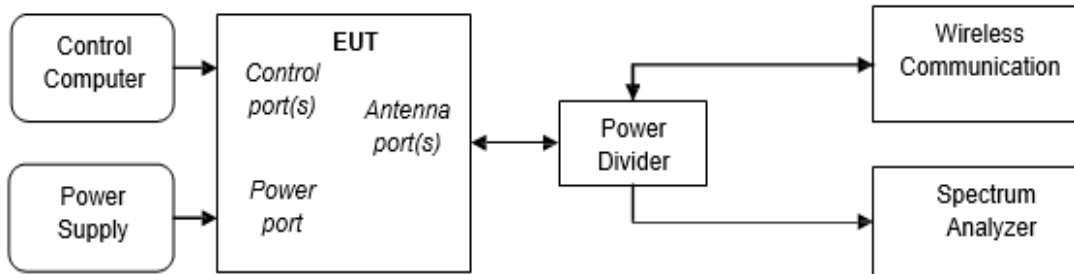

5.2 Test Setup 2

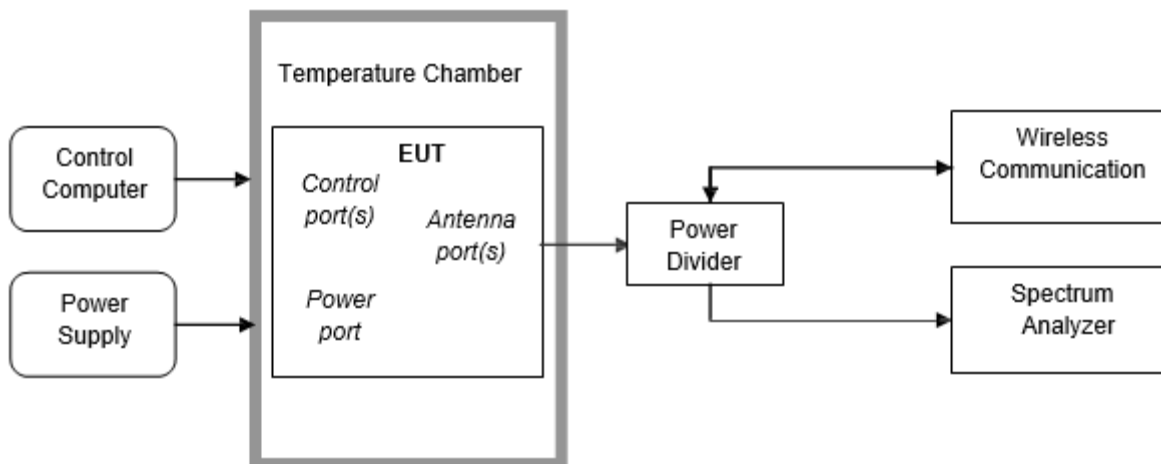

5.3 Test Setup 3

NOTE: Effective radiated power (ERP) and Equivalent Isotropic Radiated Power (EIRP) refers to the radiation power output of the EUT, assuming all emissions are radiated from half-wave dipole antennas.

5.3.1 Step 1: Pre-test

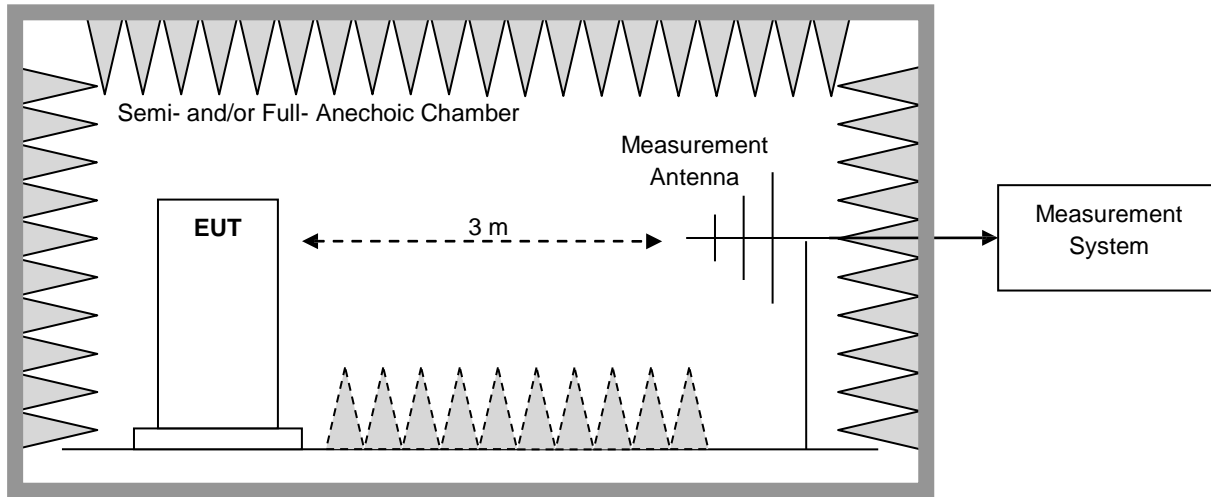

5.3.2 Step 2: Substitution method to verify the maximum ERP/EIRP

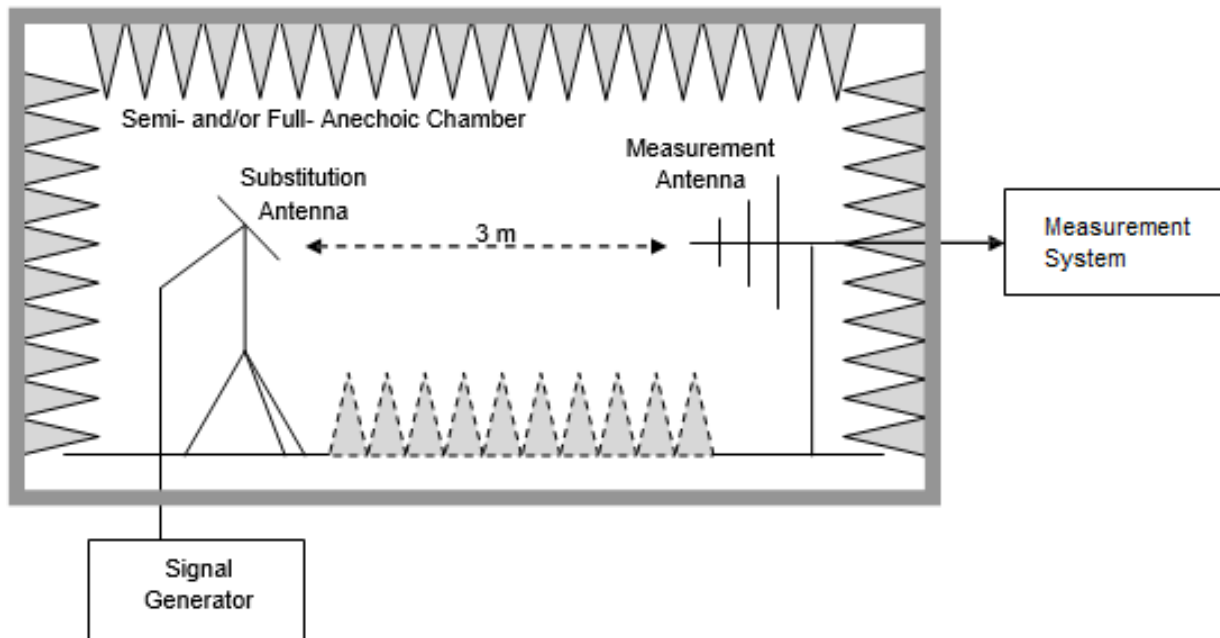

5.4 Test Conditions

Test Case		Test Conditions	
Transmit Output Power Data	Average Power, Total	Test Env.	Ambient Climate & Rated Voltage
		Test Setup	Test Setup 1
		RF Channels (TX)	L, M, H (L= low channel, M= middle channel, H= high channel)
		Test Mode	GSM/TM1,GSM/TM2,UMTS/TM1,LTE/TM1,LTE/TM2
	Average Power, Spectral Density (if required)	Test Env.	Ambient Climate & Rated Voltage
		Test Setup	Test Setup 1
		RF Channels (TX)	L, M, H (L= low channel, M= middle channel, H= high channel)
		Test Mode	GSM/TM1,GSM/TM2,UMTS/TM1,LTE/TM1,LTE/TM2
Peak-to-Average Ratio (if required)		Test Env.	Ambient Climate & Rated Voltage
		Test Setup	Test Setup 1
		RF Channels (TX)	L, M, H (L= low channel, M= middle channel, H= high channel)
		Test Mode	GSM/TM1,GSM/TM2,UMTS/TM1,LTE/TM1,LTE/TM2
Modulation Characteristics		Test Env.	Ambient Climate & Rated Voltage
		Test Setup	Test Setup 1
		RF Channels (TX)	M (L= low channel, M= middle channel, H= high channel)
		Test Mode	GSM/TM1,GSM/TM2,UMTS/TM1,LTE/TM1,LTE/TM2
Bandwidth	Occupied Bandwidth	Test Env.	Ambient Climate & Rated Voltage
		Test Setup	Test Setup 1
		RF Channels (TX)	L, M, H (L= low channel, M= middle channel, H= high channel)
		Test Mode	GSM/TM1,GSM/TM2,UMTS/TM1,LTE/TM1,LTE/TM2
	Emission Bandwidth (if required)	Test Env.	Ambient Climate & Rated Voltage
		Test Setup	Test Setup 1
		RF Channels (TX)	L, M, H (L= low channel, M= middle channel, H= high channel)
		Test Mode	GSM/TM1,GSM/TM2,UMTS/TM1,LTE/TM1,LTE/TM2
Band Edges Compliance		Test Env.	Ambient Climate & Rated Voltage
		Test Setup	Test Setup 1
		RF Channels (TX)	L, H (L= low channel, M= middle channel, H= high channel)
		Test Mode	GSM/TM1,GSM/TM2,UMTS/TM1,LTE/TM1,LTE/TM2
Spurious Emission at Antenna Terminals		Test Env.	Ambient Climate & Rated Voltage
		Test Setup	Test Setup 1
		RF Channels (TX)	L, M, H (L= low channel, M= middle channel, H= high channel)

Test Case	Test Conditions	
	Test Mode	GSM/TM1,GSM/TM2,UMTS/TM1,LTE/TM1,LTE/TM2
Field Strength of Spurious Radiation	Test Env.	Ambient Climate & Rated Voltage
	Test Setup	Test Setup 3
	Test Mode	GSM/TM1,GSM/TM2,UMTS/TM1/TM2/TM3,LTE/TM1,LTE/TM2 NOTE: If applicable, the EUT conf. that has maximum power density (based on the equivalent power level) is selected.
	RF Channels (TX)	L, M, H (L= low channel, M= middle channel, H= high channel)
Frequency Stability	Test Env.	(1) -30 °C to +50 °C with step 10 °C at Rated Voltage; (2) VL, VN and VH of Rated Voltage at Ambient Climate.
	Test Setup	Test Setup 2
	RF Channels (TX)	L, M, H (L= low channel, M= middle channel, H= high channel)
	Test Mode	GSM/TM1,GSM/TM2,UMTS/TM1,LTE/TM1,LTE/TM2

6.0 Main Test Instruments

Main Test Equipment					
Equip No.	Equipment Name	Manufacturer	Model	Cal Date	Cal- Due
SZ006-27	DC Power Supply	Keysight	E3648A	2020-06-18	2020-12-18
SZ065-08	Wideband Radio Communication Tester	R & S	CMW 500	2020-05-27	2021-05-27
SZ065-07	Wideband Radio Communication Tester	R & S	CMW 500	2020-05-27	2021-05-27
SZ056-07	Signal Analyzer	R&S	FSV40	2019-10-29	2020-10-29
SZ016-12	Programmable Temperature & Humidity Chamber	TaiLi	MHK-120NK	2020-01-14	2021-01-14
SZ047-35	Digital Temperature-Humidity Recorder	YiJie	RS210	2020-07-23	2021-07-23
SZ061-12	Biconilog Antenna	ETS	3142E	2018-09-14	2020-09-14
SZ061-06	Active Loop Antenna	Electro-Metrics	EM-6876	2019-05-24	2021-05-24
SZ061-08	Horn Antenna	ETS	3115	2019-09-07	2021-09-07
SZ061-07	Pyramidal Horn Antenna	ETS	3160-09	2019-08-13	2021-08-13
SZ056-03	Spectrum Analyzer	R&S	FSP30	2020-05-27	2021-05-27
SZ185-01	EMI Receiver	R & S	ESCI	2019-12-24	2020-12-24
SZ181-04	Preamplifier	Agilent	8449B	2020-05-27	2021-05-27
SZ188-01	Anechoic Chamber	ETS	RFD-F/A-100	2018-12-15	2021-12-15
SZ062-02	RF Cable	RADIALL	RG 213U	2020-06-12	2020-12-12
SZ062-05	RF Cable	RADIALL	0.04-26.5GHz	2020-08-10	2021-02-10
SZ062-12	RF Cable	RADIALL	0.04-26.5GHz	2020-08-10	2021-02-10
SZ067-04	Notch Filter	Micro-Tronics	BRM50702-02	2020-05-27	2021-05-27
Software Information					
Test Item	Software Name	Manufacturer	Version		
RSE	EMC32	R&S	V8.40.0		
Conducted RF	JS1120 RF Test System	Shenzhen JS tonscond co., Ltd	2.6.9.0518		

7.0 Measurement Uncertainty

For a 95% confidence level ($k = 2$), the measurement expanded uncertainties for defined systems, in accordance with the recommendations of ISO 17025 as following:

Test Item		Extended Uncertainty
Transmit Output Power Data	Power [dBm]	U = 0.42 dB
Bandwidth	Magnitude [%]	U = 0.2%
Band Edge Compliance	Disturbance Power [dBm]	U = 1.24 dB
Spurious Emissions, Conducted	Disturbance Power [dBm]	U = 1.62 dB
Field Strength of Spurious Radiation	ERP [dBm]	For 3 m Chamber: U = 4.9 dB (30 MHz to 26.5GHz)
Frequency Stability	Frequency Accuracy [ppm]	U = 0.017 ppm

8.0 Appendixes

Appendix No.	Description
200810035SZN-001-Appendix A	Appendix for GSM
200810035SZN-001-Appendix B	Appendix for WCDMA
200810035SZN-001-Appendix C	Appendix for LTE B2
200810035SZN-001-Appendix D	Appendix for LTE B4
200810035SZN-001-Appendix E	Appendix for LTE B5
200810035SZN-001-Appendix F	Appendix for LTE B7
200810035SZN-001-Appendix G	Appendix for LTE B12
200810035SZN-001-Appendix H	Appendix for LTE B13
200810035SZN-001-Appendix I	Appendix for LTE B17

END