



TESTREPORT

No.I19N02638-EMC

for

Yulong Computer Telecommunication Scientific (Shenzhen) Co., Ltd

Mobile Hotspot

Model Name:cp332A

With

FCC ID: R38YLCP332A

Hardware Version: P1

Software Version: 2.0.255.P0.190919.cp332A

Issued Date: 2019-11-26

Designation Number: CN1210

Note:

The test results in this test report relate only to the devices specified in this report. This report shall not be reproduced except in full without the written approval of SAICT.

Test Laboratory:

Shenzhen Academy of Information and Communications Technology
Building G, Shenzhen International Innovation Center, No.1006 Shennan Road, Futian District, Shenzhen,
Guangdong, P. R. China 518026.

Tel:+86(0)755-33322000, Fax:+86(0)755-33322001Email:yewu@caict.ac.cn.www.cszit.com

REPORT HISTORY

Report Number	Revision	Description	Issue Date
I19N02638-EMC	Rev.0	1st edition	2019-11-26

CONTENTS

1. SUMMARY OF TEST REPORT.....	5
1.1. TEST ITEMS.....	5
1.2. TEST STANDARDS.....	5
1.3. TEST RESULT.....	5
1.4. TESTING LOCATION.....	5
1.5. PROJECT DATA.....	5
1.6. SIGNATURE.....	5
2. CLIENT INFORMATION.....	6
2.1. APPLICANT INFORMATION.....	6
2.2. MANUFACTURER INFORMATION.....	6
3. EQUIPMENT UNDERTEST (EUT) AND ANCILLARY EQUIPMENT (AE).....	7
3.1. ABOUT EUT.....	7
3.2. INTERNAL IDENTIFICATION OF EUT.....	7
3.3. INTERNAL IDENTIFICATION OF AE.....	7
3.4. EUT SET-UPS.....	8
4. REFERENCE DOCUMENTS.....	9
4.1. REFERENCE DOCUMENTS FOR TESTING.....	9
5. LABORATORY ENVIRONMENT.....	10
6. SUMMARY OF TEST RESULTS.....	11
6.1. TESTING ENVIRONMENT.....	11
6.2. SUMMARY OF MEASUREMENT RESULTS.....	11
6.3. STATEMENT.....	11
7. MEASUREMENT UNCERTAINTY.....	12
8. TEST FACILITIES UTILIZED.....	12
ANNEX A: MEASUREMENT RESULTS.....	13
A.1 RADIATED EMISSION (§ 15.109(A)).....	13
A.2 CONDUCTED EMISSION (§ 15.107(A)).....	18
ANNEX B: THE REPORT OF THE INITIAL MODEL.....	22
B.1 TEST LABORATORY.....	22
B.2 EQUIPMENT UNDER TEST (EUT) AND ANCILLARY EQUIPMENT (AE).....	22

B.3 REFERENCE DOCUMENTS.....	24
B.4 LABORATORY ENVIRONMENT.....	25
B.5 SUMMARY OF TEST RESULTS.....	26
B.6 TEST FACILITIES UTILIZED.....	27
B.7 MEASUREMENT RESULTS.....	28

1. Summary of Test Report

1.1. Test Items

Description	Mobile Hotspot
Model Name	cp332A
Applicant's name	Yulong Computer Telecommunication Scientific (Shenzhen) Co., Ltd
Manufacturer's Name	Yulong Computer Telecommunication Scientific (Shenzhen) Co., Ltd

1.2. Test Standards

Please refer to "4. Reference Documents"

1.3. Test Result

Please refer to "6.2 Test Results"

1.4. Testing Location

Address: Building G, Shenzhen International Innovation Center, No.1006
Shennan Road, Futian District, Shenzhen, Guangdong, China

1.5. Project data

Testing Start Date: 2019-11-19
Testing End Date: 2019-11-25

1.6. Signature

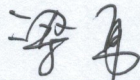

Liang Yong

(Prepared this test report)

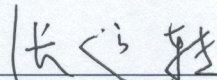

Zhang Yunzhan

(Reviewed this test report)

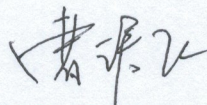

Cao Junfei

Director of the laboratory

(Approved this test report)

2. ClientInformation

2.1. Applicant Information

Company Name: Yulong Computer Telecommunication Scientific (Shenzhen) Co., Ltd
Address: Building B, Boton Science Park, Chaguang Road, Xili Town, Nanshan
District, Shenzhen
Contact: Yentl Chen
E-mail: chenyanting@yulong.com
Tel: +86 15927320221

2.2. Manufacturer Information

Company Name: Yulong Computer Telecommunication Scientific (Shenzhen) Co., Ltd
Address: Building B, Boton Science Park, Chaguang Road, Xili Town, Nanshan
District, Shenzhen
Contact: Yentl Chen
E-mail: chenyanting@yulong.com
Tel: +86 15927320221

3. Equipment Under Test (EUT) and Ancillary Equipment (AE)

3.1. About EUT

Description	Mobile Hotspot
Model Name	cp332A
FCC ID	R38YLCP332A
Condition of EUT as received	No obvious damage in appearance

The Equipment Under Test (EUT) is a model of mobile hotspot with integrated antenna.

Note 1: The above EUT's information is declared by manufacturer. Please refer to the specifications or user's manual for more detailed information.

Note 2: Mobile Hotspot cp332A manufactured by Yulong Computer Telecommunication Scientific (Shenzhen) Co., Ltd . have some changes:

- (1) New software supports both JSC and EMST memory.
- (2) The difference between JSC and EMST memory is vendor.

Note 3: According to the declaration of differences by manufacturer, the following tests need to be performed at the USB mode from the report of the initial model:

No.	Test item
1	Radiated Emission
2	Conducted Emission

Other results are cited from the initial report, see ANNEX B.

The report number for initial model is I18N01882-EMC.

3.2. Internal Identification of EUT

EUT ID*	SN or IMEI	HW Version	SW Version	Receive Date
UT01aa	867695041078063	P1	2.0.255.P0.190919.cp332A	2019-11-19

*EUT ID: is used to identify the test sample in the lab internally.

3.3. Internal Identification of AE

AE ID*	Description	SN
AE1	Battery	/
AE2	Charger	/
AE3	Data Cable	

AE1

Model	Rechargeable Li-ion Battery
Manufacturer	LISHEN
Capacitance	2600 mAh
Nominal Voltage	3.8V

AE2-1

Model	RD0501000-USBA-18MG
Manufacturer	Shenzhen Ruide
AE2-2	
Model	618045
Manufacturer	Shenzhen Kosun
AE3	
Model	Micro Cable
Manufacturer	Shenzhen Saibao.

*AE ID: is used to identify the test sample in the lab internally.

3.4. EUT set-ups

EUT set-up No.	Combination of EUT and AE	Remarks
Set.1	UT01aa+AE1+AE3	USB mode

4. Reference Documents

4.1. Reference Documents for testing

The following documents listed in this section are referred for testing.

Reference	Title	Version
FCC Part 15, Subpart B	Radio frequency devices	10-1-2018 Edition
ANSI C63.4	Methods of Measurement of Radio-Noise Emissions from Low-Voltage Electrical and Electronic Equipment in the Range of 9 kHz to 40 GHz	2014

5. LABORATORY ENVIRONMENT

Semi-anechoic chamber did not exceed following limits along the EMC testing:

9.10m×6.10m×5.60m(L×W×H)

Temperature	Min. = 15 °C, Max. = 35 °C
Relative humidity	Min. = 15 %, Max. = 75 %
Shielding effectiveness	0.014MHz-1MHz,>60dB; 1MHz-18000MHz,>90dB
Electrical insulation	>2MΩ
Ground system resistance	<4Ω
Normalised site attenuation (NSA)	<±4 dB, 3 m distance, from 30 to 1000 MHz

Shield room did not exceed following limits along the EMC testing:

Temperature	Min. = 15 °C, Max. = 30 °C
Relative humidity	Min. =20 %, Max. = 75 %
Shielding effectiveness	0.014MHz-1MHz,>60dB; 1MHz-10000MHz,>90dB
Electrical insulation	>2MΩ
Ground system resistance	<4Ω

Fully-anechoic chamber did not exceed following limits along the EMC testing:

9.10m×6.10m×5.60m(L×W×H)

Temperature	Min. = 15 °C, Max. = 35 °C
Relative humidity	Min. = 15 %, Max. = 75 %
Shielding effectiveness	0.014MHz-1MHz,>60dB; 1MHz-18000MHz,>90dB
Electrical insulation	>2MΩ
Ground system resistance	<4Ω
VoltageStandingWaveRatio (VSWR)	≤ 6 dB, from 1 to 18GHz, 3 m distance
Uniformity of field strength	Between 0 and 6 dB, from 80 to 6000 MHz

6. SUMMARY OF TEST RESULTS

6.1. Testing Environment

Normal Temperature: 15~35℃
Relative Humidity: 20~75%
Atmospheric pressure 86~106kPa

6.2. Summary of Measurement Results

Abbreviations used in this clause:	
P	Pass
NA	Not applicable
F	Fail

Items	Test Name	Clause in FCC rules	Section in this report	Verdict
1	Radiated Emission	15.109(a)	A.1	P
2	Conducted Emission	15.107(a)	A.2	P

6.3. Statement

6.3.1 Statements of conformity

This report takes measured values as criterion of test conclusion. The test conclusion meets the limit requirements.

7. Measurement uncertainty

Test item	Frequency ranges	Measurement uncertainty
RE	30MHz-1GHz	4.9dB(k=2)
	1GHz-18GHz	4.6dB(k=2)
CE	150kHz-30MHz	3.0dB(k=2)

8. Test Facilities Utilized

NO.	NAME	TYPE	SERIES NUMBER	PRODUCER	CALDUE DATE	CAL PERIOD
1.	Test Receiver	ESR7	101676	R&S	2019.11.28	1 year
2.	Spectrum Analyzer	FSV40	101192	R&S	2020.05.19	1 year
3.	BiLog Antenna	3142E	00224831	ETS-lindgren	2021.05.17	3 years
4.	Horn Antenna	3117	00066577	ETS-lindgren	2022.04.02	3 years
5.	Chamber	FACT3-2.0	1285	ETS-Lindgren	2021.07.19	2 years
6.	Software	EMC32	V10.01.00	R&S	/	/
7.	PC	ThinkPad E480	PF-0Z56NV	Lenovo	/	/
8.	Printer	P1008	VNF6C12491	HP	/	/
9.	Mouse	MOEUUOA	44NY517	Lenovo	/	/
10.	Test Receiver	ESCI	100702	R&S	2020.06.19	1 year
11.	LISN	ENV216	102067	R&S	2020.07.17	1 year

ANNEX A: MEASUREMENT RESULTS

A.1 Radiated Emission (§15.109(a))

Reference

FCC: CFR Part 15.109(a)

A.1.1 Method of measurement

The field strength of radiated emissions from the unintentional radiator at a distance of 3 meters is tested. Tested in accordance with the procedures of ANSI C63.4 -2014, section 8.3.

The EUT was placed on a non-conductive table. The measurement antenna was placed at a distance of 3 meters from the EUT. During the tests, the antenna height and the EUT azimuth were varied in order to identify the maximum level of emissions from the EUT. This maximization process was repeated with the EUT positioned in each of its three orthogonal orientations.

A.1.2 EUT Operating Mode:

USB mode: The model of the PC is Lenovo ThinkPadE480, and the serial number of the PC is PF-0Z56NV. The CMD.exe is used to let the PC keep on ping EUT's IP address, pinging EUT's IP address was until test finished.

A.1.3 Measurement Limit

Limit from CFR Part 15.109(a)

Frequency range (MHz)	Field strength limit ($\mu\text{V}/\text{m}$)		
	Quasi-peak	Average	Peak
30-88	100		
88-216	150		
216-960	200		
960-1000	500		
>1000		500	5000

*Note: The original limit is defined at 10m test distance. This limit is calculated according to CISPR requirements.

A.1.4 Test Condition

Frequency of emission (MHz)	RBW/VBW	Sweep Time(s)
30-1000	120kHz (IF bandwidth)	5
Above 1000	1MHz/3MHz	15

**A.1.5 Test set-up:
30MHz-1GHz**

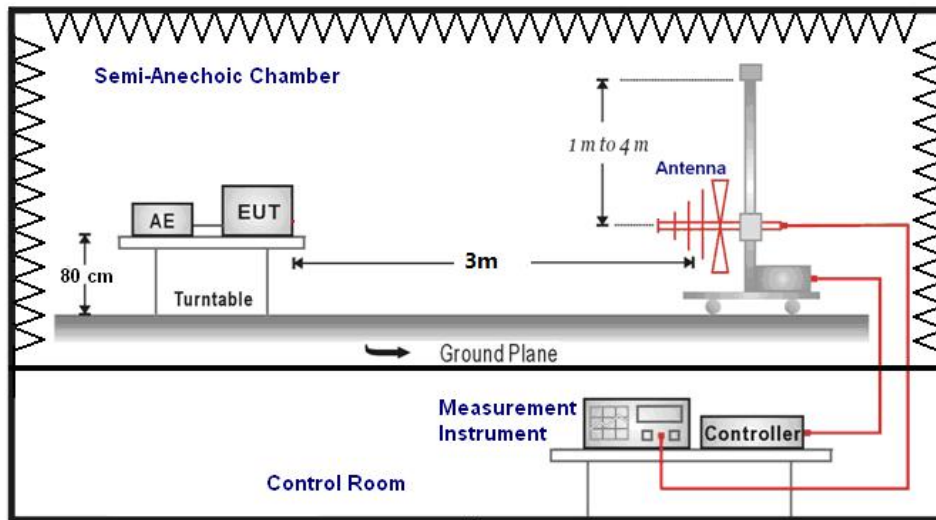

1GHz-18GHz

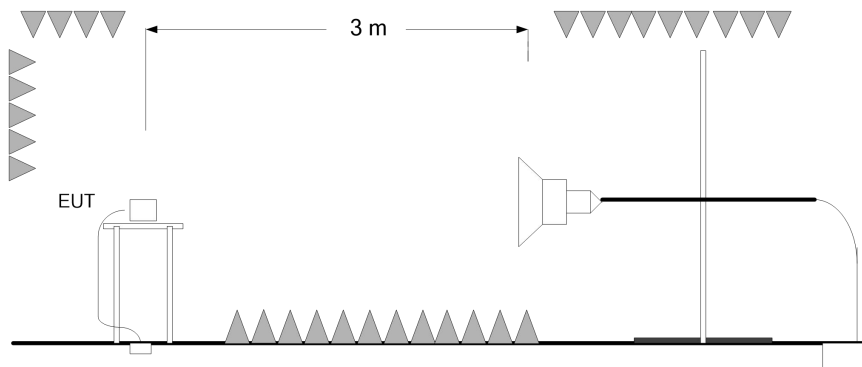

A.1.6 Measurement Results

A "reference path loss" is established and the A_{Rpl} is the attenuation of "reference path loss". It includes the antenna factor of receive antenna and the path loss.

The measurement results are obtained as described below:

$$\text{Result} = P_{\text{Mea}} + A_{Rpl} = P_{\text{Mea}} + G_A + G_{PL}$$

Where

G_A : Antenna factor of receive antenna

G_{PL} : Path Loss

P_{Mea} : Measurement result on receiver.

Note: the result contains vertical part and Horizontal part

Set.1 USB mode / Peak detector

Frequency(MHz)	Result(dBuV/m)	Limit (dB μ V/m)	Margin(dB)	Polarity	ARpl (dB/m)	P _{Mea} (dB μ V)
12098.5	52.06	74	21.94	V	16.1	35.96
12769.5	53.31	74	20.69	V	16.9	36.41
12919	53.52	74	20.48	V	17.1	36.42
14689.5	54.27	74	19.73	H	17.8	36.47
16560.5	57.02	74	16.98	V	21.9	35.12
17672.5	56.91	74	17.09	H	22.8	34.11

Set.1 USB mode / Average detector

Frequency(MHz)	Result(dBuV/m)	Limit (dB μ V/m)	Margin(dB)	Polarity	ARpl (dB/m)	P _{Mea} (dB μ V)
12657.5	41.32	54	12.68	V	17.3	24.02
13937.5	41.51	54	12.49	V	17.2	24.31
14682.5	42.33	54	11.67	H	17.8	24.53
15575	43.42	54	10.58	V	19.6	23.82
15657.5	45.17	54	8.83	H	20.1	25.07
17696	44.64	54	9.36	H	23.1	21.54

USB mode: Set 1

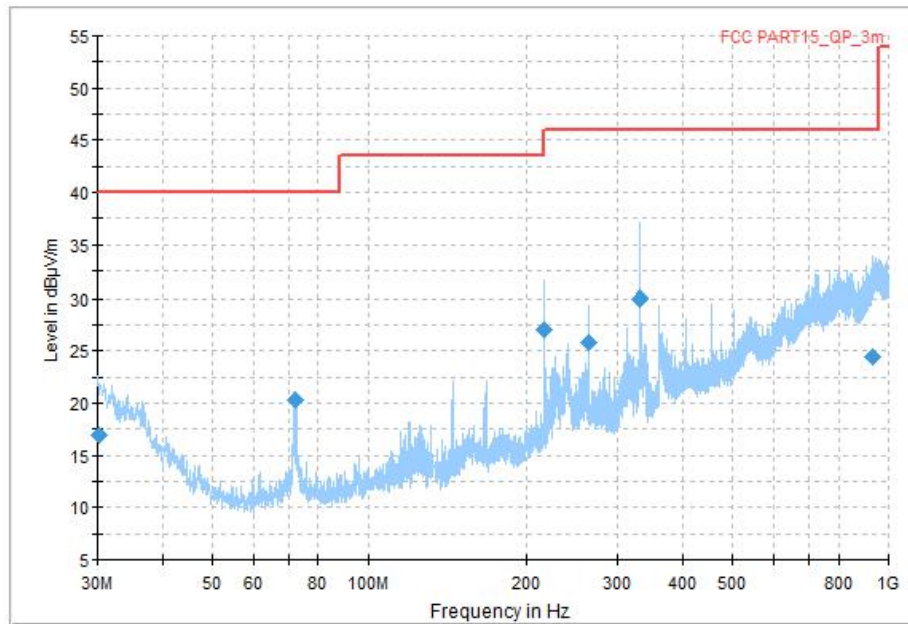

Figure A.1 Radiated Emission from 30MHz to 1GHz

Final_Result

Frequency(MHz)	Quasi-peak (dBµV/m)	Limit (dBµV/m)	Margin(dB)	Polarity	ARpl (dB/m)	P _{Mea} (dBµV)
30.12	16.99	40	23.01	V	-4.6	21.59
72.013125	20.36	40	19.64	V	-10.4	30.76
215.9575	26.98	43.52	16.54	H	-3.8	30.78
264.031875	25.83	46.02	20.19	H	-1.3	27.13
331.931875	29.99	46.02	16.03	H	-1.9	31.89
933.655625	24.45	46.02	21.57	H	11.1	13.35

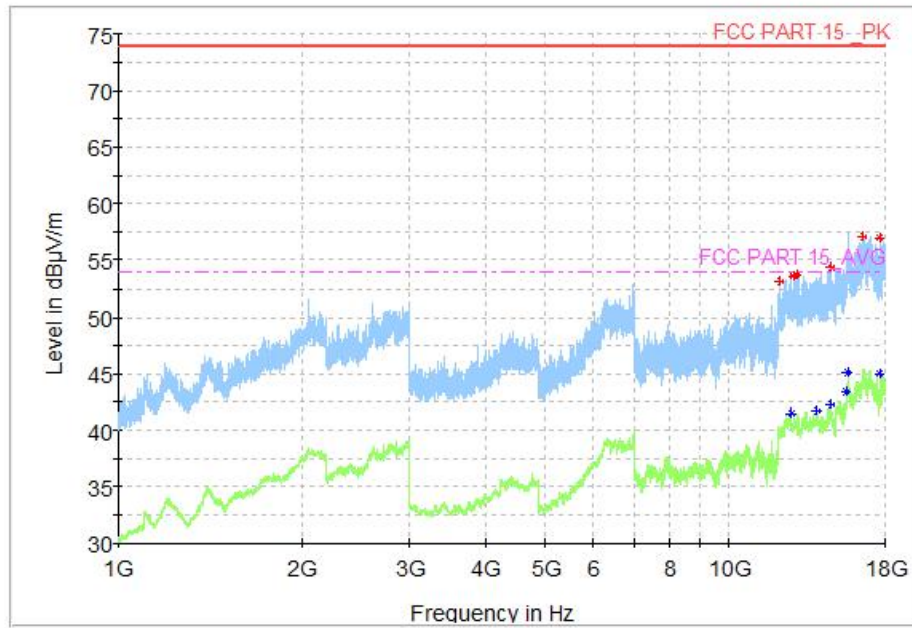

Figure A.2 Radiated Emission from 1GHz to 18GHz

A.2 Conducted Emission (§15.107(a))

Reference

FCC: CFR Part 15.107(a)

A.2.1 Method of measurement

For equipment that is designed to be connected to the public utility (AC) power line, the radio frequency voltage that is conducted back onto the AC power line on any frequency or frequencies within the band 150kHz to 30MHz shall not exceed the limits. Tested in accordance with the procedures of ANSI C63.4 -2014, section 7.3.

A.2.2 EUT Operating Mode:

USB mode: The model of the PC is Lenovo ThinkPadE480, and the serial number of the PC is PF-0Z56NV. The CMD.exe is used to let the PC keep on ping EUT's IP address, pinging EUT's IP address was until test finished.

A.2.3 Measurement Limit

Frequency of emission (MHz)	Conducted limit (dBµV)	
	Quasi-peak	Average
0.15-0.5	66 to 56*	56 to 46*
0.5-5	56	46
5-30	60	50

*Decreases with the logarithm of the frequency

A.2.4 Test set-up:

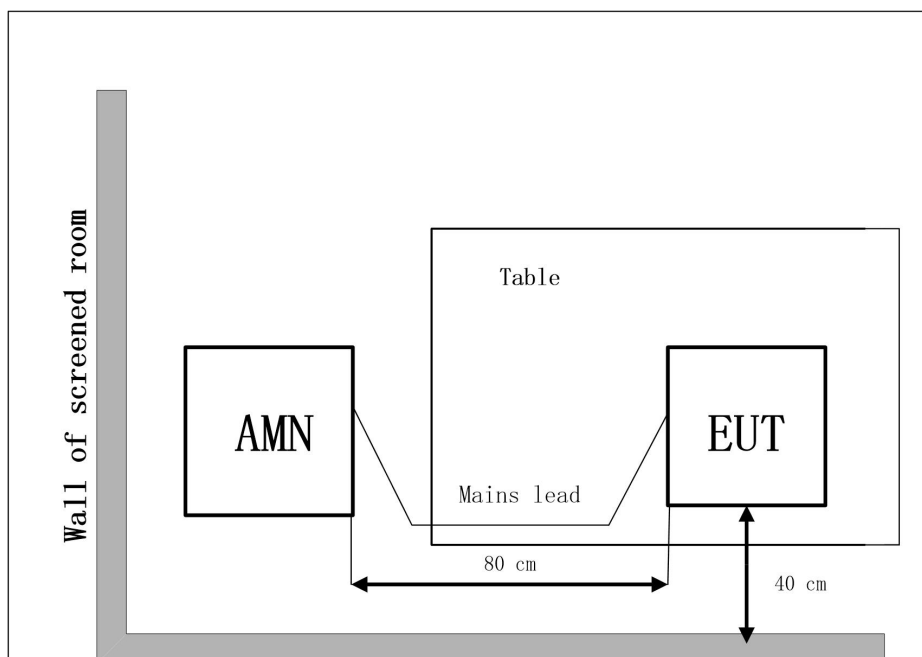

A.2.5 Test Condition in charging mode

Voltage (V)	Frequency (Hz)
120	50
240	50

RBW	Sweep Time(s)
9kHz	1

CE Measurement uncertainty: 3.10 dB (k=2)

A.2.6 Measurement Results

$$\text{QuasiPeak(dB}\mu\text{V)} / \text{Average(dB}\mu\text{V)} = P_{\text{Mea}} + \text{Corr}$$

Where

Corr: PathLoss + Voltage Division Factor

P_{Mea} : Measurement result on receiver.

USB mode: Set 1
Voltage: 120V

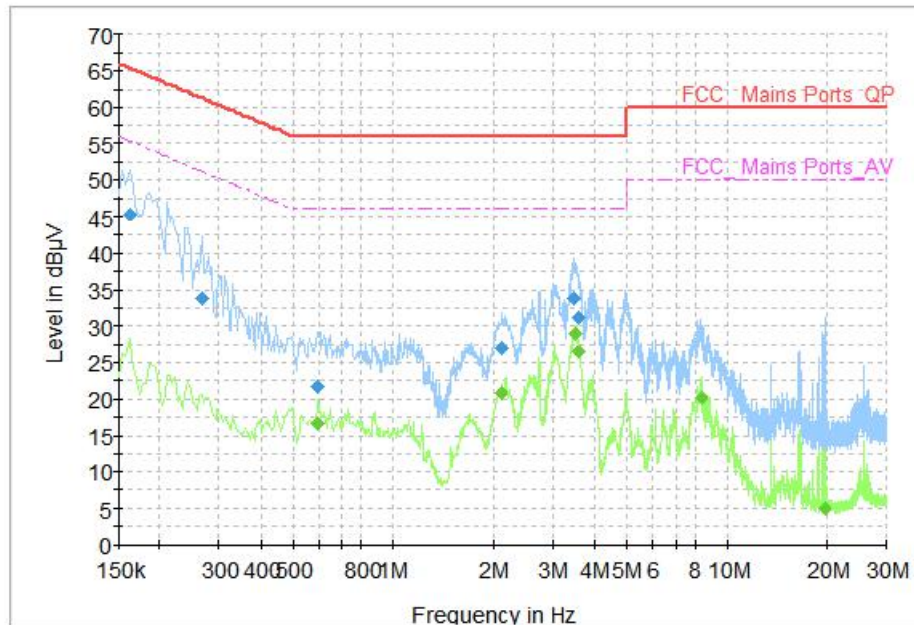

Figure A.3 Conducted Emission

Final Measurement Detector 1

Frequency (MHz)	QuasiPeak (dBµV)	Limit (dBµV)	Margin (dB)	Line	Corr. (dB)	PMea (dBµV)
0.162	45.28	65.36	20.08	N	9.6	35.68
0.266	33.9	61.24	27.35	L1	9.7	24.2
0.59	21.61	56	34.39	N	9.7	11.91
2.118	27.02	56	28.98	N	9.7	17.32
3.478	33.87	56	22.13	L1	9.7	24.17
3.622	31.23	56	24.77	N	9.7	21.53

Final Measurement Detector 2

Frequency (MHz)	Average (dBµV)	Limit (dBµV)	Margin (dB)	Line	Corr. (dB)	PMea (dBµV)
0.594	16.51	46	29.49	N	9.7	6.81
2.11	20.85	46	25.15	L1	9.7	11.15
3.506	28.98	46	17.02	L1	9.7	19.28
3.614	26.45	46	19.55	L1	9.7	16.75
8.342	20.12	50	29.88	N	9.8	10.32
19.522	4.85	50	45.15	L1	10.2	-5.35

USB mode: Set 1
Voltage: 240V

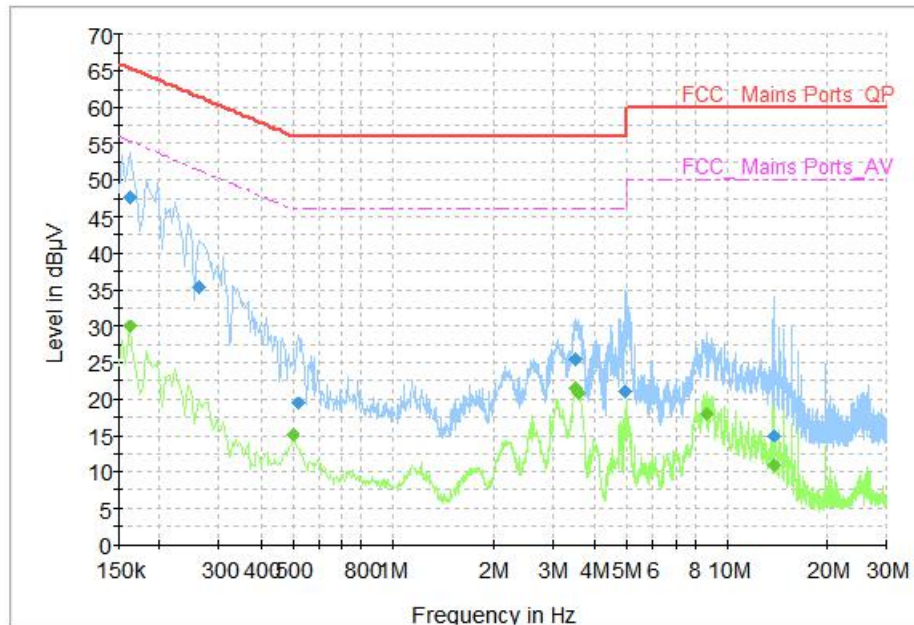

Figure A.4 Conducted Emission

Final Measurement Detector 1

Frequency (MHz)	QuasiPeak (dBµV)	Limit (dBµV)	Margin (dB)	Line	Corr. (dB)	PMea (dBµV)
0.162	47.67	65.36	17.69	N	9.6	38.07
0.262	35.27	61.37	26.1	N	9.6	25.67
0.518	19.46	56	36.54	L1	9.7	9.76
3.506	25.42	56	30.58	N	9.7	15.72
4.954	20.91	56	35.09	N	9.7	11.21
13.85	14.98	60	45.02	L1	10.1	4.88

Final Measurement Detector 2

Frequency (MHz)	Average (dBµV)	Limit (dBµV)	Margin (dB)	Line	Corr. (dB)	PMea (dBµV)
0.162	29.99	55.36	25.37	N	9.6	20.39
0.502	15.23	46	30.77	L1	9.7	5.53
3.53	21.59	46	24.41	L1	9.7	11.89
3.606	20.88	46	25.12	L1	9.7	11.18
8.642	17.91	50	32.09	N	9.8	8.11
13.85	10.98	50	39.02	L1	10.1	0.88

END OF REPORT

ANNEX B: The report of the initial model

B.1 Test Laboratory

B.1.1 Testing Location

Company Name: CTTL Shenzhen
Address: Building G, Shenzhen International Innovation Center, No.1006
Shennan Road, Futian District, Shenzhen, Guangdong, China
Postal Code: 518000
Telephone: +86-755-33322000
Fax: +86-755-33322001

B.1.2 Testing Environment

Normal Temperature: 15-35°C
Relative Humidity: 20-75%
Atmospheric pressure 86kPa-106kPa

F.1.3 Project data

Testing Start Date: 2019-10-21
Testing End Date: 2019-10-31

B.2 Equipment Under Test (EUT) and Ancillary Equipment (AE)

About EUT

Description	Mobile Hotspot
Model Name	cp332A
FCC ID	R38YLCP332A
Condition of EUT as received	No obvious damage in appearance

The Equipment Under Test (EUT) is a model of Mobile Hotspot with integrated antenna.

Remark: The above EUT's information is declared by manufacturer. Please refer to the specifications or user's manual for more detailed information.

Internal Identification of EUT

EUT ID*	SN or IMEI	HW Version	SW Version
UT01aa	867695040000746	P1	2.0.057.P0.181214.cp332A

*EUT ID: is used to identify the test sample in the lab internally.

Internal Identification of AE

AE ID*	SN	Description
AE1	/	Battery
AE2	/	Charger
AE3	/	Data Cable

AE1

Model	Rechargeable Li-ion Battery
Manufacturer	LISHEN
Capacitance	2600 mAh
Nominal Voltage	3.8V

AE2-1

Model	RD0501000-USBA-18MG
Manufacturer	Shenzhen Ruide

AE2-2

Model	618045
Manufacturer	Shenzhen Kosun

AE3

Model	Micro Cable
Manufacturer	Shenzhen Saibao.

*AE ID: is used to identify the test sample in the lab internally.

EUT set-ups

EUT set-up No.	Combination of EUT and AE	Remarks
Set.1	EUT1+ AE1+AE2-1+AE3	Charging mode
Set.2	EUT2+ AE1+AE2-2+AE3	Charging mode
Set.3	EUT1+AE3	USB mode

B.3 Reference Documents

Reference Documents for testing

The following documents listed in this section are referred for testing.

Reference	Title	Version
FCC Part 15, Subpart B	Radio frequency devices	10-1-2017 Edition
ANSI C63.4	Methods of Measurement of Radio-Noise Emissions from Low-Voltage Electrical and Electronic Equipment in the Range of 9 kHz to 40 GHz	2014

B.4 LABORATORY ENVIRONMENT

Semi-anechoic chamber did not exceed following limits along the EMC testing:

Temperature	Min. = 15 °C, Max. = 35°C
Relative humidity	Min. = 15 %, Max. = 75 %
Shielding effectiveness	0.014MHz-1MHz,>60dB; 1MHz-18000MHz,>90dB
Electrical insulation	>2M
Ground system resistance	<4
Normalised site attenuation (NSA)	<±4 dB, 3 m distance, from 30 to 1000 MHz

Shield room did not exceed following limits along the EMC testing:

Temperature	Min. = 15 °C, Max. = 30 °C
Relative humidity	Min. =20 %, Max. = 75 %
Shielding effectiveness	0.014MHz-1MHz,>60dB; 1MHz-10000MHz,>90dB
Electrical insulation	>2M
Ground system resistance	<4

Fully-anechoic chamber did not exceed following limits along the EMC testing:

Temperature	Min. = 15 °C, Max. = 35°C
Relative humidity	Min. = 15 %, Max. = 75 %
Shielding effectiveness	0.014MHz-1MHz,>60dB; 1MHz-18000MHz,>90dB
Electrical insulation	>2M
Ground system resistance	<4
Voltage Standing Wave Ratio (VSWR)	≤ 6 dB, from 1 to 18GHz, 3 m distance
Uniformity of field strength	Between 0 and 6 dB, from 80 to 6000 MHz

B.5 SUMMARY OF TEST RESULTS

Abbreviations used in this clause:	
P	Pass
NA	Not applicable
F	Fail

Items	Test Name	Clause in FCC rules	Section in this report	Verdict
1	Radiated Emission	15.109(a)	A.1	P
2	Conducted Emission	15.107(a)	A.2	P

B.6 Test Facilities Utilized

NO.	NAME	TYPE	series number	PRODUCER	CALDUE DATE	CAL PERIOD
1	Test Receiver	ESR7	101676	R&S	2019.11.28	1 year
2	Test Receiver	ESCI	100702	R&S	2019.06.20	1 year
3	Spectrum Analyzer	FSV40	101192	R&S	2019.05.21	1 year
4	BiLog Antenna	3142E	00224831	ETS-lindgren	2021.05.17	3 years
5	LISN	ENV216	102067	R&S	2019.07.18	1 year
6	Horn Antenna	3117	00066577	ETS-lindgren	2019.04.05	3 years
7	Universal Radio Communication Tester	CMU200	114545	R&S	2019.05.17	1 year
8	PC	ThinkPad E480	PF-0Z56NV	Lenovo	/	/
9	Printer	P1008	VNF6C12491	HP	/	/
10	Mouse	MOEUJUA	44NY517	Lenovo	/	/
11	Chamber	FACT3-2.0	1285	ETS-Lindgren	2020.07.20	3 years

B.7 MEASUREMENT RESULTS

B.7.1 Radiated Emission (§ 15.109(a))

Reference

FCC: CFR Part 15.109(a)

B.7.1.1 Method of measurement

The field strength of radiated emissions from the unintentional radiator (USB mode of MS and charging mode of MS) at a distance of 3 meters is tested. Tested in accordance with the procedures of ANSI C63.4 -2014, section 8.3.

The EUT was placed on a non-conductive table. The measurement antenna was placed at a distance of 3 meters from the EUT. During the tests, the antenna height and the EUT azimuth were varied in order to identify the maximum level of emissions from the EUT. This maximization process was repeated with the EUT positioned in each of its three orthogonal orientations.

B.7.1.2 EUT Operating Mode:

Charging mode: The MS is synchronized to SS, and able to respond to paging messages and incoming call. An established call has been released. The MS is connected to a charger.

USB mode: The model of the PC is Lenovo ThinkPadE480, and the serial number of the PC is PF-0Z56NV. The CMD.exe is used to let the PC keep on ping EUT's IP address, pinging EUT's IP address was until test finished.

B.7.1.3 Measurement Limit

Limit from CFR Part 15.109(a)

Frequency range (MHz)	Field strength limit ($\mu\text{V}/\text{m}$)		
	Quasi-peak	Average	Peak
30-88	100		
88-216	150		
216-960	200		
960-1000	500		
>1000		500	5000

*Note: The original limit is defined at 10m test distance. This limit is calculated according to CISPR requirements.

B.7.1.4 Test Condition

Frequency of emission (MHz)	RBW/VBW	Sweep Time(s)
30-1000	120kHz (IF bandwidth)	5
Above 1000	1MHz/3MHz	15

B.7.1.5 Test set-up
30MHz-1GHz

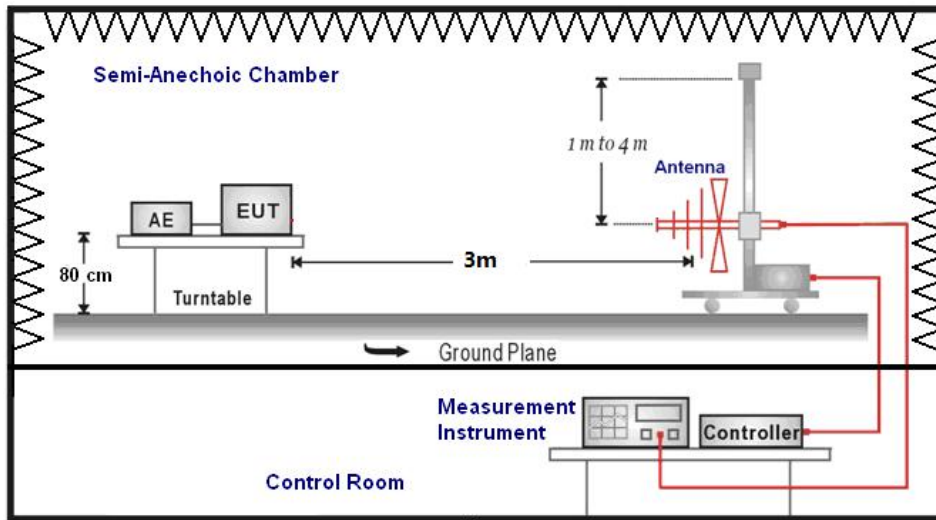

1GHz-18GHz

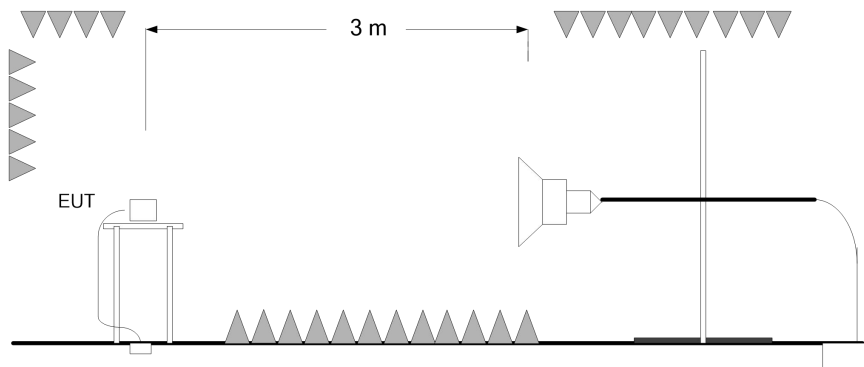

B.7.1.6 Measurement Results

A "reference path loss" is established and the A_{Rpl} is the attenuation of "reference path loss". It includes the antenna factor of receive antenna and the path loss.

The measurement results are obtained as described below:

$$\text{Result} = P_{\text{Mea}} + A_{Rpl} = P_{\text{Mea}} + G_A + G_{PL}$$

Where

G_A : Antenna factor of receive antenna

G_{PL} : Path Loss

P_{Mea} : Measurement result on receiver.

Note: the result contains vertical part and Horizontal part

RE Measurement uncertainty: 30M-1GHz: 5.12dB (k=2);

1GHz-18GHz: 5.05 dB (k=2)

Set.1 Charging mode / Peak detector

Frequency(MHz)	Result(dBuV/m)	Limit (dBμV/m)	Margin(dB)	Polarity	ARpl (dB/m)	PMea (dBμV)
12397.5	54.99	74.00	19.01	H	17.7	37.29
13440.0	55.19	74.00	18.81	V	17.9	37.29
13933.0	55.65	74.00	18.35	H	18.2	37.45
14558.5	55.25	74.00	18.75	V	19.0	36.25
15621.5	58.20	74.00	15.80	H	21.1	37.1
16636.00	58.45	74.00	15.55	V	22.8	35.65

Set.1 Charging mode / Average detector

Frequency(MHz)	Result(dBuV/m)	Limit (dBμV/m)	Margin(dB)	Polarity	ARpl (dB/m)	PMea (dBμV)
12439.5	42.46	54	11.54	H	17.9	24.56
13380.5	42.95	54	11.05	V	18	24.95
13958.5	42.74	54	11.26	H	18.1	24.64
14535.5	43.45	54	10.55	V	19	24.45
15577.0	45.1	54	8.9	V	20.8	24.3
17699.5	45.96	54	8.04	H	23.7	22.26

Set.2 Charging mode / Peak detector

Frequency(MHz)	Result(dBuV/m)	Limit (dBμV/m)	Margin(dB)	Polarity	ARpl (dB/m)	PMea (dBμV)
13392.0	55.5	74	18.5	V	18	37.5
13997.5	55.23	74	18.77	V	18	37.23
14673.5	56.53	74	17.47	H	19	37.53
16070.0	58.56	74	15.44	V	22	36.56
16615.0	58.67	74	15.33	V	23	35.67
17711.5	57.78	74	16.22	H	23.7	34.08

Set.2 Charging mode / Average detector

Frequency(MHz)	Result(dBuV/m)	Limit (dBμV/m)	Margin(dB)	Polarity	ARpl (dB/m)	PMea (dBμV)
13379.5	42.86	54	11.14	H	18	24.86
13954.5	42.7	54	11.3	V	18.1	24.6
14545.5	43.49	54	10.51	H	19	24.49
15667.0	46.35	54	7.65	H	21.3	25.05
16630.5	46.42	54	7.58	V	22.9	23.52
17696.5	45.9	54	8.1	H	23.7	22.2

Set.3 USB mode / Peak detector

Frequency(MHz)	Result(dBuV/m)	Limit (dB μ V/m)	Margin(dB)	Polarity	ARpl (dB/m)	PMea (dB μ V)
13966.5	55.9	74	18.1	H	18.1	37.8
14628.0	55.89	74	18.11	H	19	36.89
15575.0	57.08	74	16.92	V	20.8	36.28
16159.0	58.64	74	15.36	H	22.5	36.14
17052.5	58.59	74	15.41	V	22.6	35.99
17902.5	58.93	74	15.07	V	25	33.93

Set.3 USB mode / Average detector

Frequency(MHz)	Result(dBuV/m)	Limit (dB μ V/m)	Margin(dB)	Polarity	ARpl (dB/m)	PMea (dB μ V)
13957.5	42.9	54	11.1	V	18.1	24.8
14572.5	43.66	54	10.34	H	19	24.66
15573.5	44.97	54	9.03	V	20.8	24.17
15657.0	46.37	54	7.63	V	21.2	25.17
16591.5	46.56	54	7.44	V	23.1	23.46
17700.5	46.12	54	7.88	V	23.7	22.42

Charging mode: Set 1

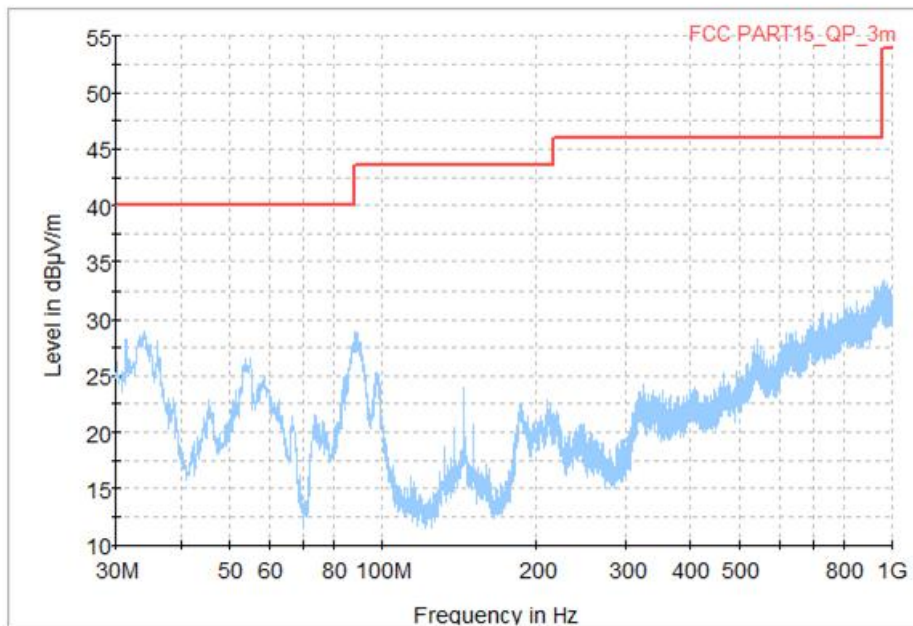

Figure B.1 Radiated Emission from 30MHz to 1GHz

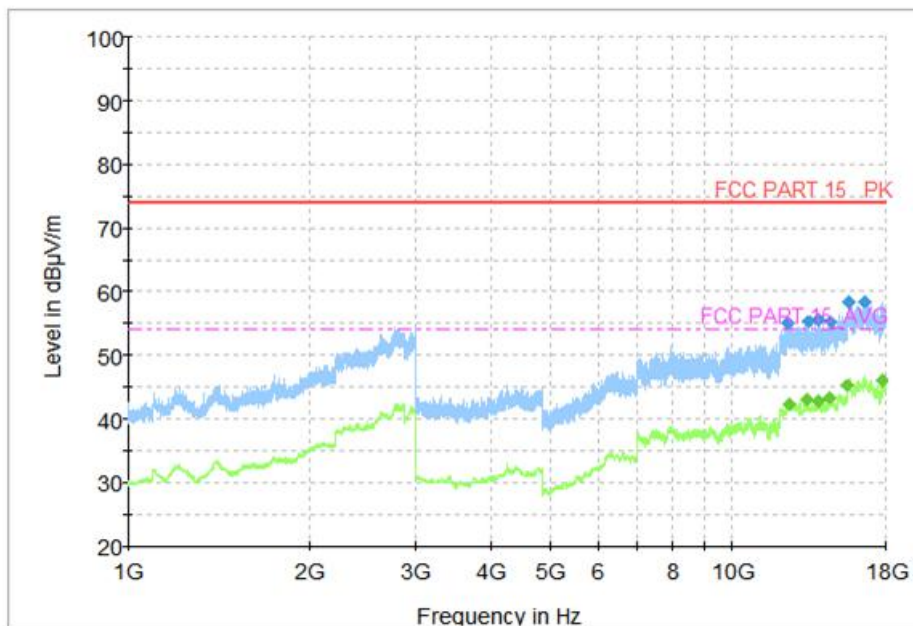

Figure B.2 Radiated Emission from 1GHz to 18GHz

Charging mode: Set 2

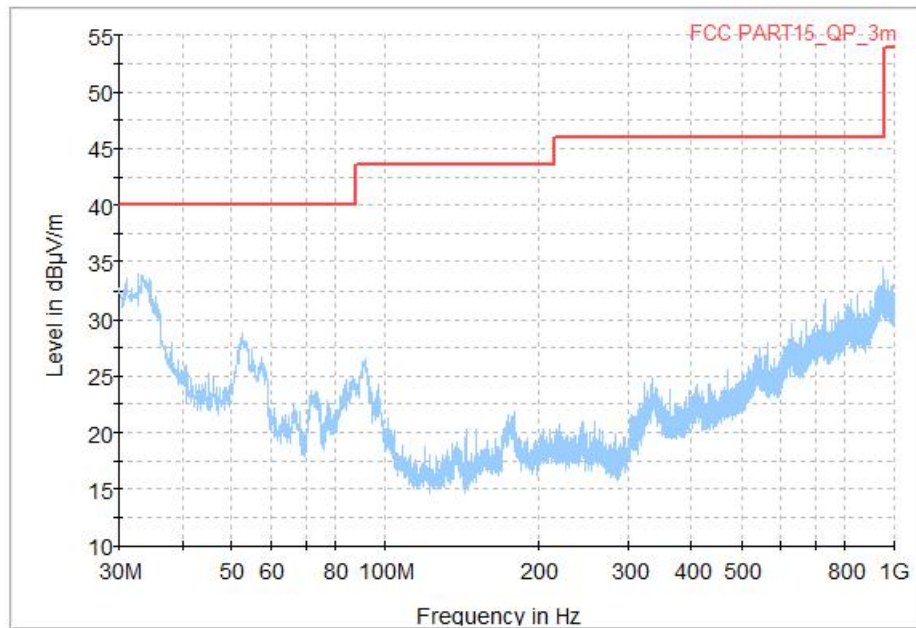

Figure B.3 Radiated Emission from 30MHz to 1GHz

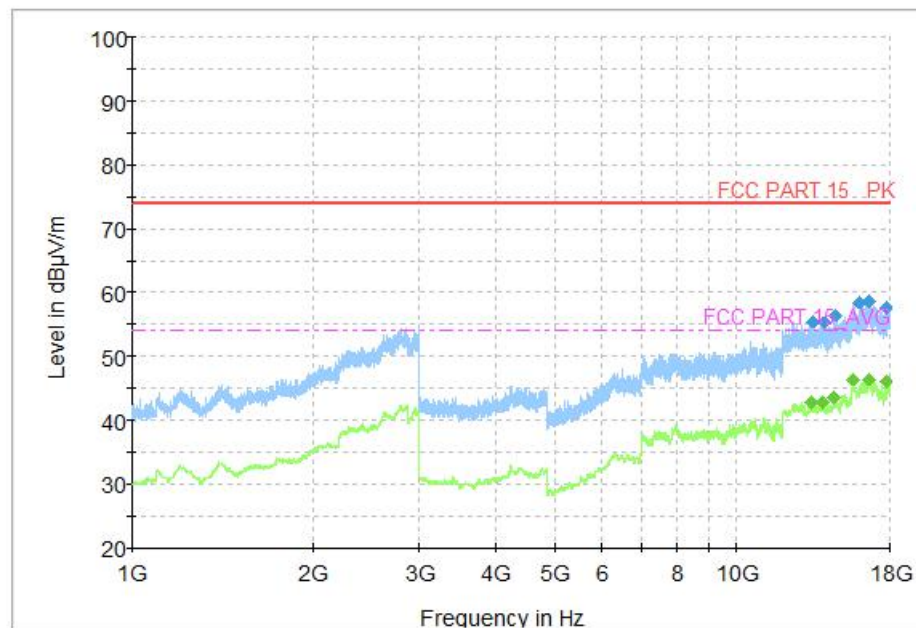

Figure B.4 Radiated Emission from 1GHz to 18GHz

USB mode: Set 3

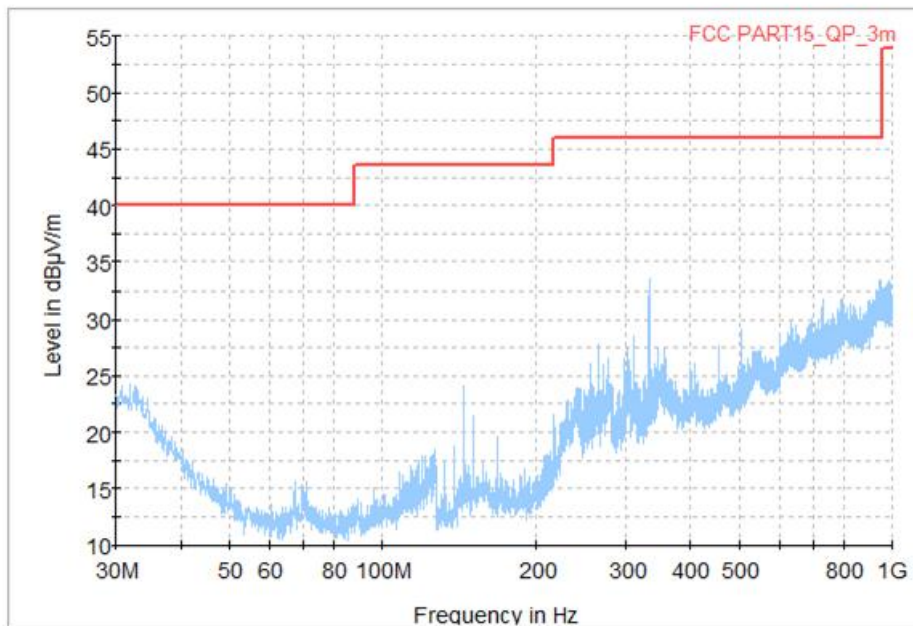

Figure B.5 Radiated Emission from 30MHz to 1GHz

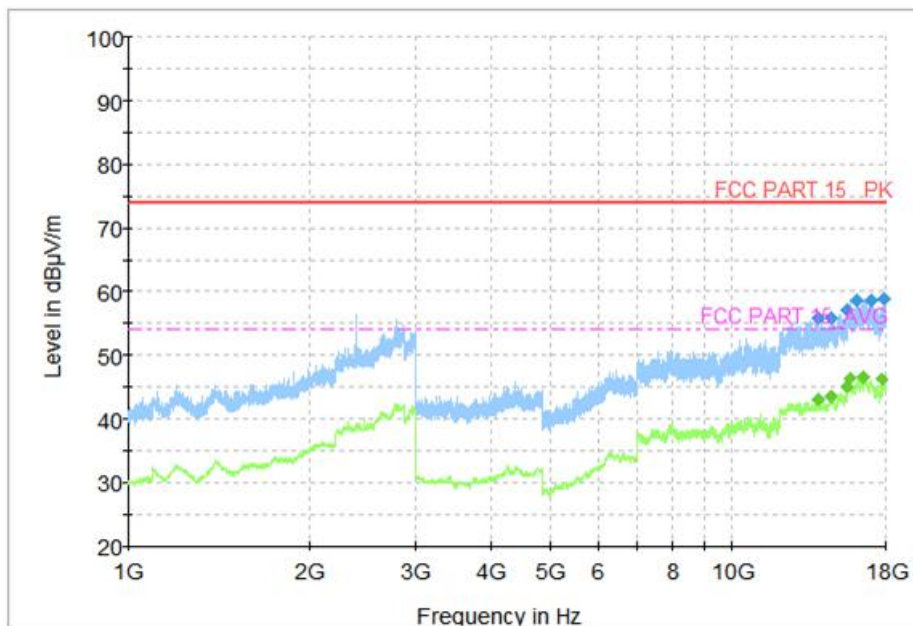

Figure B.6 Radiated Emission from 1GHz to 18GHz

B.7.2 Conducted Emission (§ 15.107(a))

Reference

FCC: CFR Part 15.107(a)

B.7.2.1 Method of measurement

For equipment that is designed to be connected to the public utility (AC) power line, the radio frequency voltage that is conducted back onto the AC power line on any frequency or frequencies within the band 150kHz to 30MHz shall not exceed the limits. Tested in accordance with the procedures of ANSI C63.4 -2014, section 7.3.

B.7.2.2 EUT Operating Mode:

Charging mode: The MS is synchronized to SS, and able to respond to paging messages and incoming call. An established call has been released. The MS is connected to a charger.

USB mode: The model of the PC is Lenovo ThinkPadE480, and the serial number of the PC is PF-0Z56NV. The CMD.exe is used to let the PC keep on ping EUT's IP address, pinging EUT's IP address was until test finished.

B.7.2.3 Measurement Limit

Frequency of emission (MHz)	Conducted limit (dBµV)	
	Quasi-peak	Average
0.15-0.5	66 to 56*	56 to 46*
0.5-5	56	46
5-30	60	50

*Decreases with the logarithm of the frequency

B.7.2.4 Test set-up:

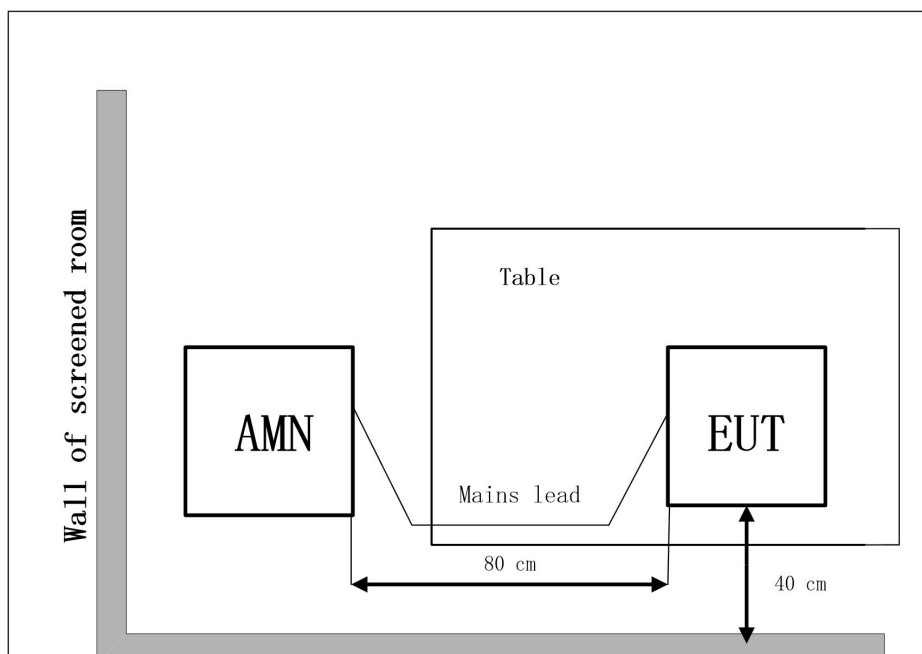

B.7.2.5 Test Condition in charging mode

Voltage (V)	Frequency (Hz)
120	50
240	50

RBW	Sweep Time(s)
9kHz	1

CE Measurement uncertainty: 3.10 dB (k=2)

B.7.2.6 Measurement Results

QuasiPeak(dBμV) /Average(dBμV) =P_{Mea}+Corr

Where

Corr: PathLoss + Voltage Division Factor

P_{Mea}: Measurement result on receiver.

Charging mode: Set 1
Voltage: 120V

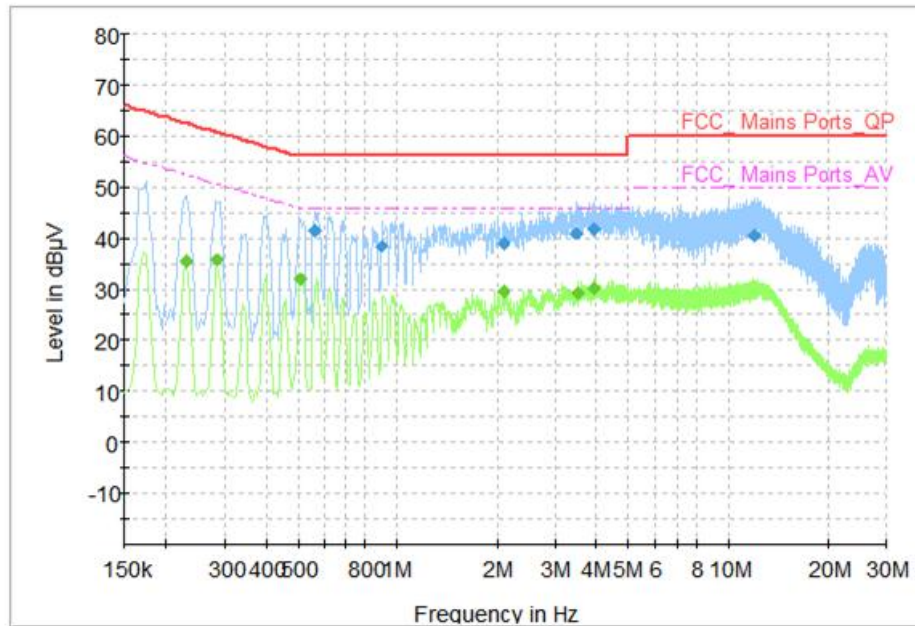

Figure B.1 Conducted Emission

Final Measurement Detector 1

Frequency (MHz)	Average (dBµV)	Limit (dBµV)	Margin (dB)	Line	Corr. (dB)	PMea (dBµV)
0.562	41.34	56	14.66	L1	9.7	31.64
0.898	38.37	56	17.63	L1	9.7	28.67
2.086	38.96	56	17.04	L1	9.7	29.26
3.470	40.91	56	15.09	N	9.7	31.21
3.946	41.82	56	14.18	N	9.7	32.12
11.934	40.48	60	19.52	N	9.9	30.58

Final Measurement Detector 2

Frequency (MHz)	Average (dBµV)	Limit (dBµV)	Margin (dB)	Line	Corr. (dB)	PMea (dBµV)
0.230	35.31	52.45	17.14	N	9.6	25.71
0.286	35.67	50.64	14.97	N	9.6	26.07
0.510	31.94	46	14.06	N	9.7	22.24
2.086	29.58	46	16.42	L1	9.7	19.88
3.530	29.24	46	16.76	N	9.7	19.54
3.938	30.15	46	15.85	N	9.7	20.45

Charging mode: Set 2
Voltage: 120V

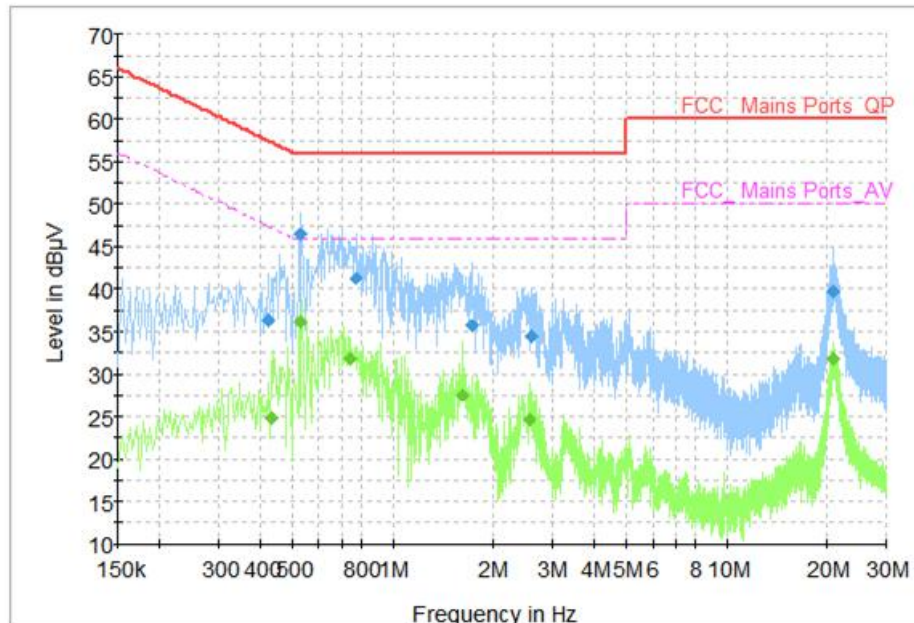

Figure B.2 Conducted Emission

Final Measurement Detector 1

Frequency (MHz)	Average (dBµV)	Limit (dBµV)	Margin (dB)	Line	Corr. (dB)	PMea (dBµV)
0.422	36.28	57.41	21.13	N	9.7	26.58
0.530	46.43	56	9.57	N	9.7	36.73
0.774	41.29	56	14.71	N	9.7	31.59
1.730	35.63	56	20.37	N	9.7	25.93
2.602	34.54	56	21.46	N	9.7	24.84
20.946	39.84	60	20.16	N	10.4	29.44

Final Measurement Detector 2

Frequency (MHz)	Average (dBµV)	Limit (dBµV)	Margin (dB)	Line	Corr. (dB)	PMea (dBµV)
0.430	24.84	47.25	22.41	N	9.7	15.14
0.530	36.09	46	9.91	N	9.7	26.39
0.746	31.8	46	14.2	N	9.7	22.1
1.610	27.47	46	18.53	N	9.7	17.77
2.566	24.68	46	21.32	N	9.7	14.98
20.894	31.77	50	18.23	N	10.4	21.37

USB mode: Set 3
Voltage: 120V

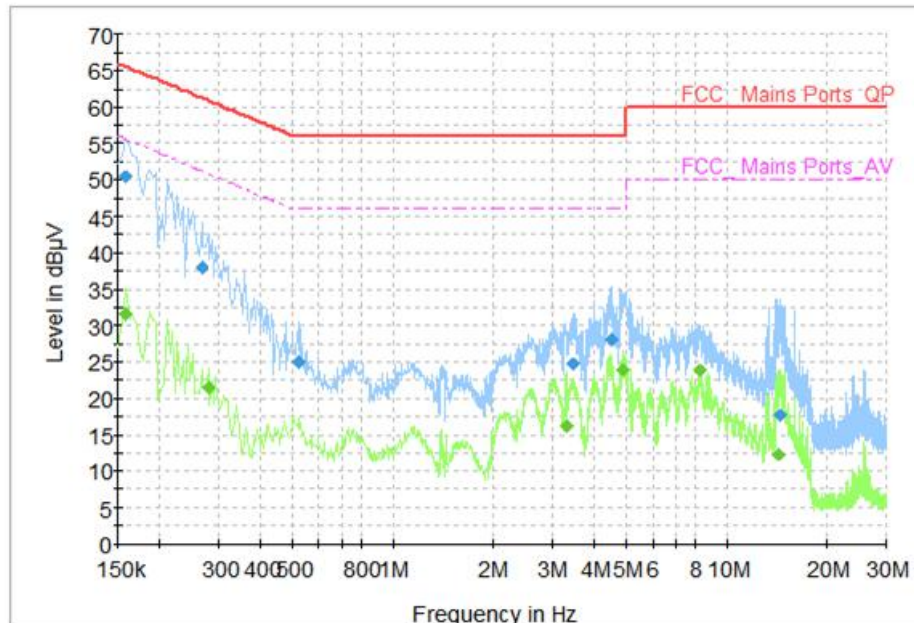

Figure B.3 Conducted Emission

Final Measurement Detector 1

Frequency (MHz)	Average (dBµV)	Limit (dBµV)	Margin (dB)	Line	Corr. (dB)	PMea (dBµV)
0.158	50.43	65.57	15.14	N	9.6	40.83
0.266	37.83	61.24	23.41	N	9.6	28.23
0.522	25.05	56	30.95	N	9.7	15.35
3.446	24.62	56	31.38	N	9.7	14.92
4.506	28.11	46	21.32	L1	9.8	14.98
14.382	17.67	60	42.33	N	9.9	7.77

Final Measurement Detector 2

Frequency (MHz)	Average (dBµV)	Limit (dBµV)	Margin (dB)	Line	Corr. (dB)	PMea (dBµV)
0.158	31.62	55.57	23.95	N	9.6	22.02
0.278	21.54	50.88	29.34	N	9.6	11.94
3.290	16.17	46	29.83	N	9.7	6.47
4.874	23.91	46	22.09	N	9.7	14.21
8.310	23.72	50	26.28	N	9.8	13.92
14.282	12.26	50	37.74	N	9.9	2.36

Charging mode: Set 1
Voltage: 240V

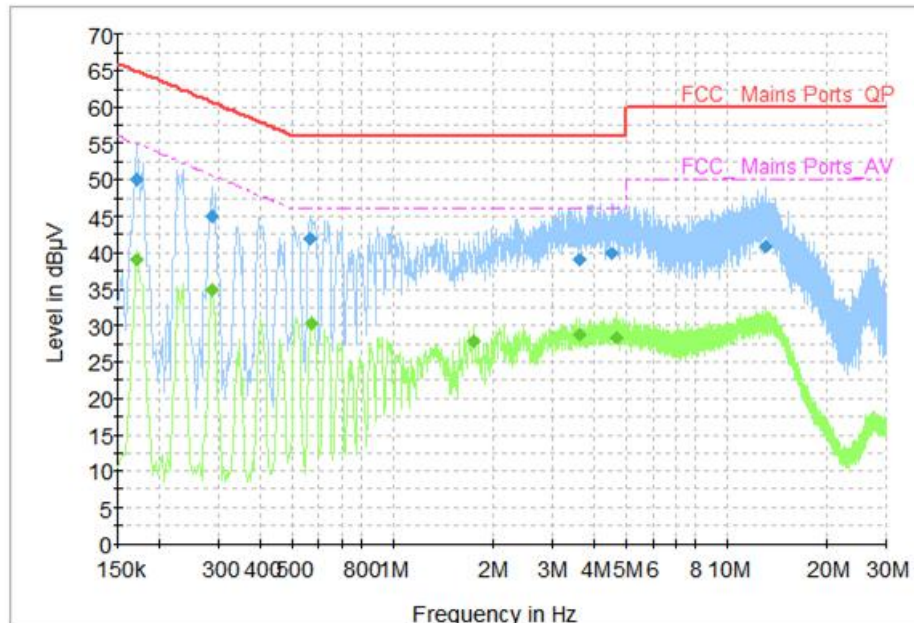

Figure B.4 Conducted Emission

Final Measurement Detector 1

Frequency (MHz)	Average (dBµV)	Limit (dBµV)	Margin (dB)	Line	Corr. (dB)	PMea (dBµV)
0.170	50.05	64.96	14.91	N	9.6	40.45
0.286	44.95	60.64	15.69	N	9.6	35.35
0.562	41.89	56	14.11	L1	9.7	32.19
3.602	39.01	56	16.99	N	9.7	29.31
4.506	39.83	56	16.17	N	9.7	30.13
12.994	40.98	60	19.02	N	9.9	31.08

Final Measurement Detector 2

Frequency (MHz)	Average (dBµV)	Limit (dBµV)	Margin (dB)	Line	Corr. (dB)	PMea (dBµV)
0.170	39.01	54.96	15.95	N	9.6	29.41
0.286	34.99	50.64	15.65	N	9.6	25.39
0.570	30.33	46	15.67	N	9.7	20.63
1.746	27.84	46	18.16	L1	9.7	18.14
3.602	28.77	46	17.23	N	9.7	19.07
4.654	28.48	46	17.52	N	9.7	18.78

Charging mode: Set 2
Voltage: 240V

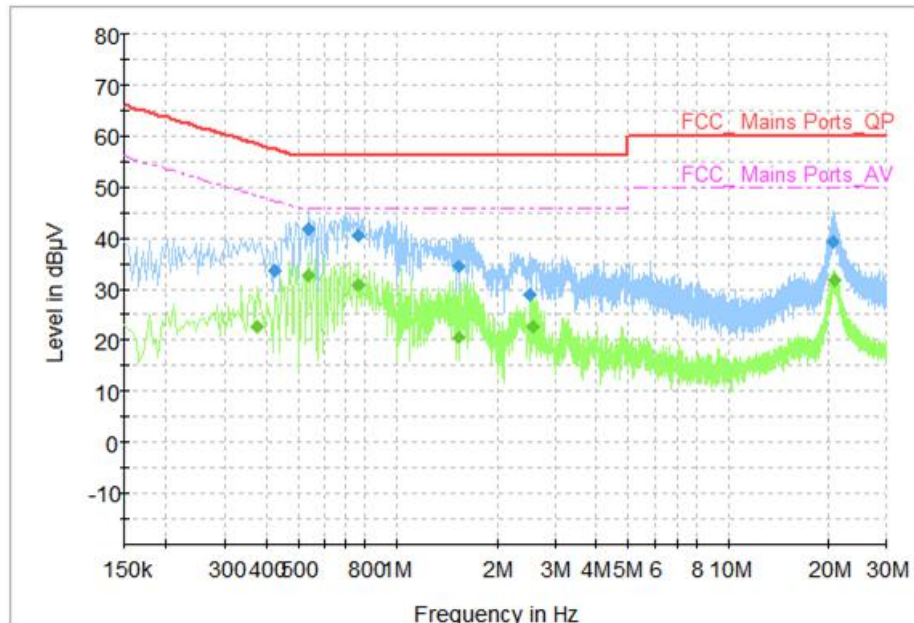

Figure B.5 Conducted Emission

Final Measurement Detector 1

Frequency (MHz)	Average (dBµV)	Limit (dBµV)	Margin (dB)	Line	Corr. (dB)	PMea (dBµV)
0.426	33.68	57.33	23.65	L1	9.7	23.98
0.538	41.83	56	14.17	N	9.7	32.13
0.762	40.56	56	15.44	N	9.7	30.86
1.526	34.46	56	21.54	N	9.7	24.76
2.522	28.98	56	27.02	L1	9.7	19.28
20.594	39.16	60	20.84	N	10.4	28.76

Final Measurement Detector 2

Frequency (MHz)	Average (dBµV)	Limit (dBµV)	Margin (dB)	Line	Corr. (dB)	PMea (dBµV)
0.378	22.59	48.32	25.73	N	9.6	12.99
0.538	32.61	46	13.39	N	9.7	22.91
0.762	30.96	46	15.04	N	9.7	21.26
1.526	20.58	46	25.42	N	9.7	10.88
2.574	22.69	46	23.31	N	9.7	12.99
20.906	31.71	50	18.29	N	10.4	21.31

USB mode: Set 3
Voltage: 240V

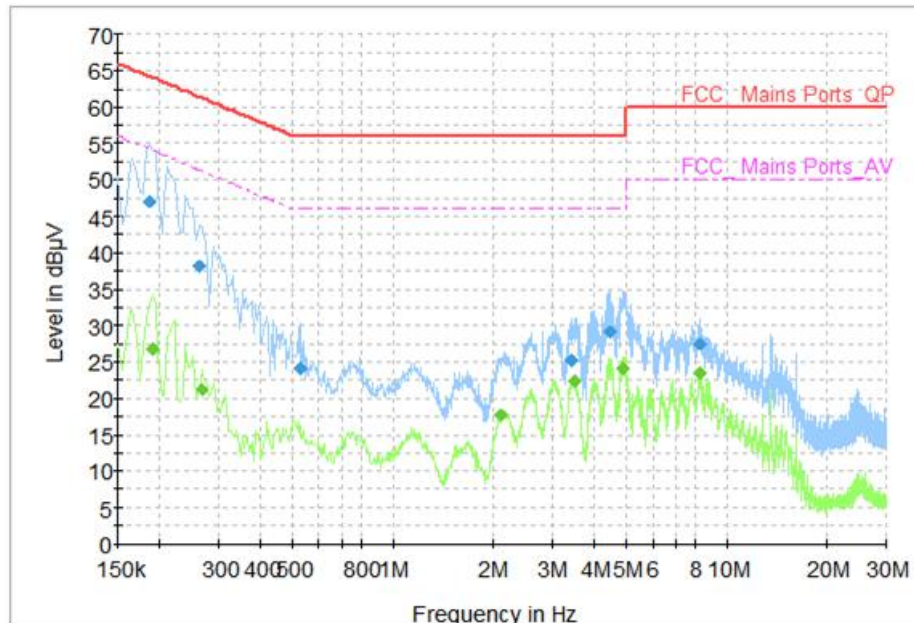

Figure B.6 Conducted Emission

Final Measurement Detector 1

Frequency (MHz)	Average (dBµV)	Limit (dBµV)	Margin (dB)	Line	Corr. (dB)	PMea (dBµV)
0.186	47.1	64.21	17.12	L1	9.7	37.4
0.262	38.15	61.37	23.21	L1	9.7	28.45
0.530	24.11	56	31.89	N	9.7	14.41
3.434	25.19	56	30.81	N	9.7	15.49
4.458	29.11	56	26.89	N	9.7	19.41
8.282	27.59	60	32.41	N	9.8	17.79

Final Measurement Detector 2

Frequency (MHz)	Average (dBµV)	Limit (dBµV)	Margin (dB)	Line	Corr. (dB)	PMea (dBµV)
0.190	26.83	54.04	27.21	L1	9.7	17.13
0.266	21.08	51.24	30.16	N	9.6	11.48
2.094	17.57	46	28.43	N	9.7	7.87
3.486	22.46	46	23.54	N	9.7	12.76
4.898	24.15	46	21.85	N	9.7	14.45
8.314	23.43	50	26.57	N	9.8	13.63