

BLOCK DIAGRAM

Revision Record			
No.	Date	Revised by	Remarks

D

D

C

C

B

B

A

A

Title & No			
UNSP230_A_CS_A_SCH_V0.1.0			
Revision No.			

Revised by	Date	Revised by	Date

--	--	--	--

--	--	--	--

--	--	--	--

--	--	--	--

RF BLOCK DIAGRAM

REVISION HISTORY			
REV.	DESCRIPTION	DATE	BY

D
C
B
A

D
C
B
A

TITLE & REV.	
DESCRIPTION NO.	
DESIGNER	DATE
DRAWN	DATE
APPROVED	DATE
COMPANY NAME	
UNISOC	
CONFIDENTIAL AND PROPRIETARY	

REV	DATE	DESCRIPTION	BY

PMU_ANALOG

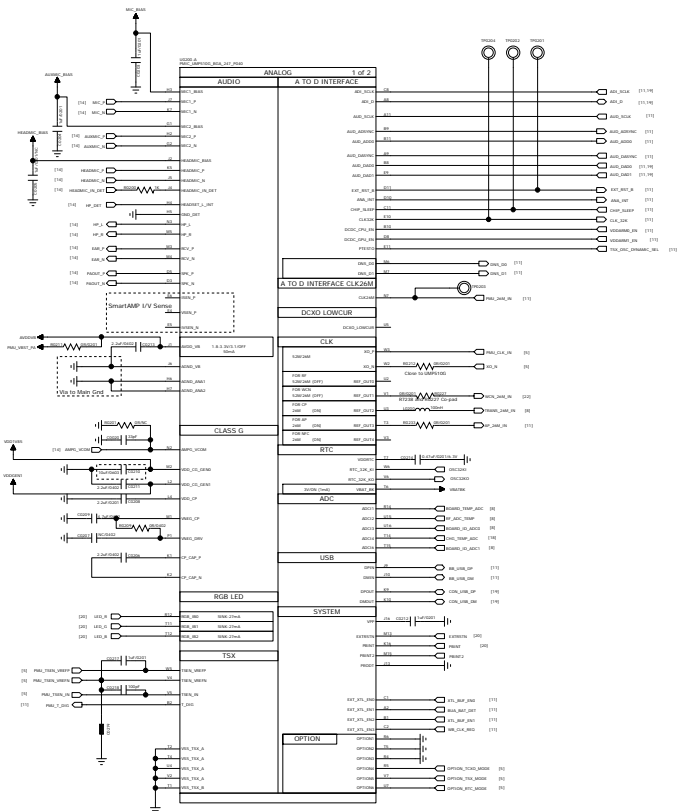

	R0211
1/D	1/C
2/K	0/R

BKBT



TSX (PMU) Only

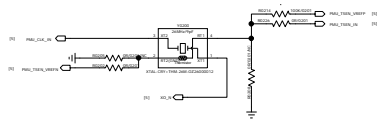

Clock solution	Y0200	X0200	R0227	R0213	R0215	R0205	R0203	R0214	R0226	R0208
TSX (PMU) Only	TSX	NF	OR	NF	OR	NF	OR	100K	OR	NF
TCXO (WGN) + DCXO (PMU)	DCXO	NF	NF	NF	OR	OR	NF	NF	NF	OR

OPTION

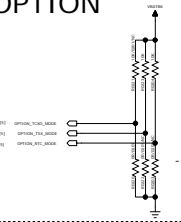

Scenario	Option3(DMFSM)	Option4(TCXO_MODEL)	Option5(TSX_MODEL)	Option6(RTC_MODEL)
26M TCXO + 32K Crystal	0	1	0	0
26M TSX + 32K Crystal	0	0	1	0
26M TSX + 32K-less from PMIC internal	0	0	1	1
26M DCXO + 32K-less from PMIC internal	0	1	1	1
26M DCXO + 32K Crystal	0	1	1	0

PMU_POWER

R007	R008	R009	R010	R011	R012	R013	R014	R015	R016	R017
OR	OR	OR	OR	OR	OR	OR	OR	OR	OR	OR
15M	2.2M	10M	10M	10M	10M	10M	10M	10M	10M	10M
NC	NC	NC	NC	NC	NC	NC	NC	NC	NC	NC

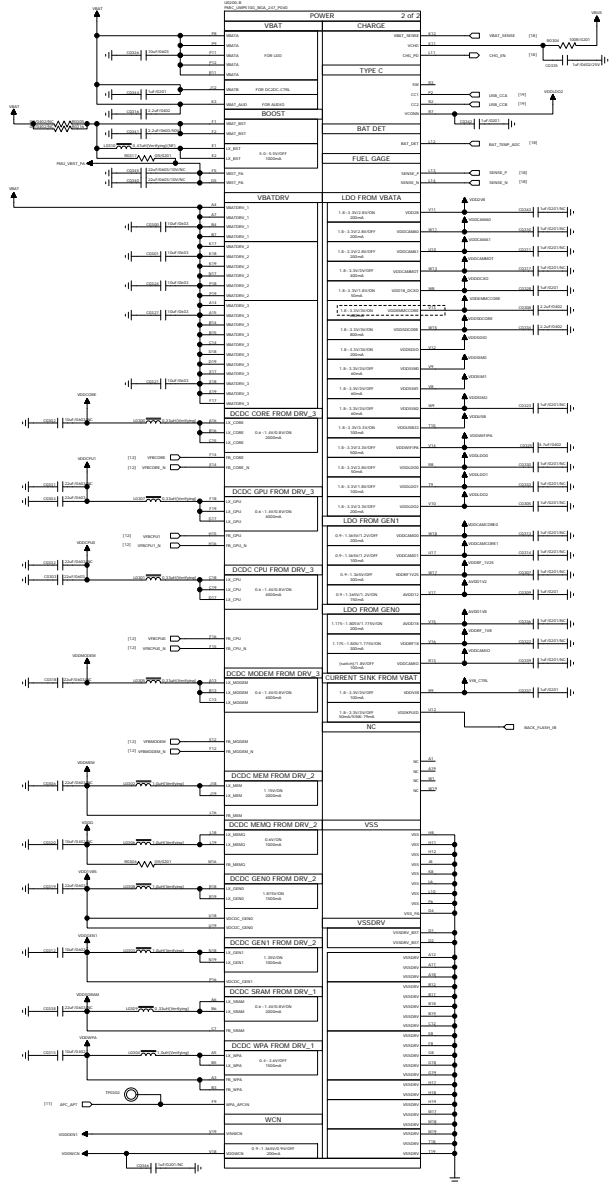

PMIC PN	PMIC VDDMEMCCORE
UMPS10G	3.0V400mA

Memory	LFS VCC	LFS VCCD	LFS VCCD2
LFS2 X Device	PMIC VDDMEMCCORE 3.0V(Back up external LDO or DCDC)	Not Used	PMIC VDD1V85

Note: If LFS VCC is greater than 600mA, please use external LDO or DCDC.

UMP510G DCDC output

Input Power	Power Name	Output Voltage (V)	Output Current (mA)	Default Voltage (V)	Default
VBAT	DCDC CORE	0.3-1.3	2000	0.8	ON
	DCDC GPU	0.3-1.3	4000	0.8	ON
	DCDC CPU	0.3-1.3	4000	0.8	ON
	DCDC MODEM	0.3-1.3	4000	0.8	ON
	DCDC MEM	0.25-1.25	2000	1.15	ON
	DCDC MEMQ	0.25-1.25	1000	0.6	ON
	DCDC GEN0	1.8-2.5	1500	1.85	ON
	DCDC GEN1	0.6-1.5	1000	1.3	ON
	DCDC SRAM	0.3-1.3	2000	0.8	ON
	DCDC WPA	0.6-3.3	1500	/	OFF

UMP510G LDO output

Input Power	Power Name	Output Voltage (V)	Output Current (mA)	Default Voltage (V)	Default
VBAT	VDD28	1.8-3.3	200	2.8	ON
	VDDCAMA0	1.8-3.3	200	2.8	OFF
	VDDCAMA1	1.8-3.3	200	2.8	OFF
	VDDCAMMOT	1.8-3.3	400	3	OFF
	VDD18_DCXO	1.8-3.3	50	1.8	ON
	VDDMEMCCORE	1.8-3.3	600	3	ON
	VDDSDCORE	1.8-3.3	800	3	ON
	VDDSDIO	1.8-3.3	200	3	ON
	VDDSIM0	1.8-3.3	60	3	OFF
	VDDSIM1	1.8-3.3	60	3	OFF
	VDDSIM2	1.8-3.3	60	3	OFF
	VDDUSB33	1.8-3.3	100	3.3	ON
	VDDWIFIPA	1.8-3.3	500	3.3	OFF
	VDDLDO0	1.8-3.3	50	2.8	OFF
	VDDLDO1	1.8-3.3	100	3.3	OFF
VDDLDO2	1.8-3.3	200	3.3	OFF	
GEN1	VDDCAMD0	1.0-1.25	400	1.1	OFF
	VDDCAMD1	1.0-1.25	200	1.1	OFF
	VDDRF1V25	1.0-1.25	300	1.25	OFF
GEN0	AVDD12	1.0-1.25	150	1.2	ON
	AVDD18	1.2-1.8	200	1.8	ON
GEN1	VDDRF18	1.2-1.8	300	1.8	ON
	VDDCAMIO	1.2-1.8	100	1.8	OFF
GEN1	WCN	1.0-1.6	200	1	OFF

Title & Rev		Revision History	
Description		Hardware DEPT	
Date		Spreadtrum communications, Inc.	
Approved		C:\SPRINGER\DESIGN\HW\HW	

eMMC + LPDDR4/eMMC + LPDDR4X/UFS+LPDDR4X(Only support UFS2.X)

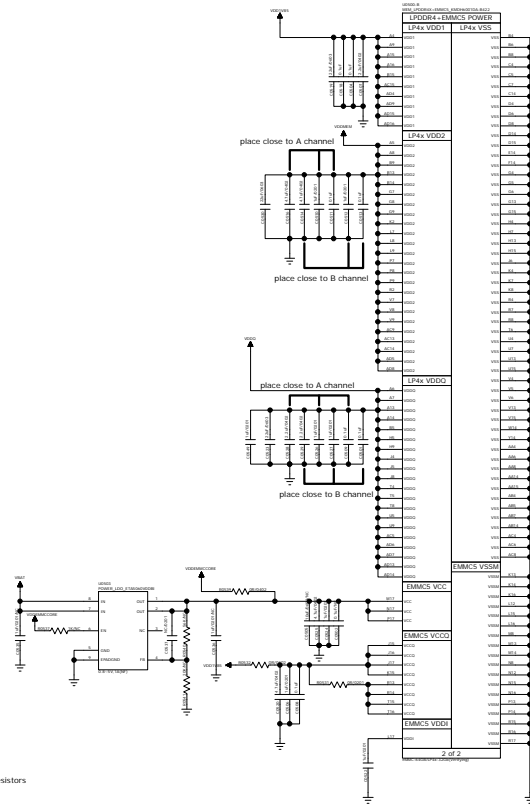
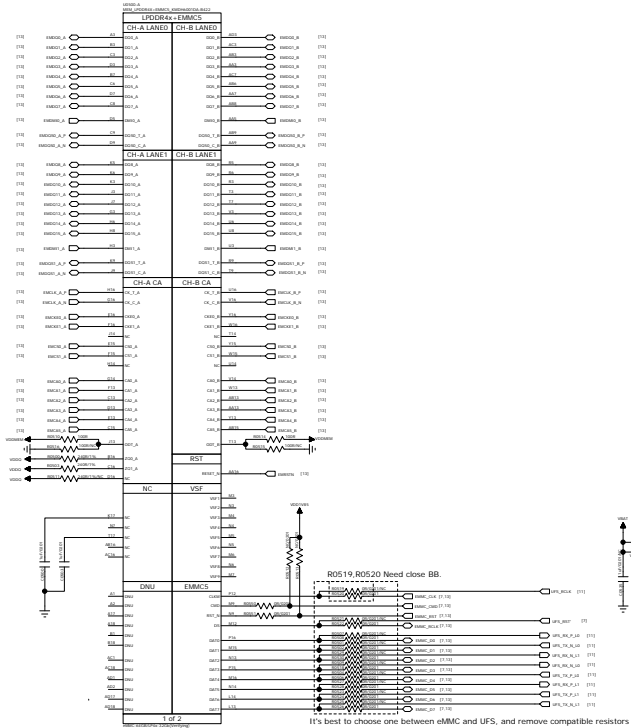

PMIC FN	PMIC VDD5B/MC0CORE	UFS VCC0	UFS VCC02
UFS110G	3.0V/600mA	PMIC VDD1V65	PMIC VDD1V65
Memory	UFS VCC	PMIC VDD1V65	PMIC VDD1V65
eMMC Device	PMIC VDD5B/MC0CORE 3.0V/Back up external LDO or DCDC	PMIC VDD1V65	PMIC VDD1V65
UFS2.X Device	PMIC VDD5B/MC0CORE 3.0V/Back up external LDO or DCDC	PMIC VDD1V65	PMIC VDD1V65

Notes: If UFS VCC is greater than 600mA, please use external LDO or DCDC.

Discrete eMMC

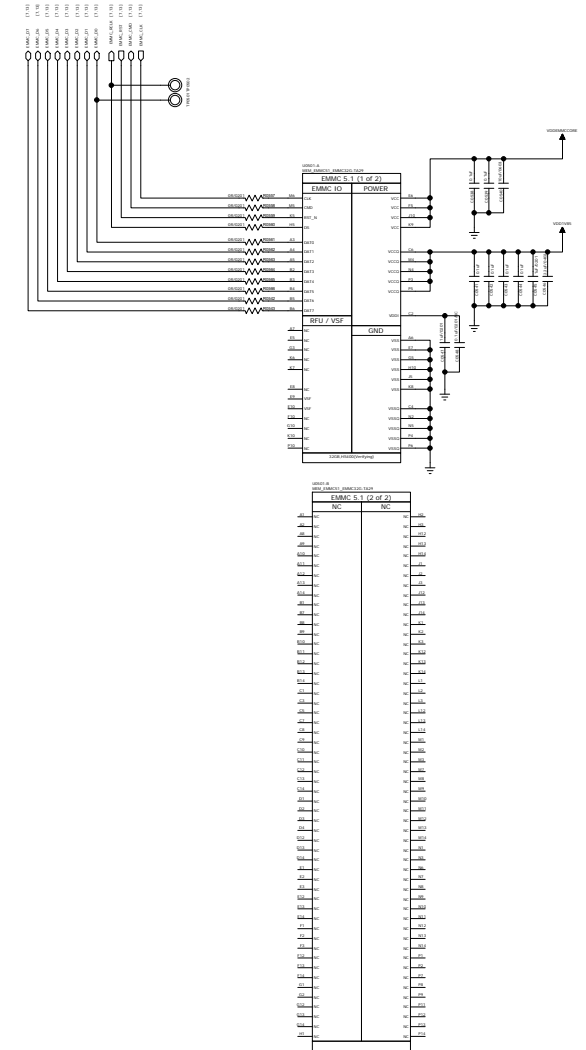

REVISION	DATE	DESCRIPTION
1.0	2023-10-27	Hardware DEPT
2.0	2023-10-27	Hardware DEPT
3.0	2023-10-27	Hardware DEPT
4.0	2023-10-27	Hardware DEPT
5.0	2023-10-27	Hardware DEPT
6.0	2023-10-27	Hardware DEPT
7.0	2023-10-27	Hardware DEPT
8.0	2023-10-27	Hardware DEPT
9.0	2023-10-27	Hardware DEPT
10.0	2023-10-27	Hardware DEPT
11.0	2023-10-27	Hardware DEPT
12.0	2023-10-27	Hardware DEPT
13.0	2023-10-27	Hardware DEPT
14.0	2023-10-27	Hardware DEPT
15.0	2023-10-27	Hardware DEPT
16.0	2023-10-27	Hardware DEPT
17.0	2023-10-27	Hardware DEPT
18.0	2023-10-27	Hardware DEPT
19.0	2023-10-27	Hardware DEPT
20.0	2023-10-27	Hardware DEPT
21.0	2023-10-27	Hardware DEPT
22.0	2023-10-27	Hardware DEPT
23.0	2023-10-27	Hardware DEPT
24.0	2023-10-27	Hardware DEPT
25.0	2023-10-27	Hardware DEPT
26.0	2023-10-27	Hardware DEPT
27.0	2023-10-27	Hardware DEPT
28.0	2023-10-27	Hardware DEPT
29.0	2023-10-27	Hardware DEPT
30.0	2023-10-27	Hardware DEPT
31.0	2023-10-27	Hardware DEPT
32.0	2023-10-27	Hardware DEPT
33.0	2023-10-27	Hardware DEPT
34.0	2023-10-27	Hardware DEPT
35.0	2023-10-27	Hardware DEPT
36.0	2023-10-27	Hardware DEPT
37.0	2023-10-27	Hardware DEPT
38.0	2023-10-27	Hardware DEPT
39.0	2023-10-27	Hardware DEPT
40.0	2023-10-27	Hardware DEPT
41.0	2023-10-27	Hardware DEPT
42.0	2023-10-27	Hardware DEPT
43.0	2023-10-27	Hardware DEPT
44.0	2023-10-27	Hardware DEPT
45.0	2023-10-27	Hardware DEPT
46.0	2023-10-27	Hardware DEPT
47.0	2023-10-27	Hardware DEPT
48.0	2023-10-27	Hardware DEPT
49.0	2023-10-27	Hardware DEPT
50.0	2023-10-27	Hardware DEPT
51.0	2023-10-27	Hardware DEPT
52.0	2023-10-27	Hardware DEPT
53.0	2023-10-27	Hardware DEPT
54.0	2023-10-27	Hardware DEPT
55.0	2023-10-27	Hardware DEPT
56.0	2023-10-27	Hardware DEPT
57.0	2023-10-27	Hardware DEPT
58.0	2023-10-27	Hardware DEPT
59.0	2023-10-27	Hardware DEPT
60.0	2023-10-27	Hardware DEPT
61.0	2023-10-27	Hardware DEPT
62.0	2023-10-27	Hardware DEPT
63.0	2023-10-27	Hardware DEPT
64.0	2023-10-27	Hardware DEPT
65.0	2023-10-27	Hardware DEPT
66.0	2023-10-27	Hardware DEPT
67.0	2023-10-27	Hardware DEPT
68.0	2023-10-27	Hardware DEPT
69.0	2023-10-27	Hardware DEPT
70.0	2023-10-27	Hardware DEPT
71.0	2023-10-27	Hardware DEPT
72.0	2023-10-27	Hardware DEPT
73.0	2023-10-27	Hardware DEPT
74.0	2023-10-27	Hardware DEPT
75.0	2023-10-27	Hardware DEPT
76.0	2023-10-27	Hardware DEPT
77.0	2023-10-27	Hardware DEPT
78.0	2023-10-27	Hardware DEPT
79.0	2023-10-27	Hardware DEPT
80.0	2023-10-27	Hardware DEPT
81.0	2023-10-27	Hardware DEPT
82.0	2023-10-27	Hardware DEPT
83.0	2023-10-27	Hardware DEPT
84.0	2023-10-27	Hardware DEPT
85.0	2023-10-27	Hardware DEPT
86.0	2023-10-27	Hardware DEPT
87.0	2023-10-27	Hardware DEPT
88.0	2023-10-27	Hardware DEPT
89.0	2023-10-27	Hardware DEPT
90.0	2023-10-27	Hardware DEPT
91.0	2023-10-27	Hardware DEPT
92.0	2023-10-27	Hardware DEPT
93.0	2023-10-27	Hardware DEPT
94.0	2023-10-27	Hardware DEPT
95.0	2023-10-27	Hardware DEPT
96.0	2023-10-27	Hardware DEPT
97.0	2023-10-27	Hardware DEPT
98.0	2023-10-27	Hardware DEPT
99.0	2023-10-27	Hardware DEPT
100.0	2023-10-27	Hardware DEPT

REV	REVNO	DESCRIPTION	DATE

LTE/WCDMA PAM

PA Part
Ipp=0.7A

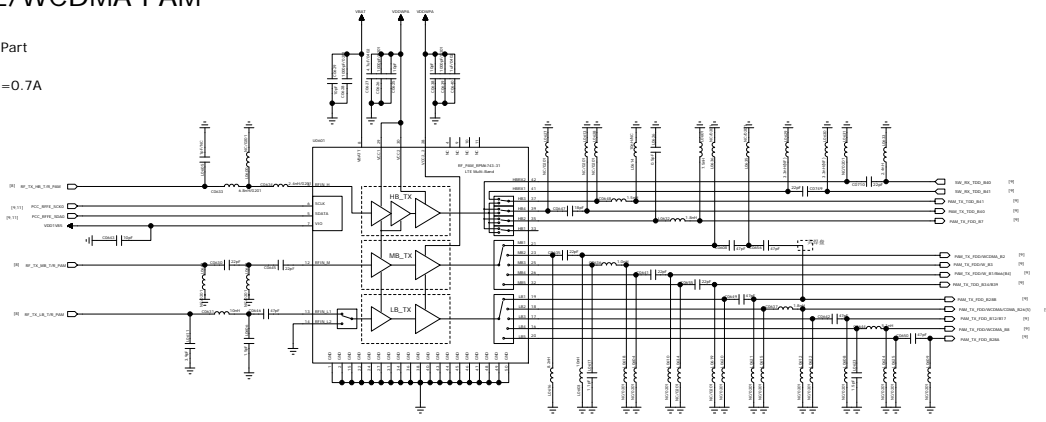

NTC

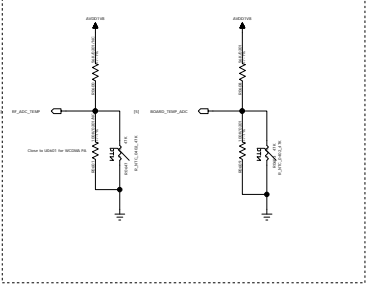

Band info/Board ID

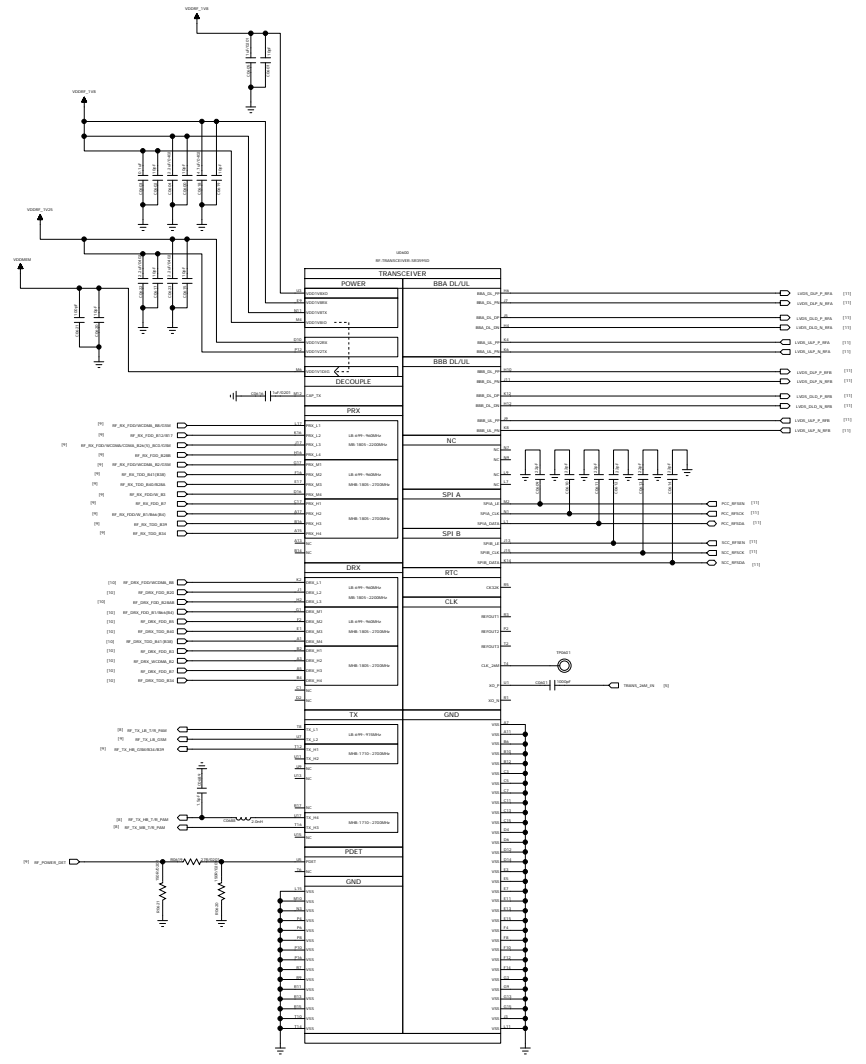
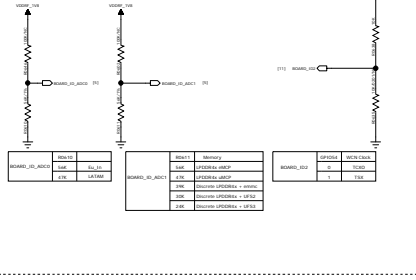

REVNO	DATE	DESCRIPTION

DESIGNER	DATE	APPROVED

DESIGNER	DATE	DESCRIPTION

DESIGNER	DATE	DESCRIPTION

Primary Antenna

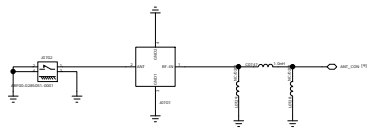

TDS/TDD B34_B39/GSM PA + Switch

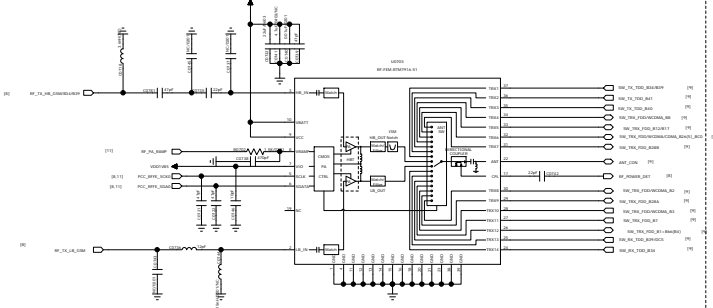

FDD LTE Parts

FDDLTE/WCDMA_B1

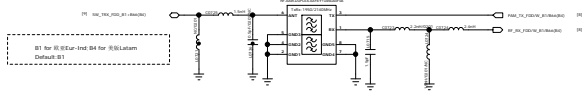

FDDLTE/WCDMA/GSM_B2

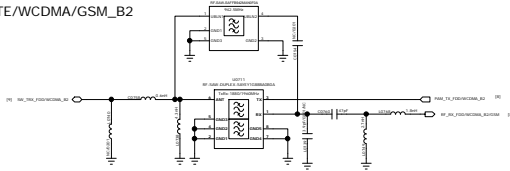

FDDLTE/WCDMA_B3

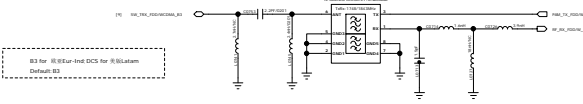

TDD LTE Parts

TDD_B34/B39 TX

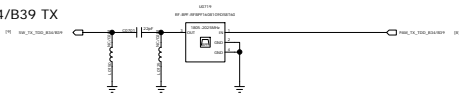

TDD_B34_RX

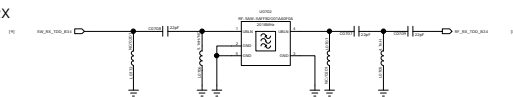

TDD_B40 TX

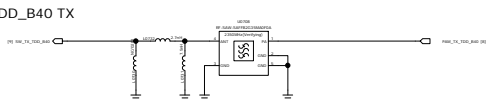

TDD_B39_RX

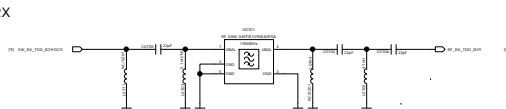

TDD_B41 TX

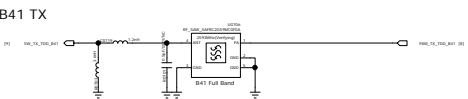

TDD_B40_RX

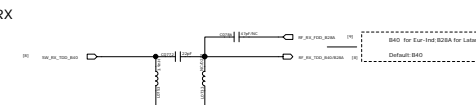

TDD_B41_RX

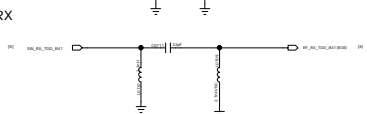

PRIMARY TRX Path FDD LTE Parts

FDDLTE/WCDMA/CDMA/GSM_B5_B26

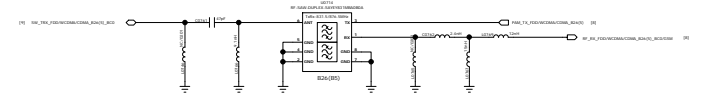

FDDLTE_B7

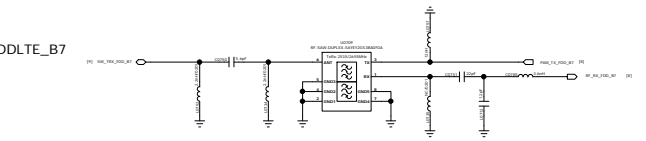

FDDLTE/WCDMA/GSM_B8

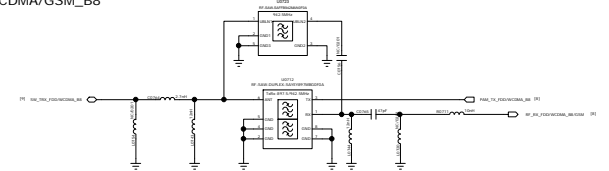

FDDLTE_B12/B17

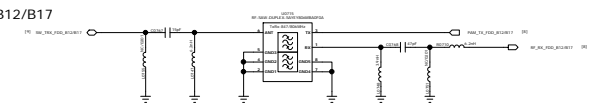

FDDLTE_B28A

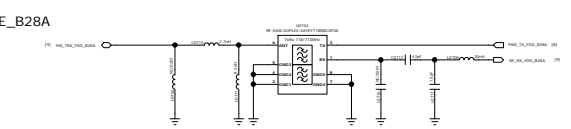

FDDLTE_B28B_B20_B3

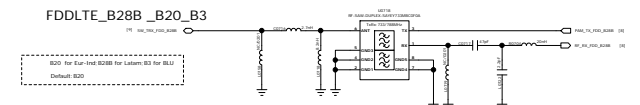

REV.	REV. NO.	DESCRIPTION	DATE

Diversity LTE Path

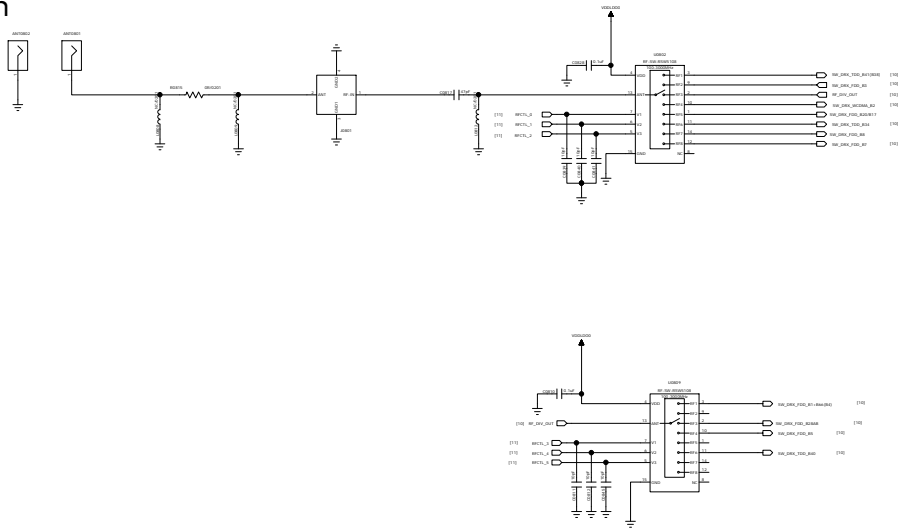

Diversity RX Path

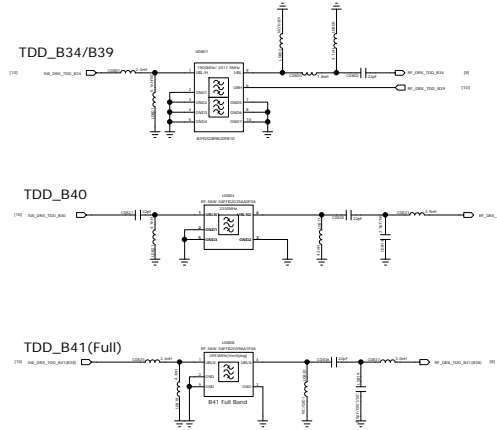

Diversity RX Path

FDD_B1+B66(B4)_Diversity RX path

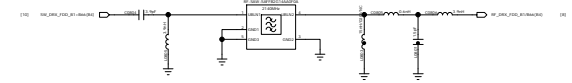

FDD_B3_Diversity RX path

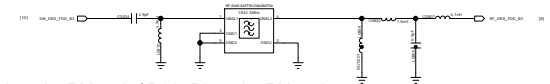

FDD_B2_Diversity RX path / B39_Diversity RX path



FDD_B5_Diversity RX path

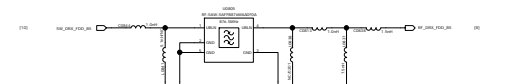

FDD_B7_Diversity Rx path

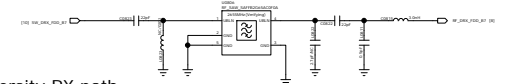

FDD_B8_Diversity RX path

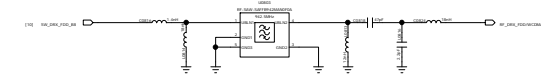

FDD_B12/B17_Diversity RX path

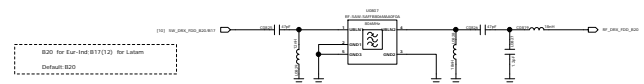

FDD_B28A/B_Diversity RX path

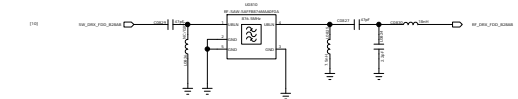

TITLE & REV.		DRAWING NO.	
DESIGNED	DATE	CHECKED	DATE
Hardware DEPT.			
SPREADTRUM COMMUNICATIONS, INC.			
CONFIDENTIAL AND PROPRIETARY			

REVISION HISTORY			
REV.	DESCRIPTION	APPROVED	DATE

MEMORY

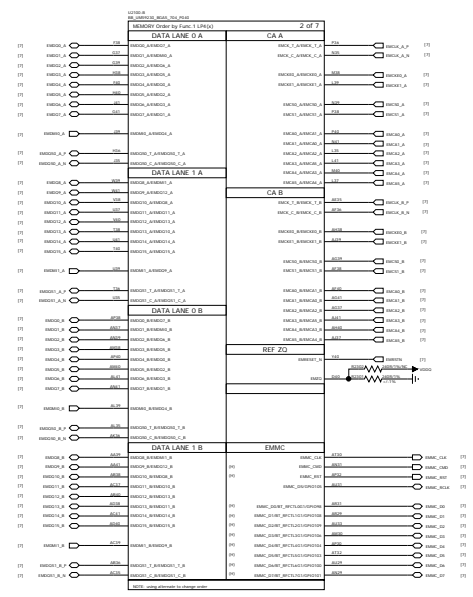

TITLE & REV			
DESCRIPTION			
DESIGNER	DATE	APPROVED	Hardware DEPT
CHK	DATE		
APPROVED	DATE		Spreadtrum communications, Inc.
CONFIDENTIAL AND PROPRIETARY			

REV	DESCRIPTION	DATE	BY

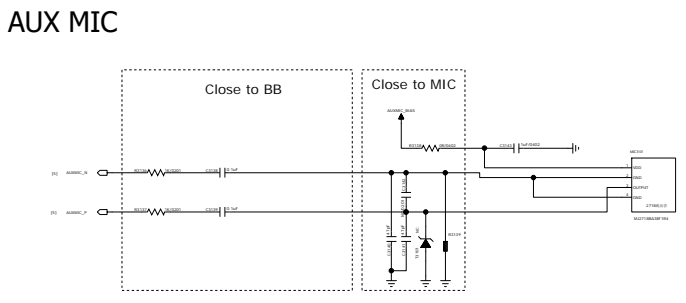
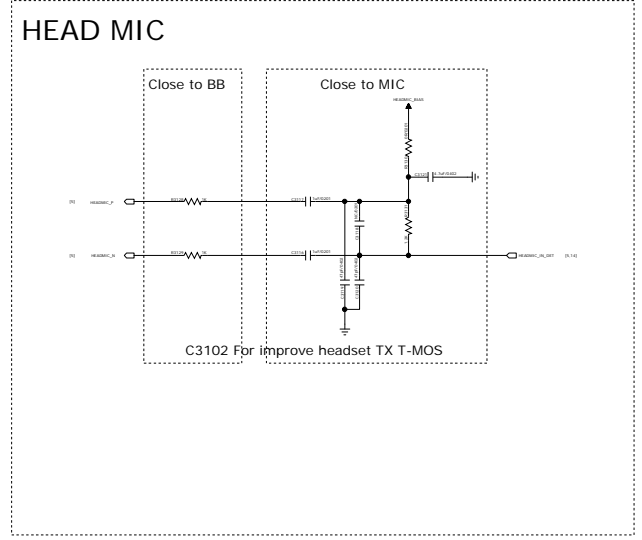
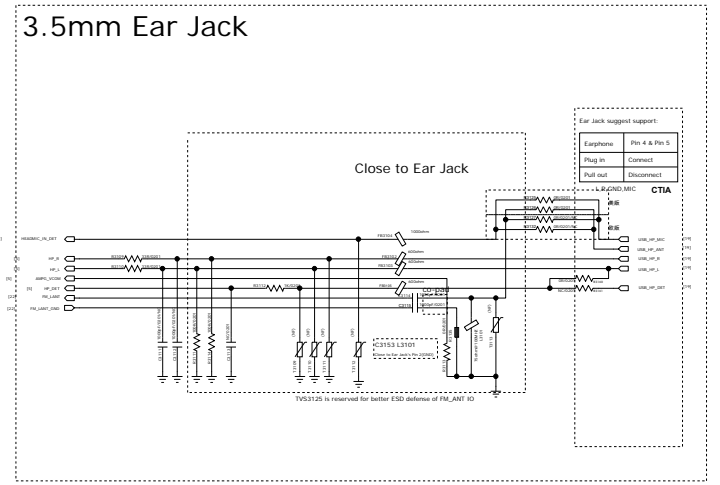
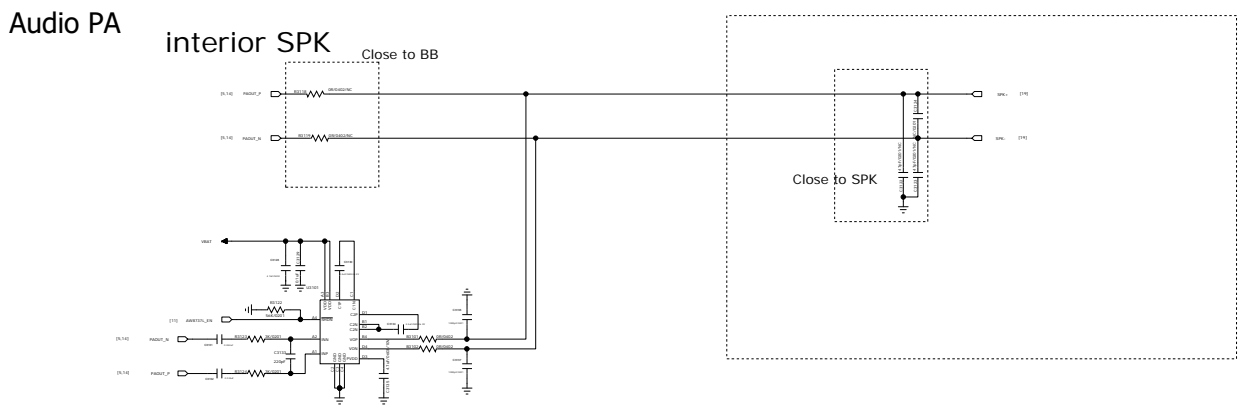
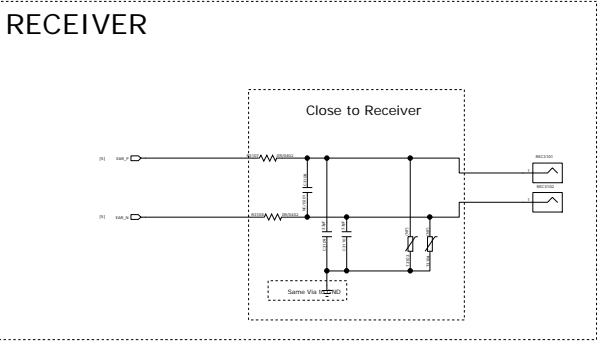
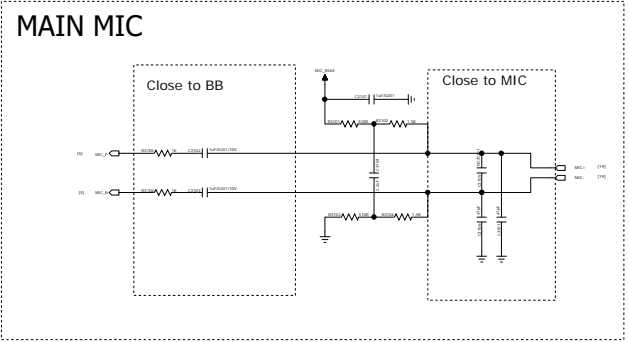

REV	DESCRIPTION	DATE	BY

REVISION	DATE	DESCRIPTION

Hardware DEPT
 Spreadtrum communications, Inc.
 CONFIDENTIAL AND PROPRIETARY

REV. RECORD			
REV.	DATE	DESCRIPTION	BY

5.99" LCM(MIPI)

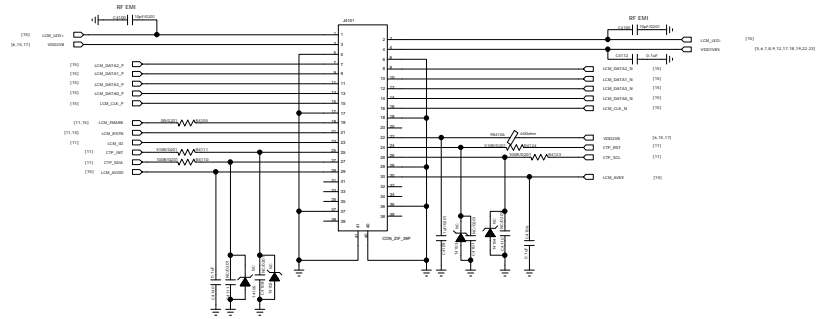
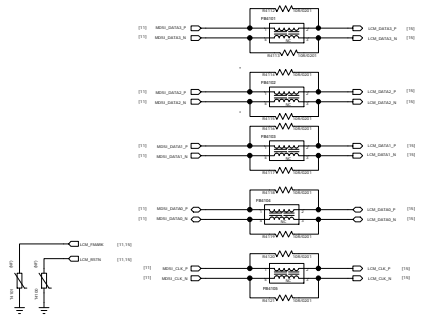

Back Light Driver

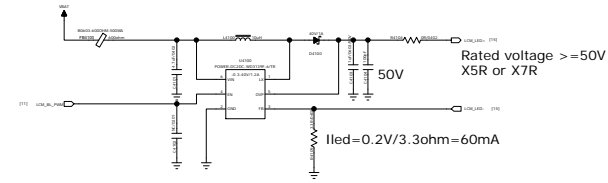

Source Driver

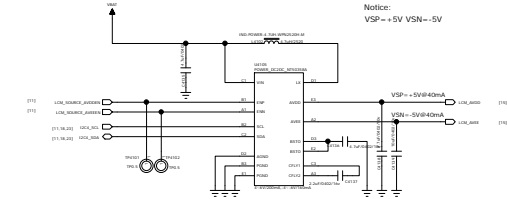

TITLE & REV.			
DESCRIPTION NO.			
DESIGNER	DATE	APPROVED	
CHK	DATE	DESIGN	
APPROVED	DATE	Spreadtrum communications, Inc.	
CONFIDENTIAL AND PROPRIETARY			

Rear Camera 0: Main 48M

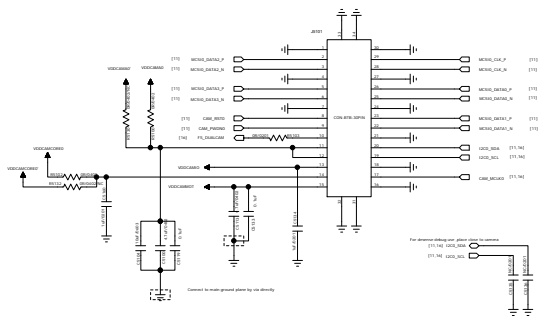

Ultra wide camera:8M

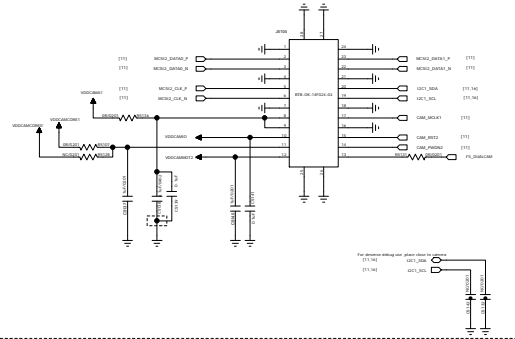

Front Camera 1:16M

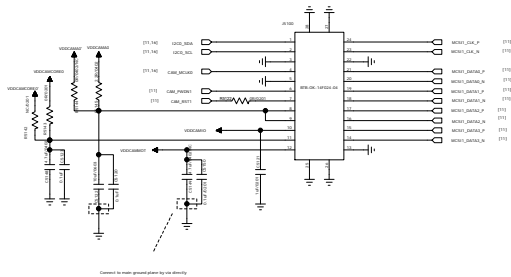

Micro distance 2M

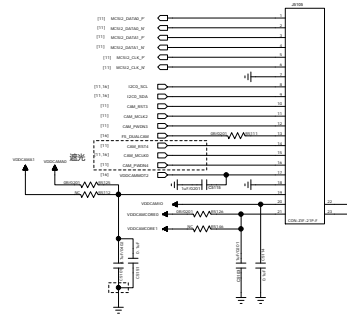

Back FLASH LED

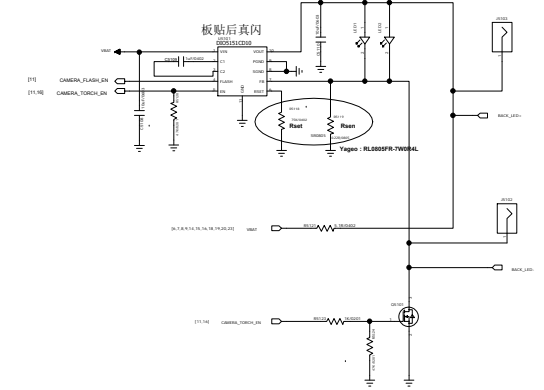

(VCAMD_1) LDO for Rear Camera (VCAMA_EXT1) LDO for Rear Camera

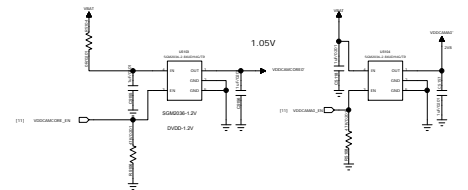

(VCAMAF) LDO for camera AF 2.8V

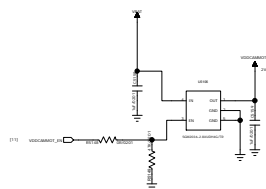

REVISION HISTORY			
VER.	REVISED BY	REVISION	DATE

TITLE & REV.			
DOCUMENT NO.			
DESIGNER	DATE	DEPARTMENT	
		Hardware DEPT	
CHK	DATE	COMPANY	
		Spreadtrum communications, Inc.	
APPROVED	DATE		
CONFIDENTIAL AND PROPRIETARY			

Accelerometer&GYRO: ICM-20600

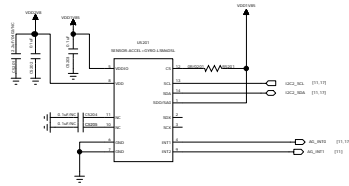

ALS & PROX

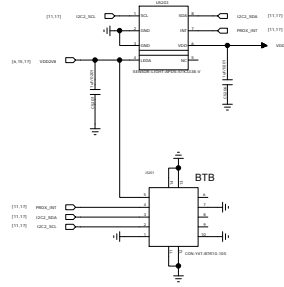

G Sensor

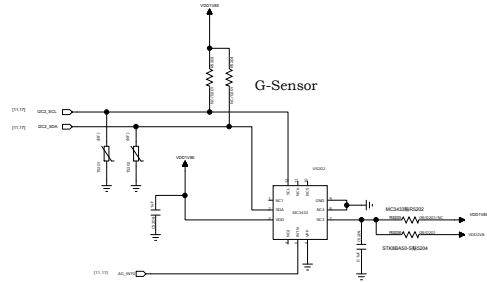

FingerPrint ID

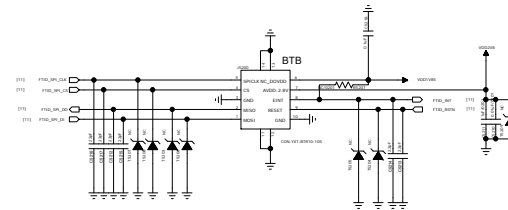

Magnetic Sensor

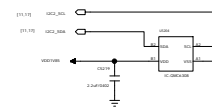

REVISION HISTORY		DATE	DESCRIPTION
1.0	1.0	2018-01-01	Initial Release

DESIGNER	DATE	APPROVED

TITLE & REV	
DESIGNER	
DATE	
APPROVED	

REVISION HISTORY			
REV.	DATE	DESCRIPTION	BY

BATTERY

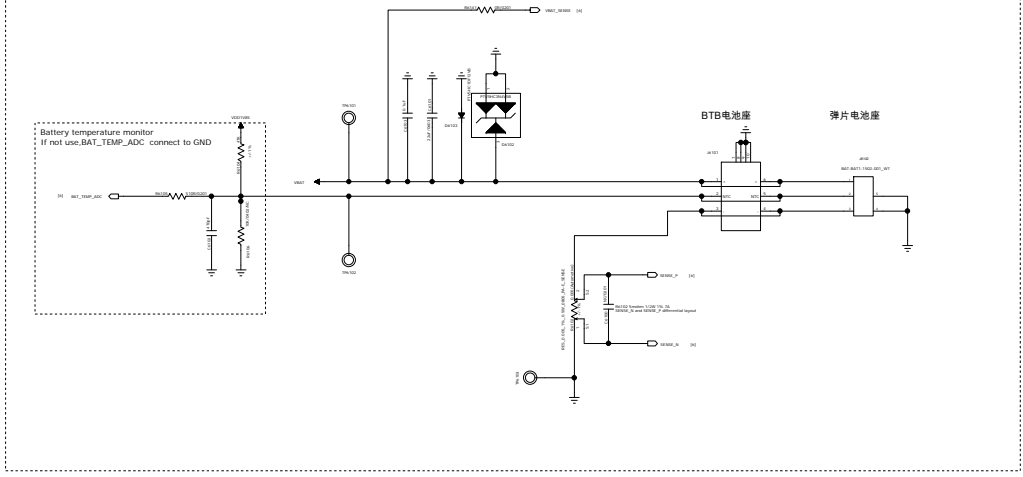

Main Charger

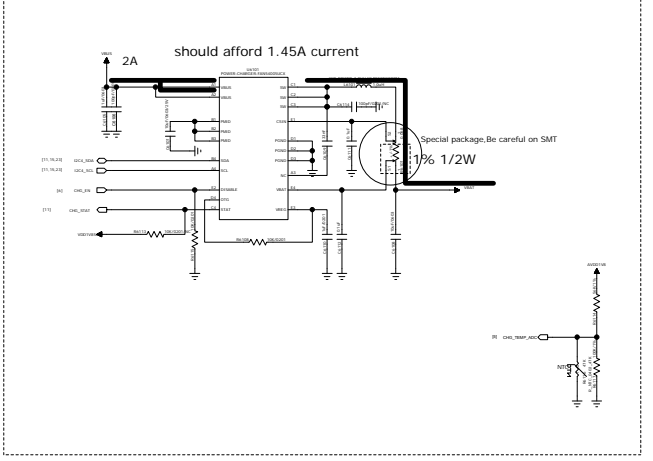

Switching charger II

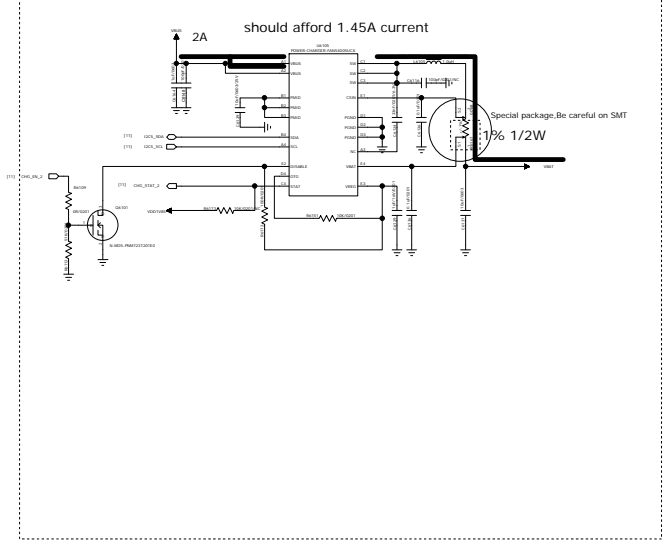

TITLE & REV.			
DESCRIPTION NO.			
DESIGNER	DATE	CONTRACT	
		Hardware DEPT	
		Company	
		Spreadtrum communications, Inc.	
APPROVED	DATE		
CONFIDENTIAL AND PROPRIETARY			

REVISION HISTORY			
REV.	DATE	DESCRIPTION	BY

Volume Key

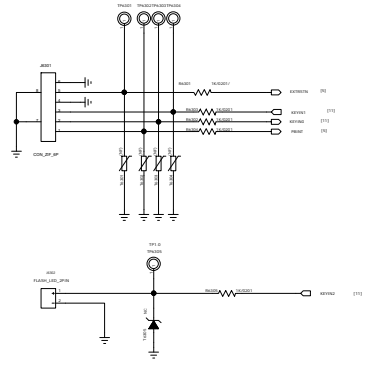

support two keys 7S reset. also support single key 7S reset with UMP510G
 Two keys :EXTRSTN+RSTN

KEYPAD LED(Reserved) RGB

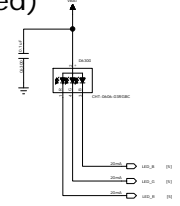

VIBRATOR

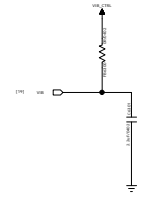

SHIELDING

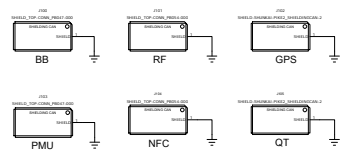

Grounding shrapnel

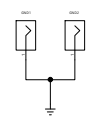

TITLE & REV.			
REVISION HISTORY			

DESIGNER	DATE	APPROVED	

TITLE & REV.	
REVISION HISTORY	

REVISION HISTORY			
REV.	REV. NO.	DESCRIPTION	DATE

SIMO & SIM1 & T_Flash

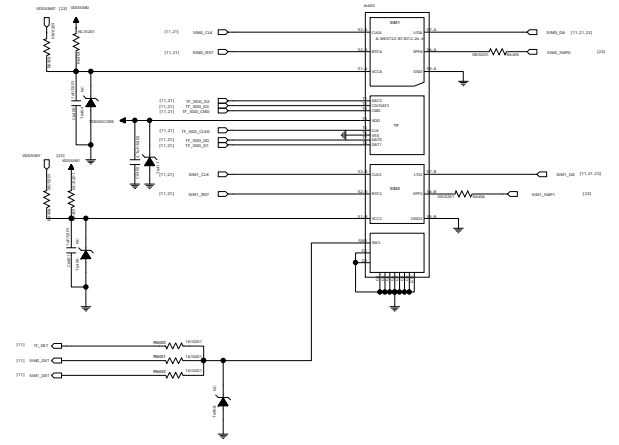

*R6403 *R6404 *R6406 *R6407 *R6405 *R6406							
With NFC	OR	NF	OR	NF	OR	NF	OR
No NFC	NF	OR	NF	OR	NF	OR	NF

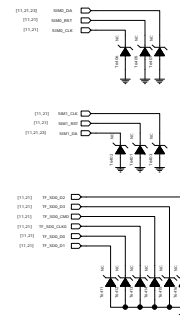

Reserve 0402 CAP for ESD defense and test point

Tray	Tray DET Value
Without Tray	L
Tray Inserted	H

TITLE & REV.		REVISION NO.	
DESIGNER	DATE	APPROVED	
CHK	DATE		
APPROVED	DATE	CONFIDENTIAL AND PROPRIETARY	

WIFI&BT ANT

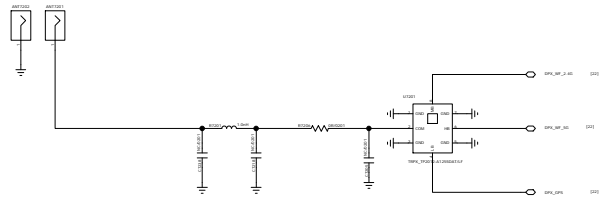

WIFI/BT SAW

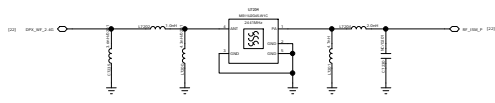

C7205 R7220
 Default: KCT8553C 10pF NF
 Option for R7217: 10pF 3.9k

5G WIFI



GNSS SAW LNA

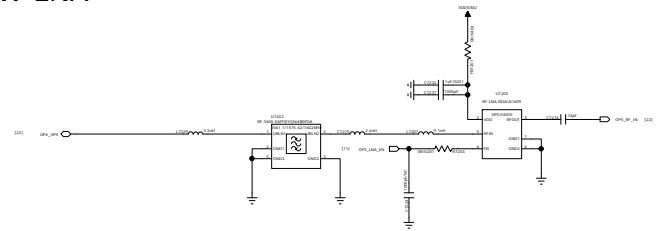

WCN

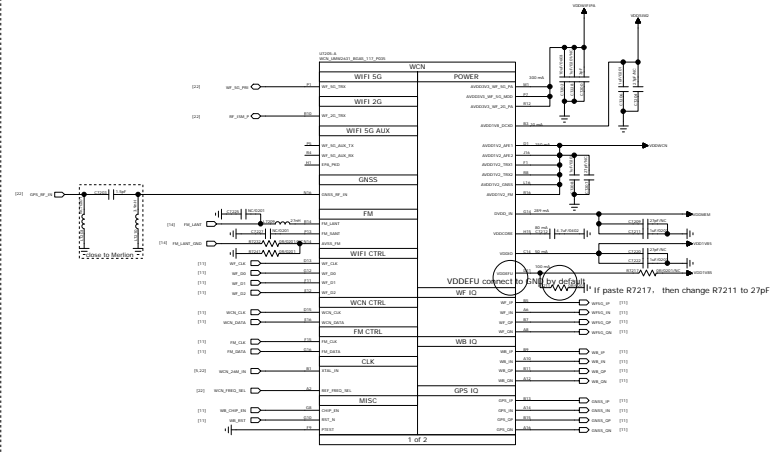

VDDEFU connect to GND by default. If paste R7217, then change R7211 to 27pF

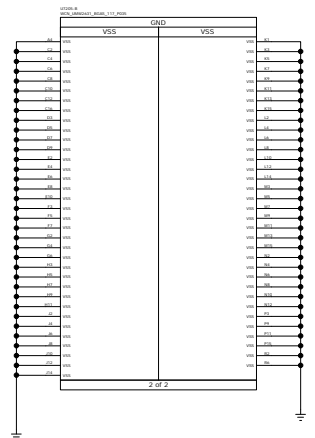

Bonding Option

FREQ_SEL---Internal Pull-up	
0	52MHz
1	26MHz



TSX (PMU) Only

	X7200	R7220	R7238	R7218	C7244	C7201	R7245	R0227
TSX (PMU) Only	NF	NF	NF	NF	NF	NF	NF	OR
TCXO(WCN) + DCXO(PMU)	TCXO	NF	OR	OR	22pF	1uF	OR	NF
TCXO(WCN) + 32K(PMU)	TCXO	OR	OR	NF	22pF	1uF	OR	NF



TITLE & REV		DATE	
DESIGNER	DATE	APPROVED	DATE
Hardware DEPT		Spreadtrum communications, Inc.	
CONFIDENTIAL AND PROPRIETARY			

REVISION HISTORY			
REV.	DESCRIPTION	DATE	BY

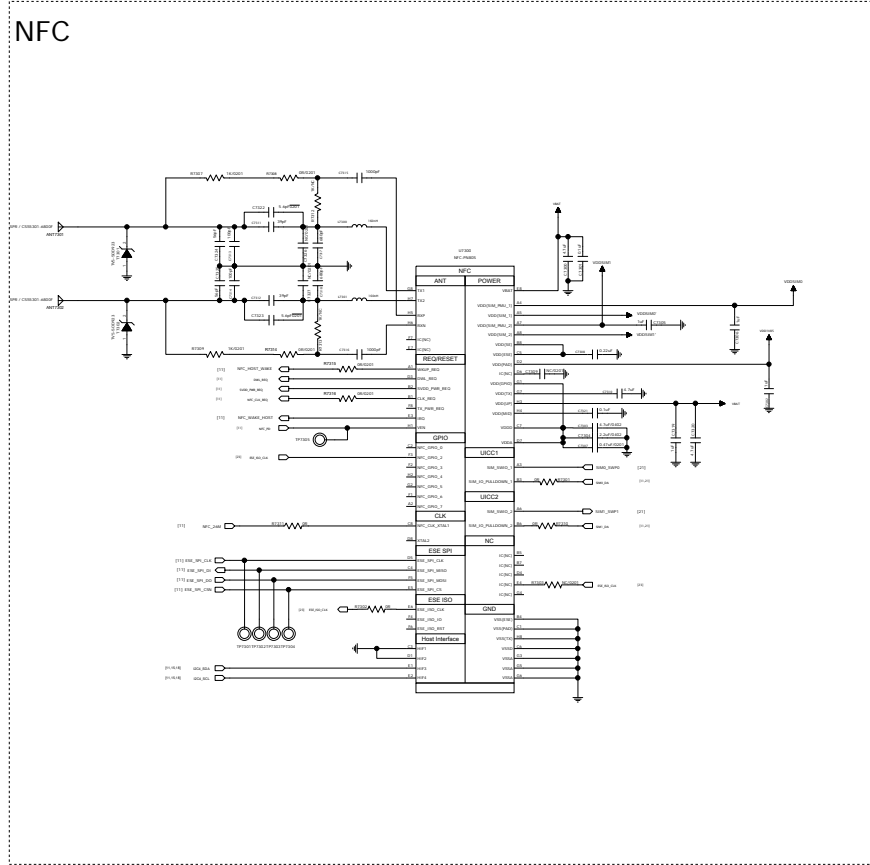

TITLE & REV.			
DESCRIPTION			
DESIGNED	DATE	APPROVED	DATE

