

FCC Test Report

APPLICANT : Yulong Computer Telecommunication
Scientific (Shenzhen) Co., Ltd.
EQUIPMENT : mobile phone
BRAND NAME : Coolpad
MODEL NAME : Coolpad 801ES
FCC ID : R38YL801ES
STANDARD : FCC 47 CFR FCC Part 15 Subpart B
CLASSIFICATION : Certification

The product was received on Sep. 17, 2013 and testing was completed on Oct. 29, 2013. We, SPORTON INTERNATIONAL (SHENZHEN) INC., would like to declare that the tested sample has been evaluated in accordance with the procedures given in ANSI C63.4-2003 and shown to be compliant with the applicable technical standards.

The test results in this report apply exclusively to the tested model / sample. Without written approval of SPORTON INTERNATIONAL (SHENZHEN) INC., the test report shall not be reproduced except in full.

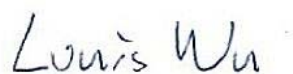

Reviewed by: Louis Wu / Manager

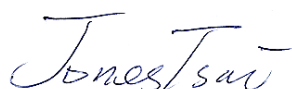

Approved by: Jones Tsai / Manager



SPORTON INTERNATIONAL (SHENZHEN) INC.

No. 3 Building, the third floor of south, Shahe River west, Fengzeyuan warehouse, Nanshan District, Shenzhen, Guangdong, P.R.C.



TABLE OF CONTENTS

REVISION HISTORY..... 3

SUMMARY OF TEST RESULT 4

1. GENERAL DESCRIPTION 5

 1.1. Applicant..... 5

 1.2. Manufacturer 5

 1.3. Feature of Equipment Under Test..... 5

 1.4. Product Specification of Equipment Under Test 6

 1.5. Modification of EUT 6

 1.6. Test Site 7

 1.7. Applied Standards 7

2. TEST CONFIGURATION OF EQUIPMENT UNDER TEST 8

 2.1. Test Mode 8

 2.2. Connection Diagram of Test System 10

 2.3. Support Unit used in test configuration and system..... 11

 2.4. EUT Operation Test Setup 12

3. TEST RESULT 13

 3.1. Test of AC Conducted Emission Measurement 13

 3.2. Test of Radiated Emission Measurement 17

4. LIST OF MEASURING EQUIPMENT 21

5. UNCERTAINTY OF EVALUATION 22

APPENDIX A. SETUP PHOTOGRAPHS



REVISION HISTORY

REPORT NO.	VERSION	DESCRIPTION	ISSUED DATE
FC311602-02	Rev. 01	Initial issue of report	Oct. 30, 2013



SUMMARY OF TEST RESULT

Report Section	FCC Rule	Description	Limit	Result	Remark
3.1	15.107	AC Conducted Emission	< 15.107 limits	PASS	Under limit 6.56 dB at 15.890 MHz
3.1	15.109	Radiated Emission	< 15.109 limits	PASS	Under limit 7.41 dB at 480.080 MHz

1. General Description

1.1. Applicant

Yulong Computer Telecommunication Scientific (Shenzhen) Co., Ltd.

Coolpad Information Harbor, 2nd Mengxi Road, Northern Part of Science&Technology Park, Nanshan district, Shenzhen, P.R.China

1.2. Manufacturer

Yulong Computer Telecommunication Scientific (Shenzhen) Co., Ltd.

Coolpad Information Harbor, 2nd Mengxi Road, Northern Part of Science&Technology Park, Nanshan district, Shenzhen, P.R.China

1.3. Feature of Equipment Under Test

Product Feature	
Equipment	mobile phone
Brand Name	Coolpad
Model Name	Coolpad 801ES
FCC ID	R38YL801ES
EUT supports Radios application	CDMA/EV-DO/LTE/WLAN 2.4GHz 802.11bgn HT 20/ Bluetooth v3.0 + EDR/Bluetooth v4.0
HW Version	P0
SW Version	4.1.001.P0.130904.801ES
EUT Stage	Identical Prototype

Remark: The above EUT's information was declared by manufacturer. Please refer to the specifications or user's manual for more detailed description.

1.4. Product Specification of Equipment Under Test

Product Specification subjective to this standard	
Tx Frequency	CDMA2000 BC0 : 824.70 MHz ~ 848.31 MHz CDMA2000 BC1 : 1851.25 MHz ~ 1908.75 MHz LTE Band 25 : 1850.7MHz ~ 1914.3 MHz 802.11b/g/n: 2412 MHz ~ 2462 MHz Bluetooth: 2402 MHz ~ 2480 MHz
Rx Frequency	CDMA2000 BC0 : 869.70 MHz ~ 893.31 MHz CDMA2000 BC1 : 1931.25 MHz ~ 1988.75 MHz LTE Band 25 : 1930.7MHz ~ 1994.3 MHz 802.11b/g/n: 2412 MHz ~ 2462 MHz Bluetooth: 2402 MHz ~ 2480 MHz GPS : 1.57542 GHz
Antenna Type	WWAN : PIFA Antenna LTE : PIFA Antenna WLAN : PIFA Antenna Bluetooth : PIFA Antenna GPS : PIFA Antenna
Type of Modulation	LTE: QPSK / 16QAM / 64QAM CDMA2000 : QPSK CDMA2000 1xEV-DO : QPSK/8PSK 802.11b : DSSS (DBPSK / DQPSK / CCK) 802.11g/n : OFDM (BPSK / QPSK / 16QAM / 64QAM) Bluetooth 4.0 - LE : GFSK Bluetooth 3.0 EDR : GFSK, $\pi/4$ -DQPSK, 8-DPSK GPS : BPSK

1.5. Modification of EUT

No modifications are made to the EUT during all test items.

1.6. Test Site

Test Site	SPORTON INTERNATIONAL (SHENZHEN) INC.		
Test Site Location	No. 3 Building, the third floor of south, Shahe River west, Fengzeyuan warehouse, Nanshan District, Shenzhen, Guangdong, P.R.C. TEL: +86-755- 3320-2398		
Test Site No.	Sporton Site No.		FCC Registration No.
	CO01-SZ	03CH01-SZ	831040

1.7. Applied Standards

According to the specifications of the manufacturer, the EUT must comply with the requirements of the following standards:

- ♦ FCC 47 CFR FCC Part 15 Subpart B
- ♦ ANSI C63.4-2003

Remark: All test items were verified and recorded according to the standards and without any deviation during the test.

2. Test Configuration of Equipment Under Test

2.1. Test Mode

The EUT has been associated with peripherals pursuant to ANSI C63.4-2003 and configuration operated in a manner tended to maximize its emission characteristics in a typical application.

Frequency range investigated: conduction (150 kHz to 30 MHz), radiation (30MHz to the 5th harmonic of the highest fundamental frequency or to 40 GHz, whichever is lower).

The following tables are showing the test modes as the worst cases and recorded in this report.

Item	EUT Configuration	Test Condition		
		EMI AC	EMI RE<1G	EMI RE≥1G
1.	Charging Mode (EUT with adapter)	☒	☒	Note 1
2.	Data application transferred mode (EUT with notebook)	☒	☒	☒

Abbreviations:

- EMI AC: AC conducted emissions
- EMI RE ≥ 1G: EUT radiated emissions ≥ 1GHz
- EMI RE < 1G: EUT radiated emissions < 1GHz

Note 1: Testing for this mode is not required or not the worst case.

Remark: For signal above 1GHz, the worst case was test item 2.

Test Items	EUT Configure Mode	Function Type
AC Conducted Emission	1/2	Mode 1: CDMA2000 BC0 Idle + Bluetooth Idle + WLAN Idle + USB Cable (Charging from Adapter) + Camera <Fig.1> Mode 2: LTE Band 25 Idle + Bluetooth Idle + WLAN Idle + USB Cable (Data Link with Notebook) + GPS Rx <Fig.2>
Radiated Emissions < 1GHz	1/2	Mode 1: CDMA2000 BC0 Idle + Bluetooth Idle + WLAN Idle + USB Cable (Charging from Adapter) + Camera <Fig.1> Mode 2: LTE Band 25 Idle + Bluetooth Idle + WLAN Idle + USB Cable (Data Link with Notebook) + GPS Rx <Fig.2>
Radiated Emissions ≥ 1GHz	2	Mode 1: LTE Band 25 Idle + Bluetooth Idle + WLAN Idle + USB Cable (Data Link with Notebook) + GPS Rx <Fig.2>
<p>Remark:</p> <ol style="list-style-type: none"> The worst case of AC Conducted Emission is mode 2; only the test data of this mode was reported. The worst case of Radiated Emissions < 1GHz is mode 2; only the test data of this mode is reported. Link with Notebook means data application transferred mode between EUT and Notebook. 		

2.2. Connection Diagram of Test System

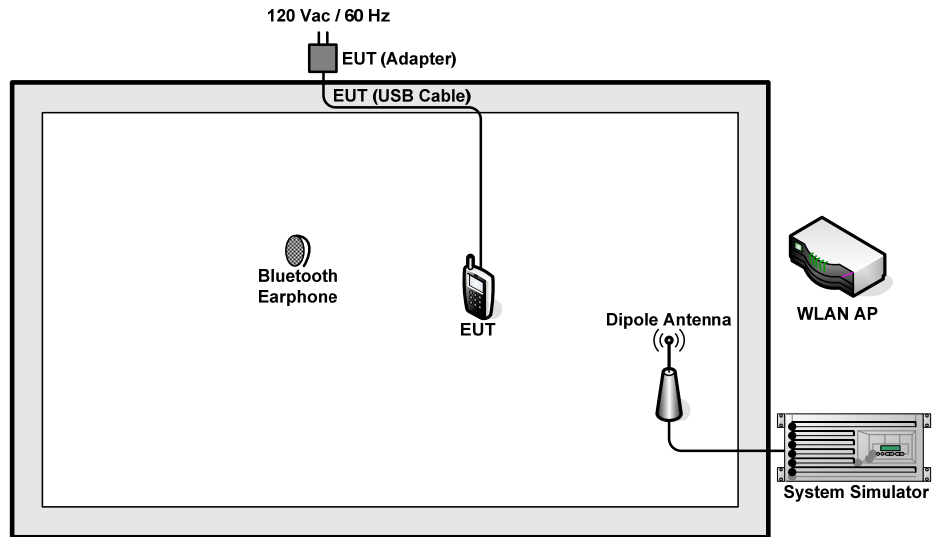

<Fig.1>

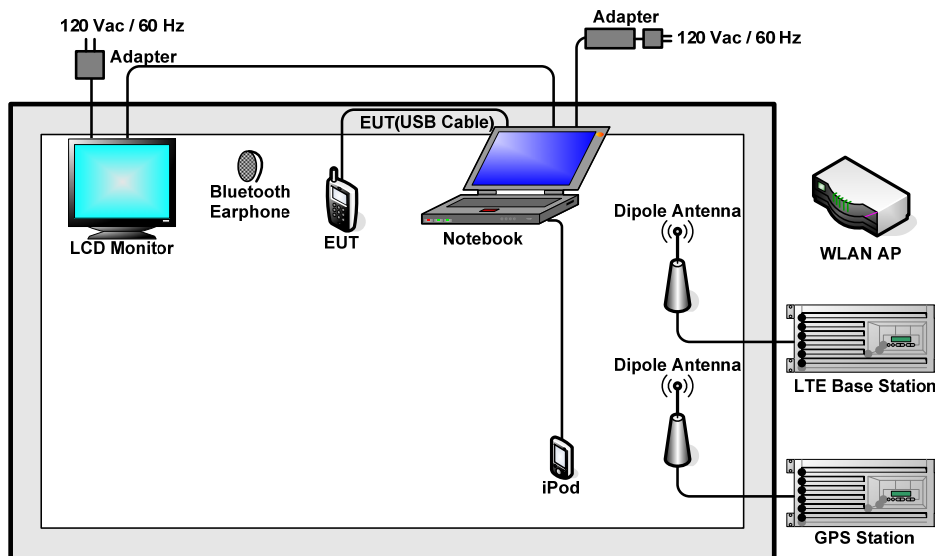

<Fig.2>

2.3. Support Unit used in test configuration and system

Item	Equipment	Trade Name	Model Name	FCC ID	Data Cable	Power Cord
1.	LTE Base Station	R&S	CMW500	FCC DoC	N/A	Unshielded, 1.8 m
2.	System Simulator	Agilent	E5515C	N/A	N/A	Unshielded, 1.8 m
3.	GPS Station	T&E	GS-50	N/A	N/A	Unshielded, 1.8 m
4.	WLAN AP	D-Link	DIR-615	N/A	N/A	Unshielded, 1.8 m
5.	Bluetooth Earphone	Nokia	BH-108	N/A	N/A	N/A
6.	Notebook	DELL	VOSTRO1440	FCC DoC	N/A	AC I/P: Unshielded, 1.8 m DC O/P: Shielded, 1.8 m
7.	LCD Monitor	DELL	1707FPt	FCC DoC	Shielded, 1.2 m	Unshielded, 1.8 m
8.	iPod	Apple	MC525 ZP/A	FCC DoC	Unshielded, 1.0 m	N/A



2.4. EUT Operation Test Setup

The EUT was in CDMA2000 and LTE idle mode during the testing. The EUT was synchronized to the BCCH, and was in continuous receiving mode by setting system simulator's paging reorganization.

At the same time, the EUT was attached to the Bluetooth earphone or WLAN AP, and the following programs installed in the EUT were programmed during the test.

1. Execute the program, "Winthrax" under WIN7 installed in notebook for files transfer with EUT via USB cable.
2. Turn on GPS function to make the EUT receive continuous signals from GPS station.
3. Turn on camera to capture images.

3. Test Result

3.1. Test of AC Conducted Emission Measurement

3.1.1 Limits of AC Conducted Emission

For equipment that is designed to be connected to the public utility (AC) power line, the radio frequency voltage that is conducted back onto the AC power line on any frequency or frequencies within the band 150 kHz to 30 MHz shall not exceed the limits in the following table.

Frequency of emission (MHz)	Conducted limit (dBuV)	
	Quasi-peak	Average
0.15-0.5	66 to 56*	56 to 46*
0.5-5	56	46
5-30	60	50

*Decreases with the logarithm of the frequency.

3.1.2 Measuring Instruments

The measuring equipment is listed in the section 4 of this test report.

3.1.3 Test Procedure

1. The EUT was placed 0.4 meter from the conducting wall of the shielding room was kept at least 80 centimeters from any other grounded conducting surface.
2. Connect EUT to the power mains through a line impedance stabilization network (LISN).
3. All the support units are connecting to the other LISN.
4. The LISN provides 50 ohm coupling impedance for the measuring instrument.
5. The FCC states that a 50 ohm, 50 microhenry LISN should be used.
6. Both sides of AC line were checked for maximum conducted interference.
7. The frequency range from 150 kHz to 30 MHz was searched.
8. Set the test-receiver system to Peak Detect Function and specified bandwidth with Maximum Hold Mode.

3.1.4 Test Setup

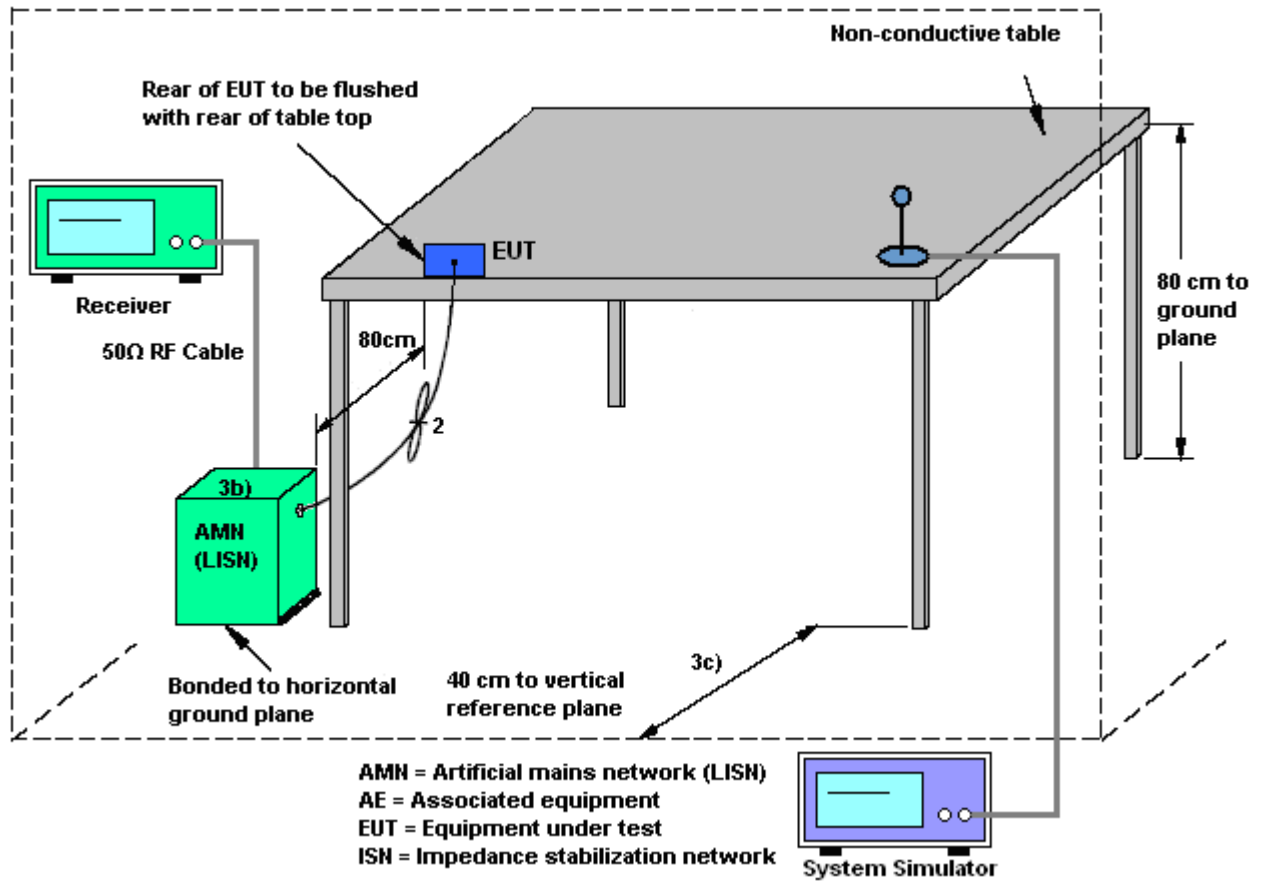



3.1.5 Test Result of AC Conducted Emission

Test Mode :	Mode 2	Temperature :	23~24°C
Test Engineer :	Henry Chen	Relative Humidity :	47~48%
Test Voltage :	120Vac / 60Hz	Phase :	Line
Function Type :	LTE Band 25 Idle + Bluetooth Idle + WLAN Idle + USB Cable (Data Link with Notebook) + GPS Rx		

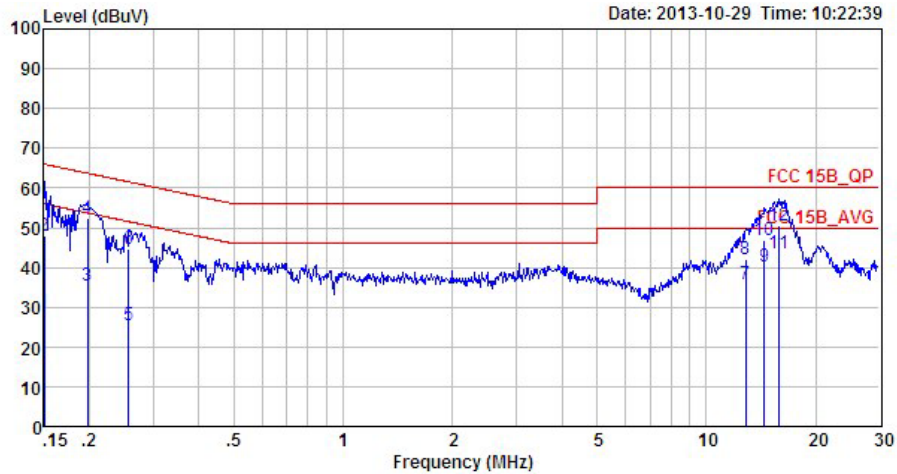

Site : CO01-SZ
 Condition: FCC 15B_QP LISN_L_20130328 LINE
 Project : (FC) 311602-02
 Mode : 2

	Freq	Level	Over Limit	Limit Line	Read Level	LISN Factor	Cable Loss	Remark
	MHz	dBuV	dB	dBuV	dBuV	dB	dB	
1	0.15	28.92	-27.08	56.00	18.50	0.06	10.36	Average
2	0.15	47.92	-18.08	66.00	37.50	0.06	10.36	QP
3	0.20	35.44	-18.27	53.71	25.10	0.07	10.27	Average
4	0.20	52.34	-11.37	63.71	42.00	0.07	10.27	QP
5	0.26	25.51	-26.05	51.56	15.20	0.09	10.22	Average
6	0.26	44.61	-16.95	61.56	34.30	0.09	10.22	QP
7	12.85	35.70	-14.30	50.00	24.49	0.83	10.38	Average
8	12.85	42.20	-17.80	60.00	30.99	0.83	10.38	QP
9	14.44	40.40	-9.60	50.00	29.09	0.89	10.42	Average
10	14.44	47.00	-13.00	60.00	35.69	0.89	10.42	QP
11 *	15.89	43.44	-6.56	50.00	32.00	0.99	10.45	Average
12	15.89	50.64	-9.36	60.00	39.20	0.99	10.45	QP



Test Mode :	Mode 2	Temperature :	23~24°C
Test Engineer :	Henry Chen	Relative Humidity :	47~48%
Test Voltage :	120Vac / 60Hz	Phase :	Neutral
Function Type :	LTE Band 25 Idle + Bluetooth Idle + WLAN Idle + USB Cable (Data Link with Notebook) + GPS Rx		

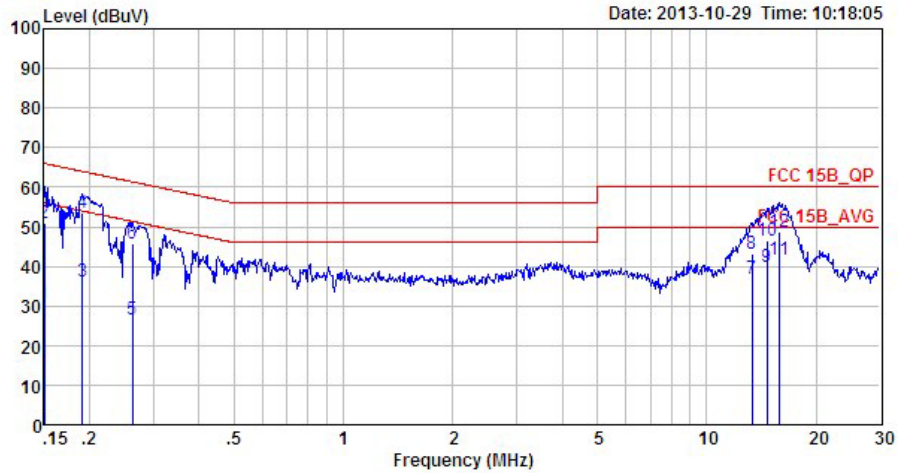

Site : CO01-SZ
 Condition: FCC 15B_QP LISN_N_20130328 NEUTRAL
 Project : (FC) 311602-02
 Mode : 2

	Freq	Level	Over Limit	Limit Line	Read Level	LISN Factor	Cable Loss	Remark
	MHz	dBuV	dB	dBuV	dBuV	dB	dB	
1	0.15	30.70	-25.30	56.00	20.30	0.04	10.36	Average
2	0.15	51.00	-15.00	66.00	40.60	0.04	10.36	QP
3	0.19	36.32	-17.66	53.98	26.00	0.04	10.28	Average
4	0.19	53.52	-10.46	63.98	43.20	0.04	10.28	QP
5	0.26	26.55	-24.79	51.34	16.30	0.04	10.21	Average
6	0.26	45.75	-15.59	61.34	35.50	0.04	10.21	QP
7	13.34	36.86	-13.14	50.00	26.00	0.47	10.39	Average
8	13.34	43.26	-16.74	60.00	32.40	0.47	10.39	QP
9	14.67	40.02	-9.98	50.00	29.10	0.50	10.42	Average
10	14.67	46.52	-13.48	60.00	35.60	0.50	10.42	QP
11 *	15.89	41.73	-8.27	50.00	30.70	0.58	10.45	Average
12	15.89	48.73	-11.27	60.00	37.70	0.58	10.45	QP

3.2. Test of Radiated Emission Measurement

3.2.1. Limit of Radiated Emission

The emissions from an unintentional radiator shall not exceed the field strength levels specified in the following table:

Frequency (MHz)	Field Strength (microvolts/meter)	Measurement Distance (meters)
30 – 88	100	3
88 – 216	150	3
216 - 960	200	3
Above 960	500	3

3.2.2. Measuring Instruments

See list of measuring instruments of this test report.

3.2.3. Test Procedures

1. The EUT was placed on a turntable with 0.8 meter above ground.
2. The EUT was set 3 meters from the interference receiving antenna, which was mounted on the top of a variable height antenna tower.
3. The table was rotated 360 degrees to determine the position of the highest radiation.
4. The antenna is a Bi-Log antenna and its height is adjusted between one to four meters above ground to find the maximum value of the field strength for both horizontal polarization and vertical polarization of the antenna.
5. For each suspected emission, the EUT was arranged to its worst case and then tune the antenna tower (from 1 m to 4 m) and turntable (from 0 degree to 360 degrees) to find the maximum reading.
6. Set the test-receiver system to Peak Detect Function and specified bandwidth with Maximum Hold Mode.
7. If the emission level of the EUT in peak mode was 3 dB lower than the limit specified, peak values of EUT will be reported. Otherwise, the emission will be repeated by using the quasi-peak method and reported.
8. Emission level (dB μ V/m) = 20 log Emission level (μ V/m)
9. Corrected Reading: Antenna Factor + Cable Loss + Read Level - Preamp Factor = Level

3.2.4. Test Setup of Radiated Emission

For radiated emissions from 30MHz to 1GHz

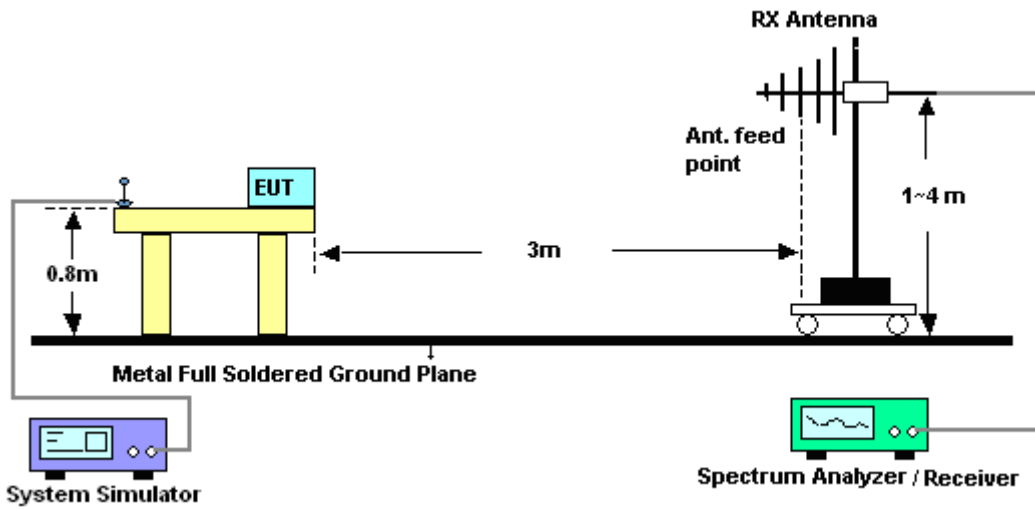

For radiated emissions above 1GHz

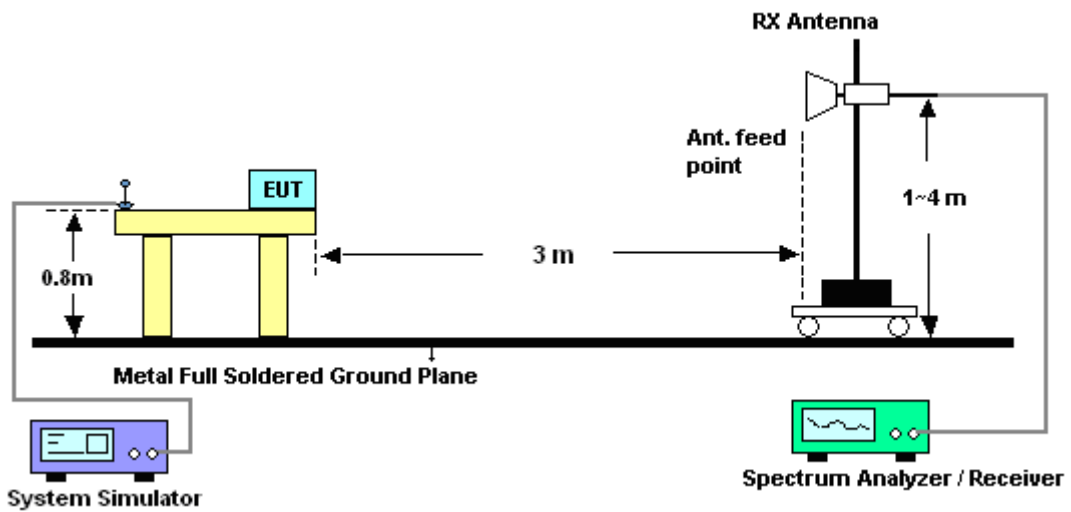



3.2.5. Test Result of Radiated Emission

Test Mode :	Mode 2	Temperature :	23~25°C
Test Engineer :	Robin Luo	Relative Humidity :	54~57%
Test Distance :	3m	Polarization :	Horizontal
Function Type :	LTE Band 25 Idle + Bluetooth Idle + WLAN Idle + USB Cable (Data Link with Notebook) + GPS Rx		

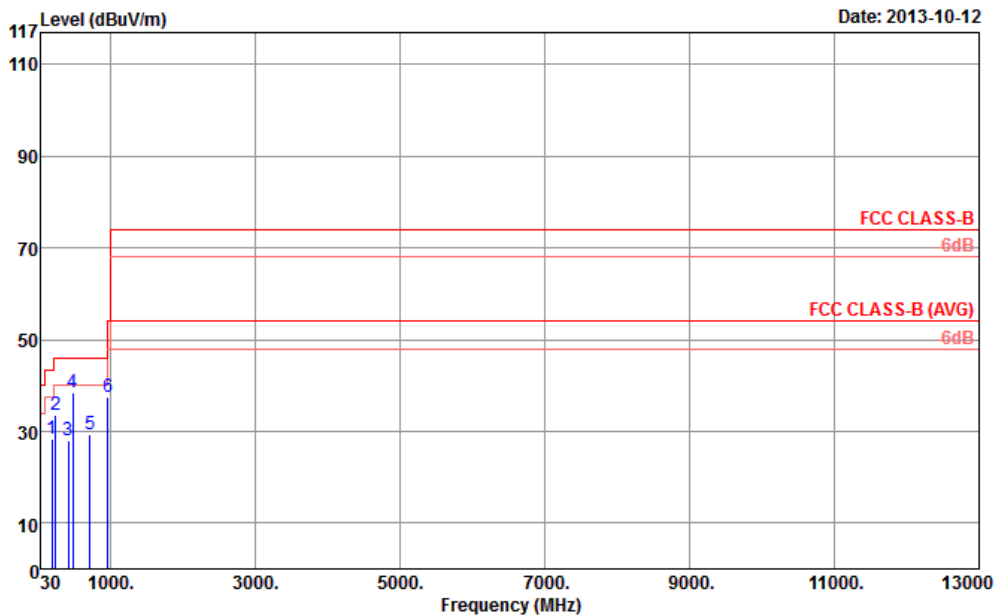

Site : 03CH01-SZ
 Condition : FCC CLASS-B 3m LF_ANT_121103 HORIZONTAL
 Project : (FC)311602-02
 Mode : Mode 2

	Freq	Level	Over Limit	Limit Line	ReadAntenna Level	Antenna Factor	Cable Loss	Preamp Factor	A/Pos	T/Pos	Remark
	MHz	dBuV/m	dB	dBuV/m	dBuV	dB/m	dB	dB	cm	deg	
1	188.11	28.30	-15.20	43.50	47.58	9.45	1.64	30.37	---	---	Peak
2	240.49	33.52	-12.48	46.00	50.00	11.90	1.82	30.20	---	---	Peak
3	416.06	28.14	-17.86	46.00	38.63	16.78	2.34	29.61	---	---	Peak
4 P	480.08	38.57	-7.43	46.00	48.29	17.20	2.48	29.40	100	320	Peak
5	719.67	29.28	-16.72	46.00	35.33	20.00	2.99	29.04	---	---	Peak
6	960.23	37.53	-16.47	54.00	41.02	21.80	3.43	28.72	---	---	Peak



Test Mode :	Mode 2	Temperature :	23~25°C
Test Engineer :	Robin Luo	Relative Humidity :	54~57%
Test Distance :	3m	Polarization :	Vertical
Function Type :	LTE Band 25 Idle + Bluetooth Idle + WLAN Idle + USB Cable (Data Link with Notebook) + GPS Rx		

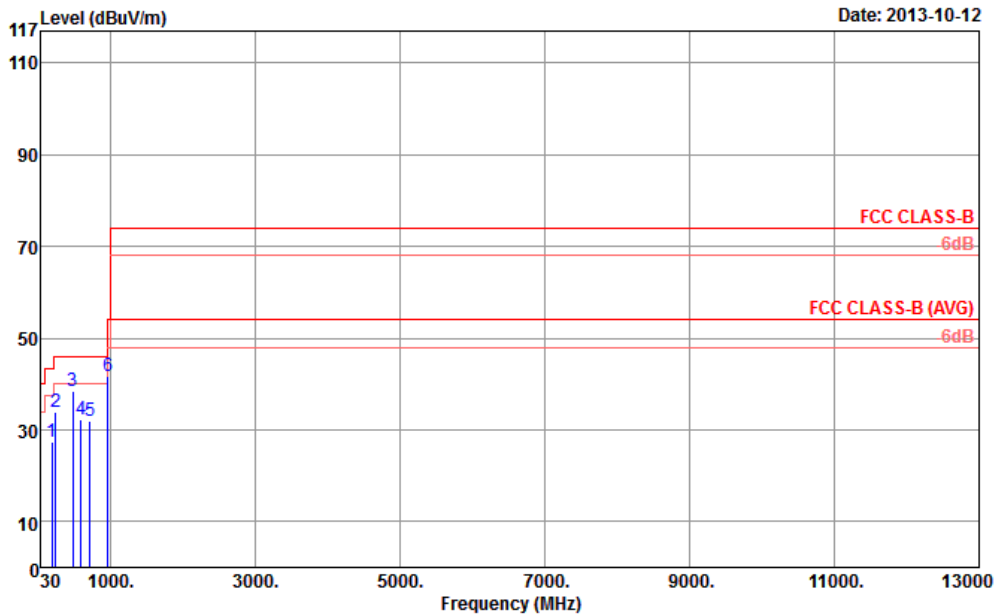

Site : 03CH01-SZ
 Condition : FCC CLASS-B 3m LF_ANT_121103 VERTICAL
 Project : (FC)311602-02
 Mode : Mode 2

	Freq	Level	Over Limit	Limit Line	ReadAntenna Level	Antenna Factor	Cable Loss	Preamp Factor	A/Pos	T/Pos	Remark
	MHz	dBuV/m	dB	dBuV/m	dBuV	dB/m	dB	dB	cm	deg	
1	188.11	27.42	-16.08	43.50	46.70	9.45	1.64	30.37	---	---	Peak
2	240.49	34.00	-12.00	46.00	50.48	11.90	1.82	30.20	---	---	Peak
3 P	480.08	38.59	-7.41	46.00	48.31	17.20	2.48	29.40	100	360	Peak
4	591.63	32.25	-13.75	46.00	39.98	18.74	2.74	29.21	---	---	Peak
5	719.67	31.88	-14.12	46.00	37.93	20.00	2.99	29.04	---	---	Peak
6	960.23	41.56	-12.44	54.00	45.05	21.80	3.43	28.72	---	---	Peak



4. List of Measuring Equipment

Instrument	Manufacturer	Model No.	Serial No.	Characteristics	Calibration Date	Test Date	Due Date	Remark
ESCIO TEST Receiver	R&S	1142.8007.0 3	100724	9kHz~3GHz	Mar. 28, 2013	Oct. 29, 2013	Mar. 27, 2014	Conduction (CO01-SZ)
AC LISN	ETS-LINDGREN	3816/2SH	00103912	9kHz~30MHz	Mar. 28, 2013	Oct. 29, 2013	Mar. 27, 2014	Conduction (CO01-SZ)
AC LISN (for auxiliary equipment)	ETS-LINDGREN	3816/2SH	00103892	9kHz~30MHz	Mar. 28, 2013	Oct. 29, 2013	Mar. 27, 2014	Conduction (CO01-SZ)
AC Power Source	Chroma	61602	616020000891	N/A	Nov. 20, 2012	Oct. 29, 2013	Nov. 19, 2013	Conduction (CO01-SZ)
Spectrum Analyzer	Agilent Technologies	N9038A	MY52260185	20Hz~26.5GHz	Apr. 04, 2013	Oct. 12, 2013	Apr. 03, 2014	Radiation (03CH01-SZ)
Double Ridge Horn Antenna	ETS Lindgren	3117	00119436	1GHz~18GHz	Oct. 11, 2013	Oct. 12, 2013	Oct. 10, 2014	Radiation (03CH01-SZ)
Bilog Antenna	SCHAFFNER	CBL6112B	2614	30MHz~2GHz	Nov. 03, 2012	Oct. 12, 2013	Nov. 02, 2013	Radiation (03CH01-SZ)
Amplifier	ADVANTEST	BB525C	E9007003	9kHz-3000MHz GAIN 30db	Mar. 28, 2013	Oct. 12, 2013	Mar. 27, 2014	Radiation (03CH01-SZ)
Amplifier	Yiai	AV3860B	04030	2GHz~26.5GHz	Mar. 28, 2013	Oct. 12, 2013	Mar. 27, 2014	Radiation (03CH01-SZ)
Turn Table	EM Electronics	EM 1000	N/A	0 ~ 360 degree	N/A	Oct. 12, 2013	N/A	Radiation (03CH01-SZ)
Antenna Mast	EM Electronics	EM 1000	N/A	1 m - 4 m	N/A	Oct. 12, 2013	N/A	Radiation (03CH01-SZ)

5. Uncertainty of Evaluation

Uncertainty of Radiated Emission Measurement (30 MHz ~ 1000 MHz)

Measuring Uncertainty for a Level of Confidence of 95% ($U = 2Uc(y)$)	2.54
---	------

Uncertainty of Radiated Emission Measurement (1 GHz ~ 40 GHz)

Measuring Uncertainty for a Level of Confidence of 95% ($U = 2Uc(y)$)	4.72
---	------