

FCC SAR Test Report

APPLICANT : Yulong Computer Telecommunication Scientific (Shenzhen) Co., Ltd.

EQUIPMENT : mobile phone

BRAND NAME : Coolpad

MODEL NAME : Coolpad 801ES

FCC ID : R38YL801ES

STANDARD : FCC 47 CFR Part 2 (2.1093)
ANSI/IEEE C95.1-1992
IEEE 1528-2003

The product was completely tested on Oct. 22, 2013. We, SPORTON INTERNATIONAL (SHENZHEN) INC., would like to declare that the tested sample has been evaluated in accordance with the procedures and shown the compliance with the applicable technical standards.

The test results in this report apply exclusively to the tested model / sample. Without written approval of SPORTON INTERNATIONAL (SHENZHEN) INC., the test report shall not be reproduced except in full.

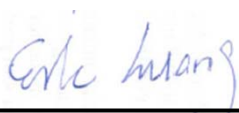

Reviewed by: Eric Huang / Deputy Manager



Approved by: Jones Tsai / Manager



SPORTON INTERNATIONAL (SHENZHEN) INC.

No. 101, Complex Building C, Guanlong Village, Xili Town, Nanshan District, Shenzhen, Guangdong, P.R.C.

SPORTON INTERNATIONAL (SHENZHEN) INC.

TEL : 86-755-8637-9589

FAX : 86-755-8637-9595

FCC ID : R38YL801ES

Page Number : 1 of 55

Report Issued Date : Oct. 30, 2013

Report Version : Rev. 01



Table of Contents

1. Statement of Compliance...4
2. Administration Data...5
2.1 Testing Laboratory...5
2.2 Applicant...5
2.3 Manufacturer...5
2.4 Application Details...5
3. General Information...6
3.1 Description of Equipment Under Test (EUT)...6
3.2 Maximum RF output power among production units...7
3.3 Applied Standard...10
3.4 Device Category and SAR Limits...10
3.5 Test Conditions...10
4. Specific Absorption Rate (SAR)...11
4.1 Introduction...11
4.2 SAR Definition...11
5. SAR Measurement System...12
5.1 E-Field Probe...13
5.2 Data Acquisition Electronics (DAE)...13
5.3 Robot...14
5.4 Measurement Server...14
5.5 Phantom...15
5.6 Device Holder...15
5.7 Data Storage and Evaluation...16
5.8 Test Equipment List...18
6. Tissue Simulating Liquids...19
7. System Verification Procedures...21
7.1 Purpose of System Performance check...21
7.2 System Setup...21
7.3 SAR System Verification Results...22
8. EUT Testing Position...23
8.1 Define two imaginary lines on the handset...23
8.2 Cheek Position...24
8.3 Tilted Position...24
8.4 Body Worn Position...25
9. Measurement Procedures...26
9.1 Spatial Peak SAR Evaluation...26
9.2 Power Reference Measurement...27
9.3 Area & Zoom Scan Procedures...27
9.4 Volume Scan Procedures...28
9.5 SAR Averaged Methods...28
9.6 Power Drift Monitoring...28
10. Bluetooth Exclusions Applied...28
11. Conducted RF Output Power (Unit: dBm)...29
12. Antenna Location...34
13. SAR Test Results...36
13.1 Head SAR...37
13.2 Hotspot SAR...38
13.3 Body Worn SAR...40
13.4 Repeated SAR Measurement...42
13.5 Highest SAR Plot...43
14. Simultaneous Transmission Analysis...47
14.1 Head Exposure Conditions...48
14.2 Hotspot Exposure Conditions...49
14.3 Body-Worn Exposure Conditions...50
14.4 SPLSR Evaluation and Analysis...51
15. Uncertainty Assessment...53
16. References...55
Appendix A. Plots of System Performance Check
Appendix B. Plots of SAR Measurement
Appendix C. DASY Calibration Certificate
Appendix D. Test Setup Photos



Revision History

REPORT NO.	VERSION	DESCRIPTION	ISSUED DATE
FA311602-02	Rev. 01	Initial issue of report	Oct. 30, 2013



1. Statement of Compliance

The maximum results of Specific Absorption Rate (SAR) found during testing for **Yulong Computer Telecommunication Scientific (Shenzhen) Co., Ltd. mobile phone, Coolpad** are as follows.

<Highest SAR Summary>

Exposure Position	Frequency Band	Reported 1g-SAR (W/kg)	Equipment Class	Highest Reported 1g-SAR (W/kg)
Head	CDMA2000 BC0	0.19	PCE	0.70
	CDMA2000 BC1	0.70		
	LTE Band 25	0.07		
	WLAN 2.4GHz Band	0.26	DTS	0.26
Hotspot (Separation 1cm)	CDMA2000 BC0	0.52	PCE	1.54
	CDMA2000 BC1	1.54		
	LTE Band 25	1.19		
	WLAN 2.4GHz Band	0.13	DTS	0.13
Body-worn (Separation 1cm)	CDMA2000 BC0	0.57	PCE	1.58
	CDMA2000 BC1	1.58		
	LTE Band 25	1.19		
	WLAN 2.4GHz Band	0.13	DTS	0.13

<Highest Simultaneous transmission SAR>

Exposure Position	Frequency Band	Equipment Class	Highest Reported Simultaneous Transmission 1g-SAR (W/kg)
Body-worn (Separation 1cm)	CDMA2000 BC1	PCE	1.59
	WLAN 2.4GHz Band	DTS	

Exposure Position	Frequency Band	Equipment Class	Highest Reported Simultaneous Transmission 1g-SAR (W/kg)
Hotspot (Separation 1cm)	CDMA2000 BC1	PCE	1.58
	2.4GHz Bluetooth	DSS	

This device is in compliance with Specific Absorption Rate (SAR) for general population/uncontrolled exposure limits (1.6 W/kg) specified in FCC 47 CFR part 2 (2.1093) and ANSI/IEEE C95.1-1992, and had been tested in accordance with the measurement methods and procedures specified in IEEE 1528-2003.



2. Administration Data

2.1 Testing Laboratory

Test Site	SPORTON INTERNATIONAL (SHENZHEN) INC.
Test Site Location	No. 101, Complex Building C, Guanlong Village, Xili Town, Nanshan District, Shenzhen, Guangdong, P.R.C. TEL: +86-755-8637-9589 FAX: +86-755-8637-9595

2.2 Applicant

Company Name	Yulong Computer Telecommunication Scientific (Shenzhen) Co., Ltd.
Address	Coolpad Information Harbor, 2nd Mengxi Road, Northern Part of Science&Technology Park, Nanshan district, Shenzhen, P.R.China

2.3 Manufacturer

Company Name	Yulong Computer Telecommunication Scientific (Shenzhen) Co., Ltd.
Address	Coolpad Information Harbor, 2nd Mengxi Road, Northern Part of Science&Technology Park, Nanshan district, Shenzhen, P.R.China

2.4 Application Details

Date of Start during the Test	Oct. 14, 2013
Date of End during the Test	Oct. 22, 2013



3. General Information

3.1 Description of Equipment Under Test (EUT)

Product Feature & Specification	
EUT	mobile phone
Brand Name	Coolpad
Model Name	Coolpad 801ES
FCC ID	R38YL801ES
MEID Code	99000313009152
Wireless Technology and Frequency Range	CDMA2000 BC0: 824.7 MHz ~ 848.31 MHz CDMA 2000 BC1: 1851.25 MHz ~ 1908.75 MHz LTE Band 25: 1850.7 MHz ~ 1914.3 MHz WLAN 2.4GHz Band: 2412 MHz ~ 2462 MHz Bluetooth: 2402 MHz ~ 2480 MHz
Mode	<ul style="list-style-type: none">• CDMA2000 : 1xRTT/1xEv-Do(Rel.0)/1xEv-Do(Rev.A)• LTE: QPSK, 16QAM• 802.11b/g/n HT20• Bluetooth v3.0+EDR, Bluetooth v4.0
Antenna Type	WWAN: PIFA Antenna WLAN: PIFA Antenna Bluetooth: PIFA Antenna
HW Version	P0
SW Version	4.1.001.P0.130904.801ES
EUT Stage	Identical Prototype
Remark:	<ol style="list-style-type: none">1. The above EUT's information was declared by manufacturer. Please refer to the specifications or user's manual for more detailed description.2. 802.11n-HT40 is not supported in 2.4GHz frequency band.3. This device supported VoIP in LTE (e.g. 3rd part VoIP).



3.2 Maximum RF output power among production units

Maximum Average Power for Production Unit (dBm)			
Mode	Band	CDMA2000 BC0	CDMA2000 BC1
1xRTT RC1 SO55		24	23.5
1xRTT RC3 SO55		24.5	23.5
1xRTT RC3 SO32 (+ F-SCH)		24	23.5
1xRTT RC3 SO32 (+SCH)		24	23.5
1xEV-DO Rev 0 (RTAP 153.6kbps)		24	23.5
1xEV-DO Rev A (RETAP 4096bits)		24	23.5

Maximum Target Average Power for Production Unit (dBm)			
Mode / Band	IEEE 802.11		
	b	g	n-HT20
WLAN 2.4GHz Band	15	14	14

Mode / Band	Maximum Target Average Power for Production Unit (dBm)			
	1Mbps (GFSK)	2Mbps ($\pi/4$ -DQPSK)	3Mbps (8-DPSK)	BT4.0-LE (GFSK)
2.4GHz Bluetooth	2	1	1	1



LTE Band 25				
average power(dBm)				
Modulation	BW (MHz)	RB size	Target MPR	Target Power
QPSK	20	≤ 18	0	24.5
QPSK	20	> 18	1	23.5
16QAM	20	≤ 18	1	23.5
16QAM	20	> 18	2	22.5
QPSK	15	≤ 16	0	24.5
QPSK	15	> 16	1	23.5
16QAM	15	≤ 16	1	23.5
16QAM	15	> 16	2	22.5
QPSK	10	≤ 12	0	24.5
QPSK	10	> 12	1	23.5
16QAM	10	≤ 12	1	23.5
16QAM	10	> 12	2	22.5
QPSK	5	≤ 8	0	24.5
QPSK	5	> 8	1	23.5
16QAM	5	≤ 8	1	23.5
16QAM	5	> 8	2	22.5
QPSK	3	≤ 4	0	24.5
QPSK	3	> 4	1	23.5
16QAM	3	≤ 4	1	23.5
16QAM	3	> 4	2	22.5
QPSK	1.4	≤ 5	0	24.5
QPSK	1.4	> 5	1	23.5
16QAM	1.4	≤ 5	1	23.5
16QAM	1.4	> 5	2	22.5

Remark:

1. By design, maximum LTE RF power of smaller supported bandwidth does not exceed the RF power of largest supported bandwidth; the information is included in “tune-up procedure” exhibit
2. LTE MPR implementation is the same for normal mode and power reduction mode.



The table below summarized necessary items addressed in KDB 941225 D05 v02.

FCC ID	R38YL801ES											
EUT	mobile phone											
Operating Frequency Range of each LTE transmission band	LTE Band 25: 1850.7 MHz ~ 1914.3 MHz											
Channel Bandwidth	1.4MHz, 3MHz, 5MHz, 10MHz, 15MHz, 20MHz											
Transmission (H, M, L) channel numbers and frequencies in each LTE band												
LTE Band 25												
	Bandwidth 1.4 MHz		Bandwidth 3 MHz		Bandwidth 5 MHz		Bandwidth 10 MHz		Bandwidth 15 MHz		Bandwidth 20 MHz	
	Ch. #	Freq. (MHz)	Ch. #	Freq. (MHz)	Ch. #	Freq. (MHz)	Ch. #	Freq. (MHz)	Ch. #	Freq. (MHz)	Ch. #	Freq. (MHz)
L	26047	1850.7	26055	1851.5	26065	1852.5	26090	1855	26115	1857.5	26140	1860
M	26365	1882.5	26365	1882.5	26365	1882.5	26365	1882.5	26365	1882.5	26365	1882.5
H	26683	1914.3	26675	1913.5	26665	1912.5	26640	1910	26615	1907.5	26590	1905

E category, uplink modulations used	Category 3, QPSK, and 16QAM																																						
LTE transmitter and antenna implementation (standalone or sharing hardware components / antennas)	A primary antenna is used for LTE transmitting and receiving, standalone. A 2 nd antenna is used for LTE receiving only, standalone.																																						
LTE Voice / Data requirements	Data only																																						
LTE MPR permanently built-in by design	Yes, per 3GPP TS 36.101 v11.0.0 Table 6.2.3-1: Maximum Power Reduction (MPR) for Power Class 3 <table border="1" style="margin-left: 40px;"> <thead> <tr> <th rowspan="2">Modulation</th> <th colspan="6">Channel bandwidth / Transmission bandwidth (RB)</th> <th rowspan="2">MPR (dB)</th> </tr> <tr> <th>1.4 MHz</th> <th>3.0 MHz</th> <th>5 MHz</th> <th>10 MHz</th> <th>15 MHz</th> <th>20 MHz</th> </tr> </thead> <tbody> <tr> <td>QPSK</td> <td>> 5</td> <td>> 4</td> <td>> 8</td> <td>> 12</td> <td>> 16</td> <td>> 18</td> <td>≤ 1</td> </tr> <tr> <td>16 QAM</td> <td>≤ 5</td> <td>≤ 4</td> <td>≤ 8</td> <td>≤ 12</td> <td>≤ 16</td> <td>≤ 18</td> <td>≤ 1</td> </tr> <tr> <td>16 QAM</td> <td>> 5</td> <td>> 4</td> <td>> 8</td> <td>> 12</td> <td>> 16</td> <td>> 18</td> <td>≤ 2</td> </tr> </tbody> </table>	Modulation	Channel bandwidth / Transmission bandwidth (RB)						MPR (dB)	1.4 MHz	3.0 MHz	5 MHz	10 MHz	15 MHz	20 MHz	QPSK	> 5	> 4	> 8	> 12	> 16	> 18	≤ 1	16 QAM	≤ 5	≤ 4	≤ 8	≤ 12	≤ 16	≤ 18	≤ 1	16 QAM	> 5	> 4	> 8	> 12	> 16	> 18	≤ 2
Modulation	Channel bandwidth / Transmission bandwidth (RB)						MPR (dB)																																
	1.4 MHz	3.0 MHz	5 MHz	10 MHz	15 MHz	20 MHz																																	
QPSK	> 5	> 4	> 8	> 12	> 16	> 18	≤ 1																																
16 QAM	≤ 5	≤ 4	≤ 8	≤ 12	≤ 16	≤ 18	≤ 1																																
16 QAM	> 5	> 4	> 8	> 12	> 16	> 18	≤ 2																																
LTE A-MPR	In the base station simulator configuration, Network Setting value is set to NS_01 to disable A-MPR during SAR testing.																																						
Base station simulator used for Testing	Anritsu MT8820C																																						
Power reduction applied to satisfy SAR compliance	No, The EUT doesn't support power reduction.																																						



3.3 Applied Standard

The Specific Absorption Rate (SAR) testing specification, method, and procedure for this device is in accordance with the following standards:

- FCC 47 CFR Part 2 (2.1093)
- ANSI/IEEE C95.1-1992
- IEEE 1528-2003
- FCC KDB 865664 D01 v01r01
- FCC KDB 865664 D02 v01r01
- FCC KDB 447498 D01 v05r01
- FCC KDB 648474 D04 v01r01
- FCC KDB 248227 D01 v01r02
- FCC KDB 941225 D01 v02
- FCC KDB 941225 D05 v02r02
- FCC KDB 941225 D06 v01r01

3.4 Device Category and SAR Limits

This device belongs to portable device category because its radiating structure is allowed to be used within 20 centimeters of the body of the user. Limit for General Population/Uncontrolled exposure should be applied for this device, it is 1.6 W/kg as averaged over any 1 gram of tissue.

3.5 Test Conditions

3.5.1 Ambient Condition

Ambient Temperature	20 to 24 °C
Humidity	< 60 %

3.5.2 Test Configuration

For WWAN SAR testing, the device was controlled by using a base station emulator. Communication between the device and the emulator was established by air link. The distance between the EUT and the antenna of the emulator is larger than 50 cm and the output power radiated from the emulator antenna is at least 30 dB smaller than the output power of EUT.

During WLAN SAR testing EUT is configured with the WLAN continuous TX tool, and the transmission duty factor was monitored on the spectrum analyzer with zero-span setting

Duty factor observed as below:

802.11b, 1Mbps: 97.60%

802.11b, 5.5Mbps: 88.33%

For WLAN SAR testing, WLAN engineering testing software installed on the EUT can provide continuous transmitting RF signal.

4. Specific Absorption Rate (SAR)

4.1 Introduction

SAR is related to the rate at which energy is absorbed per unit mass in an object exposed to a radio field. The SAR distribution in a biological body is complicated and is usually carried out by experimental techniques or numerical modeling. The standard recommends limits for two tiers of groups, occupational/controlled and general population/uncontrolled, based on a person's awareness and ability to exercise control over his or her exposure. In general, occupational/controlled exposure limits are higher than the limits for general population/uncontrolled.

4.2 SAR Definition

The SAR definition is the time derivative (rate) of the incremental energy (dW) absorbed by (dissipated in) an incremental mass (dm) contained in a volume element (dv) of a given density (ρ). The equation description is as below:

$$\text{SAR} = \frac{d}{dt} \left(\frac{dW}{dm} \right) = \frac{d}{dt} \left(\frac{dW}{\rho dv} \right)$$

SAR is expressed in units of Watts per kilogram (W/kg)

SAR measurement can be either related to the temperature elevation in tissue by

$$\text{SAR} = c \left(\frac{\delta T}{\delta t} \right)$$

Where: C is the specific heat capacity, δT is the temperature rise and δt is the exposure duration, or related to the electrical field in the tissue by

$$\text{SAR} = \frac{\sigma |E|^2}{\rho}$$

Where: σ is the conductivity of the tissue, ρ is the mass density of the tissue and E is the RMS electrical field strength.

However for evaluating SAR of low power transmitter, electrical field measurement is typically applied.

5. SAR Measurement System

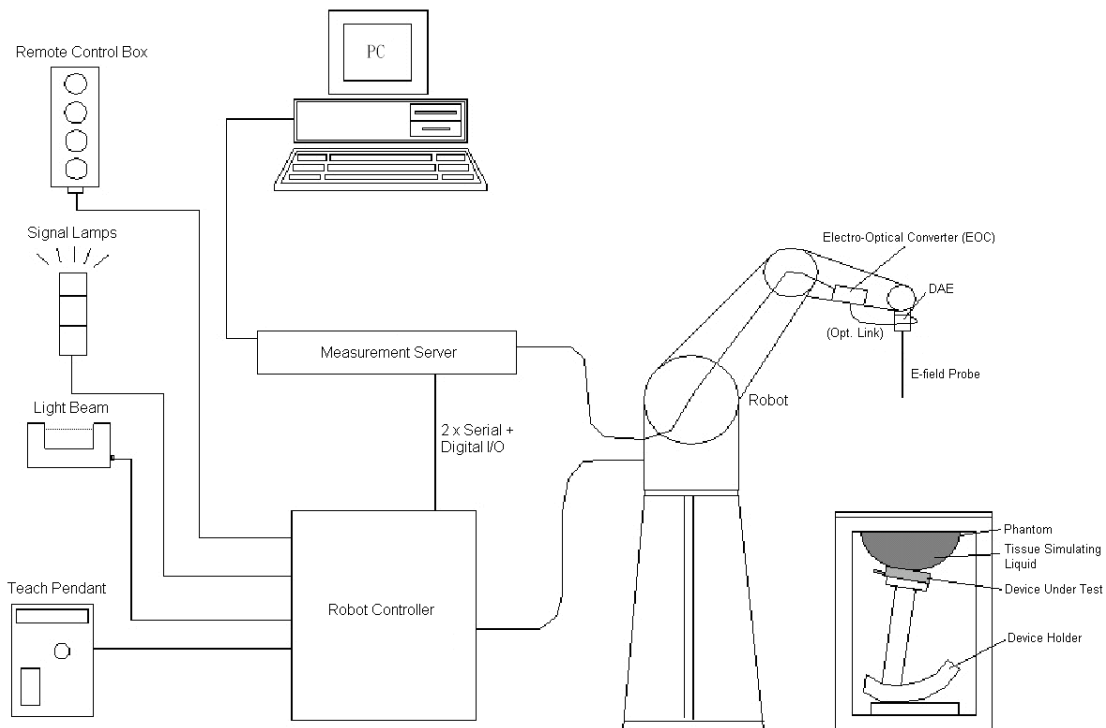

Fig 5.1 SPEAG DASY System Configurations

The DASY system for performance compliance tests is illustrated above graphically. This system consists of the following items:

- A standard high precision 6-axis robot with controller, a teach pendant and software
- A data acquisition electronic (DAE) attached to the robot arm extension
- A dosimetric probe equipped with an optical surface detector system
- The electro-optical converter (EOC) performs the conversion between optical and electrical signals
- A measurement server performs the time critical tasks such as signal filtering, control of the robot operation and fast movement interrupts.
- A probe alignment unit which improves the accuracy of the probe positioning
- A computer operating Windows XP
- DASY software
- Remote control with teach pendant and additional circuitry for robot safety such as warning lamps, etc.
- The SAM twin phantom
- A device holder
- Tissue simulating liquid
- Dipole for evaluating the proper functioning of the system

Component details are described in in the following sub-sections.

5.1 E-Field Probe

The SAR measurement is conducted with the dosimetric probe (manufactured by SPEAG).The probe is specially designed and calibrated for use in liquid with high permittivity. The dosimetric probe has special calibration in liquid at different frequency. This probe has a built in optical surface detection system to prevent from collision with phantom.

5.1.1 E-Field Probe Specification

<EX3DV4 Probe>

Construction	Symmetrical design with triangular core Built-in shielding against static charges PEEK enclosure material (resistant to organic solvents, e.g., DGBE)
Frequency	10 MHz to 6 GHz; Linearity: ± 0.2 dB
Directivity	± 0.3 dB in HSL (rotation around probe axis) ± 0.5 dB in tissue material (rotation normal to probe axis)
Dynamic Range	10 μ W/g to 100 mW/g; Linearity: ± 0.2 dB (noise: typically $< 1 \mu$ W/g)
Dimensions	Overall length: 330 mm (Tip: 20 mm) Tip diameter: 2.5 mm (Body: 12 mm) Typical distance from probe tip to dipole centers: 1 mm

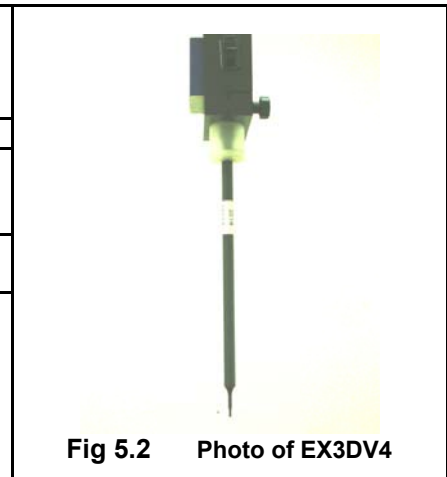

Fig 5.2 Photo of EX3DV4

5.1.2 E-Field Probe Calibration

Each probe needs to be calibrated according to a dosimetric assessment procedure with accuracy better than $\pm 10\%$. The spherical isotropy shall be evaluated and within ± 0.25 dB. The sensitivity parameters (NormX, NormY, and NormZ), the diode compression parameter (DCP) and the conversion factor (ConvF) of the probe are tested. The calibration data can be referred to appendix C of this report.

5.2 Data Acquisition Electronics (DAE)

The data acquisition electronics (DAE) consists of a highly sensitive electrometer-grade preamplifier with auto-zeroing, a channel and gain-switching multiplexer, a fast 16 bit AD-converter and a command decoder and control logic unit. Transmission to the measurement server is accomplished through an optical downlink for data and status information as well as an optical uplink for commands and the clock. The input impedance of the DAE is 200 MOhm; the inputs are symmetrical and floating. Common mode rejection is above 80 dB.



Fig 5.3 Photo of DAE

5.3 Robot

The SPEAG DASY system uses the high precision robots (DASY5: TX90XL) type from Stäubli SA (France). For the 6-axis controller system, the robot controller version (DASY5: CS8c) from Stäubli is used. The Stäubli robot series have many features that are important for our application:

- High precision (repeatability ± 0.035 mm)
- High reliability (industrial design)
- Jerk-free straight movements
- Low ELF interference (the closed metallic construction shields against motor control fields)



Fig 5.4 Photo of DASY5

5.4 Measurement Server

The measurement server is based on a PC/104 CPU board with CPU (DASY5: 400 MHz, Intel Celeron), chipdisk (DASY5: 128 MB), RAM (DASY5: 128 MB). The necessary circuits for communication with the DAE electronic box, as well as the 16 bit AD converter system for optical detection and digital I/O interface are contained on the DASY I/O board, which is directly connected to the PC/104 bus of the CPU board.

The measurement server performs all the real-time data evaluation for field measurements and surface detection, controls robot movements and handles safety operations.



Fig 5.5 Photo of Server for DASY5

5.5 Phantom

<SAM Twin Phantom>

Shell Thickness	2 ± 0.2 mm; Center ear point: 6 ± 0.2 mm
Filling Volume	Approx. 25 liters
Dimensions	Length: 1000 mm; Width: 500 mm; Height: adjustable feet
Measurement Areas	Left Hand, Right Hand, Flat Phantom

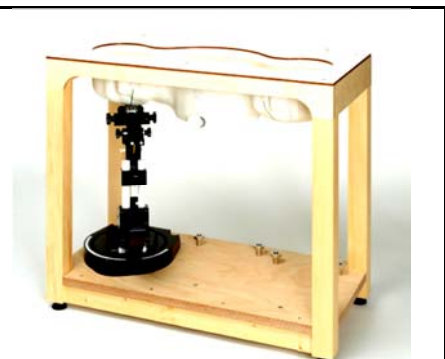

Fig 5.6 Photo of SAM Phantom

The bottom plate contains three pair of bolts for locking the device holder. The device holder positions are adjusted to the standard measurement positions in the three sections. A white cover is provided to tap the phantom during off-periods to prevent water evaporation and changes in the liquid parameters. On the phantom top, three reference markers are provided to identify the phantom position with respect to the robot.

5.6 Device Holder

<Device Holder for SAM Twin Phantom>

The SAR in the phantom is approximately inversely proportional to the square of the distance between the source and the liquid surface. For a source at 5 mm distance, a positioning uncertainty of ± 0.5 mm would produce a SAR uncertainty of ± 20 %. Accurate device positioning is therefore crucial for accurate and repeatable measurements. The positions in which the devices must be measured are defined by the standards.

The DASY device holder is designed to cope with different positions given in the standard. It has two scales for the device rotation (with respect to the body axis) and the device inclination (with respect to the line between the ear reference points). The rotation center for both scales is the ear reference point (ERP). Thus the device needs no repositioning when changing the angles.

The DASY device holder is constructed of low-loss POM material having the following dielectric parameters: relative permittivity $\epsilon = 3$ and loss tangent $\delta = 0.02$. The amount of dielectric material has been reduced in the closest vicinity of the device, since measurements have suggested that the influence of the clamp on the test results could thus be lowered.



Fig 5.7 Device Holder

5.7 Data Storage and Evaluation

5.7.1 Data Storage

The DASY software stores the assessed data from the data acquisition electronics as raw data (in microvolt readings from the probe sensors), together with all the necessary software parameters for the data evaluation (probe calibration data, liquid parameters and device frequency and modulation data) in measurement files. The post-processing software evaluates the desired unit and format for output each time the data is visualized or exported. This allows verification of the complete software setup even after the measurement and allows correction of erroneous parameter settings. For example, if a measurement has been performed with an incorrect crest factor parameter in the device setup, the parameter can be corrected afterwards and the data can be reevaluated.

The measured data can be visualized or exported in different units or formats, depending on the selected probe type (e.g., [V/m], [A/m], [mW/g]). Some of these units are not available in certain situations or give meaningless results, e.g., a SAR-output in a non-lose media, will always be zero. Raw data can also be exported to perform the evaluation with other software packages.

5.7.2 Data Evaluation

The DASY post-processing software (SEMCAD) automatically executes the following procedures to calculate the field units from the microvolt readings at the probe connector. The parameters used in the evaluation are stored in the configuration modules of the software :

Probe parameters :	- Sensitivity	Norm _i , a ₁₀ , a ₁₁ , a ₁₂
	- Conversion factor	ConvF _i
	- Diode compression point	dcp _i
Device parameters :	- Frequency	f
	- Crest factor	cf
Media parameters :	- Conductivity	σ
	- Density	ρ

These parameters must be set correctly in the software. They can be found in the component documents or they can be imported into the software from the configuration files issued for the DASY components. In the direct measuring mode of the multi-meter option, the parameters of the actual system setup are used. In the scan visualization and export modes, the parameters stored in the corresponding document files are used.

The first step of the evaluation is a linearization of the filtered input signal to account for the compression characteristics of the detector diode. The compensation depends on the input signal, the diode type and the DC-transmission factor from the diode to the evaluation electronics. If the exciting field is pulsed, the crest factor of the signal must be known to correctly compensate for peak power.

The formula for each channel can be given as :

$$V_i = U_i + U_i^2 \cdot \frac{cf}{dcp_i}$$

with V_i = compensated signal of channel i , ($i = x, y, z$)
 U_i = input signal of channel i , ($i = x, y, z$)
 cf = crest factor of exciting field (DASY parameter)
 dcp_i = diode compression point (DASY parameter)

From the compensated input signals, the primary field data for each channel can be evaluated :

$$\text{E-field Probes : } E_i = \sqrt{\frac{V_i}{\text{Norm}_i \cdot \text{ConvF}}}$$

$$\text{H-field Probes : } H_i = \sqrt{V_i \cdot \frac{a_{i0} + a_{i1}f + a_{i2}f^2}{f}}$$

with V_i = compensated signal of channel i , ($i = x, y, z$)
 Norm_i = sensor sensitivity of channel i , ($i = x, y, z$), $\mu\text{V}/(\text{V/m})^2$ for E-field Probes
 ConvF = sensitivity enhancement in solution
 a_{ij} = sensor sensitivity factors for H-field probes
 f = carrier frequency [GHz]
 E_i = electric field strength of channel i in V/m
 H_i = magnetic field strength of channel i in A/m

The RSS value of the field components gives the total field strength (Hermitian magnitude) :

$$E_{\text{tot}} = \sqrt{E_x^2 + E_y^2 + E_z^2}$$

The primary field data are used to calculate the derived field units.

$$\text{SAR} = E_{\text{tot}}^2 \cdot \frac{\sigma}{\rho \cdot 1000}$$

with SAR = local specific absorption rate in mW/g
 E_{tot} = total field strength in V/m
 σ = conductivity in [mho/m] or [Siemens/m]
 ρ = equivalent tissue density in g/cm^3

Note that the density is set to 1, to account for actual head tissue density rather than the density of the tissue simulating liquid.



5.8 Test Equipment List

Manufacturer	Name of Equipment	Type/Model	Serial Number	Calibration	
				Last Cal.	Due Date
SPEAG	835MHz System Validation Kit	D835V2	4d151	Mar. 25, 2013	Mar. 24, 2014
SPEAG	1900MHz System Validation Kit	D1900V2	5d170	Mar. 27, 2013	Mar. 26, 2014
SPEAG	2450MHz System Validation Kit	D2450V2	840	Mar. 26, 2013	Mar. 25, 2014
SPEAG	Data Acquisition Electronics	DAE4	1303	Nov. 22, 2012	Nov. 21, 2013
SPEAG	Dosimetric E-Field Probe	EX3DV4	3819	Nov. 26, 2012	Nov. 25, 2013
SPEAG	Dielectric Assessment Kit	DAK-3.5	1032	NCR	NCR
SPEAG	SAM Twin Phantom	QD 000 P40 CD	TP-1670	NCR	NCR
SPEAG	SAM Twin Phantom	QD 000 P40 CD	TP-1671	NCR	NCR
SPEAG	Phone Positioner	N/A	N/A	NCR	NCR
Anritsu	Radio communication analyzer	MT8820C	6201091028	Jul. 11, 2013	Jul. 10, 2014
Agilent	Wireless Communication Test Set	E5515C	MY50267224	Dec. 29, 2012	Dec. 28, 2013
R&S	Network Analyzer	ZVB8	100106	Nov. 20, 2012	Nov. 19, 2013
Anritsu	Power Meter	ML2495A	1218010	Mar. 28, 2013	Mar. 27, 2014
Anritsu	Power Sensor	MA2411B	1207253	Mar. 28, 2013	Mar. 27, 2014
Agilent	Dual Directional Coupler	778D	50422	Note 2	
Woken	Attenuator 1	WK0602-XX	N/A	Note 2	
PE	Attenuator 2	PE7005-10	N/A	Note 2	
PE	Attenuator 3	PE7005- 3	N/A	Note 2	
AR	Power Amplifier	5S1G4M2	328767	Note 3	
R&S	Spectrum Analyzer	FSP7	101230	Jun. 13, 2013	Jun. 12, 2014

Table 5.1 Test Equipment List

Note:

1. The calibration certificate of DASY can be referred to appendix C of this report.
2. The Insertion Loss calibration of Dual Directional Coupler and Attenuator were characterized via the network analyzer and compensated during system check.
3. In system check we need to monitor the level on the power meter, and adjust the power amplifier level to have precise power level to the dipole; the measured SAR will be normalized to 1W input power according to the ratio of 1W to the input power to the dipole. For system check, the calibration of the power amplifier is deemed not critically required for correct measurement; the power meter is critical and we do have calibration for it
4. Attenuator 1 insertion loss is calibrated by the network Analyzer, which the calibration is valid, before system check.

6. Tissue Simulating Liquids

For the measurement of the field distribution inside the SAM phantom with DASY, the phantom must be filled with around 25 liters of homogeneous body tissue simulating liquid. For head SAR testing, the liquid height from the ear reference point (ERP) of the phantom to the liquid top surface is larger than 15 cm, which is shown in Fig. 6.1. For body SAR testing, the liquid height from the center of the flat phantom to the liquid top surface is larger than 15 cm, which is shown in Fig. 6.2.



Fig 6.1 Photo of Liquid Height for Head SAR



Fig 6.2 Photo of Liquid Height for Body SAR

The following table gives the recipes for tissue simulating liquid.

Frequency (MHz)	Water (%)	Sugar (%)	Cellulose (%)	Salt (%)	Preventol (%)	DGBE (%)	Conductivity (σ)	Permittivity (ϵ_r)
For Head								
835	40.3	57.9	0.2	1.4	0.2	0	0.90	41.5
1800, 1900, 2000	55.2	0	0	0.3	0	44.5	1.40	40.0
2450	55.0	0	0	0	0	45.0	1.80	39.2
For Body								
835	50.8	48.2	0	0.9	0.1	0	0.97	55.2
1800, 1900, 2000	70.2	0	0	0.4	0	29.4	1.52	53.3
2450	68.6	0	0	0	0	31.4	1.95	52.7

Table 6.1 Recipes of Tissue Simulating Liquid



The dielectric parameters of the liquids were verified prior to the SAR evaluation using an SPEAG DAK-3.5 Dielectric Probe Kit and an Agilent Network Analyzer.

The following table shows the measuring results for simulating liquid.

Frequency (MHz)	Tissue Type	Liquid Temp. (°C)	Conductivity (σ)	Permittivity (ϵ_r)	Conductivity Target (σ)	Permittivity Target (ϵ_r)	Delta (σ) (%)	Delta (ϵ_r) (%)	Limit (%)	Date
835	Head	22.7	0.91	42.91	0.9	41.5	1.11	3.40	±5	Oct. 14, 2013
1900	Head	22.7	1.453	39.146	1.4	40	3.79	-2.14	±5	Oct. 14, 2013
1900	Head	22.8	1.417	40.994	1.4	40	1.21	2.49	±5	Oct. 22, 2013
2450	Head	22.6	1.878	40.464	1.8	39.2	4.33	3.22	±5	Oct. 22, 2013
835	Body	22.6	1.011	56.243	0.97	55.2	4.23	1.89	±5	Oct. 14, 2013
1900	Body	22.7	1.533	54.611	1.52	53.3	0.86	2.46	±5	Oct. 15, 2013
1900	Body	22.7	1.531	54.732	1.52	53.3	0.72	2.69	±5	Oct. 21, 2013
2450	Body	22.7	1.949	51.667	1.95	52.7	-0.05	-1.96	±5	Oct. 22, 2013

Table 6.2 Measuring Results for Simulating Liquid

7. System Verification Procedures

Each DASY system is equipped with one or more system validation kits. These units, together with the predefined measurement procedures within the DASY software, enable the user to conduct the system performance check and system validation. System validation kit includes a dipole, tripod holder to fix it underneath the flat phantom and a corresponding distance holder.

7.1 Purpose of System Performance check

The system performance check verifies that the system operates within its specifications. System and operator errors can be detected and corrected. It is recommended that the system performance check be performed prior to any usage of the system in order to guarantee reproducible results. The system performance check uses normal SAR measurements in a simplified setup with a well characterized source. This setup was selected to give a high sensitivity to all parameters that might fail or vary over time. The system check does not intend to replace the calibration of the components, but indicates situations where the system uncertainty is exceeded due to drift or failure.

7.2 System Setup

In the simplified setup for system evaluation, the EUT is replaced by a calibrated dipole and the power source is replaced by a continuous wave that comes from a signal generator. The calibrated dipole must be placed beneath the flat phantom section of the SAM twin phantom with the correct distance holder. The distance holder should touch the phantom surface with a light pressure at the reference marking and be oriented parallel to the long side of the phantom. The equipment setup is shown below:

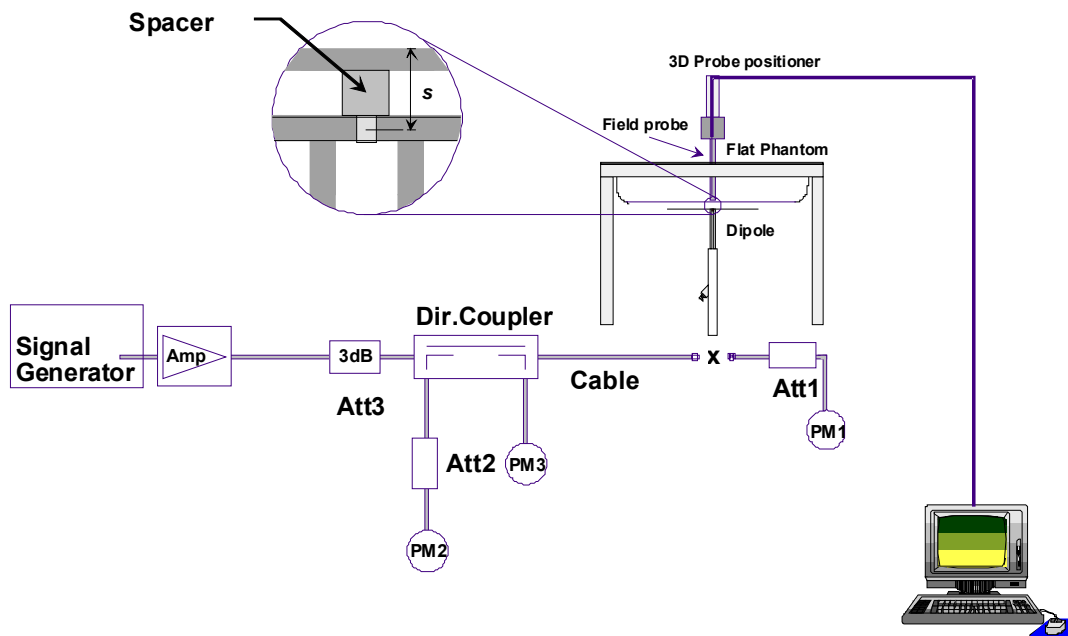

Fig 7.1 System Setup for System Evaluation

1. Signal Generator
2. Amplifier
3. Directional Coupler
4. Power Meter
5. Calibrated Dipole



Fig 7.2 Photo of Dipole Setup

7.3 SAR System Verification Results

Comparing to the original SAR value provided by SPEAG, the verification data should be within its specification of 10 %. Table 7.1 shows the target SAR and measured SAR after normalized to 1W input power. The table below indicates the system performance check can meet the variation criterion and the plots can be referred to Appendix A of this report.

Date	Frequency (MHz)	Tissue Type	Input Power (mW)	Dipole S/N	Probe S/N	DAE S/N	Measured SAR _{1g} (W/kg)	Targeted SAR _{1g} (W/kg)	Normalized SAR _{1g} (W/kg)	Deviation (%)
Oct. 14, 2013	835	Head	250	4d151	3819	1303	2.53	9.49	10.12	6.64
Oct. 14, 2013	1900	Head	250	5d170	3819	1303	10.2	40.2	40.8	1.49
Oct. 22, 2013	1900	Head	250	5d170	3819	1303	9.66	40.2	38.64	-3.88
Oct. 22, 2013	2450	Head	250	840	3819	1303	13	53.6	52	-2.99
Oct. 14, 2013	835	Body	250	4d151	3819	1303	2.31	9.43	9.24	-2.01
Oct. 15, 2013	1900	Body	250	5d170	3819	1303	10.2	41.2	40.8	-0.97
Oct. 21, 2013	1900	Body	250	5d170	3819	1303	10.3	41.2	41.2	0.00
Oct. 22, 2013	2450	Body	250	840	3819	1303	13.6	50.4	54.4	7.94

Table 7.1 Target and Measurement SAR after Normalized

8. EUT Testing Position

8.1 Define two imaginary lines on the handset

- The vertical centerline passes through two points on the front side of the handset - the midpoint of the width w_t of the handset at the level of the acoustic output, and the midpoint of the width w_b of the bottom of the handset.
- The horizontal line is perpendicular to the vertical centerline and passes through the center of the acoustic output. The horizontal line is also tangential to the face of the handset at point A.
- The two lines intersect at point A. Note that for many handsets, point A coincides with the center of the acoustic output; however, the acoustic output may be located elsewhere on the horizontal line. Also note that the vertical centerline is not necessarily parallel to the front face of the handset, especially for clamshell handsets, handsets with flip covers, and other irregularly shaped handsets.

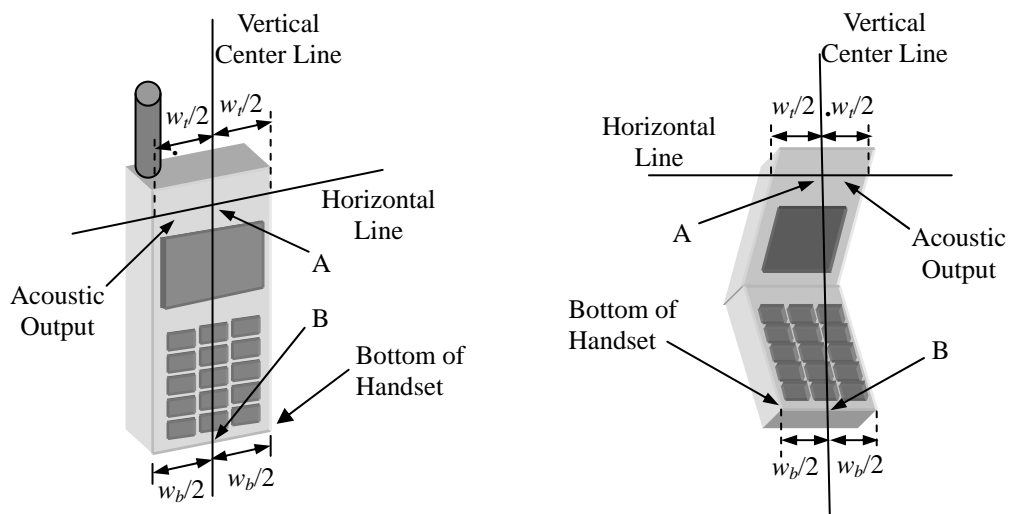

Fig 8.1 Illustration for Handset Vertical and Horizontal Reference Lines

8.2 Cheek Position

- (a) To position the device with the vertical center line of the body of the device and the horizontal line crossing the center piece in a plane parallel to the sagittal plane of the phantom. While maintaining the device in this plane, align the vertical center line with the reference plane containing the three ear and mouth reference point (M: Mouth, RE: Right Ear, and LE: Left Ear) and align the center of the ear piece with the line RE-LE.
- (b) To move the device towards the phantom with the ear piece aligned with the line LE-RE until the phone touched the ear. While maintaining the device in the reference plane and maintaining the phone contact with the ear, move the bottom of the phone until any point on the front side is in contact with the cheek of the phantom or until contact with the ear is lost (see Fig. 8.2).

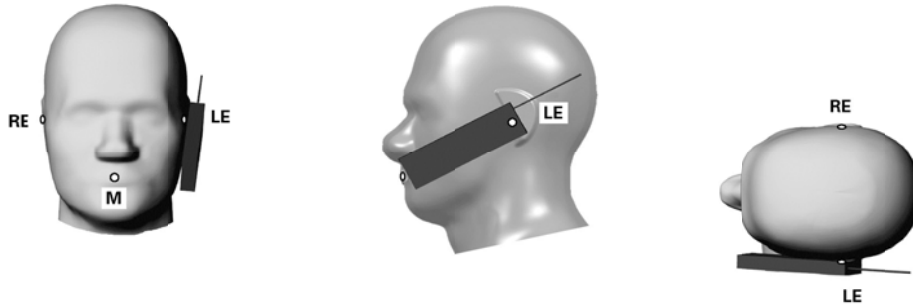

Fig 8.2 Illustration for Cheek Position

8.3 Tilted Position

- (a) To position the device in the “cheek” position described above.
- (b) While maintaining the device the reference plane described above and pivoting against the ear, moves it outward away from the mouth by an angle of 15 degrees or until contact with the ear is lost (sees Fig. 8.3).

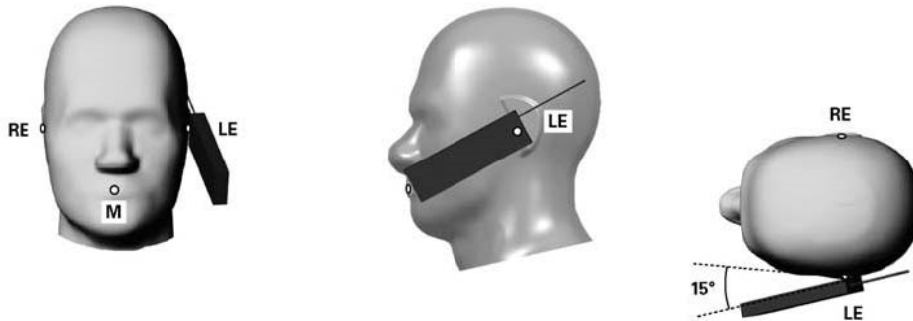

Fig 8.3 Illustration for Tilted Position

8.4 Body Worn Position

- (a) To position the device parallel to the phantom surface with either keypad up or down.
- (b) To adjust the device parallel to the flat phantom.
- (c) To adjust the distance between the device surface and the flat phantom to 1 cm.

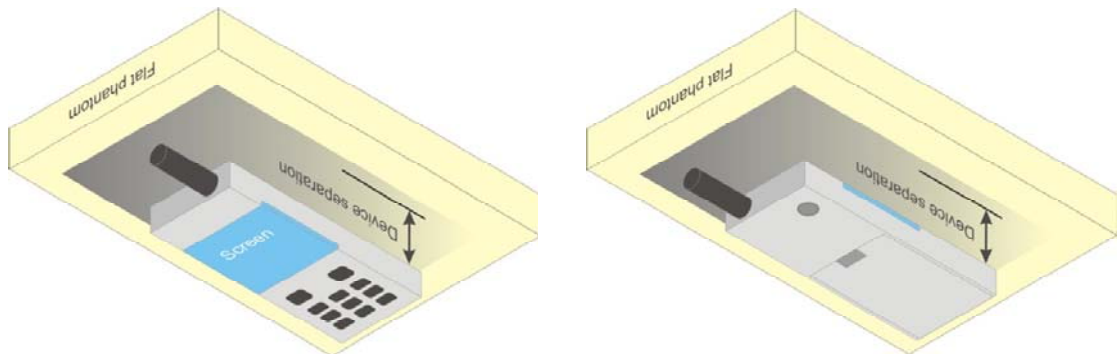

Fig 8.4 Illustration for Body Worn Position

8.5 Hotspot Position

- (a) To position the device parallel to the phantom surface with all sides and either keypad up or down.
- (b) To adjust the device parallel to the flat phantom.
- (c) To adjust the distance between the device and the flat phantom to 1 cm.

<EUT Setup Photos>

Please refer to Appendix D for the test setup photos.

9. Measurement Procedures

The measurement procedures are as follows:

<Conducted power measurement>

- (a) For WWAN power measurement, use base station simulator to configure EUT WWAN transmission in conducted connection with RF cable, at maximum power in each supported wireless interface and frequency band.
- (b) Read the WWAN RF power level from the base station simulator.
- (c) For WLAN/BT power measurement, use engineering software to configure EUT WLAN/BT continuously transmission, at maximum RF power in each supported wireless interface and frequency band
- (d) Connect EUT RF port through RF cable to the power meter, and measure WLAN/BT output power

<SAR measurement>

- (a) Use base station simulator to configure EUT WWAN transmission in radiated connection, and engineering software to configure EUT WLAN/BT continuously transmission, at maximum RF power, in the highest power channel.
- (b) Place the EUT in the positions as Appendix D demonstrates.
- (c) Set scan area, grid size and other setting on the DASY software.
- (d) Measure SAR results for the highest power channel on each testing position.
- (e) Find out the largest SAR result on these testing positions of each band
- (f) Measure SAR results for other channels in worst SAR testing position if the reported SAR of highest power channel is larger than 0.8 W/kg

According to the test standard, the recommended procedure for assessing the peak spatial-average SAR value consists of the following steps:

- (a) Power reference measurement
- (b) Area scan
- (c) Zoom scan
- (d) Power drift measurement

9.1 Spatial Peak SAR Evaluation

The procedure for spatial peak SAR evaluation has been implemented according to the test standard. It can be conducted for 1g and 10g, as well as for user-specific masses. The DASY software includes all numerical procedures necessary to evaluate the spatial peak SAR value.

The base for the evaluation is a "cube" measurement. The measured volume must include the 1g and 10g cubes with the highest averaged SAR values. For that purpose, the center of the measured volume is aligned to the interpolated peak SAR value of a previously performed area scan.

The entire evaluation of the spatial peak values is performed within the post-processing engine (SEMCAD). The system always gives the maximum values for the 1g and 10g cubes. The algorithm to find the cube with highest averaged SAR is divided into the following stages:

- (a) Extraction of the measured data (grid and values) from the Zoom Scan
- (b) Calculation of the SAR value at every measurement point based on all stored data (A/D values and measurement parameters)
- (c) Generation of a high-resolution mesh within the measured volume
- (d) Interpolation of all measured values from the measurement grid to the high-resolution grid
- (e) Extrapolation of the entire 3-D field distribution to the phantom surface over the distance from sensor to surface
- (f) Calculation of the averaged SAR within masses of 1g and 10g

9.2 Power Reference Measurement

The Power Reference Measurement and Power Drift Measurements are for monitoring the power drift of the device under test in the batch process. The minimum distance of probe sensors to surface determines the closest measurement point to phantom surface. This distance cannot be smaller than the distance of sensor calibration points to probe tip as defined in the probe properties.

9.3 Area & Zoom Scan Procedures

First Area Scan is used to locate the approximate location(s) of the local peak SAR value(s). The measurement grid within an Area Scan is defined by the grid extent, grid step size and grid offset. Next, in order to determine the EM field distribution in a three-dimensional spatial extension, Zoom Scan is required. The Zoom Scan is performed around the highest E-field value to determine the averaged SAR-distribution over 10 g. Area scan and zoom scan resolution setting follows KDB 865664 D01v01r01 quoted below.

When the 1-g SAR of the highest peak is within 2 dB of the SAR limit, additional zoom scans are required for other peaks within 2 dB of the highest peak that have not been included in any zoom scan to ensure there is no increase in SAR.

		≤ 3 GHz	> 3 GHz
Maximum distance from closest measurement point (geometric center of probe sensors) to phantom surface		5 ± 1 mm	$\frac{1}{2} \cdot \delta \cdot \ln(2) \pm 0.5$ mm
Maximum probe angle from probe axis to phantom surface normal at the measurement location		$30^\circ \pm 1^\circ$	$20^\circ \pm 1^\circ$
Maximum area scan spatial resolution: Δx_{Area} , Δy_{Area}		≤ 2 GHz: ≤ 15 mm 2 – 3 GHz: ≤ 12 mm	3 – 4 GHz: ≤ 12 mm 4 – 6 GHz: ≤ 10 mm
		When the x or y dimension of the test device, in the measurement plane orientation, is smaller than the above, the measurement resolution must be \leq the corresponding x or y dimension of the test device with at least one measurement point on the test device.	
Maximum zoom scan spatial resolution: Δx_{Zoom} , Δy_{Zoom}		≤ 2 GHz: ≤ 8 mm 2 – 3 GHz: ≤ 5 mm*	3 – 4 GHz: ≤ 5 mm* 4 – 6 GHz: ≤ 4 mm*
Maximum zoom scan spatial resolution, normal to phantom surface	uniform grid: $\Delta z_{Zoom}(n)$	≤ 5 mm	3 – 4 GHz: ≤ 4 mm 4 – 5 GHz: ≤ 3 mm 5 – 6 GHz: ≤ 2 mm
	graded grid	$\Delta z_{Zoom}(1)$: between 1 st two points closest to phantom surface	≤ 4 mm
		$\Delta z_{Zoom}(n>1)$: between subsequent points	$\leq 1.5 \cdot \Delta z_{Zoom}(n-1)$
Minimum zoom scan volume	x, y, z	≥ 30 mm	3 – 4 GHz: ≥ 28 mm 4 – 5 GHz: ≥ 25 mm 5 – 6 GHz: ≥ 22 mm
<p>Note: δ is the penetration depth of a plane-wave at normal incidence to the tissue medium; see draft standard IEEE P1528-2011 for details.</p> <p>* When zoom scan is required and the <i>reported</i> SAR from the area scan based 1-g SAR estimation procedures of KDB 447498 is ≤ 1.4 W/kg, ≤ 8 mm, ≤ 7 mm and ≤ 5 mm zoom scan resolution may be applied, respectively, for 2 GHz to 3 GHz, 3 GHz to 4 GHz and 4 GHz to 6 GHz.</p>			

9.4 Volume Scan Procedures

The volume scan is used for assess overlapping SAR distributions for antennas transmitting in different frequency bands. It is equivalent to an oversized zoom scan used in standalone measurements. The measurement volume will be used to enclose all the simultaneous transmitting antennas. For antennas transmitting simultaneously in different frequency bands, the volume scan is measured separately in each frequency band. In order to sum correctly to compute the 1g aggregate SAR, the EUT remain in the same test position for all measurements and all volume scan use the same spatial resolution and grid spacing. When all volume scan were completed, the software, SEMCAD postprocessor can combine and subsequently superpose these measurement data to calculating the multiband SAR.

9.5 SAR Averaged Methods

In DASYS, the interpolation and extrapolation are both based on the modified Quadratic Shepard's method. The interpolation scheme combines a least-square fitted function method and a weighted average method which are the two basic types of computational interpolation and approximation.

Extrapolation routines are used to obtain SAR values between the lowest measurement points and the inner phantom surface. The extrapolation distance is determined by the surface detection distance and the probe sensor offset. The uncertainty increases with the extrapolation distance. To keep the uncertainty within 1% for the 1 g and 10 g cubes, the extrapolation distance should not be larger than 5 mm.

9.6 Power Drift Monitoring

All SAR testing is under the EUT install full charged battery and transmit maximum output power. In DASYS measurement software, the power reference measurement and power drift measurement procedures are used for monitoring the power drift of EUT during SAR test. Both these procedures measure the field at a specified reference position before and after the SAR testing. The software will calculate the field difference in dB. If the power drifts more than 5%, the SAR will be retested.

10. Bluetooth Exclusions Applied

Mode Band	Average power(dBm)	
	Bluetooth v3.0+EDR	Bluetooth v4.0
2.4GHz Bluetooth	1.72	0.58

Note:

1. Per KDB 447498 D01v05r01, the 1-g and 10-g SAR test exclusion thresholds for 100 MHz to 6 GHz at *test separation distances* ≤ 50 mm are determined by:

$$[(\text{max. power of channel, including tune-up tolerance, mW}) / (\text{min. test separation distance, mm})] \cdot [\sqrt{f(\text{GHz})}] \leq 3.0 \text{ for}$$

1-g SAR and ≤ 7.5 for 10-g extremity SAR

- f(GHz) is the RF channel transmit frequency in GHz
- Power and distance are rounded to the nearest mW and mm before calculation
- The result is rounded to one decimal place for comparison

Bluetooth Max Power (dBm)	Test Distance (mm)	Frequency (GHz)	exclusion thresholds
2	5	2.48	0.50

2. Per KDB 447498 D01v05r01 exclusion thresholds is 0.50 < 3, RF exposure evaluation is not required.

11. Conducted RF Output Power (Unit: dBm)

<CDMA2000 Conducted Power>

Note:

1. Referring to KDB 941225 D01v02, the data device SAR is tested with Ev-Do Rev 0 (RTAP 153.6kbps). If 1xRTT and Ev-Do Rev A (RETAP 4096 bits) power is less than 1/4dB higher than Re v0, SAR tests with those settings are not necessary.
2. Considering VOIP capability, 1xEv-Do Rev. A SAR was repeated on the worst position of 1xRTT head SAR and body-worn SAR testing.
3. According to KDB 941225 D01v02, Head SAR for RC1+SO55 is not required because the maximum average output power of RC1 is less than 1/4 dB higher than RC3+SO55.
4. Referring to KDB 941225 D01v02, in Hotspot mode EUT is treated as data device and SAR is tested with Ev-Do Rev 0 (RTAP 153.6kbps). If 1xRTT and Ev-Do Rev A(RETAP 4096 bits) power is less than 1/4dB higher than Re v0, SAR tests with those settings are not necessary.

Band	CDMA2000 BC0			Tune-up Limit (dBm)	CDMA2000 BC1			Tune-up Limit (dBm)
	TX Channel	1013	384		777	25	600	
Frequency (MHz)	824.7	836.52	848.31		1851.25	1880	1908.75	
1xRTT RC1 SO55	23.76	23.39	23.47	24	23.17	23.09	23.10	23.5
1xRTT RC3 SO55	24.02	23.79	23.99	24.5	23.24	23.22	23.25	23.5
1xRTT RC3 SO32(+ F-SCH)	23.96	23.72	23.87	24	23.15	23.10	23.16	23.5
1xRTT RC3 SO32(+SCH)	23.74	23.35	23.43	24	23.10	23.07	23.11	23.5
1xEVDO RTAP 153.6Kbps	23.81	23.42	23.45	24	23.23	23.20	23.24	23.5
1xEVDO RETAP 4096Bits	23.80	23.39	23.42	24	23.14	23.08	23.15	23.5



<LTE Conducted Power>

Note:

1. Anritsu MT8820C base station simulator was used to setup the connection with EUT; the frequency band, channel bandwidth, RB allocation configuration, modulation type are set in the base station simulator to configure EUT transmitting at maximum power and at different configurations which are requested to be reported to FCC, for conducted power measurement and SAR testing.
2. Per KDB 941225 D05v02r02, when a properly configured base station simulator is used for the SAR and power measurements, spectrum plots for each RB allocation and offset configuration is not required.
3. Per KDB 941225 D05v02r02, start with the largest channel bandwidth and measure SAR for QPSK with 1 RB allocation, using the RB offset and required test channel combination with the highest maximum output power for RB offsets at the upper edge, middle and lower edge of each required test channel.
4. Per KDB 941225 D05v02r02, 50% RB allocation for QPSK SAR testing follows 1RB QPSK allocation procedure.
5. Per KDB 941225 D05v02r02, when reported SAR of 1RB and 50%RB allocation for QPSK $\leq 0.8W/kg$, and 100%RB with QPSK output power is less than 1RB and 50%RB, 100%RB allocation for QPSK is not required.
6. Per KDB 941225 D05v02r02, when reported SAR of 1RB or 50%RB allocation for QPSK $> 0.8W/kg$ for any exposure position, SAR testing of 100%RB allocation for QPSK is performed at the highest power channel.
7. 16QAM output power for each RB allocation configuration is $>$ not $\frac{1}{2}$ dB higher than the same configuration in QPSK and the reported SAR for the QPSK configuration is $\leq 1.45 W/kg$; Per KDB 941225 D05v02, 16QAM SAR testing is not required.
8. Smaller bandwidth output power for each RB allocation configuration is $>$ not $\frac{1}{2}$ dB higher than the same configuration in the largest supported bandwidth, and the reported SAR for the largest supported bandwidth is $\leq 1.45 W/kg$; Per KDB 941225 D05v02r02, smaller bandwidth SAR testing is not required.



<LTE Band 25 Conducted Power>

BW [MHz]	Modulation	RB Size	RB Offset	Power Low Ch. / Freq.	Power Middle Ch. / Freq.	Power High Ch. / Freq.	Tune up Limit (dBm)	Target MPR (dB)
Channel				26140	26365	26590		
Frequency (MHz)				1860	1882.5	1905		
20	QPSK	1	0	23.68	23.84	23.48	24.5	0
20	QPSK	1	49	23.25	23.65	23.43		
20	QPSK	1	99	23.05	23.36	22.86		
20	QPSK	50	0	22.17	22.51	22.10	23.5	1
20	QPSK	50	24	22.11	22.38	22.33		
20	QPSK	50	49	22.01	22.18	21.98		
20	QPSK	100	0	22.04	22.44	22.07	23.5	1
20	16QAM	1	0	23.07	22.54	22.05		
20	16QAM	1	49	22.50	22.49	22.02		
20	16QAM	1	99	22.52	22.41	21.78	22.5	2
20	16QAM	50	0	21.14	21.46	21.11		
20	16QAM	50	24	21.16	21.32	21.22		
20	16QAM	50	49	20.98	21.19	21.02	22.5	2
20	16QAM	100	0	21.06	21.33	21.05		
Channel				26115	26365	26615		
Frequency (MHz)				1857.5	1882.5	1907.5		
15	QPSK	1	0	23.65	23.79	23.45		
15	QPSK	1	37	23.33	23.75	23.44	24.5	0
15	QPSK	1	74	23.08	23.38	22.81		
15	QPSK	36	0	22.24	22.51	22.32		
15	QPSK	36	18	22.17	22.38	22.27	23.5	1
15	QPSK	36	37	22.09	22.32	21.85		
15	QPSK	75	0	21.99	22.36	21.95		
15	16QAM	1	0	23.06	22.67	22.35	23.5	1
15	16QAM	1	37	22.66	22.49	22.26		
15	16QAM	1	74	22.38	22.13	22.01		
15	16QAM	36	0	21.25	21.51	21.32	22.5	2
15	16QAM	36	18	21.23	21.36	21.28		
15	16QAM	36	37	21.09	21.29	20.84		
15	16QAM	75	0	21.10	21.33	20.97		
Channel				26090	26365	26640		
Frequency (MHz)				1855	1882.5	1910		
10	QPSK	1	0	23.57	23.78	23.45		
10	QPSK	1	24	23.44	23.56	23.12	24.5	0
10	QPSK	1	49	23.24	23.53	22.78		
10	QPSK	25	0	22.34	22.57	22.45		
10	QPSK	25	12	22.26	22.53	21.76	23.5	1
10	QPSK	25	24	22.11	22.47	21.80		
10	QPSK	50	0	22.19	22.34	21.88		
10	16QAM	1	0	22.51	22.56	22.41	23.5	1
10	16QAM	1	24	22.18	22.54	22.39		
10	16QAM	1	49	22.07	22.43	22.03		
10	16QAM	25	0	21.43	21.46	21.52	22.5	2
10	16QAM	25	12	21.38	21.49	21.08		
10	16QAM	25	24	21.24	21.48	20.80		
10	16QAM	50	0	21.17	21.29	20.83		



Channel				26065	26365	26665	Tune up Limit (dBm)	Target MPR (dB)
Frequency (MHz)				1852.5	1882.5	1912.5		
5	QPSK	1	0	23.66	23.59	23.03	24.5	0
5	QPSK	1	12	23.65	23.58	22.59		
5	QPSK	1	24	23.51	23.45	22.74		
5	QPSK	12	0	22.48	22.68	21.89	23.5	1
5	QPSK	12	6	22.47	22.57	21.75		
5	QPSK	12	11	22.49	22.59	21.68		
5	QPSK	25	0	22.39	22.43	21.75	23.5	1
5	16QAM	1	0	22.55	22.72	22.12		
5	16QAM	1	12	22.54	22.65	21.87		
5	16QAM	1	24	22.38	22.38	21.75	22.5	2
5	16QAM	12	0	21.47	21.68	20.92		
5	16QAM	12	6	21.55	21.58	20.85		
5	16QAM	12	11	21.58	21.65	20.79	22.5	2
5	16QAM	25	0	21.49	21.48	20.81		
Channel				26055	26365	26675	Tune up Limit (dBm)	Target MPR (dB)
Frequency (MHz)				1851.5	1882.5	1913.5		
3	QPSK	1	0	23.65	23.60	22.96	24.5	0
3	QPSK	1	7	23.56	23.47	22.68		
3	QPSK	1	14	23.36	23.40	22.80		
3	QPSK	8	0	22.55	22.51	21.83	23.5	1
3	QPSK	8	4	22.52	22.34	21.69		
3	QPSK	8	7	22.61	22.35	21.70		
3	QPSK	15	0	22.44	22.31	21.75	23.5	1
3	16QAM	1	0	22.77	22.55	22.86		
3	16QAM	1	7	22.46	22.49	21.84		
3	16QAM	1	14	22.29	22.31	21.95	22.5	2
3	16QAM	8	0	21.43	21.42	20.69		
3	16QAM	8	4	21.52	21.36	20.64		
3	16QAM	8	7	21.50	21.46	20.87	22.5	2
3	16QAM	15	0	21.53	21.62	20.71		
Channel				26047	26365	26683	Tune up Limit (dBm)	Target MPR (dB)
Frequency (MHz)				1850.7	1882.5	1914.3		
1.4	QPSK	1	0	23.53	23.51	22.57	24.5	0
1.4	QPSK	1	2	23.51	23.44	22.56		
1.4	QPSK	1	5	23.49	23.29	22.54		
1.4	QPSK	3	0	23.38	23.35	22.51	23.5	1
1.4	QPSK	3	1	23.47	23.30	22.53		
1.4	QPSK	3	2	23.50	23.37	22.51		
1.4	QPSK	6	0	22.54	22.30	21.69	23.5	1
1.4	16QAM	1	0	22.65	22.64	21.76		
1.4	16QAM	1	2	22.19	22.28	21.68		
1.4	16QAM	1	5	22.32	22.13	21.69	23.5	1
1.4	16QAM	3	0	22.54	22.49	21.68		
1.4	16QAM	3	1	22.64	22.46	21.64		
1.4	16QAM	3	2	22.62	22.37	21.63	22.5	2
1.4	16QAM	6	0	21.46	21.32	20.85		



<WLAN 2.4GHz Conducted Power>

WLAN 2.4GHz Band 802.11b Average Power (dBm)					
Channel	Frequency (MHz)	Data Rate (bps)			
		1M	2M	5.5M	11M
CH 01	2412	13.79	13.70	13.87	13.84
CH 06	2437	14.41	14.47	14.66	14.65
CH 11	2462	13.56	13.64	13.81	13.80

WLAN 2.4GHz Band 802.11g Average Power (dBm)									
Channel	Frequency (MHz)	Data Rate (bps)							
		6M	9M	12M	18M	24M	36M	48M	54M
CH 01	2412	11.94	12.03	12.10	12.03	12.32	12.19	12.26	12.31
CH 06	2437	12.77	12.83	12.77	12.89	13.10	13.02	13.06	13.18
CH 11	2462	12.01	12.04	12.13	12.15	12.32	12.25	12.29	12.34

WLAN 2.4GHz Band 802.11n (HT 20) Average Power (dBm)									
Channel	Frequency (MHz)	MCS Index							
		MCS0	MCS1	MCS2	MCS3	MCS4	MCS5	MCS6	MCS7
CH 01	2412	12.00	12.17	12.23	12.28	12.32	12.30	12.32	12.35
CH 06	2437	12.78	12.93	13.04	13.06	13.09	12.96	13.09	13.14
CH 11	2462	12.12	12.22	12.25	12.26	12.37	12.38	12.39	12.38

Note:

1. Per KDB 248227 D01 v01r02, choose the highest output power channel to test SAR and determine further SAR exclusion.
2. For each frequency band, testing at higher data rates and higher order modulations is not required when the maximum average output power for each of these configurations is less than 1/4dB higher than those measured at the lowest data rate.
3. Per KDB 248227 D01 v01r02, 11g and 11n-HT20 average output power is higher than 1/4dB higher than 11b mode, these modes SAR will be verified at the highest RF exposure position found in 802.11b (1Mbps & 5Mbps)SAR testing.

12. Antenna Location

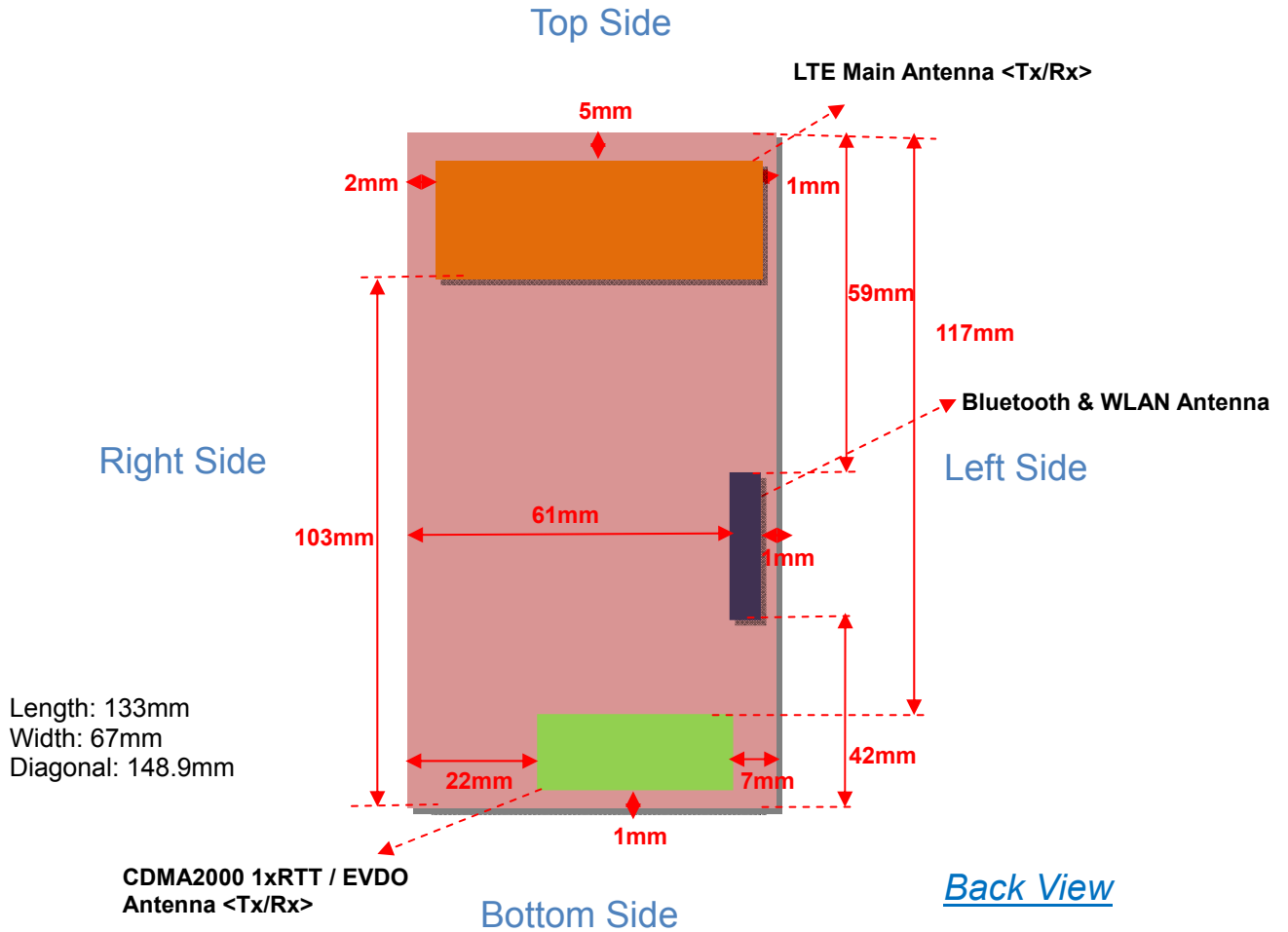

Antennas	Wireless Interface
LTE Main Antenna <Tx / Rx>	LTE Band 25
CDMA2000 1xRTT / EVDO <Tx / Rx>	CDMA2000 1xRTT and EV-DO BC0/BC1
WLAN & Bluetooth Antenna <Tx / Rx>	WLAN 2.4GHz, Bluetooth

Note:

1. This product has three antenna paths, one for LTE, one for 1xRTT and EVDO, and one for BT/WiFi.
2. The 1xRTT and EVDO share the same antenna path and cannot transmit simultaneously.
3. The Bluetooth and WLAN 2.4GHz share the same antenna path and cannot transmit simultaneously.



Distance of the Antenna to the EUT surface/edge Test distance: 10 mm						
Antennas	Back	Front	Top Side	Bottom Side	Right Side	Left Side
CDMA 1xRTT / EVDO	≤ 25mm	≤ 25mm	117mm	≤ 25mm	≤ 25mm	≤ 25mm
LTE	≤ 25mm	≤ 25mm	≤ 25mm	103mm	≤ 25mm	≤ 25mm
Bluetooth & WLAN	≤ 25mm	≤ 25mm	59mm	42mm	61mm	≤ 25mm

Positions for SAR tests; Hotspot mode Test distance: 10 mm						
Antennas	Back	Front	Top Side	Bottom Side	Right Side	Left Side
CDMA 1xRTT / EVDO	Yes	Yes	NO	Yes	Yes	Yes
LTE	Yes	Yes	Yes	NO	Yes	Yes
Bluetooth & WLAN	Yes	Yes	NO	NO	NO	Yes

Note:

1. Head/Body-worn/Hotspot mode SAR assessments are required.
2. Referring to KDB 941225 D06 v01r01, when the overall device length and width are ≥ 9cm*5cm, the test distance is 10 mm. SAR must be measured for all sides and surfaces with a transmitting antenna located within 25mm from that surface or edge
3. Per KDB 447498 D01v05r01, for handsets the *test separation distance* is determined by the smallest distance between the outer surface of the device and the user; which is 0mm for head SAR, 10mm for hotspot SAR, and 10mm for body-worn SAR.



13. SAR Test Results

Note:

1. Per KDB 447498 D01v05r01, the reported SAR is the measured SAR value adjusted for maximum tune-up tolerance.
 - a. Tune-up scaling Factor = tune-up limit power (mW) / EUT RF power (mW), where tune-up limit is the maximum rated power among all production units.
 - b. For SAR testing of WLAN signal with non-100% duty cycle, the measured SAR is scaled-up by the duty cycle scaling factor which is equal to "1/(duty cycle)"
 - c. For WWAN: Reported SAR(W/kg)= Measured SAR(W/kg)*Tune-up Scaling Factor
 - d. For WLAN: Reported SAR(W/kg)= Measured SAR(W/kg)* Duty Cycle scaling factor * Tune-up scaling factor
2. Per KDB 447498 D01v05r01, for each exposure position, if the highest output channel reported SAR ≤ 0.8 W/kg, other channels SAR testing is not necessary.
3. For Hotspot SAR testing, per KDB 941225 D06v01r01, for EUT dimension ≥ 9 cm*5cm, the test distance is 1cm. SAR must be measured for all surfaces and sides with a transmitting antenna located within 2.5cm from that surface or edge.
4. Considering the possibility of VOIP operation, LTE SAR for the head exposure positions and body-worn positions are performed.
5. Considering the possibility of VOIP operation, per KDB 941225 D01v02 1xEv-Do RevA (4096 bits) SAR for the head exposure positions and body-worn positions are performed.
6. Per KDB 941225 D05v02r02, when reported SAR of 1RB or 50%RB allocation for QPSK > 0.8 W/kg for any exposure position, SAR testing of 100%RB allocation for QPSK is performed at the highest power channel.
7. For QPSK with 100% RB allocation, if the reported SAR is > 1.45 W/kg, the remaining required test channels must be tested
8. 16QAM output power for each RB allocation configuration is $>$ not $\frac{1}{2}$ dB higher than the same configuration in QPSK and the reported SAR for the QPSK configuration is ≤ 1.45 W/kg; Per KDB 941225 D05v02, 16QAM SAR testing is not required.
9. Smaller bandwidth output power for each RB allocation configuration is $>$ not $\frac{1}{2}$ dB higher than the same configuration in the largest supported bandwidth, and the reported SAR for the largest supported bandwidth is ≤ 1.45 W/kg; Per KDB 941225 D05v02r02, smaller bandwidth SAR testing is not required.



13.1 Head SAR

<CDMA SAR>

Plot No.	Antenna	Band	Mode	Test Position	Ch.	Freq. (MHz)	Average Power (dBm)	Tune-Up Limit (dBm)	Scaling Factor	Power Drift (dB)	Measured SAR _{1g} (W/kg)	Reported SAR _{1g} (W/kg)
01	1xRTT/EVDO	CDMA2000 BC0	RC3 SO55	Right Cheek	1013	824.7	24.02	24.5	1.117	0.09	0.170	0.190
02	1xRTT/EVDO	CDMA2000 BC0	RC3 SO55	Right Tilted	1013	824.7	24.02	24.5	1.117	-0.05	0.124	0.138
03	1xRTT/EVDO	CDMA2000 BC0	RC3 SO55	Left Cheek	1013	824.7	24.02	24.5	1.117	-0.04	0.164	0.183
04	1xRTT/EVDO	CDMA2000 BC0	RC3 SO55	Left Tilted	1013	824.7	24.02	24.5	1.117	-0.02	0.116	0.130
05	1xRTT/EVDO	CDMA2000 BC0	RETAP 4096	Right Cheek	1013	824.7	23.80	24	1.047	0.04	0.142	0.149
151	1xRTT/EVDO	CDMA2000 BC1	RC3 SO55	Right Cheek	1175	1908.75	23.25	23.5	1.059	0.09	0.589	0.624
152	1xRTT/EVDO	CDMA2000 BC1	RC3 SO55	Right Tilted	1175	1908.75	23.25	23.5	1.059	0.07	0.144	0.153
153	1xRTT/EVDO	CDMA2000 BC1	RC3 SO55	Left Cheek	1175	1908.75	23.25	23.5	1.059	-0.02	0.460	0.487
154	1xRTT/EVDO	CDMA2000 BC1	RC3 SO55	Left Tilted	1175	1908.75	23.25	23.5	1.059	-0.02	0.257	0.272
155	1xRTT/EVDO	CDMA2000 BC1	RETAP 4096	Right Cheek	1175	1908.75	23.15	23.5	1.084	0.08	0.646	0.700

<LTE SAR>

Plot No.	Antenna	Band	Mode	BW (MHz)	RB Size	RB Offset	Test Position	Ch.	Freq. (MHz)	Average Power (dBm)	Tune-Up Limit (dBm)	Scaling Factor	Power Drift (dB)	Measured SAR _{1g} (W/kg)	Reported SAR _{1g} (W/kg)
31	LTE	LTE Band 25	QPSK	20	1	0	Right Cheek	26365	1882.5	23.84	24.5	1.164	0.04	0.040	0.047
32	LTE	LTE Band 25	QPSK	20	1	0	Right Tilted	26365	1882.5	23.84	24.5	1.164	0.06	0.025	0.029
33	LTE	LTE Band 25	QPSK	20	1	0	Left Cheek	26365	1882.5	23.84	24.5	1.164	-0.02	0.058	0.068
34	LTE	LTE Band 25	QPSK	20	1	0	Left Tilted	26365	1882.5	23.84	24.5	1.164	-0.02	0.042	0.049
41	LTE	LTE Band 25	QPSK	20	50	0	Right Cheek	26365	1882.5	22.51	23.5	1.256	0.08	0.021	0.026
42	LTE	LTE Band 25	QPSK	20	50	0	Right Tilted	26365	1882.5	22.51	23.5	1.256	0.06	0.020	0.025
43	LTE	LTE Band 25	QPSK	20	50	0	Left Cheek	26365	1882.5	22.51	23.5	1.256	0.01	0.047	0.059
44	LTE	LTE Band 25	QPSK	20	50	0	Left Tilted	26365	1882.5	22.51	23.5	1.256	-0.05	0.037	0.046

<WLAN2.4GHz SAR>

Plot No.	Antenna	Band	Mode	Test Position	Ch.	Freq. (MHz)	Average Power (dBm)	Tune-Up Limit (dBm)	Scaling Factor	Duty Cycle %	Duty Cycle Compensate Factor	Power Drift (dB)	Measured SAR _{1g} (W/kg)	Reported SAR _{1g} (W/kg)
141	WLAN/BT	WLAN 2.4GHz	802.11b, 1Mbps	Right Cheek	6	2437	14.41	15	1.146	97.60	1.025	0.03	0.097	0.113
142	WLAN/BT	WLAN 2.4GHz	802.11b, 1Mbps	Right Tilted	6	2437	14.41	15	1.146	97.60	1.025	-0.05	0.040	0.047
143	WLAN/BT	WLAN 2.4GHz	802.11b, 1Mbps	Left Cheek	6	2437	14.41	15	1.146	97.60	1.025	-0.03	0.190	0.223
144	WLAN/BT	WLAN 2.4GHz	802.11b, 1Mbps	Left Tilted	6	2437	14.41	15	1.146	97.60	1.025	-0.04	0.045	0.053
145	WLAN/BT	WLAN 2.4GHz	802.11b, 5.5Mbps	Left Cheek	6	2437	14.66	15	1.081	88.33	1.132	-0.03	0.211	0.258



13.2 Hotspot SAR

<CDMA SAR>

Plot No.	Antenna	Band	Mode	Test Position	Gap (cm)	Ch.	Freq. (MHz)	Average Power (dBm)	Tune-Up Limit (dBm)	Scaling Factor	Power Drift (dB)	Measured SAR _{1g} (W/kg)	Reported SAR _{1g} (W/kg)
21	1xRTT/EVDO	CDMA2000 BC0	RTAP 153.6	Front	1	1013	824.7	23.81	24	1.045	-0.03	0.211	0.220
22	1xRTT/EVDO	CDMA2000 BC0	RTAP 153.6	Back	1	1013	824.7	23.81	24	1.045	0.03	0.494	0.516
23	1xRTT/EVDO	CDMA2000 BC0	RTAP 153.6	Left Side	1	1013	824.7	23.81	24	1.045	0.06	0.227	0.237
24	1xRTT/EVDO	CDMA2000 BC0	RTAP 153.6	Right Side	1	1013	824.7	23.81	24	1.045	-0.10	0.216	0.226
25	1xRTT/EVDO	CDMA2000 BC0	RTAP 153.6	Bottom Side	1	1013	824.7	23.81	24	1.045	-0.08	0.053	0.055
101	1xRTT/EVDO	CDMA2000 BC1	RTAP 153.6	Front	1	1175	1908.75	23.24	23.5	1.062	-0.06	0.522	0.554
102	1xRTT/EVDO	CDMA2000 BC1	RTAP 153.6	Back	1	1175	1908.75	23.24	23.5	1.062	0.01	1.140	1.210
103	1xRTT/EVDO	CDMA2000 BC1	RTAP 153.6	Left Side	1	1175	1908.75	23.24	23.5	1.062	0.03	0.544	0.578
104	1xRTT/EVDO	CDMA2000 BC1	RTAP 153.6	Right Side	1	1175	1908.75	23.24	23.5	1.062	0.01	0.155	0.165
105	1xRTT/EVDO	CDMA2000 BC1	RTAP 153.6	Bottom Side	1	1175	1908.75	23.24	23.5	1.062	0.05	0.835	0.887
106	1xRTT/EVDO	CDMA2000 BC1	RTAP 153.6	Back	1	25	1851.25	23.23	23.5	1.064	0.09	1.450	1.543
107	1xRTT/EVDO	CDMA2000 BC1	RTAP 153.6	Back	1	600	1880	23.20	23.5	1.072	0.09	1.350	1.447
108	1xRTT/EVDO	CDMA2000 BC1	RTAP 153.6	Bottom Side	1	25	1851.25	23.23	23.5	1.064	-0.01	0.947	1.008
109	1xRTT/EVDO	CDMA2000 BC1	RTAP 153.6	Bottom Side	1	600	1880	23.20	23.5	1.072	0.05	1.030	1.104

<LTE SAR>

Plot No.	Antenna	Band	Mode	BW (MHz)	RB Size	RB Offset	Test Position	Gap (cm)	Ch.	Freq. (MHz)	Average Power (dBm)	Tune-Up Limit (dBm)	Scaling Factor	Power Drift (dB)	Measured SAR _{1g} (W/kg)	Reported SAR _{1g} (W/kg)
51	LTE	LTE Band 25	QPSK	20	1	0	Front	1	26365	1882.5	23.84	24.5	1.164	-0.10	0.572	0.666
52	LTE	LTE Band 25	QPSK	20	1	0	Back	1	26365	1882.5	23.84	24.5	1.164	0.09	1.020	1.187
53	LTE	LTE Band 25	QPSK	20	1	0	Left Side	1	26365	1882.5	23.84	24.5	1.164	-0.08	0.362	0.421
54	LTE	LTE Band 25	QPSK	20	1	0	Right Side	1	26365	1882.5	23.84	24.5	1.164	-0.01	0.580	0.675
55	LTE	LTE Band 25	QPSK	20	1	0	Top Side	1	26365	1882.5	23.84	24.5	1.164	-0.03	0.021	0.024
56	LTE	LTE Band 25	QPSK	20	1	0	Back	1	26140	1860	23.68	24.5	1.208	0.02	0.916	1.106
57	LTE	LTE Band 25	QPSK	20	1	0	Back	1	26590	1905	23.48	24.5	1.265	-0.09	0.917	1.160
71	LTE	LTE Band 25	QPSK	20	50	0	Front	1	26365	1882.5	22.51	23.5	1.256	-0.02	0.429	0.539
72	LTE	LTE Band 25	QPSK	20	50	0	Back	1	26365	1882.5	22.51	23.5	1.256	0.04	0.853	1.071
73	LTE	LTE Band 25	QPSK	20	50	0	Left Side	1	26365	1882.5	22.51	23.5	1.256	-0.09	0.280	0.352
74	LTE	LTE Band 25	QPSK	20	50	0	Right Side	1	26365	1882.5	22.51	23.5	1.256	-0.08	0.452	0.568
75	LTE	LTE Band 25	QPSK	20	50	0	Top Side	1	26365	1882.5	22.51	23.5	1.256	0.04	0.018	0.023
76	LTE	LTE Band 25	QPSK	20	50	0	Back	1	26140	1860	22.17	23.5	1.358	-0.01	0.690	0.937
77	LTE	LTE Band 25	QPSK	20	50	0	Back	1	26590	1905	22.10	23.5	1.380	-0.02	0.766	1.057
91	LTE	LTE Band 25	QPSK	20	100	0	Front	1	26365	1882.5	22.44	23.5	1.276	-0.03	0.373	0.476
92	LTE	LTE Band 25	QPSK	20	100	0	Back	1	26365	1882.5	22.44	23.5	1.276	-0.07	0.753	0.961
93	LTE	LTE Band 25	QPSK	20	100	0	Left Side	1	26365	1882.5	22.44	23.5	1.276	-0.02	0.260	0.332
94	LTE	LTE Band 25	QPSK	20	100	0	Right Side	1	26365	1882.5	22.44	23.5	1.276	-0.01	0.495	0.632
95	LTE	LTE Band 25	QPSK	20	100	0	Top Side	1	26365	1882.5	22.44	23.5	1.276	-0.02	0.019	0.024



<WLAN2.4GHz SAR>

Plot No.	Antenna	Band	Mode	Test Position	Gap (cm)	Ch.	Freq. (MHz)	Average Power (dBm)	Tune-Up Limit (dBm)	Scaling Factor	Duty Cycle %	Duty Cycle Compensate Factor	Power Drift (dB)	Measured SAR _{1g} (W/kg)	Reported SAR _{1g} (W/kg)
131	WLAN/BT	WLAN 2.4GHz	802.11b, 1Mbps	Front	1	6	2437	14.41	15	1.146	97.60	1.025	0.07	0.047	0.055
132	WLAN/BT	WLAN 2.4GHz	802.11b, 1Mbps	Back	1	6	2437	14.41	15	1.146	97.60	1.025	-0.05	0.109	0.128
133	WLAN/BT	WLAN 2.4GHz	802.11b, 1Mbps	Left Side	1	6	2437	14.41	15	1.146	97.60	1.025	0.01	0.072	0.085
134	WLAN/BT	WLAN 2.4GHz	802.11b, 5.5Mbps	Back	1	6	2437	14.66	15	1.081	88.33	1.132	0.06	0.097	0.119



13.3 Body Worn SAR

Note:

1. Body-worn SAR testing was performed at 10mm separation, and this distance is determined by the handset manufacturer that there will be body-worn accessories that users may acquire at the time of equipment certification, to enable users to purchase aftermarket body-worn accessories with the required minimum separation.
2. Per KDB 941225 D06v01r01, when the same wireless modes and device transmission configurations are required for testing body-worn accessories and hotspot mode, it is not necessary to test body-worn accessory SAR for the same device orientation if the test separation distance for hotspot mode is more conservative than that used for body-worn accessories.
3. Body-worn exposure conditions are intended to voice call operations, therefore GSM voice call mode is selected to be tested.
4. Though per KDB 648474 D04v01r01, when the reported SAR for a body-worn accessory measured without a headset connected to the handset is ≤ 1.2 W/kg, the SAR testing with a headset connected to the handset is not required, but considered the simultaneous SAR for body-worn, we still perform the WLAN SAR with headset mode.

<CDMA SAR>

Plot No.	Antenna	Band	Mode	Test Position	Gap (cm)	Headset	Ch.	Freq. (MHz)	Average Power (dBm)	Tune-Up Limit (dBm)	Scaling Factor	Power Drift (dB)	Measured SAR _{1g} (W/kg)	Reported SAR _{1g} (W/kg)
26	1xRTT/EVDO	CDMA2000 BC0	RC3 SO32	Front	1	-	1013	824.7	23.96	24	1.009	0.07	0.232	0.234
27	1xRTT/EVDO	CDMA2000 BC0	RC3 SO32	Back	1	-	1013	824.7	23.96	24	1.009	0.09	0.561	0.566
29	1xRTT/EVDO	CDMA2000 BC0	RETAP 4096	Back	1	-	1013	824.7	23.80	24	1.047	0.03	0.516	0.540
110	1xRTT/EVDO	CDMA2000 BC1	RC3 SO32	Front	1	-	1175	1908.75	23.16	23.5	1.081	0.02	0.524	0.567
111	1xRTT/EVDO	CDMA2000 BC1	RC3 SO32	Back	1	-	1175	1908.75	23.16	23.5	1.081	0.08	1.240	1.341
112	1xRTT/EVDO	CDMA2000 BC1	RC3 SO32	Back	1	-	25	1851.25	23.15	23.5	1.084	0.03	1.460	1.583
113	1xRTT/EVDO	CDMA2000 BC1	RC3 SO32	Back	1	-	600	1880	23.10	23.5	1.096	0.02	1.440	1.579
114	1xRTT/EVDO	CDMA2000 BC1	RC3 SO32	Back	1	Headset	1175	1908.75	23.16	23.5	1.081	0.02	1.240	1.341
115	1xRTT/EVDO	CDMA2000 BC1	RC3 SO32	Back	1	Headset	25	1851.25	23.15	23.5	1.084	0.07	1.120	1.214
116	1xRTT/EVDO	CDMA2000 BC1	RC3 SO32	Back	1	Headset	600	1880	23.10	23.5	1.096	0.04	1.350	1.480
118	1xRTT/EVDO	CDMA2000 BC1	RETAP 4096	Back	1	-	1175	1908.75	23.15	23.5	1.084	0.05	1.110	1.203
119	1xRTT/EVDO	CDMA2000 BC1	RETAP 4096	Back	1	-	25	1851.25	23.14	23.5	1.086	0.09	1.440	1.564
120	1xRTT/EVDO	CDMA2000 BC1	RETAP 4096	Back	1	-	600	1880	23.08	23.5	1.102	0.08	1.410	1.553
121	1xRTT/EVDO	CDMA2000 BC1	RETAP 4096	Back	1	Headset	1175	1908.75	23.15	23.5	1.084	0.04	1.050	1.138
122	1xRTT/EVDO	CDMA2000 BC1	RETAP 4096	Back	1	Headset	25	1851.25	23.14	23.5	1.086	0.04	1.290	1.401
123	1xRTT/EVDO	CDMA2000 BC1	RETAP 4096	Back	1	Headset	600	1880	23.08	23.5	1.102	0.03	1.320	1.454



<LTE SAR>

Plot No.	Antenna	Band	Mode	BW (MHz)	RB Size	RB Offset	Test Position	Gap (cm)	Headset	Ch.	Freq. (MHz)	Average Power (dBm)	Tune-Up Limit (dBm)	Scaling Factor	Power Drift (dB)	Measured SAR _{1g} (W/kg)	Reported SAR _{1g} (W/kg)
51	LTE	LTE Band 25	QPSK	20	1	0	Front	1	-	26365	1882.5	23.84	24.5	1.164	-0.10	0.572	0.666
52	LTE	LTE Band 25	QPSK	20	1	0	Back	1	-	26365	1882.5	23.84	24.5	1.164	0.09	1.020	1.187
56	LTE	LTE Band 25	QPSK	20	1	0	Back	1	-	26140	1860	23.68	24.5	1.208	0.02	0.916	1.106
57	LTE	LTE Band 25	QPSK	20	1	0	Back	1	-	26590	1905	23.48	24.5	1.265	-0.09	0.917	1.160
71	LTE	LTE Band 25	QPSK	20	50	0	Front	1	-	26365	1882.5	22.51	23.5	1.256	-0.02	0.429	0.539
72	LTE	LTE Band 25	QPSK	20	50	0	Back	1	-	26365	1882.5	22.51	23.5	1.256	0.04	0.853	1.071
76	LTE	LTE Band 25	QPSK	20	50	0	Back	1	-	26140	1860	22.17	23.5	1.358	-0.01	0.690	0.937
77	LTE	LTE Band 25	QPSK	20	50	0	Back	1	-	26590	1905	22.10	23.5	1.380	-0.02	0.766	1.057
91	LTE	LTE Band 25	QPSK	20	100	0	Front	1	-	26365	1882.5	22.44	23.5	1.276	-0.03	0.373	0.476
92	LTE	LTE Band 25	QPSK	20	100	0	Back	1	-	26365	1882.5	22.44	23.5	1.276	-0.07	0.753	0.961

<WLAN2.4GHz SAR>

Plot No.	Antenna	Band	Mode	Test Position	Gap (cm)	Headset	Ch.	Freq. (MHz)	Average Power (dBm)	Tune-Up Limit (dBm)	Scaling Factor	Duty Cycle %	Duty Cycle Compensate Factor	Power Drift (dB)	Measured SAR _{1g} (W/kg)	Reported SAR _{1g} (W/kg)
131	WLAN/BT	WLAN 2.4GHz	802.11b, 1Mbps	Front	1	-	6	2437	14.41	15	1.146	97.60	1.025	0.07	0.047	0.055
132	WLAN/BT	WLAN 2.4GHz	802.11b, 1Mbps	Back	1	-	6	2437	14.41	15	1.146	97.60	1.025	-0.05	0.109	0.128
134	WLAN/BT	WLAN 2.4GHz	802.11b, 5.5Mbps	Back	1		6	2437	14.66	15	1.081	88.33	1.132	0.06	0.097	0.119
135	WLAN/BT	WLAN 2.4GHz	802.11b, 1Mbps	Back	1	Headset	6	2437	14.41	15	1.146	97.60	1.025	0.05	0.095	0.111



13.4 Repeated SAR Measurement

Plot No.	Antenna	Band	Mode	Test Position	Gap (cm)	Headset	Ch.	Freq. (MHz)	Average Power (dBm)	Tune-Up Limit (dBm)	Scaling Factor	Power Drift (dB)	Measured SAR _{1g} (W/kg)	Ratio	Reported SAR _{1g} (W/kg)
112	1xRTT/EVDO	CDMA2000 BC1	RC3 SO32	Back	1	-	25	1851.25	23.15	23.5	1.084	0.03	1.460	1	1.583
124	1xRTT/EVDO	CDMA2000 BC1	RC3 SO32	Back	1	-	25	1851.25	23.15	23.5	1.084	0.06	1.440	1.014	1.561
125	1xRTT/EVDO	CDMA2000 BC1	RC3 SO32	Back	1	-	25	1851.25	23.15	23.5	1.084	0.04	1.430	1.021	1.550

Note:

1. Per KDB 865664 D01v01r01, for each frequency band, repeated SAR measurement is required only when the measured SAR is $\geq 0.8W/kg$.
2. Per KDB 865664 D01v01r01, Perform a second repeated measurement only if the ratio of largest to smallest SAR for the original and first repeated measurements is > 1.20 or when the original or repeated measurement is $\geq 1.45 W/kg$.
3. The ratio is the largest SAR to the smallest SAR among original and repeated measurement.
4. All measurement SAR result is scaled-up to account for tune-up tolerance and is compliant.

13.5 Highest SAR Plot

Test Laboratory: Sporton International Inc. SAR/HAC Testing Lab

Date: 2013.10.14

27 CDMA2000 BC0_RC3 SO32_Back_1cm_Ch1013

Communication System: CDMA2000; Frequency: 824.7 MHz; Duty Cycle: 1:1
 Medium: MSL_835_131014 Medium parameters used: $f = 825 \text{ MHz}$; $\sigma = 1.001 \text{ mho/m}$; $\epsilon_r = 56.355$;
 $\rho = 1000 \text{ kg/m}^3$
 Ambient Temperature : 23.5 °C; Liquid Temperature : 22.6 °C

DASY5 Configuration:

- Probe: EX3DV4 - SN3819; ConvF(9.5, 9.5, 9.5); Calibrated: 2012.11.26;
- Sensor-Surface: 2mm (Mechanical Surface Detection)
- Electronics: DAE4 Sn1303; Calibrated: 2012.11.22
- Phantom: SAM2; Type: QD000P40CD; Serial: TP:1671
- Measurement SW: DASY52, Version 52.8 (2); SEMCAD X Version 14.6.6 (6824)

Ch1013/Area Scan (61x111x1): Interpolated grid: dx=15mm, dy=15mm
 Maximum value of SAR (interpolated) = 0.751 W/kg

Ch1013/Zoom Scan (5x5x7)/Cube 0: Measurement grid: dx=8mm, dy=8mm, dz=5mm
 Reference Value = 2.294 V/m; Power Drift = 0.09 dB
 Peak SAR (extrapolated) = 0.910 mW/g
SAR(1 g) = 0.561 mW/g; SAR(10 g) = 0.393 mW/g
 Maximum value of SAR (measured) = 0.734 W/kg

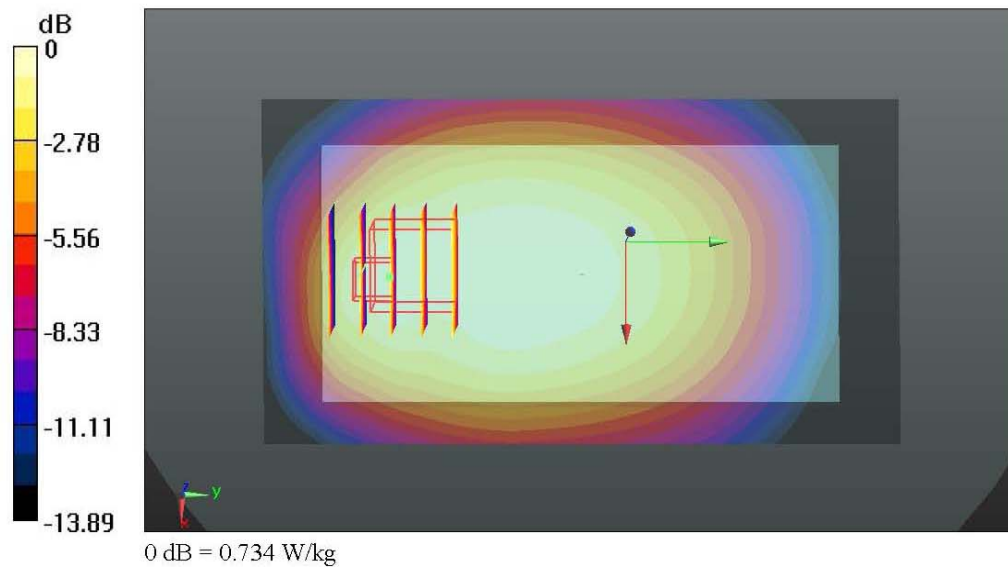

Test Laboratory: Sporton International Inc. SAR/HAC Testing Lab

Date: 2013.10.21

112 CDMA2000 BC1_RC3 SO32_Back_1cm_Ch25

Communication System: CDMA2000; Frequency: 1851.25 MHz; Duty Cycle: 1:1
 Medium: MSL_1900_131021 Medium parameters used: $f = 1851.25 \text{ MHz}$; $\sigma = 1.469 \text{ mho/m}$; $\epsilon_r = 54.84$; $\rho = 1000 \text{ kg/m}^3$
 Ambient Temperature : 23.5 °C ; Liquid Temperature : 22.7 °C

DASY5 Configuration:

- Probe: EX3DV4 - SN3819; ConvF(7.67, 7.67, 7.67); Calibrated: 2012.11.26;
- Sensor-Surface: 2mm (Mechanical Surface Detection)
- Electronics: DAE4 Sn1303; Calibrated: 2012.11.22
- Phantom: SAM1; Type: QD000P40CD; Serial: TP:1670
- Measurement SW: DASY52, Version 52.8 (2); SEMCAD X Version 14.6.6 (6824)

Ch25/Area Scan (61x111x1): Interpolated grid: dx=15mm, dy=15mm
 Maximum value of SAR (interpolated) = 1.83 W/kg

Ch25/Zoom Scan (5x5x7)/Cube 0: Measurement grid: dx=8mm, dy=8mm, dz=5mm
 Reference Value = 2.578 V/m; Power Drift = 0.03 dB
 Peak SAR (extrapolated) = 2.479 mW/g
SAR(1 g) = 1.460 mW/g; SAR(10 g) = 0.819 mW/g
 Maximum value of SAR (measured) = 1.99 W/kg

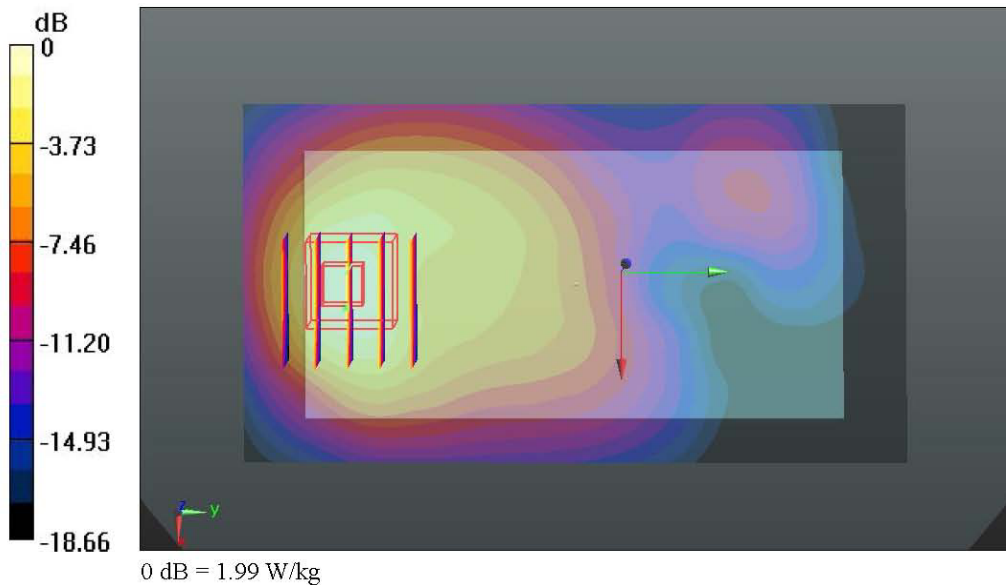

Test Laboratory: Sporton International Inc. SAR/HAC Testing Lab

Date: 2013.10.15

52 LTE Band 25_20M_QPSK 1Rb 0offset_Back_1cm_Ch26365

Communication System: LTE; Frequency: 1882.5 MHz; Duty Cycle: 1:1
 Medium: MSL_1900_131015 Medium parameters used: $f = 1882.5 \text{ MHz}$; $\sigma = 1.51 \text{ mho/m}$; $\epsilon_r = 54.723$; $\rho = 1000 \text{ kg/m}^3$
 Ambient Temperature : 23.5 °C ; Liquid Temperature : 22.7 °C

DASY5 Configuration:

- Probe: EX3DV4 - SN3819; ConvF(7.67, 7.67, 7.67); Calibrated: 2012.11.26;
- Sensor-Surface: 2mm (Mechanical Surface Detection)
- Electronics: DAE4 Sn1303; Calibrated: 2012.11.22
- Phantom: SAM1; Type: QD000P40CD; Serial: TP:1670
- Measurement SW: DASY52, Version 52.8 (2); SEMCAD X Version 14.6.6 (6824)

Ch26365/Area Scan (61x111x1): Interpolated grid: dx=15mm, dy=15mm

Maximum value of SAR (interpolated) = 1.28 W/kg

Ch26365/Zoom Scan (5x5x7)/Cube 0: Measurement grid: dx=8mm, dy=8mm, dz=5mm

Reference Value = 7.899 V/m; Power Drift = 0.09 dB

Peak SAR (extrapolated) = 1.803 mW/g

SAR(1 g) = 1.020 mW/g; SAR(10 g) = 0.578 mW/g

Maximum value of SAR (measured) = 1.36 W/kg

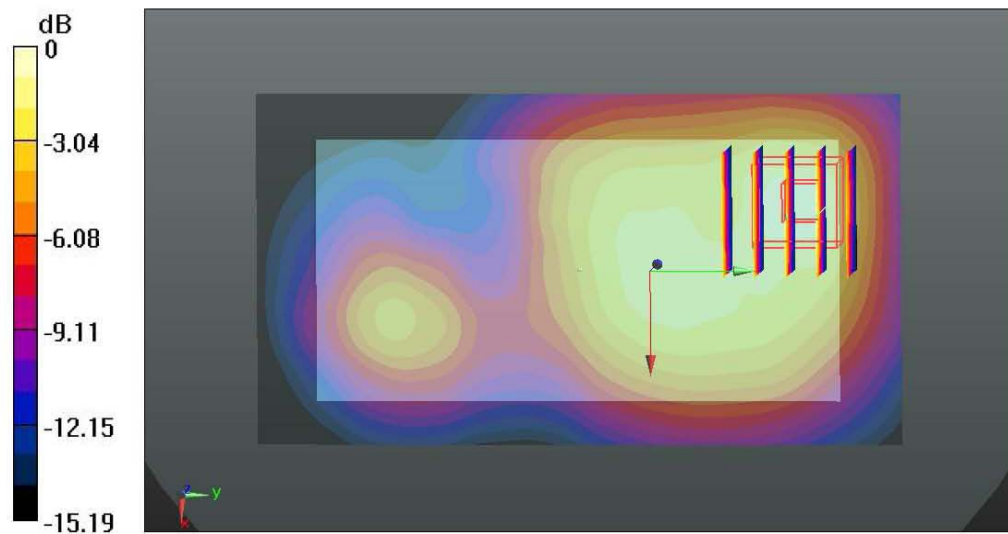

0 dB = 1.36 W/kg

Test Laboratory: Sporton International Inc. SAR/HAC Testing Lab

Date: 2013.10.22

145 WLAN2.4GHz_802.11b_5.5M_Left Check_Ch6

Communication System: WIFI; Frequency: 2437 MHz; Duty Cycle: 1:1.132
 Medium: HSL_2450_131022 Medium parameters used: $f = 2437 \text{ MHz}$; $\sigma = 1.863 \text{ mho/m}$; $\epsilon_r = 40.52$; $\rho = 1000 \text{ kg/m}^3$
 Ambient Temperature : 23.3 °C; Liquid Temperature : 22.6 °C

DASY5 Configuration:

- Probe: EX3DV4 - SN3819; ConvF(6.99, 6.99, 6.99); Calibrated: 2012.11.26;
- Sensor-Surface: 2mm (Mechanical Surface Detection)
- Electronics: DAE4 Sn1303; Calibrated: 2012.11.22
- Phantom: SAM1; Type: QD000P40CD; Serial: TP:1670
- Measurement SW: DASY52, Version 52.8 (2); SEMCAD X Version 14.6.6 (6824)

Ch6/Area Scan (81x131x1): Interpolated grid: dx=12mm, dy=12mm
 Maximum value of SAR (interpolated) = 0.315 W/kg

Ch6/Zoom Scan (7x7x7)/Cube 0: Measurement grid: dx=5mm, dy=5mm, dz=5mm
 Reference Value = 0.904 V/m; Power Drift = -0.03 dB
 Peak SAR (extrapolated) = 0.494 mW/g
SAR(1 g) = 0.211 mW/g; SAR(10 g) = 0.096 mW/g
 Maximum value of SAR (measured) = 0.325 W/kg

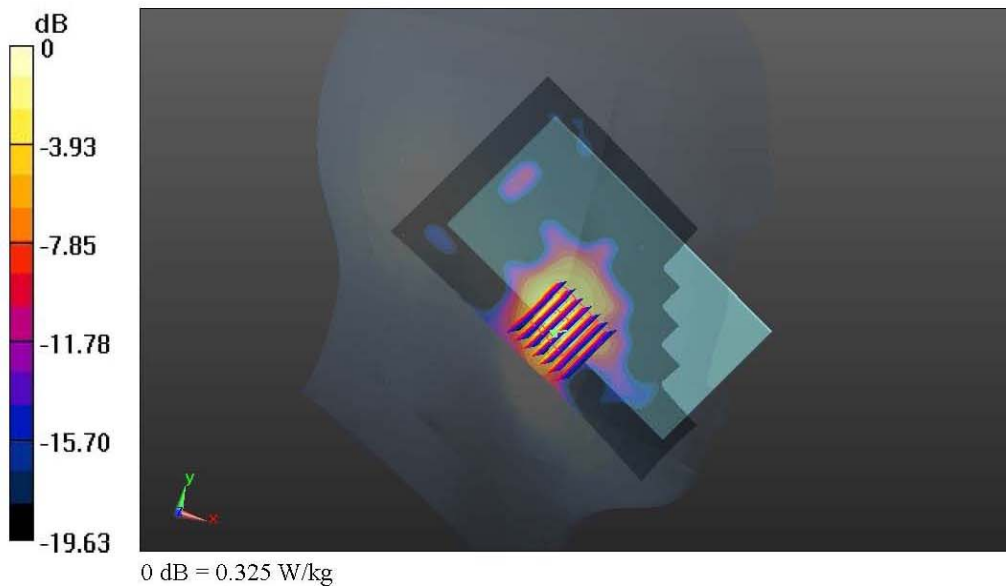

14. Simultaneous Transmission Analysis

NO.	Simultaneous Transmission Configurations	Phone			Note
		Head	Body-worn	Hotspot	
1.	CDMA(Voice) + WLAN2.4GHz(data)	Yes	Yes		
2.	CDMA(Voice) + Bluetooth(data)	Yes	Yes		
3.	CDMA(Data) + WLAN2.4GHz(data)			Yes	2.4GHz Hotspot
4.	LTE(Data) + WLAN2.4GHz(data)	Yes	Yes	Yes	2.4GHz Hotspot
5.	CDMA(Data) + Bluetooth(data)			Yes	Bluetooth Tethering
6.	LTE(Data) + Bluetooth(data)	Yes	Yes	Yes	Bluetooth Tethering

Note:

1. WLAN and Bluetooth share the same antenna, and cannot transmit simultaneously.
2. EUT will choose either CDMA/LTE according to the network signal condition; therefore, CDMA/LTE cannot transmit simultaneously.
3. The reported SAR summation is calculated based on the same configuration and test position.
4. Per KDB 447498 D01v05r01, simultaneous transmission SAR is compliant if,
 - i) Scalar SAR summation < 1.6W/kg.
 - ii) $SPLSR = (SAR_1 + SAR_2)^{1.5} / (min. separation distance, mm)$, and the peak separation distance is determined from the square root of $[(x_1-x_2)^2 + (y_1-y_2)^2 + (z_1-z_2)^2]$, where (x_1, y_1, z_1) and (x_2, y_2, z_2) are the coordinates of the extrapolated peak SAR locations in the zoom scan
If $SPLSR \leq 0.04$, simultaneously transmission SAR measurement is not necessary
 - iii) Simultaneously transmission SAR measurement, and the reported multi-band SAR < 1.6W/kg
5. For simultaneous transmission analysis, Bluetooth SAR is estimated per KDB 447498 D01v05r01 based on the formula below.
 - i) $(max. power of channel, including tune-up tolerance, mW) / (min. test separation distance, mm) \cdot [\sqrt{f(GHz)} / x] W/kg$ for test separation distances $\leq 50 mm$; where $x = 7.5$ for 1-g SAR, and $x = 18.75$ for 10-g SAR.
 - ii) When the minimum test separation distance is < 5mm, the distance is used 5mm to determine SAR test exclusion.
 - iii) 0.4 W/kg for 1-g SAR and 1.0 W/kg for 10-g SAR, when the test separation distances is > 50 mm.
 - iv) Bluetooth estimated SAR is conservatively determined by 5mm separation, for all applicable exposure positions.

In this report, 50mm separation is applied to conservatively estimate SAR value for separation distance > 50mm

Bluetooth Max Power (dBm)	Exposure Position	Head	Hotspot	Body worn
	Test separation	0 mm	10 mm	10 mm
2	Estimated SAR (W/kg)	0.067	0.033	0.033



14.1 Head Exposure Conditions

Position	WWAN (voice)			WLAN 2.4GHz		Summed SAR (W/kg)	SPLSR ≤ 0.04	Case No
	WWAN Band	Plot No	Max. WWAN SAR (W/kg)	Plot No	Max. WLAN SAR (W/kg)			
Right Cheek	CDMA2000 BC0	01	0.190	141	0.113	0.30		
	CDMA2000 BC1	155	0.700	141	0.113	0.81		
	LTE Band 25	31	0.047	141	0.113	0.16		
Right Tilted	CDMA2000 BC0	02	0.138	142	0.047	0.19		
	CDMA2000 BC1	152	0.153	142	0.047	0.20		
	LTE Band 25	32	0.029	142	0.047	0.08		
Left Cheek	CDMA2000 BC0	03	0.183	145	0.258	0.44		
	CDMA2000 BC1	153	0.487	145	0.258	0.75		
	LTE Band 25	33	0.068	145	0.258	0.33		
Left Tilted	CDMA2000 BC0	04	0.130	144	0.053	0.18		
	CDMA2000 BC1	154	0.272	144	0.053	0.33		
	LTE Band 25	34	0.049	144	0.053	0.10		

Position	WWAN (voice)			Bluetooth	Summed SAR (W/kg)	SPLSR ≤ 0.04	Case No
	WWAN Band	Plot No	Max. WWAN SAR (W/kg)	Estimated SAR (W/kg)			
Right Cheek	CDMA2000 BC0	01	0.190	0.067	0.26		
	CDMA2000 BC1	155	0.700	0.067	0.77		
	LTE Band 25	31	0.047	0.067	0.11		
Right Tilted	CDMA2000 BC0	02	0.138	0.067	0.21		
	CDMA2000 BC1	152	0.153	0.067	0.22		
	LTE Band 25	32	0.029	0.067	0.10		
Left Cheek	CDMA2000 BC0	03	0.183	0.067	0.25		
	CDMA2000 BC1	153	0.487	0.067	0.55		
	LTE Band 25	33	0.068	0.067	0.14		
Left Tilted	CDMA2000 BC0	04	0.130	0.067	0.20		
	CDMA2000 BC1	154	0.272	0.067	0.34		
	LTE Band 25	34	0.049	0.067	0.12		



14.2 Hotspot Exposure Conditions

Position	WWAN (data)			WLAN 2.4GHz		Summed SAR (W/kg)	SPLSR ≤ 0.04	Case No
	WWAN Band	Plot No	Max. WWAN SAR (W/kg)	Plot No	Max. WLAN SAR (W/kg)			
Front	CDMA2000 BC0	21	0.220	131	0.055	0.28		
	CDMA2000 BC1	101	0.554	131	0.055	0.61		
	LTE Band 25	51	0.666	131	0.055	0.72		
Back	CDMA2000 BC0	22	0.516	132	0.128	0.64		
	CDMA2000 BC1	106	1.543	132	0.128	1.67	0.04	1
	LTE Band 25	52	1.187	132	0.128	1.32		
Left Side	CDMA2000 BC0	23	0.237	133	0.085	0.32		
	CDMA2000 BC1	103	0.578	133	0.085	0.66		
	LTE Band 25	53	0.421	133	0.085	0.51		
Right Side	CDMA2000 BC0	24	0.226			0.23		
	CDMA2000 BC1	104	0.165			0.17		
	LTE Band 25	54	0.675			0.68		
Top Side	LTE Band 25	55	0.024			0.02		
Bottom Side	CDMA2000 BC0	25	0.055			0.06		
	CDMA2000 BC1	109	1.104			1.10		

Position	WWAN (data)			Bluetooth	Summed SAR (W/kg)	SPLSR ≤ 0.04	Case No
	WWAN Band	Plot No	Max. WWAN SAR (W/kg)	Estimated SAR (W/kg)			
Front	CDMA2000 BC0	21	0.220	0.033	0.25		
	CDMA2000 BC1	101	0.554	0.033	0.59		
	LTE Band 25	51	0.666	0.033	0.70		
Back	CDMA2000 BC0	22	0.516	0.033	0.55		
	CDMA2000 BC1	106	1.543	0.033	1.58		
	LTE Band 25	52	1.187	0.033	1.22		
Left Side	CDMA2000 BC0	23	0.237	0.033	0.27		
	CDMA2000 BC1	103	0.578	0.033	0.61		
	LTE Band 25	53	0.421	0.033	0.45		
Right Side	CDMA2000 BC0	24	0.226		0.23		
	CDMA2000 BC1	104	0.165		0.17		
	LTE Band 25	54	0.675		0.68		
Top Side	LTE Band25	55	0.024		0.02		
Bottom Side	CDMA2000 BC0	25	0.055		0.06		
	CDMA2000 BC1	109	1.104		1.10		



14.3 Body-Worn Exposure Conditions

Position	WWAN (voice)			WLAN 2.4GHz		Summed SAR (W/kg)	SPLSR ≤ 0.04	Case No
	WWAN Band	Plot No	Max. WWAN SAR (W/kg)	Plot No	Max. WLAN SAR (W/kg)			
Front	CDMA2000 BC0	26	0.234	131	0.055	0.29		
	CDMA2000 BC1	110	0.567	131	0.055	0.62		
	LTE Band 25	51	0.666	131	0.055	0.72		
Back	CDMA2000 BC0	27	0.566	132	0.128	0.69		
	CDMA2000 BC1	112	1.583	132	0.128	1.71	0.04	2
	LTE Band 25	52	1.187	132	0.128	1.32		
Back (with/Headset)	CDMA2000 BC1	116	1.480	135	0.111	1.59		

Position	WWAN (voice)			Bluetooth	Summed SAR (W/kg)	SPLSR ≤ 0.04	Case No
	WWAN Band	Plot No	Max. WWAN SAR (W/kg)	Estimated SAR (W/kg)			
Front	CDMA2000 BC0	26	0.234	0.033	0.27		
	CDMA2000 BC1	110	0.567	0.033	0.60		
	LTE Band 25	51	0.666	0.033	0.70		
Back	CDMA2000 BC0	27	0.566	0.033	0.60		
	CDMA2000 BC1	112	1.583	0.033	1.62	0.03	3
	LTE Band 25	52	1.187	0.033	1.22		
Back (with/Headset)	CDMA2000 BC1	116	1.480	0.033	1.51		

14.4 SPLSR Evaluation and Analysis

Plot No. 1	Band	Position	SAR (W/kg)	Gap (cm)	SAR peak location (m)			3D distance (mm)	Pair SAR sum (W/kg)	SPLSR	Simultaneous SAR
					X	Y	Z				
106	CDMA2000 BC1	Back	1.543	1	-0.0175	-0.054	-0.205	58.1	1.67	0.04	Not required
132	WLAN2.4GHz		0.128	1	0.004	0	-0.205				

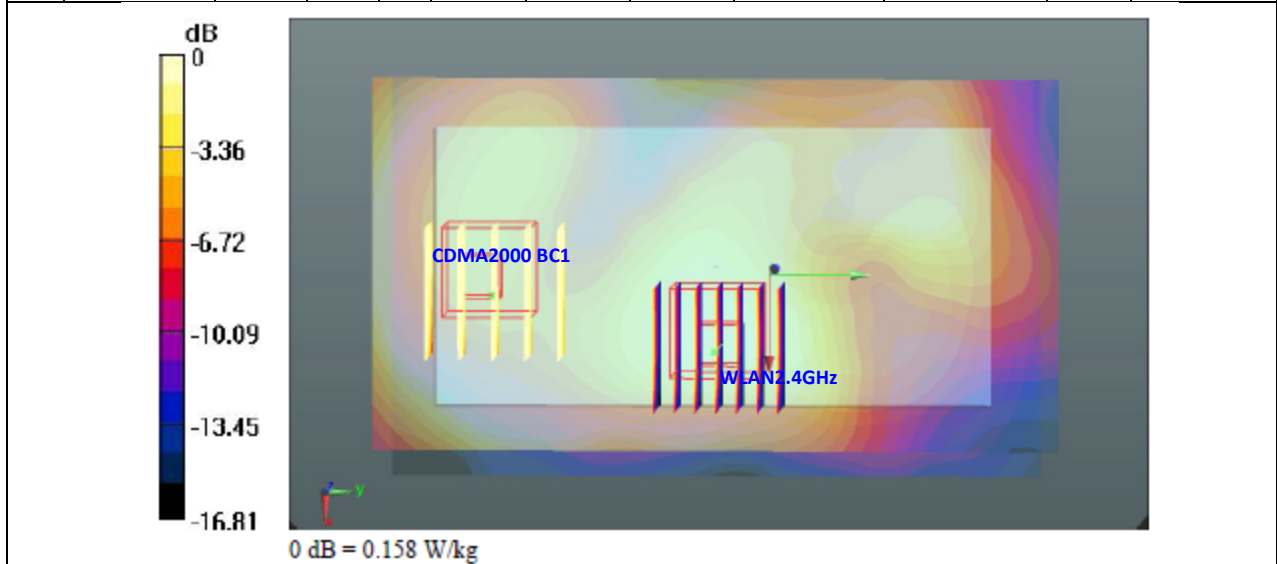

Plot No. 2	Band	Position	SAR (W/kg)	Gap (cm)	SAR peak location (m)			3D distance (mm)	Pair SAR sum (W/kg)	SPLSR	Simultaneous SAR
					X	Y	Z				
112	CDMA2000 BC1	Back	1.583	1	-0.019	-0.057	-0.205	61.5	1.71	0.04	Not required
132	WLAN2.4GHz		0.128	1	0.004	0	-0.205				

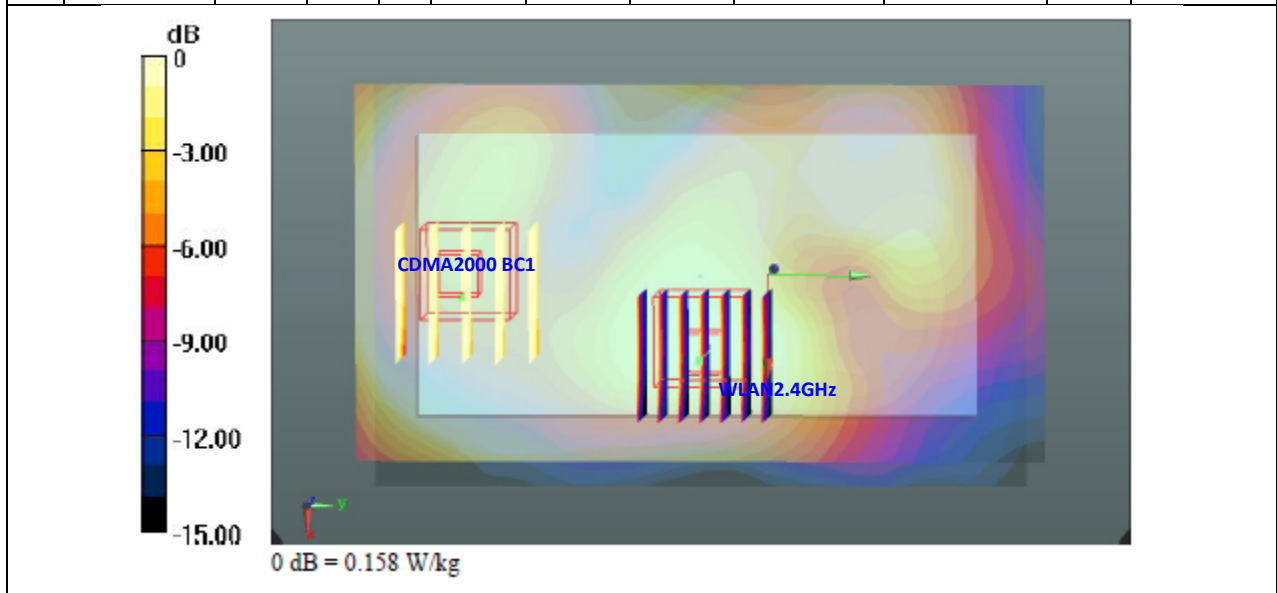

Plot No. 3	Band	Position	SAR (W/kg)	Gap (cm)	SAR peak location (m)			3D distance (mm)	Pair SAR sum (W/kg)	SPLSR	Simultaneous SAR
					X	Y	Z				
112	CDMA2000 BC1	Back	1.583	1	-0.019	-0.057	-0.205	61.5	1.62	0.03	Not required
-	Bluetooth		0.033	1	0.004	0	-0.205				

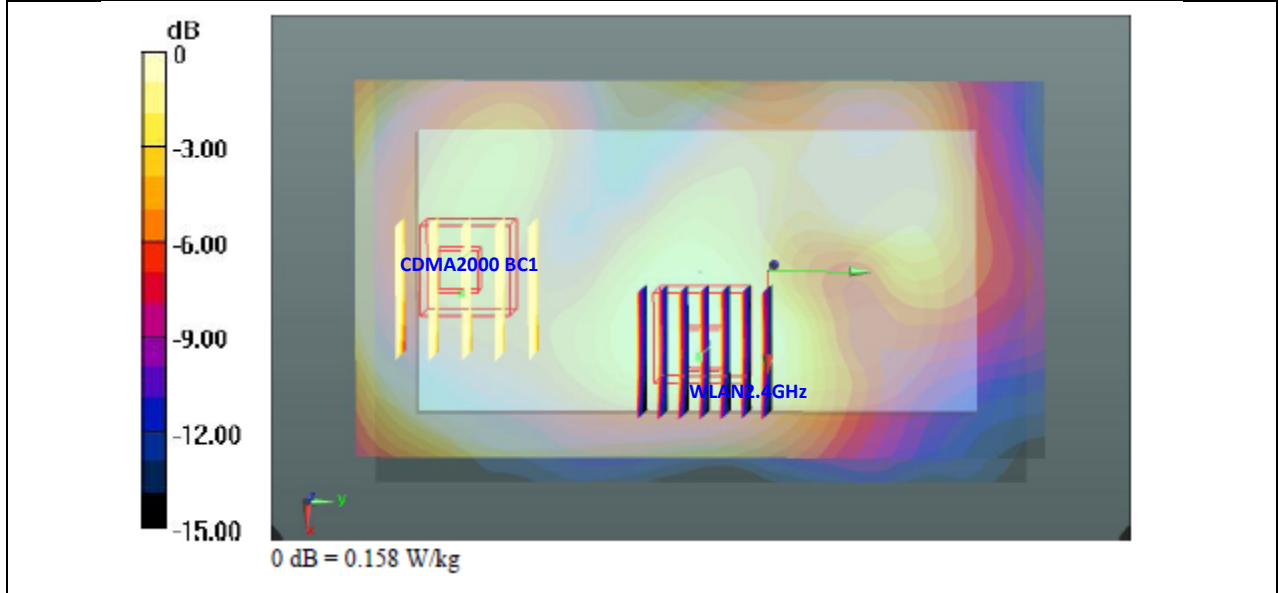

Remark: Per KDB 447498 D01v05r01, if SPLSR ≤ 0.04, further evaluation is not required.

Test Engineer : Luke Lu

15. Uncertainty Assessment

The component of uncertainty may generally be categorized according to the methods used to evaluate them. The evaluation of uncertainty by the statistical analysis of a series of observations is termed a Type A evaluation of uncertainty. The evaluation of uncertainty by means other than the statistical analysis of a series of observations is termed a Type B evaluation of uncertainty. Each component of uncertainty, however evaluated, is represented by an estimated standard deviation, termed standard uncertainty, which is determined by the positive square root of the estimated variance.

A Type A evaluation of standard uncertainty may be based on any valid statistical method for treating data. This includes calculating the standard deviation of the mean of a series of independent observations; using the method of least squares to fit a curve to the data in order to estimate the parameter of the curve and their standard deviations; or carrying out an analysis of variance in order to identify and quantify random effects in certain kinds of measurement.

A type B evaluation of standard uncertainty is typically based on scientific judgment using all of the relevant information available. These may include previous measurement data, experience, and knowledge of the behavior and properties of relevant materials and instruments, manufacture's specification, data provided in calibration reports and uncertainties assigned to reference data taken from handbooks. Broadly speaking, the uncertainty is either obtained from an outdoor source or obtained from an assumed distribution, such as the normal distribution, rectangular or triangular distributions indicated in Table 14.1

Uncertainty Distributions	Normal	Rectangular	Triangular	U-Shape
Multi-plying Factor ^(a)	1/k ^(b)	1/√3	1/√6	1/√2

(a) standard uncertainty is determined as the product of the multiplying factor and the estimated range of variations in the measured quantity

(b) κ is the coverage factor

Table 15.1. Standard Uncertainty for Assumed Distribution

The combined standard uncertainty of the measurement result represents the estimated standard deviation of the result. It is obtained by combining the individual standard uncertainties of both Type A and Type B evaluation using the usual "root-sum-squares" (RSS) methods of combining standard deviations by taking the positive square root of the estimated variances.

Expanded uncertainty is a measure of uncertainty that defines an interval about the measurement result within which the measured value is confidently believed to lie. It is obtained by multiplying the combined standard uncertainty by a coverage factor. Typically, the coverage factor ranges from 2 to 3. Using a coverage factor allows the true value of a measured quantity to be specified with a defined probability within the specified uncertainty range. For purpose of this document, a coverage factor two is used, which corresponds to confidence interval of about 95 %. The DASY uncertainty Budget is shown in the following tables.



Error Description	Uncertainty Value (±%)	Probability Distribution	Divisor	Ci (1g)	Ci (10g)	Standard Uncertainty (1g)	Standard Uncertainty (10g)
Measurement System							
Probe Calibration	6.0	Normal	1	1	1	± 6.0 %	± 6.0 %
Axial Isotropy	4.7	Rectangular	√3	0.7	0.7	± 1.9 %	± 1.9 %
Hemispherical Isotropy	9.6	Rectangular	√3	0.7	0.7	± 3.9 %	± 3.9 %
Boundary Effects	1.0	Rectangular	√3	1	1	± 0.6 %	± 0.6 %
Linearity	4.7	Rectangular	√3	1	1	± 2.7 %	± 2.7 %
System Detection Limits	1.0	Rectangular	√3	1	1	± 0.6 %	± 0.6 %
Readout Electronics	0.3	Normal	1	1	1	± 0.3 %	± 0.3 %
Response Time	0.8	Rectangular	√3	1	1	± 0.5 %	± 0.5 %
Integration Time	2.6	Rectangular	√3	1	1	± 1.5 %	± 1.5 %
RF Ambient Noise	3.0	Rectangular	√3	1	1	± 1.7 %	± 1.7 %
RF Ambient Reflections	3.0	Rectangular	√3	1	1	± 1.7 %	± 1.7 %
Probe Positioner	0.4	Rectangular	√3	1	1	± 0.2 %	± 0.2 %
Probe Positioning	2.9	Rectangular	√3	1	1	± 1.7 %	± 1.7 %
Max. SAR Eval.	1.0	Rectangular	√3	1	1	± 0.6 %	± 0.6 %
Test Sample Related							
Device Positioning	2.9	Normal	1	1	1	± 2.9 %	± 2.9 %
Device Holder	3.6	Normal	1	1	1	± 3.6 %	± 3.6 %
Power Drift	5.0	Rectangular	√3	1	1	± 2.9 %	± 2.9 %
Phantom and Setup							
Phantom Uncertainty	4.0	Rectangular	√3	1	1	± 2.3 %	± 2.3 %
Liquid Conductivity (Target)	5.0	Rectangular	√3	0.64	0.43	± 1.8 %	± 1.2 %
Liquid Conductivity (Meas.)	2.5	Normal	1	0.64	0.43	± 1.6 %	± 1.1 %
Liquid Permittivity (Target)	5.0	Rectangular	√3	0.6	0.49	± 1.7 %	± 1.4 %
Liquid Permittivity (Meas.)	2.5	Normal	1	0.6	0.49	± 1.5 %	± 1.2 %
Combined Standard Uncertainty						± 11.0 %	± 10.8 %
Coverage Factor for 95 %						K=2	
Expanded Uncertainty						± 22.0 %	± 21.5 %

Table 15.2. Uncertainty Budget for frequency range 300 MHz to 3 GHz



16. References

- [1] FCC 47 CFR Part 2 “Frequency Allocations and Radio Treaty Matters; General Rules and Regulations”
- [2] ANSI/IEEE Std. C95.1-1992, “IEEE Standard for Safety Levels with Respect to Human Exposure to Radio Frequency Electromagnetic Fields, 3 kHz to 300 GHz”, September 1992
- [3] IEEE Std. 1528-2003, “Recommended Practice for Determining the Peak Spatial-Average Specific Absorption Rate (SAR) in the Human Head from Wireless Communications Devices: Measurement Techniques”, December 2003
- [4] SPEAG DASY System Handbook
- [5] FCC KDB 248227 D01 v01r02, “SAR Measurement Procedures for 802.11 a/b/g Transmitters”, May 2007
- [6] FCC KDB 447498 D01 v05r01, “Mobile and Portable Device RF Exposure Procedures and Equipment Authorization Policies”, May 2013
- [7] FCC KDB 648474 D04 v01r01, “SAR Evaluation Considerations for Wireless Handsets”, May 2013
- [8] FCC KDB 941225 D05 v02r02, “SAR Evaluation Considerations for LTE Devices”, May 2013
- [9] FCC KDB 941225 D01 v02, “SAR Measurement Procedures for 3G Devices – CDMA 2000 / Ev-Do / WCDMA / HSDPA / HSPA”, October 2007
- [10] FCC KDB 941225 D06 v01r01, "SAR Evaluation Procedures for Portable Devices with Wireless Router Capabilities", May 2013
- [11] FCC KDB 865664 D01 v01r01, "SAR Measurement Requirements for 100 MHz to 6 GHz", May 2013.
- [12] FCC KDB 865664 D02 v01r01, “RF Exposure Compliance Reporting and Documentation Considerations”, May 2013