

FCC/IC Test Report

APPLICANT : Yulong Computer Telecommunication Scientific
(Shenzhen) Co., Ltd.

EQUIPMENT : mobile phone

BRAND NAME : Coolpad

MODEL NAME : Coolpad 801E

FCC ID : R38YL801E

IC : 10367A-YL801E

STANDARD : FCC 47 CFR FCC Part 15 Subpart B
ICES-003 Issue 5

CLASSIFICATION : Certification

The product was received on Jan. 16, 2013 and completely tested on Jan. 25, 2013. We, SPORTON INTERNATIONAL (KUNSHAN) INC., would like to declare that the tested sample has been evaluated in accordance with the procedures given in ANSI C63.4-2003 and shown the compliance with the applicable technical standards.

The test results in this report apply exclusively to the tested model / sample. Without written approval of SPORTON INTERNATIONAL (KUNSHAN) INC., the test report shall not be reproduced except in full.

Reviewed by:



Jones Tsai / Manager



SPORTON INTERNATIONAL (KUNSHAN) INC.
No. 3-2, PingXiang Road, Kunshan, Jiangsu Province, P.R.C.



TABLE OF CONTENTS

REVISION HISTORY..... 3

SUMMARY OF TEST RESULT 4

1. GENERAL DESCRIPTION 5

 1.1. Applicant..... 5

 1.2. Manufacturer 5

 1.3. Feature of Equipment Under Test..... 5

 1.4. Product Specification of Equipment Under Test 6

 1.5. Test Site 7

 1.6. Applied Standards 7

2. TEST CONFIGURATION OF EQUIPMENT UNDER TEST 8

 2.1. Test Mode 8

 2.2. Connection Diagram of Test System 11

 2.3. Support Unit used in test configuration and system..... 13

 2.4. Test Software 14

3. TEST RESULT..... 15

 3.1. Test of AC Conducted Emission Measurement 15

 3.2. Test of Radiated Emission Measurement 21

4. LIST OF MEASURING EQUIPMENT 25

5. UNCERTAINTY OF EVALUATION 26

APPENDIX A. PHOTOGRAPHS OF EUT

APPENDIX B. SETUP PHOTOGRAPHS



SUMMARY OF TEST RESULT

Report Section	FCC Rule	IC Rule	Description	Limit	Result	Remark
3.1	15.107	7.2.4	AC Conducted Emission	< 15.107 limits < RSS-Gen table 2 limits	PASS	Under limit 9.32 dB at 0.490 MHz
3.2	15.109	7.2.3.2	Radiated Emission	< 15.109 limits or < RSS-Gen table 1 limits (Section 6)	PASS	Under limit 9.30 dB at 601.330 MHz



1. General Description

1.1. Applicant

Yulong Computer Telecommunication Scientific (Shenzhen) Co., Ltd.
Hi-Tech Industry Park(North), Nanshan District, Shenzhen City, Guangdong Province, P.R.C

1.2. Manufacturer

Yulong Computer Telecommunication Scientific (Shenzhen) Co., Ltd.
Hi-Tech Industry Park(North), Nanshan District, Shenzhen City, Guangdong Province, P.R.C

1.3. Feature of Equipment Under Test

Product Feature	
Equipment	mobile phone
Brand Name	Coolpad
Model Name	Coolpad 801E
FCC ID	R38YL801E
IC	10367A-YL801E
EUT supports Radios application	CDMA/EV-DO/ LTE/WLAN 11bgn/ Bluetooth/Bluetooth4.0 - LE
HW Version	P0
SW Version	4.1.012.P0.130105.QC1
EUT Stage	Identical Prototype

Remark: The above EUT's information was declared by manufacturer. Please refer to the specifications or user's manual for more detailed description.

1.4. Product Specification of Equipment Under Test

Product Specification subjective to this standard	
Tx Frequency	CDMA2000 BC0: 824.70 MHz ~ 848.31 MHz CDMA2000 BC1: 1851.25 MHz ~ 1908.75 MHz CDMA2000 BC15: 1711.25 MHz ~ 1753.75 MHz LTE Band 2: 1850.7 MHz ~ 1909.3 MHz LTE Band 4: 1710.7 MHz ~ 1754.3 MHz LTE Band 12: 699.7 MHz ~ 715.3 MHz LTE Band 25: 1850.7 MHz ~ 1914.3 MHz 802.11b/g/n: 2412 MHz ~ 2462 MHz Bluetooth: 2402 MHz ~ 2480 MHz
Rx Frequency Range	CDMA2000 BC0: 869.70 MHz ~ 893.31 MHz CDMA2000 BC1: 1931.25 MHz ~ 1988.75 MHz CDMA2000 BC15 : 2111.25 MHz ~ 2153.75 MHz LTE Band 2: 1930.7 MHz ~ 1989.3 MHz LTE Band 4: 2110.7 MHz ~ 2154.3 MHz LTE Band 12: 729.7 MHz ~ 745.3 MHz LTE Band 25: 1930.7 MHz ~ 1994.3 MHz 802.11b/g/n: 2412 MHz ~ 2462 MHz Bluetooth: 2402 MHz ~ 2480 MHz GPS : 1.57542 GHz
Antenna Type	WWAN : PIFA Antenna LTE : PIFA Antenna WLAN : PIFA Antenna Bluetooth : PIFA Antenna
Type of Modulation	CDMA2000 : QPSK CDMA2000 1xEV-DO : 8PSK LTE : QPSK / 16QAM / 64QAM (Uplink) 802.11b : DSSS (DBPSK / DQPSK / CCK) 802.11g/n : OFDM (BPSK / QPSK / 16QAM / 64QAM) Bluetooth BDR (1Mbps) : GFSK Bluetooth EDR (2Mbps) : $\pi/4$ -DQPSK Bluetooth EDR (3Mbps) : 8-DPSK Bluetooth v4.0 - LE: GFSK GPS : BPSK

1.5. Test Site

Test Site	SPORTON INTERNATIONAL (KUNSHAN) INC.		
Test Site Location	No. 3-2, PingXiang Road, Kunshan, Jiangsu Province, P.R.C. TEL: +86-0512-5790-0158 FAX: +86-0512-5790-0958		
Test Site No.	Sporton Site No.		FCC/IC Registration No.
	CO01-KS	03CH01-KS	149928/4086E-1

1.6. Applied Standards

According to the specifications of the manufacturer, the EUT must comply with the requirements of the following standards:

- FCC 47 CFR FCC Part 15 Subpart B
- IC ICES-003 Issue 5
- ANSI C63.4-2003
- IC RSS-Gen Issue 3

Remark:

1. All test items were verified and recorded according to the standards and without any deviation during the test.
2. The test results for FCC compliance, indicating that these results are deemed satisfactory evidence of compliance with **Industry Canada Interference-Causing Equipment Standard ICES-003**.

2. Test Configuration of Equipment Under Test

2.1. Test Mode

The EUT has been associated with peripherals pursuant to ANSI C63.4-2003 and configuration operated in a manner tended to maximize its emission characteristics in a typical application.

Frequency range investigated: conduction (150 KHz to 30 MHz), radiation (30MHz to the 5th harmonic of the highest fundamental frequency or to 40 GHz, whichever is lower).

The following tables are showing the test modes as the worst cases and recorded in this report.

Item	EUT Configuration	Test Condition		
		EMI AC	EMI RE<1G	EMI RE≥1G
1.	Charging Mode (EUT with adapter)	☒	☒	Note 1
2.	Data application transferred mode (EUT with PC)	☒	☒	☒

Abbreviations:

- EMI AC: AC conducted emissions
- EMI RE ≥ 1G: EUT radiated emissions ≥ 1GHz
- EMI RE < 1G: EUT radiated emissions < 1GHz

Note 1: Testing for this mode is not required or not the worst case.

Remark: For signal above 1GHz, the worst case was test item 2.

Test Items	EUT Configure Mode	Function Type
AC Conducted Emission	1/2	<p>Mode 1: CDMA2000 BC0 Idle + Bluetooth Idle + WLAN Idle + USB Cable (Charging from Adapter) + Camera <Fig. 1></p> <p>Mode 2: CDMA2000 BC1 Idle + Bluetooth Idle + WLAN Idle + USB Cable (Charging from Adapter) + MP3 <Fig. 1></p> <p>Mode 3: CDMA2000 BC15 Idle + Bluetooth Idle + WLAN Idle + USB Cable (Data Link with PC) + GPS Rx <Fig. 2></p> <p>Mode 4: LTE Band 4 Idle + Bluetooth Idle + WLAN Idle + USB Cable (Charging from Adapter) + Camera <Fig. 3></p> <p>Mode 5: LTE Band 12 Idle + Bluetooth Idle + WLAN Idle + USB Cable (Charging from Adapter) + MP3 <Fig. 3></p> <p>Mode 6: LTE Band 25 Idle + Bluetooth Idle + WLAN Idle + USB Cable (Charging from Adapter) + GPS Rx <Fig. 4></p> <p>Mode 7: LTE Band 2 Idle + Bluetooth Idle + WLAN Idle + USB Cable (Charging from Adapter) + Camera <Fig. 3></p>
Radiated Emissions < 1GHz	1/2	<p>Mode 1: CDMA2000 BC0 Idle + Bluetooth Idle + WLAN Idle + USB Cable (Charging from Adapter) + Camera <Fig. 1></p> <p>Mode 2: CDMA2000 BC1 Idle + Bluetooth Idle + WLAN Idle + USB Cable (Charging from Adapter) + MP3 <Fig. 1></p> <p>Mode 3: CDMA2000 BC15 Idle + Bluetooth Idle + WLAN Idle + USB Cable (Data Link with PC) + GPS Rx <Fig. 2></p> <p>Mode 4: LTE Band 4 Idle + Bluetooth Idle + WLAN Idle + USB Cable (Charging from Adapter) + Camera <Fig. 3></p> <p>Mode 5: LTE Band 12 Idle + Bluetooth Idle + WLAN Idle + USB Cable (Charging from Adapter) + MP3 <Fig. 3></p> <p>Mode 6: LTE Band 25 Idle + Bluetooth Idle + WLAN Idle + USB Cable (Charging from Adapter) + GPS Rx <Fig. 4></p> <p>Mode 7: LTE Band 2 Idle + Bluetooth Idle + WLAN Idle + USB Cable (Charging from Adapter) + Camera <Fig. 3></p>
Radiated Emissions ≥ 1GHz	2	<p>Mode 1: CDMA2000 BC15 Idle + Bluetooth Idle + WLAN Idle + USB Cable (Data Link with PC) + GPS Rx <Fig. 2></p>

Remark:

1. The worst case of AC Conducted Emission is mode 2; the test data of this mode was reported.
2. The USB Link mode of AC Conducted Emission is mode 3; the test data of this mode was reported.
3. The worst case of Radiated Emissions is mode 3; only the test data of this mode was reported.
4. Link with PC means data application transferred mode between EUT and PC.

2.2. Connection Diagram of Test System

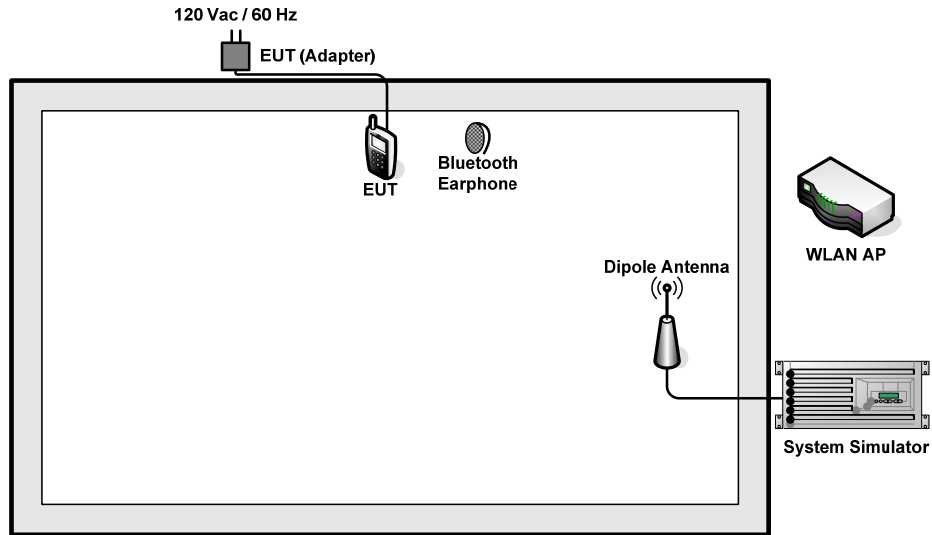

<Fig. 1>

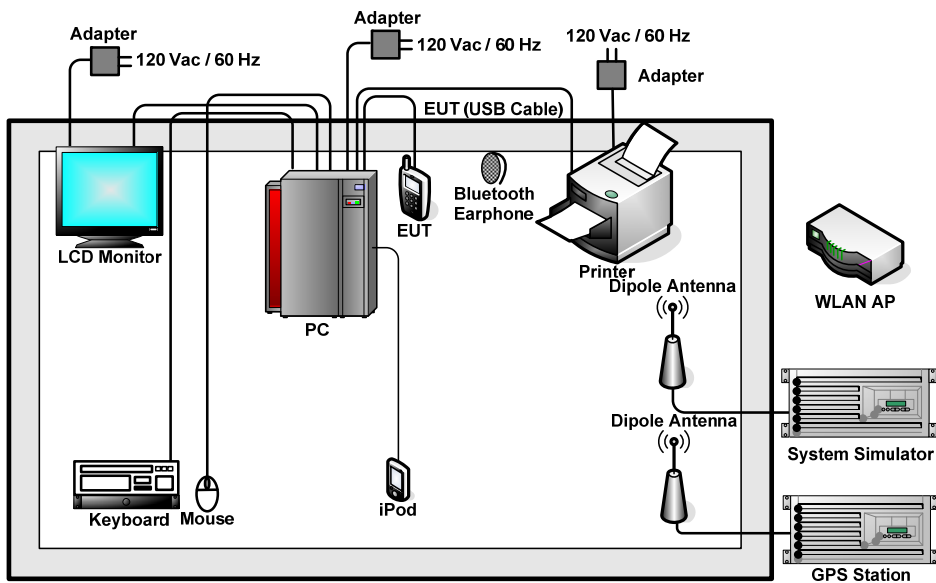

<Fig. 2>

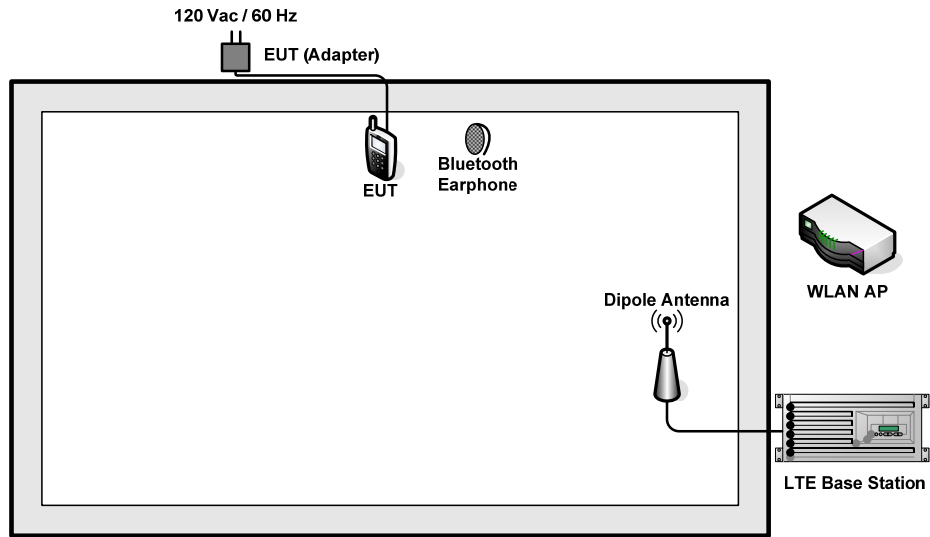

<Fig. 3>

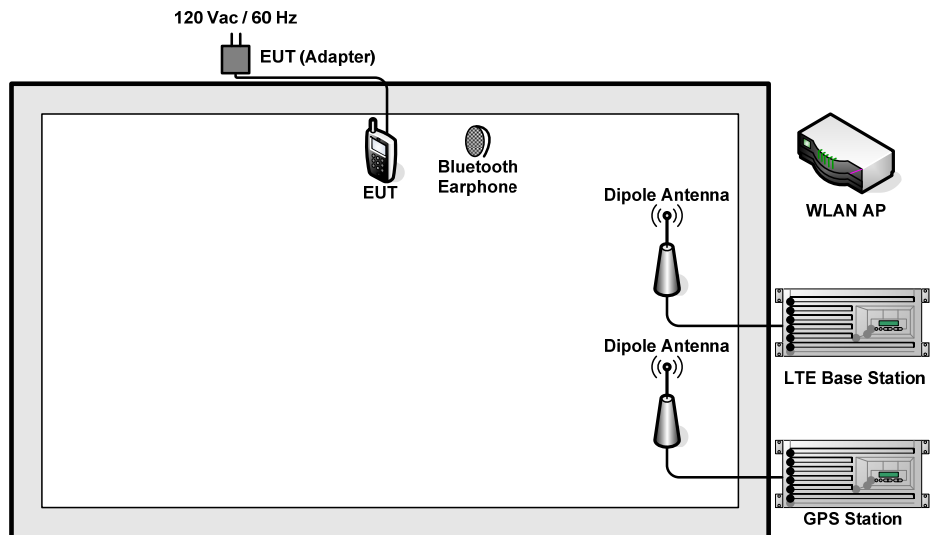

<Fig. 4>

2.3. Support Unit used in test configuration and system

Item	Equipment	Trade Name	Model Name	FCC ID	Data Cable	Power Cord
1.	System Simulator	R&S	CMU 200	N/A	N/A	Unshielded, 1.8 m
2.	LTE Base Station	Anritsu	MT8820C	N/A	N/A	Unshielded, 1.8 m
3.	GPS Station	ADIVIC	MP9000	N/A	N/A	Unshielded, 1.8 m
4.	WLAN AP	D-Link	DIR-855	KA2DIR855A2	N/A	Unshielded, 1.8 m
5.	Bluetooth Earphone	Nokia	BH-102	PYAHS-107W	N/A	N/A
6.	Bluetooth Earphone	Nokia	BH-106	QTLBH-106	N/A	N/A
7.	PC	DELL	DCSM	FCC DoC	N/A	Unshielded, 1.8 m
8.	PC	DELL	MT320	FCC DoC	N/A	Unshielded, 1.8 m
9.	Monitor	DELL	E1910Hc	FCC DoC	Shielded, 1.2 m	Unshielded, 1.8 m
10.	Printer	HP	Laser Jet 1018	FCC DoC	Shielded, 1.8 m	Unshielded, 1.8 m
11.	(USB)Mouse	DELL	MO56UC	FCC DoC	Shielded, 1.8 m	N/A
12.	(USB)Mouse	DELL	N231	FCC DoC	Shielded, 1.8 m	N/A
13.	(USB)Keyboard	DELL	SK-8115	FCC DoC	Shielded, 1.8 m with Core	N/A
14.	iPod	Apple	A1199	FCC DoC	Shielded, 1.2 m	N/A



2.4. Test Software

The EUT was in CDMA2000 or LTE idle mode during the testing. The EUT was synchronized to the BCCH, and is in continuous receiving mode by setting system simulator's paging reorganization.

At the same time, the EUT was attached to the Bluetooth earphone or WLAN AP, and the following programs installed in the EUT were programmed during the test.

1. Execute the program, "Winthrax" under WIN7 installed in PC for files transfer with EUT via USB cable.
2. Turn on GPS function to make the EUT receive continuous signals from GPS station.
3. Execute "Music Player" to play MP3 file.
4. Turn on camera to capture images.
5. Execute "H Pattern" to show H Pattern via VGA Cable on the Monitor.

3. Test Result

3.1. Test of AC Conducted Emission Measurement

3.1.1 Limits of AC Conducted Emission

For equipment that is designed to be connected to the public utility (AC) power line, the radio frequency voltage that is conducted back onto the AC power line on any frequency or frequencies within the band 150 KHz to 30 MHz shall not exceed the limits in the following table.

Frequency of emission (MHz)	Conducted limit (dBuV)	
	Quasi-peak	Average
0.15-0.5	66 to 56*	56 to 46*
0.5-5	56	46
5-30	60	50

*Decreases with the logarithm of the frequency.

3.1.2 Measuring Instruments

See list of measuring instruments of this test report.

3.1.3 Test Procedure

1. The EUT was placed 0.4 meter from the conducting wall of the shielding room was kept at least 80 centimeters from any other grounded conducting surface.
2. Connect EUT to the power mains through a line impedance stabilization network (LISN).
3. All the support units are connecting to the other LISN.
4. The LISN provides 50 ohm coupling impedance for the measuring instrument.
5. The FCC states that a 50 ohm, 50 microhenry LISN should be used.
6. Both sides of AC line were checked for maximum conducted interference.
7. The frequency range from 150 KHz to 30 MHz was searched.
8. Set the test-receiver system to Peak Detect Function and specified bandwidth with Maximum Hold Mode.

3.1.4 Test Setup

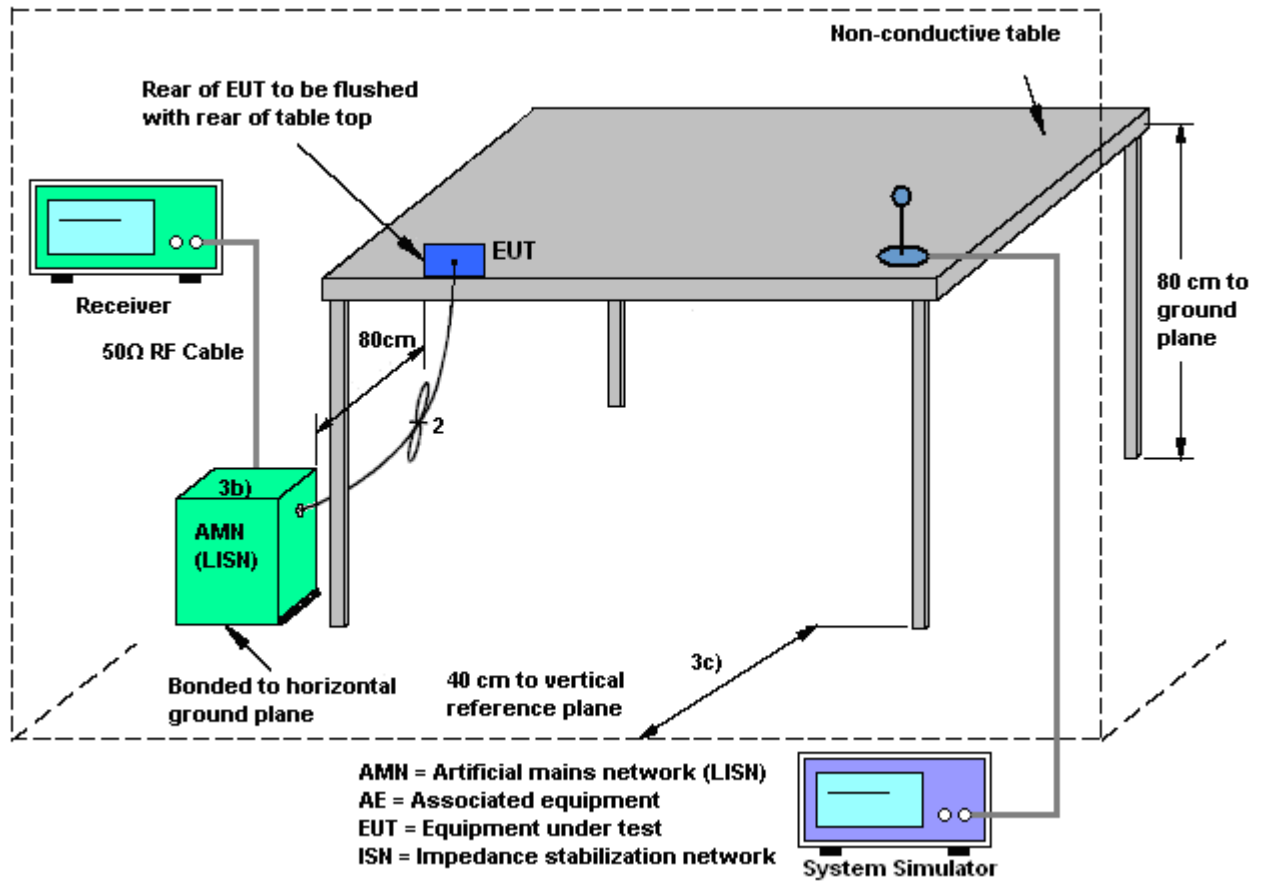



3.1.5 Test Result of AC Conducted Emission

Test Mode :	Mode 2	Temperature :	19~20°C
Test Engineer :	Tom Wang	Relative Humidity :	39~40%
Test Voltage :	120Vac / 60Hz	Phase :	Line
Function Type :	CDMA2000 BC1 Idle + Bluetooth Idle + WLAN Idle + USB Cable (Charging from Adapter) + MP3		
Remark :	All emissions not reported here are more than 10 dB below the prescribed limit.		

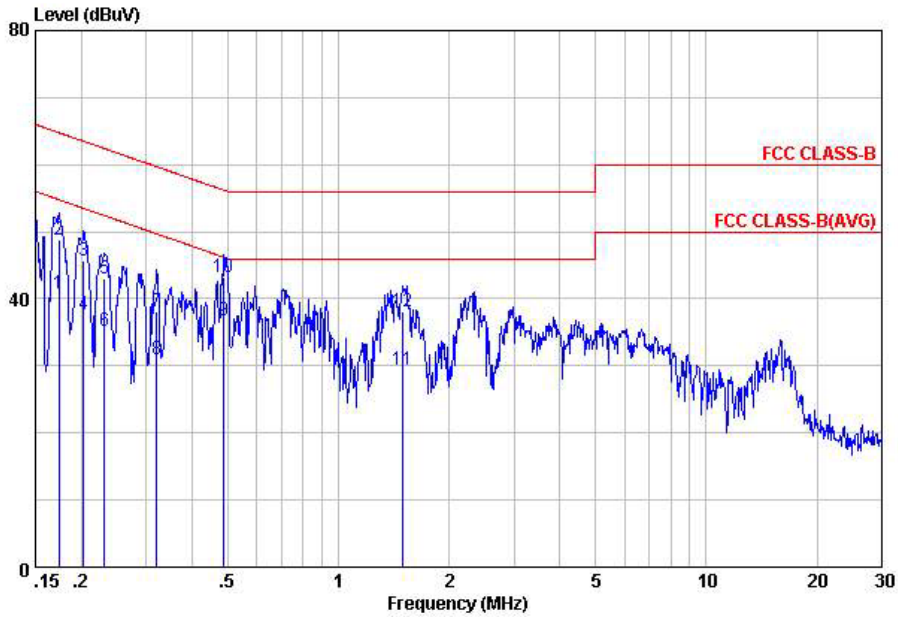

Site : C001-KS
 Condition: FCC CLASS-B LISN-111230 LINE
 Project : (FC) 311602
 mode : Mode 2

	Freq	Level	Over	Limit	Read	LISN	Cable	Remark
	MHz	dBuV	Limit	Line	Level	Factor	Loss	
			dB	dBuV	dBuV	dB	dB	
1	0.17	40.84	-13.93	54.77	30.70	-0.07	10.21	Average
2	0.17	48.84	-15.93	64.77	38.70	-0.07	10.21	QP
3	0.20	45.75	-17.74	63.49	35.60	-0.07	10.22	QP
4	0.20	37.65	-15.84	53.49	27.50	-0.07	10.22	Average
5	0.23	42.95	-19.44	62.39	32.80	-0.07	10.22	QP
6	0.23	35.15	-17.24	52.39	25.00	-0.07	10.22	Average
7	0.32	38.07	-21.64	59.71	27.91	-0.08	10.24	QP
8	0.32	30.97	-18.74	49.71	20.81	-0.08	10.24	Average
9	0.49	36.87	-9.32	46.19	26.70	-0.08	10.25	Average
10	0.49	43.27	-12.92	56.19	33.10	-0.08	10.25	QP
11	1.50	29.39	-16.61	46.00	19.21	-0.11	10.29	Average
12	1.50	38.19	-17.81	56.00	28.01	-0.11	10.29	QP



Test Mode :	Mode 2	Temperature :	19~20°C
Test Engineer :	Tom Wang	Relative Humidity :	39~40%
Test Voltage :	120Vac / 60Hz	Phase :	Neutral
Function Type :	CDMA2000 BC1 Idle + Bluetooth Idle + WLAN Idle + USB Cable (Charging from Adapter) + MP3		
Remark :	All emissions not reported here are more than 10 dB below the prescribed limit.		

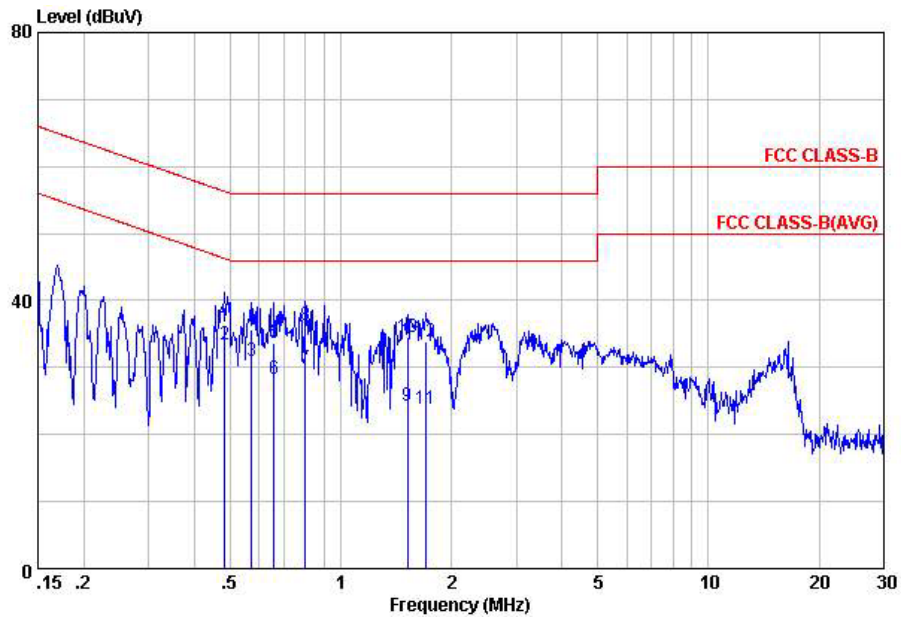

Site : C001-KS
 Condition: FCC CLASS-B LISN-111230 NEUTRAL
 Project : (FC) 311602
 mode : Mode 2

	Freq	Level	Over	Limit	Read	LISN	Cable	Remark
	MHz	dBuV	Limit	Line	Level	Factor	Loss	
			dB	dBuV	dBuV	dB	dB	
1	0.48	36.17	-20.10	56.27	26.00	-0.08	10.25	QP
2	0.48	33.37	-12.90	46.27	23.20	-0.08	10.25	Average
3	0.57	31.08	-14.92	46.00	20.90	-0.08	10.26	Average
4	0.57	35.58	-20.42	56.00	25.40	-0.08	10.26	QP
5	0.66	33.69	-22.31	56.00	23.50	-0.08	10.27	QP
6	0.66	28.29	-17.71	46.00	18.10	-0.08	10.27	Average
7	0.80	29.89	-26.11	56.00	19.69	-0.08	10.28	Average
8	0.80	36.29	-19.71	56.00	26.09	-0.08	10.28	QP
9	1.52	24.29	-21.71	46.00	14.10	-0.10	10.29	Average
10	1.52	34.49	-21.51	56.00	24.30	-0.10	10.29	QP
11	1.71	23.89	-22.11	46.00	13.70	-0.11	10.30	Average
12	1.71	33.79	-22.21	56.00	23.60	-0.11	10.30	QP



Test Mode :	Mode 3	Temperature :	19~20°C
Test Engineer :	Tom Wang	Relative Humidity :	39~40%
Test Voltage :	120Vac / 60Hz	Phase :	Line
Function Type :	CDMA2000 BC15 Idle + Bluetooth Idle + WLAN Idle + USB Cable (Data Link with PC) + GPS Rx		
Remark :	All emissions not reported here are more than 10 dB below the prescribed limit.		

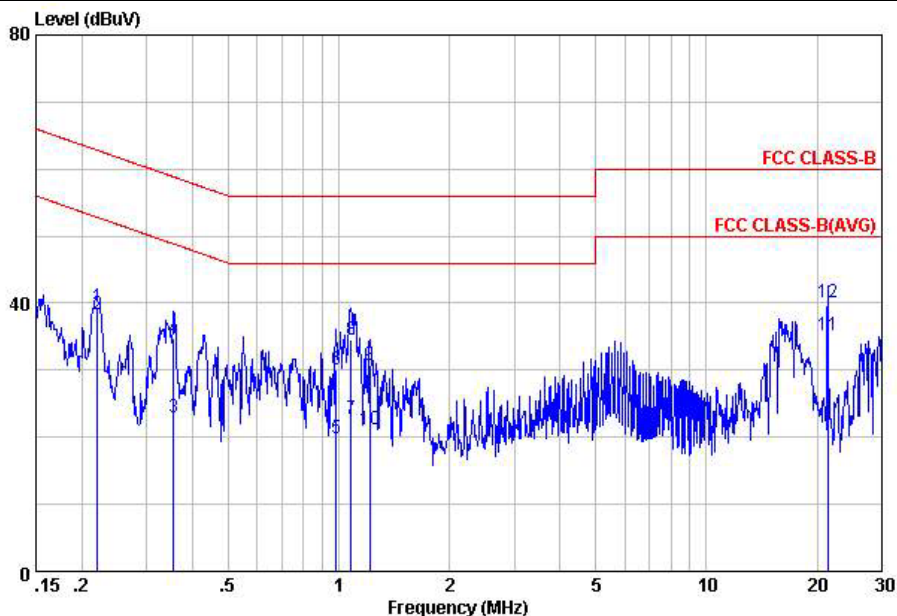

Site : C001-KS
 Condition: FCC CLASS-B LISN-111230 LINE
 Project : (FC) 311602
 mode : Mode 3

	Freq	Level	Over	Limit	Read	LISN	Cable	Remark
	MHz	dBuV	Limit	Line	Level	Factor	Loss	
			dB	dBuV	dBuV	dB	dB	
1	0.22	39.35	-23.44	62.79	29.20	-0.07	10.22	QP
2	0.22	38.35	-14.44	52.79	28.20	-0.07	10.22	Average
3	0.36	22.87	-25.96	48.83	12.70	-0.08	10.25	Average
4	0.36	34.87	-23.96	58.83	24.70	-0.08	10.25	QP
5	0.98	19.88	-26.12	46.00	9.70	-0.10	10.28	Average
6	0.98	29.98	-26.02	56.00	19.80	-0.10	10.28	QP
7	1.08	22.78	-23.22	46.00	12.60	-0.10	10.28	Average
8	1.08	34.58	-21.42	56.00	24.40	-0.10	10.28	QP
9	1.22	30.68	-25.32	56.00	20.50	-0.10	10.28	QP
10	1.22	21.08	-24.92	46.00	10.90	-0.10	10.28	Average
11	21.37	35.20	-14.80	50.00	24.60	0.09	10.51	Average
12	21.37	40.10	-19.90	60.00	29.50	0.09	10.51	QP



Test Mode :	Mode 3	Temperature :	19~20°C
Test Engineer :	Tom Wang	Relative Humidity :	39~40%
Test Voltage :	120Vac / 60Hz	Phase :	Neutral
Function Type :	CDMA2000 BC15 Idle + Bluetooth Idle + WLAN Idle + USB Cable (Data Link with PC) + GPS Rx		
Remark :	All emissions not reported here are more than 10 dB below the prescribed limit.		

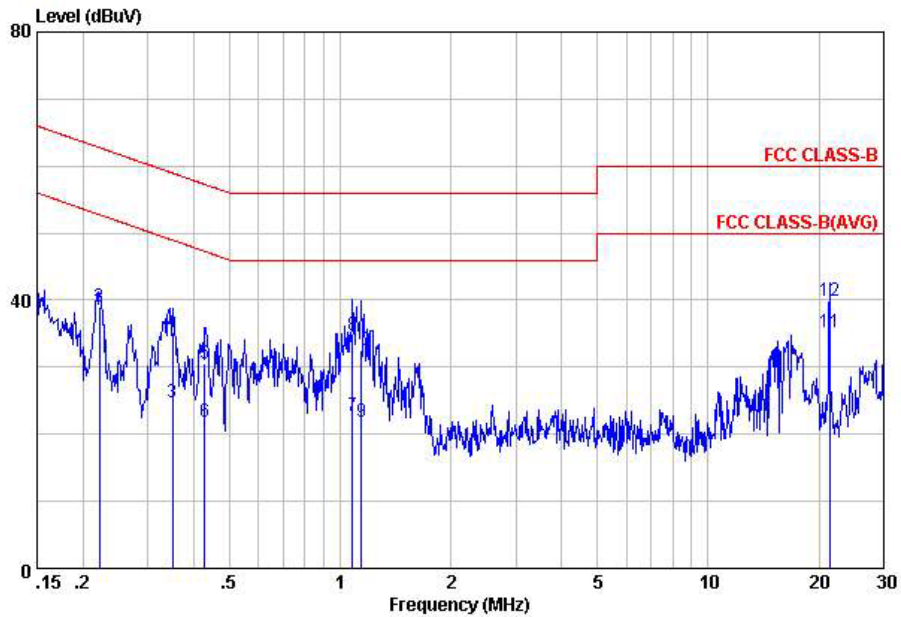

Site : C001-KS
 Condition: FCC CLASS-B LISN-111230 NEUTRAL
 Project : (FC) 311602
 mode : Mode 3

	Freq	Level	Over	Limit	Read	LISN	Cable	Remark
	MHz	dBuV	dB	dBuV	dBuV	dB	dB	
1	0.22	38.65	-14.09	52.74	28.50	-0.07	10.22	Average
2	0.22	39.05	-23.69	62.74	28.90	-0.07	10.22	QP
3	0.35	24.77	-24.19	48.96	14.60	-0.08	10.25	Average
4	0.35	35.17	-23.79	58.96	25.00	-0.08	10.25	QP
5	0.43	30.57	-26.72	57.29	20.40	-0.08	10.25	QP
6	0.43	21.77	-25.52	47.29	11.60	-0.08	10.25	Average
7	1.08	22.79	-23.21	46.00	12.60	-0.09	10.28	Average
8	1.08	34.69	-21.31	56.00	24.50	-0.09	10.28	QP
9	1.14	21.89	-24.11	46.00	11.70	-0.09	10.28	Average
10	1.14	32.59	-23.41	56.00	22.40	-0.09	10.28	QP
11	21.37	35.18	-14.82	50.00	24.60	0.07	10.51	Average
12	21.37	39.98	-20.02	60.00	29.40	0.07	10.51	QP

3.2. Test of Radiated Emission Measurement

3.2.1. Limit of Radiated Emission

The emissions from an unintentional radiator shall not exceed the field strength levels specified in the following table:

Frequency (MHz)	Field Strength (microvolts/meter)	Measurement Distance (meters)
30 – 88	100	3
88 – 216	150	3
216 - 960	200	3
Above 960	500	3

3.2.2. Measuring Instruments

See list of measuring instruments of this test report.

3.2.3. Test Procedures

1. The EUT was placed on a turntable with 0.8 meter above ground.
2. The EUT was set 3 meters from the interference receiving antenna, which was mounted on the top of a variable height antenna tower.
3. The table was rotated 360 degrees to determine the position of the highest radiation.
4. The antenna height is adjusted between one to four meters above ground to find the maximum value of the field strength for both horizontal polarization and vertical polarization of the antenna.
5. For each suspected emission, the EUT was arranged to its worst case and then tune the antenna tower (from 1 m to 4 m) and turntable (from 0 degree to 360 degrees) to find the maximum reading.
6. Set the test-receiver system to Peak Detect Function and specified bandwidth with Maximum Hold Mode.
7. If the emission level of the EUT in peak mode was 3 dB lower than the limit specified, peak values of EUT will be reported. Otherwise, the emission will be repeated by using the quasi-peak method and reported.
8. Emission level (dBuV/m) = 20 log Emission level (uV/m)
9. Corrected Reading: Antenna Factor + Cable Loss + Read Level - Preamp Factor= Level

3.2.4. Test Setup of Radiated Emission

For radiated emissions from 30MHz to 1GHz

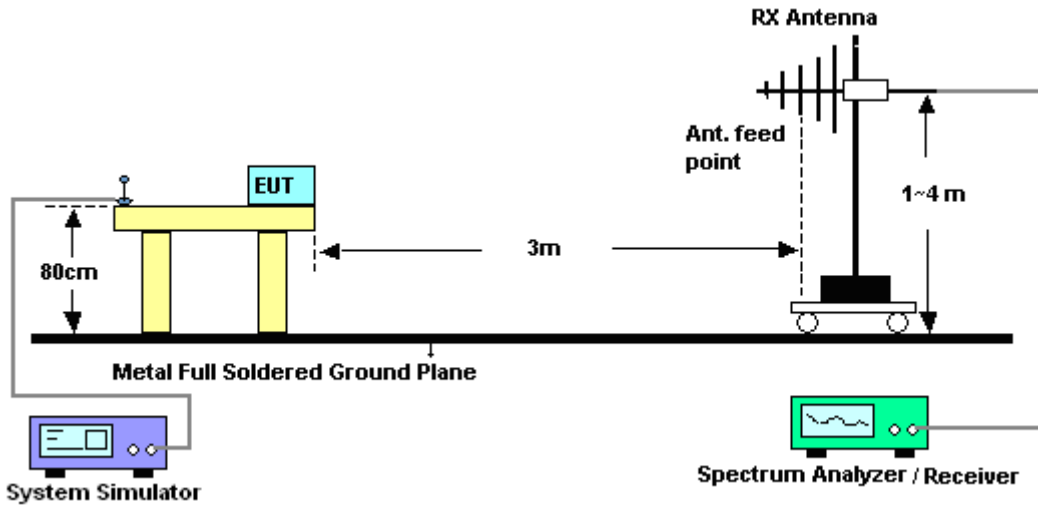

For radiated emissions above 1GHz

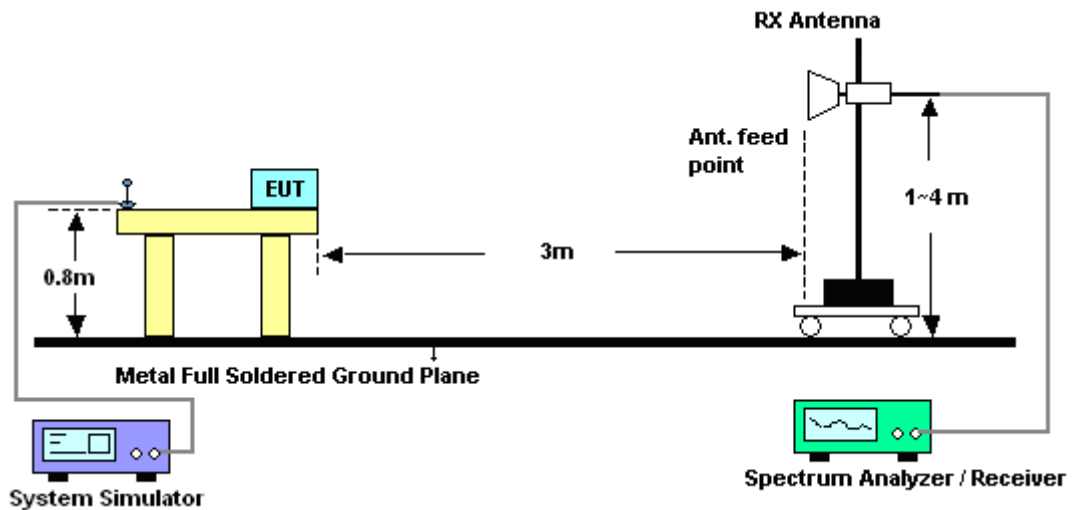

3.2.5. Test Result of Radiated Emission

Test Mode :	Mode 3	Temperature :	22~23°C
Test Engineer :	Steven Hao	Relative Humidity :	41~42%
Test Distance :	3m	Polarization :	Horizontal
Function Type :	CDMA2000 BC15 Idle + Bluetooth Idle + WLAN Idle + USB Cable (Data Link with PC) + GPS Rx		

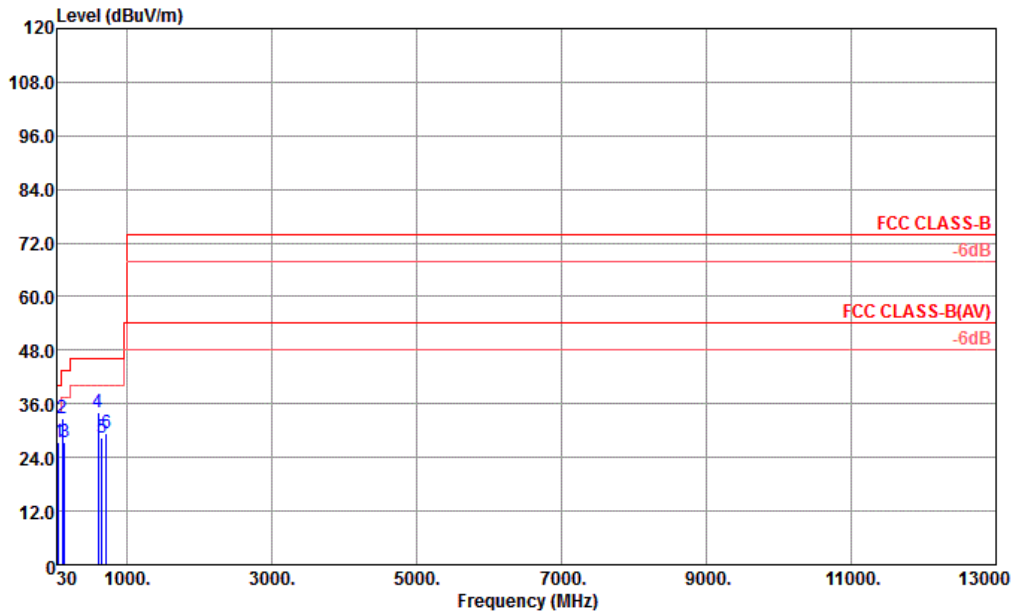

Site : 03CH01-KS
 Condition : FCC CLASS-B 3m LF_ANT-100803 HORIZONTAL
 Project : (FC) 311602
 Mode : Mode 3

	Freq	Level	Over Limit	Limit Line	ReadAntenna Level	Antenna Factor	Cable Loss	Preamp Factor	A/Pos	T/Pos	Remark
	MHz	dBuV/m	dB	dBuV/m	dBuV	dB/m	dB	dB	cm	deg	
1	59.10	27.54	-12.46	40.00	55.21	5.43	0.47	33.57	---	---	Peak
2	104.69	32.74	-10.76	43.50	54.62	11.14	0.58	33.60	111	26	Peak
3	139.61	27.28	-16.22	43.50	49.27	10.89	0.70	33.58	---	---	Peak
4	600.36	34.25	-11.75	46.00	47.21	18.59	1.39	32.94	---	---	Peak
5	649.83	28.36	-17.64	46.00	40.96	18.89	1.45	32.94	---	---	Peak
6	720.64	29.39	-16.61	46.00	41.16	19.53	1.53	32.83	---	---	Peak



Test Mode :	Mode 3	Temperature :	22~23°C
Test Engineer :	Steven Hao	Relative Humidity :	41~42%
Test Distance :	3m	Polarization :	Vertical
Function Type :	CDMA2000 BC15 Idle + Bluetooth Idle + WLAN Idle + USB Cable (Data Link with PC) + GPS Rx		

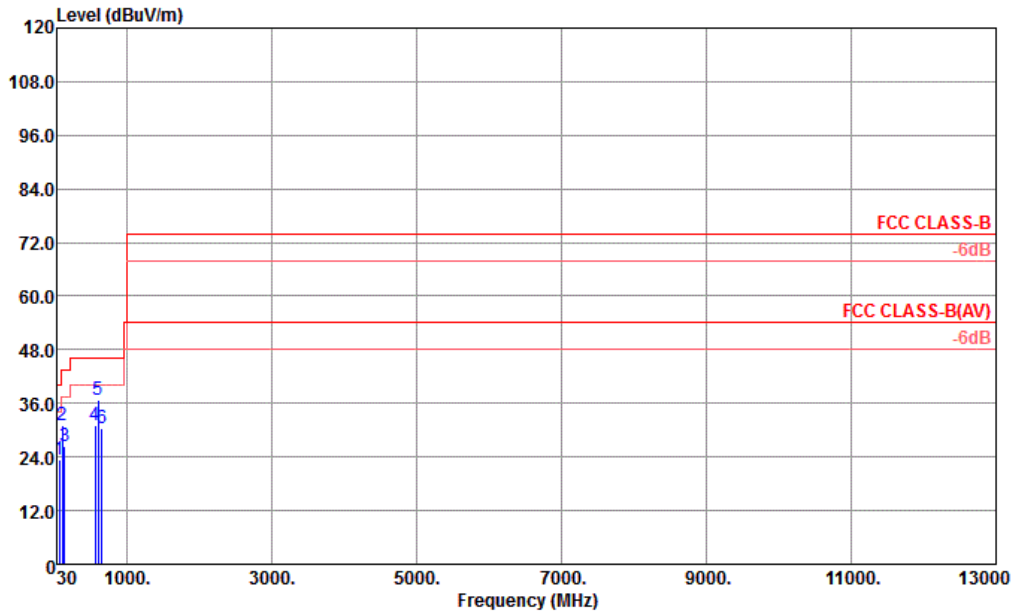

Site : 03CH01-KS
 Condition : FCC CLASS-B 3m LF_ANT-100803 VERTICAL
 Project : (FC) 311602
 Mode : Mode 3

	Freq	Level	Over Limit	Limit Line	ReadAntenna Level	Cable Factor	Preamp Loss	A/Pos	T/Pos	Remark	
	MHz	dBuV/m	dB	dBuV/m	dBuV	dB/m	dB	dB	cm	deg	
1	65.89	23.37	-16.63	40.00	51.25	5.21	0.49	33.58	---	---	Peak
2	105.66	31.20	-12.30	43.50	52.95	11.27	0.58	33.60	---	---	Peak
3	141.55	26.55	-16.95	43.50	48.70	10.73	0.70	33.58	---	---	Peak
4	564.47	31.02	-14.98	46.00	44.16	18.51	1.34	32.99	---	---	Peak
5	601.33	36.70	-9.30	46.00	49.66	18.59	1.39	32.94	100	246	Peak
6	649.83	30.54	-15.46	46.00	43.14	18.89	1.45	32.94	---	---	Peak

4. List of Measuring Equipment

Instrument	Manufacturer	Model No.	Serial No.	Characteristics	Calibration Date	Test Date	Due Date	Remark
EMI Receiver	R&S	ESC17	100768	9kHz~7GHz	Jun. 01, 2012	Jan. 21, 2013	May 31, 2013	Conduction (CO01-KS)
LISN	MessTec	AN3016	60103	9kHz~30MHz	Dec. 29, 2012	Jan. 21, 2013	Dec. 28, 2013	Conduction (CO01-KS)
LISN	MessTec	AN3016	60105	9kHz~30MHz	Dec. 29, 2012	Jan. 21, 2013	Dec. 28, 2013	Conduction (CO01-KS)
AC Power Source	Chroma	61602	ABP0000008 11	N/A	Nov. 15, 2012	Jan. 21, 2013	Nov. 14, 2013	Conduction (CO01-KS)
EMI Test Receiver	R&S	ESC1	100534	9kHz~3GHz	Nov. 08, 2012	Jan. 25, 2013	Nov. 07, 2013	Radiation (03CH01-KS)
Spectrum Analyzer	R&S	FSP30	100400	9kHz~30GHz	Jun. 01, 2012	Jan. 25, 2013	May 31, 2013	Radiation (03CH01-KS)
Bilog Antenna	SCHAFFNER	CBL6112D	23182	25MHz~2GHz	Dec. 07, 2012	Jan. 25, 2013	Dec. 06, 2013	Radiation (03CH01-KS)
Double Ridge Horn Antenna	EMCO	3117	00075959	1GHz~18GHz	Dec. 29, 2012	Jan. 25, 2013	Dec. 28, 2013	Radiation (03CH01-KS)
Amplifier	com-power	PA-103A	161069	1MHz~1GHz	Jun. 01, 2012	Jan. 25, 2013	May 31, 2013	Radiation (03CH01-KS)
Amplifier	Agilent	8449B	3008A02370	1GHz~26.5GHz	Dec. 29, 2012	Jan. 25, 2013	Dec. 28, 2013	Radiation (03CH01-KS)
System Simulator	R&S	CMU200	837587/066	2G Full-Band	Dec. 29, 2012	Jan. 21, 2013~ Jan. 25, 2013	Dec. 28, 2013	-
LTE Base Station	Anritsu	MT8820C	6201074414	N/A	Dec. 29, 2012	Jan. 21, 2013~ Jan. 25, 2013	Dec. 28, 2013	-
GPS Station	ADIVIC	MP9000	MP9000-111 046	N/A	N/A	Jan. 21, 2013~ Jan. 25, 2013	N/A	-

5. Uncertainty of Evaluation

Uncertainty of Conducted Emission Measurement (150 KHz ~ 30 MHz)

Measuring Uncertainty for a Level of Confidence of 95% (U = 2Uc(y))	2.26
---	------

Uncertainty of Radiated Emission Measurement (30 MHz ~ 1000 MHz)

Measuring Uncertainty for a Level of Confidence of 95% (U = 2Uc(y))	2.54
---	------

Uncertainty of Radiated Emission Measurement (1 GHz ~ 40 GHz)

Measuring Uncertainty for a Level of Confidence of 95% (U = 2Uc(y))	4.72
---	------



Appendix A. Photographs of EUT

Please refer to Sporton report number EP311602 as below.