

FCC RF Test Report

APPLICANT : Yulong Computer Telecommunication Scientific (Shenzhen) Co., Ltd.
EQUIPMENT : cdma2000/LTE dual-mode Mobile Phone
BRAND NAME : Coolpad
MODEL NAME : Coolpad 5860E
FCC ID : R38YL5860E
STANDARD : FCC 47 CFR Part 2, 22(H), 24(E), 27(L)
CLASSIFICATION : PCS Licensed Transmitter Held to Ear (PCE)
Tx/Rx FREQUENCY RANGE : CDMA2000 BC0 : 824.70 MHz ~ 848.31 MHz / 869.70 MHz ~ 893.31 MHz
CDMA2000 BC1 : 1851.25 MHz ~ 1908.75 MHz / 1931.25 ~ 1988.75 MHz
CDMA2000 BC15 : 1711.25 ~ 1753.75 MHz / 2111.25 ~ 2153.75 MHz
MAX. ERP/EIRP POWER : CDMA2000 BC0 : 0.1936 W
CDMA2000 BC1 : 0.2679 W
CDMA2000 BC15 : 0.6607 W

The product was received on Mar. 09, 2012 and completely tested on May 07, 2012. We, SPORTON INTERNATIONAL (KUNSHAN) INC., would like to declare that the tested sample has been evaluated in accordance with the procedures given in ANSI / TIA / EIA-603-C-2004 and shown compliance with the applicable technical standards.

The test results in this report apply exclusively to the tested model / sample. Without written approval of SPORTON INTERNATIONAL (KUNSHAN) INC., the test report shall not be reproduced except in full.

Reviewed by:



Jones Tsai / Manager



SPORTON INTERNATIONAL (KUNSHAN) INC.
No. 3-2, PingXiang Road, Kunshan, Jiangsu Province, P.R.C.



TABLE OF CONTENTS

REVISION HISTORY..... 3

SUMMARY OF TEST RESULT 4

1 GENERAL DESCRIPTION 5

 1.1 Applicant..... 5

 1.2 Manufacturer 5

 1.3 Feature of Equipment Under Test..... 5

 1.4 Emission Designator 6

 1.5 Testing Site 6

 1.6 Applied Standards 6

 1.7 Ancillary Equipment List..... 7

2 TEST CONFIGURATION OF EQUIPMENT UNDER TEST 8

 2.1 Test Mode..... 8

 2.2 Connection Diagram of Test System 10

3 TEST RESULT..... 11

 3.1 Conducted Output Power Measurement..... 11

 3.2 Effective Radiated Power and Effective Isotropic Radiated Power Measurement 13

 3.3 Occupied Bandwidth Measurement 19

 3.4 Band Edge Measurement..... 29

 3.5 Conducted Emission Measurement 36

 3.6 Field Strength of Spurious Radiation Measurement 45

 3.7 Frequency Stability Measurement..... 54

4 LIST OF MEASURING EQUIPMENTS 59

5 UNCERTAINTY OF EVALUATION 60

APPENDIX A. PHOTOGRAPHS OF EUT

APPENDIX B. SETUP PHOTOGRAPHS



REVISION HISTORY

REPORT NO.	VERSION	DESCRIPTION	ISSUED DATE
FG230902A	Rev. 01	Initial issue of report	May 14, 2012
FG230902A	Rev. 02	Update report for revising the model name	May 24, 2012



SUMMARY OF TEST RESULT

Report Section	FCC Rule	IC Rule	Description	Limit	Result	Remark
3.1	§2.1046	N/A	Conducted Output Power	N/A	PASS	-
3.2	§22.913(a)(2)	RSS-132(4.4) SRSP-503(5.1.3)	Effective Radiated Power	< 7 Watts	PASS	-
3.2	§24.232(c)	RSS-133 (6.4) SRSP-510(5.1.2)	Equivalent Isotropic Radiated Power	< 2 Watts	PASS	-
3.2	§27.50(d)(4)	RSS-139 (6.4) SRSP-513(5.1.2)	Equivalent Isotropic Radiated Power	< 1 Watts	PASS	-
3.2	§24.232(d) §27.50(d)(5)	N/A	Peak-to-Average Ratio	< 13 dB	PASS	-
3.3	§2.1049 §22.917(a) §24.238(a) §27.53(g)	N/A	Occupied Bandwidth	N/A	PASS	-
3.4	§2.1051 §22.917(a) §24.238(a) §27.53(g)	RSS-132 (4.5.1) RSS-133 (6.5.1) RSS-139 (6.5)	Band Edge Measurement	< 43+10log ₁₀ (P[Watts])	PASS	-
3.5	§2.1051 §22.917(a) §24.238(a) §27.53(g)	RSS-132 (4.5.1) RSS-133 (6.5.1) RSS-139 (6.5)	Conducted Emission	< 43+10log ₁₀ (P[Watts])	PASS	-
3.6	§2.1053 §22.917(a) §24.238(a) §27.53(g)	RSS-132 (4.5.1) RSS-133 (6.5.1) RSS-139 (6.5)	Field Strength of Spurious Radiation	< 43+10log ₁₀ (P[Watts])	PASS	Under limit 37.92 dB at 12118.75 MHz
3.7	§2.1055 §22.355 §24.235 §27.54	RSS-132 (4.3) RSS-133 (6.3) RSS-139 (6.3)	Frequency Stability for Temperature & Voltage	< 2.5 ppm	PASS	-



1 General Description

1.1 Applicant

Yulong Computer Telecommunication Scientific (Shenzhen) Co., Ltd.

Hi-Tech Industry Park(North), Nanshan District, Shenzhen City, Guangdong Province, P.R.C.

1.2 Manufacturer

Yulong Computer Telecommunication Scientific (Shenzhen) Co., Ltd.

Hi-Tech Industry Park(North), Nanshan District, Shenzhen City, Guangdong Province, P.R.C.

1.3 Feature of Equipment Under Test

Product Feature & Specification	
Equipment	cdma2000/LTE dual-mode Mobile Phone
Brand Name	Coolpad
Model Name	Coolpad 5860E
FCC ID	R38YL5860E
Tx Frequency	CDMA2000 BC0: 824.70 MHz ~ 848.31 MHz CDMA2000 BC1: 1851.25 MHz ~ 1908.75 MHz CDMA2000 BC15 : 1711.25 ~ 1753.75 MHz
Rx Frequency	CDMA2000 BC0: 869.70 MHz ~ 893.31 MHz CDMA2000 BC1: 1931.25 MHz ~ 1988.75 MHz CDMA2000 BC15 : 2111.25 ~ 2153.75 MHz
Maximum Output Power to Antenna	CDMA2000 BC0 : 23.40 dBm CDMA2000 BC1 : 23.85 dBm CDMA2000 BC15 : 23.99 dBm
Antenna Type	IFA + Parasitic Antenna
HW Version	P4
SW Version	CP5860E-user 2.3.7 GWK74 2.3.027.P3.120220.5860E release-keys
Type of Modulation	QPSK
EUT Stage	Identical Prototype

Remark: The above EUT's information was declared by manufacturer. Please refer to the specifications or user's manual for more detailed description.

1.4 Emission Designator

FCC Rule	System	Type of Modulation	Emission Designator	Maximum ERP/EIRP
Part 22	CDMA2000 BC0 1xRTT	QPSK	1M27F9W	0.1936 W
Part 24	CDMA2000 BC1 1xRTT	QPSK	1M27F9W	0.2679 W
Part 27	CDMA2000 BC15 1xRTT	QPSK	1M27F9W	0.6607 W

1.5 Testing Site

Test Site	SPORTON INTERNATIONAL (KUNSHAN) INC.		
Test Site Location	No. 3-2, PingXiang Road, Kunshan, Jiangsu Province, P.R.C. TEL: +86-0512-5790-0158 FAX: +86-0512-5790-0958		
Test Site No.	Sporton Site No.		FCC/IC Registration No.
	TH01-KS	03CH01-KS	149928/4086E-1

1.6 Applied Standards

According to the specifications of the manufacturer, the EUT must comply with the requirements of the following standards:

- ♦ Preliminary Guidance for Receiving Applications for Certification of 3G Device. May 9, 2006.
- ♦ 47 CFR Part 2, 22(H), 24(E), 27(L)
- ♦ ANSI / TIA / EIA-603-C-2004
- ♦ FCC KDB 971168 D01 Power Meas. License Digital Systems v01
- ♦ IC RSS-132 Issue 2
- ♦ IC RSS-133 Issue 5
- ♦ IC RSS-139 Issue 2

Remark:

1. All test items were verified and recorded according to the standards and without any deviation during the test.
2. This EUT has also been tested and complied with the requirements of FCC Part 15, Subpart B, recorded in a separate test report.



1.7 Ancillary Equipment List

Item	Equipment	Trade Name	Model No.	FCC ID	Data Cable	Power Cord
1.	System Simulator	R&S	CMU200	N/A	N/A	Unshielded, 1.8 m
2.	DC Power Supply	TOPWARD	GPS-3030D	N/A	N/A	Unshielded, 1.8 m

2 Test Configuration of Equipment Under Test

2.1 Test Mode

During all testing, EUT is in link mode with base station emulator at maximum power level. The spurious emission measurements were carried out in semi-anechoic chamber with 3-meter test range, and EUT is rotated on three test planes to find out the worst emission.

Frequency range investigated for radiated emission is as follows:

1. 30 MHz to 9000 MHz for CDMA2000 BC0.
2. 30 MHz to 19000 MHz for CDMA2000 BC1.
3. 30 MHz to 18000 MHz for CDMA2000 BC15.

Test Modes		
Band	Radiated TCs	Conducted TCs
CDMA2000 BC0	■ 1xRTT Link Mode	■ 1xRTT Link Mode
CDMA2000 BC1	■ 1xRTT Link Mode	■ 1xRTT Link Mode
CDMA2000 BC15	■ 1xRTT Link Mode	■ 1xRTT Link Mode

Note:

1. The maximum RF output power levels are 1xRTT RC3+SO55 mode for CDMA2000 BC0, 1xRTT RC3+SO55 mode for CDMA2000 BC1, and 1xRTT RC3+SO32 (+ F-SCH) mode for CDMA2000 BC15 on QPSK link; only these modes were used for all tests.
2. Because there are individual antennas for each CDMA2000, WLAN, and Bluetooth, the co-location test modes are not required.
3. Because there are individual antennas for each WWAN, and the Bluetooth and WLAN share a common antenna but can't transmit simultaneously, the co-location test modes are not required.



The conducted power tables are as follows:

Conducted Power (*Unit: dBm)									
Band	CDMA2000 BC0			CDMA2000 BC1			CDMA2000 BC15		
Channel	1013	384	777	25	600	1175	25	425	875
Frequency	824.7	836.52	848.31	1851.25	1880	1908.75	1711.25	1731.25	1753.75
1xRTT RC1+SO55	23.39	23.30	23.33	23.77	23.64	23.44	23.93	23.91	23.88
1xRTT RC3+SO55	23.40	23.34	23.35	23.85	23.70	23.55	23.97	23.93	23.89
1xRTT RC3+SO32(+ F-SCH)	23.37	23.29	23.28	23.80	23.66	23.46	23.99	23.91	23.87
1xRTT RC3+SO32(+SCH)	22.92	22.78	22.73	23.31	23.12	22.95	23.43	23.41	23.40
1xEVDO RTAP 153.6	23.37	23.26	23.28	23.81	23.68	23.49	23.92	23.88	23.86
1xEVDO RETAP 4096	23.34	23.25	23.33	23.83	23.70	23.51	23.92	23.90	23.82

2.2 Connection Diagram of Test System

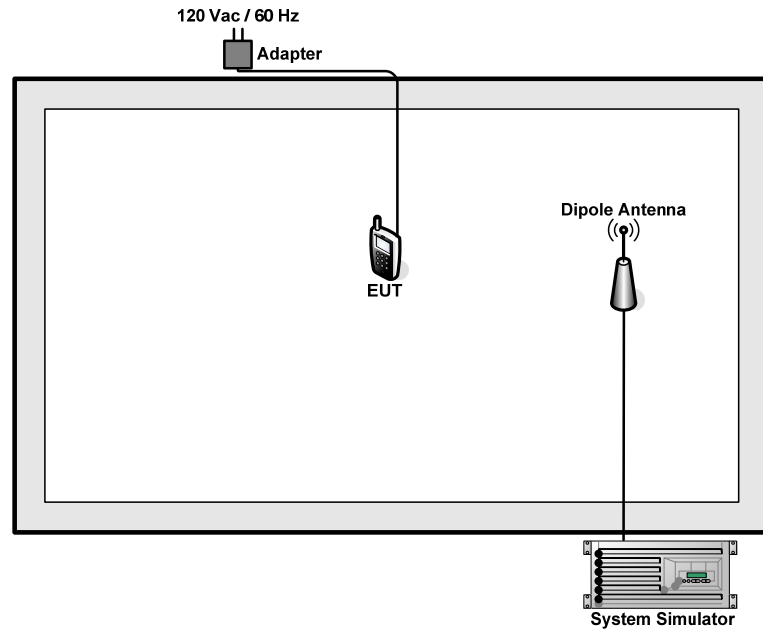

3 Test Result

3.1 Conducted Output Power Measurement

3.1.1 Description of the Conducted Output Power Measurement

A base station simulator was used to establish communication with the EUT. Its parameters were set to transmit the maximum power on the EUT. The measured power in the radio frequency on the transmitter output terminals shall be reported.

3.1.2 Measuring Instruments

See list of measuring instruments of this test report.

3.1.3 Test Procedures

1. The transmitter output port was connected to base station.
2. Set EUT at maximum power through base station.
3. Select lowest, middle, and highest channels for each band and different modulation.

3.1.4 Test Setup

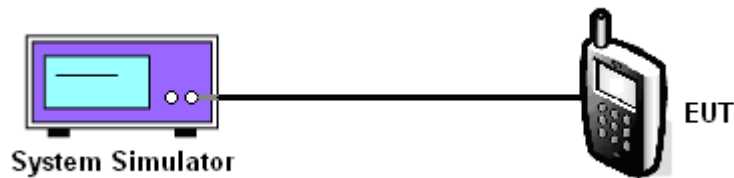



3.1.5 Test Result of Conducted Output Power

CDMA2000 BC0			
Test Mode	CDMA 2000 1xRTT		
Test Status	RC3+SO55		
Channel	1013 (Low)	384 (Mid)	777 (High)
Frequency (MHz)	824.70	836.52	848.31
Conducted Power (dBm)	23.40	23.34	23.35
Conducted Power (Watts)	0.22	0.22	0.22

CDMA2000 BC1			
Test Mode	CDMA 2000 1xRTT		
Test Status	RC3+SO55		
Channel	25 (Low)	600 (Mid)	1175 (High)
Frequency (MHz)	1851.25	1880.00	1908.75
Conducted Power (dBm)	23.85	23.70	23.55
Conducted Power (Watts)	0.24	0.23	0.23

CDMA2000 BC15			
Test Mode	CDMA 2000 1xRTT		
Test Status	RC3+SO32		
Channel	25 (Low)	425 (Mid)	875 (High)
Frequency (MHz)	1711.25	1731.25	1753.75
Conducted Power (dBm)	23.99	23.91	23.87
Conducted Power (Watts)	0.25	0.25	0.24

3.2 Effective Radiated Power and Effective Isotropic Radiated Power Measurement

3.2.1 Description of the ERP/EIRP Measurement

The substitution method, in ANSI / TIA / EIA-603-C-2004, was used for ERP/EIRP measurement, and the spectrum analyzer configuration follows KDB 971168 D01 Power Meas. License Digital Systems v01. The ERP of mobile transmitters must not exceed 7 Watts and the EIRP of mobile transmitters are limited to 2 Watts.

3.2.2 Measuring Instruments

See list of measuring instruments of this test report.

3.2.3 Test Procedures

1. The EUT was placed on a non-conductive rotating platform with 0.8 meter height in a semi-anechoic chamber. The radiated emission at the fundamental frequency was measured at 3 m with a test antenna and a spectrum analyzer with RBW= 30kHz,VBW= 100kHz, and RMS detector settings per section 4.0 of KDB 971168 D01.
2. During the measurement, the EUT was enforced in maximum power and linked with a base station. The highest emission was recorded from analyzer power level (LVL) from the 360 degrees rotation of the turntable and the test antenna raised and lowered over a range from 1 to 4 meters in both horizontally and vertically polarized orientations.
3. Effective Isotropic Radiated Power (EIRP) was measured by substitution method according to TIA/EIA-603-C. The EUT was replaced by dipole antenna (substitution antenna) at same location, and then a known power from S.G. was applied into the dipole antenna through a Tx cable, and then recorded the maximum Analyzer reading through raised and lowered the test antenna. The correction factor (in dB) = S.G. - Tx Cable loss + Substitution antenna gain - Analyzer reading. Then the EUT's EIRP was calculated with the correction factor, $EIRP = LVL + \text{Correction factor}$ and $ERP = EIRP - 2.15$.

3.2.4 Test Setup

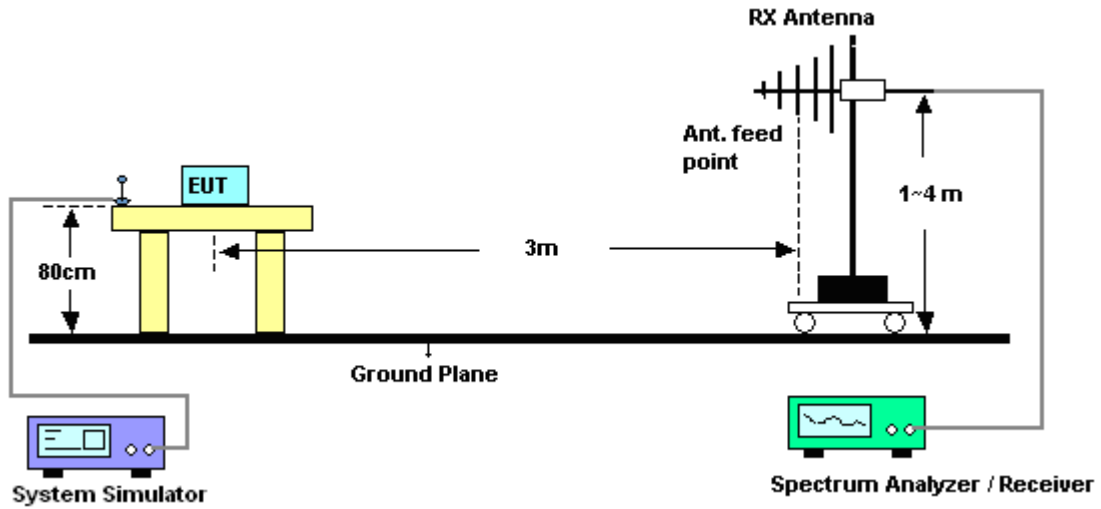

3.2.5 Test Result of ERP

CDMA2000 BC0 1xRTT_RC3+SO55 Radiated Power ERP				
Horizontal Polarization				
Frequency (MHz)	LVL (dBm)	Correction Factor (dB)	ERP (dBm)	ERP (W)
824.70	-3.01	28.03	22.87	0.1936
836.52	-2.61	27.39	22.63	0.1832
848.31	-4.40	26.75	20.2	0.1047
Vertical Polarization				
Frequency (MHz)	LVL (dBm)	Correction Factor (dB)	ERP (dBm)	ERP (W)
824.70	-12.59	31.32	16.58	0.0455
836.52	-13.42	31.01	15.44	0.0350
848.31	-14.64	31.27	14.48	0.0281

* ERP = LVL (dBm) + Correction Factor (dB) – 2.15



3.2.6 Test Result of EIRP

CDMA2000 BC1 1xRTT_RC3+SO55 Radiated Power EIRP				
Horizontal Polarization				
Frequency (MHz)	LVL (dBm)	Correction Factor (dB)	EIRP (dBm)	EIRP (W)
1851.25	-11.21	35.49	24.28	0.2679
1880.00	-12.81	35.33	22.52	0.1786
1908.75	-12.18	34.24	22.06	0.1607
Vertical Polarization				
Frequency (MHz)	LVL (dBm)	Correction Factor (dB)	EIRP (dBm)	EIRP (W)
1851.25	-22.21	40.08	17.87	0.0612
1880.00	-22.34	41.47	19.13	0.0818
1908.75	-21.58	41.22	19.64	0.0920

* EIRP = LVL (dBm) + Correction Factor (dB)

CDMA2000 BC151xRTT_RC3+SO32 Radiated Power EIRP				
Horizontal Polarization				
Frequency (MHz)	LVL (dBm)	Correction Factor (dB)	EIRP (dBm)	EIRP (W)
1711.25	-7.29	35.49	28.20	0.6607
1731.25	-8.67	35.33	26.66	0.4634
1753.75	-9.13	34.24	25.11	0.3243
Vertical Polarization				
Frequency (MHz)	LVL (dBm)	Correction Factor (dB)	EIRP (dBm)	EIRP (W)
1711.25	-13.70	40.08	26.38	0.4345
1731.25	-15.45	41.47	26.02	0.3999
1753.75	-15.71	41.22	25.51	0.3556

* EIRP = LVL (dBm) + Correction Factor (dB)



3.2.7 Peak to Average Power Ratio

CDMA2000 BC1 C.C.D.F.

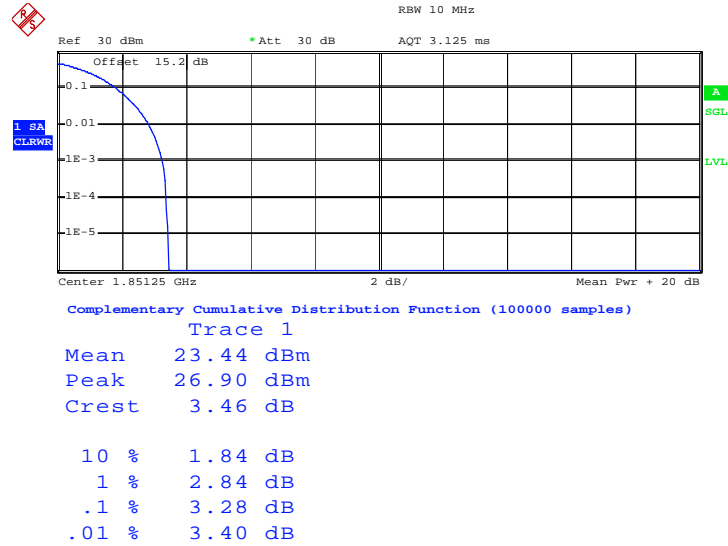

Date: 30.APR.2012 19:39:02

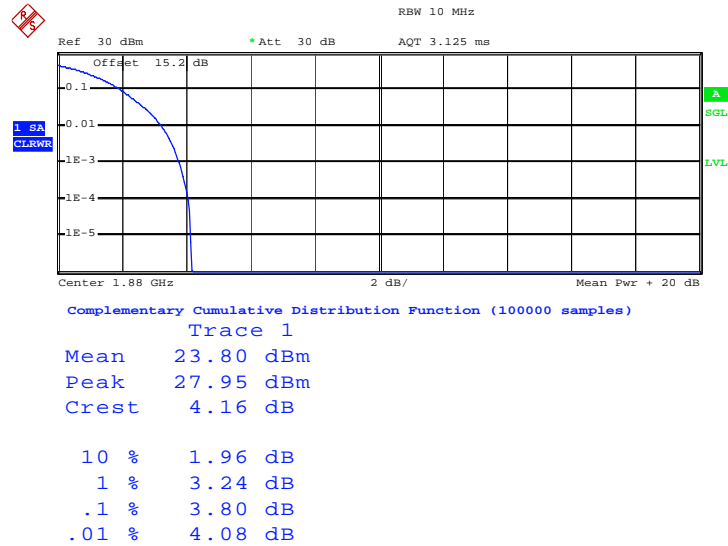

Date: 30.APR.2012 19:37:57

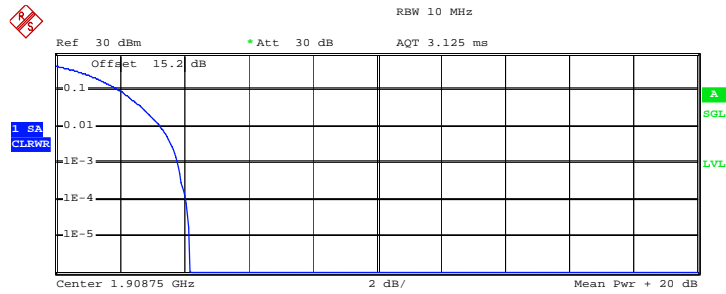

Complementary Cumulative Distribution Function (100000 samples)

Trace 1

Mean 23.35 dBm
 Peak 27.53 dBm
 Crest 4.18 dB

10 % 2.00 dB
 1 % 3.28 dB
 .1 % 3.80 dB
 .01 % 4.08 dB

Date: 30.APR.2012 19:37:07

CDMA2000 BC15 C.C.D.F.

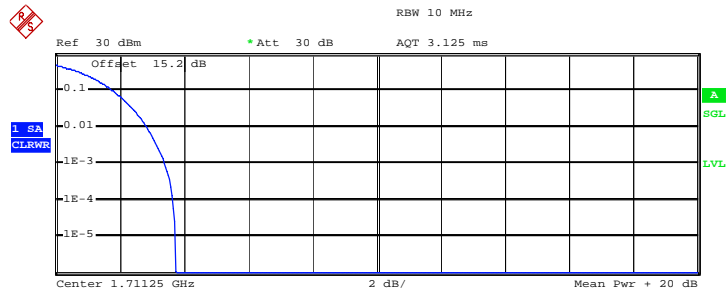

Complementary Cumulative Distribution Function (100000 samples)

Trace 1

Mean 23.85 dBm
 Peak 27.60 dBm
 Crest 3.75 dB

10 % 1.80 dB
 1 % 2.84 dB
 .1 % 3.40 dB
 .01 % 3.64 dB

Date: 30.APR.2012 20:43:47

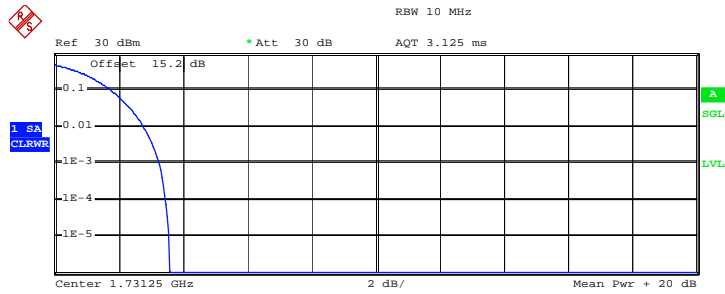

Complementary Cumulative Distribution Function (100000 samples)

Trace 1

Mean 23.60 dBm
 Peak 27.18 dBm
 Crest 3.58 dB

10 % 1.76 dB
 1 % 2.76 dB
 .1 % 3.28 dB
 .01 % 3.48 dB

Date: 30.APR.2012 20:42:52

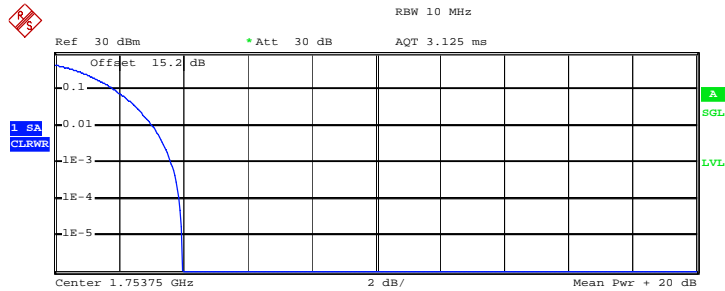

Complementary Cumulative Distribution Function (100000 samples)

Trace 1

Mean 23.63 dBm
 Peak 27.60 dBm
 Crest 3.97 dB

10 % 1.88 dB
 1 % 3.08 dB
 .1 % 3.64 dB
 .01 % 3.88 dB

Date: 30.APR.2012 20:41:17

3.3 Occupied Bandwidth Measurement

3.3.1 Description of Occupied Bandwidth Measurement

The emission bandwidth is defined as the width of the signal between two points, located at the 2 sides of the carrier frequency, outside of which all emissions are attenuated at least 26 dB below the transmitter power.

3.3.2 Measuring Instruments

See list of measuring instruments of this test report.

3.3.3 Test Procedures

1. The EUT was connected to Spectrum Analyzer and Base Station via power divider.
2. The 99% and 26 dB occupied bandwidth (BW) of the middle channel for the highest RF powers were measured.

3.3.4 Test Setup

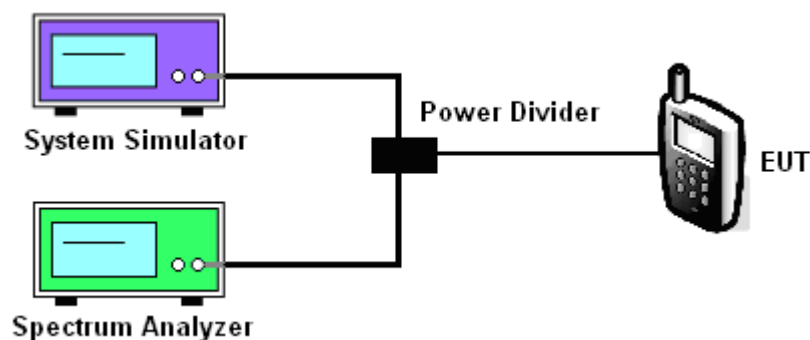



3.3.5 Test Result (Plots) of Occupied Bandwidth

Band :	CDMA2000 BC0	Power Stage :	High
Test Mode :	1xRTT_RC3+SO55		

99% Occupied Bandwidth Plot on Channel 1013

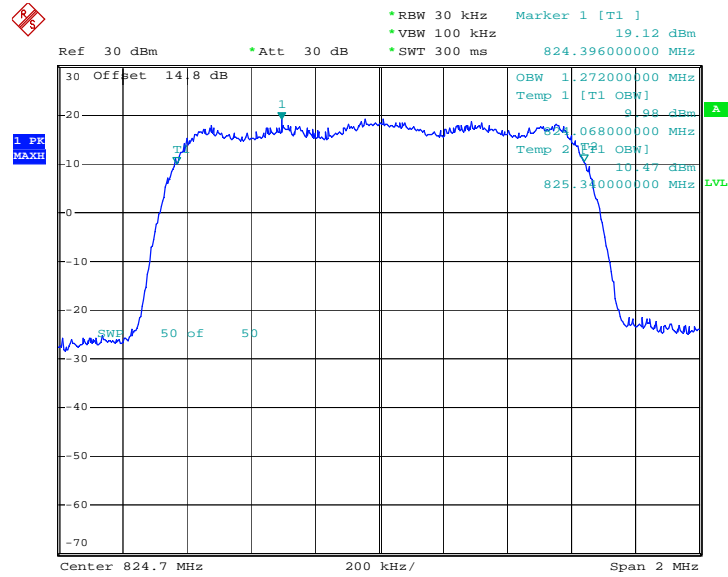

Date: 30.APR.2012 18:28:06

26dB Bandwidth Plot on Channel 1013

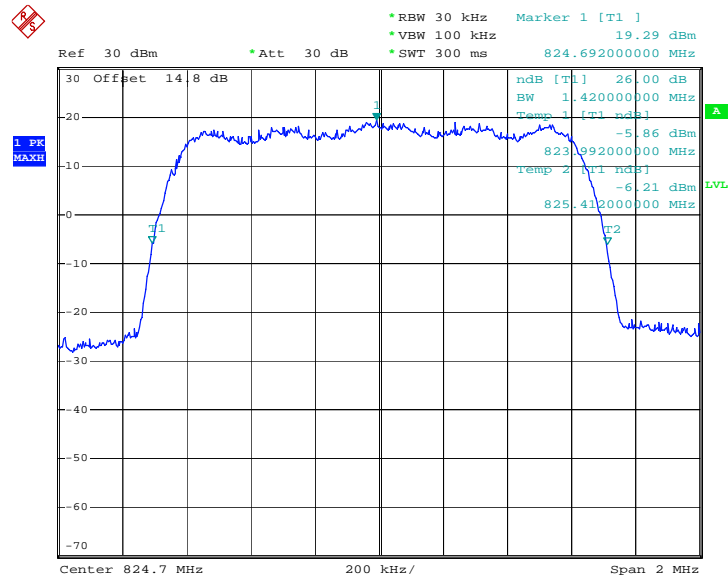

Date: 30.APR.2012 18:05:04



99% Occupied Bandwidth Plot on Channel 384

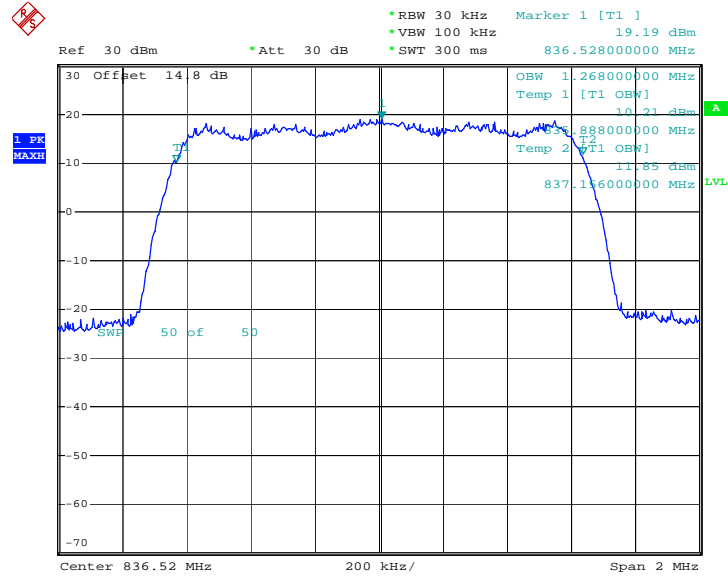

Date: 30.APR.2012 18:26:44

26dB Bandwidth Plot on Channel 384

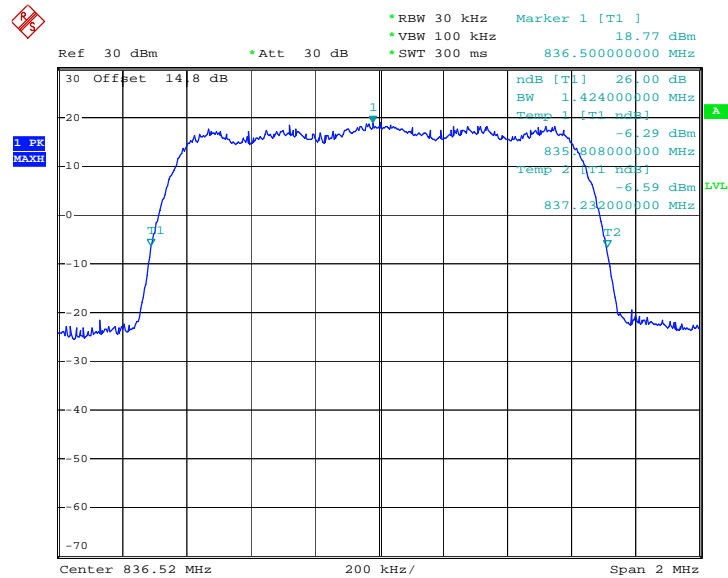

Date: 30.APR.2012 18:03:13



99% Occupied Bandwidth Plot on Channel 777

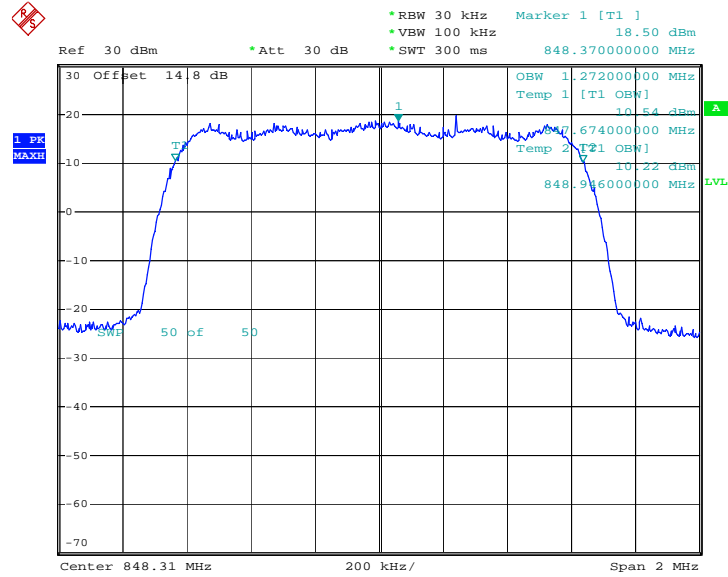

Date: 30.APR.2012 18:27:20

26dB Bandwidth Plot on Channel 777

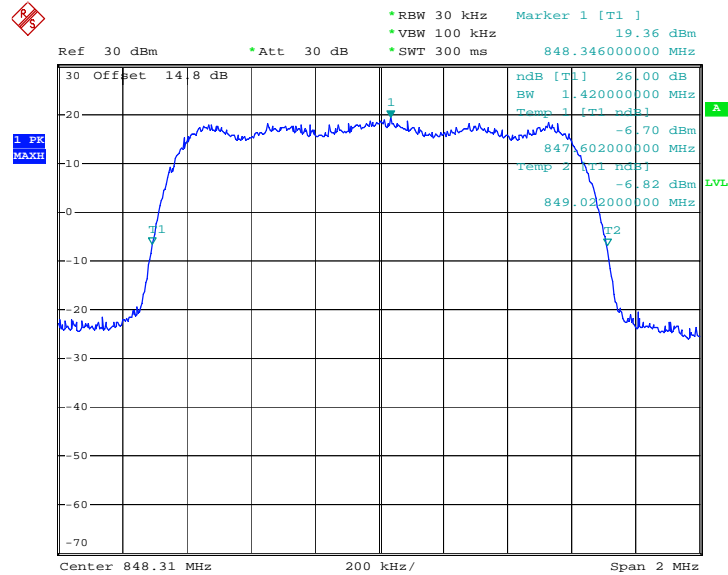

Date: 30.APR.2012 18:04:05



Band :	CDMA2000 BC1	Power Stage :	High
Test Mode :	1xRTT_RC3+SO55		

99% Occupied Bandwidth Plot on Channel 25

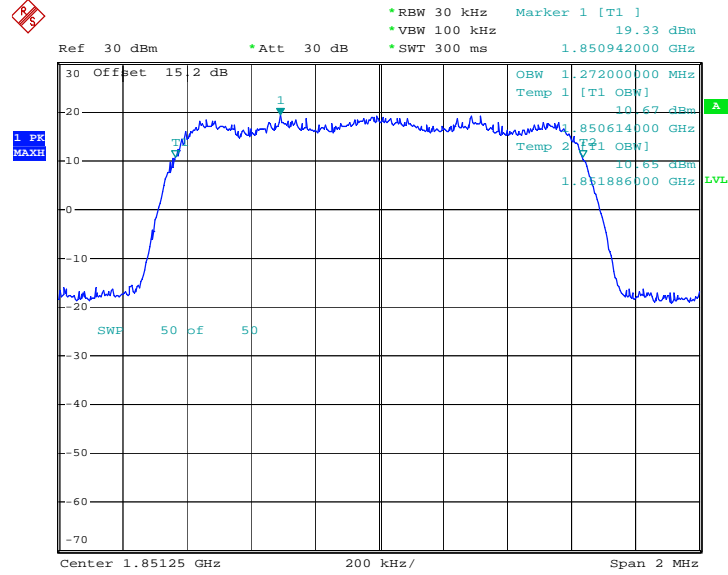

Date: 30.APR.2012 19:34:18

26dB Bandwidth Plot on Channel 25

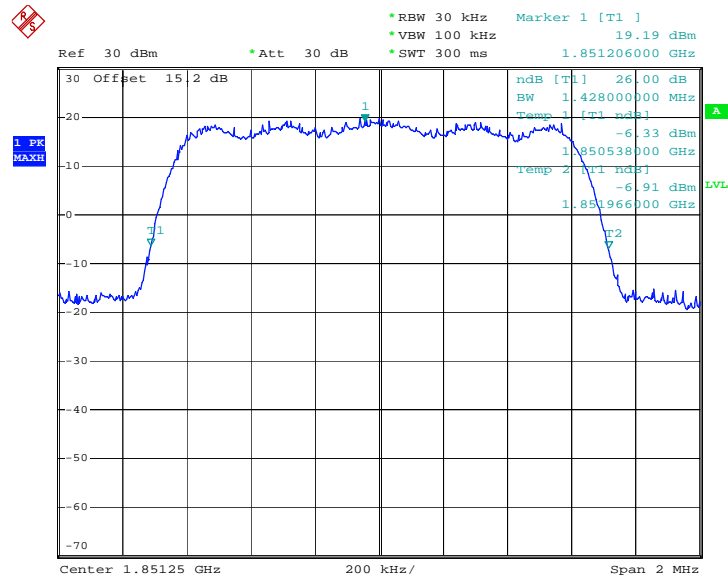

Date: 30.APR.2012 19:27:29



99% Occupied Bandwidth Plot on Channel 600

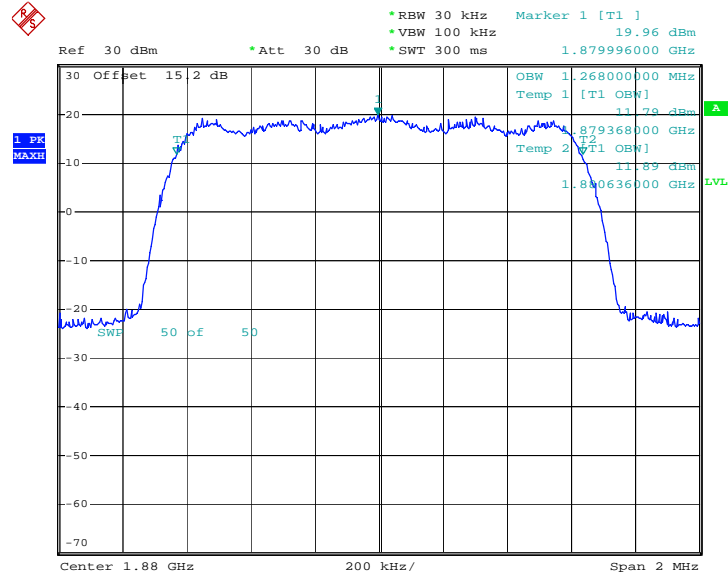

Date: 30.APR.2012 19:35:16

26dB Bandwidth Plot on Channel 600

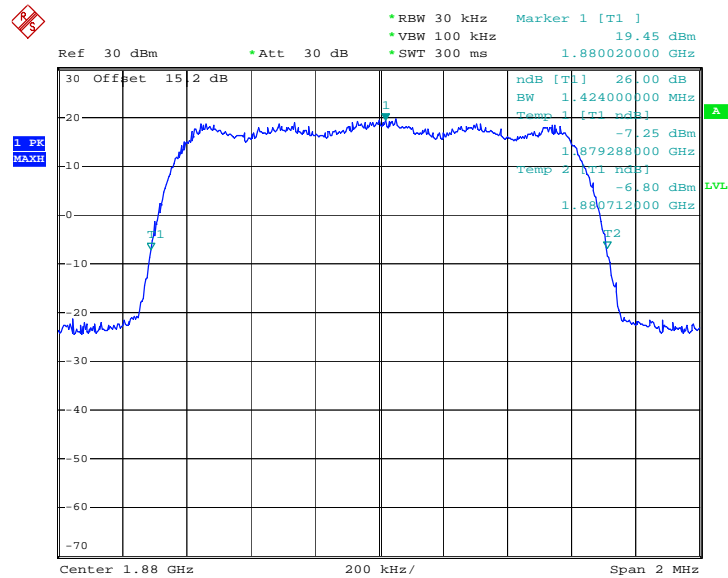

Date: 30.APR.2012 19:28:09



99% Occupied Bandwidth Plot on Channel 1175

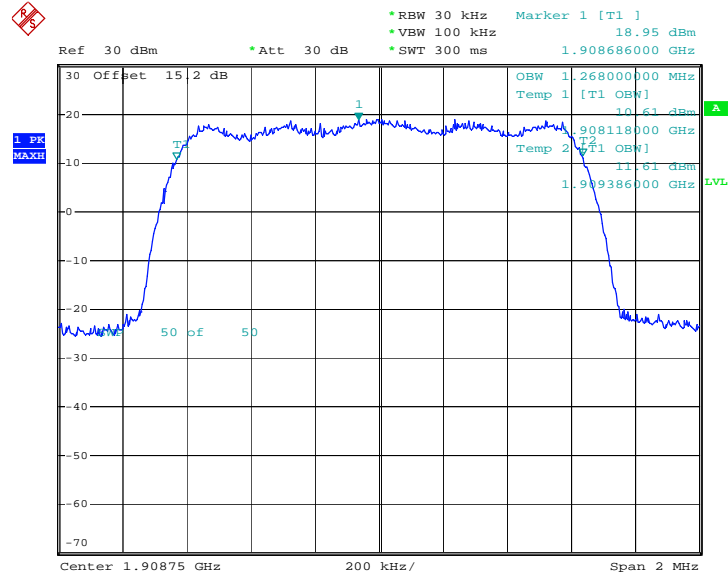

Date: 30.APR.2012 19:36:01

26dB Bandwidth Plot on Channel 1175

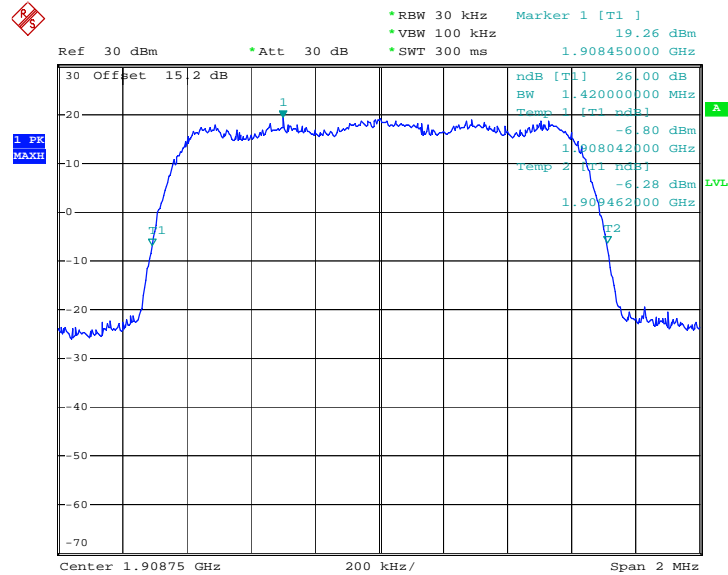

Date: 30.APR.2012 19:28:59



Band :	CDMA2000 BC15	Power Stage :	High
Test Mode :	1xRTT_RC3+SO32		

99% Occupied Bandwidth Plot on Channel 25

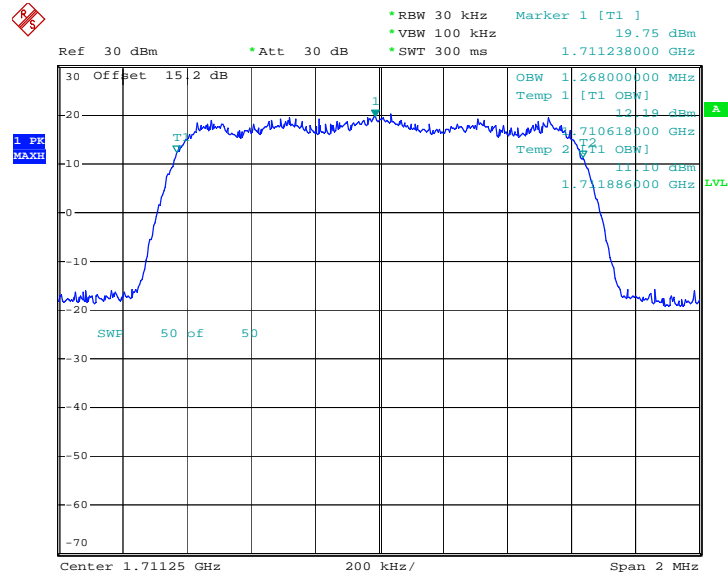

Date: 30.APR.2012 20:37:58

26dB Bandwidth Plot on Channel 25

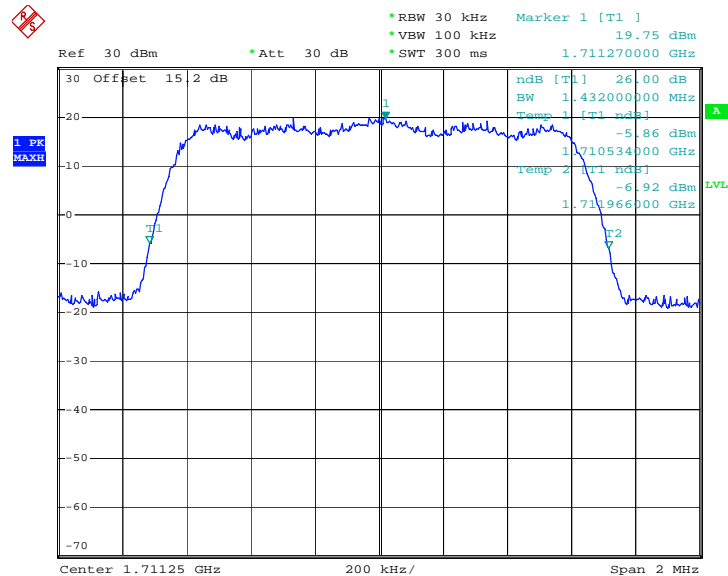

Date: 30.APR.2012 20:34:35



99% Occupied Bandwidth Plot on Channel 425

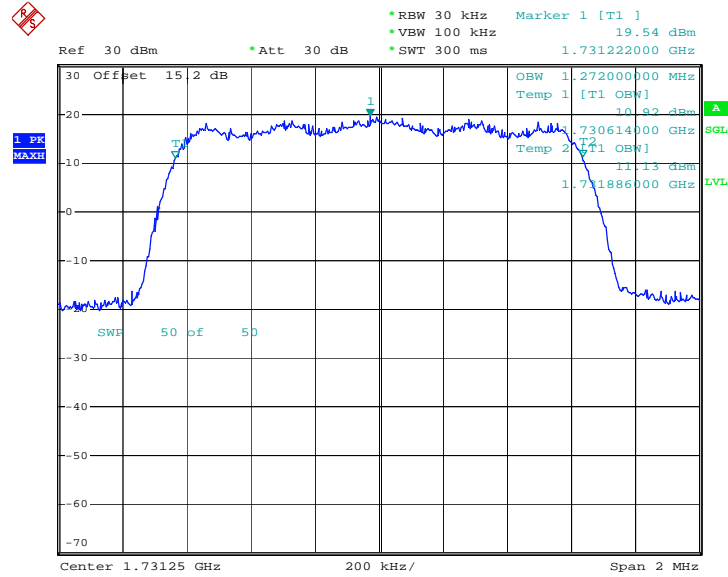

Date: 7.MAY.2012 20:58:45

26dB Bandwidth Plot on Channel 425

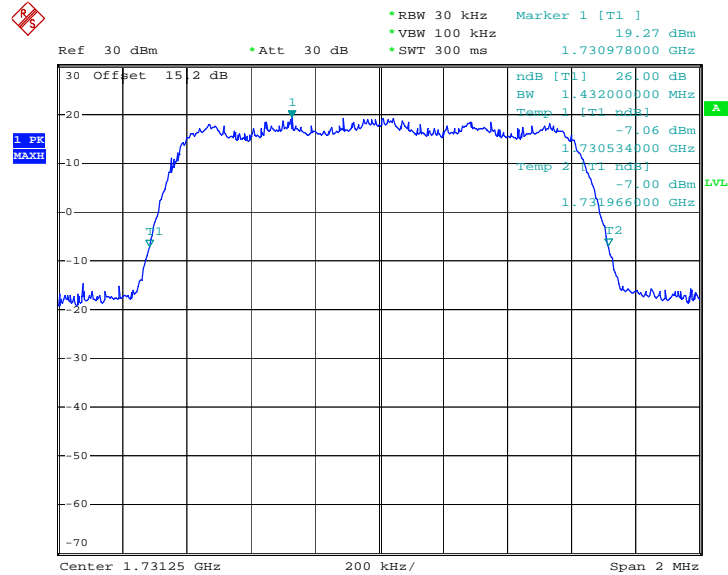

Date: 30.APR.2012 20:35:10



99% Occupied Bandwidth Plot on Channel 875

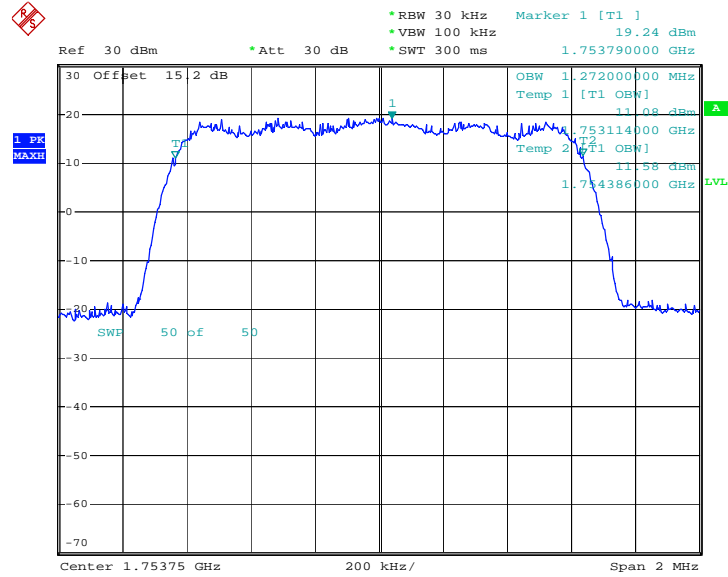

Date: 30.APR.2012 20:40:38

26dB Bandwidth Plot on Channel 875

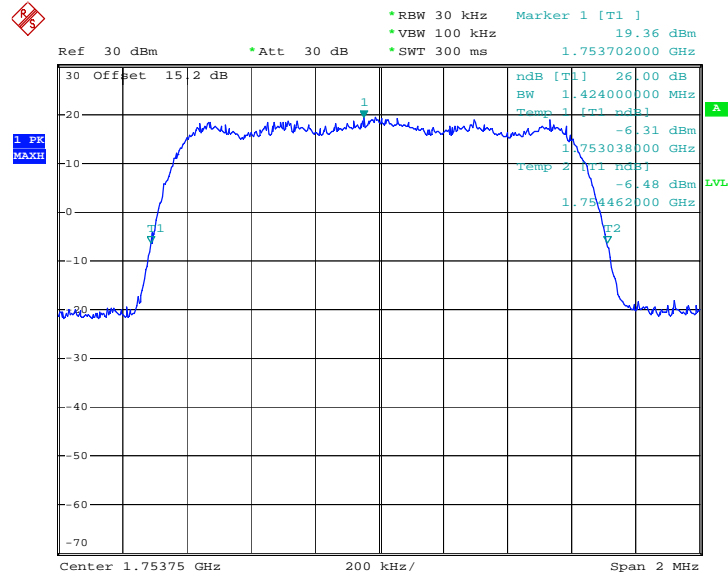

Date: 30.APR.2012 20:36:03

3.4 Band Edge Measurement

3.4.1 Description of Band Edge Measurement

The power of any emission outside of the authorized operating frequency ranges must be lower than the transmitter power (P) by a factor of at least $43 + 10 \log (P)$ dB.

3.4.2 Measuring Instruments

See list of measuring instruments of this test report.

3.4.3 Test Procedures

1. The EUT was connected to Spectrum Analyzer and Base Station via power divider.
2. The band edges of low and high channels for the highest RF powers were measured. Setting RBW as roughly $BW/100$.
3. The RBW was replaced by 10 kHz, slightly smaller than the value in (2), due to the spectrum analyzer limitation to set the exact value. A worst case correction factor of $10 \cdot \log (1\% \text{ emission-BW/measurement RBW})$ was compensated.

3.4.4 Test Setup

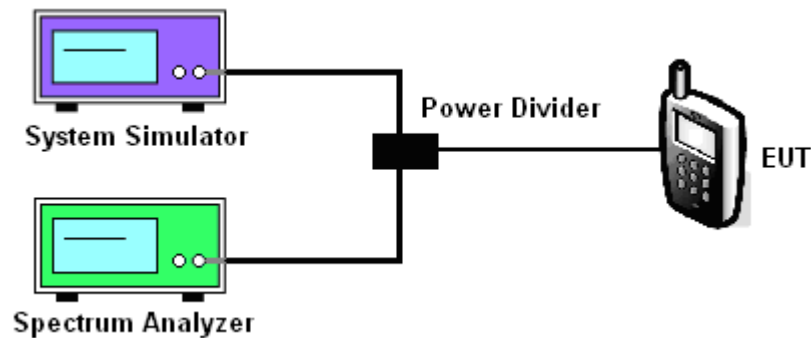

3.4.5 Test Result (Plots) of Conducted Band Edge

Band :	CDMA2000 BC0	Power Stage :	High
Test Mode :	1xRTT_RC3+SO55	Maximum 26dB Bandwidth:	1.424MHz
Correction Factor:	1.54dB	Measurement Value:	-21.89dBm
Band Edge:	-20.35dBm		

Lower Band Edge Plot on Channel 1013

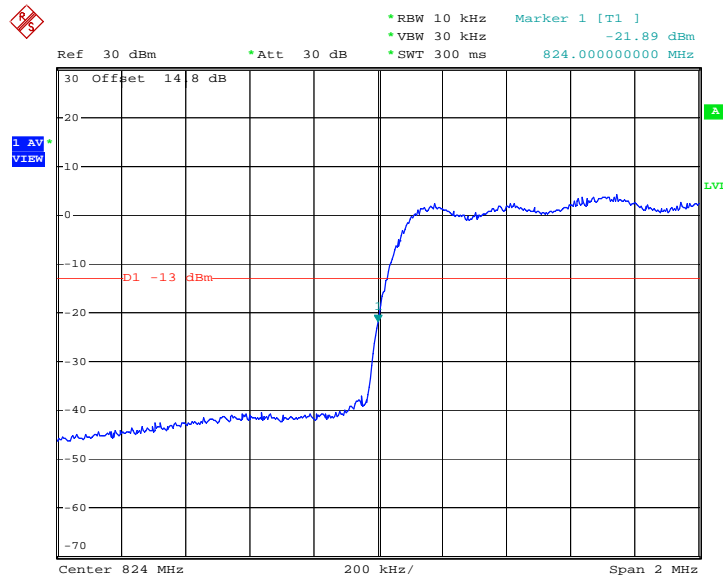

Date: 7.MAY.2012 11:05:42

1. Correction Factor(dB)= 10log(1% Emission BW/RBW)
2. Band Edge= Measurement Value + Correction Factor(dB)



Band :	CDMA2000 BC0	Power Stage :	High
Test Mode :	1xRTT_RC3+SO55	Maximum 26dB Bandwidth:	1.424MHz
Correction Factor:	1.54dB	Measurement Value:	-16.64dBm
Band Edge:	-15.10dBm		

Higher Band Edge Plot on Channel 777

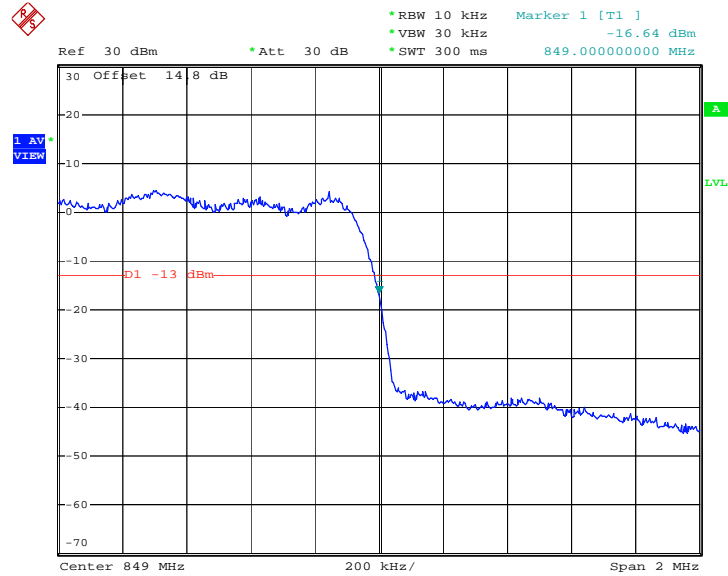

Date: 7.MAY.2012 11:07:30

1. Correction Factor(dB)= 10log(1% Emission BW/RBW)
2. Band Edge= Measurement Value + Correction Factor(dB)



Band :	CDMA2000 BC1	Power Stage :	High
Test Mode :	1xRTT_RC3+SO55	Maximum 26dB Bandwidth:	1.428MHz
Correction Factor:	1.55dB	Measurement Value:	-30.98dBm
Band Edge:	-29.43dBm		

Lower Band Edge Plot on Channel 25

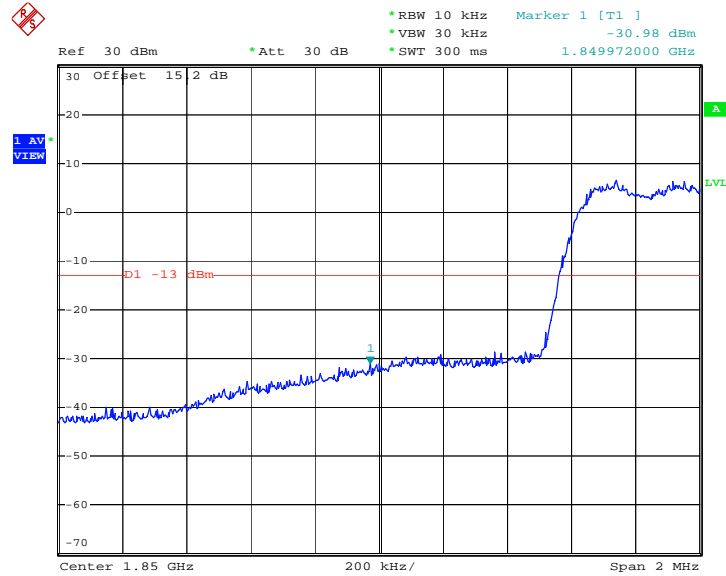

Date: 30.APR.2012 20:08:47

1. Correction Factor(dB)= $10\log(1\% \text{ Emission BW/RBW})$
2. Band Edge= Measurement Value + Correction Factor(dB)



Band :	CDMA2000 BC1	Power Stage :	High
Test Mode :	1xRTT_RC3+SO55	Maximum 26dB Bandwidth:	1.428MHz
Correction Factor:	1.55dB	Measurement Value:	-35.15dBm
Band Edge:	-33.60dBm		

Higher Band Edge Plot on Channel 1175

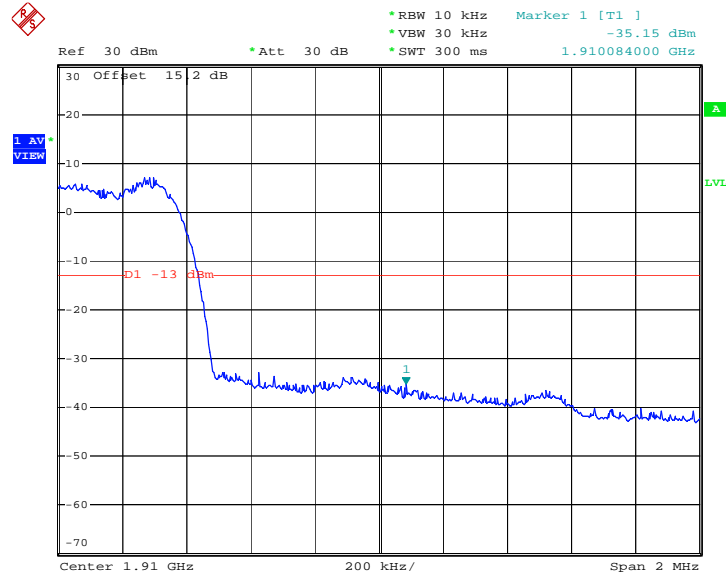

Date: 30.APR.2012 19:01:44

1. Correction Factor(dB)= $10\log(1\% \text{ Emission BW/RBW})$
2. Band Edge= Measurement Value + Correction Factor(dB)



Band :	CDMA2000 BC15	Power Stage :	High
Test Mode :	1xRTT_RC3+SO32	Maximum 26dB Bandwidth:	1.432MHz
Correction Factor:	1.56dB	Measurement Value:	-24.83dBm
Band Edge:	-23.27dBm		

Lower Band Edge Plot on Channel 25

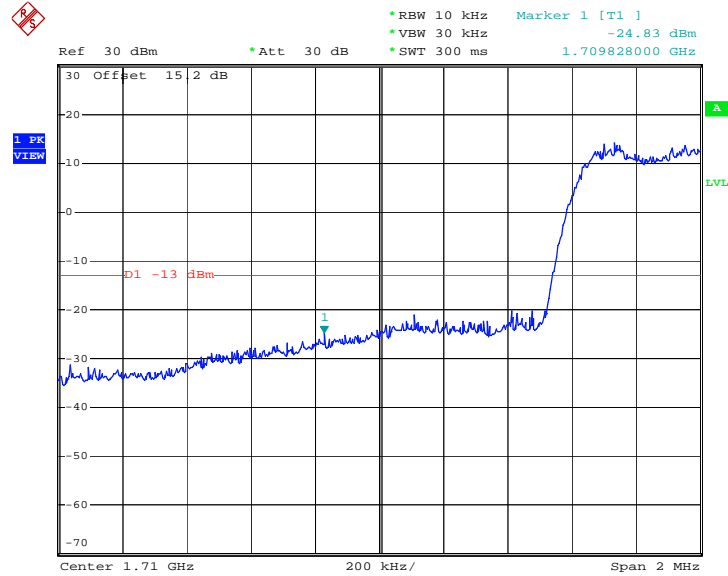

Date: 30.APR.2012 21:26:53

1. Correction Factor(dB)= $10\log(1\% \text{ Emission BW/RBW})$
2. Band Edge= Measurement Value + Correction Factor(dB)



Band :	CDMA2000 BC15	Power Stage :	High
Test Mode :	1xRTT_RC3+SO32	Maximum 26dB Bandwidth:	1.432MHz
Correction Factor:	1.56dB	Measurement Value:	-27.40dBm
Band Edge:	-25.84dBm		

Higher Band Edge Plot on Channel 875

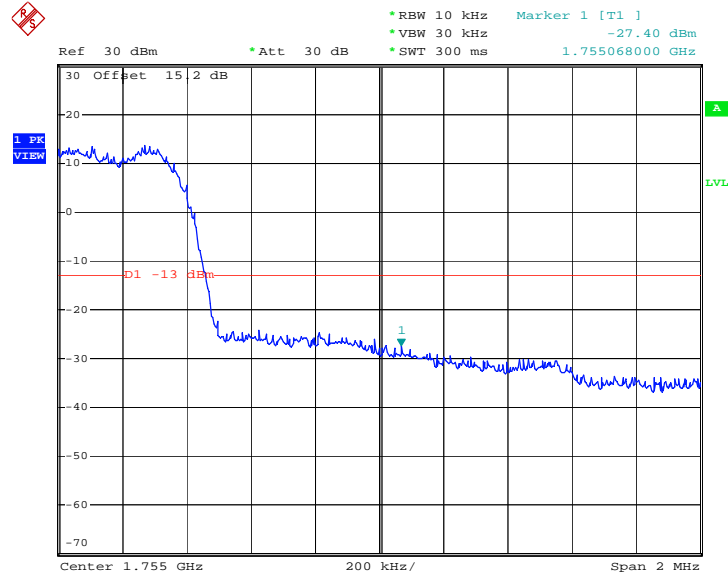

Date: 30.APR.2012 21:30:13

1. Correction Factor(dB)= $10\log(1\% \text{ Emission BW/RBW})$
2. Band Edge= Measurement Value + Correction Factor(dB)

3.5 Conducted Emission Measurement

3.5.1 Description of Conducted Emission Measurement

The power of any emission outside of the authorized operating frequency ranges must be lower than the transmitter power (P) by a factor of at least $43 + 10 \log (P)$ dB.

It is measured by means of a calibrated spectrum analyzer and scanned from 30 MHz up to a frequency including its 10th harmonic.

3.5.2 Measuring Instruments

See list of measuring instruments of this test report.

3.5.3 Test Procedures

1. The EUT was connected to spectrum analyzer and base station via power divider.
2. The middle channel for the highest RF power within the transmitting frequency was measured.
3. The conducted spurious emission for the whole frequency range was taken.

3.5.4 Test Setup

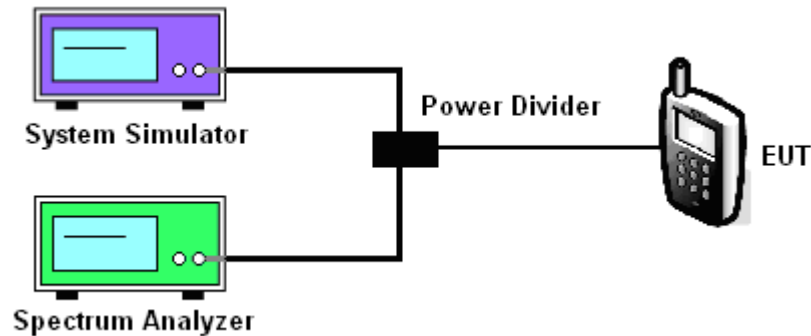



3.5.5 Test Result (Plots) of Conducted Emission

Band :	CDMA2000 BC0	Power Stage :	High
Test Mode :	1xRTT_RC3+SO55		

Conducted Emission Plot between 30MHz ~ 1GHz

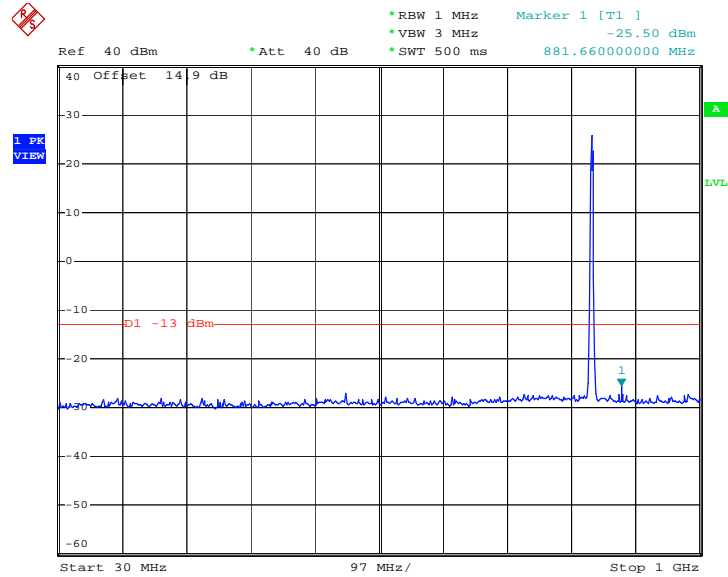

Date: 30.APR.2012 18:30:01

Conducted Emission Plot between 1GHz ~ 3GHz

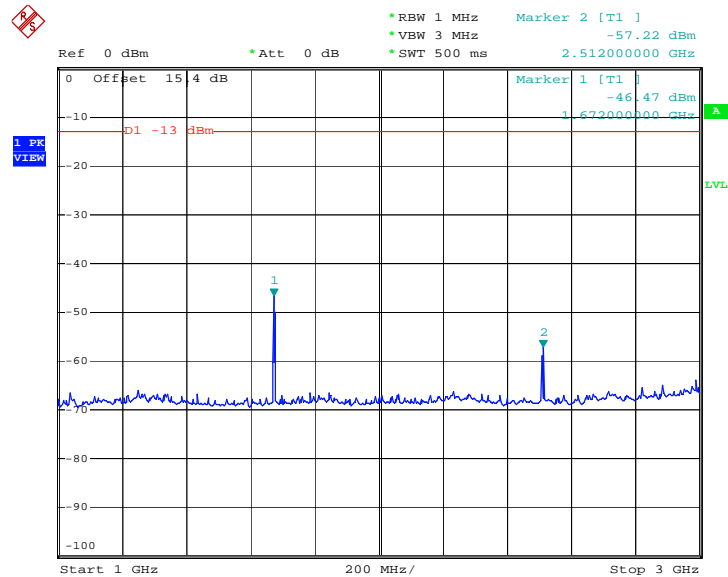

Date: 30.APR.2012 18:31:46



Conducted Emission Plot between 3GHz ~ 7GHz

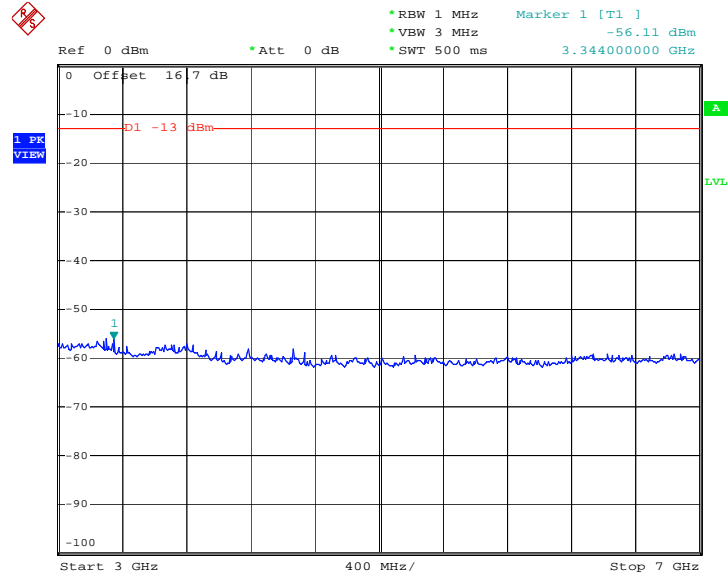

Date: 30.APR.2012 18:35:37

Conducted Emission Plot between 7GHz ~ 9GHz

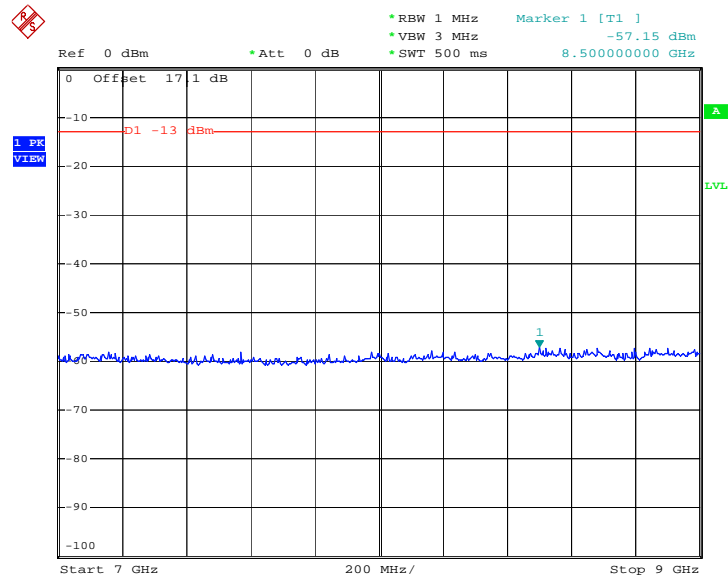

Date: 30.APR.2012 18:34:03



Band :	CDMA2000 BC1	Power Stage :	High
Test Mode :	1xRTT_RC3+SO55		

Conducted Emission Plot between 30MHz ~ 1GHz

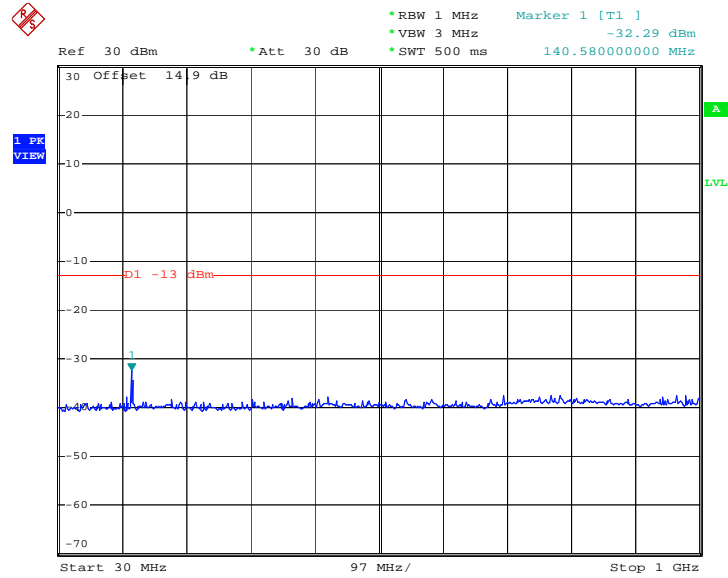

Date: 30.APR.2012 19:40:56

Conducted Emission Plot between 1GHz ~ 3GHz

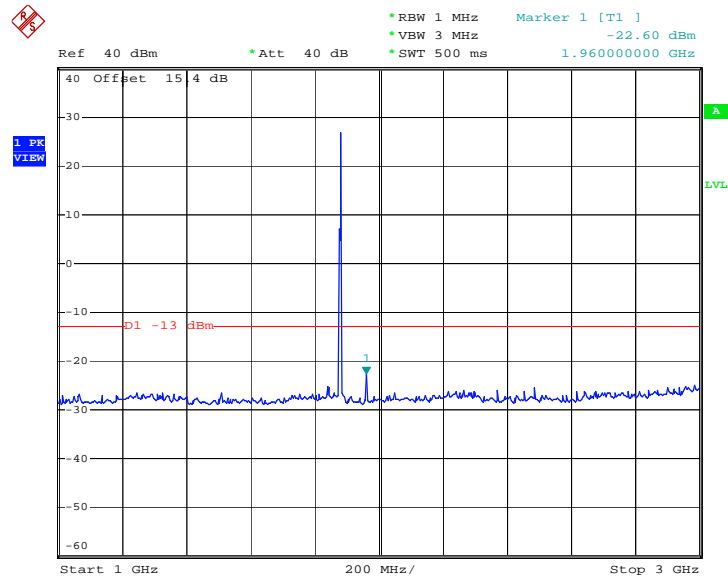

Date: 30.APR.2012 19:41:56



Conducted Emission Plot between 3GHz ~ 7GHz

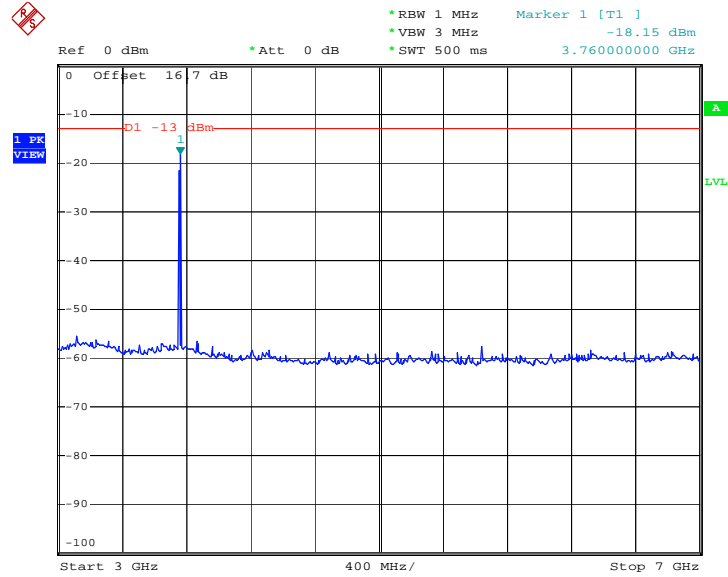

Date: 30.APR.2012 19:43:07

Conducted Emission Plot between 7GHz ~ 13.6GHz

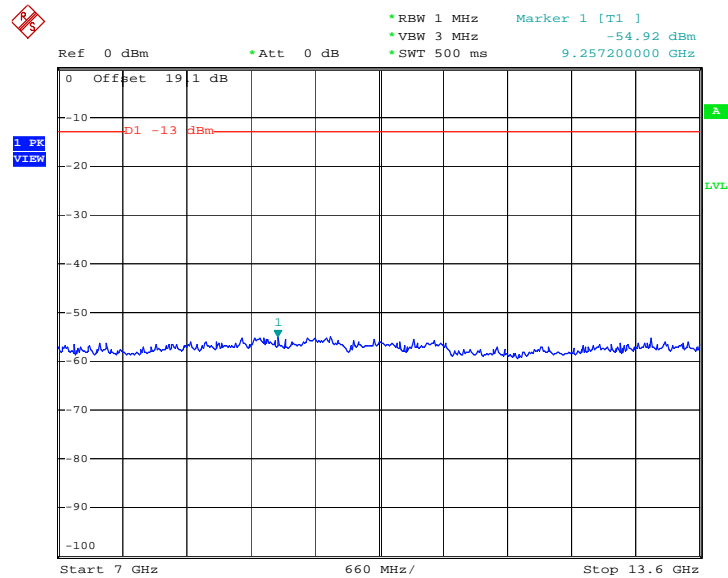

Date: 30.APR.2012 19:44:05



Conducted Emission Plot between 13.6GHz ~ 19.1GHz

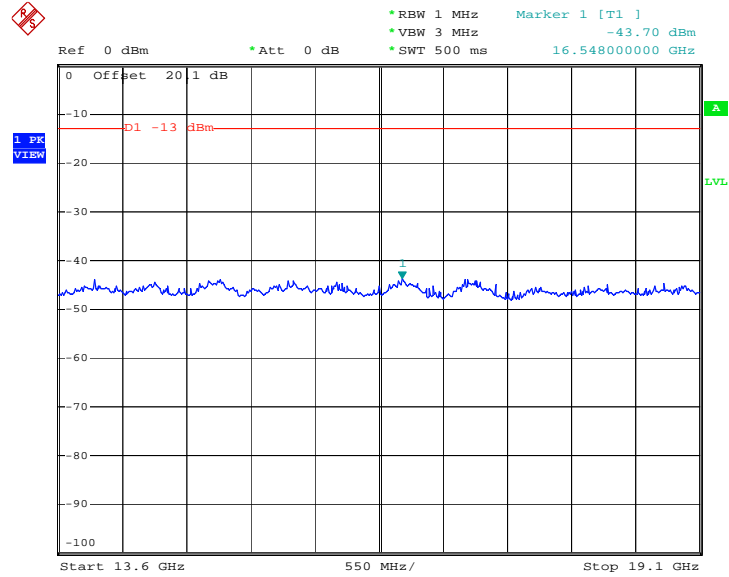

Date: 30.APR.2012 19:45:05



Band :	CDMA2000 BC15	Power Stage :	High
Test Mode :	1xRTT_RC3+SO32		

Conducted Emission Plot between 30MHz ~ 1GHz

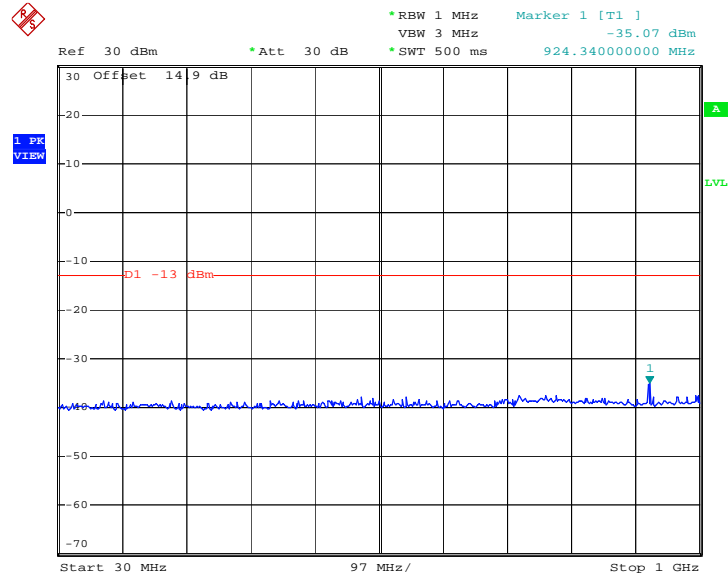

Date: 30.APR.2012 20:45:11

Conducted Emission Plot between 1GHz ~ 3GHz

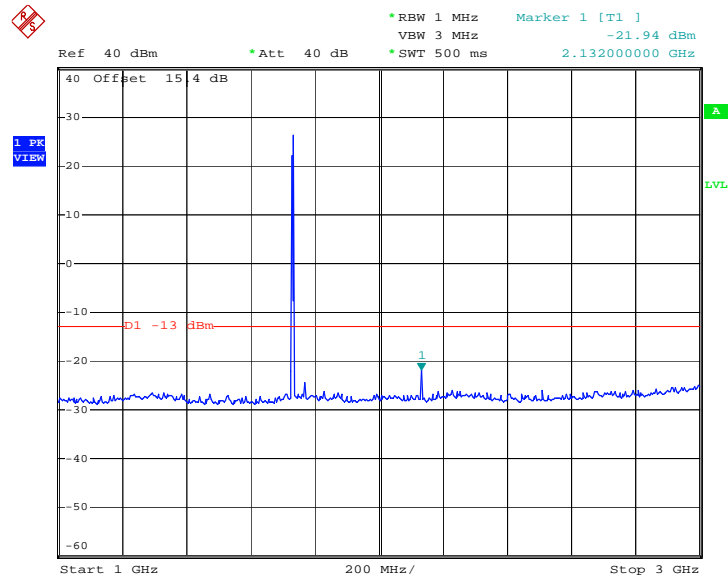

Date: 30.APR.2012 20:46:01



Conducted Emission Plot between 3GHz ~ 7GHz

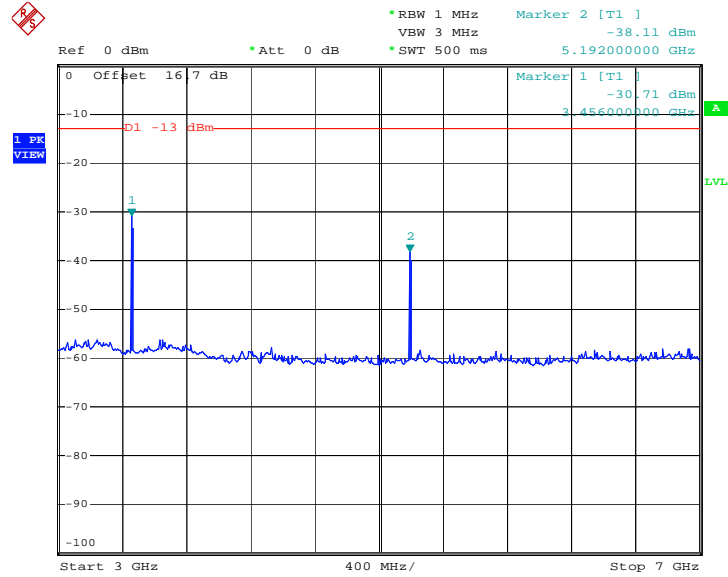

Date: 30.APR.2012 20:48:05

Conducted Emission Plot between 7GHz ~ 13.6GHz

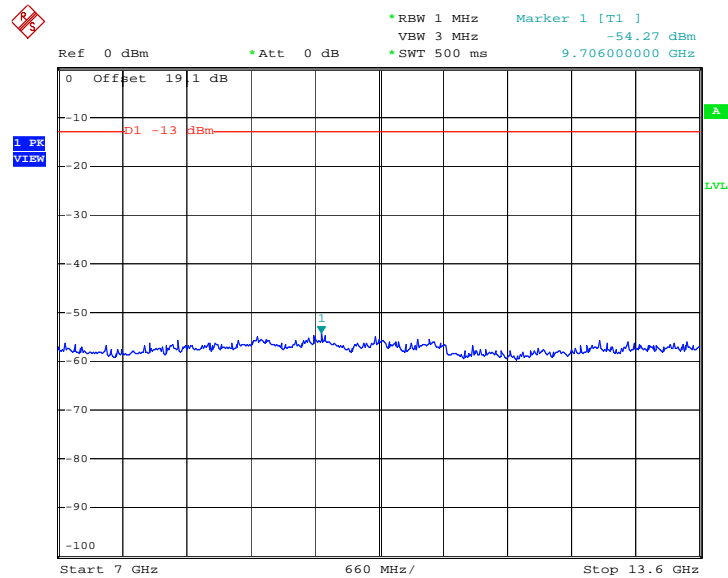

Date: 30.APR.2012 20:49:13



Conducted Emission Plot between 13.6GHz ~ 19.1GHz

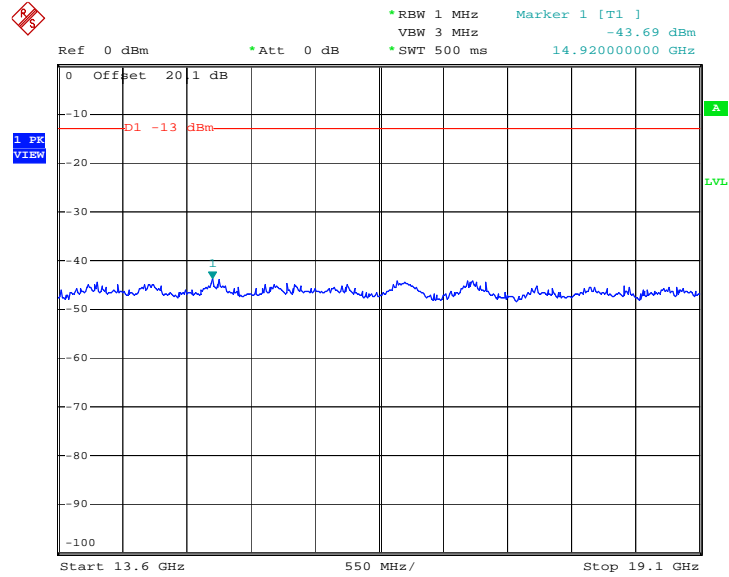

Date: 30.APR.2012 20:50:08

3.6 Field Strength of Spurious Radiation Measurement

3.6.1 Description of Field Strength of Spurious Radiated Measurement

The radiated spurious emission was measured by substitution method according to ANSI / TIA / EIA-603-C-2004. The power of any emission outside of the authorized operating frequency ranges must be attenuated below the transmitter power (P) by a factor of at least $43 + 10 \log (P)$ dB. The spectrum is scanned from 30 MHz up to a frequency including its 10th harmonic.

3.6.2 Measuring Instruments

See list of measuring instruments of this test report.

3.6.3 Test Procedures

1. The EUT was placed on a rotatable wooden table with 0.8 meter about ground.
2. The EUT was set 3 meters from the receiving antenna, which was mounted on the antenna tower.
3. The table was rotated 360 degrees to determine the position of the highest spurious emission.
4. The height of the receiving antenna is varied between one meter and four meters to search the maximum spurious emission for both horizontal and vertical polarizations.
5. Taking the record of maximum spurious emission.
6. A horn antenna was substituted in place of the EUT and was driven by a signal generator.
7. Tune the output power of signal generator to the same emission level with EUT maximum spurious emission.
8. Taking the record of output power at antenna port.
9. Repeat step 7 to step 8 for another polarization.
10. $EIRP \text{ (dBm)} = S.G. \text{ Power} - Tx \text{ Cable Loss} + Tx \text{ Antenna Gain}$
11. $ERP \text{ (dBm)} = EIRP - 2.15$

3.6.4 Test Setup

For radiated emissions below 30MHz

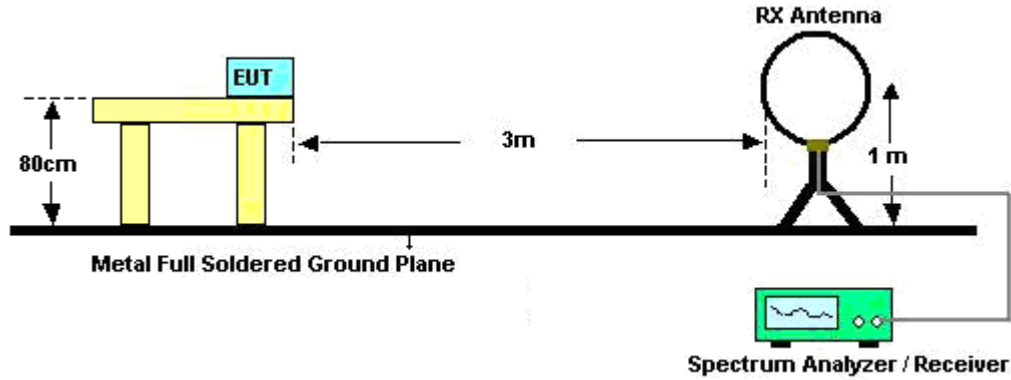

For radiated emissions from 30MHz to 1GHz

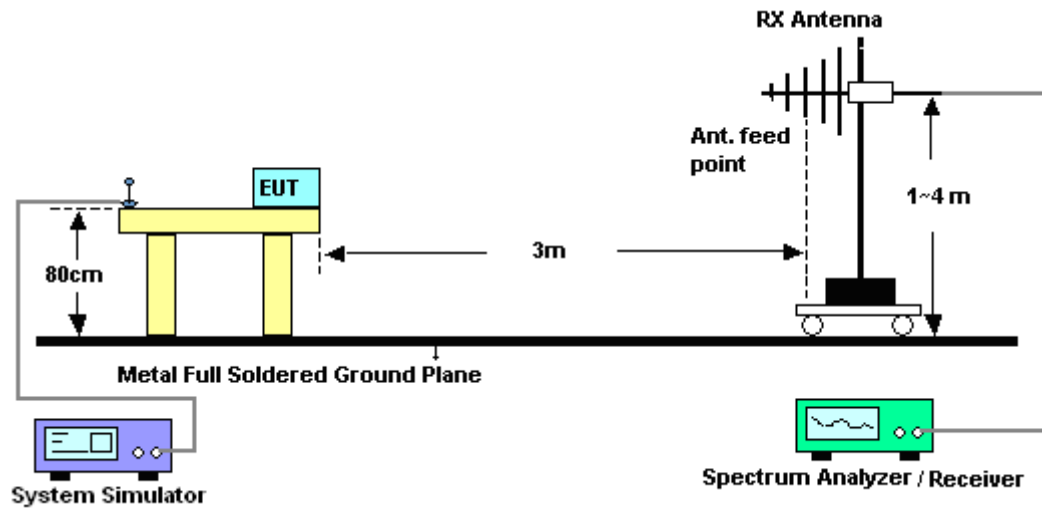

For radiated emissions above 1GHz

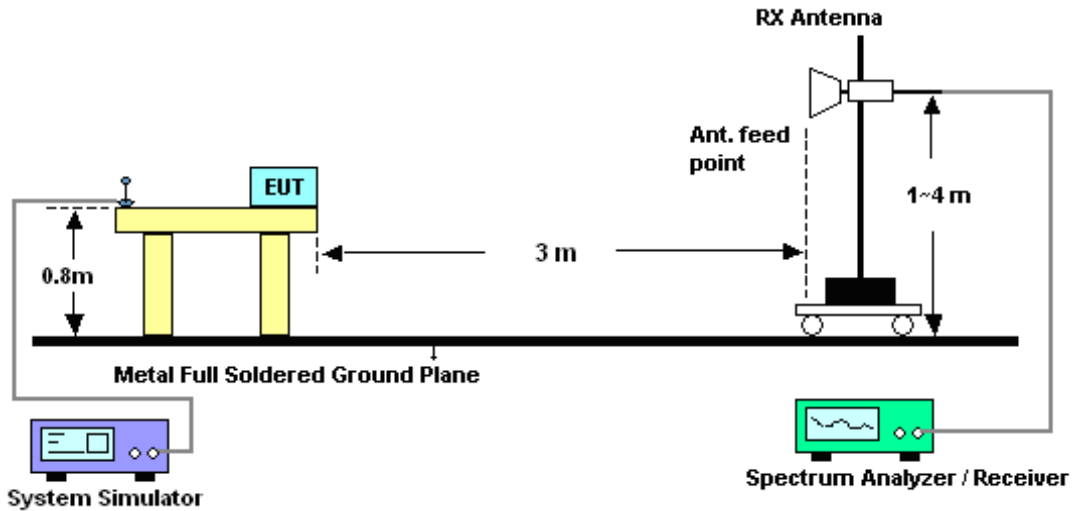

3.6.5 Test Results of Radiated Emissions (9 KHz ~ 30 MHz)

The low frequency, which started from 9 KHz to 30MHz, was pre-scanned and the result which was 20dB lower than the limit line per 15.31(o) was not reported.



3.6.6 Test Result of Field Strength of Spurious Radiated

Band :	CDMA2000 BC0	Temperature :	21~22°C
Test Mode :	1xRTT_RC3+SO55	Relative Humidity :	41~42%
Test Engineer :	Chenmy Cheng	Polarization :	Horizontal
Remark :	Spurious emissions within 30-1000MHz were found more than 20dB below limit line.		

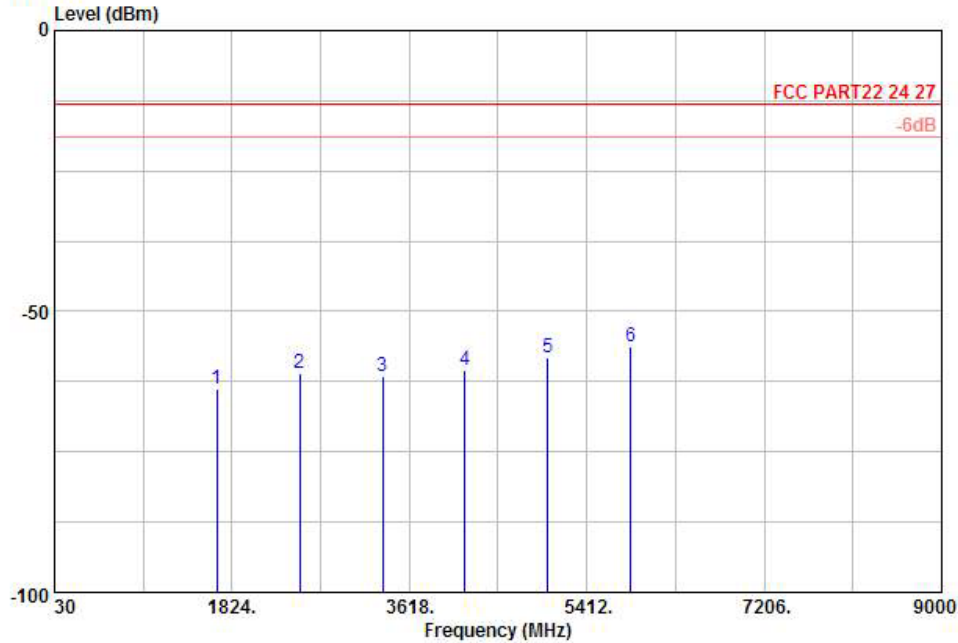

Site : 03CH01-KS
 Condition: FCC PART22 24 27 HF EIRP FACTOR-09020 HORIZONTAL
 Project : (FG) 230902
 plan : E1

Frequency (MHz)	ERP (dBm)	Limit (dBm)	Over Limit (dB)	SPA Reading (dBm)	S.G. Power (dBm)	TX Cable loss (dB)	TX Antenna Gain (dBi)	Polarization (H/V)	Result
1672	-63.77	-13	-50.77	-59.55	-64.42	0.57	3.37	H	Pass
2509	-60.98	-13	-47.98	-63.23	-63.21	0.78	5.16	H	Pass
3345	-61.69	-13	-48.69	-63.63	-65.33	0.87	6.66	H	Pass
4182	-60.40	-13	-47.40	-63.14	-64.99	0.97	7.71	H	Pass
5018	-58.17	-13	-45.17	-64.37	-63.84	1.09	8.91	H	Pass
5854	-56.15	-13	-43.15	-64.86	-62.59	1.22	9.81	H	Pass



Band :	CDMA2000 BC0	Temperature :	21~22°C
Test Mode :	1xRTT_RC3+SO55	Relative Humidity :	41~42%
Test Engineer :	Chenmy Cheng	Polarization :	Vertical
Remark :	Spurious emissions within 30-1000MHz were found more than 20dB below limit line.		

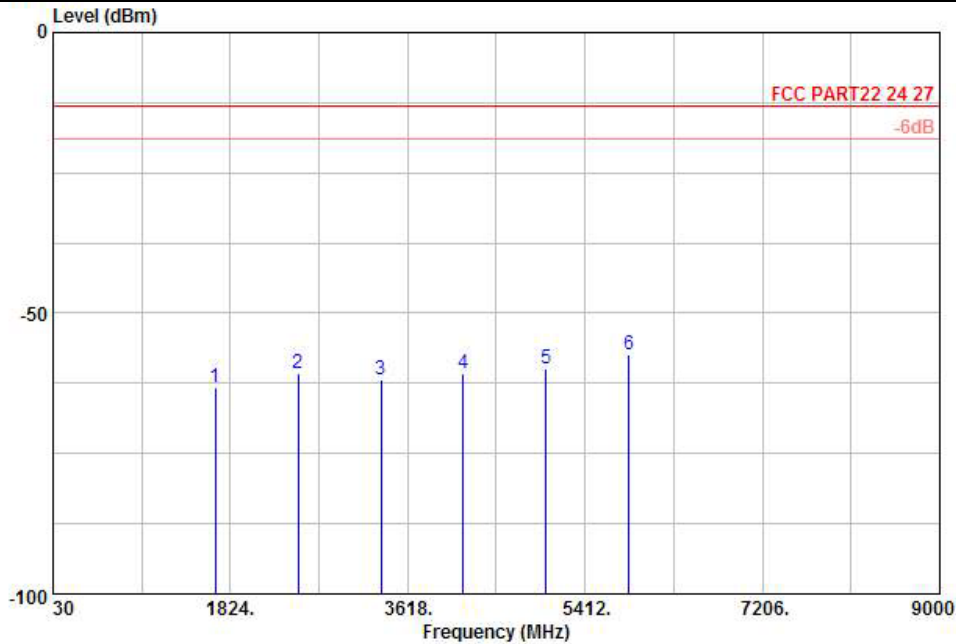

Site : 03CH01-KS
 Condition: FCC PART22 24 27 HF EIRP FACTOR-09020 VERTICAL
 Project : (FG) 230902
 plan : E1

Frequency (MHz)	ERP (dBm)	Limit (dBm)	Over Limit (dB)	SPA Reading (dBm)	S.G. Power (dBm)	TX Cable loss (dB)	TX Antenna Gain (dBi)	Polarization (H/V)	Result
1674	-63.27	-13	-50.27	-58.92	-63.92	0.57	3.37	V	Pass
2509	-60.70	-13	-47.70	-63.81	-62.93	0.78	5.16	V	Pass
3345	-61.89	-13	-48.89	-63.87	-65.53	0.87	6.66	V	Pass
4182	-60.66	-13	-47.66	-64.50	-65.25	0.97	7.71	V	Pass
5018	-59.88	-13	-46.88	-64.82	-65.55	1.09	8.91	V	Pass
5854	-57.30	-13	-44.30	-65.29	-63.74	1.22	9.81	V	Pass



Band :	CDMA2000 BC1	Temperature :	21~22°C
Test Mode :	1xRTT_RC3+SO55	Relative Humidity :	41~42%
Test Engineer :	Chenmy Cheng	Polarization :	Horizontal
Remark :	Spurious emissions within 30-1000MHz were found more than 20dB below limit line.		

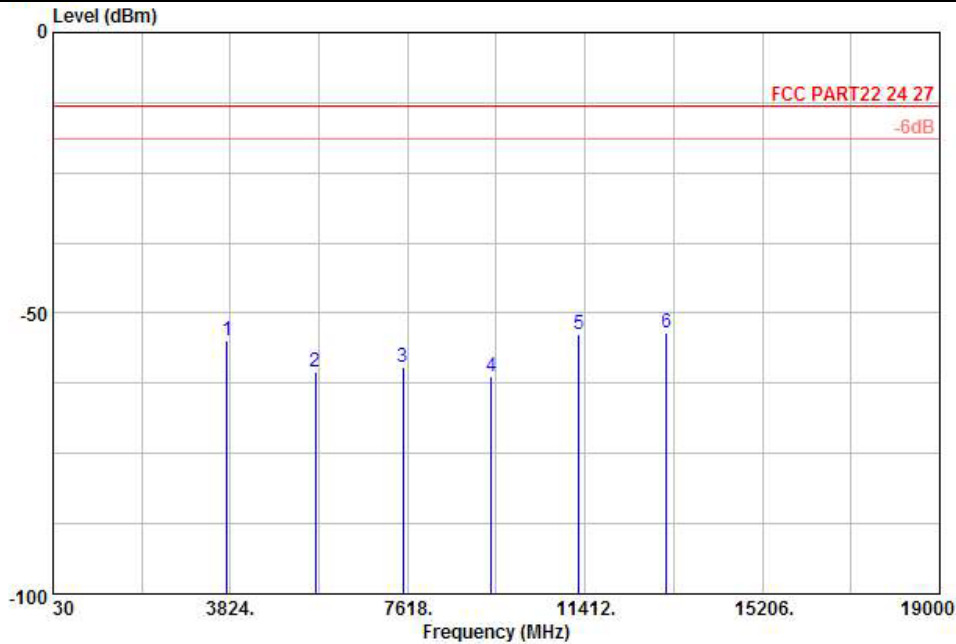

Site : 03CH01-KS
 Condition: FCC PART22 24 27 HF EIRP FACTOR-09020 HORIZONTAL
 Project : (FG) 230902
 plan : E1

Frequency (MHz)	EIRP (dBm)	Limit (dBm)	Over Limit (dB)	SPA Reading (dBm)	S.G. Power (dBm)	TX Cable loss (dB)	TX Antenna Gain (dBi)	Polarization (H/V)	Result
3760	-54.92	-13	-41.92	-55.89	-61.30	0.78	7.16	H	Pass
5640	-60.41	-13	-47.41	-64.59	-68.95	1.04	9.58	H	Pass
7520	-59.54	-13	-46.54	-64.67	-69.65	1.35	11.46	H	Pass
9400	-61.35	-13	-48.35	-64.61	-72.41	1.75	12.81	H	Pass
11280	-53.84	-13	-40.84	-65.33	-64.93	2	13.09	H	Pass
13160	-53.59	-13	-40.59	-64.89	-65.30	2.04	13.75	H	Pass



Band :	CDMA2000 BC1	Temperature :	21~22°C
Test Mode :	1xRTT_RC3+SO55	Relative Humidity :	41~42%
Test Engineer :	Chenmy Cheng	Polarization :	Vertical
Remark :	Spurious emissions within 30-1000MHz were found more than 20dB below limit line.		

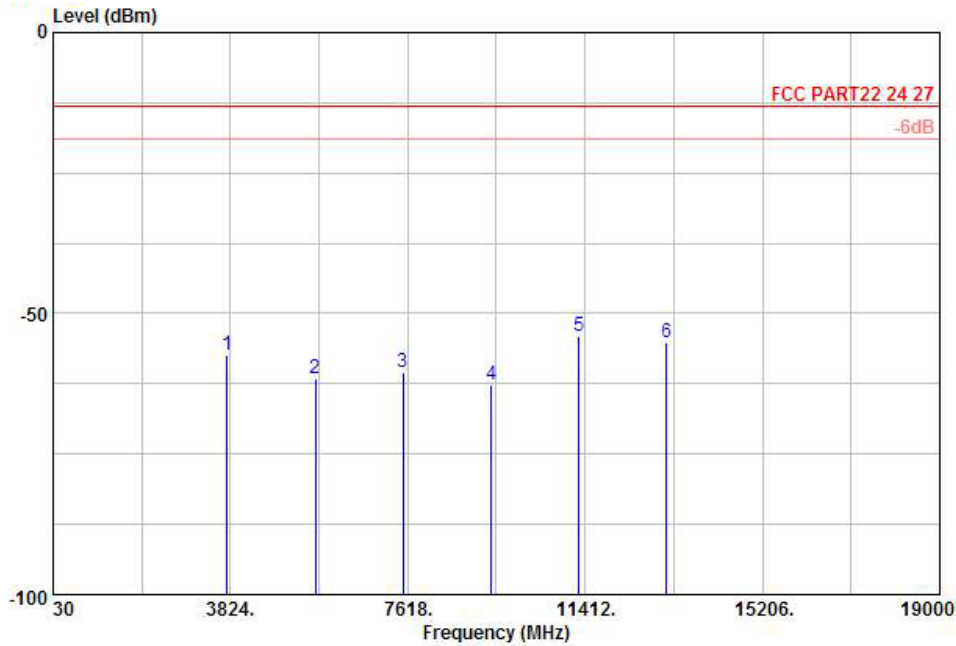

Site : 03CH01-KS
 Condition: FCC PART22 24 27 HF EIRP FACTOR-09020 VERTICAL
 Project : (FG) 230902
 plan : E1

Frequency (MHz)	EIRP (dBm)	Limit (dBm)	Over Limit (dB)	SPA Reading (dBm)	S.G. Power (dBm)	TX Cable loss (dB)	TX Antenna Gain (dBi)	Polarization (H/V)	Result
3760	-57.33	-13	-44.33	-58.7	-63.71	0.78	7.16	V	Pass
5640	-61.50	-13	-48.50	-64.72	-70.04	1.04	9.58	V	Pass
7520	-60.43	-13	-47.43	-64.92	-70.54	1.35	11.46	V	Pass
9400	-62.69	-13	-49.69	-63.91	-73.75	1.75	12.81	V	Pass
11280	-54.02	-13	-41.02	-65.26	-65.11	2	13.09	V	Pass
13160	-55.05	-13	-42.05	-66.24	-66.76	2.04	13.75	V	Pass



Band :	CDMA2000 BC15	Temperature :	21~22°C
Test Mode :	1xRTT_RC3+SO32	Relative Humidity :	41~42%
Test Engineer :	Chenmy Cheng	Polarization :	Horizontal
Remark :	Spurious emissions within 30-1000MHz were found more than 20dB below limit line.		

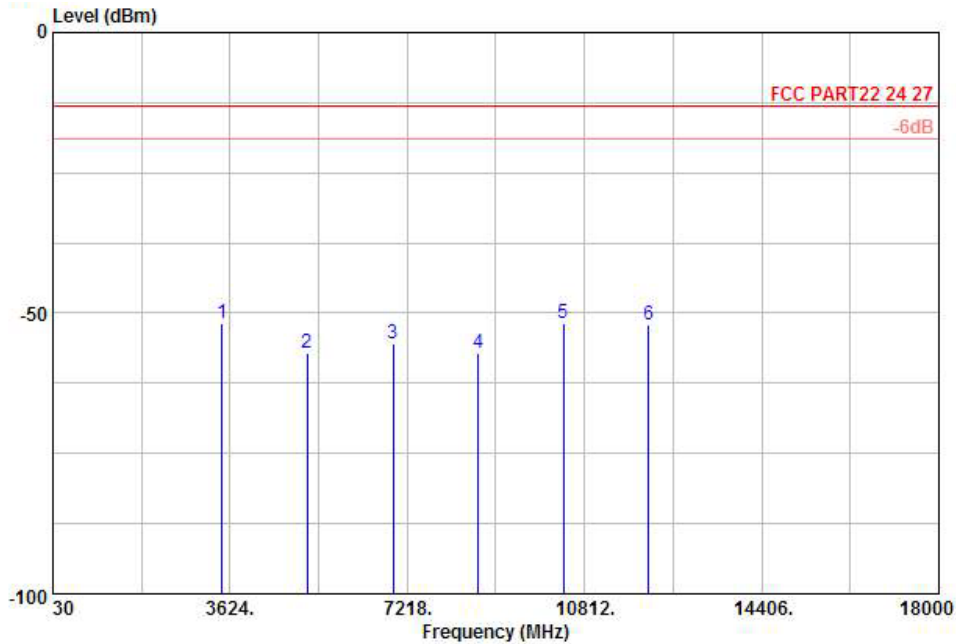

Site : 03CH01-KS
 Condition: FCC PART22 24 27 HF EIRP FACTOR-09020 HORIZONTAL
 Project : (FG) 230902
 plan : E1

Frequency (MHz)	EIRP (dBm)	Limit (dBm)	Over Limit (dB)	SPA Reading (dBm)	S.G. Power (dBm)	TX Cable loss (dB)	TX Antenna Gain (dBi)	Polarization (H/V)	Result
3464	-51.72	-13	-38.72	-59.54	-57.12	2.2	7.60	H	Pass
5193.75	-57.16	-13	-44.16	-64.26	-63.94	3.12	9.90	H	Pass
6925	-55.30	-13	-42.30	-64.36	-63.19	2.98	10.87	H	Pass
8656.25	-57.06	-13	-44.06	-65.13	-66.55	2.97	12.46	H	Pass
10387.5	-51.69	-13	-38.69	-64.43	-60.85	3.46	12.62	H	Pass
12118.75	-52.20	-13	-39.20	-66.22	-60.30	4.5	12.60	H	Pass



Band :	CDMA2000 BC15	Temperature :	21~22°C
Test Mode :	1xRTT_RC3+S032	Relative Humidity :	41~42%
Test Engineer :	Chenmy Cheng	Polarization :	Vertical
Remark :	Spurious emissions within 30-1000MHz were found more than 20dB below limit line.		

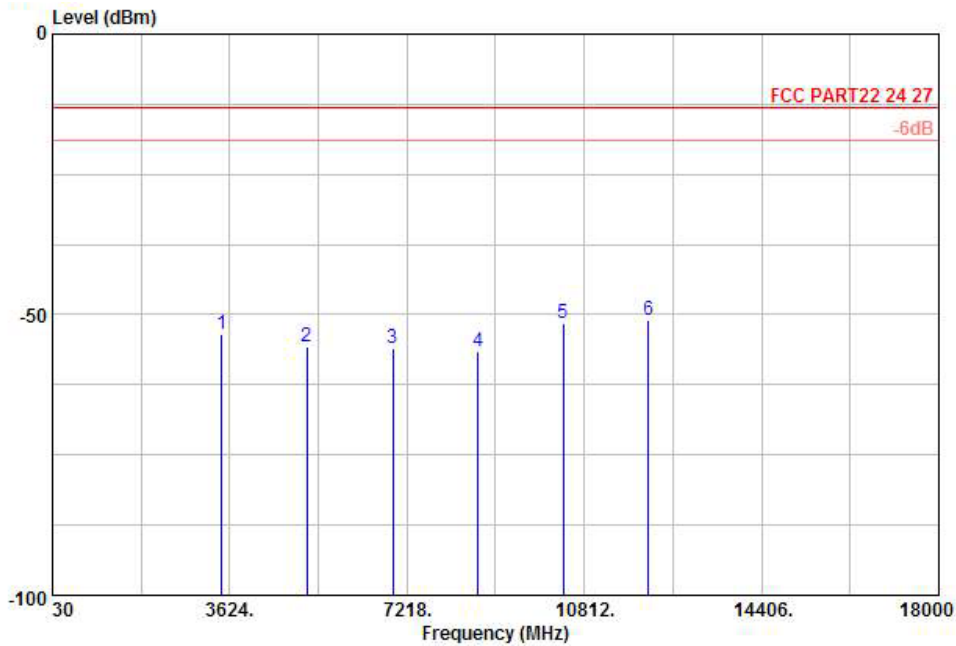

Site : 03CH01-KS
 Condition: FCC PART22 24 27 HF EIRP FACTOR-09020 VERTICAL
 Project : (FG) 230902
 plan : E1

Frequency (MHz)	EIRP (dBm)	Limit (dBm)	Over Limit (dB)	SPA Reading (dBm)	S.G. Power (dBm)	TX Cable loss (dB)	TX Antenna Gain (dBi)	Polarization (H/V)	Result
3464	-53.42	-13	-40.42	-57.98	-58.82	2.2	7.6	V	Pass
5193.75	-55.59	-13	-42.59	-64.75	-62.37	3.12	9.9	V	Pass
6925	-56.08	-13	-43.08	-64.84	-63.97	2.98	10.87	V	Pass
8656.25	-56.48	-13	-43.48	-65.15	-65.97	2.97	12.46	V	Pass
10387.5	-51.66	-13	-38.66	-64.45	-60.82	3.46	12.62	V	Pass
12118.75	-50.92	-13	-37.92	-65.26	-59.02	4.5	12.6	V	Pass

3.7 Frequency Stability Measurement

3.7.1 Description of Frequency Stability Measurement

The frequency stability shall be measured by variation of ambient temperature and variation of primary supply voltage to ensure that the fundamental emission stays within the authorized frequency block. The frequency stability of the transmitter shall be maintained within $\pm 0.00025\%$ ($\pm 2.5\text{ppm}$) of the center frequency.

3.7.2 Measuring Instruments

See list of measuring instruments of this test report.

3.7.3 Test Procedures for Temperature Variation

1. The EUT was set up in the thermal chamber and connected with the base station.
2. With power OFF, the temperature was decreased to -30°C and the EUT was stabilized for three hours. Power was applied and the maximum change in frequency was recorded within one minute.
3. With power OFF, the temperature was raised in 10°C step up to 50°C . The EUT was stabilized at each step for at least half an hour. Power was applied and the maximum frequency change was recorded within one minute.
4. If the EUT cannot be turned on at -30°C , the testing lowest temperature will be raised in 10°C step until the EUT can be turned on.

3.7.4 Test Procedures for Voltage Variation

1. The EUT was placed in a temperature chamber at $25\pm 5^{\circ}\text{C}$ and connected with the base station.
2. The power supply voltage to the EUT was varied from BEP to 115% of the nominal value measured at the input to the EUT.
3. The variation in frequency was measured for the worst case.

3.7.5 Test Setup

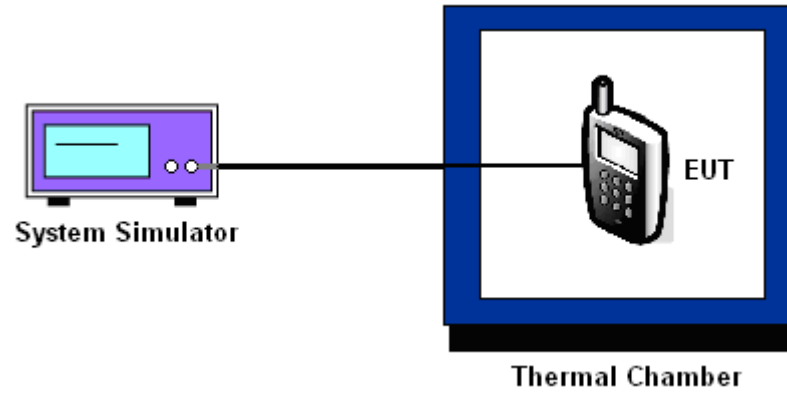



3.7.6 Test Result of Temperature Variation

Band :	CDMA2000 BC0	Channel :	384
Test Mode :	1xRTT_RC3+SO55	Limit (ppm) :	2.5

Temperature (°C)	Freq. Dev. (Hz)	Deviation (ppm)	Result
-30	N/A	N/A	PASS
-20	N/A	N/A	
-10	13	0.02	
0	-6	-0.01	
10	5	0.01	
20	5	0.01	
30	-6	-0.01	
40	-12	-0.01	
50	N/A	N/A	

Note: The manufacturer declared that the EUT could work properly between temperatures -10°C~40°C.

Band :	CDMA2000 BC1	Channel :	600
Test Mode :	1xRTT_RC3+SO55	Limit (ppm) :	2.5

Temperature (°C)	Freq. Dev. (Hz)	Deviation (ppm)	Result
-30	N/A	N/A	PASS
-20	N/A	N/A	
-10	14	0.01	
0	-20	-0.01	
10	33	0.02	
20	21	0.01	
30	-8	0.00	
40	13	0.01	
50	N/A	N/A	

Note: The manufacturer declared that the EUT could work properly between temperatures -10°C~40°C.



Band :	CDMA2000 BC15	Channel :	425
Test Mode :	1xRTT_RC3+SO32	Limit (ppm) :	2.5

Temperature (°C)	Freq. Dev. (Hz)	Deviation (ppm)	Result
-30	N/A	N/A	PASS
-20	N/A	N/A	
-10	6	0.00	
0	-20	-0.01	
10	11	0.01	
20	-9	-0.01	
30	33	0.02	
40	42	0.02	
50	N/A	N/A	

Note: The manufacturer declared that the EUT could work properly between temperatures -10°C~40°C.

3.7.7 Test Result of Voltage Variation

Band & Channel	Mode	Voltage (Volt)	Freq. Dev. (Hz)	Deviation (ppm)	Limit (ppm)	Result
CDMA2000 BC0 CH384	1xRTT RC3+SO55	3.8	-6	-0.01	2.5	PASS
		BEP	7	0.01		
		4.2	8	0.01		
CDMA2000 BC1 CH600	1xRTT RC3+SO55	3.8	-11	-0.01	2.5	PASS
		BEP	-17	-0.01		
		4.2	-15	-0.01		
CDMA2000 BC15 CH425	1xRTT RC3+SO32	3.8	-16	-0.01	2.5	PASS
		BEP	-17	-0.01		
		4.2	-11	-0.01		

Note :

1. Normal Voltage = 3.8V.
2. Battery End Point (BEP) = 3.7 V.



4 List of Measuring Equipments

Instrument	Manufacturer	Model No.	Serial No.	Characteristics	Calibration Date	Test Date	Due Date	Remark
Spectrum Analyzer	R&S	FSP40	100319	9kHz~40GHz	Dec. 30, 2011	Apr. 30, 2012 ~ May 07, 2012	Dec. 29, 2012	Conducted (TH01-KS)
System Simulator	R&S	CMU200	837587/066	2G Full-Band	Dec. 30, 2011	Apr. 30, 2012 ~ May 07, 2012	Dec. 29, 2012	Conducted (TH01-KS)
DC Power Supply	TOPWARD	GPS-3030D	E1884515	N/A	Aug. 23, 2011	Apr. 30, 2012 ~ May 07, 2012	Aug. 22, 2012	Conducted (TH01-KS)
Thermal Chamber	Ten Billion	TTC-B3S	TBN-960502	N/A	Dec. 30, 2011	Apr. 30, 2012 ~ May 07, 2012	Dec. 29, 2012	Conducted (TH01-KS)
EMI Test Receiver	R&S	ESCI	100534	9kHz~3GHz	Nov. 09, 2011	Apr. 28, 2012	Nov. 08, 2012	Radiation (03CH01-KS)
Spectrum Analyzer	R&S	FSP40	100319	9kHz~40GHz	Dec. 30, 2011	Apr. 28, 2012	Dec. 29, 2012	Radiation (03CH01-KS)
Bilog Antenna	SCHAFFNER	CBL6112D	23182	25MHz~2GHz	Dec. 08, 2011	Apr. 28, 2012	Dec. 07, 2012	Radiation (03CH01-KS)
Double Ridge Horn Antenna	EMCO	3117	00075959	1GHz~18GHz	Jan. 06, 2012	Apr. 28, 2012	Jan. 05, 2013	Radiation (03CH01-KS)
Amplifier	Wireless	FPA-6592G	060007	30MHz~2GHz	Dec. 30, 2011	Apr. 28, 2012	Dec. 29, 2012	Radiation (03CH01-KS)
Amplifier	Agilent	8449B	3008A02370	1GHz~26.5GHz	Dec. 30, 2011	Apr. 28, 2012	Dec. 29, 2012	Radiation (03CH01-KS)
SHE-EHF Horn	Schwarzbeck	BBHA9170	BBHA170249	15GHz~40GHz	Oct. 11, 2011	Apr. 28, 2012	Oct. 10, 2012	Radiation (03CH01-KS)
Loop Antenna	R&S	HFH2-Z2	860004/00	9kHz~30 MHz	Jul. 28, 2011	Apr. 28, 2012	Jul. 27, 2012	Radiation (03CH01-KS)
System Simulator	R&S	CMU200	116456	Full-Band	Sep. 20, 2011	Apr. 28, 2012	Sep. 19, 2012	Radiation (03CH01-KS)

5 Uncertainty of Evaluation

Uncertainty of Radiated Emission Measurement (30 MHz ~ 1000 MHz)

Contribution	Uncertainty of X_i		$u(X_i)$
	dB	Probability Distribution	
Receiver Reading	0.41	Normal (k=2)	0.21
Antenna Factor Calibration	0.83	Normal (k=2)	0.42
Cable Loss Calibration	0.25	Normal (k=2)	0.13
Pre-Amplifier Gain Calibration	0.27	Normal (k=2)	0.14
RCV/SPA Specification	2.50	Rectangular	0.72
Antenna Factor Interpolation for Frequency	1.00	Rectangular	0.29
Site Imperfection	1.43	Rectangular	0.83
Mismatch	+0.39 / -0.41	U-Shape	0.28
Combined Standard Uncertainty $U_c(y)$	1.27		
Measuring Uncertainty for a Level of Confidence of 95% ($U = 2U_c(y)$)	2.54		

Uncertainty of Radiated Emission Measurement (1 GHz ~ 40 GHz)

Contribution	Uncertainty of X_i		$u(X_i)$	C_i	$C_i * u(X_i)$
	dB	Probability Distribution			
Receiver Reading	±0.10	Normal (k=2)	0.10	1	0.10
Antenna Factor Calibration	±1.70	Normal (k=2)	0.85	1	0.85
Cable Loss Calibration	±0.50	Normal (k=2)	0.25	1	0.25
Receiver Correction	±2.00	Rectangular	1.15	1	1.15
Antenna Factor Directional	±1.50	Rectangular	0.87	1	0.87
Site Imperfection	±2.80	Triangular	1.14	1	1.14
Mismatch Receiver VSWR $\Gamma_1 = 0.197$ Antenna VSWR $\Gamma_2 = 0.194$ Uncertainty = $20\text{Log}(1-\Gamma_1*\Gamma_2)$	+0.34 / -0.35	U-Shape	0.244	1	0.244
Combined Standard Uncertainty $U_c(y)$	2.36				
Measuring Uncertainty for a Level of Confidence of 95% ($U = 2U_c(y)$)	4.72				



Appendix A. Photographs of EUT

Please refer to Sporton report number EP230902 as below.