

FCC IC RF Test Report

Report No.: FCC_IC_SL20061801-UTC-002_RFID_Rev6

FCC ID: R32-10106653P1

IC: 5058A-10106653P1

Test Model: 10106653P1

Received Date: 01/04/2021

Test Date: 01/14/2021 - 08/19/2022

Issued Date: 01/27/2021

Applicant name: Onity, Inc

Address: 4001 Fairview Industrial Dr. SE, Salem, OR 97302

Manufacturer: Onity, Inc

Address: 4001 Fairview Industrial Dr. SE, Salem, OR 97302

Issued By: Bureau Veritas Consumer Products Services, Inc.

Lab Address: 775 Montague Expressway, Milpitas, CA 95035

**FCC Registration /
Designation Number:** 540430

ISED# / CAB identifier: 4842D



Government
of Canada

Gouvernement
du Canada

**Testing Cert #2742-
01**

US1109

4842D

This report is for your exclusive use. Any copying or replication of this report to or for any other person or entity, or use of our name or trademark, is permitted only with our prior written permission. This report sets forth our findings solely with respect to the test samples identified herein. The results set forth in this report are not indicative or representative of the quality or characteristics of the lot from which a test sample was taken or any similar or identical product unless specifically and expressly noted. Our report includes all of the tests requested by you and the results thereof based upon the information that you provided to us. You have 60 days from date of issuance of this report to notify us of any material error or omission caused by our negligence, provided, however, that such notice shall be in writing and shall specifically address the issue you wish to raise. A failure to raise such issue within the prescribed time shall constitute your unqualified acceptance of the completeness of this report, the tests conducted and the correctness of the report contents. Unless specific mention, the uncertainty of measurement has been explicitly taken into account to declare the compliance or non-compliance to the specification. The report must not be used by the client to claim product certification, approval, or endorsement by A2LA or any government agencies.

Table of Contents

Release Control Record	3
1 Certificate of Conformity	4
2 Summary of Test Results	5
2.1 Measurement Uncertainty	5
2.2 Modification Record	5
3 General Information	6
3.1 General Description of EUT.....	6
3.2 Description of Test Modes	7
3.2.1 1 channel is provided to this EUT	7
3.2.2 Test Mode Applicability and Tested Channel Detail	7
3.3 Description of Support Units.....	8
3.3.1 Configuration of System under Test.....	8
3.4 General Description of Applied Standards	8
4 Test Types and Results	9
4.1 Radiated Emission Measurement.....	9
4.1.1 Limits of Radiated Emission Measurement	9
4.1.2 Test Instruments.....	10
4.1.3 Test Procedures	12
4.1.4 Deviation from Test Standard.....	12
4.1.5 Test Setup.....	13
4.1.6 EUT Operating Conditions.....	13
4.1.7 Test Results	14
4.2 Conducted Emission Measurement.....	19
4.2.1 Limits of Conducted Emission Measurement	19
4.2.2 Test Procedures	19
4.2.3 Deviation from Test Standard.....	19
4.2.4 Test Setup.....	19
4.2.5 EUT Operating Conditions.....	19
4.2.6 Test Results	19
4.3 Frequency Stability	20
4.3.1 Limits of Frequency Stability Measurement.....	20
4.3.2 Test Setup.....	20
4.3.3 Test Instruments.....	20
4.3.4 Test Procedure.....	20
4.3.5 Deviation from Test Standard	20
4.3.6 EUT Operating Conditions.....	20
4.3.7 Test Result	21
4.4 20dB Bandwidth.....	22
4.4.1 Limits of 20dB Bandwidth Measurement.....	22
4.4.2 Test Setup.....	22
4.4.3 Test Instruments.....	22
4.4.4 Test Procedures	22
4.4.5 Deviation from Test Standard.....	22
4.4.6 EUT Operating Conditions.....	22
4.4.7 Test Results	23
5 Pictures of Test Arrangements	24
Appendix – Information on the Testing Laboratories	25

Release Control Record

Issue No.	Description	Engineer	Reviewer	Date Issued
FCC_IC_RF_SL20061801-UTC-002_RFID	Original Release	EC	DD	01/27/2021
FCC_IC_RF_SL20061801-UTC-002_RFID_Rev1	Errors Correction			04/26/2022
FCC_IC_RF_SL20061801-UTC-002_RFID_Rev2	Errors Correction	BQ	SK	08/22/2022
FCC_IC_RF_SL20061801-UTC-002_RFID_Rev3	Errors Correction	BQ	SK	08/30/2022
FCC_IC_RF_SL20061801-UTC-002_RFID_Rev4	Errors Correction	BQ	SK	09/20/2022
FCC_IC_RF_SL20061801-UTC-002_RFID_Rev5	Errors Correction	BQ	SK	09/28/2022
FCC_IC_RF_SL20061801-UTC-002_RFID_Rev6	Errors Correction	BQ	SK	09/28/2022

1 Certificate of Conformity

Product: Serene Lock
Brand: Onity
Test Model: 10106653P1
Series Model: N/A
Sample Status: Engineering sample
Applicant: Onity, Inc.
Test Date: 01/14/2021 - 08/19/2022
Standards: 47 CFR FCC Part 15, Subpart C (Section 15.225)
RSS 210 Issue 10, December 2019
ANSI C63.10:2013
RSS Gen Issue 5, March 2019

The above equipment has been tested by **Bureau Veritas Consumer Products Services, Inc., Milpitas Branch**, and found compliance with the requirement of the above standards. The test record, data evaluation & Equipment Under Test (EUT) configurations represented herein are true and accurate accounts of the measurements of the sample's EMC characteristics under the conditions specified in this report.

Prepared by :  _____, **Date:** 01/27/2021
Ellen Chu / Test Engineer

Approved by :  _____, **Date:** 01/27/2021
Deon Dai / Engineer Review

2 Summary of Test Results

47 CFR FCC Part 15, Subpart C (Section 15.225 / 15.215)			
RSS 210 Issue 10, RSS Gen Issue 5			
FCC IC Clause	Test Item	Result	Remarks
15.207 RSS Gen 8.8	AC Power Conducted Emission	NA	EUT is battery powered.
15.225 (a) RSS 210 B.6.a.i	The field strength of any emissions within the band 13.553-13.567 MHz	Pass	Meet the requirement of limit.
15.225 (b) RSS 210 B.6.a.ii	The field strength of any emissions within the bands 13.410-13.553 MHz and 13.567-13.710 MHz	Pass	Meet the requirement of limit.
15.225 (c) RSS 210 B.6.a.iii	The field strength of any emissions within the bands 13.110-13.410 MHz and 13.710-14.010 MHz	Pass	Meet the requirement of limit.
15.225 (d) RSS Gen	The field strength of any emissions appearing outside of the 13.110-14.010 MHz band	Pass	Meet the requirement of limit.
15.225 (e) RSS 210 B.6.b	The frequency tolerance	Pass	Meet the requirement of limit.
15.215 (c) RSS Gen 6.7	20dB Bandwidth & 99% Bandwidth	Pass	Meet the requirement of limit.

2.1 Measurement Uncertainty

Where relevant, the following measurement uncertainty levels have been estimated for tests performed on the EUT as specified in CISPR 16-4-2:

Measurement	Frequency	Expanded Uncertainty (k=2) (±)
Conducted Emissions at mains ports	150kHz ~ 30MHz	3.51dB
Radiated Emissions up to 1 GHz	30MHz ~ 1GHz	3.73dB

2.2 Modification Record

There were no modifications required for compliance.

3 General Information

3.1 General Description of EUT

Product	Serene Lock
Brand	Onity
Test Model	10106653P1
Status of EUT	Engineering sample
Power Supply Rating	6Vdc
Modulation Type	ASK
Operating Frequency	13.56 MHz
Antenna Type	Loop antenna
Antenna inductance	1uH nominal

Note:

1. The above EUT information is declared by the manufacturer. For more details, please refer to the manufacturer's specifications or user's manual.

3.2 Description of Test Modes

3.2.1 1 channel is provided to this EUT

Channel	Freq. (MHz)
1	13.56

RFID is a PCB type antenna, Execute the command Software provided by customer and it will transmit continuously the 13.56MHz.

3.2.2 Test Mode Applicability and Tested Channel Detail

EUT CONFIGURE MODE	APPLICABLE TO				DESCRIPTION
	RE	PLC	FS	EB	
-	√	-	√	√	Power from battery

Where **RE**: Radiated Emission **PLC**: Power Line Conducted Emission
FS: Frequency Stability **EB**: 20dB Bandwidth measurement

NOTE: The EUT had been pre-tested on the positioned of each 3 axis. The worst case was found when positioned on **Y-plane**.

NOTE: "-" means no effect.

Radiated Emission Test:

- Pre-Scan has been conducted to determine the worst-case mode from all possible combinations between available modulations, data rates and antenna ports (if EUT with antenna diversity architecture).
- Following channel(s) was (were) selected for the final test as listed below.

EUT Configure Mode	Available Channel	Tested Channel	Modulation Type
-	1	1	ASK

Frequency Stability:

- Pre-Scan has been conducted to determine the worst-case mode from all possible combinations between available modulations, data rates and antenna ports (if EUT with antenna diversity architecture).
- Following channel(s) was (were) selected for the final test as listed below.

EUT Configure Mode	Available Channel	Tested Channel	Modulation Type
-	1	1	ASK

Test Condition:

APPLICABLE TO	ENVIRONMENTAL CONDITIONS	INPUT POWER	TESTED BY
RE	25deg. C, 65%RH	6Vdc	Ellen Chu
PLC	25deg. C, 65%RH	-	-
FS	25deg. C, 68%RH	6Vdc	Ellen Chu
BW	21deg. C, 60%RH	6Vdc	Ellen Chu

3.3 Description of Support Units

The EUT has been tested as an independent unit together with other necessary accessories or support units. The following support units or accessories were used to form a representative test configuration during the tests.

ID	Product	Brand	Model No.	Serial No.	FCC ID	Remarks
A.	Laptop	Dell	Latitude D630	84V6QF1	-	Provided by Customer
B.						

ID	Descriptions	Qty.	Length (m)	Shielding (Yes/No)	Cores (Qty.)	Remarks
1.	Blue Giga USB dongle	1	0.02	N	0	Connect from EUT to Laptop

Note: The core(s) is(are) originally attached to the cable(s).

3.3.1 Configuration of System under Test

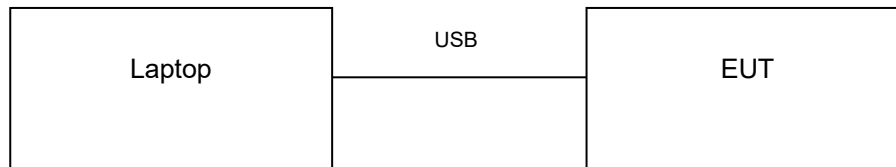

3.4 General Description of Applied Standards

The EUT is a RF Product. According to the specifications of the manufacturer, it must comply with the requirements of the following standards:

47 CFR FCC Part 15, Subpart C (Section 15.225)

47 CFR FCC Part 15, Subpart C (Section 15.215)

RSS 210 Issue 10, Decemeber 2019

ANSI C63.10:2013

RSS Gen Issue 5, March 2019

All test items have been performed and recorded as per the above standards.

4 Test Types and Results

4.1 Radiated Emission Measurement

4.1.1 Limits of Radiated Emission Measurement

The field strength of any emissions within the band 13.553-13.567 MHz shall not exceed 15,848 microvolts/meter at 30 meters.

Within the bands 13.410-13.553 MHz and 13.567-13.710 MHz, the field strength of any emissions shall not exceed 334 microvolts/meter at 30 meters.

Within the bands 13.110-13.410 MHz and 13.710-14.010 MHz the field strength of any emissions shall not exceed 106 microvolts/meter at 30 meters.

The field strength of any emissions appearing outside of the 13.110-14.010 MHz band shall not exceed the general radiated emission limits in § 15.209.

Frequencies (MHz)	Field Strength (microvolts/meter)	Measurement Distance (meters)
0.009 ~ 0.490	2400/F(kHz)	300
0.490 ~ 1.705	24000/F(kHz)	30
1.705 ~ 30.0	30	30
30 ~ 88	100	3
88 ~ 216	150	3
216 ~ 960	200	3
Above 960	500	3

NOTE:

1. The lower limit shall apply at the transition frequencies.
2. Distance extrapolation factor = $40 \log (\text{specific distance} / \text{test distance})$
 Limit Line (dBuV/m) = $20 \log \text{Emission level (uV/m)} + \text{Distance extrapolation factor}$
3. For frequencies above 1000MHz, the field strength limits are based on average detector, however, the peak field strength of any emission shall not exceed the maximum permitted average limits, specified above by more than 20dB under any condition of modulation.

4.1.2 Test Instruments

Test Instruments for Testing Conducted in 2021

DESCRIPTION & MANUFACTURER	MODEL NO.	SERIAL NO.	DATE OF CALIBRATION	DUE DATE OF CALIBRATION
EMI Test Receiver Keysight	ESW 44	1328.4100K- 101662-MH	08/30/2020	08/30/2021
Spectrum Analyzer Keysight	N9030B	0240376	06/15/2020	06/15/2021
Hybrid Antenna Sunoi	JB1	A030702	03/09/2020	03/09/2021
Horn Antenna ETS-Lindgren	3117	218554	11/22/2020	11/22/2021
Preamplifier RF-Lambda	RAMP00M50GA	17032300048	06/18/2020	06/18/2021
Preamplifier RF Bay, Inc.	LPA-6-30	11170601	04/27/2020	04/27/2021
FSB Antenna Cable, 0.5m (Microwave Town)	FSB360PK-KMKM- 00.50M	201906110002	10/1/2020	10/1/2021
FSB Antenna Cable, 4m (Microwave Town)	FSB360PK-KMKM- 400M	202103270001	10/1/2020	10/1/2021
10m Semi-Anechoic Chamber (ETS-Lindgren)	S2010BL8X8	1462	07/21/2020	07/21/2021

Test Instruments for Testing Conducted in 2022

Description & Manufacturer	MODEL NO.	SERIAL NO.	DATE OF CALIBRATION	DUE DATE OF CALIBRATION
Spectrum Analyzer Keysight	N9030B	MY57140100	9/22/2021	9/22/2022
EMI Test Receiver Rohde & Schwarz	ESW44	1328.4100K44-101662-MH	9/22/2021	9/22/2022
Horn Antenna ETS-Lindgren	3117	214309	4/21/2021	4/21/2023
Horn Antenna, Sunol	DRH-118	A070605	8/5/2020	08/05//2022
Pre-Amplifier RF-Lambda	RAMP00M50GA	1.8E+10	5/7/2021	5/7/2022
Biconilog Antenna, Sunol	JB1	A111717	9/4/2020	9/4/2022
Agilent Signal Generator	MXG- N5182A	MY47071065	9/22/2021	9/22/2022
Tuned Dipole Antenna 30 - 1000 MHz (4pcs set)	AD-100	40133	1/23/2022	1/23/2023
SMA Fixed Attenuator (50ohm, 2w, 30dB, DC-6GHz)	VAT-03W2+	N/A	7/21/2021	7/21/2022
FSB Antenna Cable, 0.5m (Microwave Town)	FSB360PK-KMKM- 00.50M	2.02E+11	10/1/2021	10/1/2022
FSB Antenna Cable, 4m (Microwave Town)	FSB360PK-KMKM- 400M	2.02E+11	10/1/2021	10/1/2022
10m Semi- Anechoic Chamber (ETS- Lindgren)	S2010BL8X8	1462	7/21/2020	7/21/2022

4.1.3 Test Procedures

For Radiated emission below 30MHz

- a. The EUT was placed on the top of a rotating table 0.8 meters above the ground at a 3 meter chamber room. The table was rotated 360 degrees to determine the position of the highest radiation.
- b. The EUT was set 3 meters away from the interference-receiving antenna, which was mounted on the top of a variable-height antenna tower.
- c. Parallel and perpendicular orientations of the antenna are set to make the measurement.
- d. For each suspected emission, the EUT was arranged to its worst case and the rotatable table was turned from 0 degrees to 360 degrees to find the maximum reading.
- e. The test-receiver system was set to Quasi-Peak Detect Function and Specified Bandwidth with Maximum Hold Mode.

NOTE:

1. The resolution bandwidth and video bandwidth of test receiver/spectrum analyzer is 9 kHz at frequency below 30MHz.

For Radiated emission above 30MHz

- a. The EUT was placed on the top of a rotating table 0.8 meters (for 30MHz ~ 1GHz) / 1.5 meters (for above 1GHz) above the ground at 3 meter chamber room for test. The table was rotated 360 degrees to determine the position of the highest radiation.
- b. The EUT was set 3 meters away from the interference-receiving antenna, which was mounted on the top of a variable-height antenna tower.
- c. The height of antenna is varied from one meter to four meters above the ground to determine the maximum value of the field strength. Both horizontal and vertical polarizations of the antenna are set to make the measurement.
- d. For each suspected emission, the EUT was arranged to its worst case and then the antenna was tuned to heights from 1 meter to 4 meters and the rotatable table was turned from 0 degrees to 360 degrees to find the maximum reading.
- e. The test-receiver system was set to quasi-peak detect function and specified bandwidth with maximum hold mode when the test frequency is below 1 GHz.
- f. The test-receiver system was set to peak and average detects function and specified bandwidth with maximum hold mode when the test frequency is above 1 GHz. If the peak reading value also meets average limit, measurement with the average detector is unnecessary.

Note:

1. The resolution bandwidth and video bandwidth of test receiver/spectrum analyzer is 120 kHz for Quasi-peak detection (QP) at frequency below 1GHz.
2. The resolution bandwidth of test receiver/spectrum analyzer is 1 MHz and the video bandwidth is 3 MHz for Peak detection (PK) at frequency above 1GHz.
3. The resolution bandwidth of test receiver/spectrum analyzer is 1MHz and the video bandwidth is $\geq 1/T$ (Duty cycle < 98%) or 10Hz (Duty cycle $\geq 98\%$) for Average detection (AV) at frequency above 1GHz.
4. All modes of operation were investigated and the worst-case emissions are reported.

4.1.4 Deviation from Test Standard

No deviation.

4.1.5 Test Setup

For Radiated emission below 30MHz

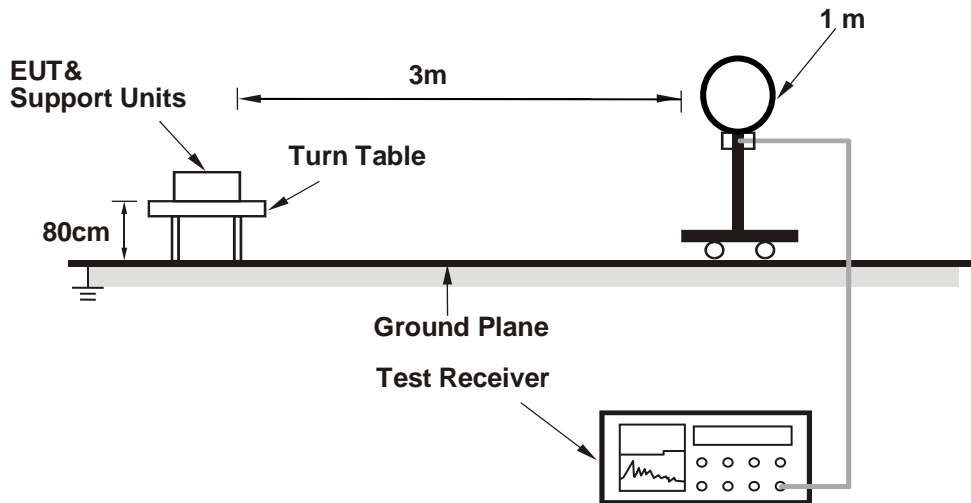

For Radiated emission 30MHz to 1GHz

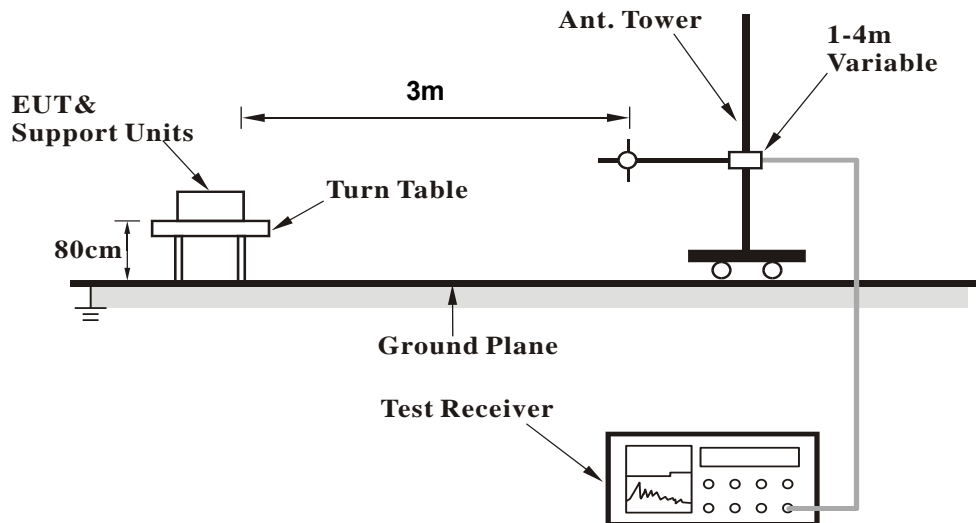

4.1.6 EUT Operating Conditions

- Connected the EUT with the Notebook Computer which is placed on remote site.
- Controlling software has been activated to set the EUT on specific status.

4.1.7 Test Results

Radiated Emissions (9 kHz~30 MHz)

Date Tested	08/15/2022		
Channel	Channel 1	Frequency Range	13.56MHz
Input Power	DC6V	Detector Function	Quasi-Peak
Environmental Conditions	26.8 deg. C, 36.3% RH	Tested By	Brandon Quan

Antenna Polarity & Test Distance: Loop Antenna H-Polarity At 3m

No.	Frequency (MHz)	Polarization	Reading QP [dB(uV)]	Factor [dB(1/m)]	Level QP [dB(uV/m)]	Limit QP dB(uV/m)	Margin QP [dB]	30m Level [dB(uV/m)]	30m Limit [dB(uV/m)]	30m Margin [dB]	Height (cm)	Angle (Deg)	Pass/Fail
1	0.011	H	43.5	51.4	94.9	126.9	32	54.9	N/A	N/A	100	341.8	Pass
2	0.022	H	37.3	46.5	83.8	120.9	37.1	43.8	N/A	N/A	100	47.5	Pass
3	0.494	H	29	18.4	47.4	73.7	26.3	7.4	N/A	N/A	100	42	Pass
4	0.908	H	24.8	13.5	38.3	68.4	30.1	-1.7	N/A	N/A	100	85.4	Pass
5	1.585	H	20.2	9.6	29.8	63.6	33.8	-10.2	N/A	N/A	100	283.8	Pass
6	13.56	H	55.1	1.6	56.7	124	67.3	16.7	84	67.3	100	185.2	Pass

REMARKS:

1. Level (dBuV) = Reading (dBuV) + Factor (dB(1/m)).
2. Factor (dB(1/m)) = Antenna Factor(AF) (dB(1/m)) + Cable Loss (dB)
3. Margin value = Emission level – Limit value.
4. All emissions higher than the fundamental are noise floor measurements.

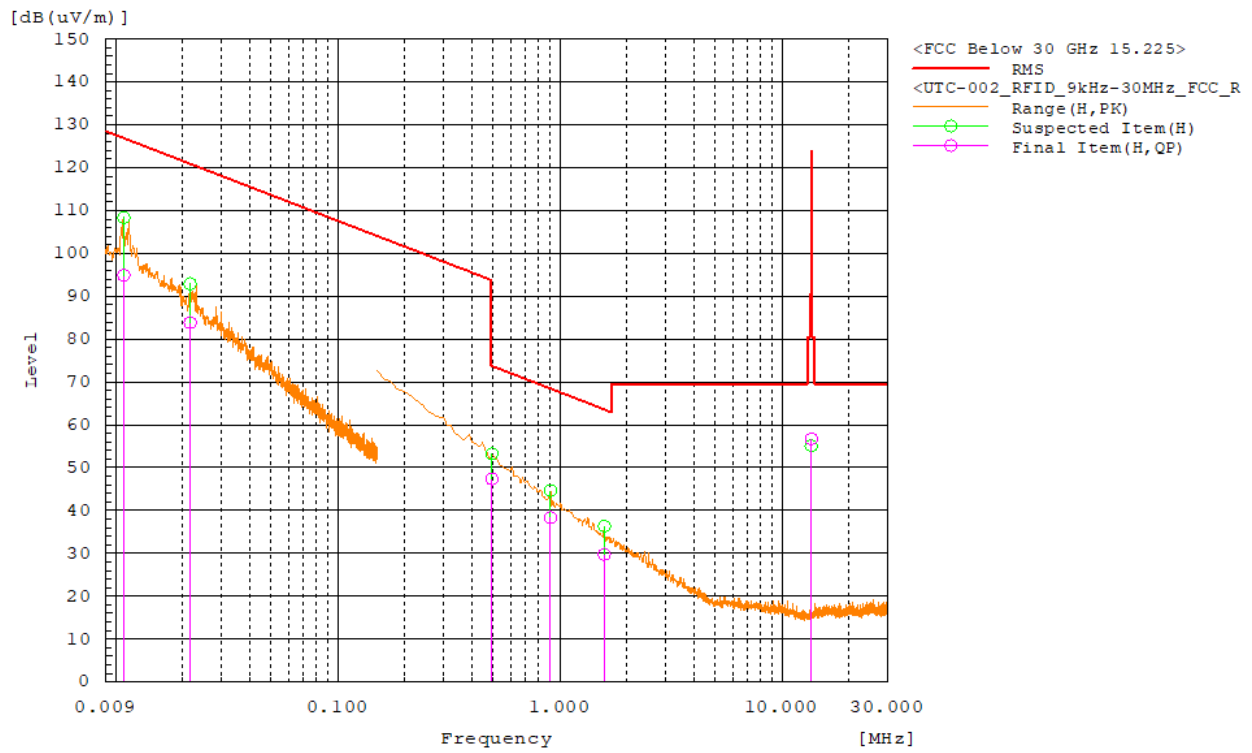

Date Tested	08/15/2022		
Channel	Channel 1	Frequency Range	Below 30MHz
Input Power	DC6V	Detector Function	Quasi-Peak
Environmental Conditions	26.8 deg. C, 36.3% RH	Tested By	Brandon Quan

Antenna Polarity & Test Distance: Loop Antenna V-Polarity At 3m

No.	Frequency (MHz)	Polarization	Reading QP [dB(uV)]	Factor [dB(1/m)]	Level QP [dB(uV/m)]	Limit QP [dB(uV/m)]	Margin QP [dB]	30m Level [dB(uV/m)]	30m Limit [dB(uV/m)]	30m Margin [dB]	Height (cm)	Angle (Deg)	Pass/Fail
1	0.011	V	43.1	51.4	94.5	126.8	32.3	54.5	N/A	N/A	100	95.6	Pass
2	0.494	V	28.9	18.4	47.3	73.7	26.4	7.3	N/A	N/A	100	358.7	Pass
3	0.552	V	27.9	17.5	45.4	72.8	27.4	5.4	N/A	N/A	100	26.1	Pass
4	1.218	V	23.1	11.4	34.5	65.9	31.4	-5.5	N/A	N/A	100	268.8	Pass
5	13.56	V	49.1	1.6	50.7	124	73.3	10.7	N/A	N/A	100	92.6	Pass
6	25.993	V	4.2	1.9	6.1	69.5	63.4	-33.9	84	117.9	100	0	Pass

REMARKS:

1. Level (dBuV) = Reading (dBuV) + Factor (dB(1/m)).
2. Factor (dB(1/m)) = Antenna Factor(AF) (dB(1/m)) + Cable Loss (dB)
3. Margin value = Emission level – Limit value.
4. All emissions higher than the fundamental are noise floor measurements.

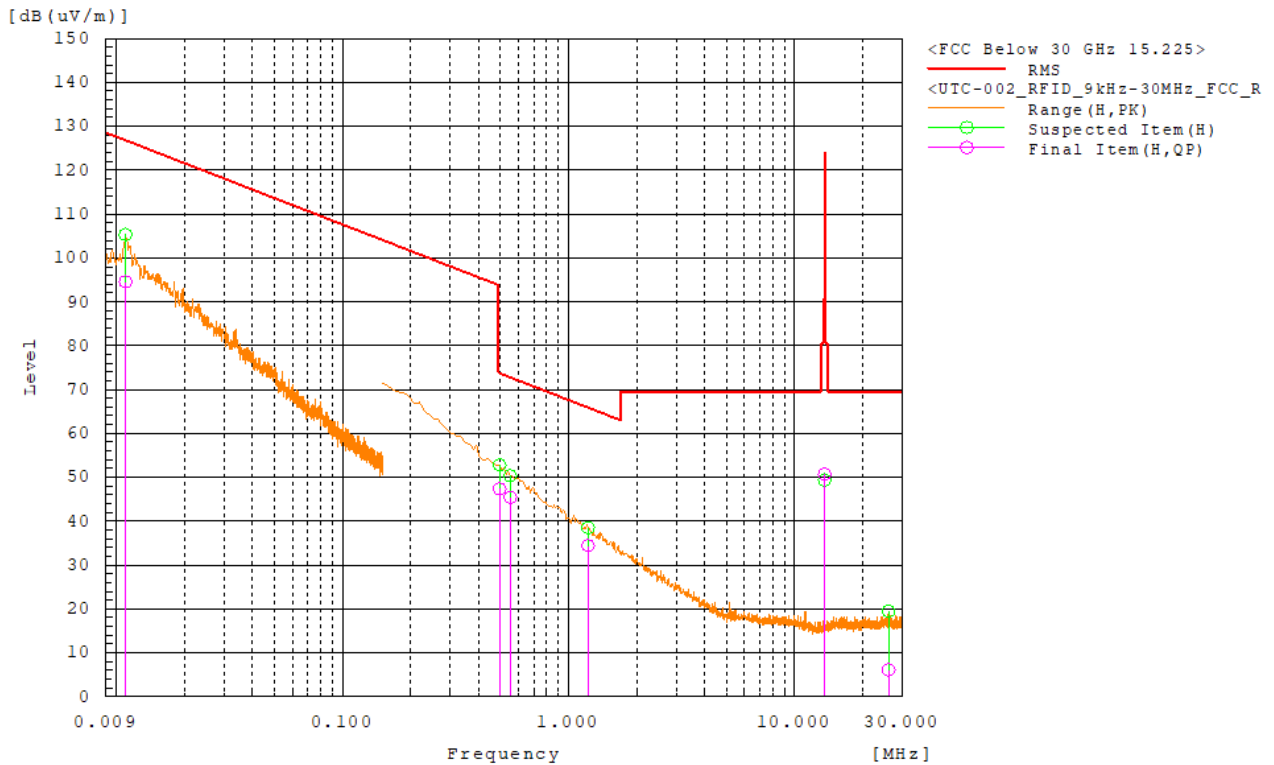

EUT Test Condition	08/15/2022		
Channel	Channel 1	Frequency Range	Below 30MHz
Input Power	DC6V	Detector Function	Quasi-Peak
Environmental Conditions	26.8 deg. C, 36.3% RH	Tested By	Brandon Quan

Antenna Polarity & Test Distance: Loop Antenna Z-Polarity At 3m

No.	Frequency (MHz)	Polarization	Reading QP [dB(uV)]	Factor [dB(1/m)]	Level QP [dB(uV/m)]	Limit QP [dB(uV/m)]	Margin QP [dB]	30m Level [dB(uV/m)]	30m Limit [dB(uV/m)]	30m Margin [dB]	Height (cm)	Angle (Deg)	Pass/Fail
1	0.011	Z	43	51.3	94.3	126.5	32.2	54.3	N/A	N/A	100	355.9	Pass
2	0.46	Z	29.8	19.1	48.9	94.3	45.4	8.9	N/A	N/A	100	28.2	Pass
3	0.54	Z	28.1	17.7	45.8	73	27.2	5.8	N/A	N/A	100	306.7	Pass
4	1.114	Z	23.7	12	35.7	66.7	31	-4.3	N/A	N/A	100	109.9	Pass
5	7.796	Z	5.2	2.6	7.8	69.5	61.7	-32.2	N/A	N/A	100	357.9	Pass
6	13.56	Z	43.5	1.6	45.1	124	78.9	5.1	84	78.9	100	178.5	Pass

REMARKS:

1. Level (dBuV) = Reading (dBuV) + Factor (dB(1/m)).
2. Factor (dB(1/m)) = Antenna Factor(AF) (dB(1/m)) + Cable Loss (dB)
3. Margin value = Emission level – Limit value.
4. All emissions higher than the fundamental are noise floor measurements.

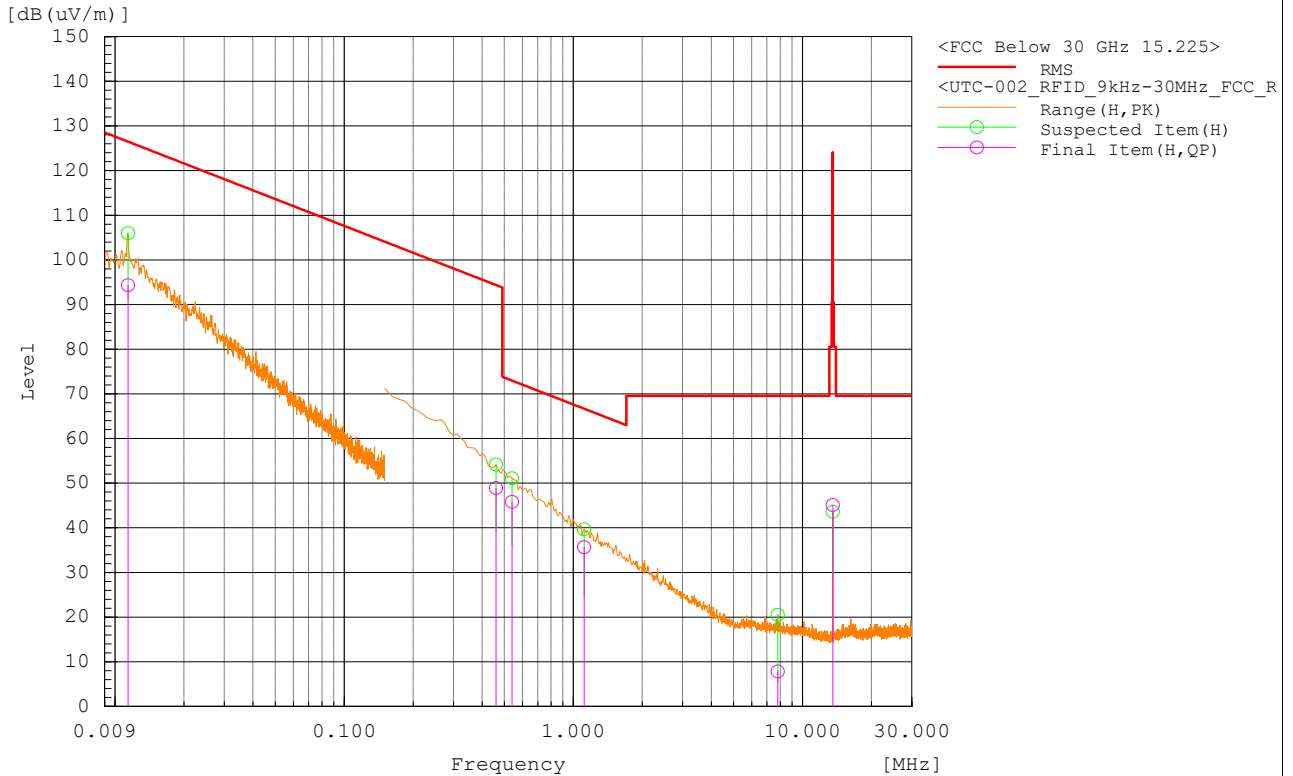

Radiated Emissions (30 MHz~1000 MHz)

EUT Test Condition	01/14/2021		
Channel	Channel 1	Frequency Range	13.56MHz
Input Power	DC 6V	Detector Function	Quasi-Peak
Environmental Conditions	23 deg. C, 30% RH	Tested By	Ellen Chu

No.	Frequency (MHz)	Polarization	Reading QP [dB(uV)]	Factor [dB(1/m)]	Level QP [dB(uV/m)]	Limit\QP dB(uV/m)	Margin QP [dB]	Height (cm)	Angle (Deg)	Pass/Fail
1	36.643	H	-10.3	22.1	11.8	40	-28.2	153	188.1	Pass
2	68.051	H	7.8	13.4	21.2	40	-18.8	100	284.9	Pass
3	108.044	V	-9.9	18.2	8.3	43.5	-35.2	331	0	Pass
4	162.317	V	-9.8	18.9	9.1	43.5	-34.4	294	76.2	Pass
5	297.558	V	-9.6	20.2	10.6	46	-35.4	256	37.1	Pass
6	433.926	H	2.6	23.7	26.3	46	-19.7	143	12.1	Pass

REMARKS:

1. Level (dBuV) = Reading (dBuV) + Factor (dB(1/m)).
2. Factor (dB(1/m)) = Antenna Factor(AF) (dB(1/m)) + Cable Loss (dB)
3. Margin value = Emission level – Limit value.

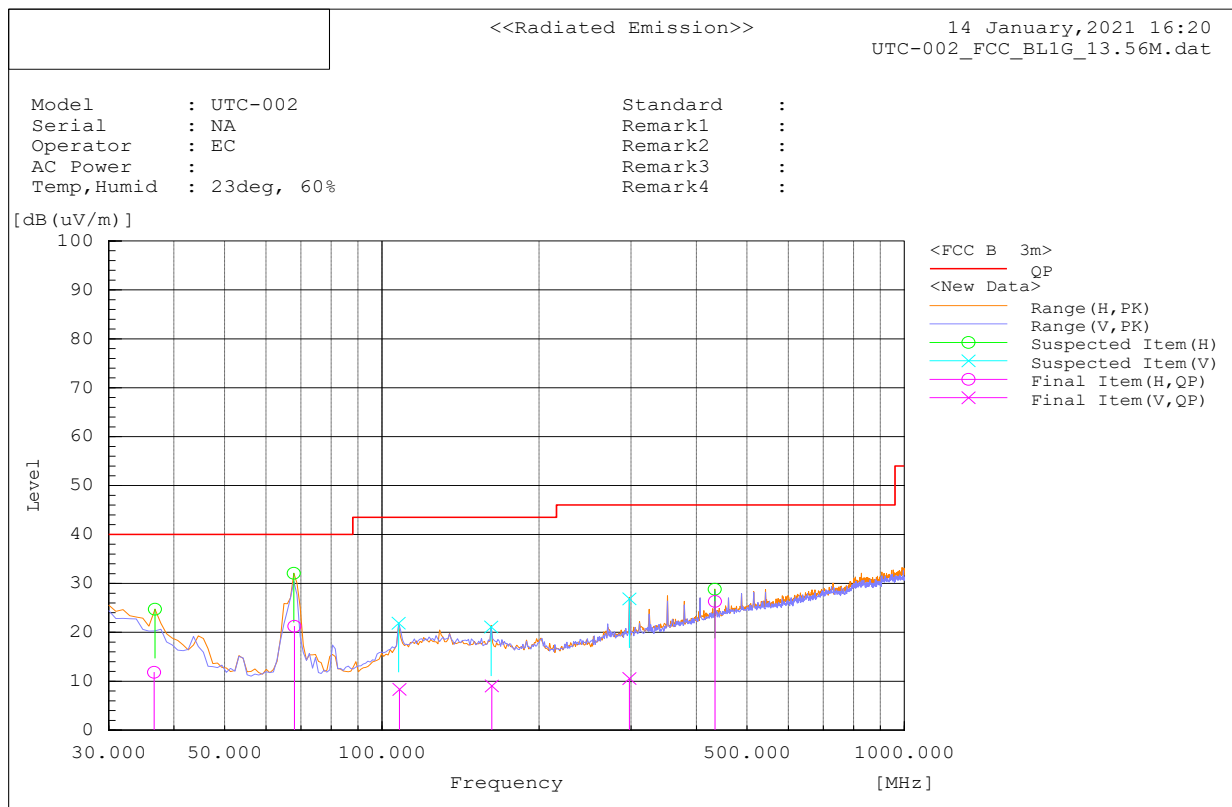

4.2 Conducted Emission Measurement

4.2.1 Limits of Conducted Emission Measurement

Frequency (MHz)	Conducted Limit (dBuV)	
	Quasi-peak	Average
0.15 - 0.5	66 - 56	56 - 46
0.50 - 5.0	56	46
5.0 - 30.0	60	50

- Note: 1. The lower limit shall apply at the transition frequencies.
 2. The limit decreases in line with the logarithm of the frequency in the range of 0.15 to 0.50MHz.

4.2.2 Test Procedures

- The EUT was placed 0.4 meters from the conducting wall of the shielded room with EUT being connected to the power mains through a line impedance stabilization network (LISN). Other support units were connected to the power mains through another LISN. The two LISNs provide 50 ohm/ 50uH of coupling impedance for the measuring instrument.
- Both lines of the power mains connected to the EUT were checked for maximum conducted interference.
- The frequency range from 150 kHz to 30MHz was searched. Emission levels under (Limit - 20dB) was not recorded.

NOTE: The resolution bandwidth and video bandwidth of test receiver is 9 kHz for quasi-peak detection (QP) and average detection (AV) at frequency 0.15MHz-30MHz.

4.2.3 Deviation from Test Standard

No deviation.

4.2.4 Test Setup

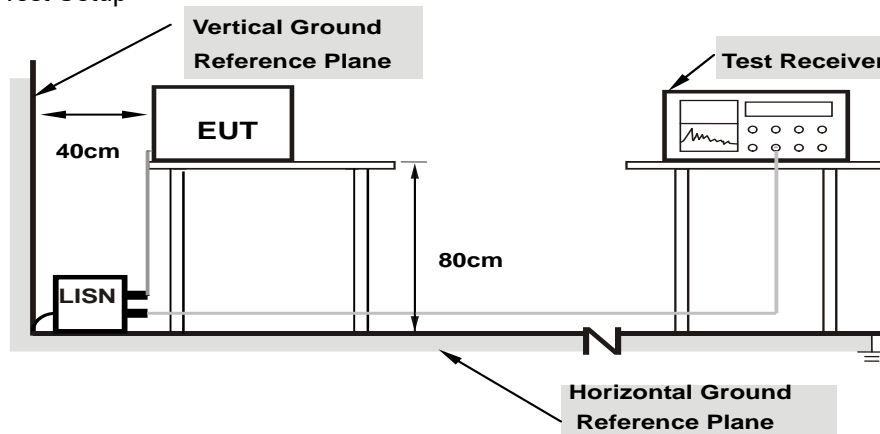

Note: 1. Support units were connected to second LISN.

For the actual test configuration, please refer to the attached file (Test Setup Photo).

4.2.5 EUT Operating Conditions

Same as 4.1.6.

4.2.6 Test Results

N/A (Work with battery).

4.3 Frequency Stability

4.3.1 Limits of Frequency Stability Measurement

The frequency tolerance of the carrier signal shall be maintained within +/- 0.01% of the operating frequency over a temperature variation of -20 degrees to 50 degrees C at normal supply voltage, and for a variation in the primary supply voltage from 85% to 115% of the rated supply voltage at a temperature of 20 degrees C.

4.3.2 Test Setup

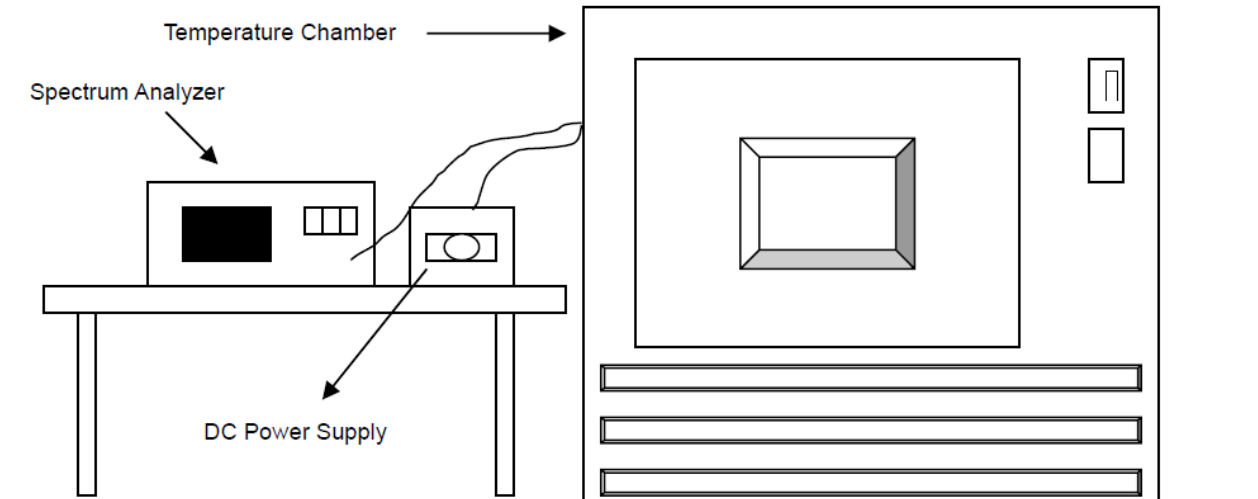

4.3.3 Test Instruments

Refer to section 4.1.2 to get information of above instrument.

4.3.4 Test Procedure

- The EUT was placed inside the environmental test chamber and powered by nominal AC voltage.
- Turned the EUT on and coupled its output to a spectrum analyzer.
- Turned the EUT off and set the chamber to the highest temperature specified.
- Allowed sufficient time (approximately 30 min) for the temperature of the chamber to stabilize then turned the EUT on and measured the operating frequency after 2, 5, and 10 minutes.
- Repeated step 2 and 3 with the temperature chamber set to the lowest temperature.
- The test chamber was allowed to stabilize at +20 degree C for a minimum of 30 minutes. The supply voltage was then adjusted on the EUT from 85% to 115% and the frequency record.

4.3.5 Deviation from Test Standard

No deviation.

4.3.6 EUT Operating Conditions

Same as Item 4.1.6.

4.3.7 Test Result

Frequency Stability Versus Temp.				
TEMP. (□)	Power Supply (Vdc)	Measured Frequency (MHz)	Frequency Dev. (Hz)	Deviation (%)
50	6	13.56002	20	0.000147
40		13.55997	-30	-0.000221
30		13.55997	-30	-0.000221
20		13.56006	60	0.000442
10		13.55994	-60	-0.000442
0		13.56003	30	0.000221
-10		13.55994	-60	-0.000442
-20		13.56005	50	0.000369
20		5.10	13.55992	-80
	6.90	13.55994	-60	-0.000442

4.4 20dB Bandwidth

4.4.1 Limits of 20dB Bandwidth Measurement

The 20dB bandwidth shall be specified in operating frequency band.

4.4.2 Test Setup

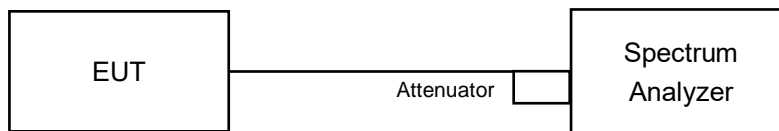

4.4.3 Test Instruments

Refer to section 4.1.2 to get information of above instrument.

4.4.4 Test Procedures

The following procedure shall be used for measuring 99% power bandwidth:

- a) The instrument center frequency is set to the nominal EUT channel center frequency. The frequency span for the spectrum analyzer shall be between 1.5 times and 5.0 times the OBW.
- b) The nominal IF filter bandwidth (3 dB RBW) shall be in the range of 1% to 5% of the OBW, and VBW shall be approximately three times the RBW, unless otherwise specified by the applicable requirement.

The bandwidth of the fundamental frequency was measured by spectrum analyzer with 3KHz RBW and 10KHz VBW. The 20dB bandwidth is defined as the total spectrum the power of which is higher than peak power minus 20dB.

4.4.5 Deviation from Test Standard

Since the transmitter signal is CW-like it is impractical to use a RBW setting of 1–5% of the emission bandwidth since the emission bandwidth will be proportional to the RBW.

4.4.6 EUT Operating Conditions

Same as Item 4.1.6.

4.4.7 Test Results

Frequency (MHz)	20dB Bandwidth (kHz)	99% Bandwidth (kHz)
13.56	3.068	95.776

Test Plots:

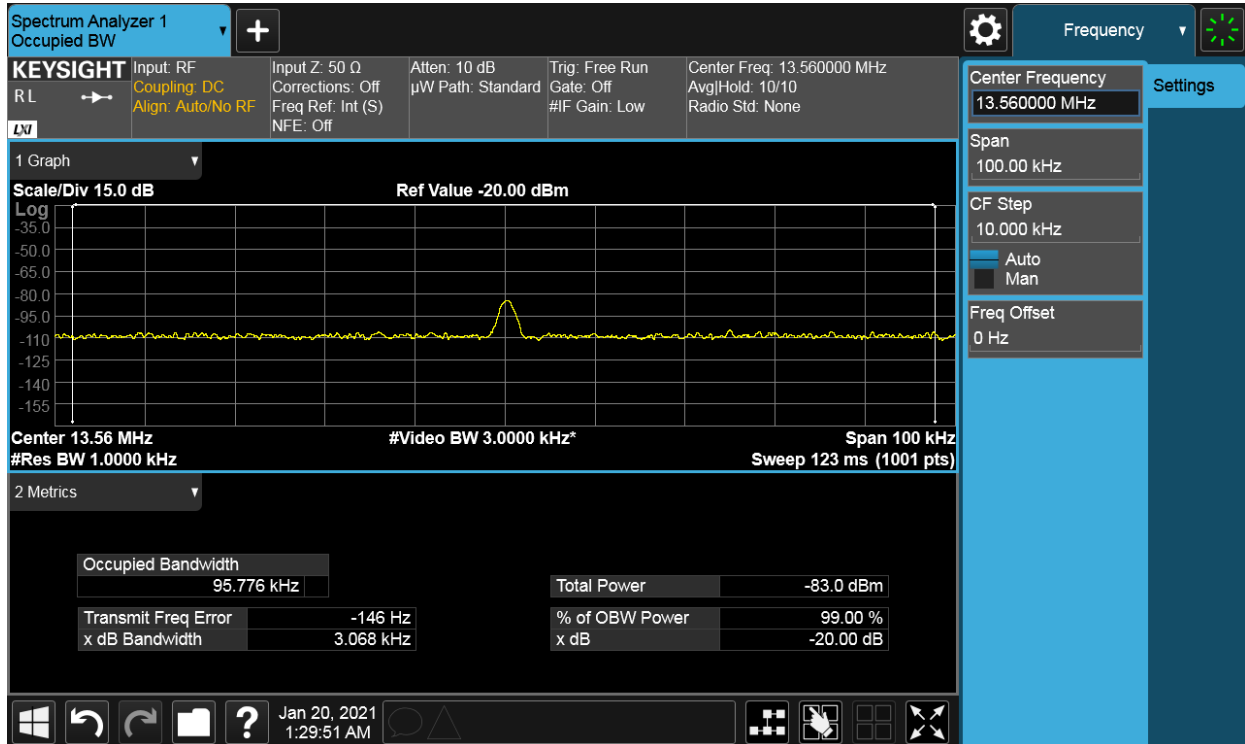

5 Pictures of Test Arrangements

Please see setup photo file.

Appendix – Information on the Testing Laboratories

Bureau Veritas is a global leader in testing, inspection and certification (TIC) services. We help businesses improve safety, sustainability and productivity; and our clients include the majority of leading brands in retail, manufacturing and other industries. With a presence in every major country around the world, our quality assurance and compliance solutions are vital in helping our customers enhance product quality and concept-to-consumer journeys. We also assist with increasing speed to market, profitability and brand equity throughout the supply chain. Bureau Veritas is a leading wireless/IoT testing, inspection, audit and certification provider, with a global network of test laboratories to support the IoT industry in areas of connectivity, security, interoperability as well as quality, health & safety, and environmental/chemical requirements.

If you have any comments, please feel free to contact us at the following:

Milpitas EMC/RF/Safety/Telecom Lab

775 Montague Expressway, Milpitas, CA 95035
Tel: +1 408 526 1188

Sunnyvale OTA/Bluetooth Lab

1293 Anvilwood Avenue, Sunnyvale, CA
94089
Tel: +1 669 600 5293

Littleton EMC/RF/Safety/Environmental Lab

1 Distribution Center Cir #1, Littleton, MA 01460
Tel: +1 978 486 8880

Email: sales.eaw@us.bureauveritas.com

Web Site: www.cpsusa-bureauveritas.com

The address and road map of all our labs can be found in our web site also.

--- END ---