



SPORTON International Inc.

No. 52, Hwa Ya 1st Rd., Kwei-Shan Hsiang, TaoYuan Hsien, Taiwan, R.O.C.
Ph: 886-3-327-3456 / FAX: 886-3-327-0973 / www.sporton.com.tw

FCC RADIO TEST REPORT

Applicant's company	Trapeze Networks, Inc.
Applicant Address	5753 W. Las Positas Blvd., Pleasanton, CA 94588
FCC ID	QZE632
Manufacturer's company	Wistron NeWeb Corporation
Manufacturer Address	No.10-1,Li-hsin Road I,Hsinchu Science Park,Hsinchu 300,Taiwan, R.O.C.

Product Name	802.11abgn outdoor AP
Brand Name	Trapeze
Model Name	MP-632
Test Rule Part(s)	47 CFR FCC Part 15 Subpart E § 15.407
Test Freq. Range	5250 ~ 5350MHz / 5470 ~ 5725MHz
Received Date	Jun. 08, 2009
Final Test Date	Jul. 04, 2009
Submission Type	Class II Change
Operating Mode	Master
Class II Change	Please refer to section 3.7



Statement

Test result included is for the Draft n and 802.11a (5250 ~ 5350MHz / 5470 ~ 5725MHz) of the product.

The test result in this report refers exclusively to the presented test model / sample.

Without written approval of SPORTON International Inc., the test report shall not be reproduced except in full.

The measurements and test results shown in this test report were made in accordance with the procedures and found in compliance with the limit given in ANSI C63.4-2003 and 47 CFR FCC Part 15 Subpart E.

The test equipment used to perform the test is calibrated and traceable to NML/ROC.



Table of Contents

1. CERTIFICATE OF COMPLIANCE	1
2. SUMMARY OF THE TEST RESULT	2
3. GENERAL INFORMATION	3
3.1. Product Details.....	3
3.2. Accessories.....	5
3.3. Table for Filed Antenna.....	6
3.4. Table for Carrier Frequencies	7
3.5. Table for Test Modes	8
3.6. Table for Testing Locations.....	10
3.7. Table for Class II Change	10
3.8. Table for Supporting Units	10
3.9. Table for Parameters of Test Software Setting	11
3.10. Test Configurations	15
4. TEST RESULT	27
4.1. AC Power Line Conducted Emissions Measurement.....	27
4.2. 99% Occupied Bandwidth Measurement	37
4.3. Maximum Conducted Output Power Measurement.....	78
4.4. Power Spectral Density Measurement	193
4.5. Peak Excursion Measurement	239
4.6. Radiated Emissions Measurement	282
4.7. Band Edge Emissions Measurement	430
4.8. Frequency Stability Measurement	455
4.9. Antenna Requirements	460
5. LIST OF MEASURING EQUIPMENTS	461
6. TEST LOCATION.....	463
7. TAF CERTIFICATE OF ACCREDITATION	464
APPENDIX A. PHOTOGRAPHS OF EUT.....	A1 ~ A40
APPENDIX B. TEST PHOTOS.....	B1 ~ B14
APPENDIX C. MAXIMUM PERMISSIBLE EXPOSURE.....	C1 ~ C3



1. CERTIFICATE OF COMPLIANCE

Product Name : 802.11 abgn outdoor AP
Brand Name : Trapeze
Model Name : MP-632
Applicant : Trapeze Networks, Inc.
Test Rule Part(s) : 47 CFR FCC Part 15 Subpart E § 15.407

Sporton International as requested by the applicant to evaluate the EMC performance of the product sample received on Jun. 08, 2009 would like to declare that the tested sample has been evaluated and found to be in compliance with the tested rule parts. The data recorded as well as the test configuration specified is true and accurate for showing the sample's EMC nature.

Jordan Hsiao 2009. 8.19

Jordan Hsiao

SPORTON INTERNATIONAL INC.

2. SUMMARY OF THE TEST RESULT

Applied Standard: 47 CFR FCC Part 15 Subpart E				
Part	Rule Section	Description of Test	Result	Under Limit
4.1	15.207	AC Power Line Conducted Emissions	Complies	15.17 dB
4.2	15.407(a)	26dB Spectrum Bandwidth	Complies	-
4.3	15.407(a)	Maximum Conducted Output Power	Complies	0.01 dB
4.4	15.407(a)	Power Spectral Density	Complies	1.98 dB
4.5	15.407(a)	Peak Excursion	Complies	2.25 dB
4.6	15.407(b)	Radiated Emissions	Complies	3.44 dB
4.7	15.407(b)	Band Edge Emissions	Complies	0.04 dB
4.8	15.407(g)	Frequency Stability	Complies	-
4.9	15.203	Antenna Requirements	Complies	-

Test Items	Uncertainty	Remark
AC Power Line Conducted Emissions	±2.3dB	Confidence levels of 95%
Maximum Conducted Output Power	±0.5dB	Confidence levels of 95%
Power Spectral Density	±0.5dB	Confidence levels of 95%
Peak Excursion	±0.5dB	Confidence levels of 95%
26dB Spectrum Bandwidth / Frequency Stability	±8.5×10 ⁻⁸	Confidence levels of 95%
Radiated Emissions (9kHz~30MHz)	±0.8dB	Confidence levels of 95%
Radiated Emissions (30MHz~1000MHz)	±1.9dB	Confidence levels of 95%
Radiated / Band Edge Emissions (1GHz~18GHz)	±1.9dB	Confidence levels of 95%
Radiated Emissions (18GHz~40GHz)	±1.9dB	Confidence levels of 95%
Temperature	±0.7°C	Confidence levels of 95%
Humidity	±3.2%	Confidence levels of 95%
DC / AC Power Source	±1.4%	Confidence levels of 95%

3. GENERAL INFORMATION

3.1. Product Details

Draft n

Items	Description
Product Type	For Ant. 1, Ant. 2, Ant. 3, Ant. 5: WLAN (3TX, 3RX) For Ant. 4: WLAN (2TX, 2RX)
Radio Type	Intentional Transceiver
Power Type	From POE
Modulation	see the below table for draft n
Data Modulation	OFDM (BPSK / QPSK / 16QAM / 64QAM)
Data Rate (Mbps)	see the below table for Draft n
Frequency Range	5250 ~ 5350MHz / 5470 ~ 5725MHz
Channel Number	15 for 20MHz bandwidth ; 7 for 40MHz bandwidth
Channel Band Width (99%)	MCS0 (20MHz): 17.92 MHz ; MCS0 (40MHz): 36.64 MHz
Conducted Output Power	Band 2: MCS0 (20MHz): 21.76 dBm ; MCS0 (40MHz): 20.71 dBm Band 3: MCS0 (20MHz): 21.01 dBm ; MCS0 (40MHz): 20.39 dBm
Carrier Frequencies	Please refer to section 3.4
Antenna	Please refer to section 3.3

802.11a

Items	Description
Product Type	For Ant. 1, Ant. 2, Ant. 3, Ant. 5: WLAN (3TX, 3RX) For Ant. 4: WLAN (2TX, 2RX)
Radio Type	Intentional Transceiver
Power Type	From POE
Modulation	OFDM for IEEE 802.11a
Data Modulation	OFDM (BPSK / QPSK / 16QAM / 64QAM)
Data Rate (Mbps)	OFDM (6/9/12/18/24/36/48/54)
Frequency Range	5250 ~ 5350MHz / 5470 ~ 5725MHz
Channel Number	15
Channel Band Width (99%)	11a: 17.92 MHz
Conducted Output Power	Band 2: 21.84 dBm ; Band 3: 21.12 dBm
Carrier Frequencies	Please refer to section 3.4
Antenna	Please refer to section 3.3

Antenna & Band width

<For Ant. 1 / Ant. 2 / Ant. 3 / Ant. 5>

Antenna	Single (TX)		Three (TX)	
	20 MHz	40 MHz	20 MHz	40 MHz
802.11a	X	X	V	X
Draft n	X	X	V	V

<For Ant. 4>

Antenna	Single (TX)		Two (TX)	
	20 MHz	40 MHz	20 MHz	40 MHz
802.11a	X	X	V	X
Draft n	X	X	V	V

Draft n spec

MCS Index	Nss	Modulation	R	NBPS	NCBPS		NDBPS		Datarate(Mbps)			
					20MHz	40MHz	20MHz	40MHz	800nsGI		400nsGI	
									20MHz	40MHz	20MHz	40MHz
0	1	BPSK	1/2	1	52	108	26	54	6.5	13.5	7.200	15
1	1	QPSK	1/2	2	104	216	52	108	13.0	27.0	14.400	30
2	1	QPSK	3/4	2	104	216	78	162	19.5	40.5	21.700	45
3	1	16-QAM	1/2	4	208	432	104	216	26.0	54.0	28.900	60
4	1	16-QAM	3/4	4	208	432	156	324	39.0	81.0	43.300	90
5	1	64-QAM	2/3	6	312	648	208	432	52.0	108.0	57.800	120
6	1	64-QAM	3/4	6	312	648	234	486	58.5	121.5	65.000	135
7	1	64-QAM	5/6	6	312	648	260	540	65.0	135.0	72.200	150
8	2	BPSK	1/2	1	104	216	52	108	13.0	27.0	14.444	30
9	2	QPSK	1/2	2	208	432	104	216	26.0	54.0	28.889	60
10	2	QPSK	3/4	2	208	432	156	324	39.0	81.0	43.333	90
11	2	16-QAM	1/2	4	416	864	208	432	52.0	108.0	57.778	120
12	2	16-QAM	3/4	4	416	864	312	648	78.0	162.0	86.667	180
13	2	64-QAM	2/3	6	624	1296	416	864	104.0	216.0	115.556	240
14	2	64-QAM	3/4	6	624	1296	468	972	117.0	243.0	130.000	270
15	2	64-QAM	5/6	6	624	1296	520	1080	130.0	270.0	144.444	300

Symbol	Explanation
NSS	Number of spatial streams
R	Code rate
NBPSC	Number of coded bits per single carrier
NCBPS	Number of coded bits per symbol
NDBPS	Number of data bits per symbol
GI	guard interval

3.2. Accessories

N/A

3.3. Table for Filed Antenna

Ant.	Brand	Model Name	Model Name of User's guide	Antenna Type	Connector	Antenna gain	2.4GHz Band	5GHz Band	# of TX/RX	Final Test
1	MAXRAD	MMO24580608	ANT-7360A-OUT	Omni Antenna	N-Type	5GHz / 8dBi	Yes	Yes	3TX/3RX	Yes
2	Laird	S245112PT	ANT-74520-OUT	Panel Antenna	Reversed-SMA	5GHz / 13.5dBi	Yes	Yes	3TX/3RX	Yes
3	Laird	S24517PT	ANT-77555-OUT	Panel Antenna	Reversed-SMA	5GHz / 10.7dBi	Yes	Yes	3TX/3RX	Yes
4	MARS	MA-WA56-DP25N	ANT-5007-OUT	Panel Antenna	N-Type	5GHz / 23.5dBi	No	Yes	2TX/2RX	Yes
5	TERRAWAVE	T58070MP13620	Alternate for ANT-74520-OUT ANT-77555-OUT	Panel Antenna	RPSMA Plugs	5GHz / 7dBi	No	Yes	3TX/3RX	No

Note:

The EUT has three antenna connectors which can be used for transmitting and receiving simultaneously as 3Tx and 3Rx. Also there are six types of antenna provided to this EUT and all of them can be used as transmitting and receiving antenna.

There are five antennas used for 5GHz Band.

All antennas (connectors) can be used as transmitting/receiving antenna.

Ant. 4 only can be used as outdoor antenna.

Due to the same type of antennas, only antenna with highest gain was chosen for final test.

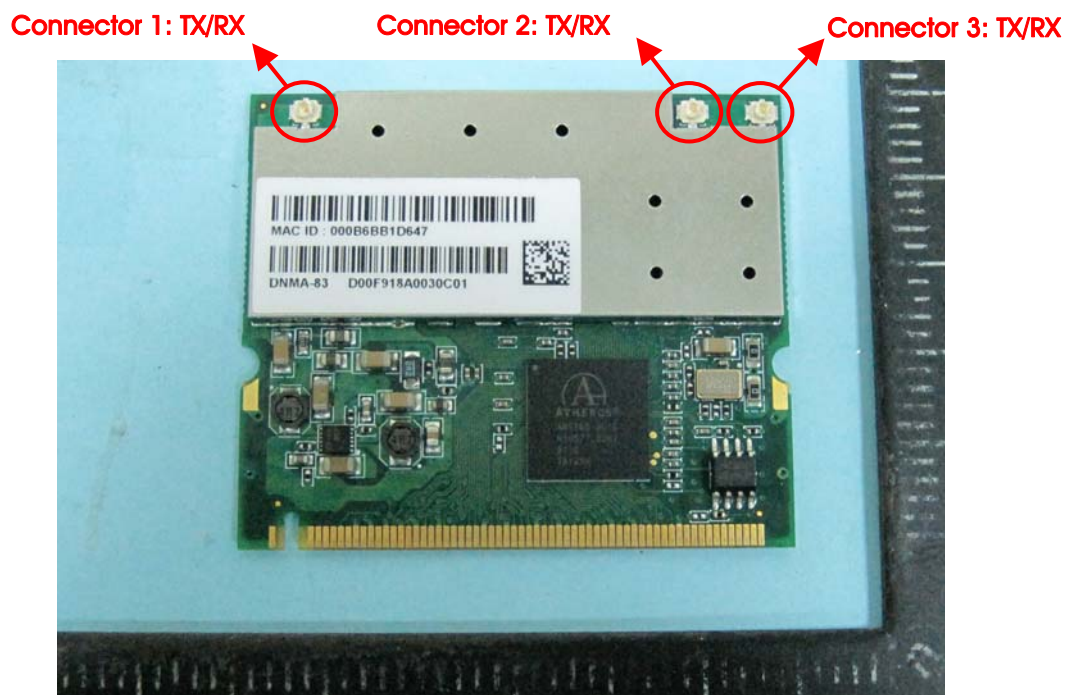

3.4. Table for Carrier Frequencies

Frequency Allocation for 802.11a

There are two bandwidth systems for draft n.

For both 20MHz bandwidth systems, use Channel 52, 56, 60, 64, 100, 104, 108, 112, 116, 120, 124, 128, 132, 136, 140.

For both 40MHz bandwidth systems, use Channel 54, 62, 102, 110, 118, 126, 134.

Frequency Band	Channel No.	Frequency	Channel No.	Frequency
5250~5350 MHz Band 2	52	5260 MHz	60	5300 MHz
	54	5270 MHz	62	5310 MHz
	56	5280 MHz	64	5320 MHz
5470~5725 MHz Band 3	100	5500 MHz	120	5600 MHz
	102	5510MHz	124	5620 MHz
	104	5520 MHz	126	5630 MHz
	108	5540 MHz	128	5640 MHz
	110	5550 MHz	132	5660 MHz
	112	5560 MHz	134	5670 MHz
	116	5580 MHz	136	5680 MHz
	118	5590 MHz	140	5700 MHz

3.5. Table for Test Modes

Preliminary tests were performed in different data rate to find the worst radiated emission. The data rate shown in the table below is the worst-case rate with respect to the specific test item. Investigation has been done on all the possible configurations for searching the worst cases. The following table is a list of the test modes shown in this test report.

<For Ant. 1 / Ant. 2 / Ant. 3>:

Test Items	Mode		Data Rate	Channel	Antenna
AC Power Conducted Emission	Normal Link		Auto	-	-
Max. Conducted Output Power	MCS0/20MHz	Band 2	6.5Mbps	52/60/64	1, 2, 3
		Band 3	6.5Mbps	100/116/140	1, 2, 3
	MCS0/40MHz	Band 2	13.5Mbps	54/62	1, 2, 3
		Band 3	13.5Mbps	102/118/134	1, 2, 3
	11aBPSK	Band 2	6.5Mbps	52/60/64	1, 2, 3
		Band 3	6.5Mbps	100/116/140	1, 2, 3
26dB Spectrum Bandwidth 99% Occupied Bandwidth Measurement Power Spectral Density Peak Excursion	MCS0/20MHz	Band 2	6.5Mbps	52/60/64	1, 2, 3
		Band 3	6.5Mbps	100/116/140	1, 2, 3
	MCS0/40MHz	Band 2	13.5Mbps	54/62	1, 2, 3
		Band 3	13.5Mbps	102/118/134	1, 2, 3
	11aBPSK	Band 2	6.5Mbps	52/60/64	1, 2, 3
		Band 3	6.5Mbps	100/116/140	1, 2, 3
Radiated Emission Below 1GHz	Normal Link		Auto	-	-
Radiated Emission Above 1GHz	MCS0/20MHz	Band 2	6.5Mbps	52/60/64	1, 2, 3
		Band 3	6.5Mbps	100/116/140	1, 2, 3
	MCS0/40MHz	Band 2	13.5Mbps	54/62	1, 2, 3
		Band 3	13.5Mbps	102/118/134	1, 2, 3
	11aBPSK	Band 2	6.5Mbps	52/60/64	1, 2, 3
		Band 3	6.5Mbps	100/116/140	1, 2, 3
Band Edge Emission	MCS0/20MHz	Band 2	6.5Mbps	52/60/64	1, 2, 3
		Band 3	6.5Mbps	100/116/140	1, 2, 3
	MCS0/40MHz	Band 2	13.5Mbps	54/62	1, 2, 3
		Band 3	13.5Mbps	102/118/134	1, 2, 3
	11aBPSK	Band 2	6.5Mbps	52/60/64	1, 2, 3
		Band 3	6.5Mbps s	100/116/140	1, 2, 3
Frequency Stability	Un-modulation		-	60/64	N/A

<For Ant. 4>:

Test Items	Mode		Data Rate	Channel	Antenna
AC Power Conducted Emission	Normal Link		Auto	-	-
Max. Conducted Output Power	MCS0/20MHz	Band 2	6.5Mbps	52/60/64	4
		Band 3	6.5Mbps	100/116/140	4
	MCS0/40MHz	Band 2	13.5Mbps	54/62	4
		Band 3	13.5Mbps	102/118/134	4
	11aBPSK	Band 2	6.5Mbps	52/60/64	4
		Band 3	6.5Mbps	100/116/140	4
26dB Spectrum Bandwidth 99% Occupied Bandwidth Measurement Power Spectral Density Peak Excursion	MCS0/20MHz	Band 2	6.5Mbps	52/60/64	4
		Band 3	6.5Mbps	100/116/140	4
	MCS0/40MHz	Band 2	13.5Mbps	54/62	4
		Band 3	13.5Mbps	102/118/134	4
	11aBPSK	Band 2	6.5Mbps	52/60/64	4
		Band 3	6.5Mbps	100/116/140	4
Radiated Emission Below 1GHz	Normal Link		Auto	-	-
Radiated Emission Above 1GHz	MCS0/20MHz	Band 2	6.5Mbps	52/60/64	4
		Band 3	6.5Mbps	100/116/140	4
	MCS0/40MHz	Band 2	13.5Mbps	54/62	4
		Band 3	13.5Mbps	102/118/134	4
	11aBPSK	Band 2	6.5Mbps	52/60/64	4
		Band 3	6.5Mbps	100/116/140	4
Band Edge Emission	MCS0/20MHz	Band 2	6.5Mbps	52/60/64	4
		Band 3	6.5Mbps	100/116/140	4
	MCS0/40MHz	Band 2	13.5Mbps	54/62	4
		Band 3	13.5Mbps	102/118/134	4
	11aBPSK	Band 2	6.5Mbps	52/60/64	4
		Band 3	6.5Mbps s	100/116/140	4
Frequency Stability	Un-modulation		-	64	N/A

Note: The Ant. 4 only can be used as outdoor antenna.

3.6. Table for Testing Locations

Test Site No.	Site Category	Location	FCC Reg. No.	IC File No.	VCCI Reg. No
03CH03-HY	SAC	Hwa Ya	480872	IC 4088	-
CO04-HY	Conduction	Hwa Ya	480872	IC 4088	-
TH01-HY	OVEN Room	Hwa Ya	-	-	-

Open Area Test Site (OATS); Semi Anechoic Chamber (SAC); Fully Anechoic Chamber (FAC).

Please refer section 6 for Test Site Address.

3.7. Table for Class II Change

This product is an extension of original one reported under Sporton project number: FR961 225AA.

Add 802.11a Band 2 and Band 3 (5250~5350MHz and 5470~5725MHz).

There is no change in hardware or in existing RF relevant portion.

Additional, DFS function testing and evaluation for 5250-5350MHz / 5470-5725MHz MHz band.

3.8. Table for Supporting Units

Support Unit	Brand	Model	FCC ID
POE	Trapeze	XPS-6202-OUT	DoC
Notebook	DELL	M1330	E2KWM3945ABG
Notebook	DELL	D400	E2K24GBRL
Notebook	DELL	D520	E2KWM3945ABG
Mobility Exchange	Trapeze	MX-200R	N/A

3.9. Table for Parameters of Test Software Setting

During testing, Channel & Power Controlling Software provided by the customer was used to control the operating channel as well as the output power level. The RF output power selection is for the setting of RF output power expected by the customer and is going to be fixed on the firmware of the final end product.

<For Antenna 1>:

Power Parameters of Draft n MCS0 20MHz

Test Software Version	TERMINAL					
Frequency	5260 MHz	5300 MHz	5320 MHz	5500 MHz	5580 MHz	5700 MHz
Draft n 20MHz Ant. 1	14	14	11	12	14	12

Power Parameters of Draft n MCS0 40MHz

Test Software Version	TERMINAL				
Frequency	5270 MHz	5310 MHz	5510 MHz	5550 MHz	5670 MHz
Draft n 40MHz Ant. 1	14	10	10	13	12

Power Parameters of IEEE 802.11a

Test Software Version	TERMINAL					
Frequency	5260 MHz	5300 MHz	5320 MHz	5500 MHz	5580 MHz	5700 MHz
IEEE 11a Ant. 1	14	14	12	12	14	12

<For Antenna 2>:

Power Parameters of Draft n MCS0 20MHz

Test Software Version	TERMINAL					
Frequency	5260 MHz	5300 MHz	5320 MHz	5500 MHz	5580 MHz	5700 MHz
Draft n 20MHz Ant. 2	8	8	9	10	9	9

Power Parameters of Draft n MCS0 40MHz

Test Software Version	TERMINAL				
Frequency	5270 MHz	5310 MHz	5510 MHz	5550 MHz	5670 MHz
Draft n 40MHz Ant. 2	9	7	6	8	9

Power Parameters of IEEE 802.11a

Test Software Version	TERMINAL					
Frequency	5260 MHz	5300 MHz	5320 MHz	5500 MHz	5580 MHz	5700 MHz
IEEE 11a Ant. 2	8	8	9	10	9	9

<For Antenna 3>:

Power Parameters of Draft n MCS0 20MHz

Test Software Version	TERMINAL					
Frequency	5260 MHz	5300 MHz	5320 MHz	5500 MHz	5580 MHz	5700 MHz
Draft n 20MHz Ant. 3	11	11	9	10	11	8

Power Parameters of Draft n MCS0 40MHz

Test Software Version	TERMINAL				
Frequency	5270 MHz	5310 MHz	5510 MHz	5550 MHz	5670 MHz
Draft n 40MHz Ant. 3	12	5	8	11	8

Power Parameters of IEEE 802.11a

Test Software Version	TERMINAL					
Frequency	5260 MHz	5300 MHz	5320 MHz	5500 MHz	5580 MHz	5700 MHz
IEEE 11a Ant. 3	11	11	10	11	11	8

<For Antenna 4>:

Power Parameters of Draft n MCS0 20MHz

Test Software Version	TERMINAL					
Frequency	5260 MHz	5300 MHz	5320 MHz	5500 MHz	5580 MHz	5700 MHz
Draft n 20MHz Ant. 4	1	1	1	2	1	1

Power Parameters of Draft n MCS0 40MHz

Test Software Version	TERMINAL				
Frequency	5270 MHz	5310 MHz	5510 MHz	5550 MHz	5670 MHz
Draft n 40MHz Ant. 4	1	1	2	1	1

Power Parameters of IEEE 802.11a

Test Software Version	TERMINAL					
Frequency	5260 MHz	5300 MHz	5320 MHz	5500 MHz	5580 MHz	5700 MHz
IEEE 11a Ant. 4	1	1	1	2	1	1

During the test, the following program under WIN XP was executed:

Executed TERMINAL to control the EUT continuously transmit RF signal.

3.10. Test Configurations

3.10.1. Radiation Emissions Test Configuration

Test Configuration: 9KHz~1GHz

<For Antenna 1>:

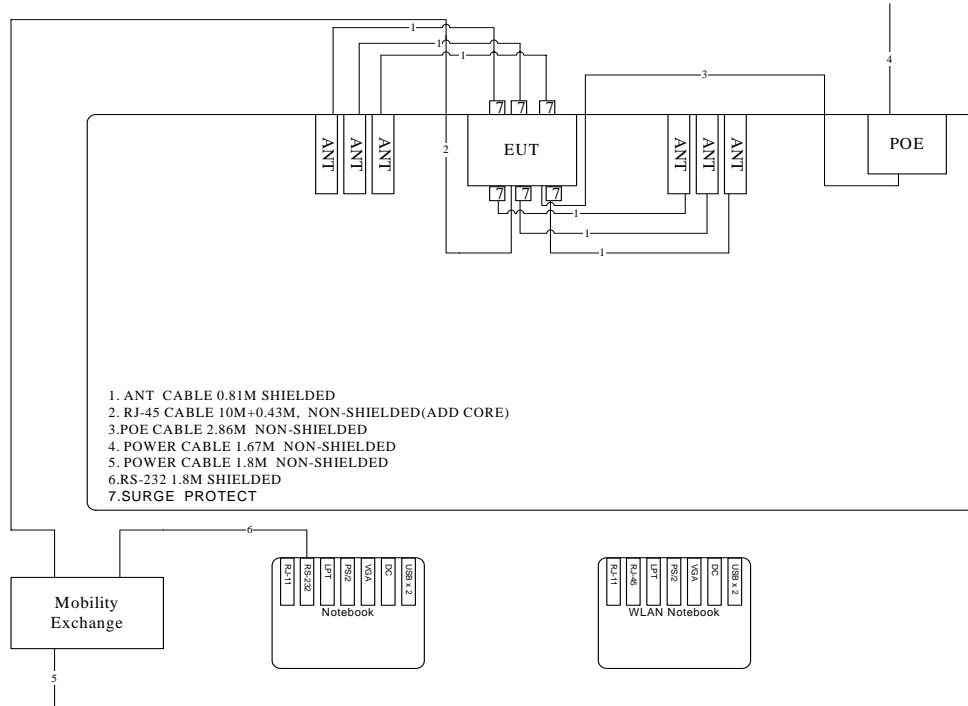

<For Antenna 2>:

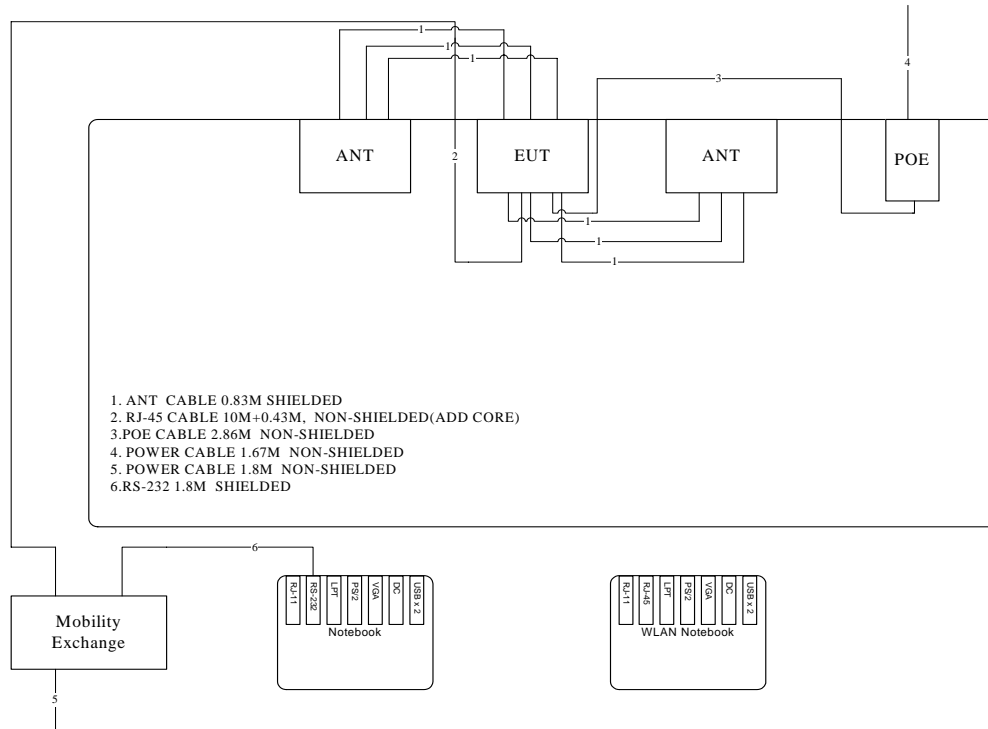

<For Antenna 3>:

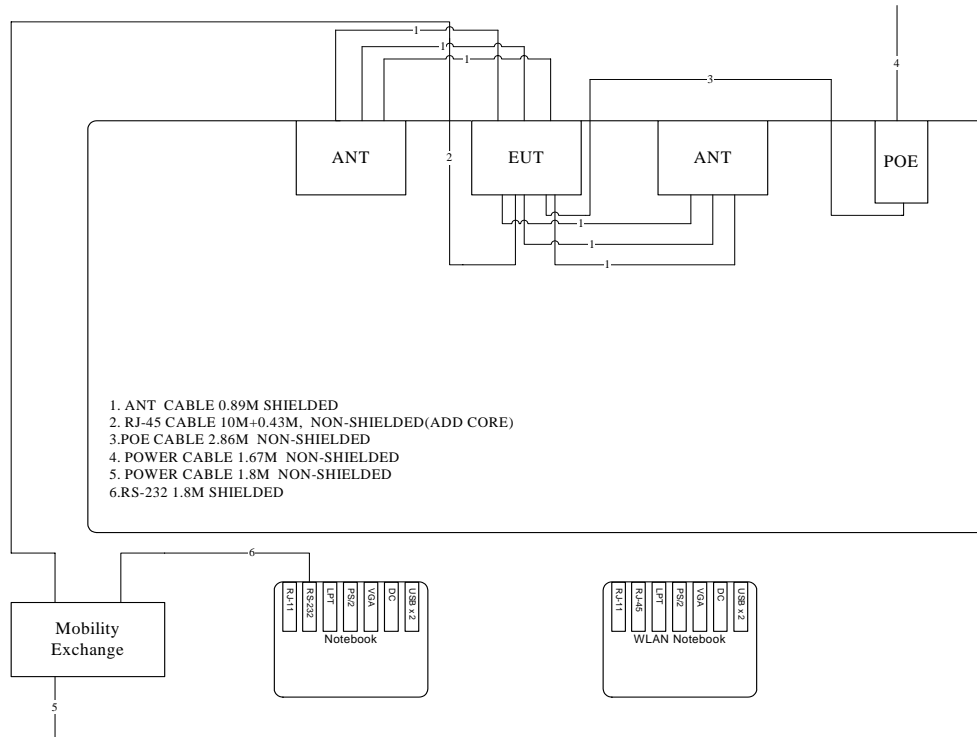

<For Antenna 4>:

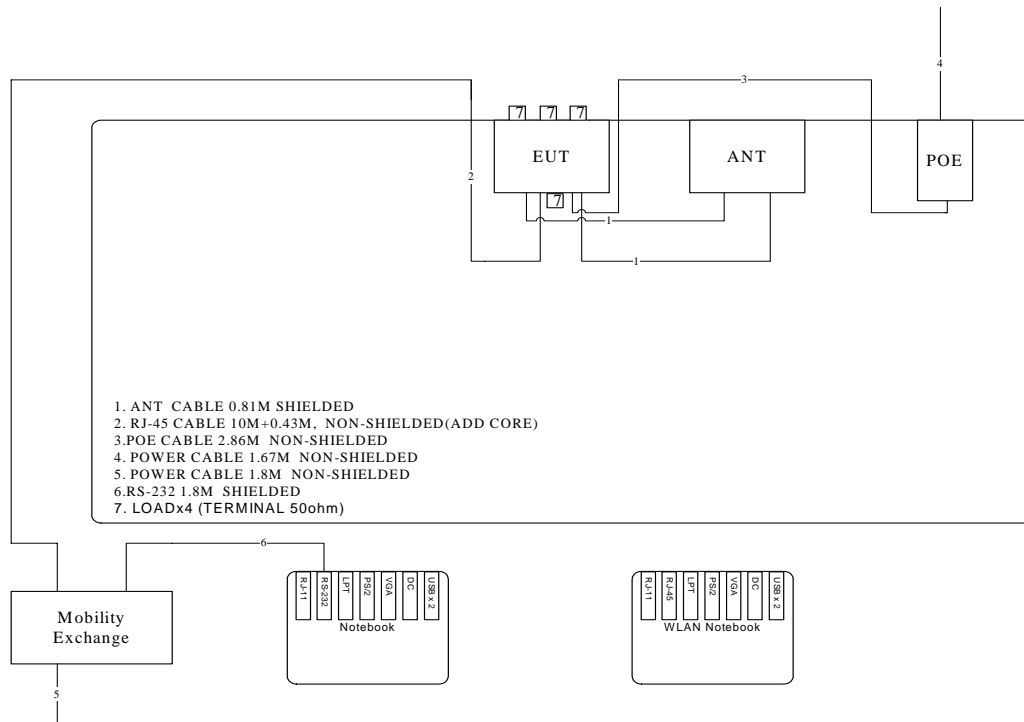

Test Configuration: above 1GHz

<For Antenna 1>:

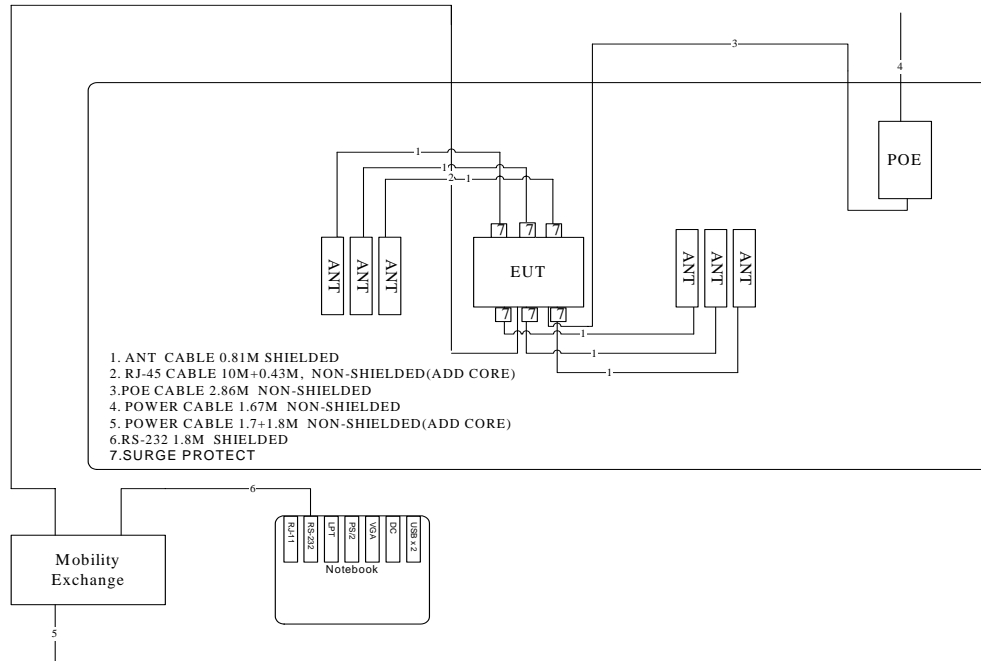

<For Antenna 2>:

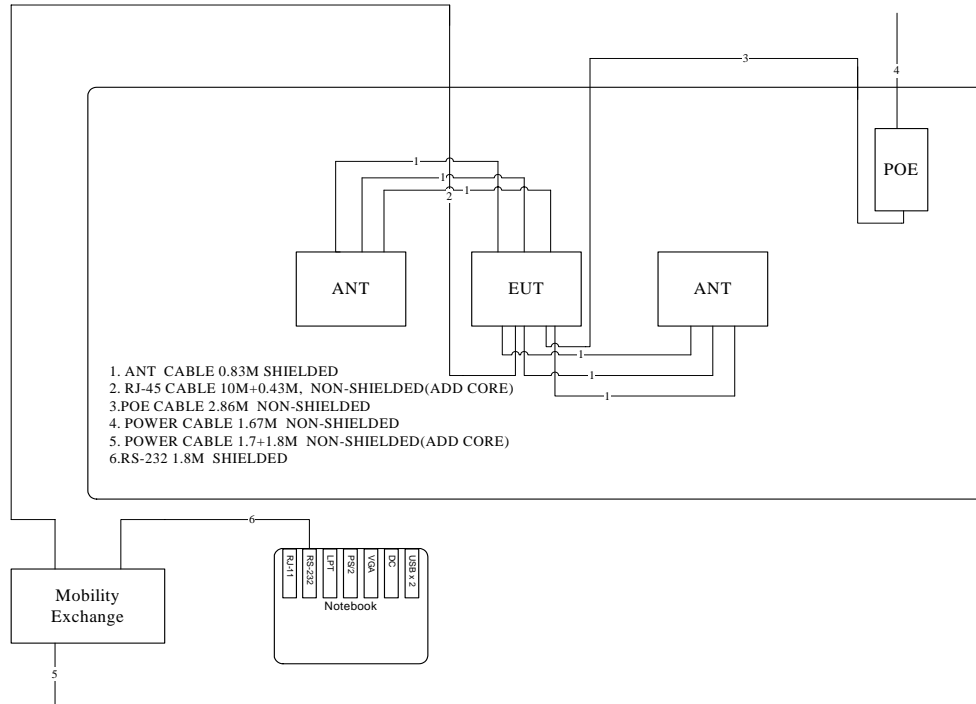

<For Antenna 3>:

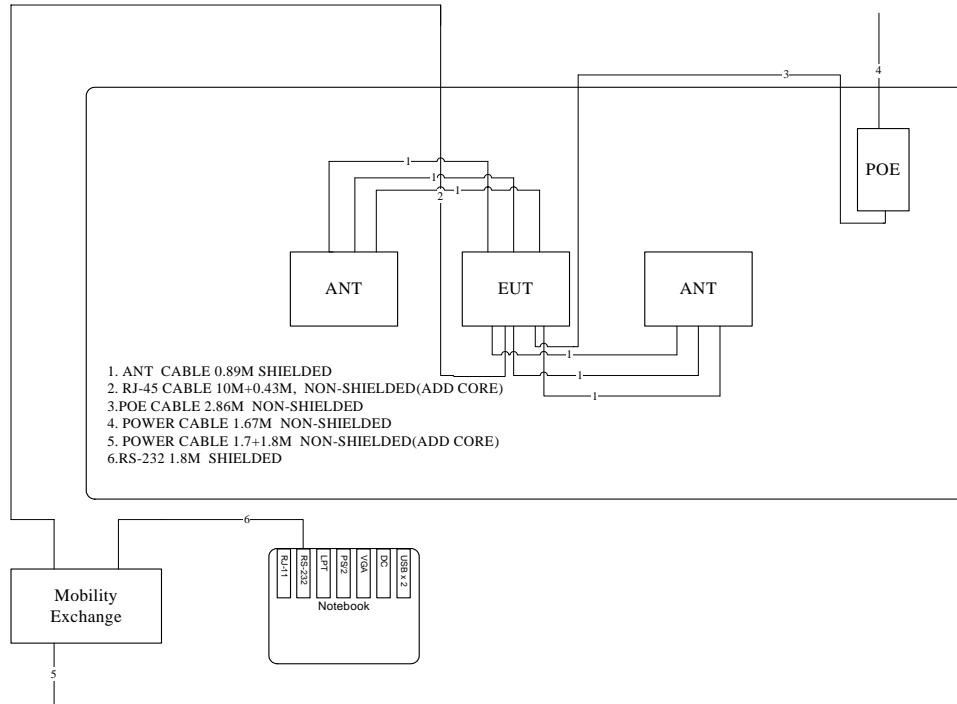

<For Antenna 4>:

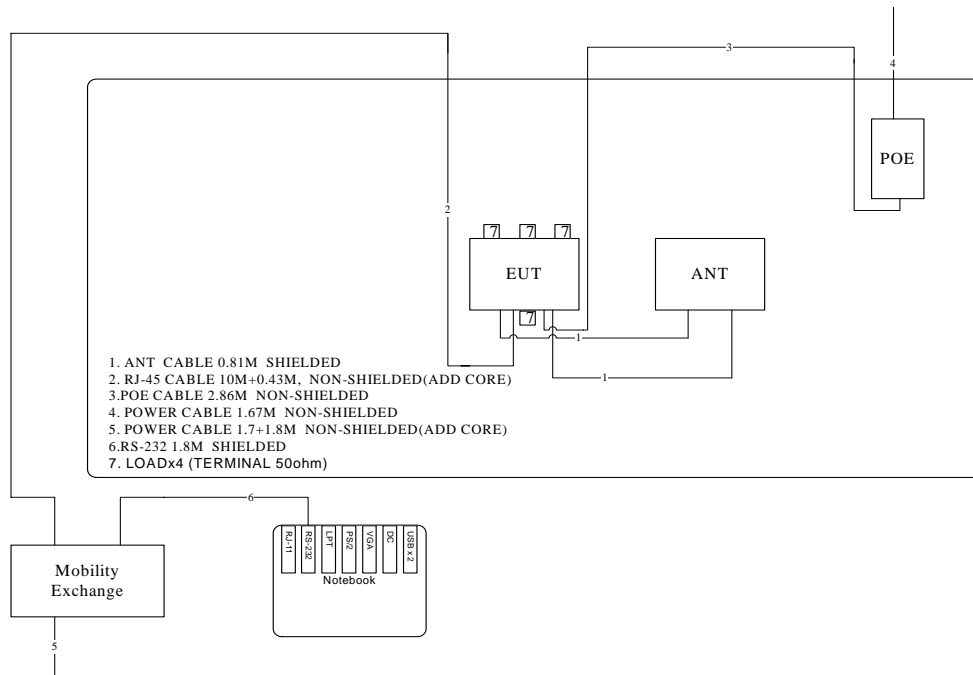

3.10.2. AC Power Line Conduction Emissions Test Configuration

<For Antenna 1 >:

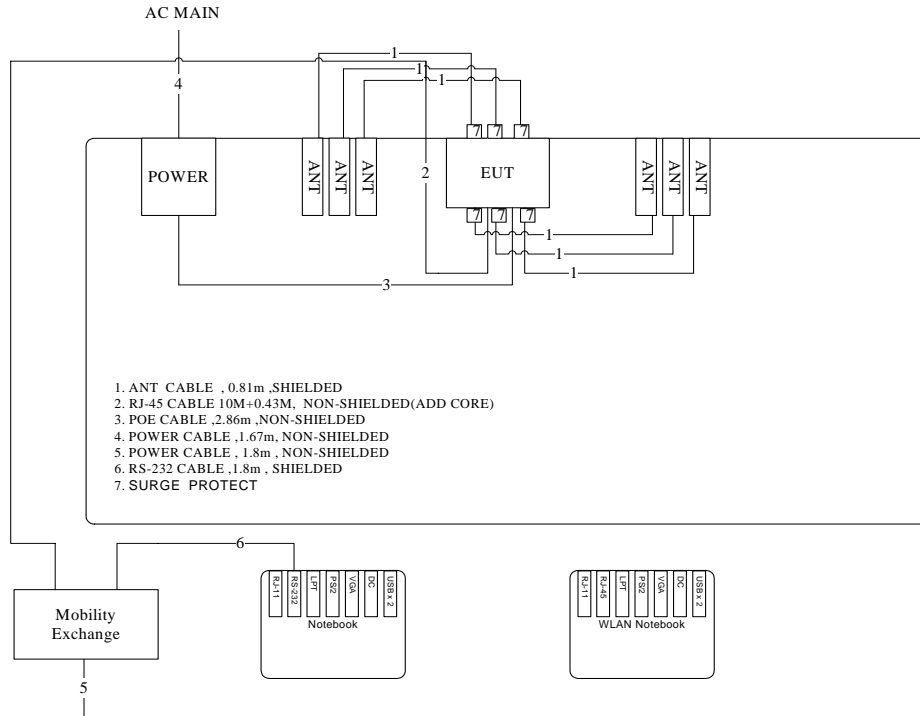

<For Antenna 2>:

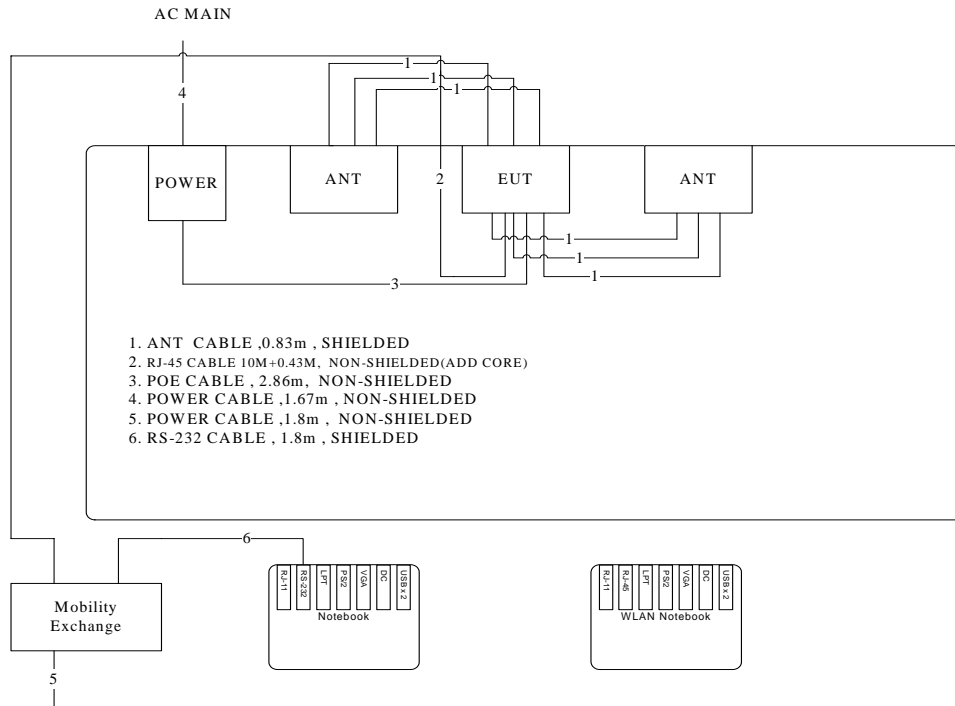

<For Antenna 3>:

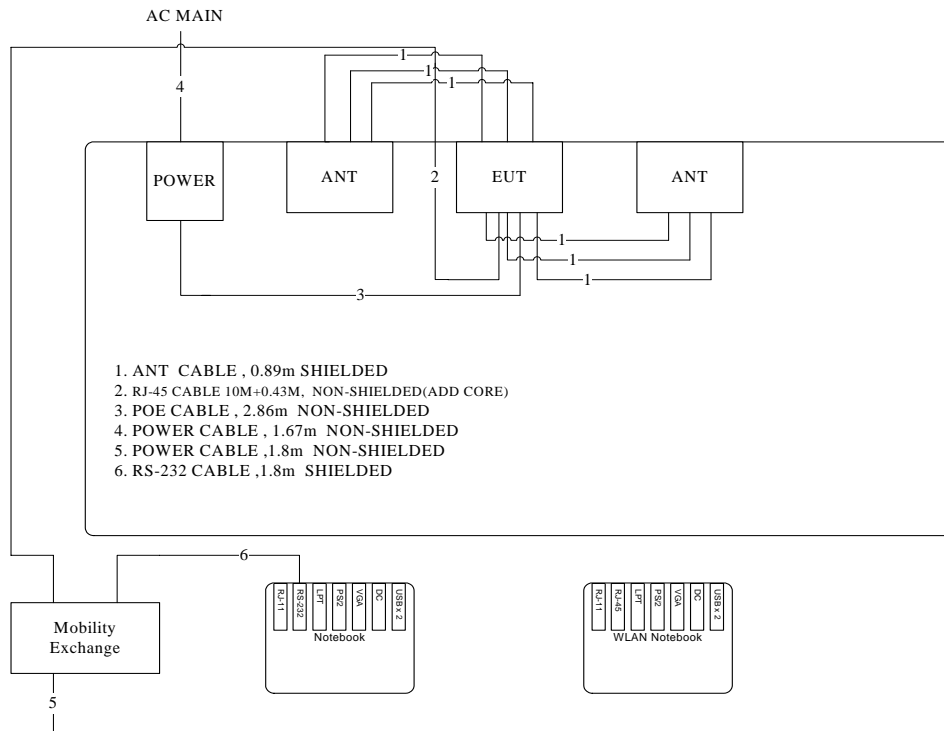

<For Antenna 4>:

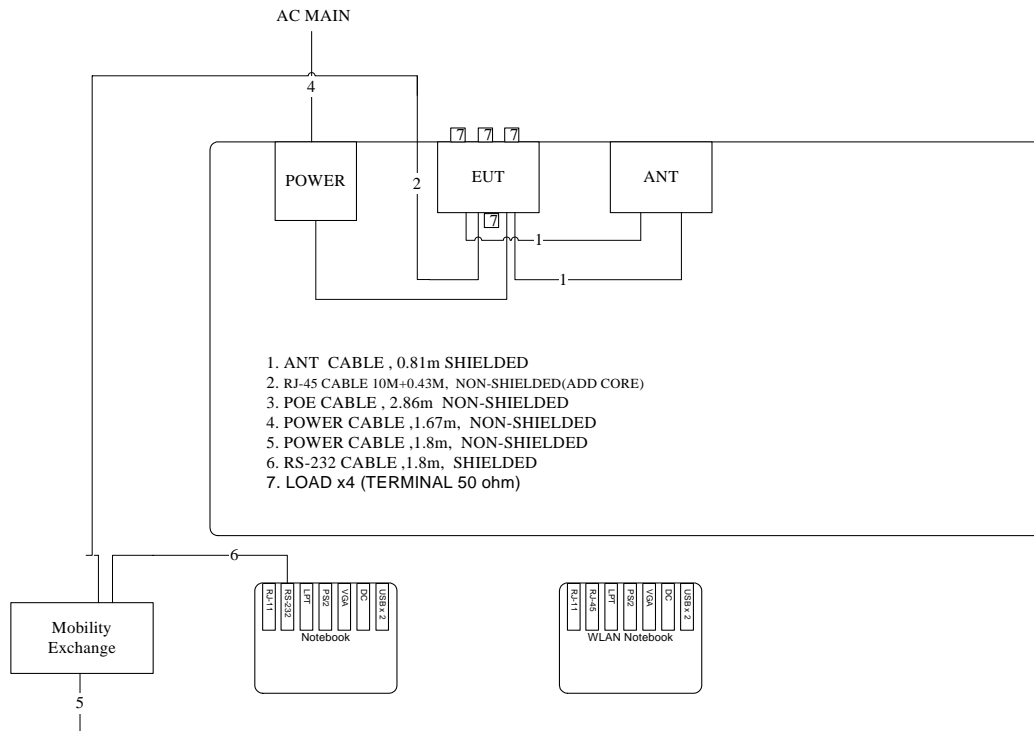

4. TEST RESULT

4.1. AC Power Line Conducted Emissions Measurement

4.1.1. Limit

For this product that is designed to connect to the AC power line, the radio frequency voltage that is conducted back onto the AC power line on any frequency or frequencies within the band 150 kHz to 30 MHz shall not exceed below limits table.

Frequency (MHz)	QP Limit (dBuV)	AV Limit (dBuV)
0.15~0.5	66~56	56~46
0.5~5	56	46
5~30	60	50

4.1.2. Measuring Instruments and Setting

Please refer to section 5 of equipments list in this report. The following table is the setting of the receiver.

Receiver Parameters	Setting
Attenuation	10 dB
Start Frequency	0.15 MHz
Stop Frequency	30 MHz
IF Bandwidth	9 KHz

4.1.3. Test Procedures

1. Configure the EUT according to ANSI C63.4. The EUT or host of EUT has to be placed 0.4 meter far from the conducting wall of the shielding room and at least 80 centimeters from any other grounded conducting surface.
2. Connect EUT or host of EUT to the power mains through a line impedance stabilization network (LISN).
3. All the support units are connected to the other LISNs. The LISN should provide 50uH/50ohms coupling impedance.
4. The frequency range from 150 KHz to 30 MHz was searched.
5. Set the test-receiver system to Peak Detect Function and Specified Bandwidth with Maximum Hold Mode.
6. The measurement has to be done between each power line and ground at the power terminal.

4.1.6. EUT Operation during Test

The EUT was placed on the test table and programmed in normal function.

4.1.7. Results of AC Power Line Conducted Emissions Measurement

<For Antenna 1>:

Temperature	24.1°C	Humidity	53.4%
Test Engineer	Aric Li	Phase	Line
Configuration	Normal Link		

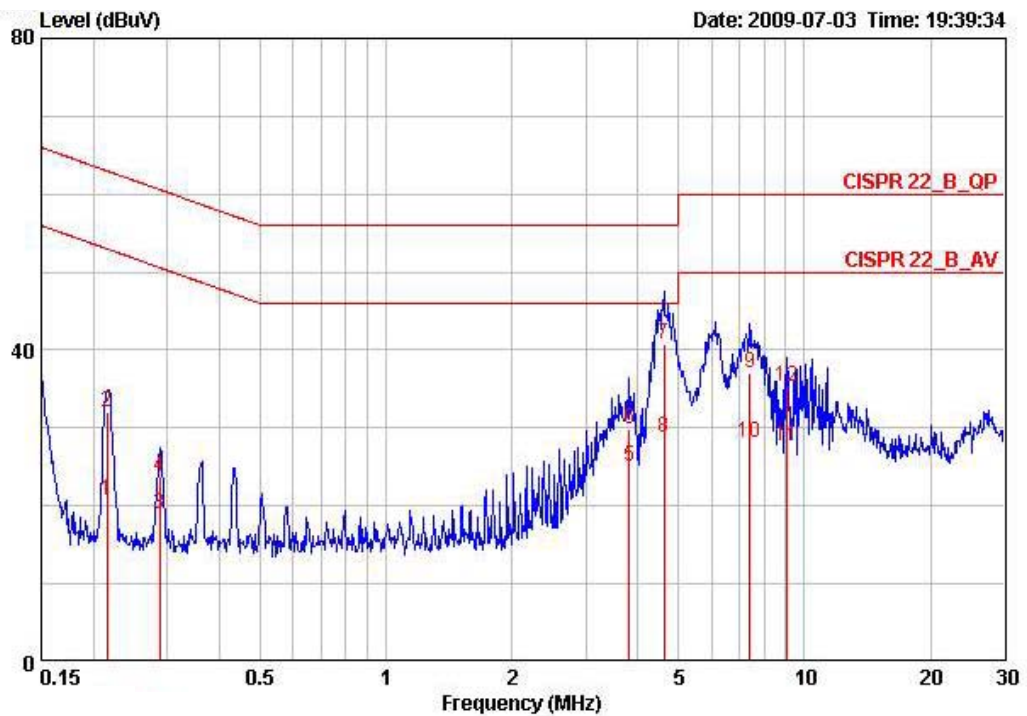

	Freq	Level	Over Limit	Limit Line	Read Level	LISN Factor	Cable Loss	Remark
	MHz	dBuV	dB	dBuV	dBuV	dB	dB	
1	0.21506	20.63	-32.38	53.01	20.38	0.05	0.20	AVERAGE
2	0.21506	31.98	-31.03	63.01	31.73	0.05	0.20	QP
3	0.28782	18.89	-31.70	50.59	18.65	0.04	0.20	AVERAGE
4	0.28782	23.80	-36.79	60.59	23.56	0.04	0.20	QP
5	3.820	25.12	-20.88	46.00	24.72	0.10	0.30	AVERAGE
6	3.820	29.97	-26.03	56.00	29.57	0.10	0.30	QP
7	4.622	40.83	-15.17	56.00	40.39	0.14	0.30	QP
8	4.622	28.72	-17.28	46.00	28.28	0.14	0.30	AVERAGE
9	7.407	36.96	-23.04	60.00	36.31	0.27	0.38	QP
10	7.407	28.19	-21.81	50.00	27.54	0.27	0.38	AVERAGE
11	9.085	27.61	-22.39	50.00	26.99	0.32	0.30	AVERAGE
12	9.085	35.21	-24.79	60.00	34.59	0.32	0.30	QP

Temperature	24.1°C	Humidity	53.4%
Test Engineer	Aric Li	Phase	Neutral
Configuration	Normal Link		

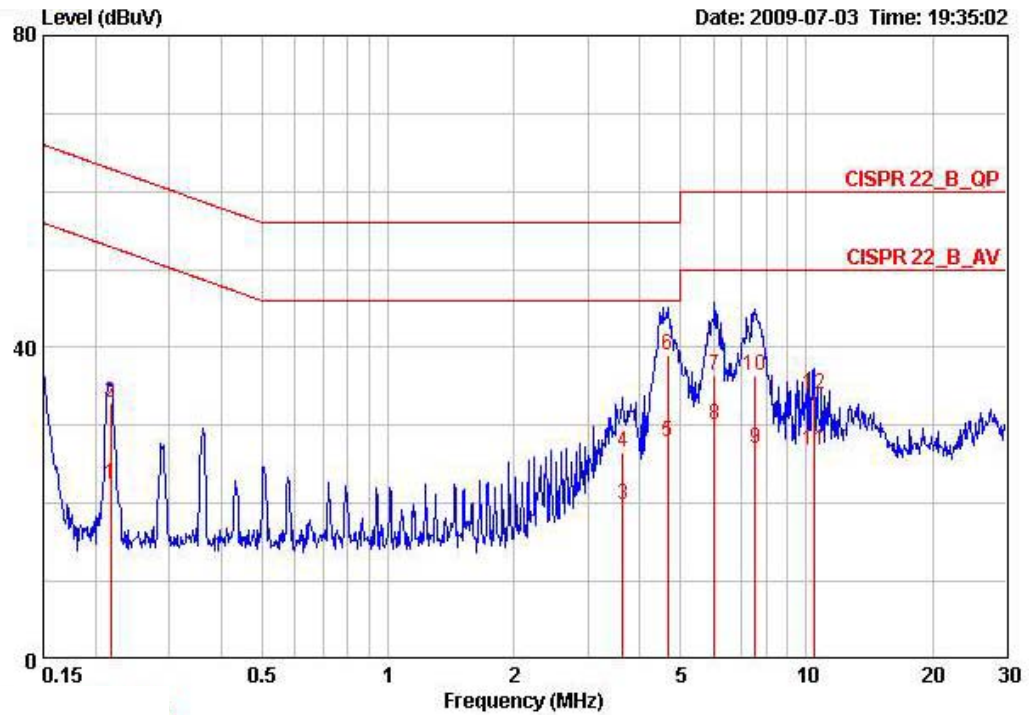

	Freq	Level	Over Limit	Limit Line	Read Level	LISN Factor	Cable Loss	Remark
	MHz	dBuV	dB	dBuV	dBuV	dB	dB	
1	0.21735	22.51	-30.41	52.92	22.23	0.08	0.20	AVERAGE
2	0.21735	33.02	-29.90	62.92	32.74	0.08	0.20	QP
3	3.642	19.80	-26.20	46.00	19.37	0.13	0.30	AVERAGE
4	3.642	26.52	-29.48	56.00	26.09	0.13	0.30	QP
5	4.672	27.90	-18.10	46.00	27.42	0.18	0.30	AVERAGE
6	4.672	39.04	-16.96	56.00	38.56	0.18	0.30	QP
7	6.024	36.31	-23.69	60.00	35.75	0.25	0.31	QP
8	6.024	30.18	-19.82	50.00	29.62	0.25	0.31	AVERAGE
9	7.526	26.95	-23.05	50.00	26.24	0.31	0.40	AVERAGE
10	7.526	36.48	-23.52	60.00	35.77	0.31	0.40	QP
11	10.452	26.87	-23.13	50.00	26.07	0.41	0.39	AVERAGE
12	10.452	34.06	-25.94	60.00	33.26	0.41	0.39	QP

Note:

Level = Read Level + LISN Factor + Cable Loss

<For Antenna 2>:

Temperature	24.1°C	Humidity	53.4%
Test Engineer	Aric Li	Phase	Line
Configuration	Normal Link		

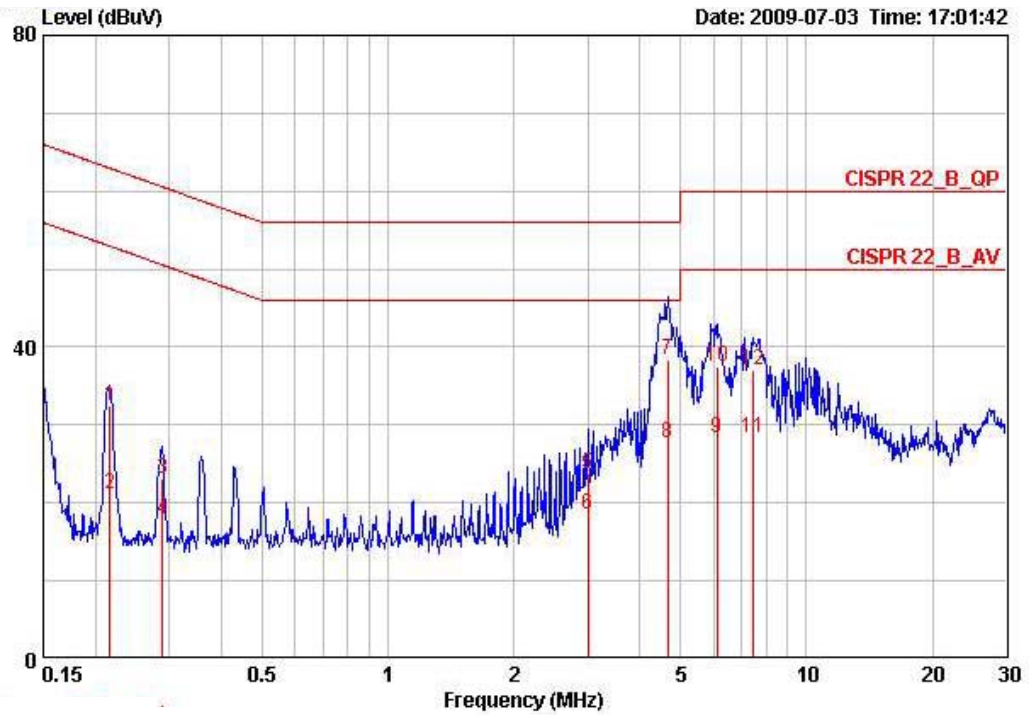

	Freq	Level	Over Limit	Limit Line	Read Level	LISN Factor	Cable Loss	Remark
	MHz	dBuV	dB	dBuV	dBuV	dB	dB	
1	0.21620	32.57	-30.40	62.96	32.32	0.05	0.20	QP
2	0.21620	21.25	-31.72	52.96	21.00	0.05	0.20	AVERAGE
3	0.28935	23.05	-37.49	60.54	22.81	0.04	0.20	QP
4	0.28935	17.91	-32.63	50.54	17.67	0.04	0.20	AVERAGE
5	3.009	23.81	-32.19	56.00	23.53	0.08	0.20	QP
6	3.009	18.48	-27.52	46.00	18.20	0.08	0.20	AVERAGE
7	4.672	38.46	-17.54	56.00	38.02	0.14	0.30	QP
8	4.672	27.61	-18.39	46.00	27.17	0.14	0.30	AVERAGE
9	6.121	28.24	-21.76	50.00	27.70	0.22	0.33	AVERAGE
10	6.121	37.46	-22.54	60.00	36.92	0.22	0.33	QP
11	7.446	28.27	-21.73	50.00	27.61	0.27	0.39	AVERAGE
12	7.446	37.00	-23.00	60.00	36.34	0.27	0.39	QP

Temperature	24.1°C	Humidity	53.4%
Test Engineer	Aric Li	Phase	Neutral
Configuration	Normal Link		

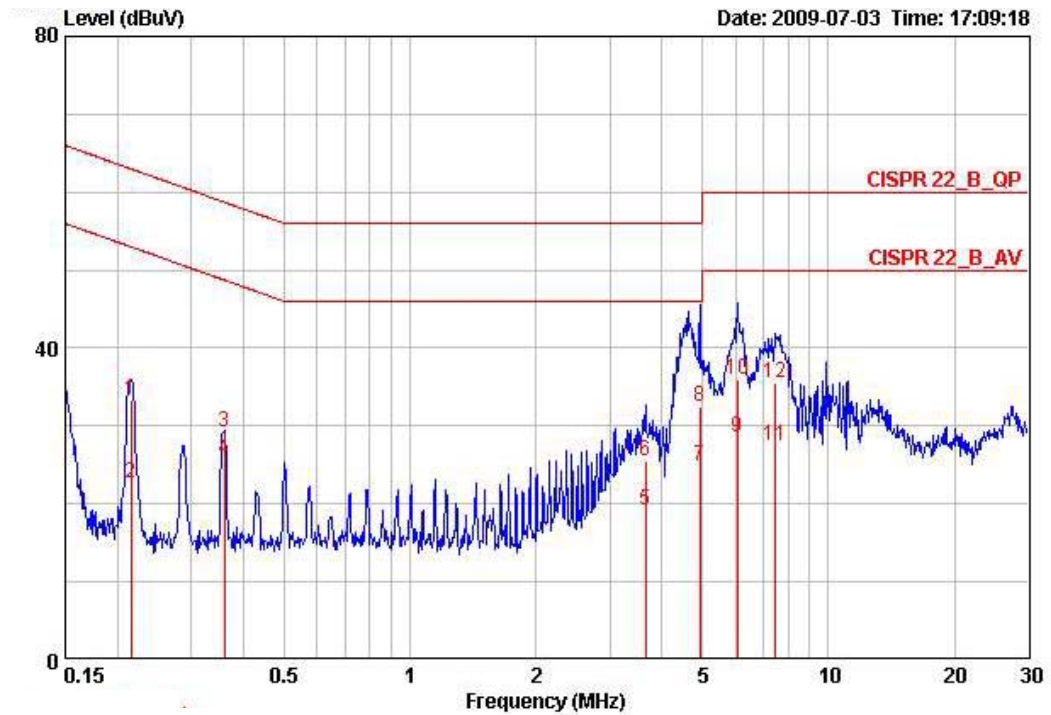

	Freq	Level	Over	Limit	Read	LISN	Cable	Remark
	MHz	dBuV	Limit	Line	Level	Factor	Loss	
			dB	dBuV	dBuV	dB	dB	
1	0.21506	33.46	-29.55	63.01	33.18	0.08	0.20	QP
2	0.21506	22.77	-30.24	53.01	22.49	0.08	0.20	AVERAGE
3	0.35955	29.21	-29.53	58.74	28.94	0.07	0.20	QP
4	0.35955	25.75	-22.99	48.74	25.48	0.07	0.20	AVERAGE
5	3.661	19.17	-26.83	46.00	18.74	0.13	0.30	AVERAGE
6	3.661	25.59	-30.41	56.00	25.16	0.13	0.30	QP
7	4.926	24.89	-21.11	46.00	24.39	0.20	0.30	AVERAGE
8	4.926	32.43	-23.57	56.00	31.93	0.20	0.30	QP
9	6.056	28.64	-21.36	50.00	28.07	0.25	0.31	AVERAGE
10	6.056	35.95	-24.05	60.00	35.38	0.25	0.31	QP
11	7.486	27.56	-22.44	50.00	26.85	0.31	0.40	AVERAGE
12	7.486	35.54	-24.46	60.00	34.83	0.31	0.40	QP

Note:

$$\text{Level} = \text{Read Level} + \text{LISN Factor} + \text{Cable Loss}$$

<For Antenna 3>:

Temperature	24.1°C	Humidity	53.4%
Test Engineer	Aric Li	Phase	Line
Configuration	Normal Link		

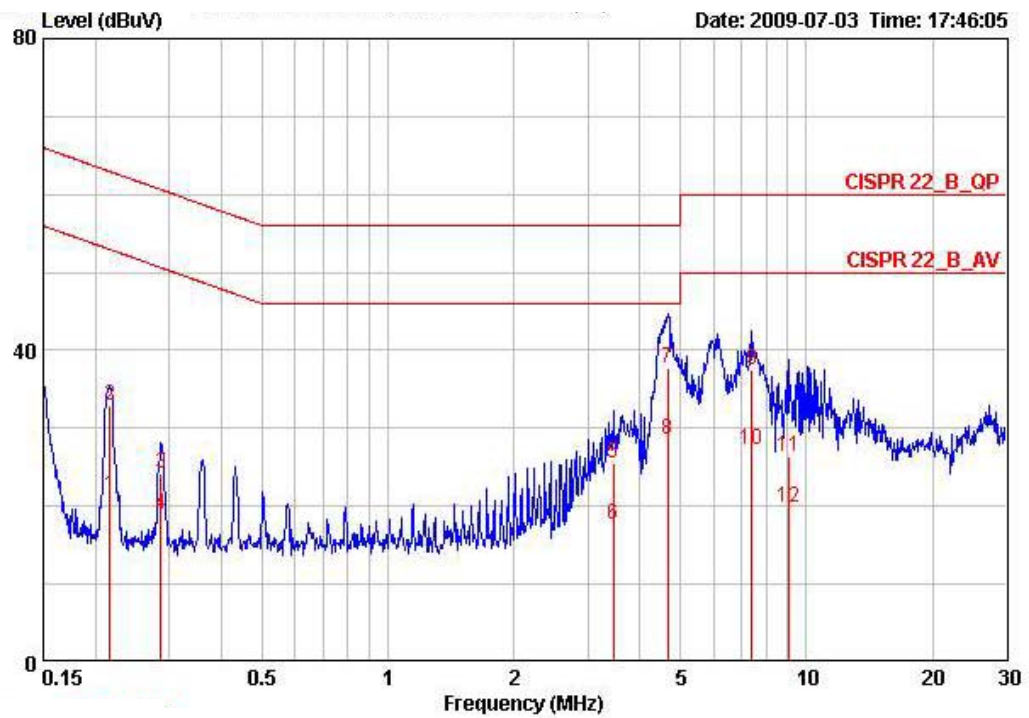

	Freq	Level	Over Limit	Limit Line	Read Level	LISN Factor	Cable Loss	Remark
	MHz	dBuV	dB	dBuV	dBuV	dB	dB	
1	0.21620	21.45	-31.52	52.96	21.20	0.05	0.20	AVERAGE
2	0.21620	32.83	-30.14	62.96	32.58	0.05	0.20	QP
3	0.28630	24.25	-36.38	60.63	24.01	0.04	0.20	QP
4	0.28630	18.96	-31.67	50.63	18.72	0.04	0.20	AVERAGE
5	3.454	25.61	-30.39	56.00	25.23	0.09	0.29	QP
6	3.454	17.67	-28.33	46.00	17.29	0.09	0.29	AVERAGE
7	4.672	37.75	-18.25	56.00	37.31	0.14	0.30	QP
8	4.672	28.48	-17.52	46.00	28.04	0.14	0.30	AVERAGE
9	7.407	37.49	-22.51	60.00	36.84	0.27	0.38	QP
10	7.407	27.33	-22.67	50.00	26.68	0.27	0.38	AVERAGE
11	9.059	26.35	-33.65	60.00	25.73	0.32	0.30	QP
12	9.059	19.79	-30.21	50.00	19.17	0.32	0.30	AVERAGE

Temperature	24.1°C	Humidity	53.4%
Test Engineer	Aric Li	Phase	Neutral
Configuration	Normal Link		

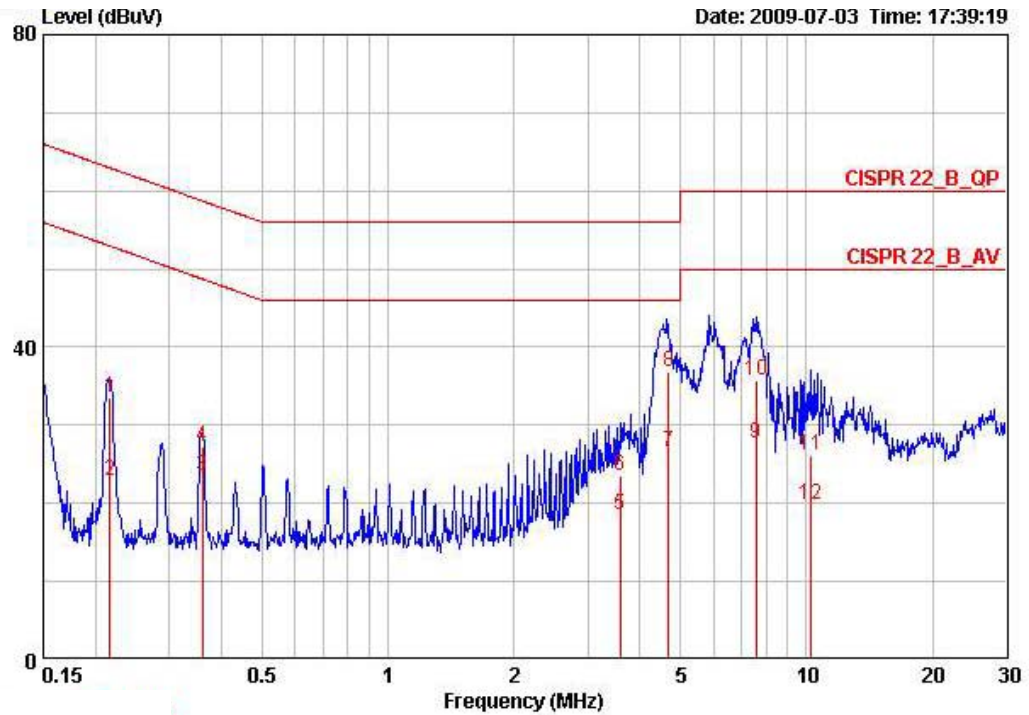

	Freq	Level	Over Limit	Limit Line	Read Level	LISN Factor	Cable Loss	Remark
	MHz	dBuV	dB	dBuV	dBuV	dB	dB	
1	0.21620	33.52	-29.44	62.96	33.24	0.08	0.20	QP
2	0.21620	22.85	-30.11	52.96	22.57	0.08	0.20	AVERAGE
3	0.35955	23.47	-25.27	48.74	23.20	0.07	0.20	AVERAGE
4	0.35955	27.31	-31.43	58.74	27.04	0.07	0.20	QP
5	3.584	18.60	-27.40	46.00	18.17	0.13	0.30	AVERAGE
6	3.584	23.55	-32.45	56.00	23.12	0.13	0.30	QP
7	4.681	26.61	-19.39	46.00	26.13	0.18	0.30	AVERAGE
8	4.681	36.77	-19.23	56.00	36.29	0.18	0.30	QP
9	7.566	27.62	-22.38	50.00	26.91	0.31	0.40	AVERAGE
10	7.566	35.73	-24.27	60.00	35.02	0.31	0.40	QP
11	10.288	26.13	-33.87	60.00	25.37	0.40	0.36	QP
12	10.288	19.75	-30.25	50.00	18.99	0.40	0.36	AVERAGE

Note:

$$\text{Level} = \text{Read Level} + \text{LISN Factor} + \text{Cable Loss}$$

<For Antenna 4>:

Temperature	24.1°C	Humidity	53.4%
Test Engineer	Aric Li	Phase	Line
Configuration	Normal Link		

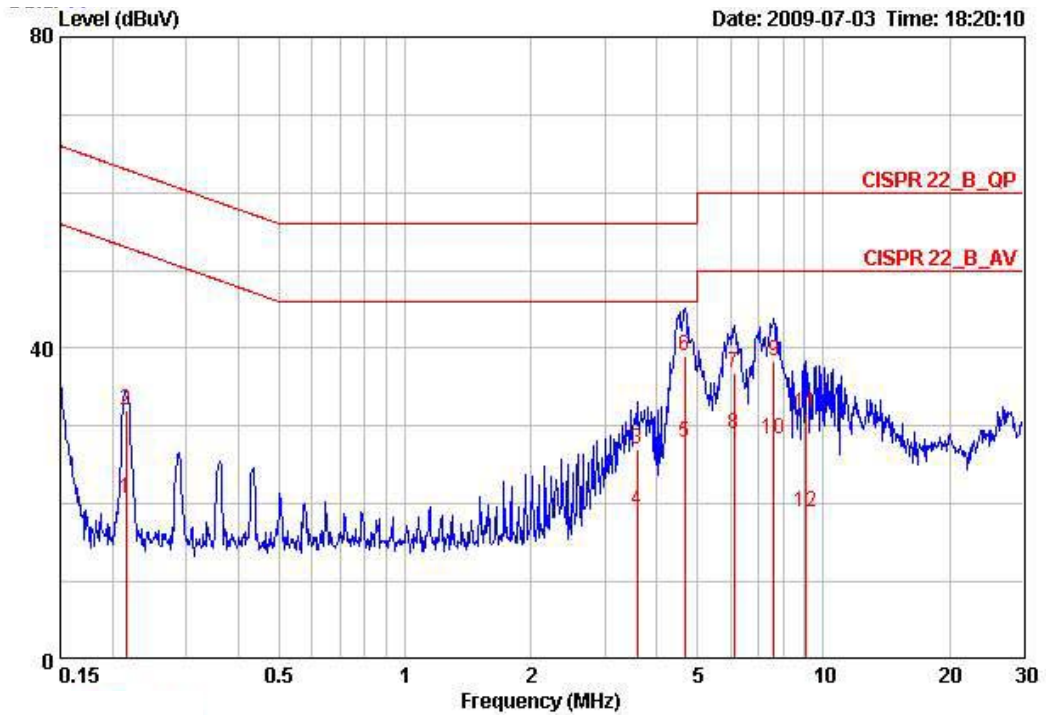

	Freq	Level	Over Limit	Limit Line	Read Level	LISN Factor	Cable Loss	Remark
	MHz	dBuV	dB	dBuV	dBuV	dB	dB	
1	0.21506	20.74	-32.27	53.01	20.49	0.05	0.20	AVERAGE
2	0.21506	32.06	-30.95	63.01	31.81	0.05	0.20	QP
3	3.584	26.92	-29.08	56.00	26.53	0.09	0.30	QP
4	3.584	19.11	-26.89	46.00	18.72	0.09	0.30	AVERAGE
5	4.672	27.82	-18.18	46.00	27.38	0.14	0.30	AVERAGE
6	4.672	39.12	-16.88	56.00	38.68	0.14	0.30	QP
7	6.121	36.79	-23.21	60.00	36.25	0.22	0.33	QP
8	6.121	29.00	-21.00	50.00	28.46	0.22	0.33	AVERAGE
9	7.606	38.31	-21.69	60.00	37.63	0.28	0.40	QP
10	7.606	28.31	-21.69	50.00	27.63	0.28	0.40	AVERAGE
11	9.059	31.59	-28.41	60.00	30.97	0.32	0.30	PEAK
12	9.059	18.87	-31.13	50.00	18.25	0.32	0.30	AVERAGE

Temperature	24.1°C	Humidity	53.4%
Test Engineer	Aric Li	Phase	Neutral
Configuration	Normal Link		

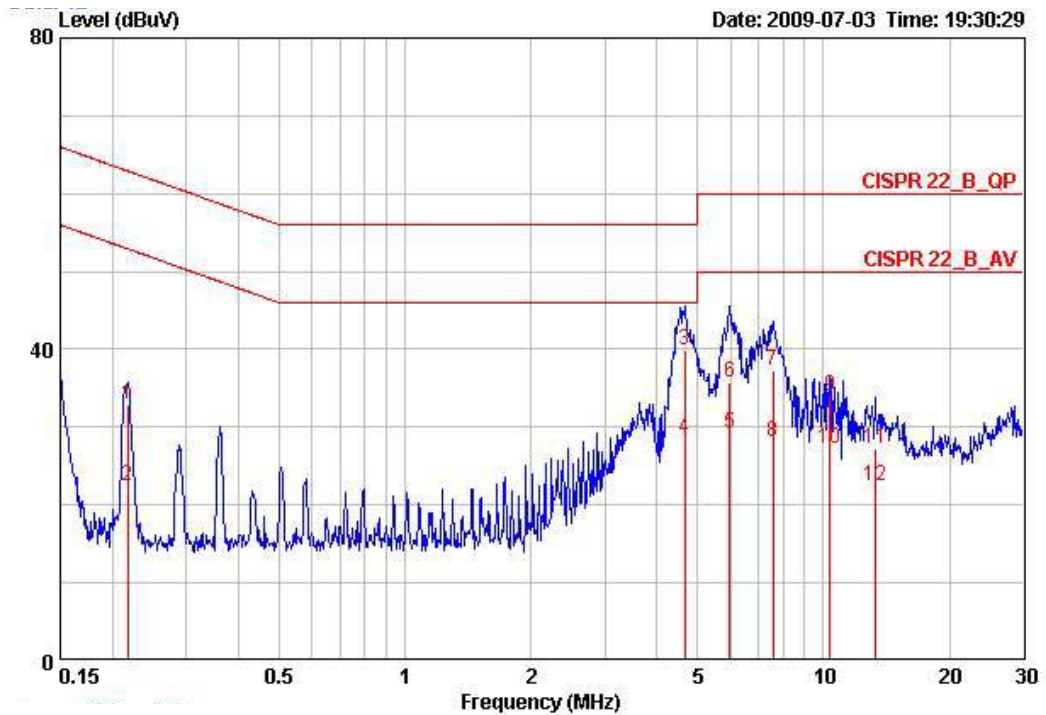

	Freq	Level	Over Limit	Limit Line	Read Level	LISN Factor	Cable Loss	Remark
	MHz	dBuV	dB	dBuV	dBuV	dB	dB	
1	0.21735	33.02	-29.90	62.92	32.74	0.08	0.20	QP
2	0.21735	22.51	-30.41	52.92	22.23	0.08	0.20	AVERAGE
3	4.672	39.92	-16.08	56.00	39.44	0.18	0.30	QP
4	4.672	28.61	-17.39	46.00	28.13	0.18	0.30	AVERAGE
5	5.961	29.21	-20.79	50.00	28.66	0.25	0.30	AVERAGE
6	5.961	35.69	-24.31	60.00	35.14	0.25	0.30	QP
7	7.566	37.34	-22.66	60.00	36.63	0.31	0.40	QP
8	7.566	28.17	-21.83	50.00	27.46	0.31	0.40	AVERAGE
9	10.379	34.03	-25.97	60.00	33.25	0.40	0.38	QP
10	10.379	27.33	-22.67	50.00	26.55	0.40	0.38	AVERAGE
11	13.267	27.20	-32.80	60.00	26.28	0.52	0.40	QP
12	13.267	22.56	-27.44	50.00	21.64	0.52	0.40	AVERAGE

Note:

$$\text{Level} = \text{Read Level} + \text{LISN Factor} + \text{Cable Loss}$$

4.2. 99% Occupied Bandwidth Measurement

4.2.1. Limit

No restriction limits. But resolution bandwidth within band edge measurement is 1% of the 99% occupied bandwidth.

4.2.2. Measuring Instruments and Setting

Please refer to section 5 of equipments list in this report. The following table is the setting of the spectrum analyzer.

Spectrum Parameters	Setting
Attenuation	Auto
Span Frequency	> 26dB Bandwidth
RB	300 kHz
VB	1000 kHz
Detector	Peak
Trace	Max Hold
Sweep Time	Auto

4.2.3. Test Procedures

1. The transmitter output (antenna port) was connected to the spectrum analyzer in peak hold mode.
2. The resolution bandwidth of 300 kHz and the video bandwidth of 1000 kHz were used.
3. Measured the spectrum width with power higher than 26dB below carrier.
4. Measuring multiple antennas, the connector is required to link with spectrum analyzer through a combiner.

4.2.4. Test Setup Layout

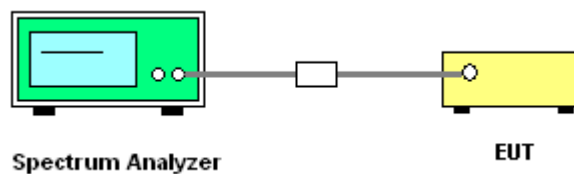

4.2.5. Test Deviation

There is no deviation with the original standard.

4.2.6. EUT Operation during Test

The EUT was programmed to be in continuously transmitting mode.

4.2.7. Test Result of 99% Occupied Bandwidth

<For Antenna 1>:

Temperature	21°C	Humidity	56%
Test Engineer	Sam Chen	Configurations	Draft n / Antenna 1

Configuration Draft n MCS0 20MHz Ant. 1-1 + Ant. 1-2 + Ant. 1-3

Channel	Frequency	26dB Bandwidth (MHz)	99% Occupied Bandwidth (MHz)
52	5260 MHz	26.88	18.08
60	5300 MHz	31.36	17.92
64	5320 MHz	22.88	17.92
100	5500 MHz	21.92	16.80
116	5580 MHz	35.20	17.44
140	5700 MHz	21.92	17.12

Configuration Draft n MCS0 40MHz Ant. 1-1 + Ant. 1-2 + Ant. 1-3

Channel	Frequency	26dB Bandwidth (MHz)	99% Occupied Bandwidth (MHz)
54	5270 MHz	44.64	36.48
62	5310 MHz	42.56	36.32
102	5510MHz	42.72	36.32
110	5550 MHz	47.04	36.64
134	5670 MHz	47.68	36.48

Temperature	21°C	Humidity	56%
Test Engineer	Sam Chen	Configurations	802.11a / Antenna 1

Configuration IEEE 802.11a Ant. 1-1 + Ant. 1-2 + Ant. 1-3

Channel	Frequency	26dB Bandwidth (MHz)	99% Occupied Bandwidth (MHz)
52	5260 MHz	25.28	17.12
60	5300 MHz	30.72	17.44
64	5320 MHz	21.44	16.96
100	5500 MHz	21.44	16.80
116	5580 MHz	28.48	17.44
140	5700 MHz	23.20	17.12

<For Antenna 2>:

Temperature	21°C	Humidity	56%
Test Engineer	Sam Chen	Configurations	Draft n / Antenna 2

Configuration Draft n MCS0 20MHz Ant. 2-1 + Ant. 2-2 + Ant. 2-3

Channel	Frequency	26dB Bandwidth (MHz)	99% Occupied Bandwidth (MHz)
52	5260 MHz	22.72	17.76
60	5300 MHz	22.88	17.92
64	5320 MHz	22.72	17.76
100	5500 MHz	23.04	17.92
116	5580 MHz	22.72	17.76
140	5700 MHz	21.92	17.76

Configuration Draft n MCS0 40MHz Ant. 2-1 + Ant. 2-2 + Ant. 2-3

Channel	Frequency	26dB Bandwidth (MHz)	99% Occupied Bandwidth (MHz)
54	5270 MHz	42.88	36.32
62	5310 MHz	42.72	36.32
102	5510MHz	43.20	36.32
110	5550 MHz	43.04	36.32
134	5670 MHz	43.04	36.32

Temperature	21°C	Humidity	56%
Test Engineer	Sam Chen	Configurations	802.11a / Antenna 2

Configuration IEEE 802.11a Ant. 2-1 + Ant. 2-2 + Ant. 2-3

Channel	Frequency	26dB Bandwidth (MHz)	99% Occupied Bandwidth (MHz)
52	5260 MHz	21.76	16.96
60	5300 MHz	21.60	16.80
64	5320 MHz	21.76	16.96
100	5500 MHz	21.44	16.96
116	5580 MHz	21.12	16.80
140	5700 MHz	21.92	16.96

<For Antenna 3>:

Temperature	21°C	Humidity	56%
Test Engineer	Sam Chen	Configurations	Draft n / Antenna 3

Configuration Draft n MCS0 20MHz Ant. 3-1 + Ant. 3-2 + Ant. 3-3

Channel	Frequency	26dB Bandwidth (MHz)	99% Occupied Bandwidth (MHz)
52	5260 MHz	22.88	17.92
60	5300 MHz	23.04	17.92
64	5320 MHz	22.72	17.76
100	5500 MHz	23.04	17.92
116	5580 MHz	22.72	17.76
140	5700 MHz	22.24	17.76

Configuration Draft n MCS0 40MHz Ant. 3-1 + Ant. 3-2 + Ant. 3-3

Channel	Frequency	26dB Bandwidth (MHz)	99% Occupied Bandwidth (MHz)
54	5270 MHz	43.04	36.48
62	5310 MHz	42.72	36.32
102	5510MHz	42.88	36.48
110	5550 MHz	43.52	36.48
134	5670 MHz	42.88	36.32

Temperature	21°C	Humidity	56%
Test Engineer	Sam Chen	Configurations	802.11a / Antenna 3

Configuration IEEE 802.11a Ant. 3-1 + Ant. 3-2 + Ant. 3-3

Channel	Frequency	26dB Bandwidth (MHz)	99% Occupied Bandwidth (MHz)
52	5260 MHz	21.76	16.80
60	5300 MHz	21.92	17.12
64	5320 MHz	21.92	17.12
100	5500 MHz	22.08	16.96
116	5580 MHz	21.28	16.96
140	5700 MHz	21.76	16.96

<For Antenna 4>:

Temperature	21°C	Humidity	56%
Test Engineer	Sam Chen	Configurations	Draft n / Antenna 4

Configuration Draft n MCS0 20MHz Ant. 4-1 + Ant. 4-3

Channel	Frequency	26dB Bandwidth (MHz)	99% Occupied Bandwidth (MHz)
52	5260 MHz	22.72	17.92
60	5300 MHz	22.72	17.92
64	5320 MHz	22.56	17.76
100	5500 MHz	23.20	17.92
116	5580 MHz	23.04	17.76
140	5700 MHz	22.72	17.76

Configuration Draft n MCS0 40MHz Ant. 4-1 + Ant. 4-3

Channel	Frequency	26dB Bandwidth (MHz)	99% Occupied Bandwidth (MHz)
54	5270 MHz	42.72	36.64
62	5310 MHz	42.72	36.32
102	5510MHz	43.36	36.32
110	5550 MHz	42.72	36.32
134	5670 MHz	43.03	36.32

Temperature	21°C	Humidity	56%
Test Engineer	Sam Chen	Configurations	802.11a / Antenna 4

Configuration IEEE 802.11a Ant. 4-1 + Ant. 4-3

Channel	Frequency	26dB Bandwidth (MHz)	99% Occupied Bandwidth (MHz)
52	5260 MHz	22.40	17.92
60	5300 MHz	21.92	16.80
64	5320 MHz	20.80	16.80
100	5500 MHz	21.76	16.80
116	5580 MHz	20.80	17.12
140	5700 MHz	21.92	16.96

<For Antenna 1>:

26 dB Bandwidth Plot on Configuration Drafft n MCS0 20MHz Ant. 1-1 + Ant. 1-2 + Ant. 1-3 / 5260 MHz

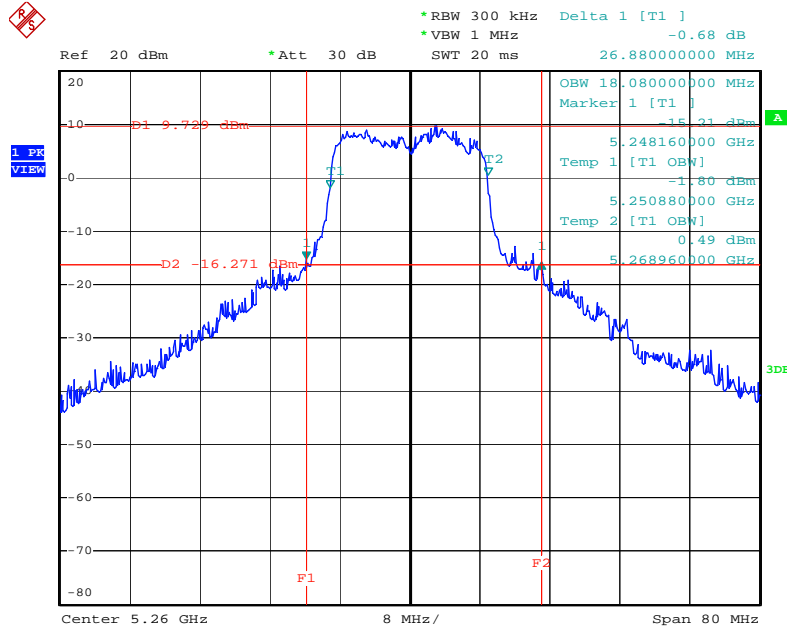

Date: 4.JUL.2009 11:34:35

26 dB Bandwidth Plot on Configuration Drafft n MCS0 20MHz Ant. 1-1 + Ant. 1-2 + Ant. 1-3 / 5300 MHz

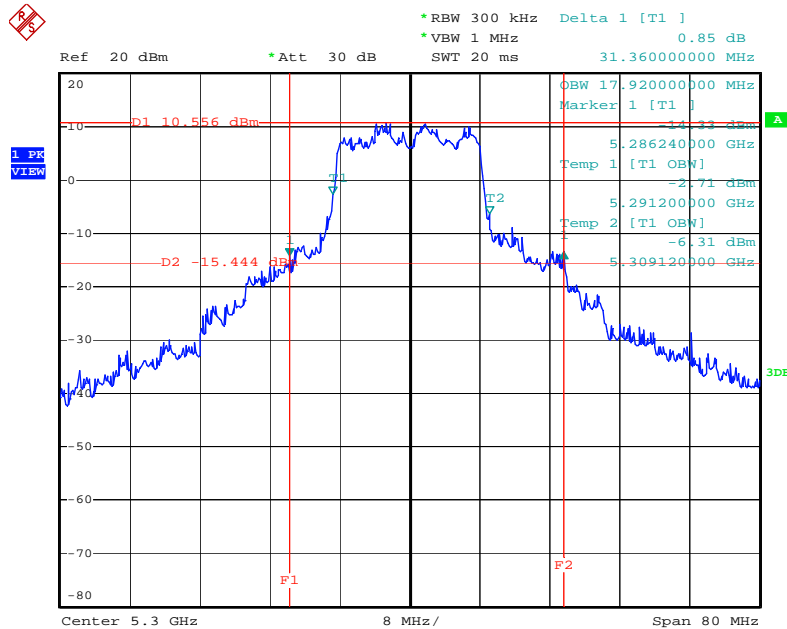

Date: 4.JUL.2009 14:59:19

26 dB Bandwidth Plot on Configuration Drafft n MCS0 20MHz Ant. 1-1 + Ant. 1-2 + Ant. 1-3 / 5320 MHz

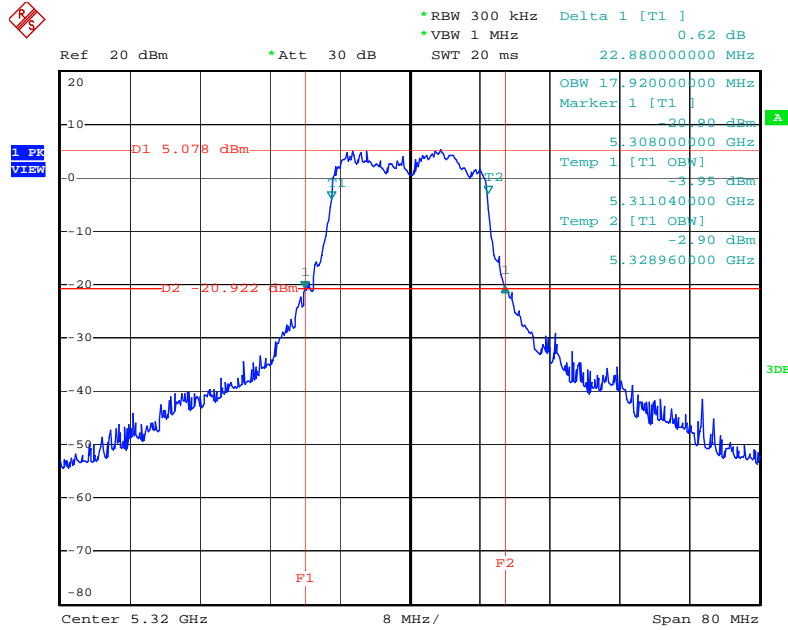

Date: 4.JUL.2009 11:36:18

26 dB Bandwidth Plot on Configuration Drafft n MCS0 20MHz Ant. 1-1 + Ant. 1-2 + Ant. 1-3 / 5500 MHz

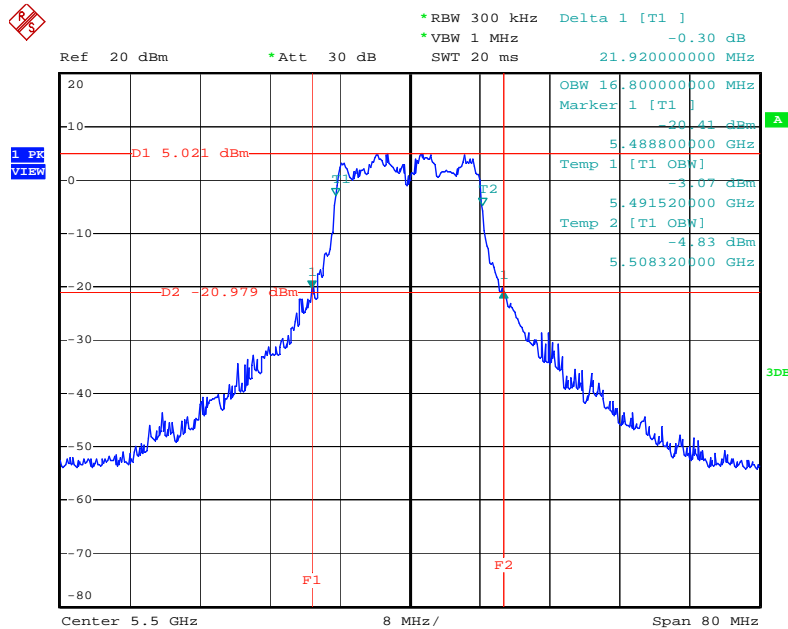

Date: 4.JUL.2009 11:37:51

26 dB Bandwidth Plot on Configuration Drafft n MCS0 20MHz Ant. 1-1 + Ant. 1-2 + Ant. 1-3 / 5580 MHz

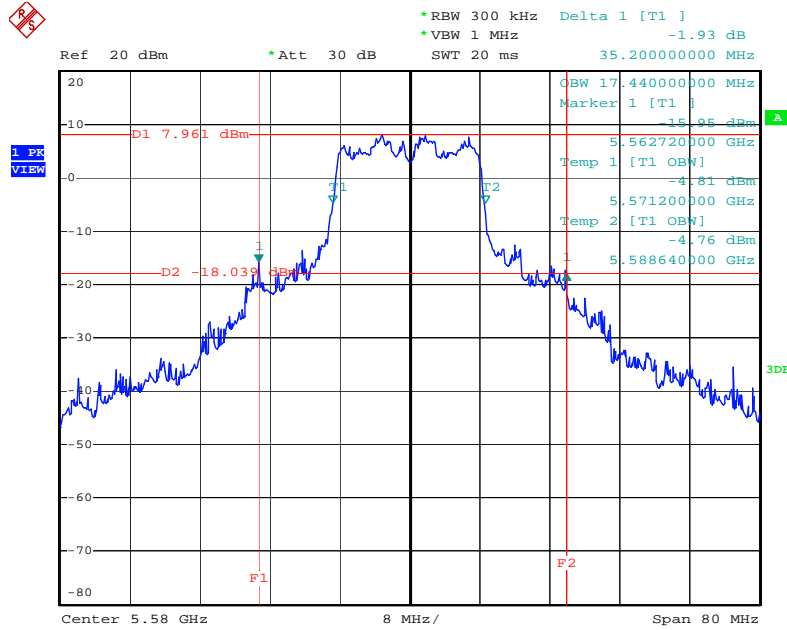

Date: 4.JUL.2009 11:39:44

26 dB Bandwidth Plot on Configuration Drafft n MCS0 20MHz Ant. 1-1 + Ant. 1-2 + Ant. 1-3 / 5700 MHz

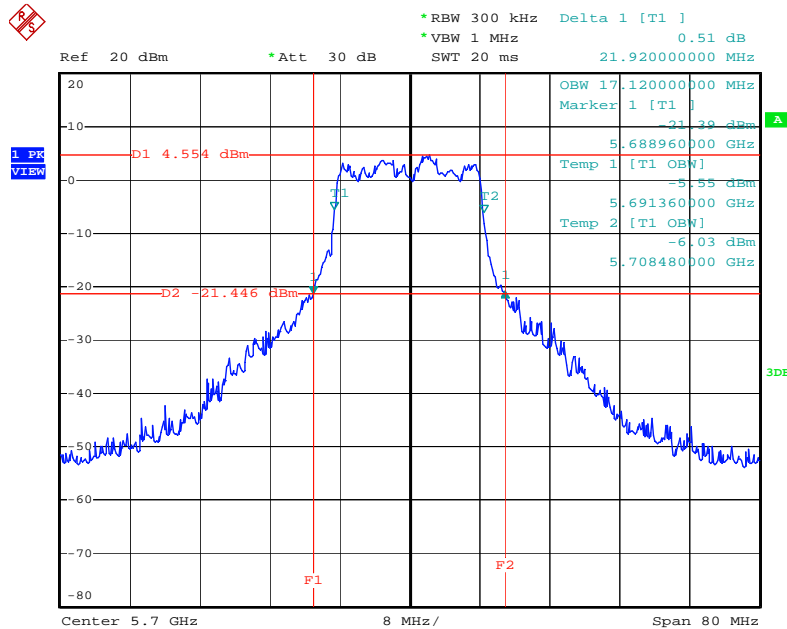

Date: 4.JUL.2009 11:41:18

26 dB Bandwidth Plot on Configuration Drafft n MCS0 40MHz Ant. 1-1 + Ant. 1-2 + Ant. 1-3 / 5270 MHz

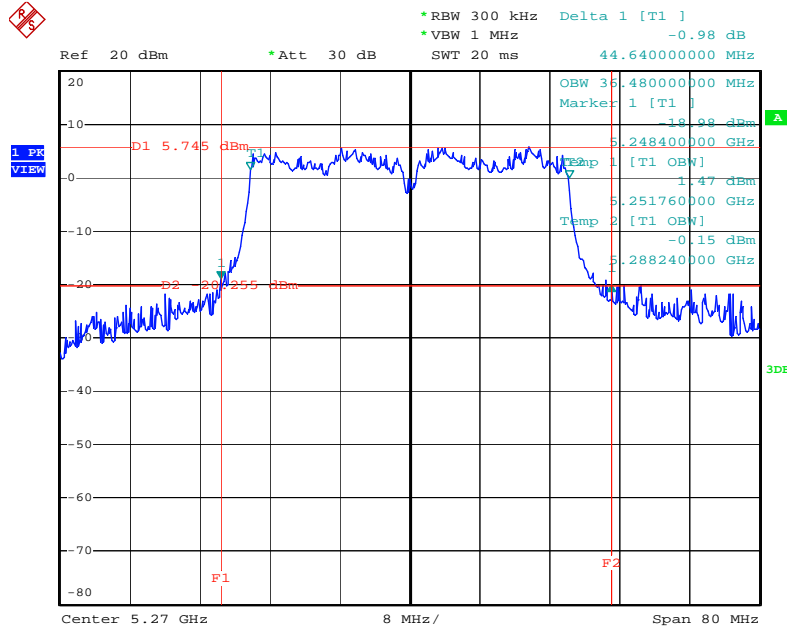

Date: 4.JUL.2009 12:01:00

26 dB Bandwidth Plot on Configuration Drafft n MCS0 40MHz Ant. 1-1 + Ant. 1-2 + Ant. 1-3 / 5310 MHz

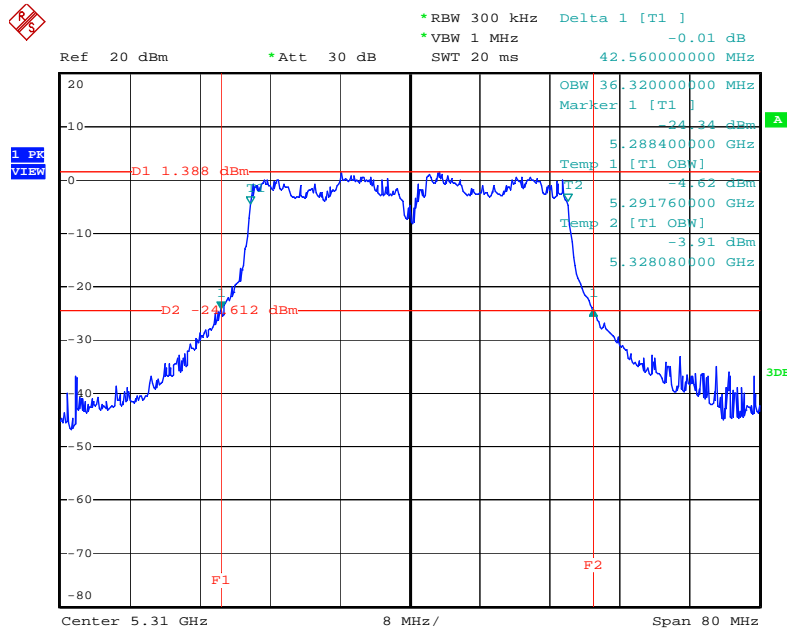

Date: 4.JUL.2009 12:02:13

26 dB Bandwidth Plot on Configuration Drafft n MCS0 40MHz Ant. 1-1 + Ant. 1-2 + Ant. 1-3 / 5510MHz

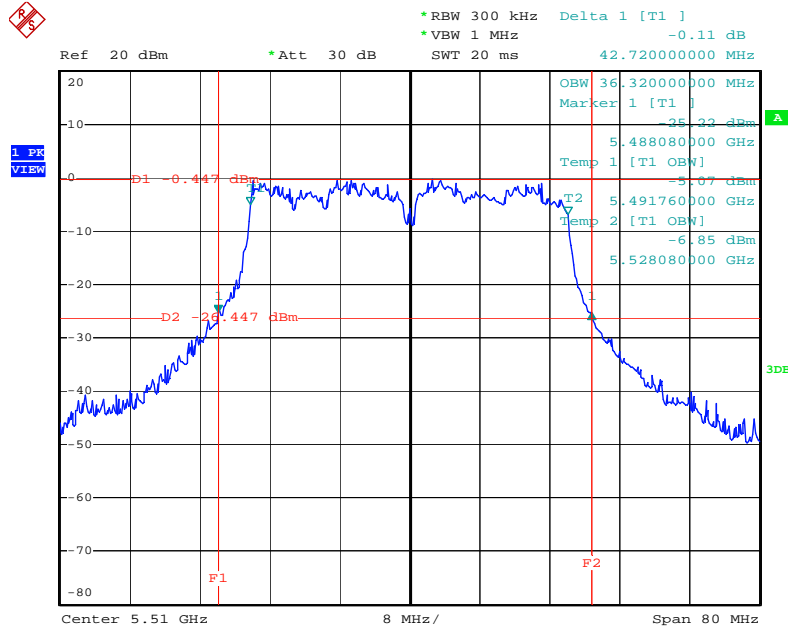

Date: 4.JUL.2009 12:03:42

26 dB Bandwidth Plot on Configuration Drafft n MCS0 40MHz Ant. 1-1 + Ant. 1-2 + Ant. 1-3 / 5550 MHz

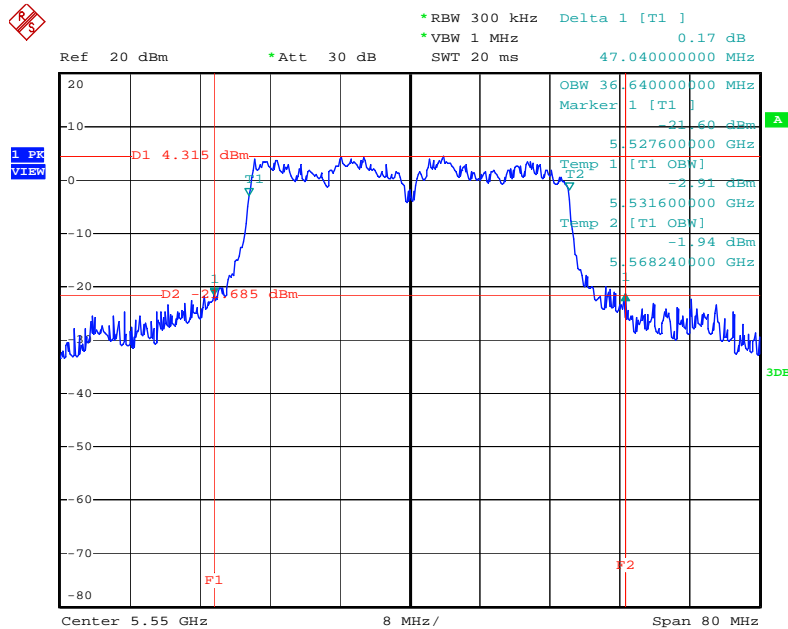

Date: 4.JUL.2009 12:07:51

26 dB Bandwidth Plot on Configuration Drafft n MCS0 40MHz Ant. 1-1 + Ant. 1-2 + Ant. 1-3 / 5670 MHz

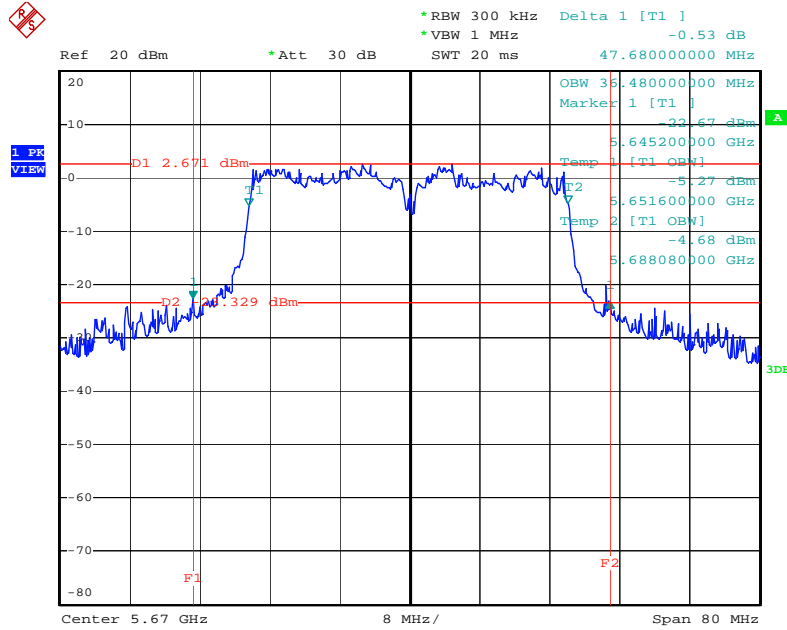

Date: 4.JUL.2009 12:09:51

26 dB Bandwidth Plot on Configuration IEEE 802.11a Ant. 1-1 + Ant. 1-2 + Ant. 1-3 / 5260 MHz

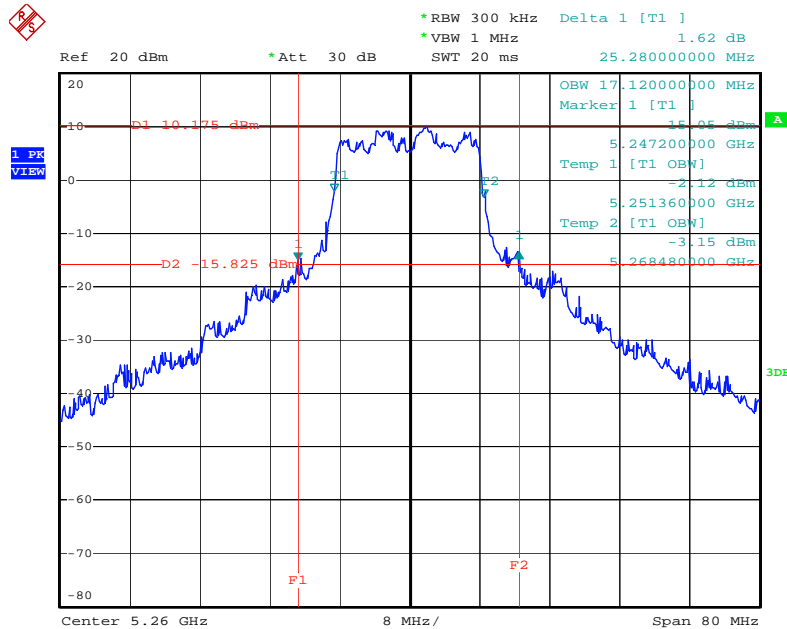

Date: 4.JUL.2009 11:16:24

26 dB Bandwidth Plot on Configuration IEEE 802.11a Ant. 1-1 + Ant. 1-2 + Ant. 1-3 / 5300 MHz

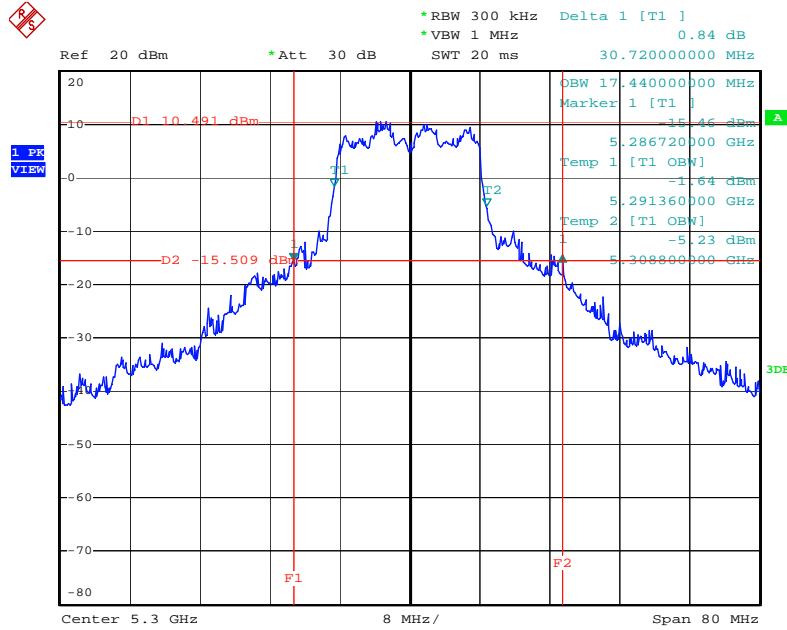

Date: 4.JUL.2009 11:19:57

26 dB Bandwidth Plot on Configuration IEEE 802.11a Ant. 1-1 + Ant. 1-2 + Ant. 1-3 / 5320 MHz

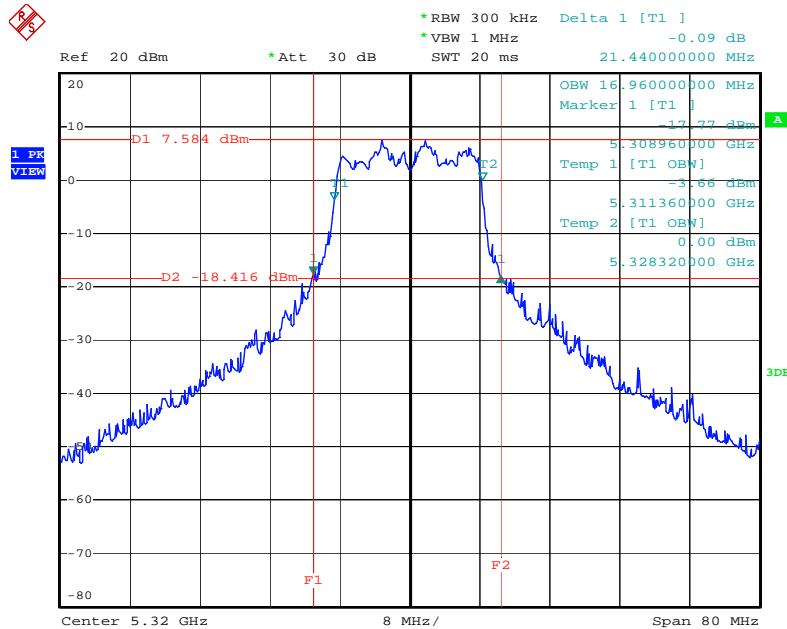

Date: 4.JUL.2009 11:21:12

26 dB Bandwidth Plot on Configuration IEEE 802.11a Ant. 1-1 + Ant. 1-2 + Ant. 1-3 / 5500 MHz

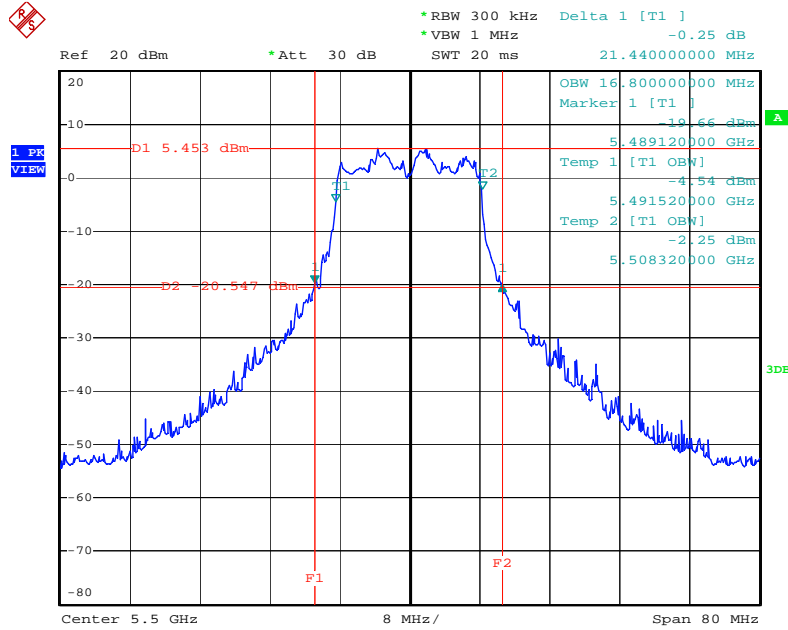

Date: 4.JUL.2009 11:22:42

26 dB Bandwidth Plot on Configuration IEEE 802.11a Ant. 1-1 + Ant. 1-2 + Ant. 1-3 / 5580 MHz

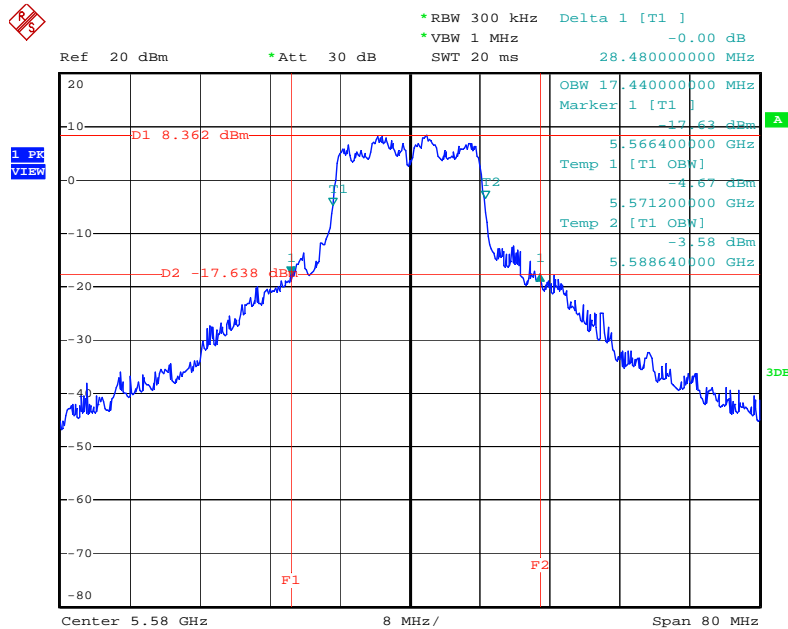

Date: 4.JUL.2009 11:24:32

26 dB Bandwidth Plot on Configuration IEEE 802.11a Ant. 1-1 + Ant. 1-2 + Ant. 1-3 / 5700 MHz

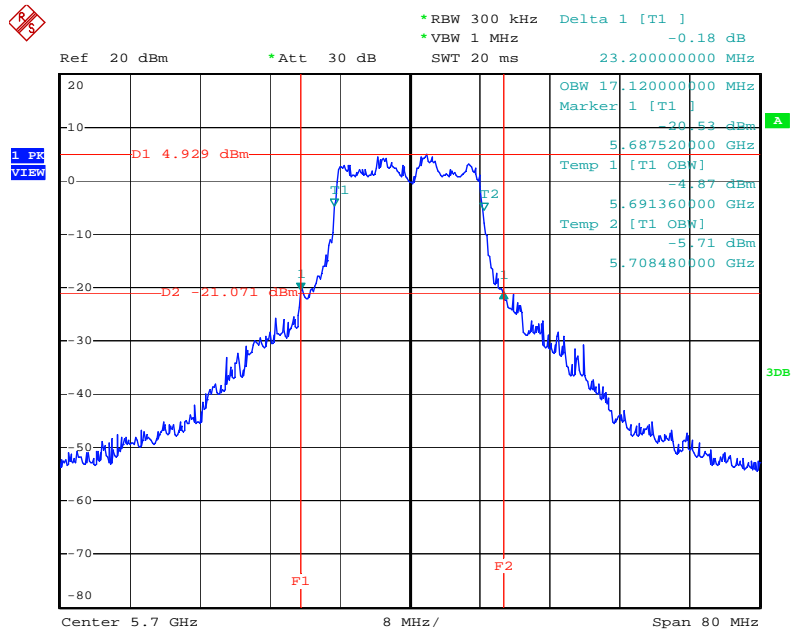

Date: 4.JUL.2009 11:25:51

<For Antenna 2>:

26 dB Bandwidth Plot on Configuration Drafft n MCS0 20MHz Ant. 2-1 + Ant. 2-2 + Ant. 2-3 / 5260 MHz

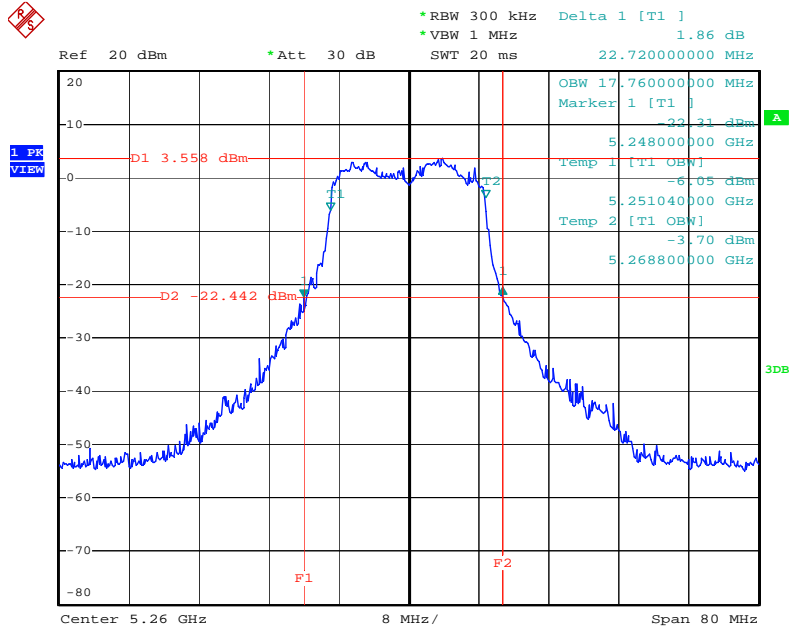

Date: 4.JUL.2009 12:55:34

26 dB Bandwidth Plot on Configuration Drafft n MCS0 20MHz Ant. 2-1 + Ant. 2-2 + Ant. 2-3 / 5300 MHz

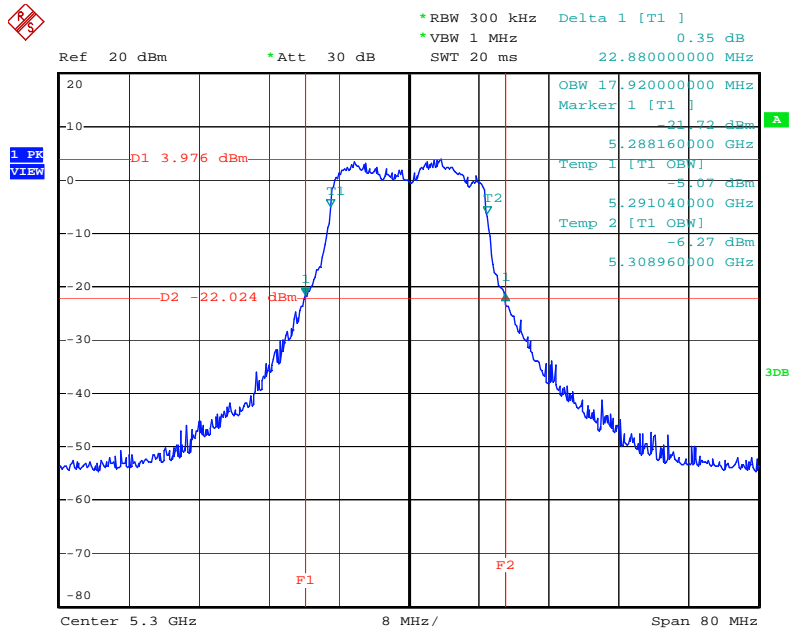

Date: 4.JUL.2009 12:57:00

26 dB Bandwidth Plot on Configuration Drafft n MCS0 20MHz Ant. 2-1 + Ant. 2-2 + Ant. 2-3 / 5320 MHz

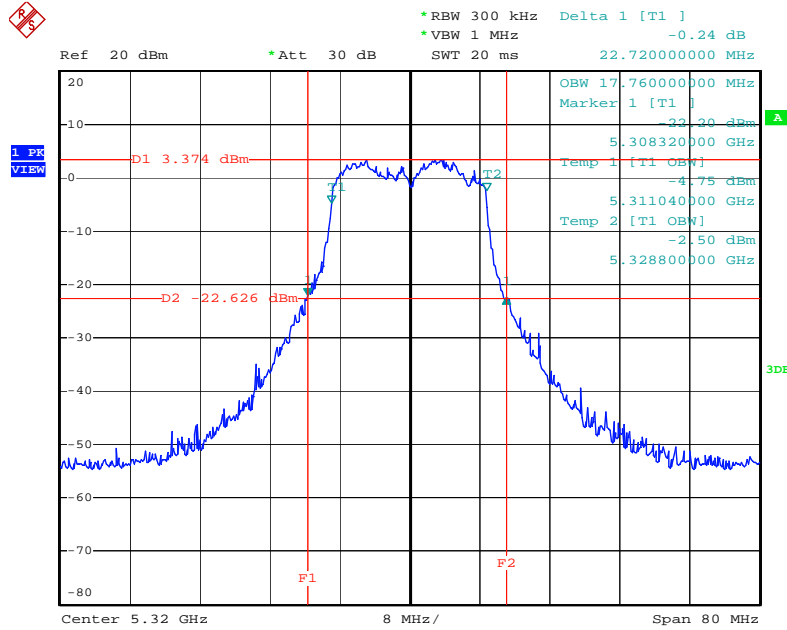

Date: 4.JUL.2009 12:58:52

26 dB Bandwidth Plot on Configuration Drafft n MCS0 20MHz Ant. 2-1 + Ant. 2-2 + Ant. 2-3 / 5500 MHz

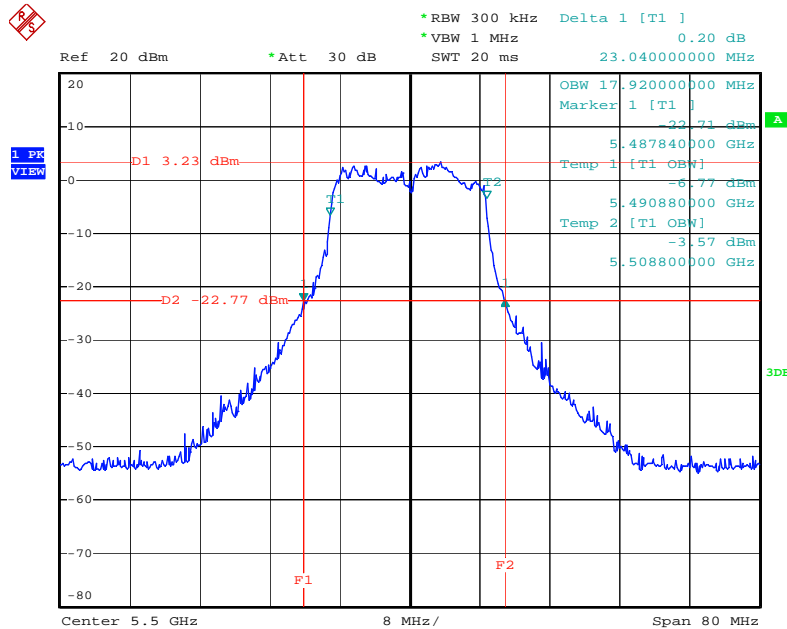

Date: 4.JUL.2009 13:00:27

26 dB Bandwidth Plot on Configuration Drafft n MCS0 20MHz Ant. 2-1 + Ant. 2-2 + Ant. 2-3 / 5580 MHz

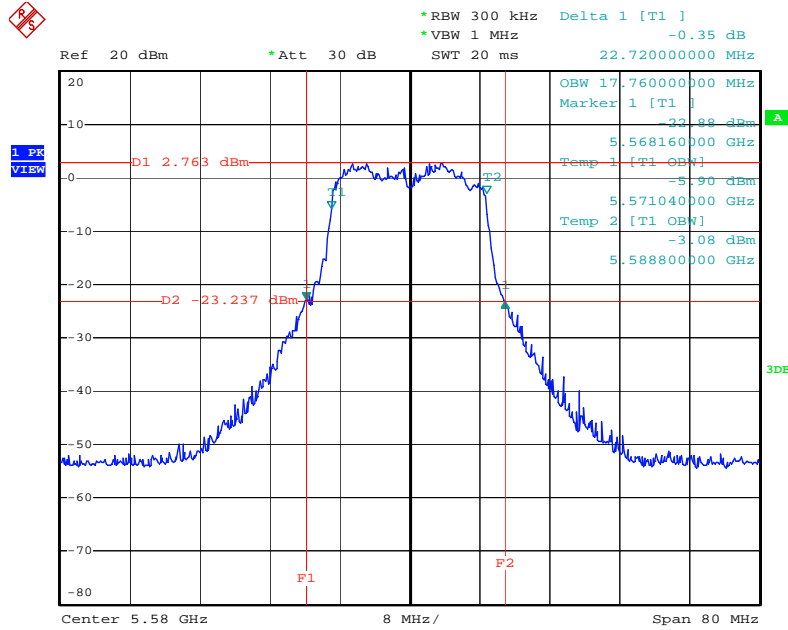

Date: 4.JUL.2009 13:02:44

26 dB Bandwidth Plot on Configuration Drafft n MCS0 20MHz Ant. 2-1 + Ant. 2-2 + Ant. 2-3 / 5700 MHz

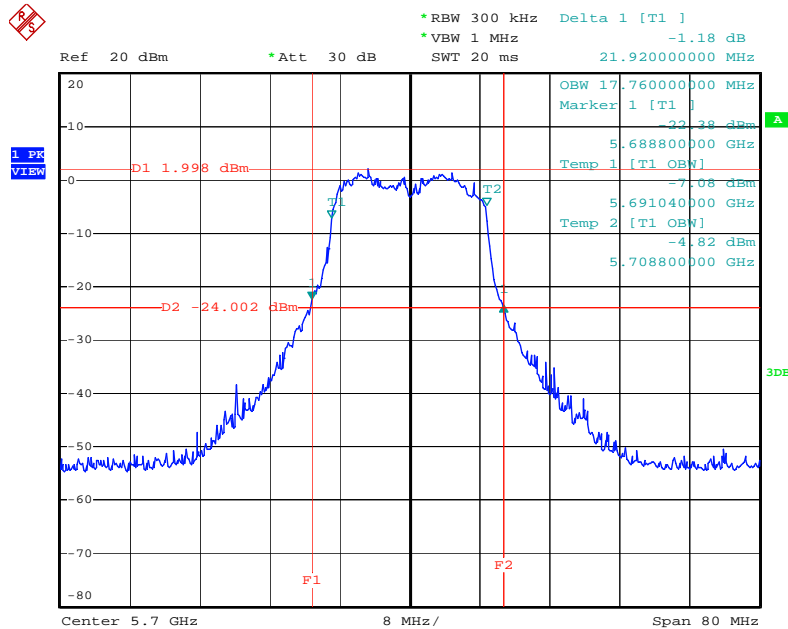

Date: 4.JUL.2009 13:04:40

26 dB Bandwidth Plot on Configuration Drafft n MCS0 40MHz Ant. 2-1 + Ant. 2-2 + Ant. 2-3 / 5270 MHz

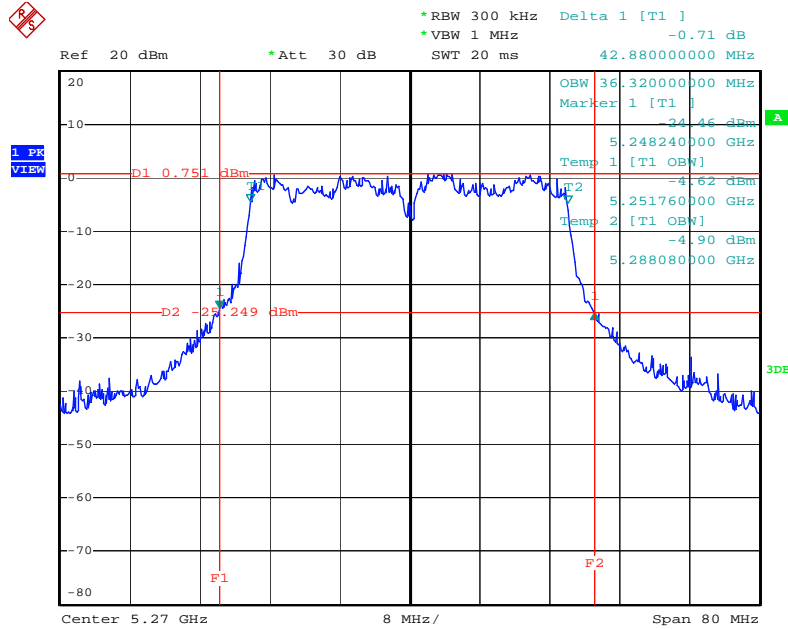

Date: 4.JUL.2009 13:12:58

26 dB Bandwidth Plot on Configuration Drafft n MCS0 40MHz Ant. 2-1 + Ant. 2-2 + Ant. 2-3 / 5310 MHz

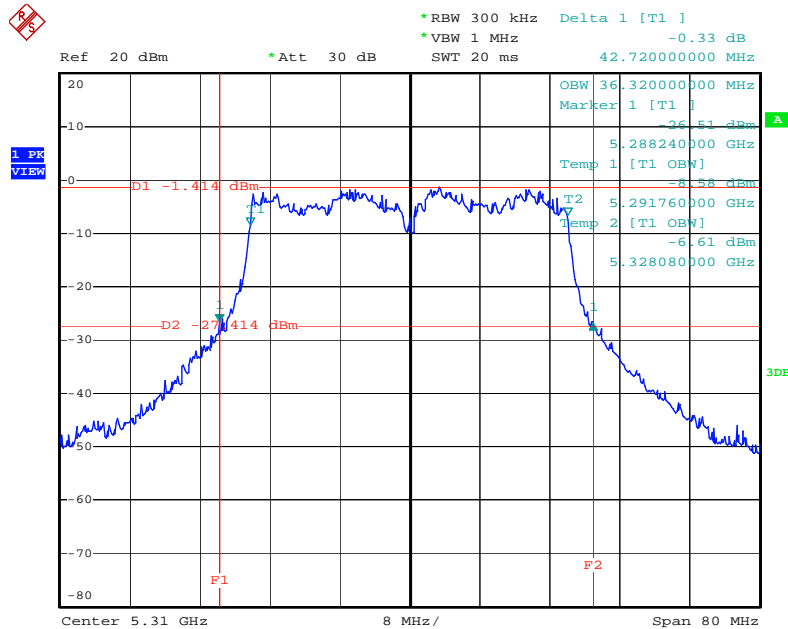

Date: 4.JUL.2009 13:15:02

26 dB Bandwidth Plot on Configuration Drafft n MCS0 40MHz Ant. 2-1 + Ant. 2-2 + Ant. 2-3 / 5510MHz

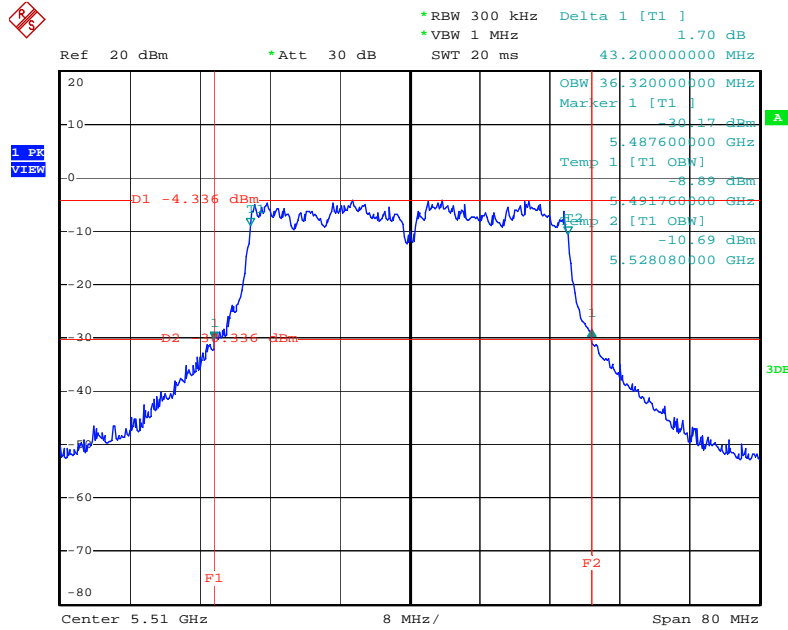

Date: 4.JUL.2009 13:16:33

26 dB Bandwidth Plot on Configuration Drafft n MCS0 40MHz Ant. 2-1 + Ant. 2-2 + Ant. 2-3 / 5550 MHz

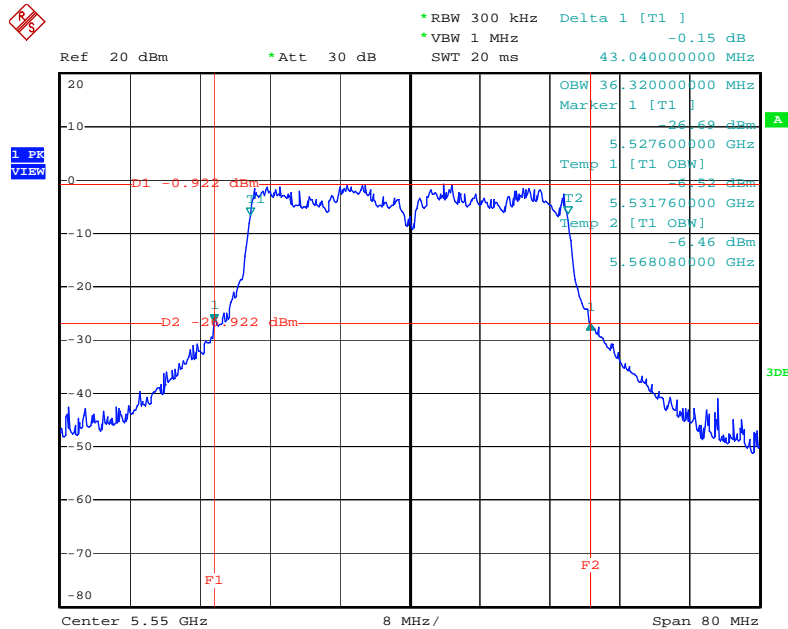

Date: 4.JUL.2009 13:17:53

26 dB Bandwidth Plot on Configuration Drafft n MCS0 40MHz Ant. 2-1 + Ant. 2-2 + Ant. 2-3 / 5670 MHz

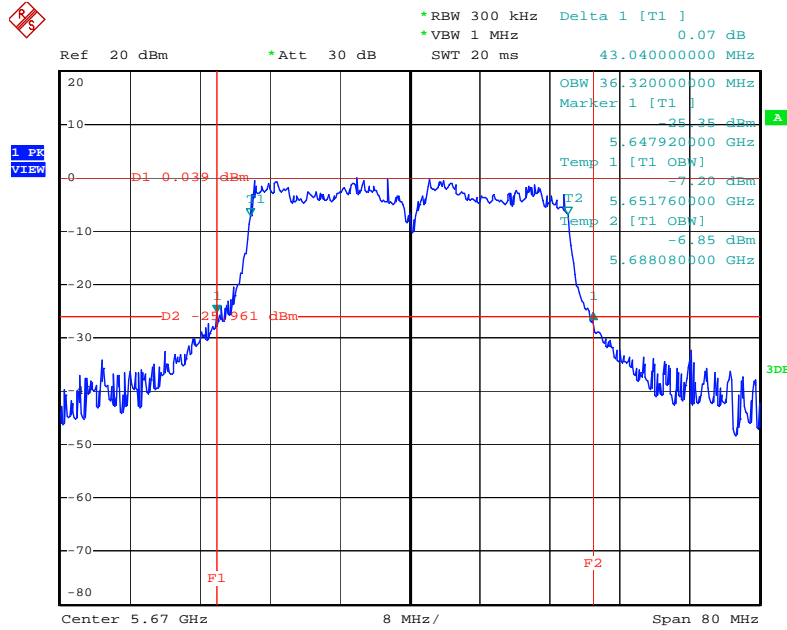

Date: 4.JUL.2009 13:19:28

26 dB Bandwidth Plot on Configuration IEEE 802.11a Ant. 2-1 + Ant. 2-2 + Ant. 2-3 / 5260 MHz

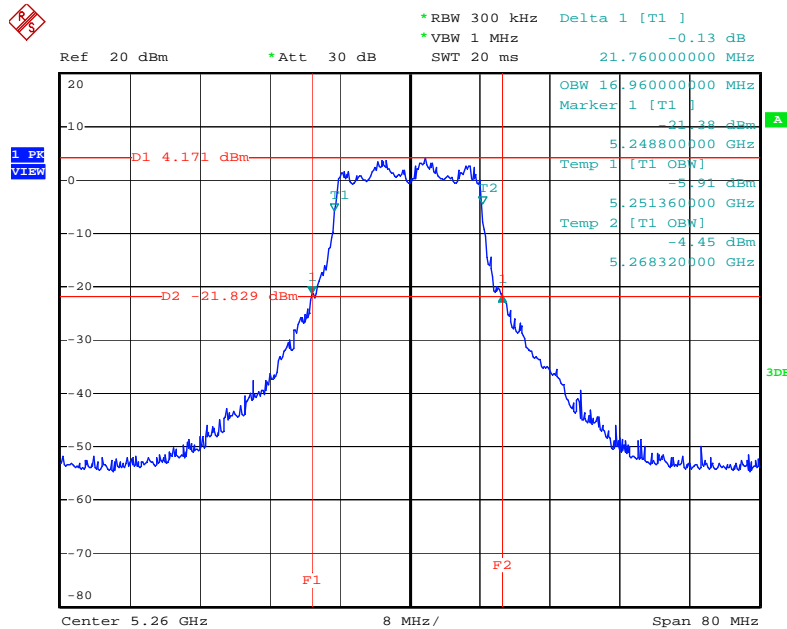

Date: 4.JUL.2009 12:26:19

26 dB Bandwidth Plot on Configuration IEEE 802.11a Ant. 2-1 + Ant. 2-2 + Ant. 2-3 / 5300 MHz

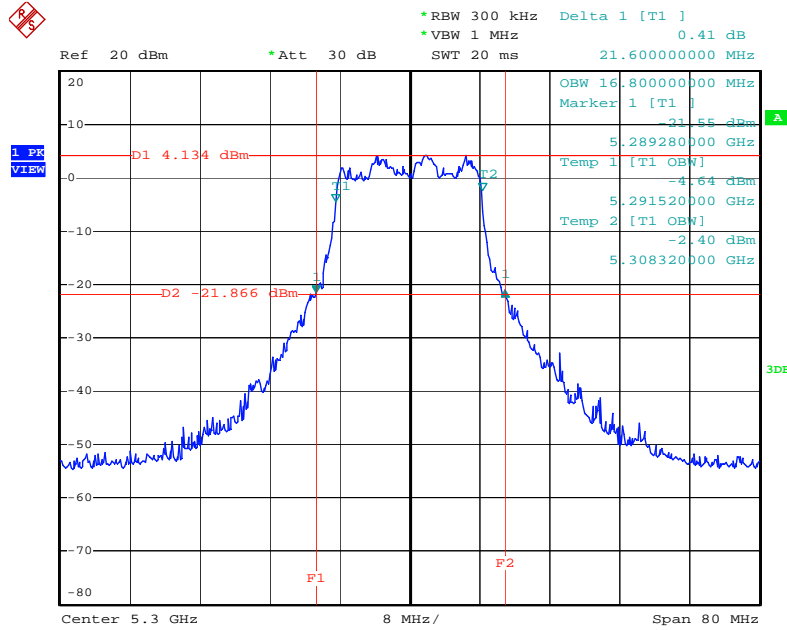

Date: 4.JUL.2009 12:36:51

26 dB Bandwidth Plot on Configuration IEEE 802.11a Ant. 2-1 + Ant. 2-2 + Ant. 2-3 / 5320 MHz

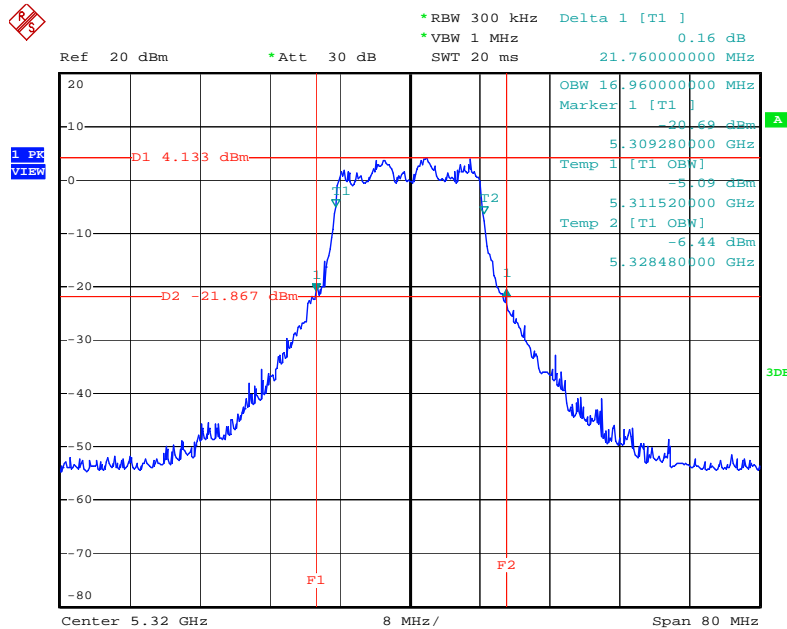

Date: 4.JUL.2009 12:38:27

26 dB Bandwidth Plot on Configuration IEEE 802.11a Ant. 2-1 + Ant. 2-2 + Ant. 2-3 / 5500 MHz

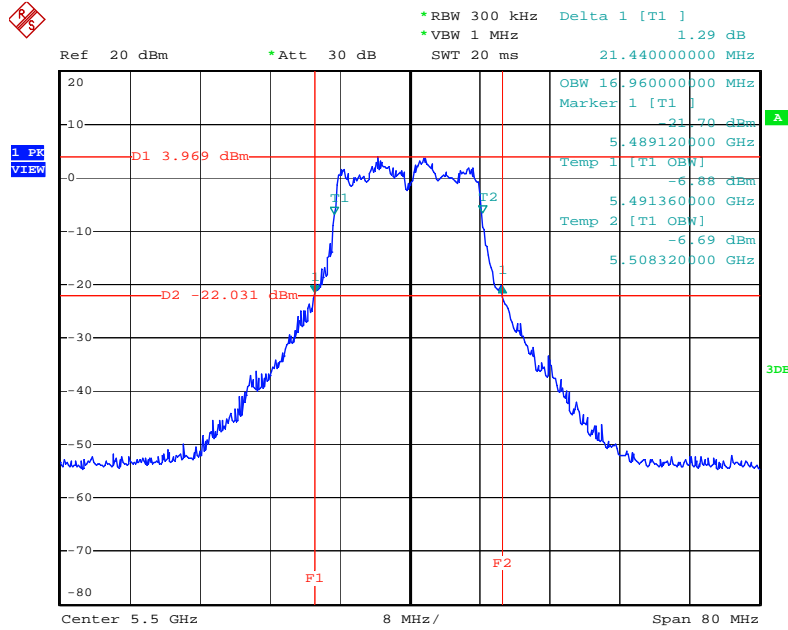

Date: 4.JUL.2009 12:46:35

26 dB Bandwidth Plot on Configuration IEEE 802.11a Ant. 2-1 + Ant. 2-2 + Ant. 2-3 / 5580 MHz

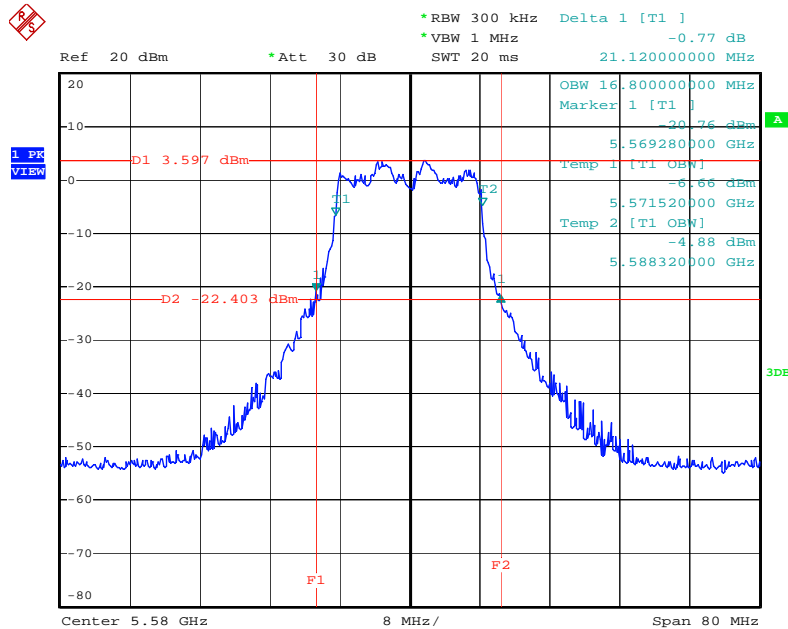

Date: 4.JUL.2009 12:47:53

26 dB Bandwidth Plot on Configuration IEEE 802.11a Ant. 2-1 + Ant. 2-2 + Ant. 2-3 / 5700 MHz

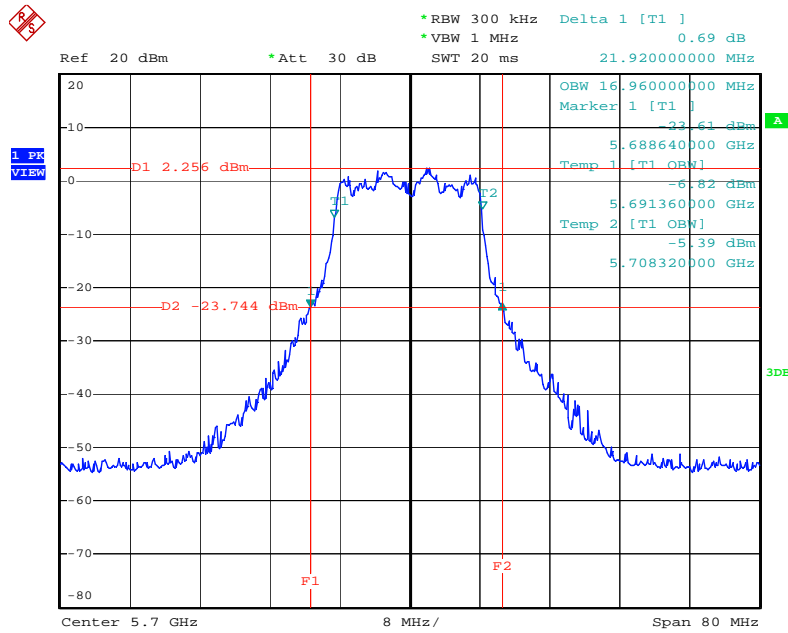

Date: 4.JUL.2009 12:49:10

<For Antenna 3>:

26 dB Bandwidth Plot on Configuration Drafft n MCS0 20MHz Ant. 3-1 + Ant. 3-2 + Ant. 3-3 / 5260 MHz

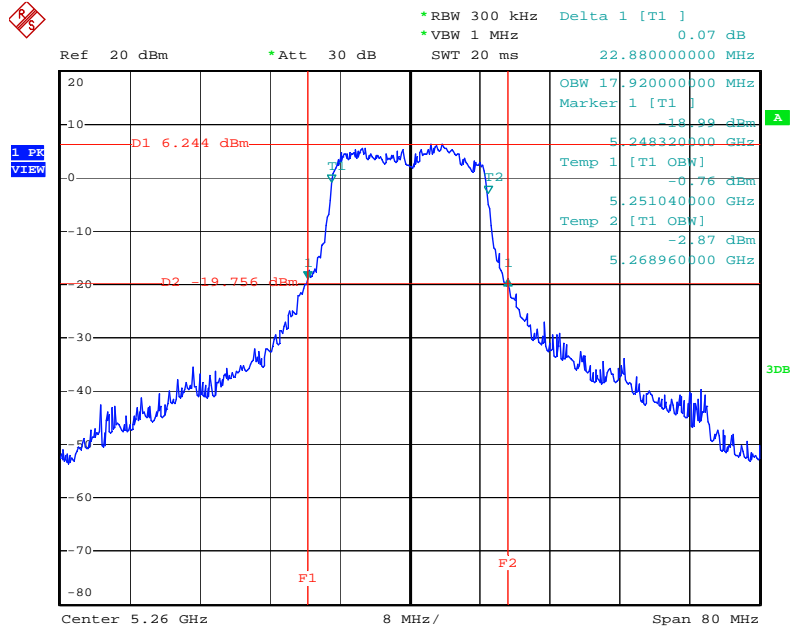

Date: 4.JUL.2009 13:37:46

26 dB Bandwidth Plot on Configuration Drafft n MCS0 20MHz Ant. 3-1 + Ant. 3-2 + Ant. 3-3 / 5300 MHz

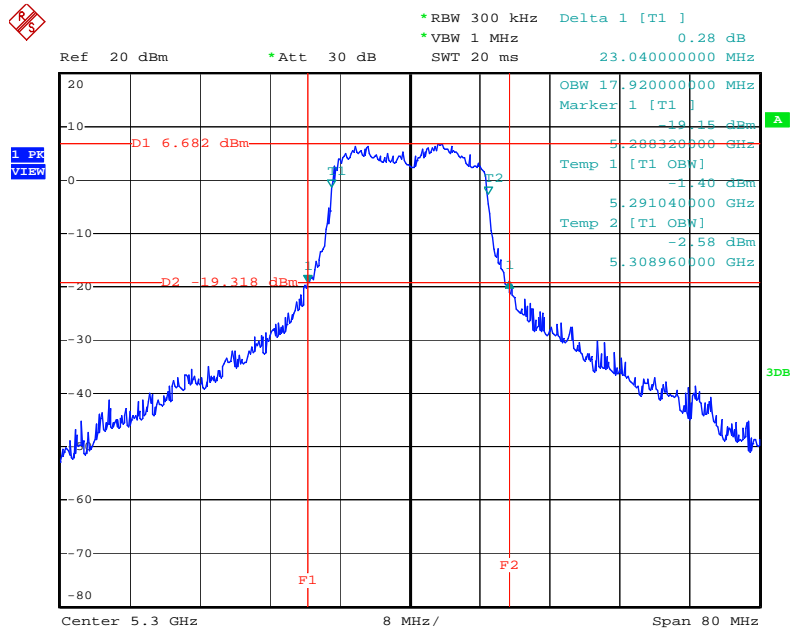

Date: 4.JUL.2009 13:39:14

26 dB Bandwidth Plot on Configuration Drafft n MCS0 20MHz Ant. 3-1 + Ant. 3-2 + Ant. 3-3 / 5320 MHz

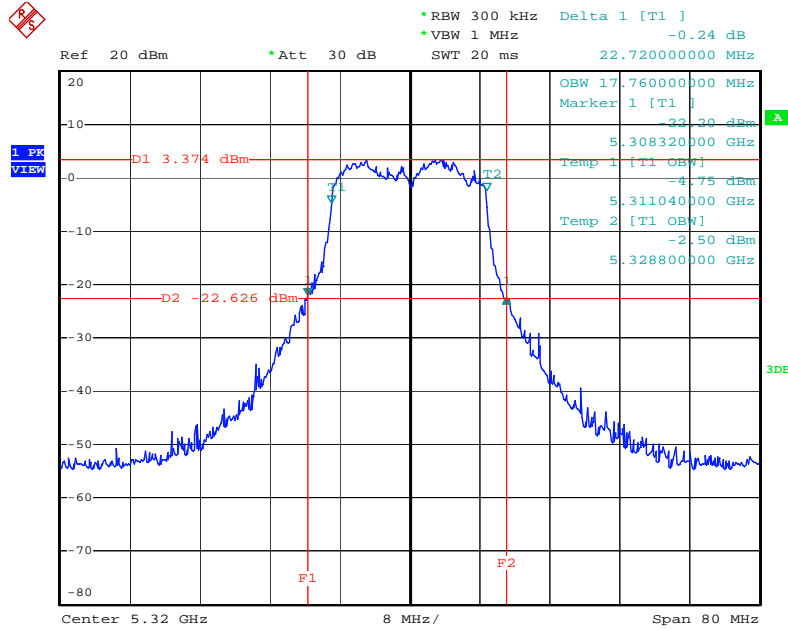

Date: 4.JUL.2009 12:58:52

26 dB Bandwidth Plot on Configuration Drafft n MCS0 20MHz Ant. 3-1 + Ant. 3-2 + Ant. 3-3 / 5500 MHz

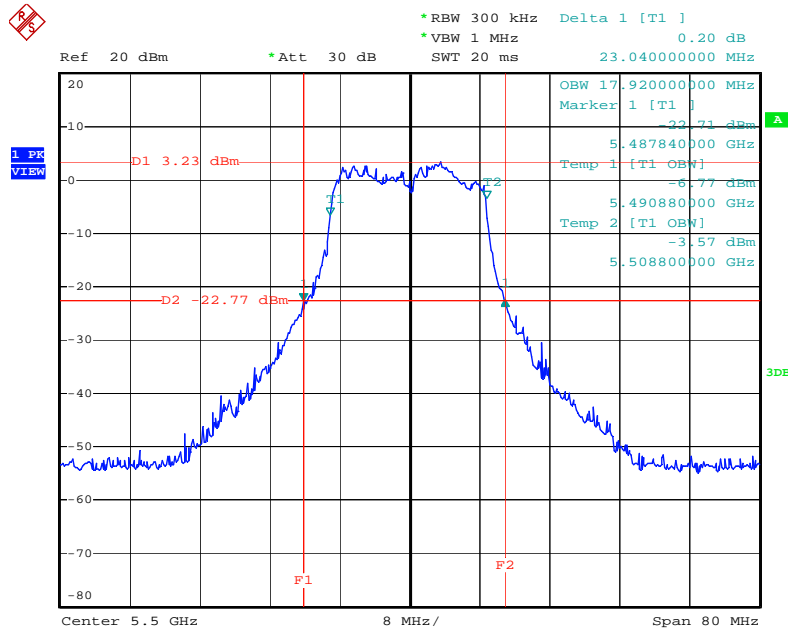

Date: 4.JUL.2009 13:00:27

26 dB Bandwidth Plot on Configuration Drafft n MCS0 20MHz Ant. 3-1 + Ant. 3-2 + Ant. 3-3 / 5580 MHz

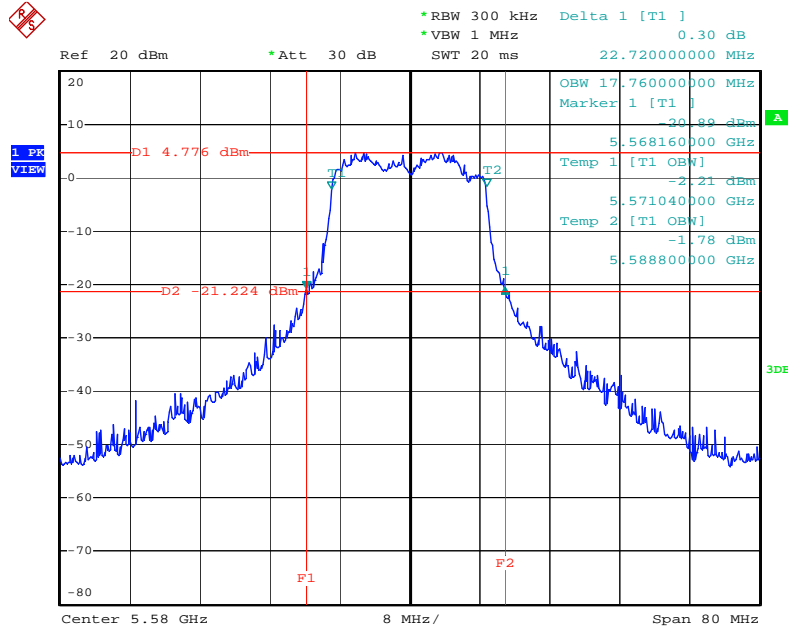

Date: 4.JUL.2009 13:44:15

26 dB Bandwidth Plot on Configuration Drafft n MCS0 20MHz Ant. 3-1 + Ant. 3-2 + Ant. 3-3 / 5700 MHz

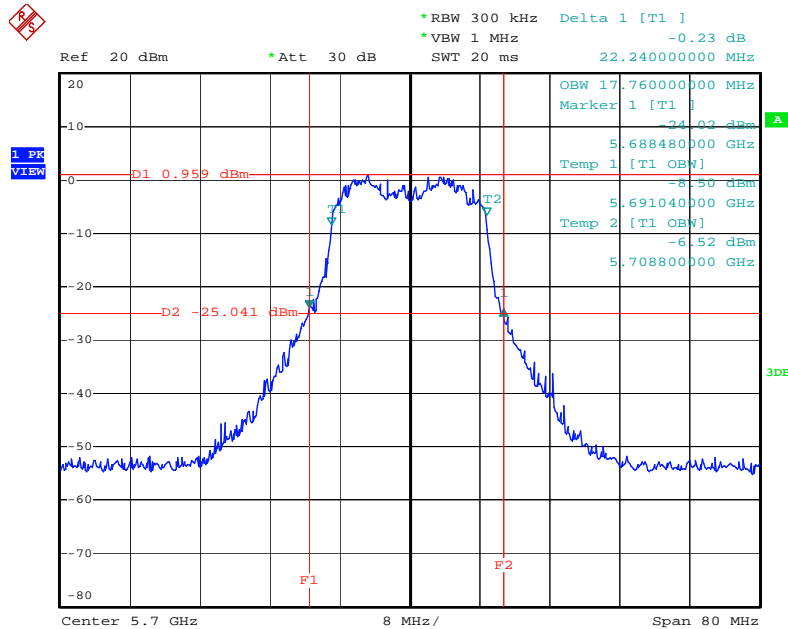

Date: 4.JUL.2009 13:45:47

26 dB Bandwidth Plot on Configuration Drafft n MCS0 40MHz Ant. 3-1 + Ant. 3-2 + Ant. 3-3 / 5270 MHz

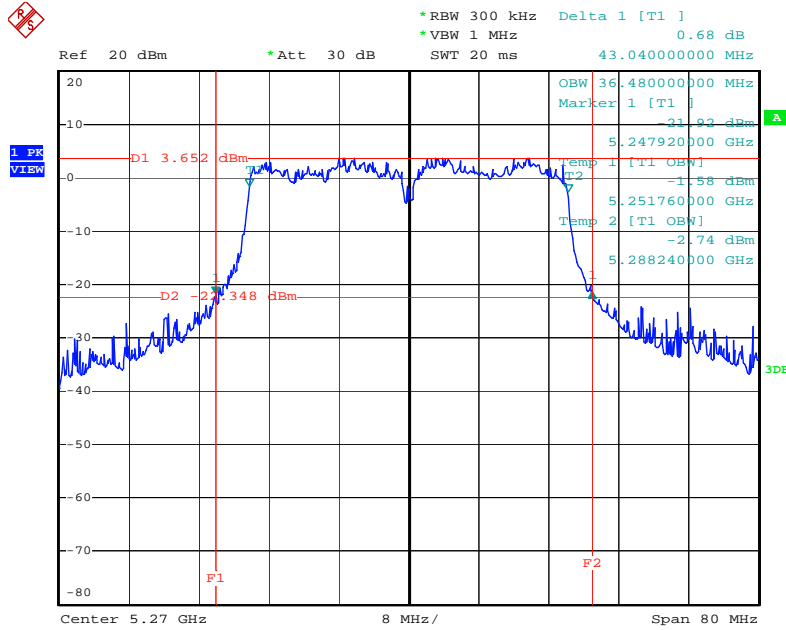

Date: 4.JUL.2009 13:50:33

26 dB Bandwidth Plot on Configuration Drafft n MCS0 40MHz Ant. 3-1 + Ant. 3-2 + Ant. 3-3 / 5310 MHz

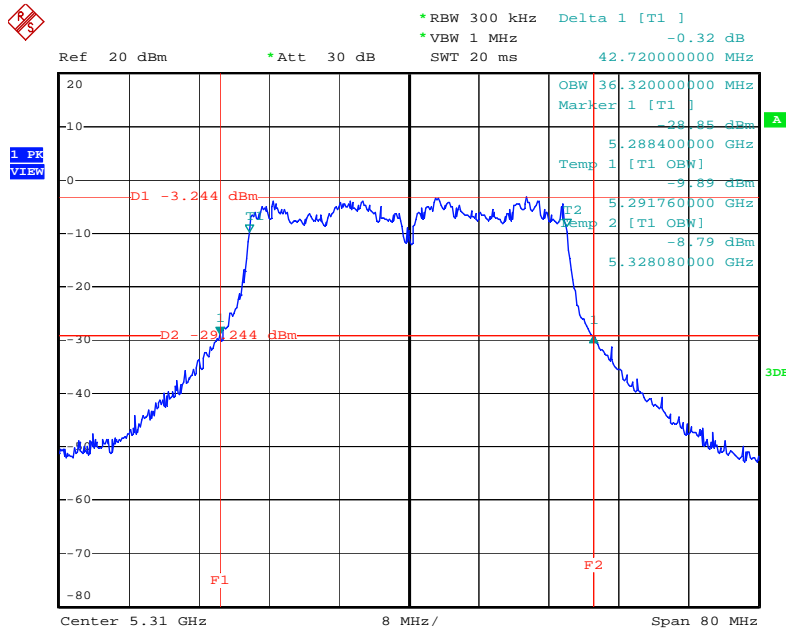

Date: 4.JUL.2009 13:51:28

26 dB Bandwidth Plot on Configuration Drafft n MCS0 40MHz Ant. 3-1 + Ant. 3-2 + Ant. 3-3 / 5510MHz

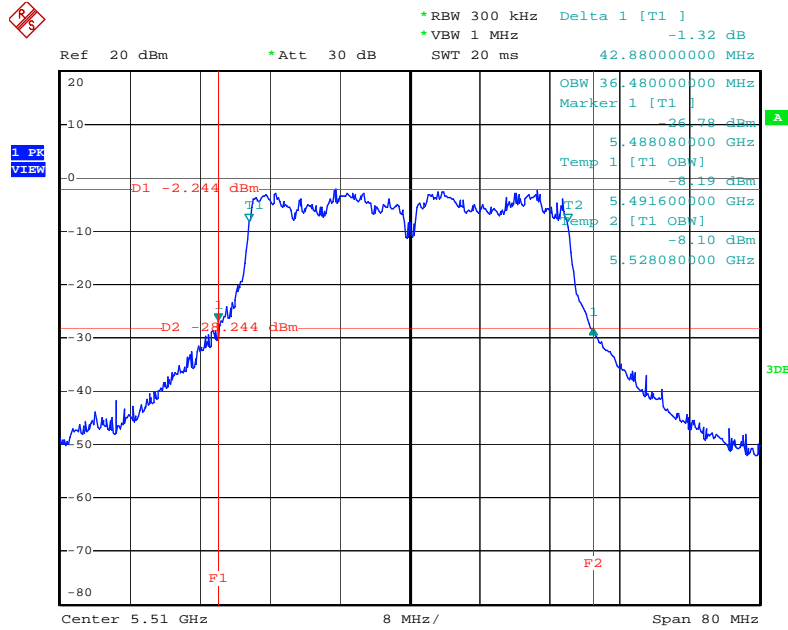

Date: 4.JUL.2009 13:52:50

26 dB Bandwidth Plot on Configuration Drafft n MCS0 40MHz Ant. 3-1 + Ant. 3-2 + Ant. 3-3 / 5550 MHz

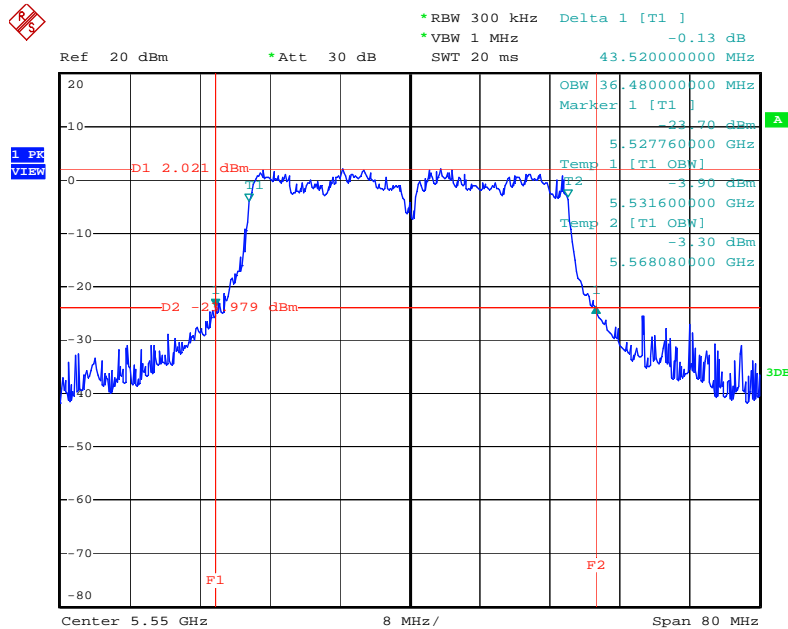

Date: 4.JUL.2009 13:53:52

26 dB Bandwidth Plot on Configuration Drafft n MCS0 40MHz Ant. 3-1 + Ant. 3-2 + Ant. 3-3 / 5670 MHz

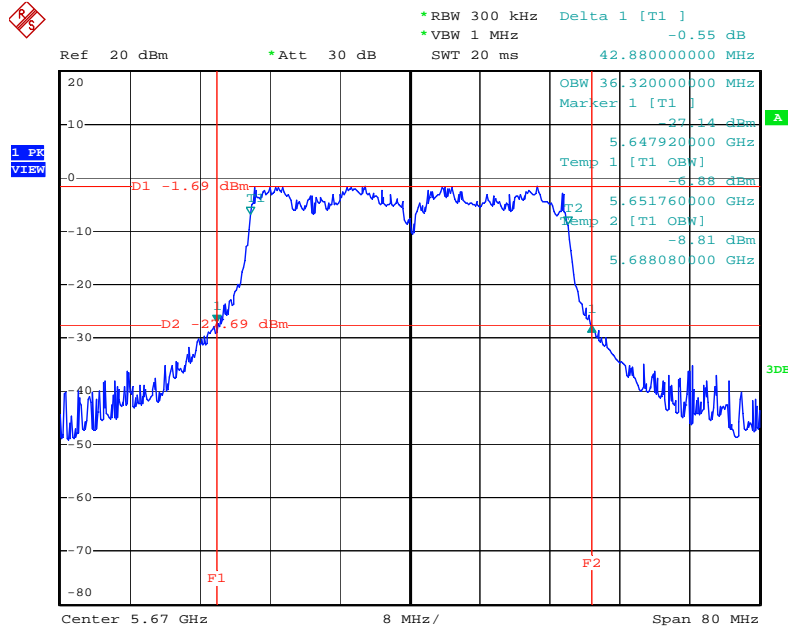

Date: 4.JUL.2009 13:55:12

26 dB Bandwidth Plot on Configuration IEEE 802.11a Ant. 3-1 + Ant. 3-2 + Ant. 3-3 / 5260 MHz

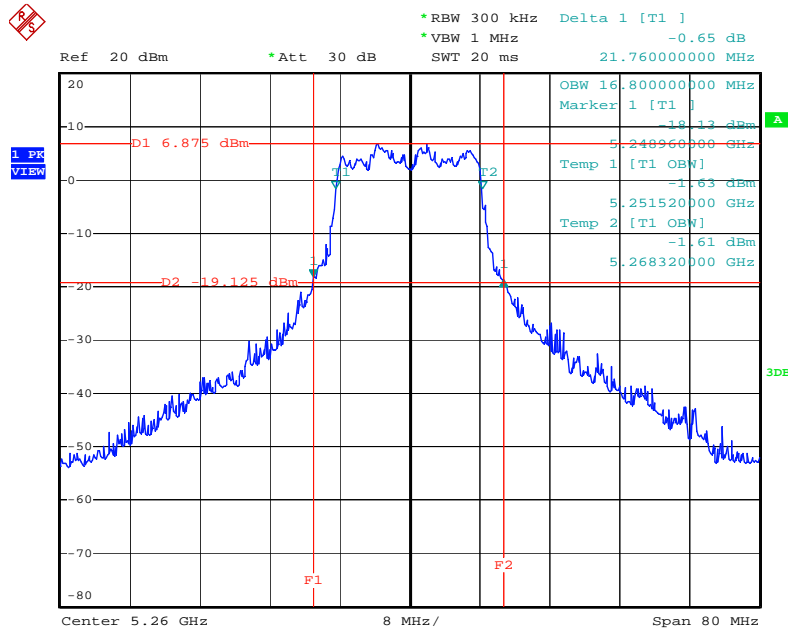

Date: 4.JUL.2009 12:25:08

26 dB Bandwidth Plot on Configuration IEEE 802.11a Ant. 3-1 + Ant. 3-2 + Ant. 3-3 / 5300 MHz

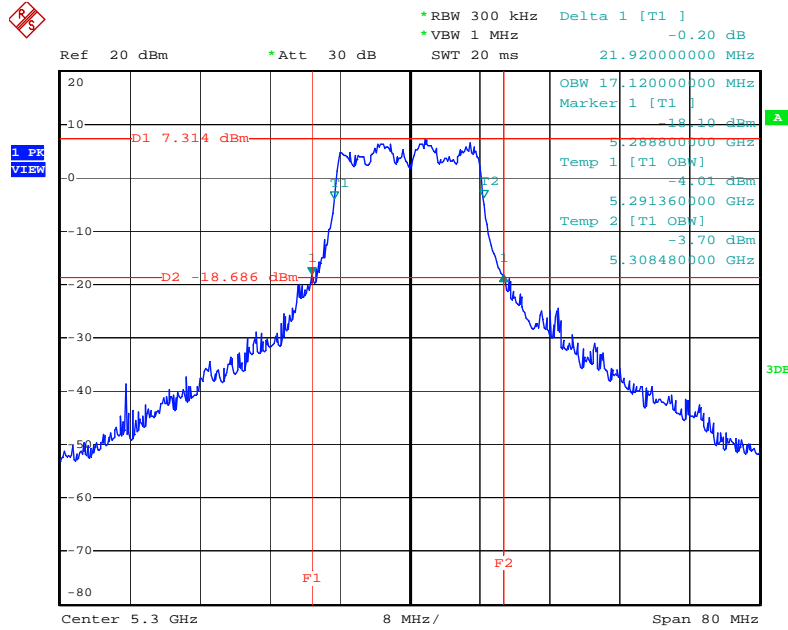

Date: 4.JUL.2009 12:35:24

26 dB Bandwidth Plot on Configuration IEEE 802.11a Ant. 3-1 + Ant. 3-2 + Ant. 3-3 / 5320 MHz

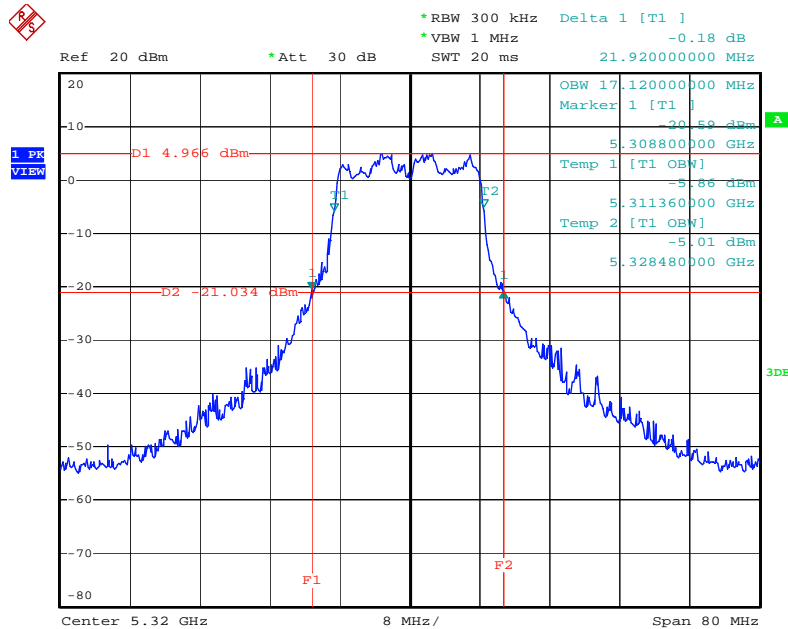

Date: 4.JUL.2009 12:42:54

26 dB Bandwidth Plot on Configuration IEEE 802.11a Ant. 3-1 + Ant. 3-2 + Ant. 3-3 / 5500 MHz

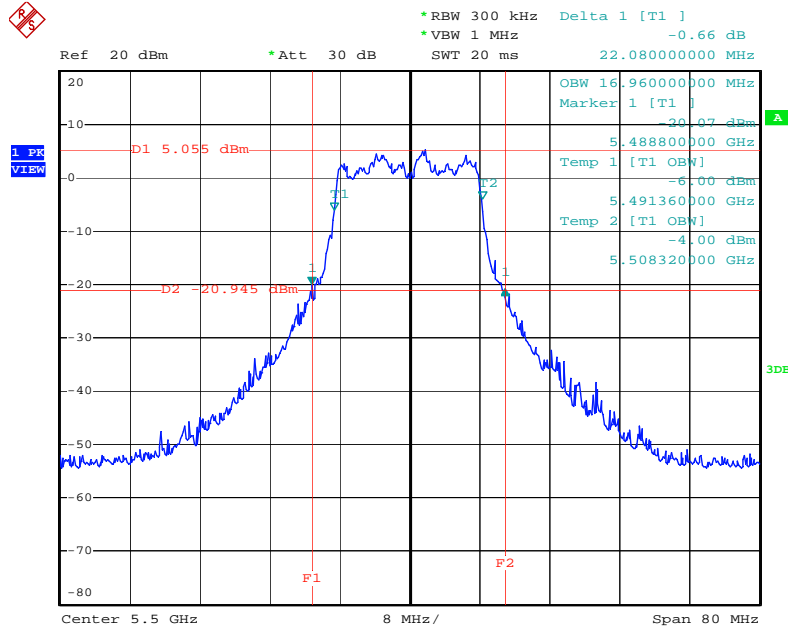

Date: 4.JUL.2009 13:28:00

26 dB Bandwidth Plot on Configuration IEEE 802.11a Ant. 3-1 + Ant. 3-2 + Ant. 3-3 / 5580 MHz

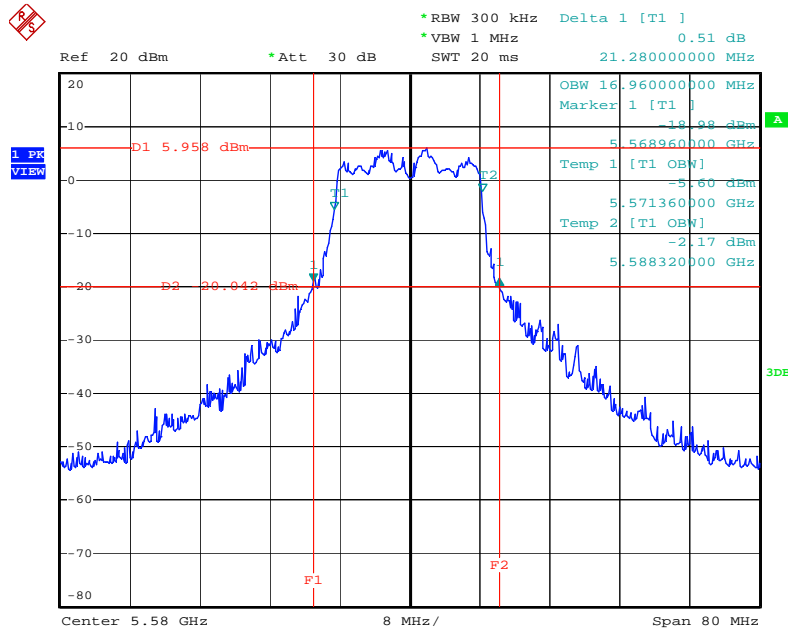

Date: 4.JUL.2009 13:30:33

26 dB Bandwidth Plot on Configuration IEEE 802.11a Ant. 3-1 + Ant. 3-2 + Ant. 3-3 / 5700 MHz

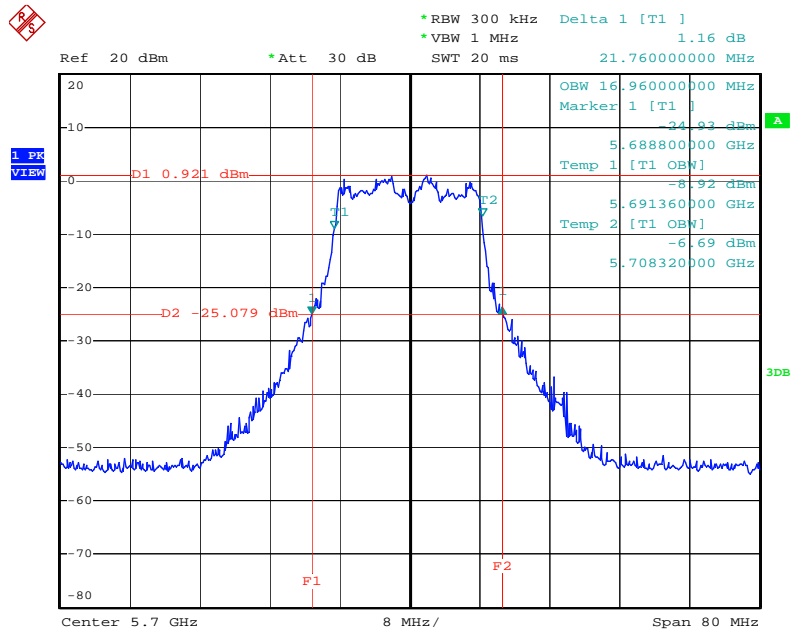

Date: 4.JUL.2009 13:31:45

<For Antenna 4>:

26 dB Bandwidth Plot on Configuration Drafft n MCS0 20MHz Ant. 4-1 + Ant. 4-3 / 5260 MHz

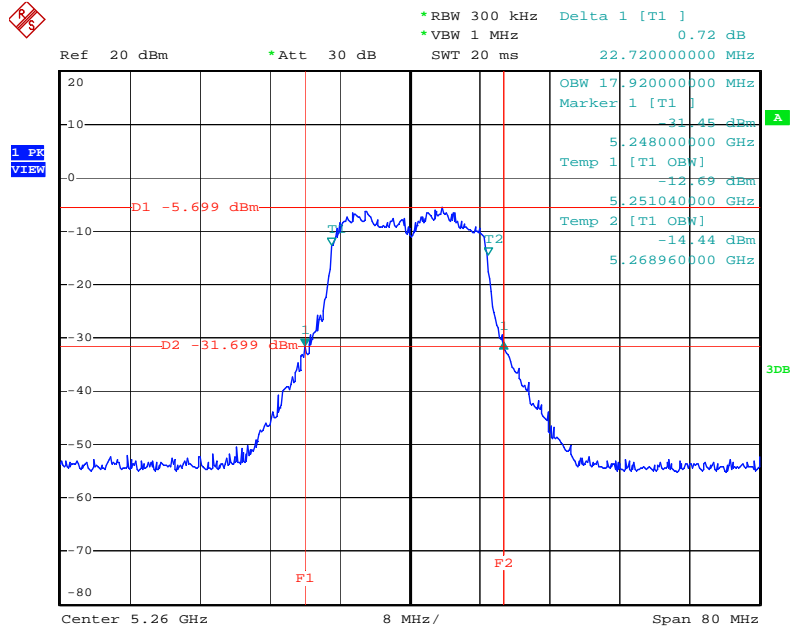

Date: 4.JUL.2009 14:41:47

26 dB Bandwidth Plot on Configuration Drafft n MCS0 20MHz Ant. 4-1 + Ant. 4-3 / 5300 MHz

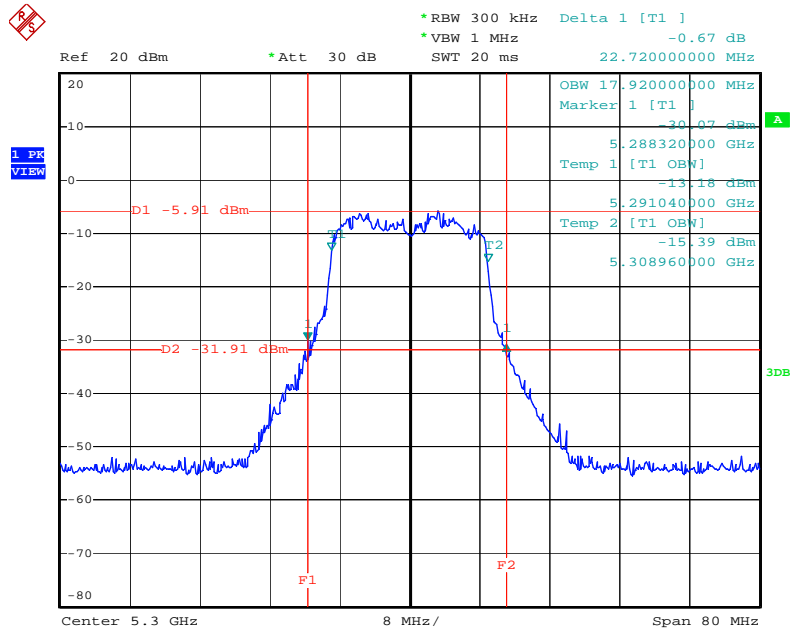

Date: 4.JUL.2009 14:33:26

26 dB Bandwidth Plot on Configuration Drafft n MCS0 20MHz Ant. 4-1 + Ant. 4-3 / 5320 MHz

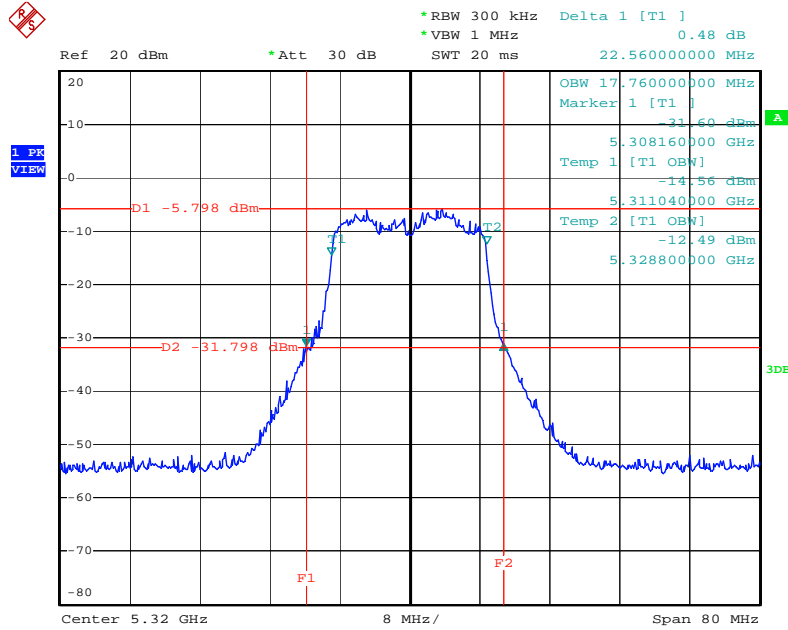

Date: 4.JUL.2009 14:36:51

26 dB Bandwidth Plot on Configuration Drafft n MCS0 20MHz Ant. 4-1 + Ant. 4-3 / 5500 MHz

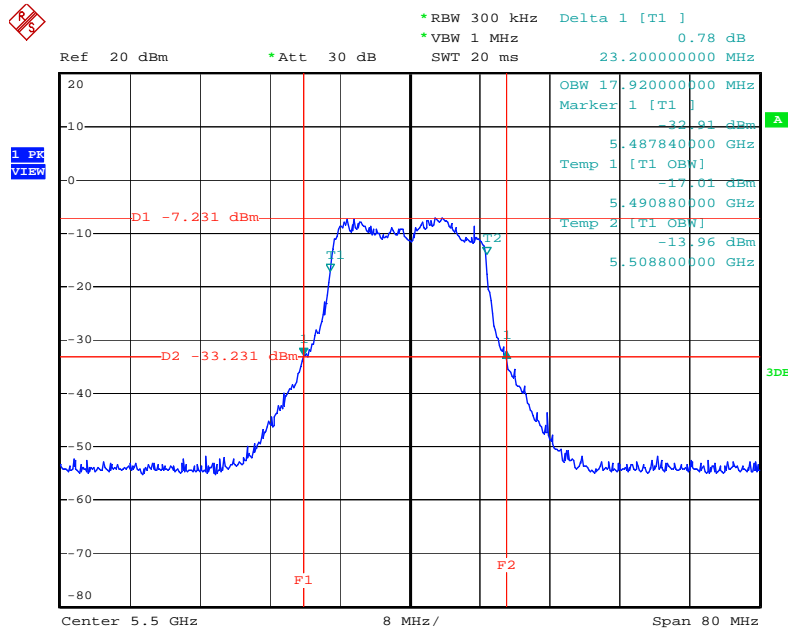

Date: 4.JUL.2009 14:38:26

26 dB Bandwidth Plot on Configuration Drafft n MCS0 20MHz Ant. 4-1 + Ant. 4-3 / 5580 MHz

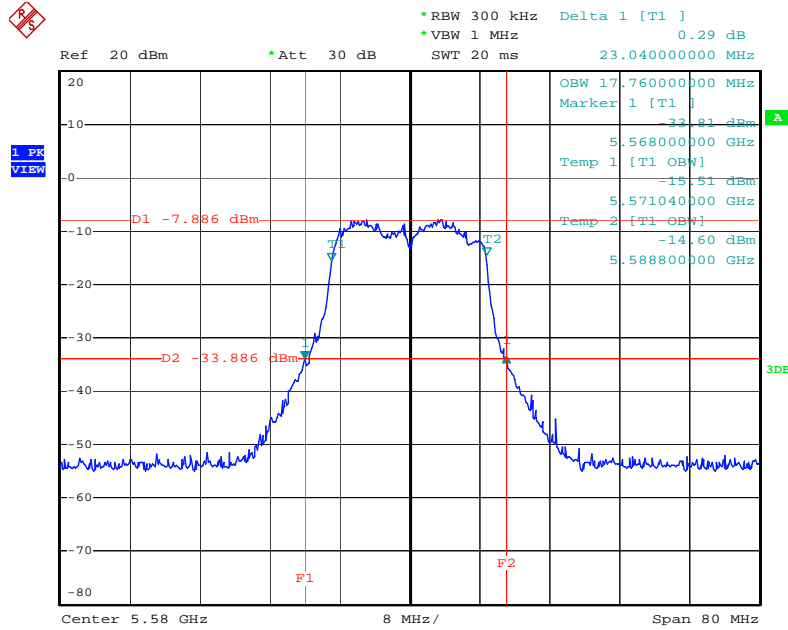

Date: 4.JUL.2009 14:50:10

26 dB Bandwidth Plot on Configuration Drafft n MCS0 20MHz Ant. 4-1 + Ant. 4-3 / 5700 MHz

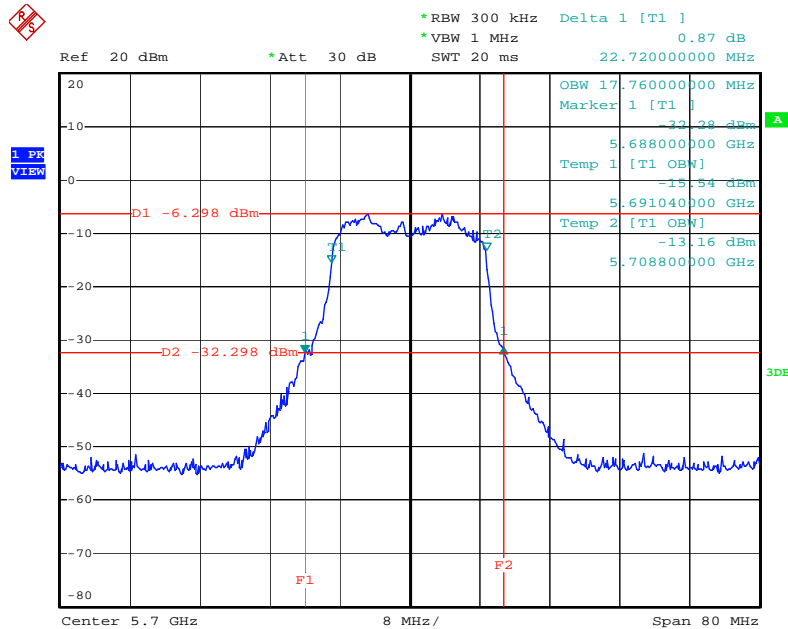

Date: 4.JUL.2009 15:09:36

26 dB Bandwidth Plot on Configuration Drafft n MCS0 40MHz Ant. 4-1 + Ant. 4-3 / 5270 MHz

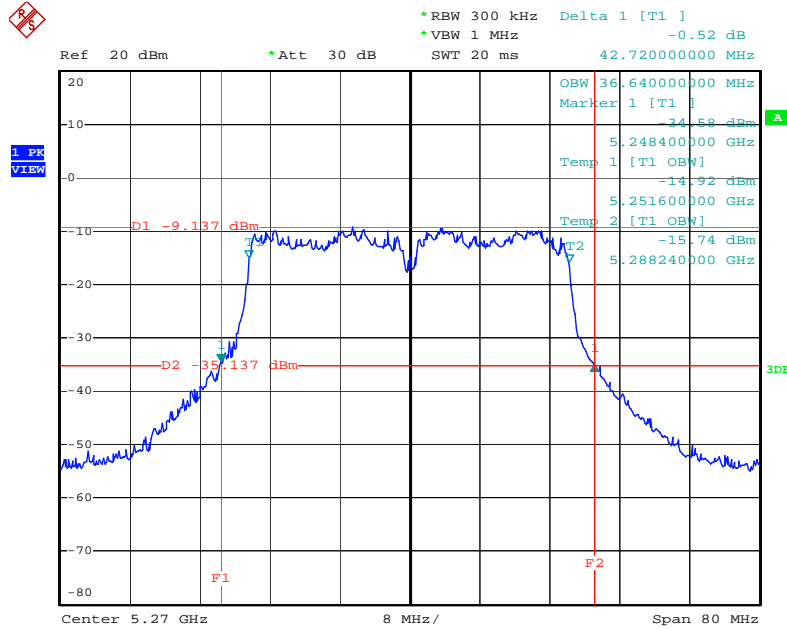

Date: 4.JUL.2009 14:42:57

26 dB Bandwidth Plot on Configuration Drafft n MCS0 40MHz Ant. 4-1 + Ant. 4-3 / 5310 MHz

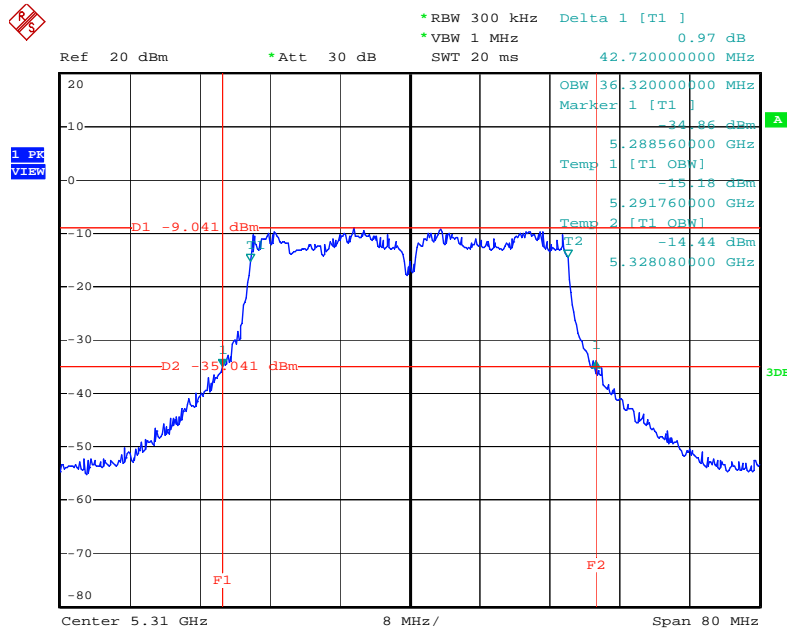

Date: 4.JUL.2009 14:44:19

26 dB Bandwidth Plot on Configuration Drafft n MCS0 40MHz Ant. 4-1 + Ant. 4-3 / 5510MHz

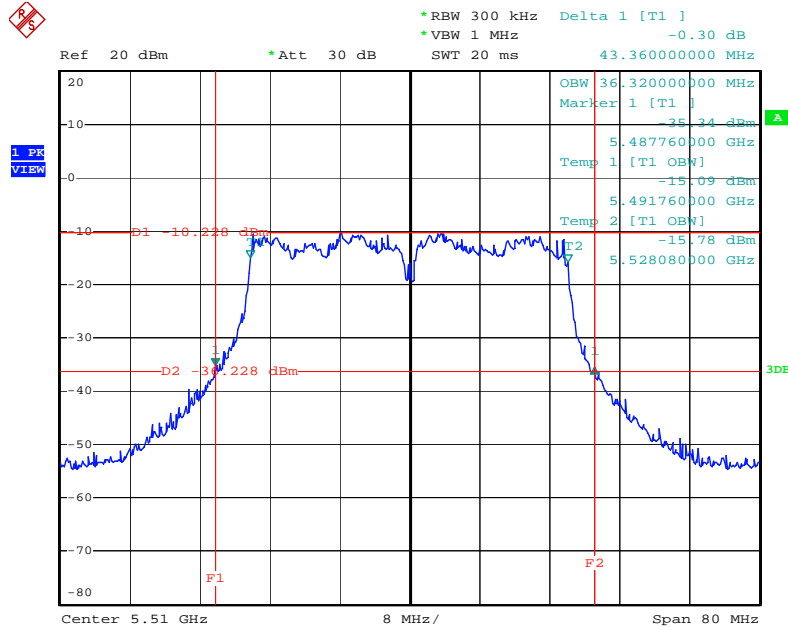

Date: 4.JUL.2009 14:45:37

26 dB Bandwidth Plot on Configuration Drafft n MCS0 40MHz Ant. 4-1 + Ant. 4-3 / 5550 MHz

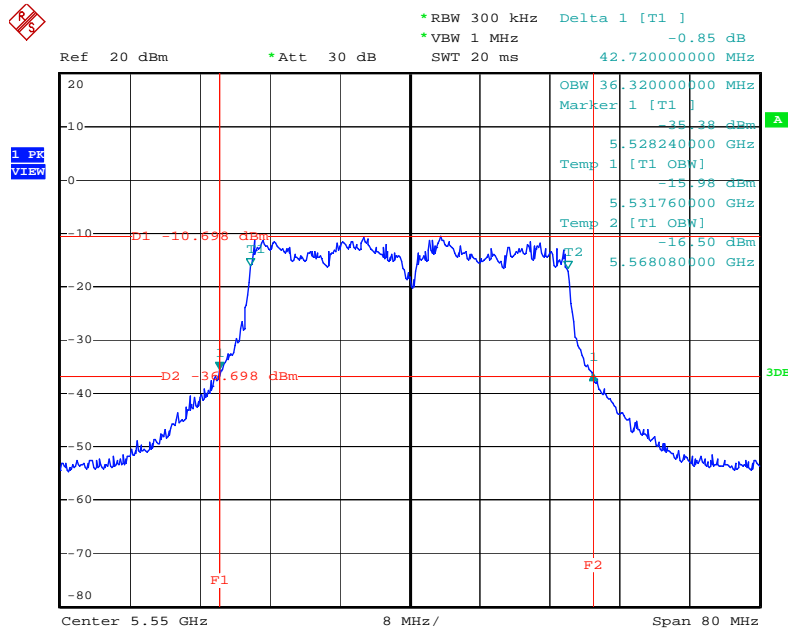

Date: 4.JUL.2009 14:46:39

26 dB Bandwidth Plot on Configuration Draft n MCS0 40MHz Ant. 4-1 + Ant. 4-3 / 5670 MHz

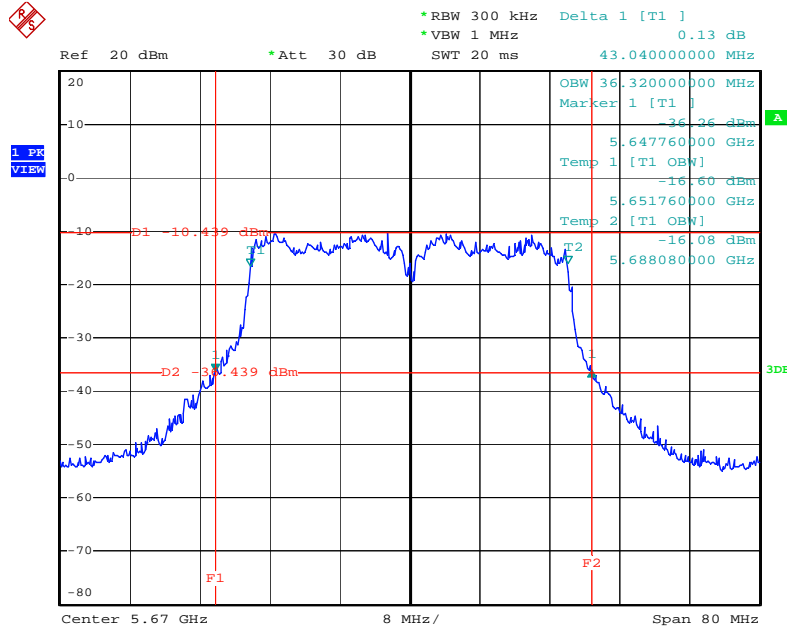

Date: 4.JUL.2009 14:47:45

26 dB Bandwidth Plot on Configuration IEEE 802.11a Ant. 4-1 + Ant. 4-3 / 5260 MHz

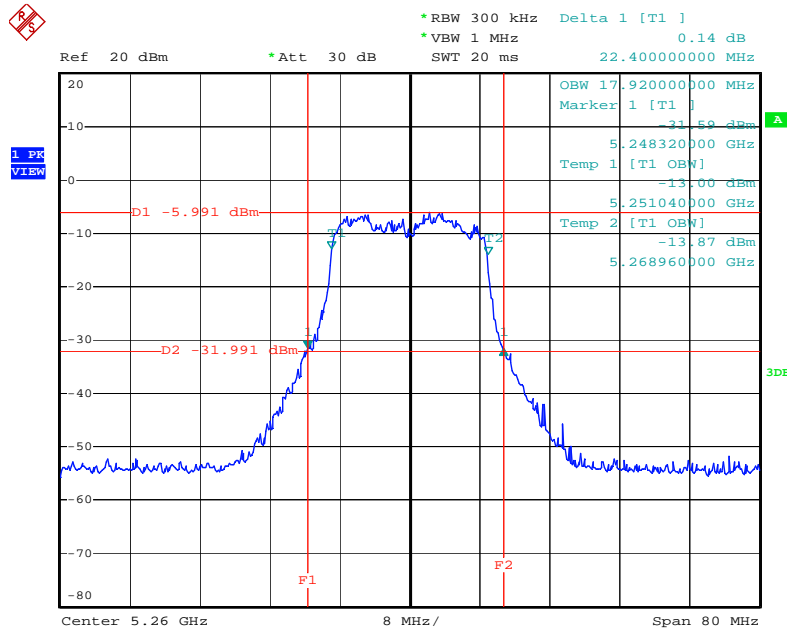

Date: 4.JUL.2009 14:31:59

26 dB Bandwidth Plot on Configuration IEEE 802.11a Ant. 4-1 + Ant. 4-3 / 5300 MHz

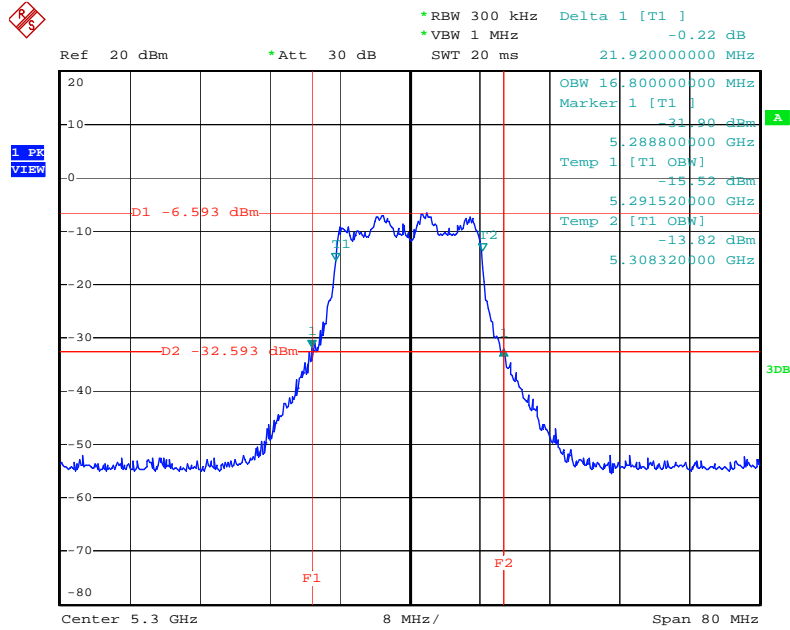

Date: 4.JUL.2009 12:33:32

26 dB Bandwidth Plot on Configuration IEEE 802.11a Ant. 4-1 + Ant. 4-3 / 5320 MHz

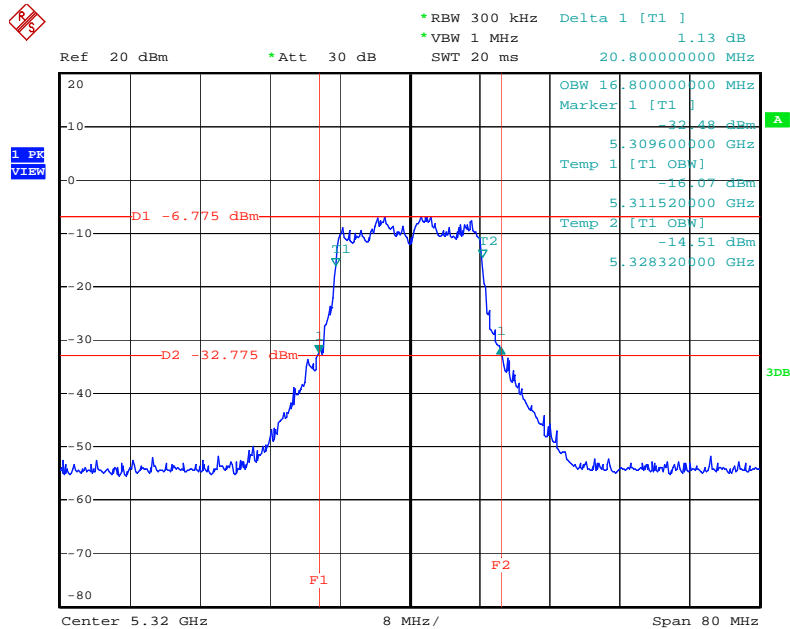

Date: 4.JUL.2009 12:43:46

26 dB Bandwidth Plot on Configuration IEEE 802.11a Ant. 4-1 + Ant. 4-3 / 5500 MHz

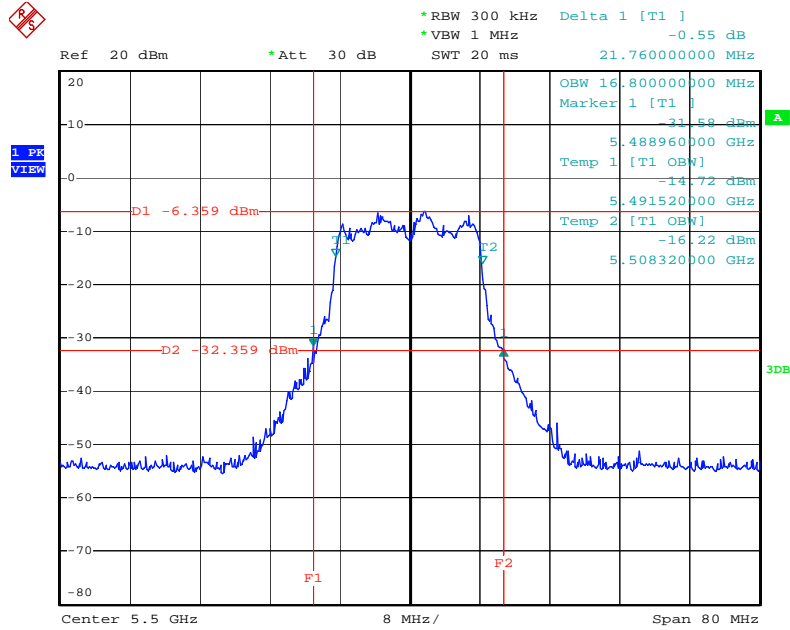

Date: 4.JUL.2009 14:03:13

26 dB Bandwidth Plot on Configuration IEEE 802.11a Ant. 4-1 + Ant. 4-3 / 5580 MHz

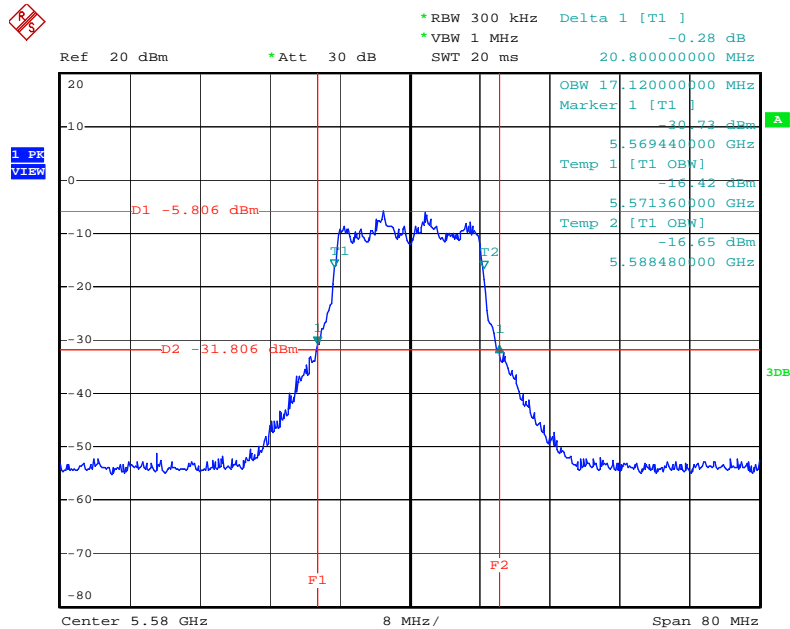

Date: 4.JUL.2009 14:05:27

26 dB Bandwidth Plot on Configuration IEEE 802.11a Ant. 4-1 + Ant. 4-3 / 5700 MHz

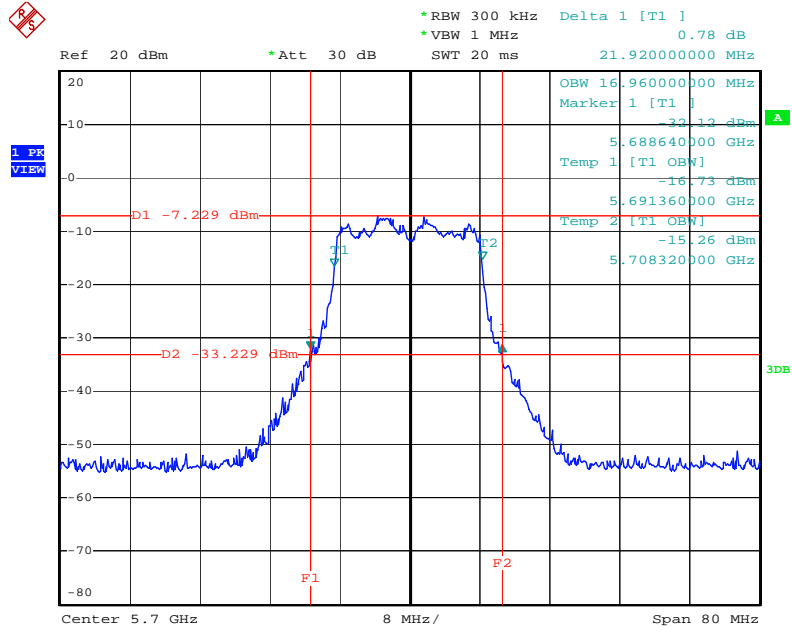

Date: 4.JUL.2009 14:07:11

4.3. Maximum Conducted Output Power Measurement

4.3.1. Limit

For the band 5.15~5.25 GHz, the maximum conducted output power over the frequency band of operation shall not exceed the lesser of 50 mW (17dBm) or $4 \text{ dBm} + 10\log B$, where B is the 26 dB emissions bandwidth in MHz. If transmitting antennas of directional gain greater than 6 dBi are used, the peak output power and power density from the intentional radiator shall be reduced by the amount in dB that the directional gain of the antenna exceeds 6 dBi.

For the 5.25-5.35 GHz and 5.470-5.725 GHz bands, the maximum conducted output power over the frequency bands of operation shall not exceed the lesser of 250 mW (24dBm) or $11 \text{ dBm} + 10\log B$. If transmitting antennas of directional gain greater than 6 dBi are used, the peak output power and power density from the intentional radiator shall be reduced by the amount in dB that the directional gain of the antenna exceeds 6 dBi.

For the band 5.725-5.825 GHz, the maximum conducted output power over the frequency band of operation shall not exceed the lesser of 1 W (30dBm) or $17 \text{ dBm} + 10\log B$. If transmitting antennas of directional gain greater than 6 dBi are used, the peak output power and power density from the intentional radiator shall be reduced by the amount in dB that the directional gain of the antenna exceeds 6 dBi. However, fixed point-to-point U-NII devices operating in this band may employ transmitting antennas with directional gain up to 23 dBi without any corresponding reduction in the transmitter peak output power and peak power spectral density. For fixed, point-to-point U-NII transmitters that employ a directional antenna gain greater than 23 dBi, a 1 dB reduction in peak transmitter power and peak power spectral density for each 1 dB of antenna gain in excess of 23 dBi would be required.

4.3.2. Measuring Instruments and Setting

Please refer to section 5 of equipments list in this report. The following table is the setting of the spectrum analyzer.

Spectrum Parameter	Setting
Attenuation	Auto
Span Frequency	Encompass the entire emissions bandwidth (EBW) of the signal
RB	1000 kHz
VB	3000 kHz
Detector	RMS
Trace	MAX HOLD
Sweep Time	Auto

4.3.3. Test Procedures

1. The transmitter output (antenna port) was connected to the spectrum analyzer.
2. Test was performed in accordance with FCC Public Notice DA 02-2138, August 30, 2002.
3. When measuring maximum conducted output power with multiple antenna systems, add every result of the values by mathematic formula.

4.3.4. Test Setup Layout

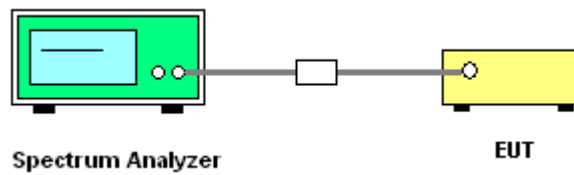

4.3.5. Test Deviation

There is no deviation with the original standard.

4.3.6. EUT Operation during Test

The EUT was programmed to be in continuously transmitting mode.

4.3.7. Test Result of Maximum Conducted Output Power

<For Antenna 1>:

Temperature	21°C	Humidity	56%
Test Engineer	Sam Chen	Configurations	Draft n / Antenna 1

Configuration Draft n MCS0 20MHz Ant. 1-1

Channel	Frequency	Conducted Power (dBm)	Max. Limit (dBm)	Result
52	5260 MHz	17.23	22.00	Complies
60	5300 MHz	17.45	22.00	Complies
64	5320 MHz	13.40	22.00	Complies
100	5500 MHz	12.83	22.00	Complies
116	5580 MHz	16.60	22.00	Complies
140	5700 MHz	13.01	22.00	Complies

Configuration Draft n MCS0 20MHz Ant. 1-2

Channel	Frequency	Conducted Power (dBm)	Max. Limit (dBm)	Result
52	5260 MHz	16.31	22.00	Complies
60	5300 MHz	16.21	22.00	Complies
64	5320 MHz	12.31	22.00	Complies
100	5500 MHz	12.45	22.00	Complies
116	5580 MHz	16.07	22.00	Complies
140	5700 MHz	11.02	22.00	Complies

Configuration Draft n MCS0 20MHz Ant. 1-3

Channel	Frequency	Conducted Power (dBm)	Max. Limit (dBm)	Result
52	5260 MHz	16.73	22.00	Complies
60	5300 MHz	17.20	22.00	Complies
64	5320 MHz	12.27	22.00	Complies
100	5500 MHz	14.20	22.00	Complies
116	5580 MHz	16.01	22.00	Complies
140	5700 MHz	12.41	22.00	Complies

Configuration Draft n MCS0 20MHz Ant. 1-1 + Ant. 1-2 + Ant. 1-3

Channel	Frequency	Conducted Power (dBm)	Max. Limit (dBm)	Result
52	5260 MHz	21.54	22.00	Complies
60	5300 MHz	21.76	22.00	Complies
64	5320 MHz	17.46	22.00	Complies
100	5500 MHz	18.00	22.00	Complies
116	5580 MHz	21.01	22.00	Complies
140	5700 MHz	17.00	22.00	Complies

Configuration Draft n MCS0 40MHz Ant. 1-1

Channel	Frequency	Conducted Power (dBm)	Max. Limit (dBm)	Result
54	5270 MHz	16.78	22.00	Complies
62	5310 MHz	12.01	22.00	Complies
102	5510MHz	10.54	22.00	Complies
110	5550 MHz	15.45	22.00	Complies
134	5670 MHz	14.05	22.00	Complies

Configuration Draft n MCS0 40MHz Ant. 1-2

Channel	Frequency	Conducted Power (dBm)	Max. Limit (dBm)	Result
54	5270 MHz	15.51	22.00	Complies
62	5310 MHz	10.75	22.00	Complies
102	5510MHz	10.12	22.00	Complies
110	5550 MHz	15.34	22.00	Complies
134	5670 MHz	12.00	22.00	Complies

Configuration Draft n MCS0 40MHz Ant. 1-3

Channel	Frequency	Conducted Power (dBm)	Max. Limit (dBm)	Result
54	5270 MHz	15.39	22.00	Complies
62	5310 MHz	11.28	22.00	Complies
102	5510MHz	11.67	22.00	Complies
110	5550 MHz	16.03	22.00	Complies
134	5670 MHz	13.73	22.00	Complies

Configuration Draft n MCS0 40MHz Ant. 1-1 + Ant. 1-2 + Ant. 1-3

Channel	Frequency	Conducted Power (dBm)	Max. Limit (dBm)	Result
54	5270 MHz	20.71	22.00	Complies
62	5310 MHz	16.15	22.00	Complies
102	5510MHz	15.60	22.00	Complies
110	5550 MHz	20.39	22.00	Complies
134	5670 MHz	18.12	22.00	Complies

Temperature	21°C	Humidity	56%
Test Engineer	Sam Chen	Configurations	802.11a / Antenna 1

Configuration IEEE 802.11a Ant. 1-1

Channel	Frequency	Conducted Power (dBm)	Max. Limit (dBm)	Result
52	5260 MHz	17.35	22.00	Complies
60	5300 MHz	17.50	22.00	Complies
64	5320 MHz	14.55	22.00	Complies
100	5500 MHz	13.04	22.00	Complies
116	5580 MHz	16.82	22.00	Complies
140	5700 MHz	13.13	22.00	Complies

Configuration IEEE 802.11a Ant. 1-2

Channel	Frequency	Conducted Power (dBm)	Max. Limit (dBm)	Result
52	5260 MHz	16.31	22.00	Complies
60	5300 MHz	16.25	22.00	Complies
64	5320 MHz	13.05	22.00	Complies
100	5500 MHz	12.64	22.00	Complies
116	5580 MHz	16.04	22.00	Complies
140	5700 MHz	11.04	22.00	Complies

Configuration IEEE 802.11a Ant. 1-3

Channel	Frequency	Conducted Power (dBm)	Max. Limit (dBm)	Result
52	5260 MHz	16.79	22.00	Complies
60	5300 MHz	17.34	22.00	Complies
64	5320 MHz	13.33	22.00	Complies
100	5500 MHz	14.63	22.00	Complies
116	5580 MHz	16.15	22.00	Complies
140	5700 MHz	12.72	22.00	Complies

Configuration IEEE 802.11a Ant. 1-1 + Ant. 1-2 + Ant. 1-3

Channel	Frequency	Conducted Power (dBm)	Max. Limit (dBm)	Result
52	5260 MHz	21.61	22.00	Complies
60	5300 MHz	21.84	22.00	Complies
64	5320 MHz	18.46	22.00	Complies
100	5500 MHz	18.30	22.00	Complies
116	5580 MHz	21.12	22.00	Complies
140	5700 MHz	17.16	22.00	Complies

<For Antenna 2>:

Temperature	21°C	Humidity	56%
Test Engineer	Sam Chen	Configurations	Draft n / Antenna 2

Configuration Draft n MCS0 20MHz Ant. 2-1

Channel	Frequency	Conducted Power (dBm)	Max. Limit (dBm)	Result
52	5260 MHz	11.40	16.50	Complies
60	5300 MHz	12.01	16.50	Complies
64	5320 MHz	12.03	16.50	Complies
100	5500 MHz	11.38	16.50	Complies
116	5580 MHz	12.24	16.50	Complies
140	5700 MHz	10.95	16.50	Complies

Configuration Draft n MCS0 20MHz Ant. 2-2

Channel	Frequency	Conducted Power (dBm)	Max. Limit (dBm)	Result
52	5260 MHz	10.86	16.50	Complies
60	5300 MHz	11.02	16.50	Complies
64	5320 MHz	10.42	16.50	Complies
100	5500 MHz	10.96	16.50	Complies
116	5580 MHz	10.89	16.50	Complies
140	5700 MHz	8.73	16.50	Complies

Configuration Draft n MCS0 20MHz Ant. 2-3

Channel	Frequency	Conducted Power (dBm)	Max. Limit (dBm)	Result
52	5260 MHz	10.56	16.50	Complies
60	5300 MHz	11.20	16.50	Complies
64	5320 MHz	11.01	16.50	Complies
100	5500 MHz	12.25	16.50	Complies
116	5580 MHz	11.35	16.50	Complies
140	5700 MHz	11.11	16.50	Complies

Configuration Draft n MCS0 20MHz Ant. 2-1 + Ant. 2-2 + Ant. 2-3

Channel	Frequency	Conducted Power (dBm)	Max. Limit (dBm)	Result
52	5260 MHz	15.73	16.50	Complies
60	5300 MHz	16.20	16.50	Complies
64	5320 MHz	15.98	16.50	Complies
100	5500 MHz	16.33	16.50	Complies
116	5580 MHz	16.30	16.50	Complies
140	5700 MHz	15.16	16.50	Complies

Configuration Draft n MCS0 40MHz Ant. 2-1

Channel	Frequency	Conducted Power (dBm)	Max. Limit (dBm)	Result
54	5270 MHz	11.92	16.50	Complies
62	5310 MHz	9.26	16.50	Complies
102	5510MHz	7.45	16.50	Complies
110	5550 MHz	11.07	16.50	Complies
134	5670 MHz	11.97	16.50	Complies

Configuration Draft n MCS0 40MHz Ant. 2-2

Channel	Frequency	Conducted Power (dBm)	Max. Limit (dBm)	Result
54	5270 MHz	11.58	16.50	Complies
62	5310 MHz	8.42	16.50	Complies
102	5510MHz	7.02	16.50	Complies
110	5550 MHz	10.74	16.50	Complies
134	5670 MHz	9.98	16.50	Complies

Configuration Draft n MCS0 40MHz Ant. 2-3

Channel	Frequency	Conducted Power (dBm)	Max. Limit (dBm)	Result
54	5270 MHz	11.63	16.50	Complies
62	5310 MHz	8.85	16.50	Complies
102	5510MHz	8.30	16.50	Complies
110	5550 MHz	11.56	16.50	Complies
134	5670 MHz	11.69	16.50	Complies

Configuration Draft n MCS0 40MHz Ant. 2-1 + Ant. 2-2 + Ant. 2-3

Channel	Frequency	Conducted Power (dBm)	Max. Limit (dBm)	Result
54	5270 MHz	16.48	16.50	Complies
62	5310 MHz	13.63	16.50	Complies
102	5510MHz	12.39	16.50	Complies
110	5550 MHz	15.91	16.50	Complies
134	5670 MHz	16.07	16.50	Complies

Temperature	21°C	Humidity	56%
Test Engineer	Sam Chen	Configurations	802.11a / Antenna 2

Configuration IEEE 802.11a Ant. 2-1

Channel	Frequency	Conducted Power (dBm)	Max. Limit (dBm)	Result
52	5260 MHz	11.52	16.50	Complies
60	5300 MHz	12.01	16.50	Complies
64	5320 MHz	12.04	16.50	Complies
100	5500 MHz	11.51	16.50	Complies
116	5580 MHz	12.33	16.50	Complies
140	5700 MHz	11.03	16.50	Complies

Configuration IEEE 802.11a Ant. 2-2

Channel	Frequency	Conducted Power (dBm)	Max. Limit (dBm)	Result
52	5260 MHz	11.12	16.50	Complies
60	5300 MHz	11.02	16.50	Complies
64	5320 MHz	10.41	16.50	Complies
100	5500 MHz	10.86	16.50	Complies
116	5580 MHz	10.82	16.50	Complies
140	5700 MHz	8.67	16.50	Complies

Configuration IEEE 802.11a Ant. 2-3

Channel	Frequency	Conducted Power (dBm)	Max. Limit (dBm)	Result
52	5260 MHz	10.70	16.50	Complies
60	5300 MHz	11.23	16.50	Complies
64	5320 MHz	11.11	16.50	Complies
100	5500 MHz	12.47	16.50	Complies
116	5580 MHz	11.44	16.50	Complies
140	5700 MHz	11.11	16.50	Complies

Configuration IEEE 802.11a Ant. 2-1 + Ant. 2-2 + Ant. 2-3

Channel	Frequency	Conducted Power (dBm)	Max. Limit (dBm)	Result
52	5260 MHz	15.90	16.50	Complies
60	5300 MHz	16.21	16.50	Complies
64	5320 MHz	16.01	16.50	Complies
100	5500 MHz	16.44	16.50	Complies
116	5580 MHz	16.35	16.50	Complies
140	5700 MHz	15.18	16.50	Complies

<For Antenna 3>:

Temperature	21°C	Humidity	56%
Test Engineer	Sam Chen	Configurations	Draft n / Antenna 3

Configuration Draft n MCS0 20MHz Ant. 3-1

Channel	Frequency	Conducted Power (dBm)	Max. Limit (dBm)	Result
52	5260 MHz	14.55	19.30	Complies
60	5300 MHz	15.07	19.30	Complies
64	5320 MHz	12.03	19.30	Complies
100	5500 MHz	11.38	19.30	Complies
116	5580 MHz	14.26	19.30	Complies
140	5700 MHz	9.89	19.30	Complies

Configuration Draft n MCS0 20MHz Ant. 3-2

Channel	Frequency	Conducted Power (dBm)	Max. Limit (dBm)	Result
52	5260 MHz	13.73	19.30	Complies
60	5300 MHz	13.54	19.30	Complies
64	5320 MHz	10.42	19.30	Complies
100	5500 MHz	10.96	19.30	Complies
116	5580 MHz	12.93	19.30	Complies
140	5700 MHz	7.89	19.30	Complies

Configuration Draft n MCS0 20MHz Ant. 3-3

Channel	Frequency	Conducted Power (dBm)	Max. Limit (dBm)	Result
52	5260 MHz	13.00	19.30	Complies
60	5300 MHz	14.39	19.30	Complies
64	5320 MHz	11.01	19.30	Complies
100	5500 MHz	12.25	19.30	Complies
116	5580 MHz	13.60	19.30	Complies
140	5700 MHz	9.62	19.30	Complies

Configuration Draft n MCS0 20MHz Ant. 3-1 + Ant. 3-2 + Ant. 3-3

Channel	Frequency	Conducted Power (dBm)	Max. Limit (dBm)	Result
52	5260 MHz	18.58	19.30	Complies
60	5300 MHz	19.15	19.30	Complies
64	5320 MHz	15.98	19.30	Complies
100	5500 MHz	16.33	19.30	Complies
116	5580 MHz	18.40	19.30	Complies
140	5700 MHz	13.99	19.30	Complies

Configuration Draft n MCS0 40MHz Ant. 3-1

Channel	Frequency	Conducted Power (dBm)	Max. Limit (dBm)	Result
54	5270 MHz	15.29	19.30	Complies
62	5310 MHz	7.30	19.30	Complies
102	5510MHz	8.86	19.30	Complies
110	5550 MHz	14.02	19.30	Complies
134	5670 MHz	11.03	19.30	Complies

Configuration Draft n MCS0 40MHz Ant. 3-2

Channel	Frequency	Conducted Power (dBm)	Max. Limit (dBm)	Result
54	5270 MHz	13.61	19.30	Complies
62	5310 MHz	5.86	19.30	Complies
102	5510MHz	8.57	19.30	Complies
110	5550 MHz	13.88	19.30	Complies
134	5670 MHz	8.75	19.30	Complies

Configuration Draft n MCS0 40MHz Ant. 3-3

Channel	Frequency	Conducted Power (dBm)	Max. Limit (dBm)	Result
54	5270 MHz	13.41	19.30	Complies
62	5310 MHz	6.47	19.30	Complies
102	5510MHz	9.90	19.30	Complies
110	5550 MHz	13.94	19.30	Complies
134	5670 MHz	10.50	19.30	Complies

Configuration Draft n MCS0 40MHz Ant. 3-1 + Ant. 3-2 + Ant. 3-3

Channel	Frequency	Conducted Power (dBm)	Max. Limit (dBm)	Result
54	5270 MHz	18.96	19.30	Complies
62	5310 MHz	11.35	19.30	Complies
102	5510MHz	13.92	19.30	Complies
110	5550 MHz	18.72	19.30	Complies
134	5670 MHz	14.97	19.30	Complies

Temperature	21°C	Humidity	56%
Test Engineer	Sam Chen	Configurations	802.11a / Antenna 3

Configuration IEEE 802.11a Ant. 3-1

Channel	Frequency	Conducted Power (dBm)	Max. Limit (dBm)	Result
52	5260 MHz	14.43	19.30	Complies
60	5300 MHz	14.71	19.30	Complies
64	5320 MHz	13.09	19.30	Complies
100	5500 MHz	12.42	19.30	Complies
116	5580 MHz	14.22	19.30	Complies
140	5700 MHz	9.82	19.30	Complies

Configuration IEEE 802.11a Ant. 3-2

Channel	Frequency	Conducted Power (dBm)	Max. Limit (dBm)	Result
52	5260 MHz	13.75	19.30	Complies
60	5300 MHz	13.82	19.30	Complies
64	5320 MHz	11.83	19.30	Complies
100	5500 MHz	11.89	19.30	Complies
116	5580 MHz	12.97	19.30	Complies
140	5700 MHz	7.75	19.30	Complies

Configuration IEEE 802.11a Ant. 3-3

Channel	Frequency	Conducted Power (dBm)	Max. Limit (dBm)	Result
52	5260 MHz	13.78	19.30	Complies
60	5300 MHz	14.52	19.30	Complies
64	5320 MHz	12.05	19.30	Complies
100	5500 MHz	13.47	19.30	Complies
116	5580 MHz	13.69	19.30	Complies
140	5700 MHz	9.48	19.30	Complies

Configuration IEEE 802.11a Ant. 3-1 + Ant. 3-2 + Ant. 3-3

Channel	Frequency	Conducted Power (dBm)	Max. Limit (dBm)	Result
52	5260 MHz	18.77	19.30	Complies
60	5300 MHz	19.14	19.30	Complies
64	5320 MHz	17.13	19.30	Complies
100	5500 MHz	17.41	19.30	Complies
116	5580 MHz	18.43	19.30	Complies
140	5700 MHz	13.88	19.30	Complies

<For Antenna 4>:

Temperature	21°C	Humidity	56%
Test Engineer	Sam Chen	Configurations	Draft n / Antenna 4

Configuration Draft n MCS0 20MHz Ant. 4-1

Channel	Frequency	Conducted Power (dBm)	Max. Limit (dBm)	Result
52	5260 MHz	3.91	6.50	Complies
60	5300 MHz	3.85	6.50	Complies
64	5320 MHz	3.47	6.50	Complies
100	5500 MHz	3.25	6.50	Complies
116	5580 MHz	3.41	6.50	Complies
140	5700 MHz	3.20	6.50	Complies

Configuration Draft n MCS0 20MHz Ant. 4-3

Channel	Frequency	Conducted Power (dBm)	Max. Limit (dBm)	Result
52	5260 MHz	2.98	6.50	Complies
60	5300 MHz	2.91	6.50	Complies
64	5320 MHz	2.47	6.50	Complies
100	5500 MHz	2.97	6.50	Complies
116	5580 MHz	2.44	6.50	Complies
140	5700 MHz	2.89	6.50	Complies

Configuration Draft n MCS0 20MHz Ant. 4-1 + Ant. 4-3

Channel	Frequency	Conducted Power (dBm)	Max. Limit (dBm)	Result
52	5260 MHz	6.48	6.50	Complies
60	5300 MHz	6.42	6.50	Complies
64	5320 MHz	6.01	6.50	Complies
100	5500 MHz	6.12	6.50	Complies
116	5580 MHz	5.96	6.50	Complies
140	5700 MHz	6.06	6.50	Complies

Configuration Draft n MCS0 40MHz Ant. 4-1

Channel	Frequency	Conducted Power (dBm)	Max. Limit (dBm)	Result
54	5270 MHz	3.79	6.50	Complies
62	5310 MHz	3.87	6.50	Complies
102	5510MHz	3.52	6.50	Complies
110	5550 MHz	3.51	6.50	Complies
134	5670 MHz	3.61	6.50	Complies

Configuration Draft n MCS0 40MHz Ant. 4-3

Channel	Frequency	Conducted Power (dBm)	Max. Limit (dBm)	Result
54	5270 MHz	3.08	6.50	Complies
62	5310 MHz	3.05	6.50	Complies
102	5510MHz	3.42	6.50	Complies
110	5550 MHz	3.11	6.50	Complies
134	5670 MHz	3.18	6.50	Complies

Configuration Draft n MCS0 40MHz Ant. 4-1 + Ant. 4-3

Channel	Frequency	Conducted Power (dBm)	Max. Limit (dBm)	Result
54	5270 MHz	6.46	6.50	Complies
62	5310 MHz	6.49	6.50	Complies
102	5510MHz	6.48	6.50	Complies
110	5550 MHz	6.32	6.50	Complies
134	5670 MHz	6.41	6.50	Complies

Temperature	21°C	Humidity	56%
Test Engineer	Sam Chen	Configurations	802.11a / Antenna 4

Configuration IEEE 802.11a Ant. 4-1

Channel	Frequency	Conducted Power (dBm)	Max. Limit (dBm)	Result
52	5260 MHz	3.72	6.50	Complies
60	5300 MHz	3.84	6.50	Complies
64	5320 MHz	3.61	6.50	Complies
100	5500 MHz	3.01	6.50	Complies
116	5580 MHz	3.36	6.50	Complies
140	5700 MHz	3.11	6.50	Complies

Configuration IEEE 802.11a Ant. 4-3

Channel	Frequency	Conducted Power (dBm)	Max. Limit (dBm)	Result
52	5260 MHz	3.05	6.50	Complies
60	5300 MHz	2.78	6.50	Complies
64	5320 MHz	2.41	6.50	Complies
100	5500 MHz	3.06	6.50	Complies
116	5580 MHz	2.45	6.50	Complies
140	5700 MHz	2.77	6.50	Complies

Configuration IEEE 802.11a Ant. 4-1 + Ant. 4-3

Channel	Frequency	Conducted Power (dBm)	Max. Limit (dBm)	Result
52	5260 MHz	6.41	6.50	Complies
60	5300 MHz	6.35	6.50	Complies
64	5320 MHz	6.06	6.50	Complies
100	5500 MHz	6.05	6.50	Complies
116	5580 MHz	5.94	6.50	Complies
140	5700 MHz	5.95	6.50	Complies

<For Antenna 1>:

Conducted Output Power Plot on Configuration Draft n MCS0 20MHz Ant. 1-1 / 5260 MHz

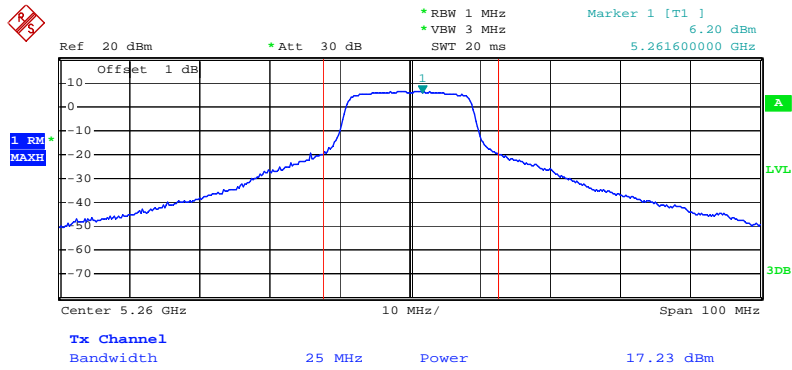

Date: 23.JUN.2009 23:37:35

Conducted Output Power Plot on Configuration Draft n MCS0 20MHz Ant. 1-1 / 5300 MHz

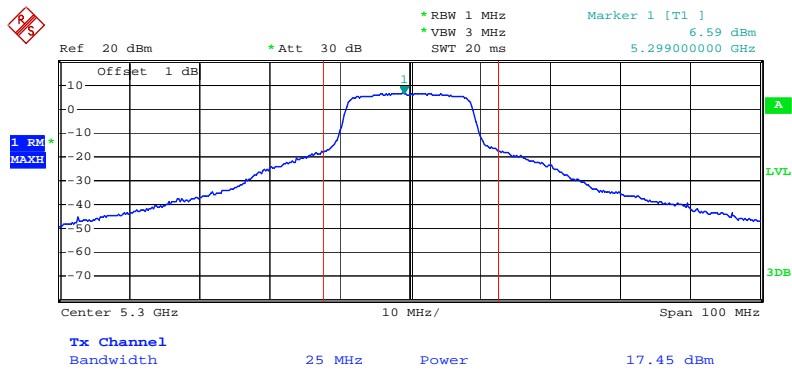

Date: 23.JUN.2009 23:38:35

Conducted Output Power Plot on Configuration Draft n MCS0 20MHz Ant. 1-1 / 5320 MHz

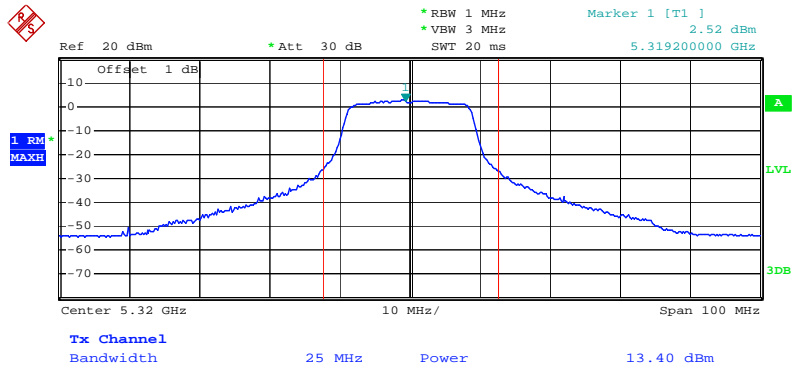

Date: 23.JUN.2009 23:45:13

Conducted Output Power Plot on Configuration Draft n MCS0 20MHz Ant. 1-1 / 5500 MHz

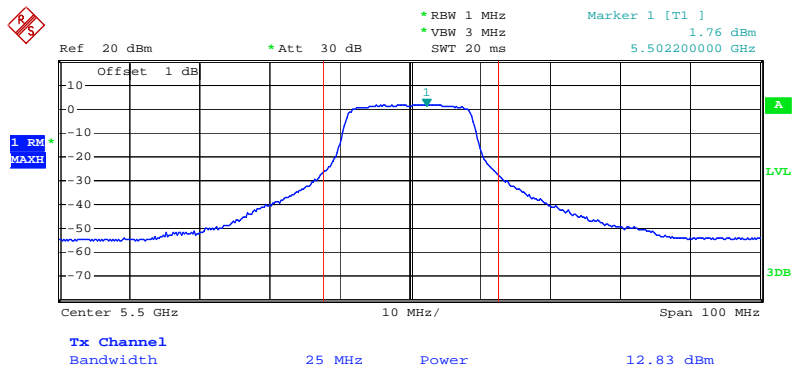

Date: 23.JUN.2009 23:46:36

Conducted Output Power Plot on Configuration Draft n MCS0 20MHz Ant. 1-1 / 5580 MHz

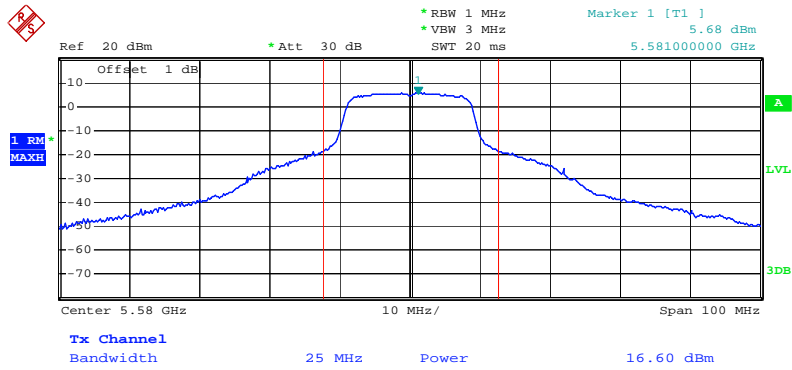

Date: 23.JUN.2009 23:54:11

Conducted Output Power Plot on Configuration Draft n MCS0 20MHz Ant. 1-1 / 5700 MHz

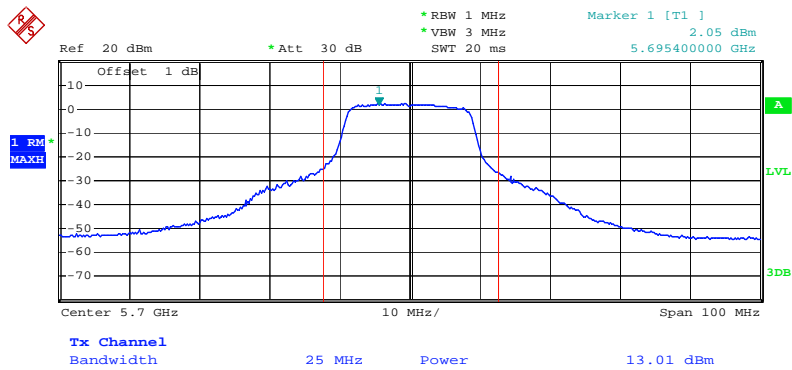

Date: 23.JUN.2009 23:55:37

Conducted Output Power Plot on Configuration Draft n MCS0 20MHz Ant. 1-2 / 5260 MHz

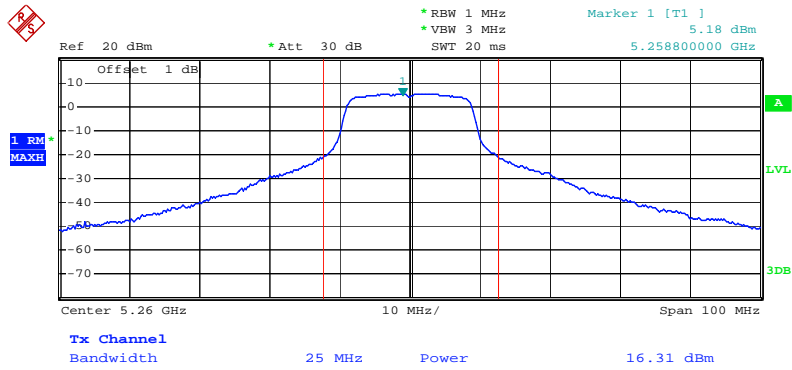

Date: 23.JUN.2009 23:35:48

Conducted Output Power Plot on Configuration Draft n MCS0 20MHz Ant. 1-2 / 5300 MHz

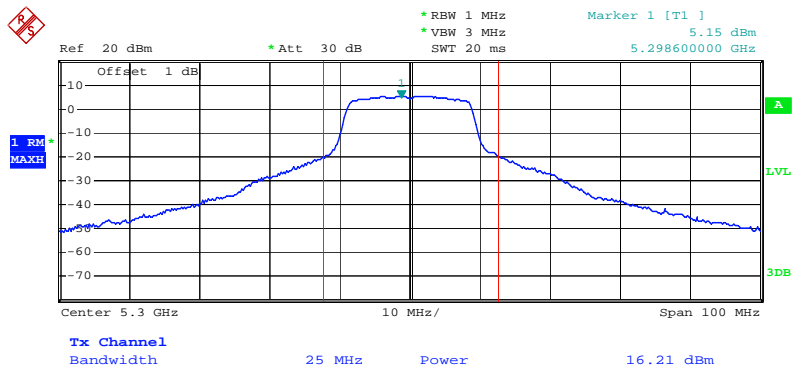

Date: 23.JUN.2009 23:39:45

Conducted Output Power Plot on Configuration Draft n MCS0 20MHz Ant. 1-2 / 5320 MHz

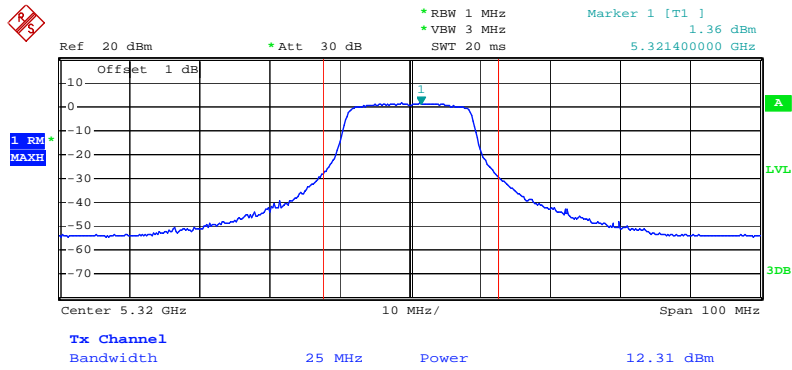

Date: 23.JUN.2009 23:43:59

Conducted Output Power Plot on Configuration Draft n MCS0 20MHz Ant. 1-2 / 5500 MHz

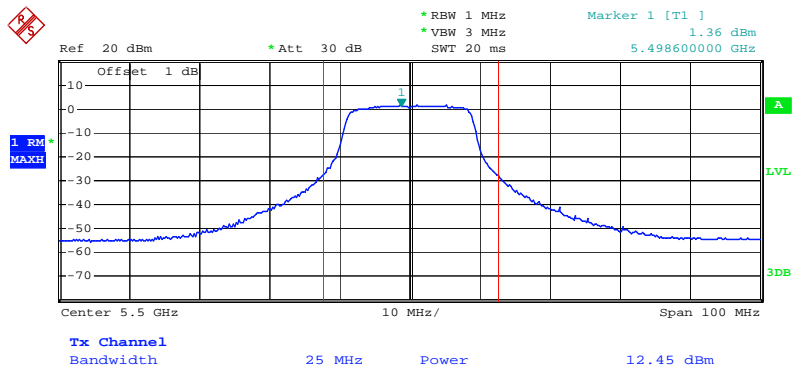

Date: 23.JUN.2009 23:47:44

Conducted Output Power Plot on Configuration Draft n MCS0 20MHz Ant. 1-2 / 5580 MHz

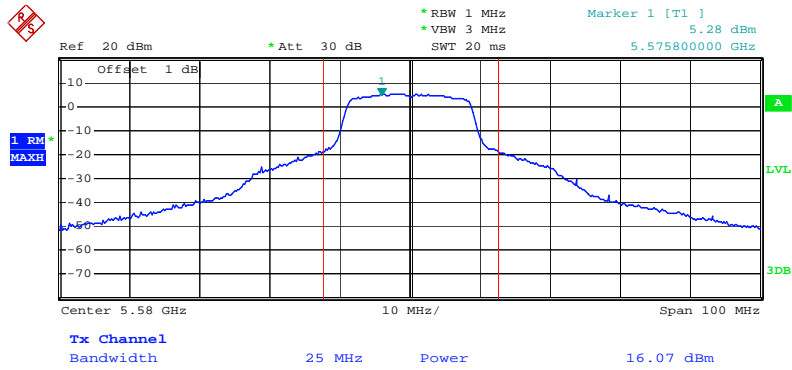

Date: 23.JUN.2009 23:52:23

Conducted Output Power Plot on Configuration Draft n MCS0 20MHz Ant. 1-2 / 5700 MHz

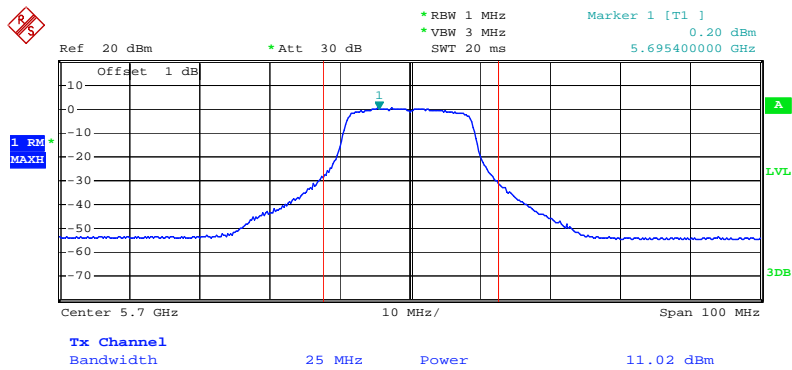

Date: 23.JUN.2009 23:57:21

Conducted Output Power Plot on Configuration Draft n MCS0 20MHz Ant. 1-3 / 5260 MHz

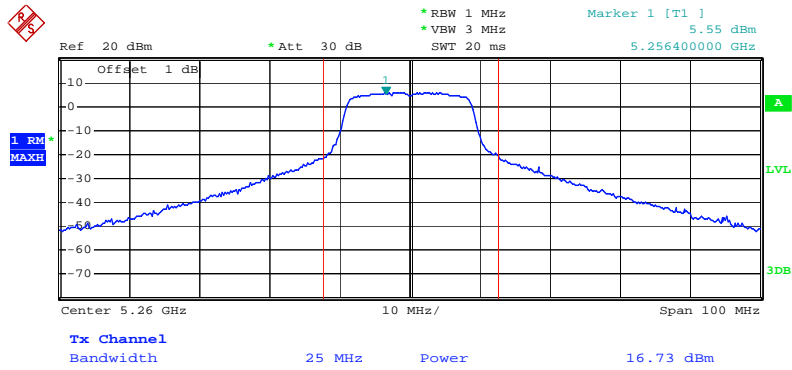

Date: 23.JUN.2009 23:34:51

Conducted Output Power Plot on Configuration Draft n MCS0 20MHz Ant. 1-3 / 5300 MHz

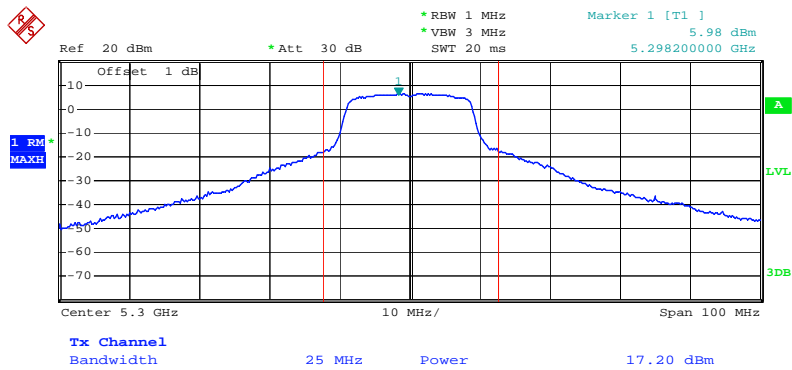

Date: 23.JUN.2009 23:41:07

Conducted Output Power Plot on Configuration Drafft n MCS0 20MHz Ant. 1-3 / 5320 MHz

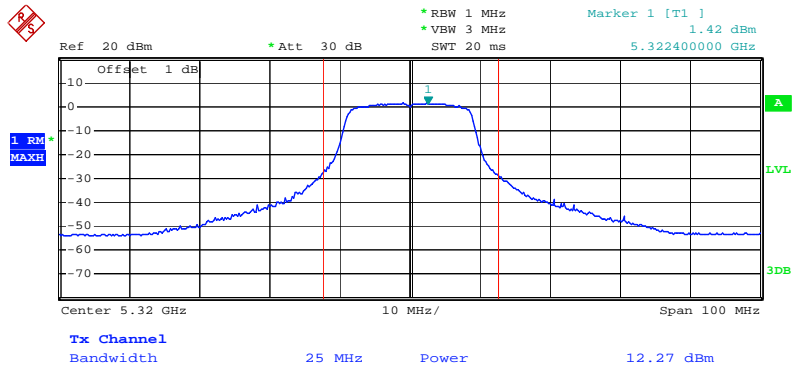

Date: 23.JUN.2009 23:42:53

Conducted Output Power Plot on Configuration Drafft n MCS0 20MHz Ant. 1-3 / 5500 MHz

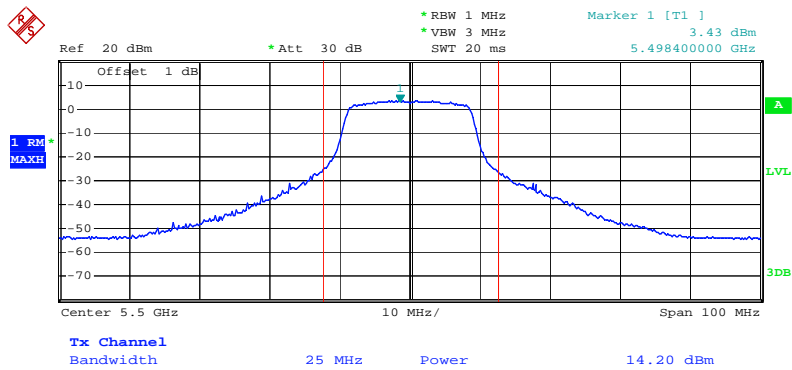

Date: 23.JUN.2009 23:48:51

Conducted Output Power Plot on Configuration Draft n MCS0 20MHz Ant. 1-3 / 5580 MHz

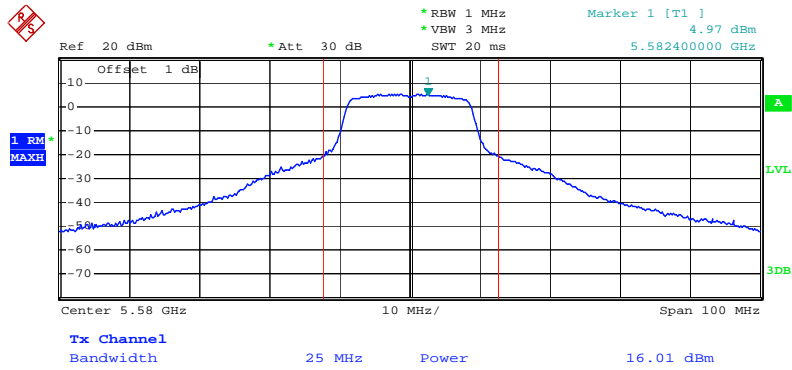

Date: 23.JUN.2009 23:50:25

Conducted Output Power Plot on Configuration Draft n MCS0 20MHz Ant. 1-3 / 5700 MHz

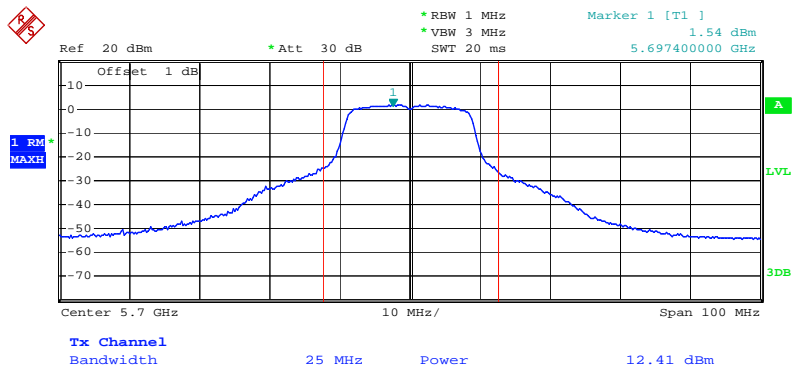

Date: 23.JUN.2009 23:58:51

Conducted Output Power Plot on Configuration Draft n MCS0 40MHz Ant. 1-1 / 5270 MHz

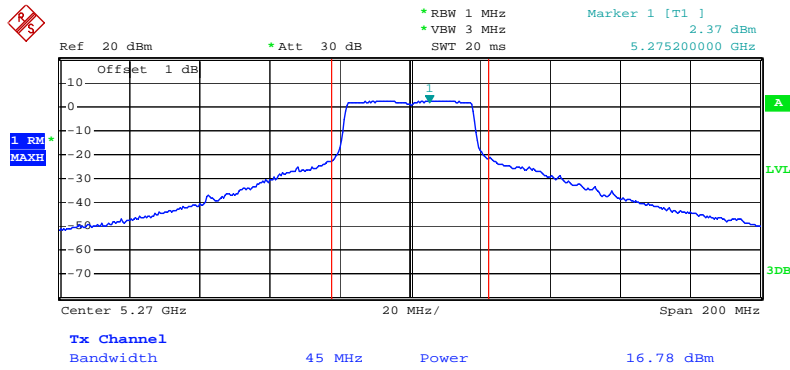

Date: 24.JUN.2009 00:21:10

Conducted Output Power Plot on Configuration Draft n MCS0 40MHz Ant. 1-1 / 5310 MHz

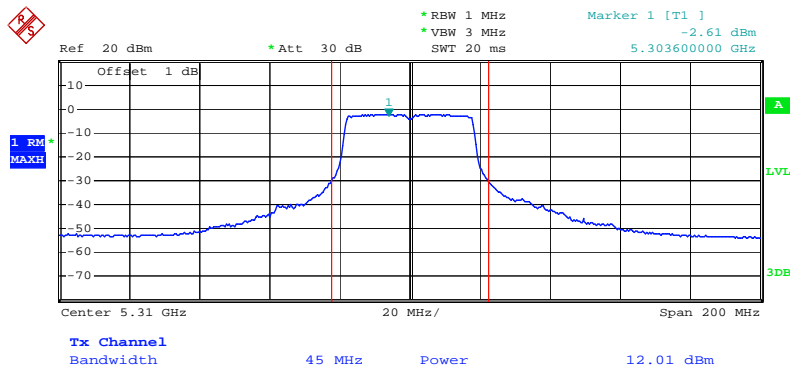

Date: 24.JUN.2009 00:23:15

Conducted Output Power Plot on Configuration Draft n MCS0 40MHz Ant. 1-1 / 5510MHz

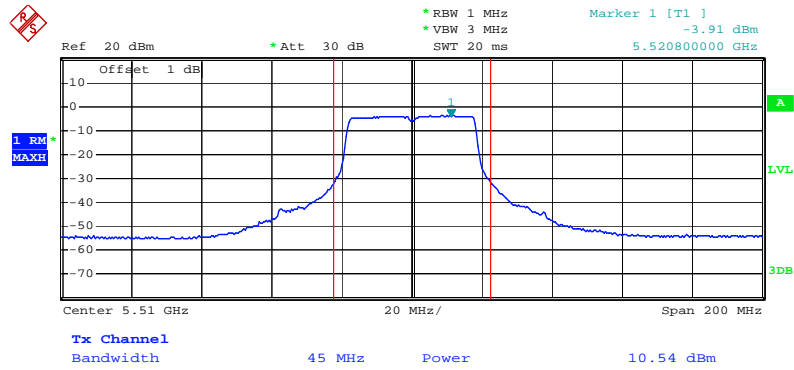

Date: 24.JUN.2009 00:30:55

Conducted Output Power Plot on Configuration Draft n MCS0 40MHz Ant. 1-1 / 5550 MHz

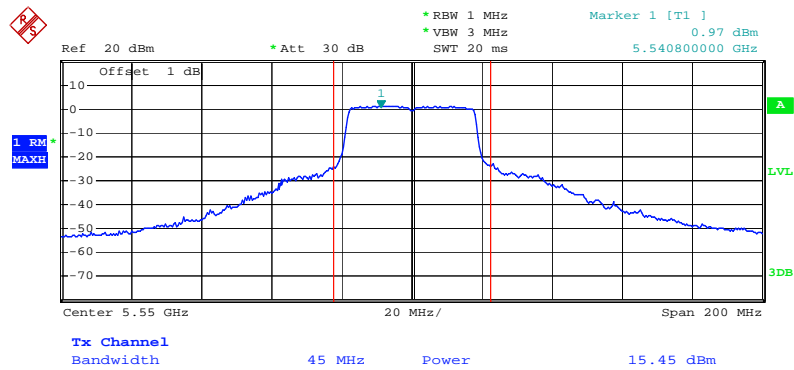

Date: 24.JUN.2009 00:32:10

Conducted Output Power Plot on Configuration Draft n MCS0 40MHz Ant. 1-1 / 5670 MHz

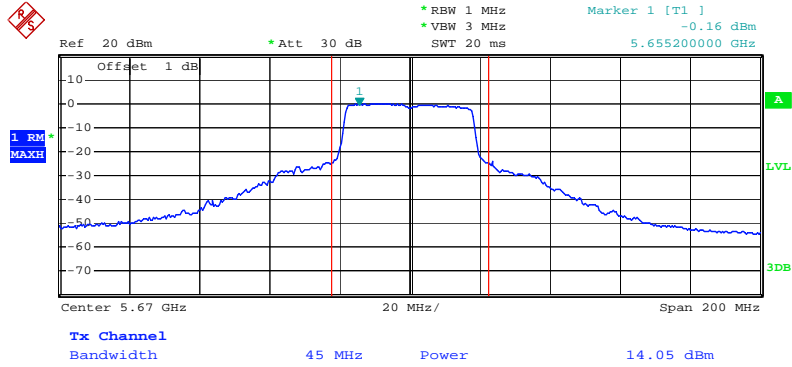

Date: 24.JUN.2009 00:38:26

Conducted Output Power Plot on Configuration Draft n MCS0 40MHz Ant. 1-2 / 5270 MHz

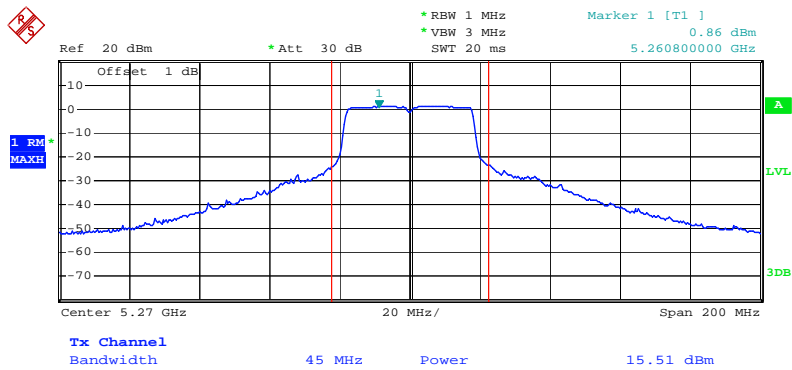

Date: 24.JUN.2009 00:18:38

Conducted Output Power Plot on Configuration Draft n MCS0 40MHz Ant. 1-2 / 5310 MHz

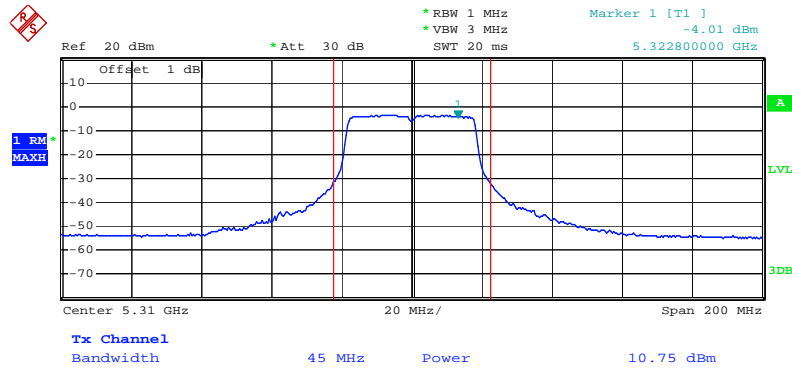

Date: 24.JUN.2009 00:24:19

Conducted Output Power Plot on Configuration Draft n MCS0 40MHz Ant. 1-2 / 5510MHz

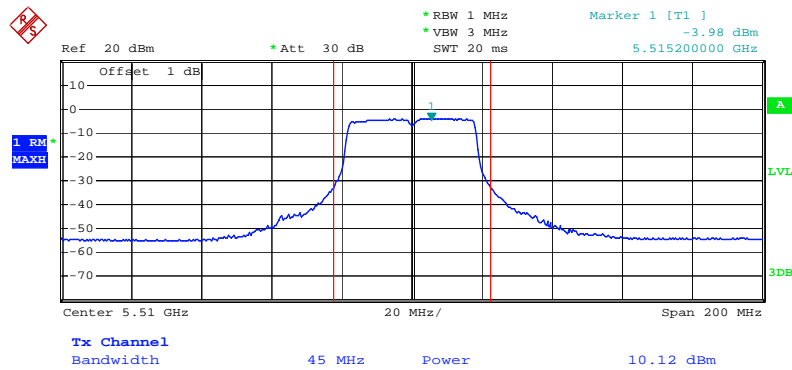

Date: 24.JUN.2009 00:29:12

Conducted Output Power Plot on Configuration Draft n MCS0 40MHz Ant. 1-2 / 5550 MHz

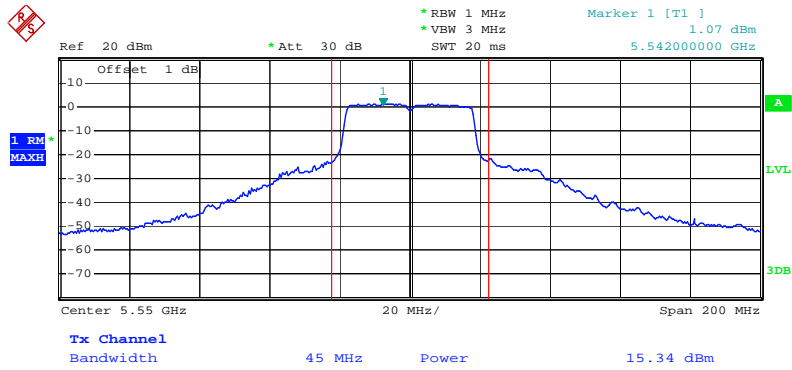

Date: 24.JUN.2009 00:33:17

Conducted Output Power Plot on Configuration Draft n MCS0 40MHz Ant. 1-2 / 5670 MHz

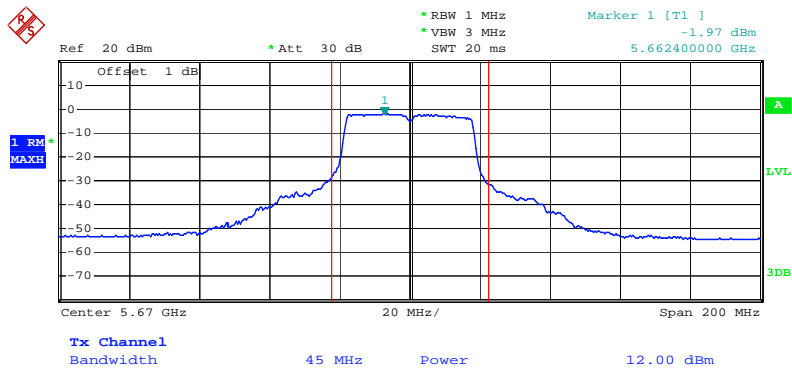

Date: 24.JUN.2009 00:37:41

Conducted Output Power Plot on Configuration Draft n MCS0 40MHz Ant. 1-3 / 5270 MHz

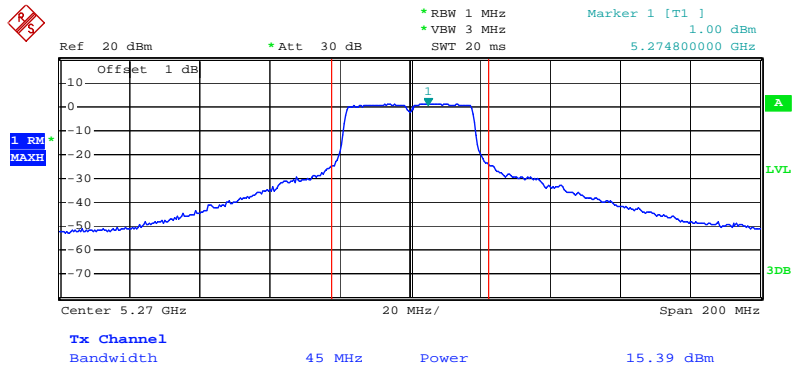

Date: 24.JUN.2009 00:20:00

Conducted Output Power Plot on Configuration Draft n MCS0 40MHz Ant. 1-3 / 5310 MHz

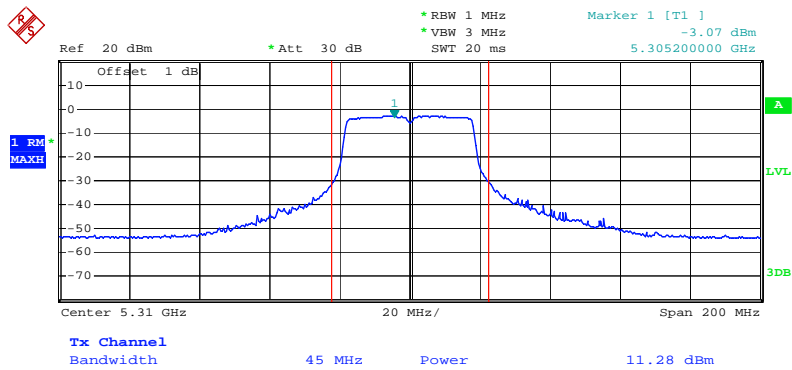

Date: 24.JUN.2009 00:25:24

Conducted Output Power Plot on Configuration Draft n MCS0 40MHz Ant. 1-3 / 5510MHz

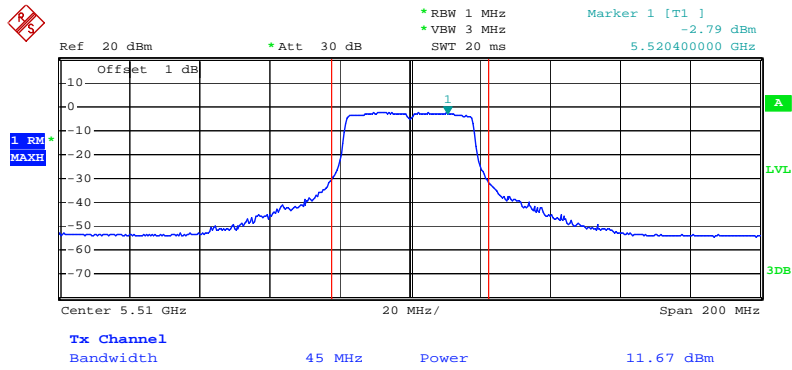

Date: 24.JUN.2009 00:27:49

Conducted Output Power Plot on Configuration Draft n MCS0 40MHz Ant. 1-3 / 5550 MHz

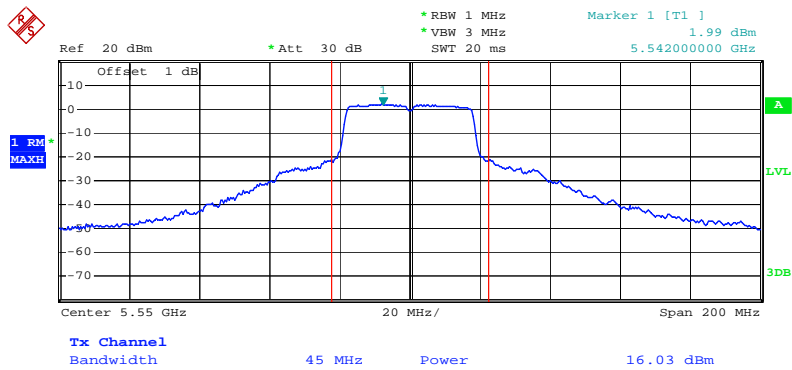

Date: 24.JUN.2009 00:34:50

Conducted Output Power Plot on Configuration Draft n MCS0 40MHz Ant. 1-3 / 5670 MHz

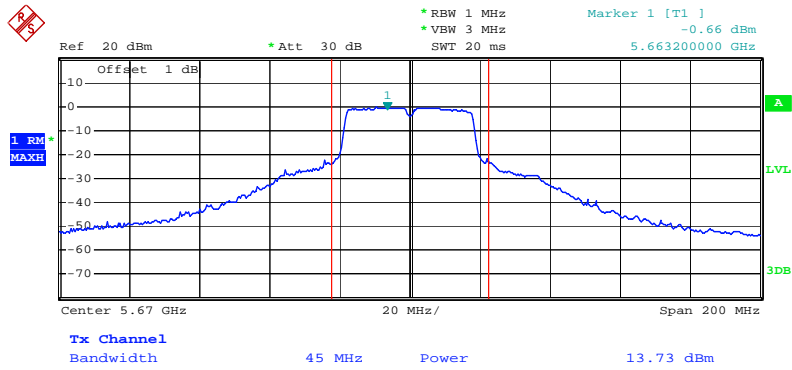

Date: 24.JUN.2009 00:36:09

Conducted Output Power Plot on Configuration IEEE 802.11a Ant. 1-1 / 5260 MHz

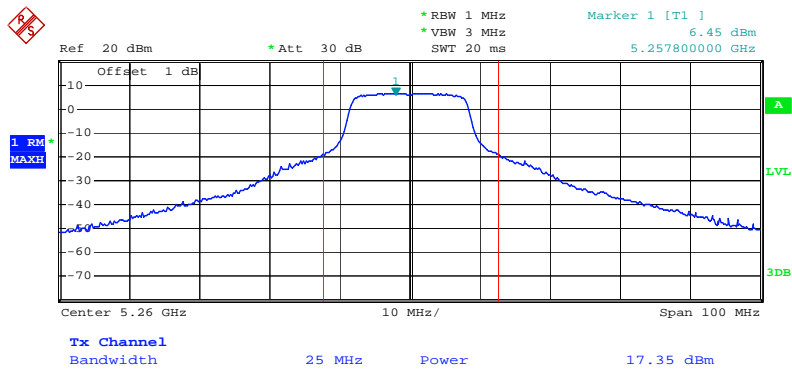

Date: 23.JUN.2009 22:41:23

Conducted Output Power Plot on Configuration IEEE 802.11a Ant. 1-1 / 5300 MHz

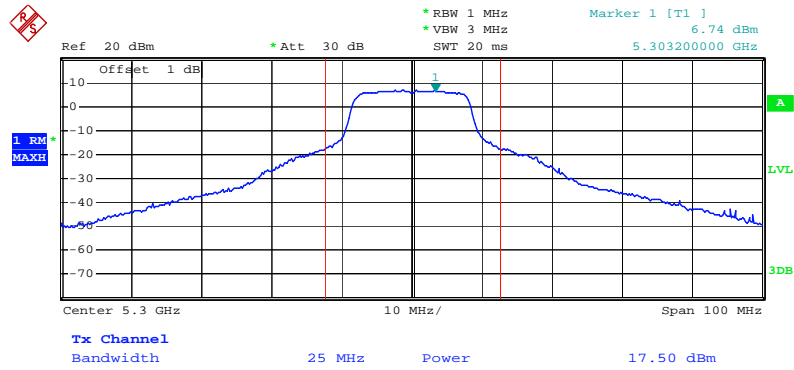

Date: 23.JUN.2009 22:43:06

Conducted Output Power Plot on Configuration IEEE 802.11a Ant. 1-1 / 5320 MHz

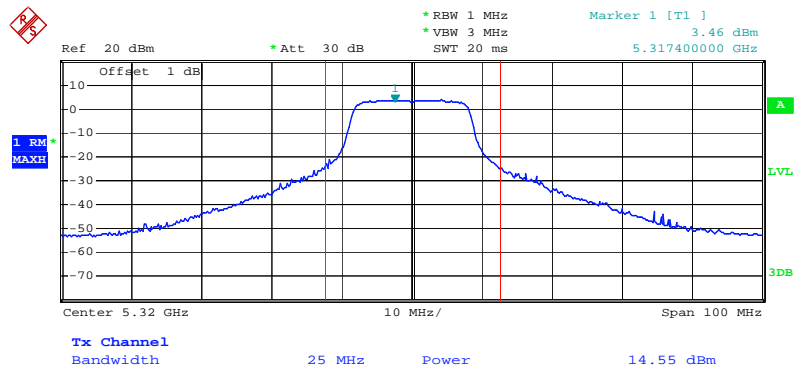

Date: 23.JUN.2009 22:50:27

Conducted Output Power Plot on Configuration IEEE 802.11a Ant. 1-1 / 5500 MHz

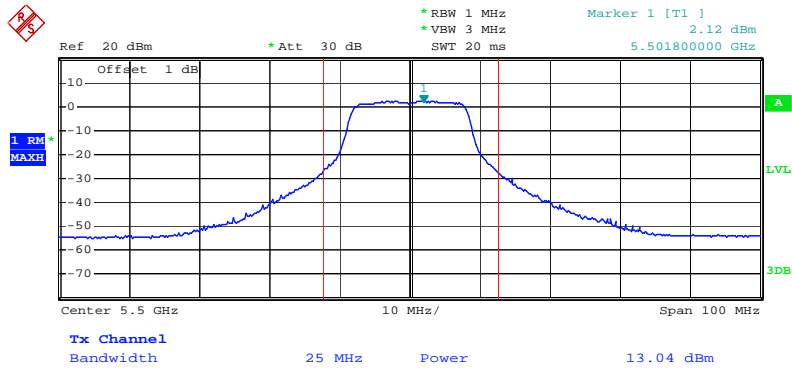

Date: 23.JUN.2009 22:52:58

Conducted Output Power Plot on Configuration IEEE 802.11a Ant. 1-1 / 5580 MHz

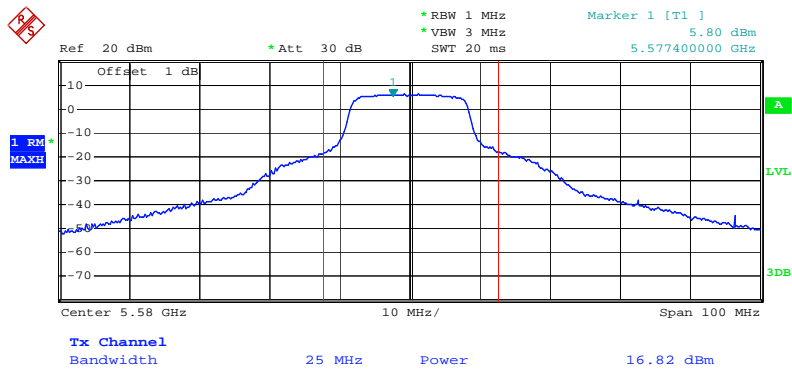

Date: 23.JUN.2009 22:58:56

Conducted Output Power Plot on Configuration IEEE 802.11a Ant. 1-2 / 5300 MHz

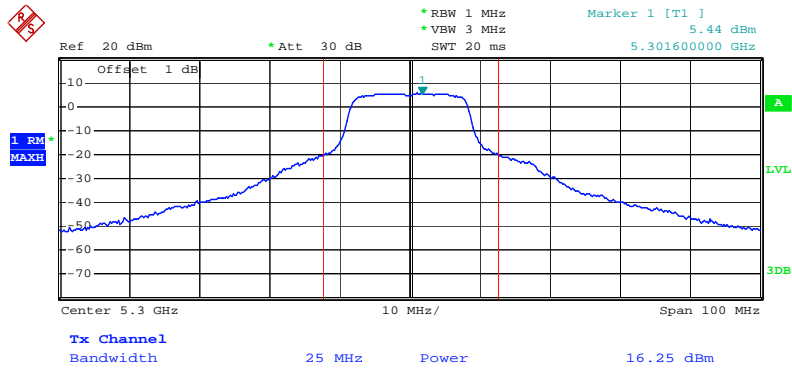

Date: 23.JUN.2009 22:44:08

Conducted Output Power Plot on Configuration IEEE 802.11a Ant. 1-2 / 5320 MHz

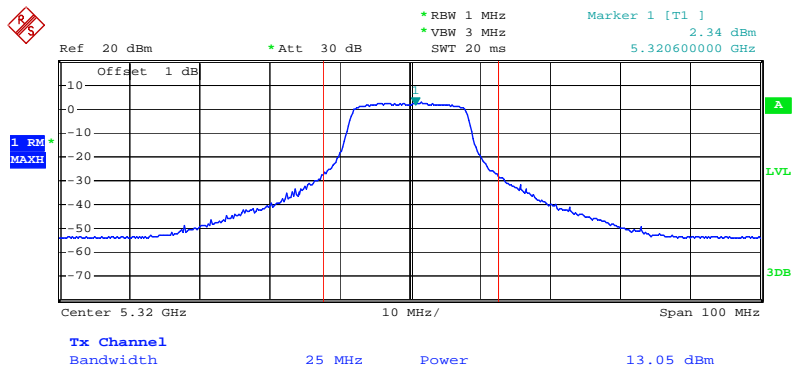

Date: 23.JUN.2009 22:49:19

Conducted Output Power Plot on Configuration IEEE 802.11a Ant. 1-2 / 5500 MHz

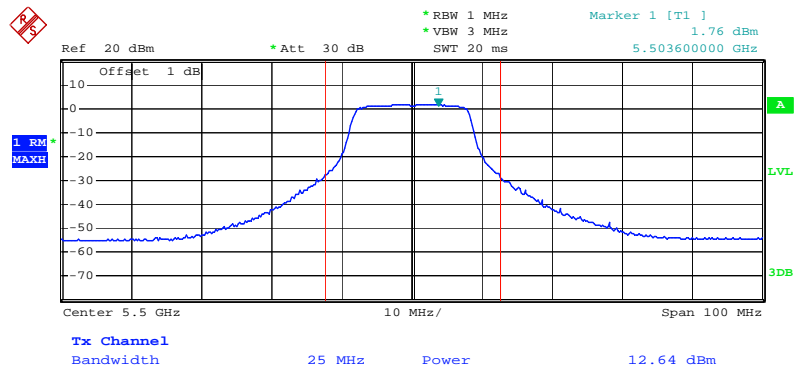

Date: 23.JUN.2009 22:54:38

Conducted Output Power Plot on Configuration IEEE 802.11a Ant. 1-2 / 5580 MHz

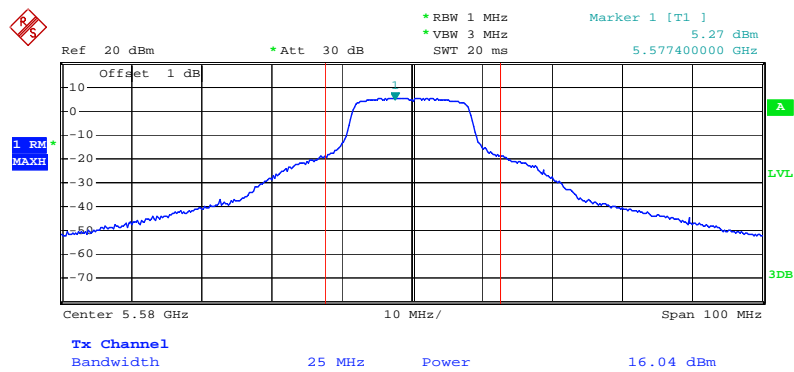

Date: 23.JUN.2009 23:00:02

Conducted Output Power Plot on Configuration IEEE 802.11a Ant. 1-2 / 5700 MHz

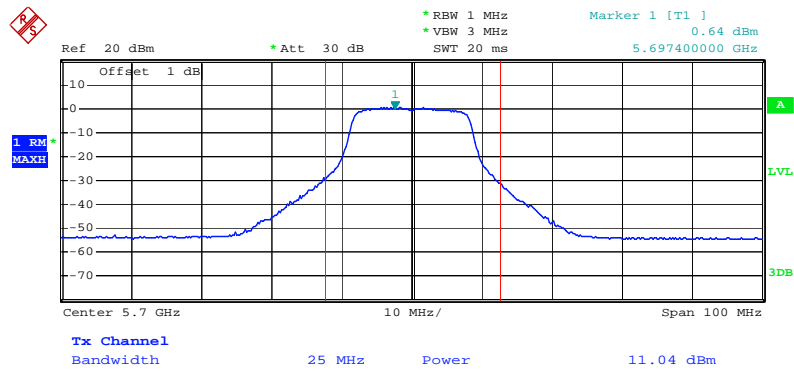

Date: 23.JUN.2009 23:04:28

Conducted Output Power Plot on Configuration IEEE 802.11a Ant. 1-3 / 5260 MHz

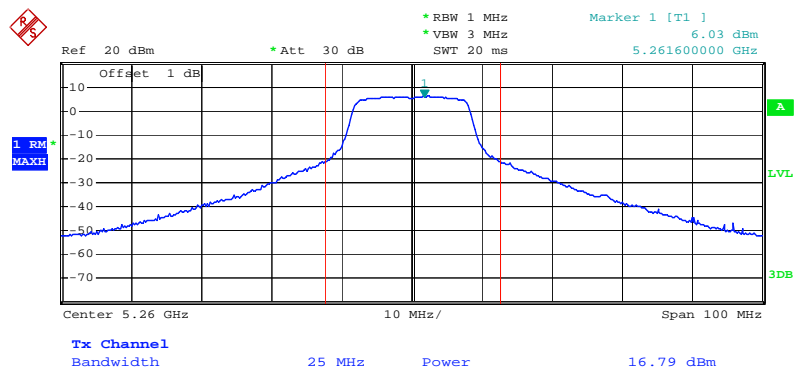

Date: 23.JUN.2009 22:37:37

Conducted Output Power Plot on Configuration IEEE 802.11a Ant. 1-3 / 5300 MHz

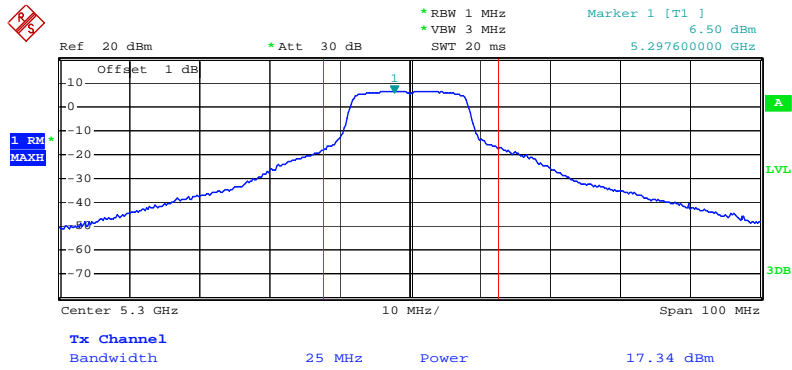

Date: 23.JUN.2009 22:45:37

Conducted Output Power Plot on Configuration IEEE 802.11a Ant. 1-3 / 5320 MHz

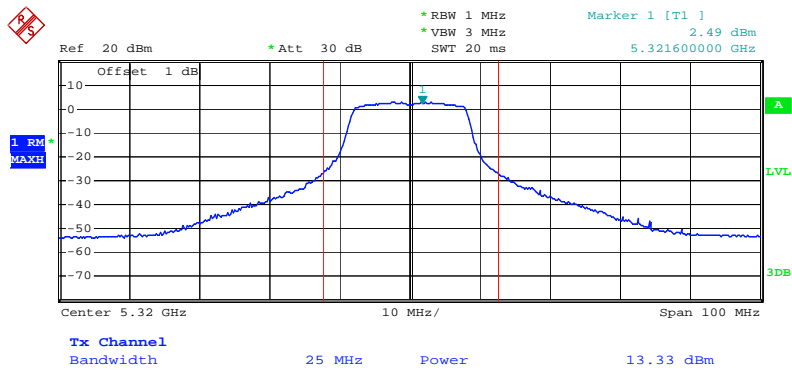

Date: 23.JUN.2009 22:47:48

Conducted Output Power Plot on Configuration IEEE 802.11a Ant. 1-3 / 5500 MHz

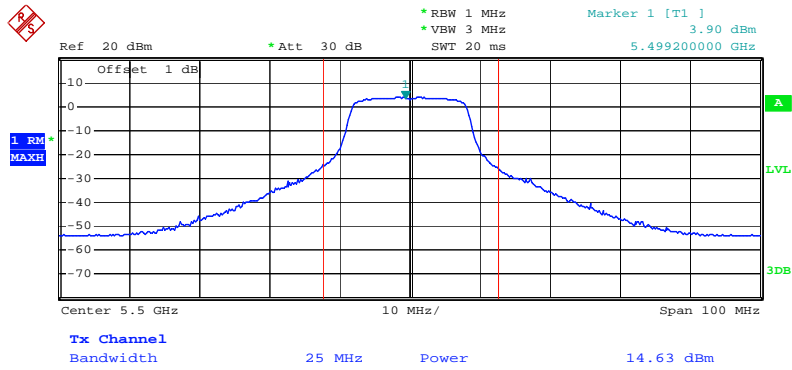

Date: 23.JUN.2009 22:55:58

Conducted Output Power Plot on Configuration IEEE 802.11a Ant. 1-3 / 5580 MHz

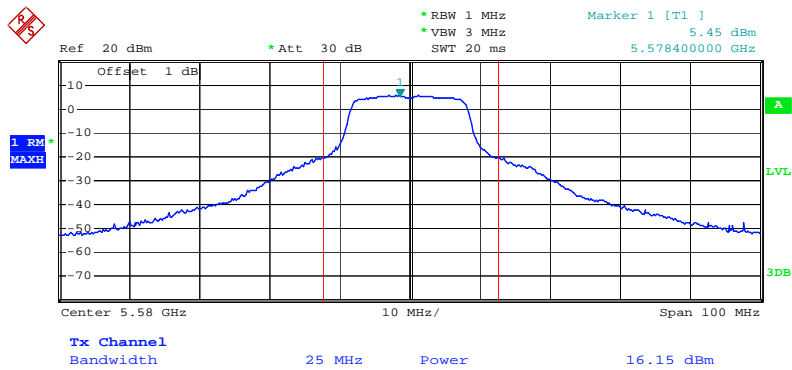

Date: 23.JUN.2009 23:01:21

Conducted Output Power Plot on Configuration IEEE 802.11a Ant. 1-3 / 5700 MHz

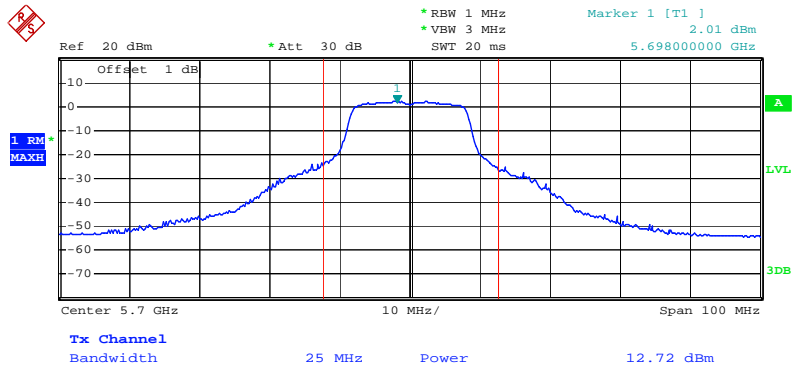

Date: 23.JUN.2009 23:03:34

<For Antenna 2>:

Conducted Output Power Plot on Configuration Draft n MCS0 20MHz Ant. 2-1 / 5260 MHz

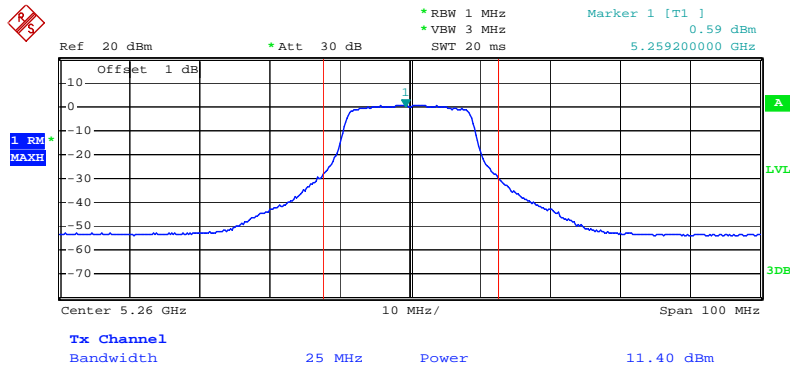

Date: 24.JUN.2009 22:13:00

Conducted Output Power Plot on Configuration Draft n MCS0 20MHz Ant. 2-1 / 5300 MHz

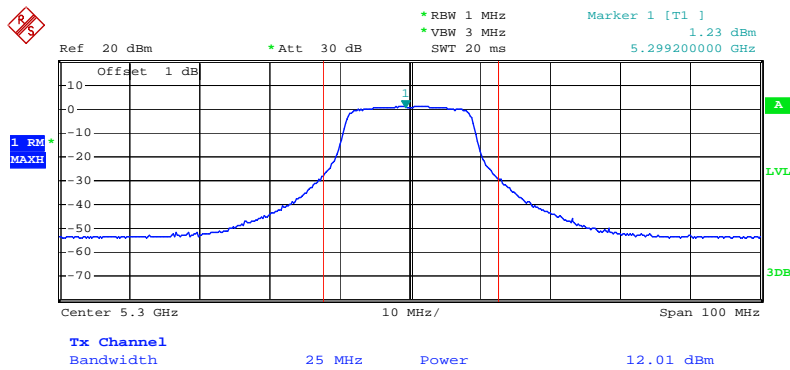

Date: 24.JUN.2009 22:23:24

Conducted Output Power Plot on Configuration Draft n MCS0 20MHz Ant. 2-1 / 5320 MHz

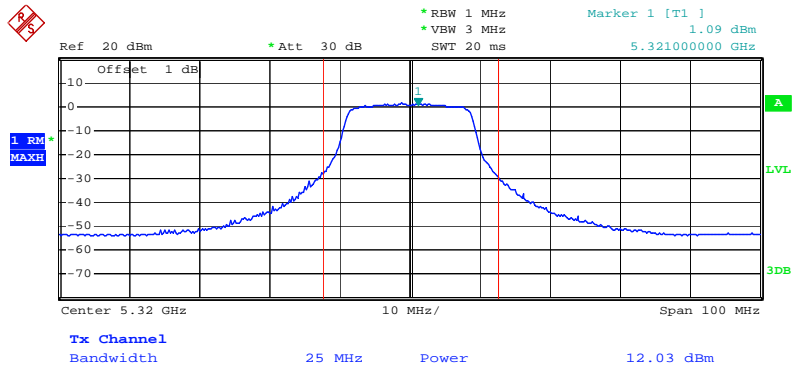

Date: 24.JUN.2009 22:31:24

Conducted Output Power Plot on Configuration Draft n MCS0 20MHz Ant. 2-1 / 5500 MHz

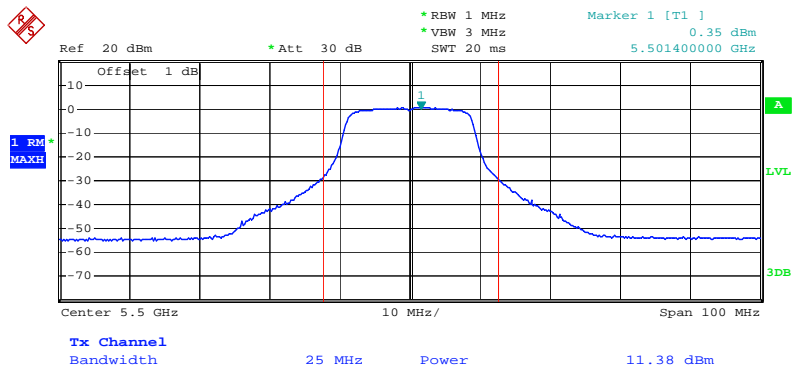

Date: 24.JUN.2009 22:38:29

Conducted Output Power Plot on Configuration Draft n MCS0 20MHz Ant. 2-1 / 5580 MHz

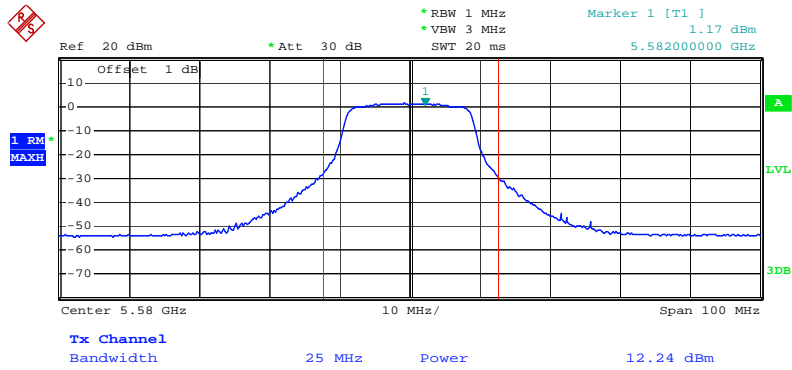

Date: 24.JUN.2009 22:40:15

Conducted Output Power Plot on Configuration Draft n MCS0 20MHz Ant. 2-1 / 5700 MHz

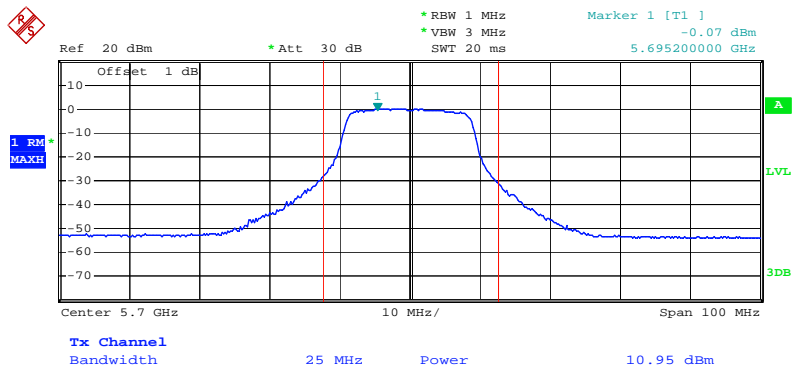

Date: 24.JUN.2009 22:46:50

Conducted Output Power Plot on Configuration Draft n MCS0 20MHz Ant. 2-2 / 5260 MHz

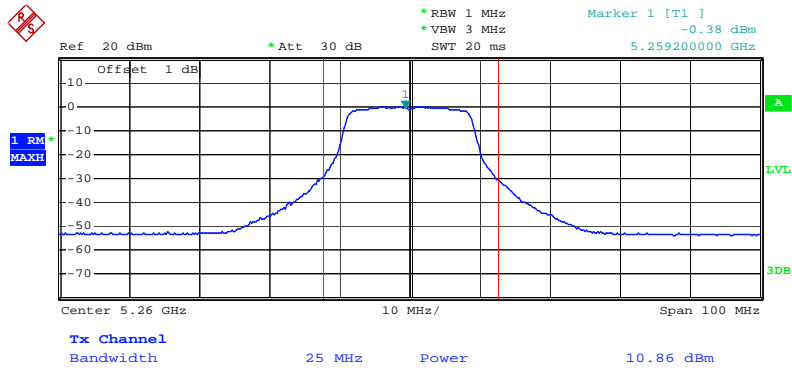

Date: 24.JUN.2009 22:15:35

Conducted Output Power Plot on Configuration Draft n MCS0 20MHz Ant. 2-2 / 5300 MHz

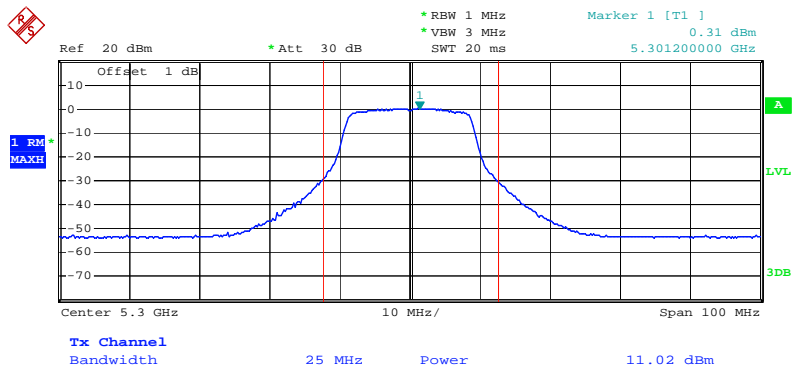

Date: 24.JUN.2009 22:25:06

Conducted Output Power Plot on Configuration Draft n MCS0 20MHz Ant. 2-2 / 5320 MHz

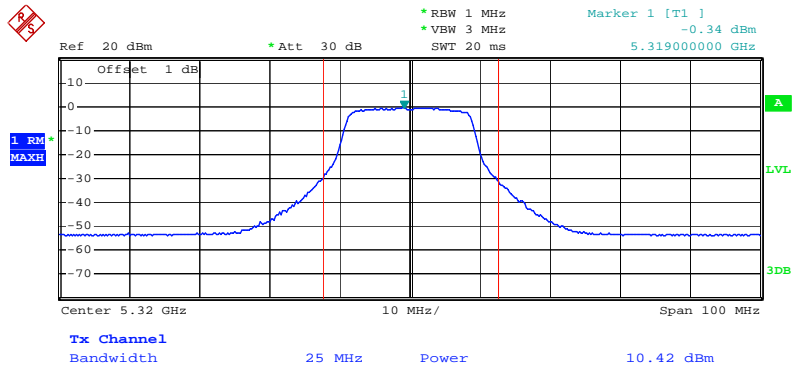

Date: 24.JUN.2009 22:33:00

Conducted Output Power Plot on Configuration Draft n MCS0 20MHz Ant. 2-2 / 5500 MHz

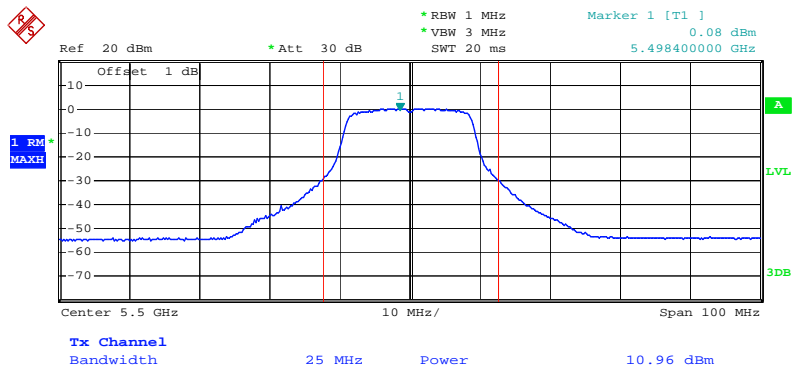

Date: 24.JUN.2009 22:37:22

Conducted Output Power Plot on Configuration Draft n MCS0 20MHz Ant. 2-2 / 5580 MHz

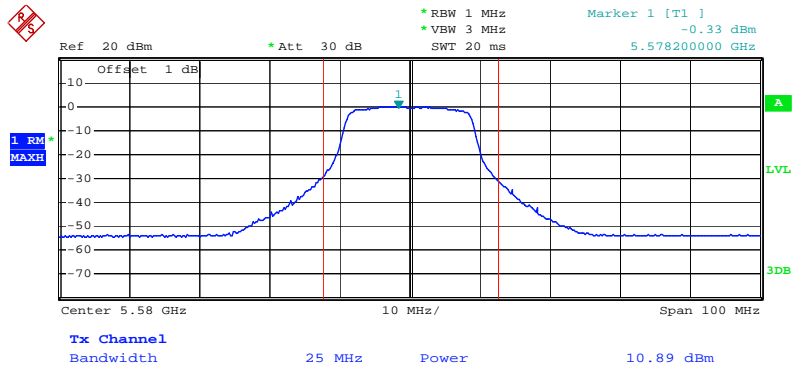

Date: 24.JUN.2009 22:41:24

Conducted Output Power Plot on Configuration Draft n MCS0 20MHz Ant. 2-2 / 5700 MHz

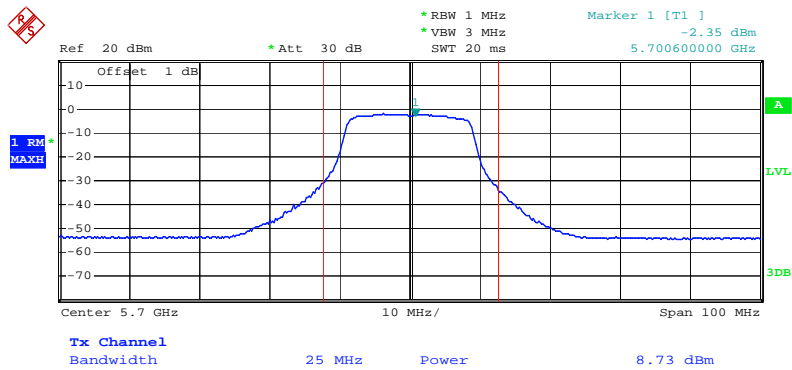

Date: 24.JUN.2009 22:45:29

Conducted Output Power Plot on Configuration Draft n MCS0 20MHz Ant. 2-3 / 5260 MHz

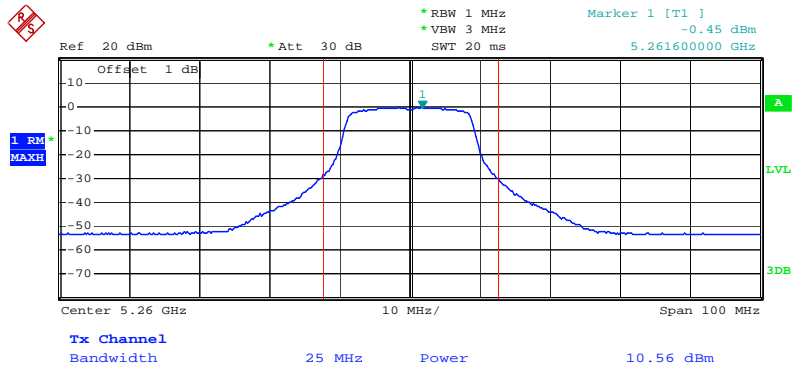

Date: 24.JUN.2009 22:18:30

Conducted Output Power Plot on Configuration Draft n MCS0 20MHz Ant. 2-3 / 5300 MHz

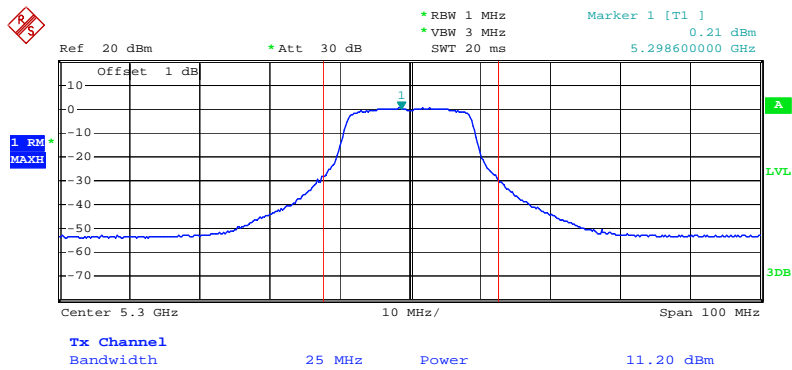

Date: 24.JUN.2009 22:26:50

Conducted Output Power Plot on Configuration Draft n MCS0 20MHz Ant. 2-3 / 5320 MHz

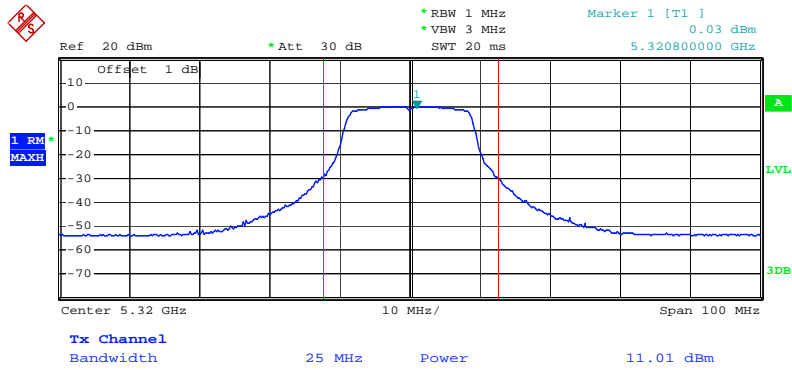

Date: 24.JUN.2009 22:28:30

Conducted Output Power Plot on Configuration Draft n MCS0 20MHz Ant. 2-3 / 5500 MHz

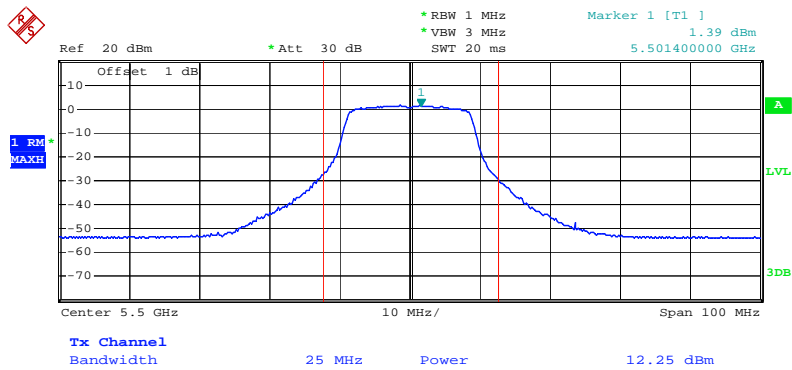

Date: 24.JUN.2009 22:35:44

Conducted Output Power Plot on Configuration Draft n MCS0 20MHz Ant. 2-3 / 5580 MHz

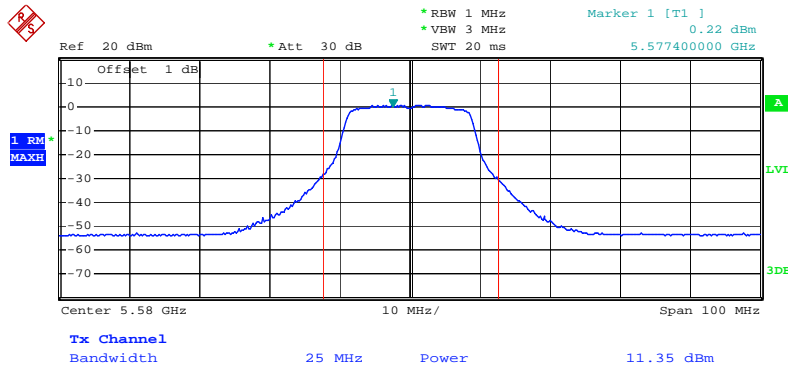

Date: 24.JUN.2009 22:42:39

Conducted Output Power Plot on Configuration Draft n MCS0 20MHz Ant. 2-3 / 5700 MHz

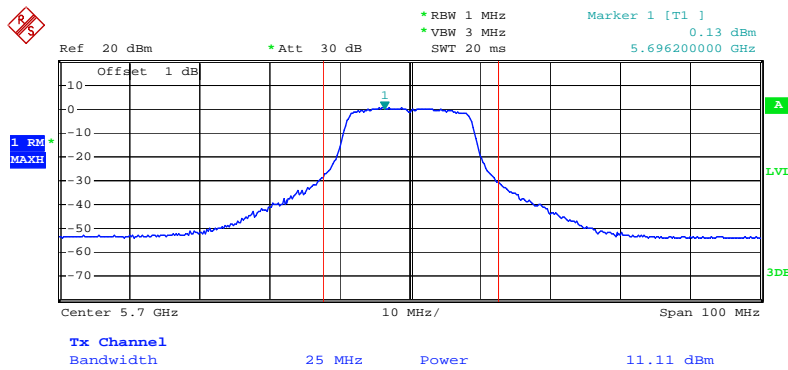

Date: 24.JUN.2009 22:44:32

Conducted Output Power Plot on Configuration Draft n MCS0 40MHz Ant. 2-1 / 5510MHz

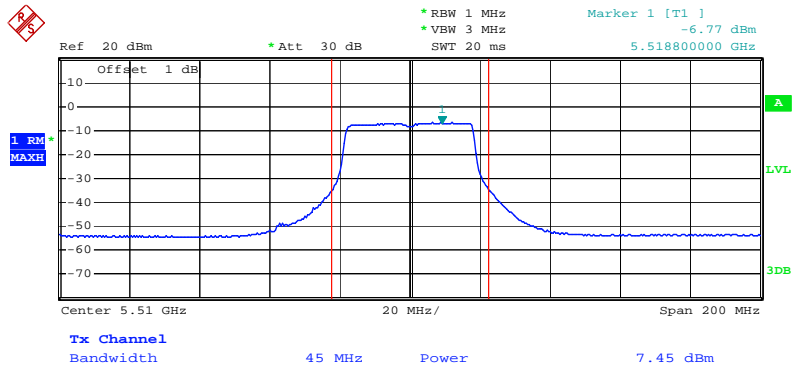

Date: 24.JUN.2009 23:31:07

Conducted Output Power Plot on Configuration Draft n MCS0 40MHz Ant. 2-2 / 5550 MHz

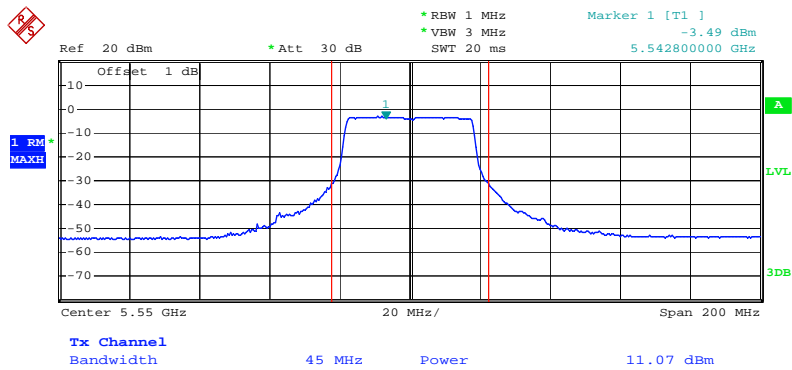

Date: 24.JUN.2009 23:40:35

Conducted Output Power Plot on Configuration Draft n MCS0 40MHz Ant. 2-2 / 5670 MHz

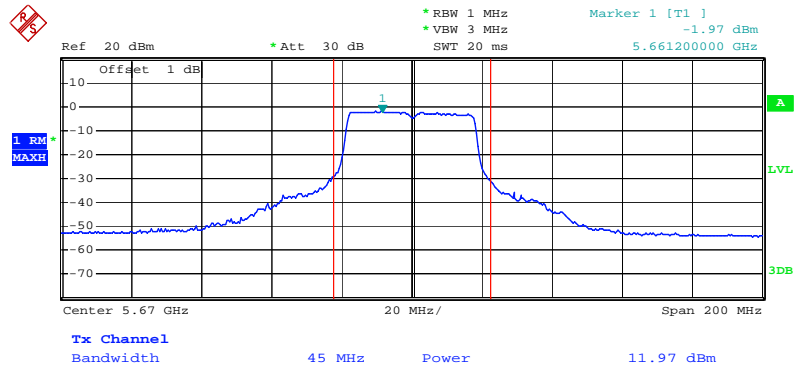

Date: 24.JUN.2009 23:49:02

Conducted Output Power Plot on Configuration Draft n MCS0 40MHz Ant. 2-2 / 5270 MHz

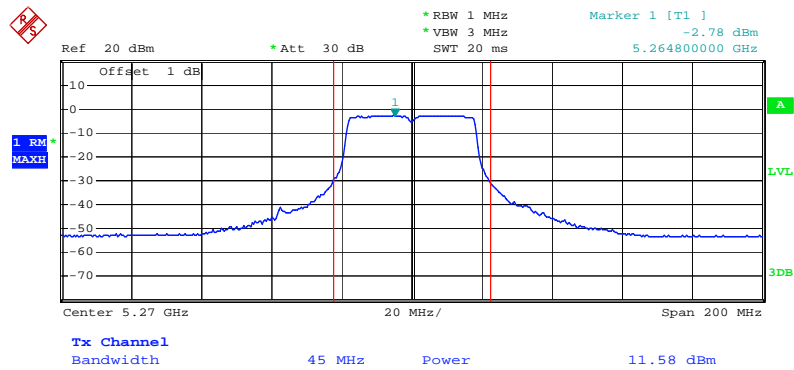

Date: 24.JUN.2009 23:20:05

Conducted Output Power Plot on Configuration Draft n MCS0 40MHz Ant. 2-2 / 5310 MHz

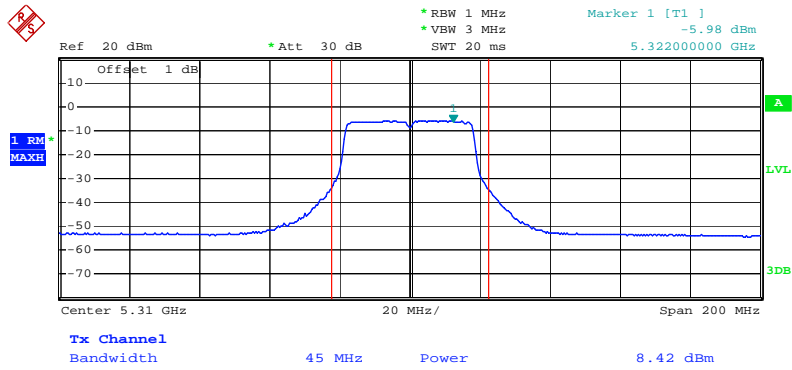

Date: 24.JUN.2009 23:26:30

Conducted Output Power Plot on Configuration Draft n MCS0 40MHz Ant. 2-2 / 5510MHz

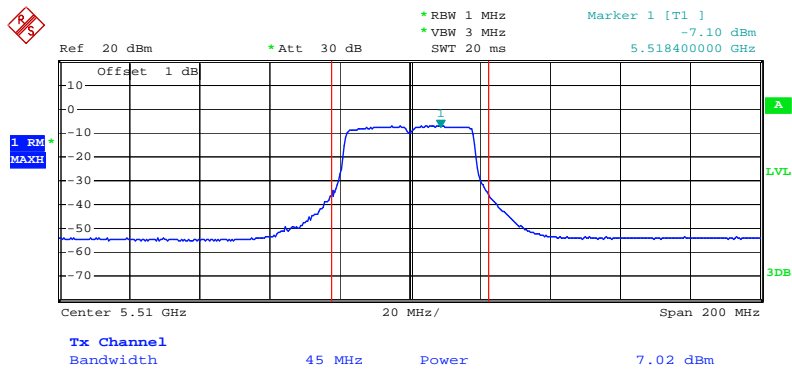

Date: 24.JUN.2009 23:32:25

Conducted Output Power Plot on Configuration Draft n MCS0 40MHz Ant. 2-2 / 5550 MHz

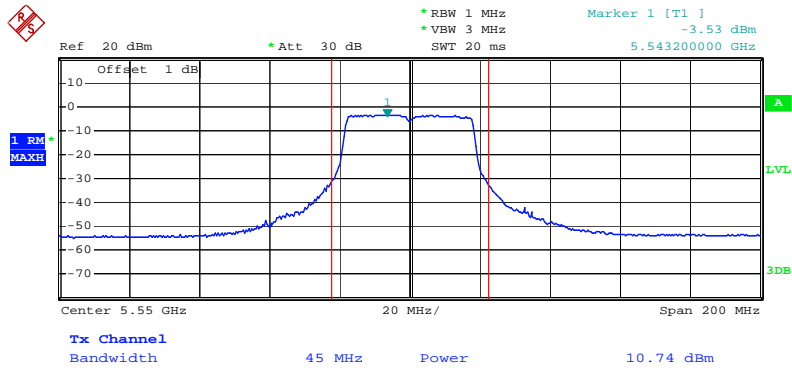

Date: 24.JUN.2009 23:42:10

Conducted Output Power Plot on Configuration Draft n MCS0 40MHz Ant. 2-2 / 5670 MHz

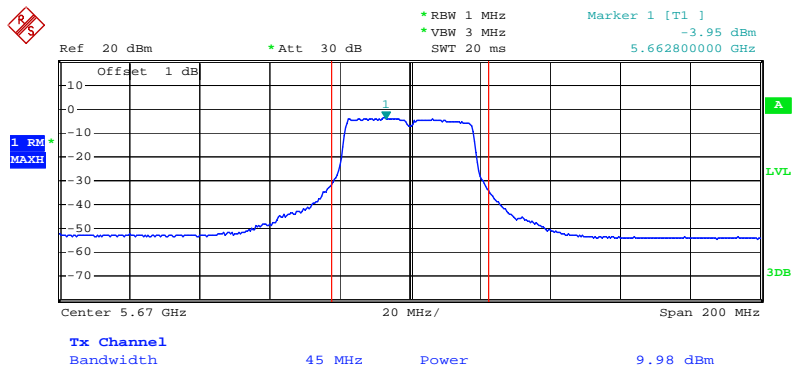

Date: 24.JUN.2009 23:50:34

Conducted Output Power Plot on Configuration Draft n MCS0 40MHz Ant. 2-3 / 5270 MHz

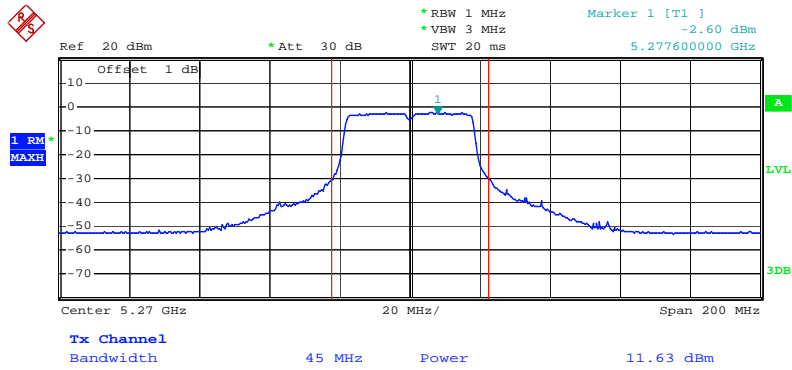

Date: 24.JUN.2009 23:17:33

Conducted Output Power Plot on Configuration Draft n MCS0 40MHz Ant. 2-3 / 5310 MHz

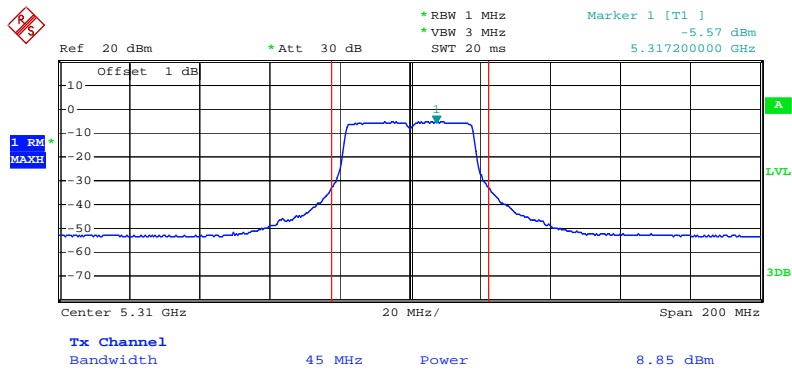

Date: 24.JUN.2009 23:27:44

Conducted Output Power Plot on Configuration Draft n MCS0 40MHz Ant. 2-3 / 5510MHz

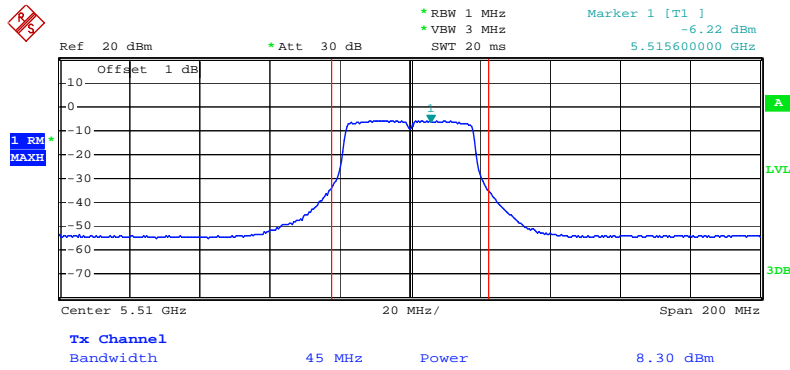

Date: 24.JUN.2009 23:33:34

Conducted Output Power Plot on Configuration Draft n MCS0 40MHz Ant. 2-3 / 5550 MHz

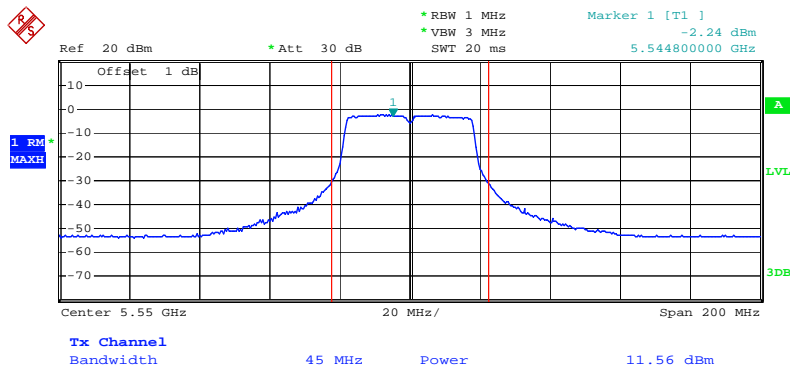

Date: 24.JUN.2009 23:44:39

Conducted Output Power Plot on Configuration Draft n MCS0 40MHz Ant. 2-3 / 5670 MHz

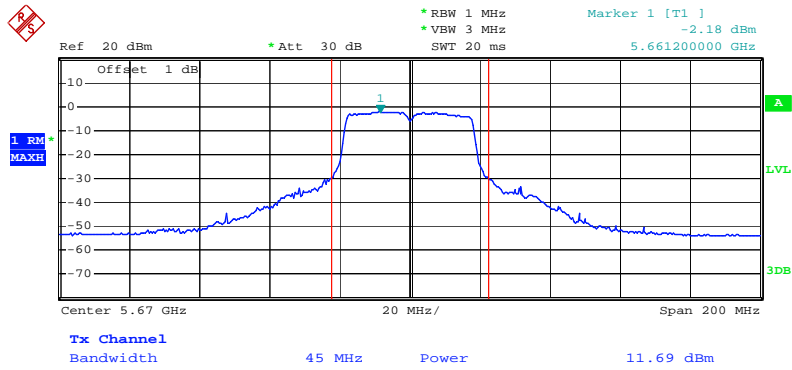

Date: 24.JUN.2009 23:52:30

Conducted Output Power Plot on Configuration IEEE 802.11a Ant. 2-1 / 5260 MHz

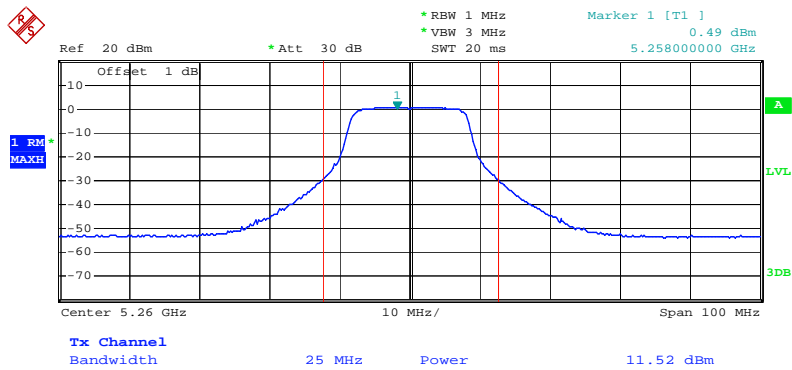

Date: 24.JUN.2009 21:03:38

Conducted Output Power Plot on Configuration IEEE 802.11a Ant. 2-1 / 5300 MHz

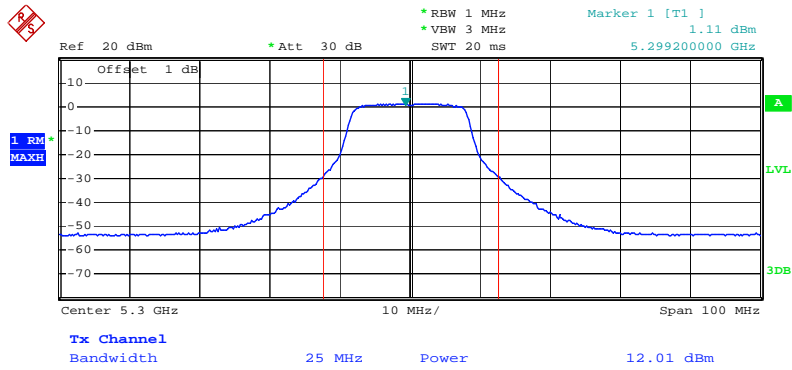

Date: 24.JUN.2009 21:12:19

Conducted Output Power Plot on Configuration IEEE 802.11a Ant. 2-1 / 5320 MHz

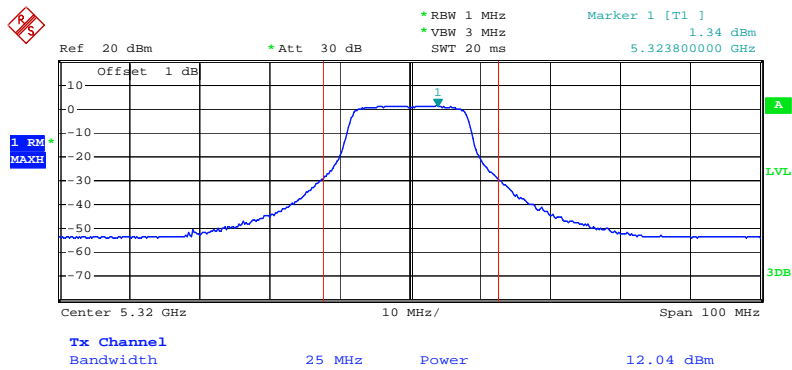

Date: 24.JUN.2009 21:13:56

Conducted Output Power Plot on Configuration IEEE 802.11a Ant. 2-1 / 5700 MHz

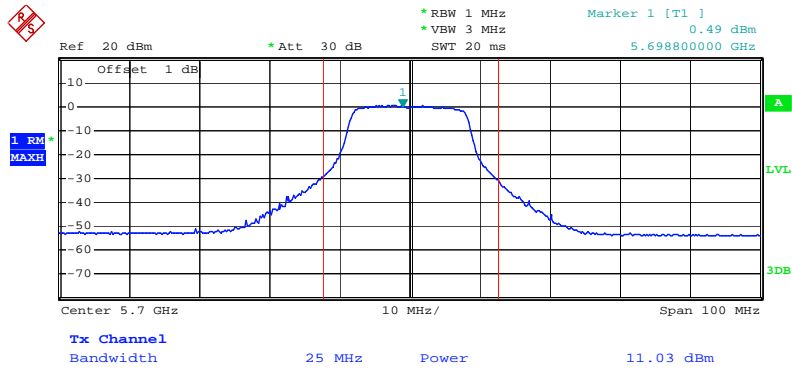

Date: 24.JUN.2009 21:34:40

Conducted Output Power Plot on Configuration IEEE 802.11a Ant. 2-2 / 5260 MHz

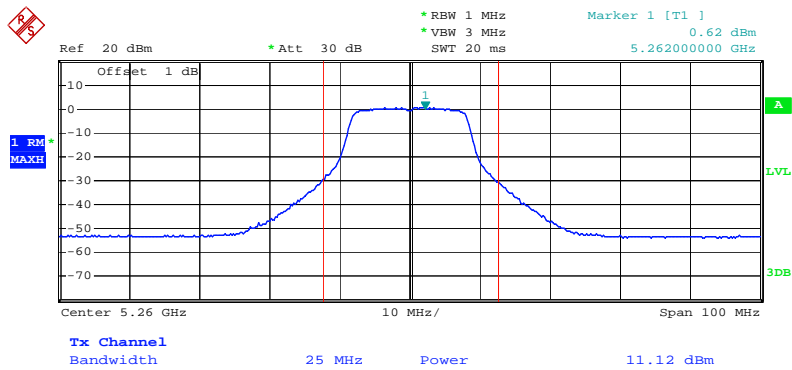

Date: 24.JUN.2009 20:55:48

Conducted Output Power Plot on Configuration IEEE 802.11a Ant. 2-2 / 5300 MHz

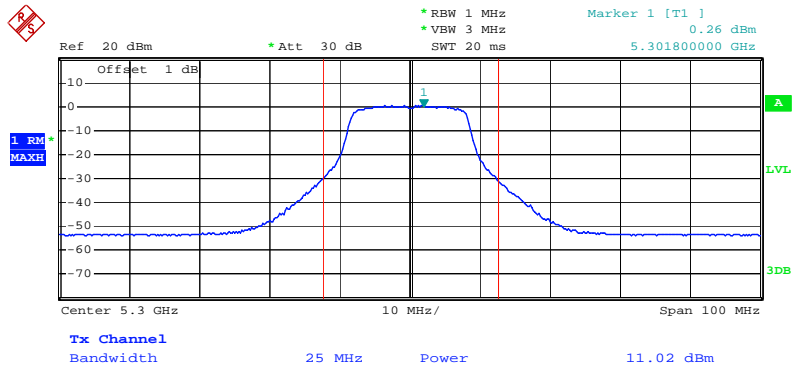

Date: 24.JUN.2009 21:10:49

Conducted Output Power Plot on Configuration IEEE 802.11a Ant. 2-2 / 5320 MHz

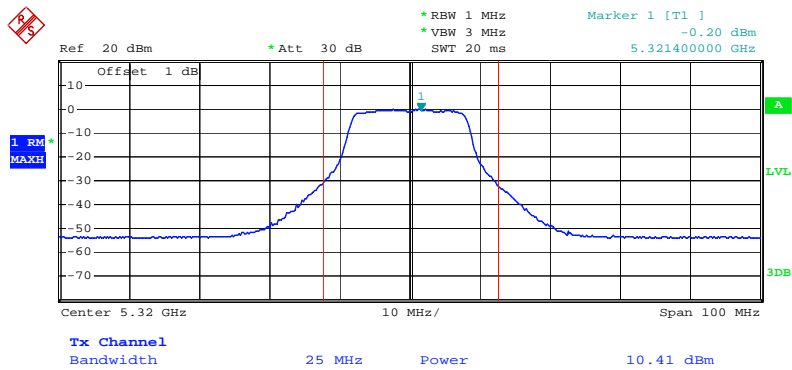

Date: 24.JUN.2009 21:14:42

Conducted Output Power Plot on Configuration IEEE 802.11a Ant. 2-2 / 5500 MHz

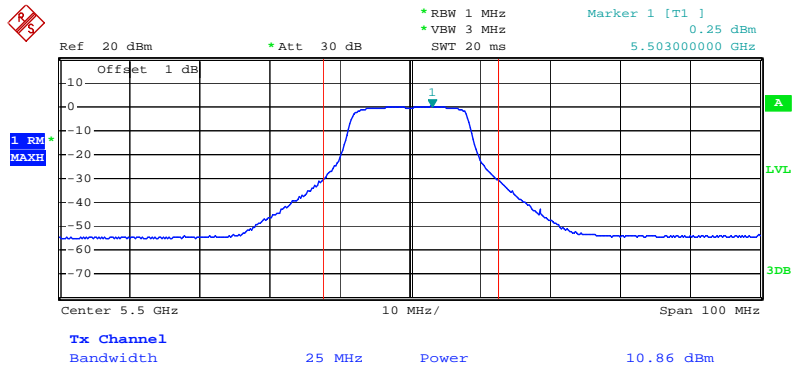

Date: 24.JUN.2009 21:23:16

Conducted Output Power Plot on Configuration IEEE 802.11a Ant. 2-2 / 5580 MHz

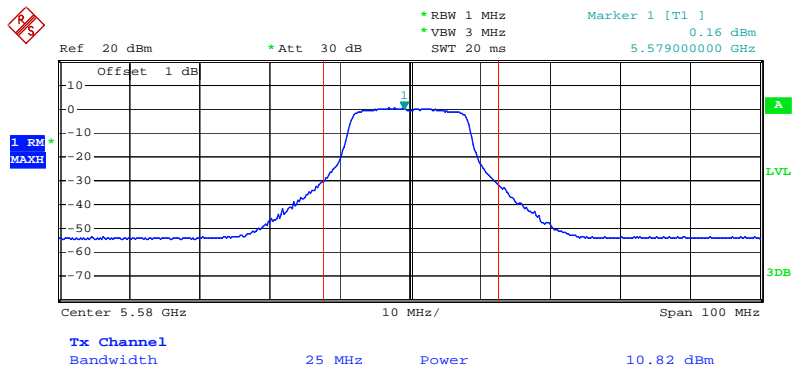

Date: 24.JUN.2009 21:30:29

Conducted Output Power Plot on Configuration IEEE 802.11a Ant. 2-2 / 5700 MHz

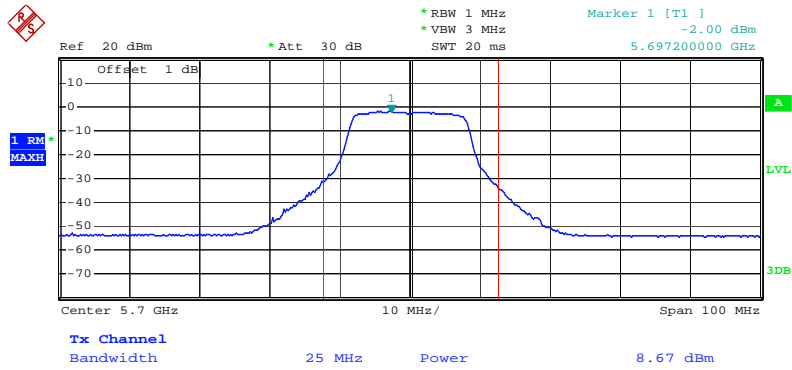

Date: 24.JUN.2009 21:36:00

Conducted Output Power Plot on Configuration IEEE 802.11a Ant. 2-3 / 5260 MHz

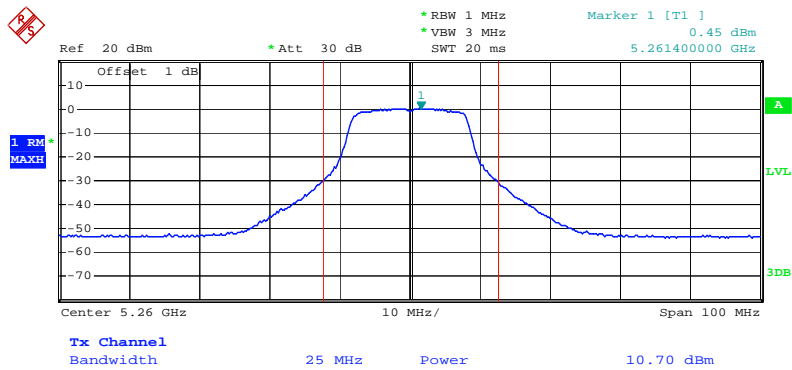

Date: 24.JUN.2009 21:06:33

Conducted Output Power Plot on Configuration IEEE 802.11a Ant. 2-3 / 5300 MHz

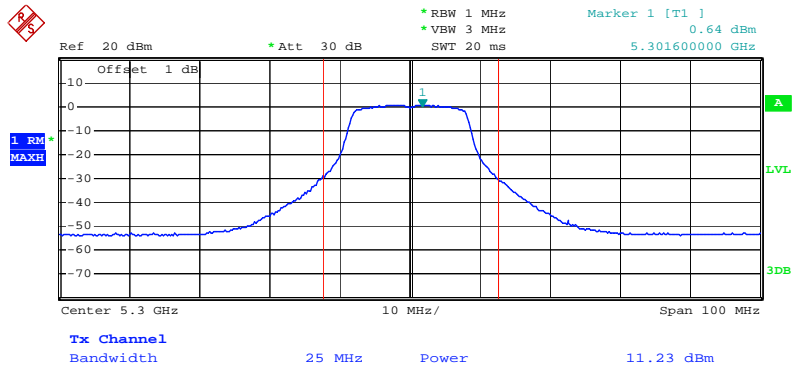

Date: 24.JUN.2009 21:08:53

Conducted Output Power Plot on Configuration IEEE 802.11a Ant. 2-3 / 5320 MHz

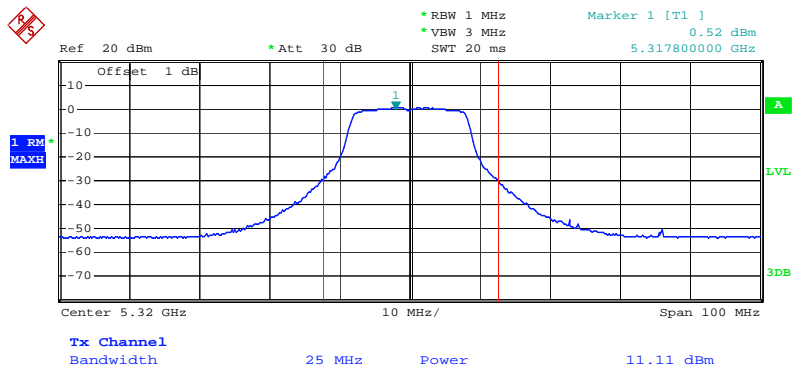

Date: 24.JUN.2009 21:16:57

Conducted Output Power Plot on Configuration IEEE 802.11a Ant. 2-3 / 5500 MHz

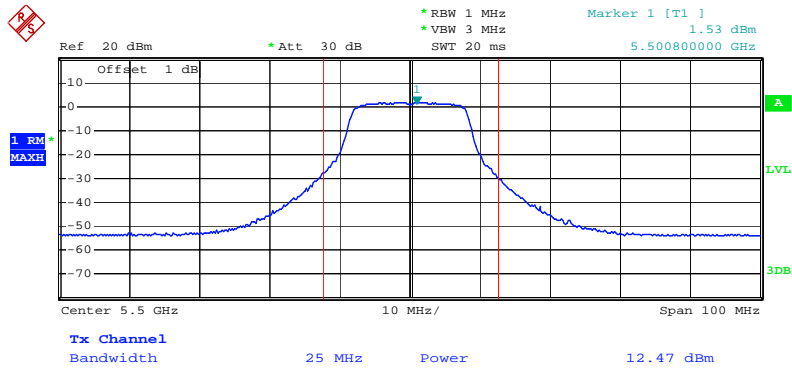

Date: 24.JUN.2009 21:24:42

Conducted Output Power Plot on Configuration IEEE 802.11a Ant. 2-3 / 5580 MHz

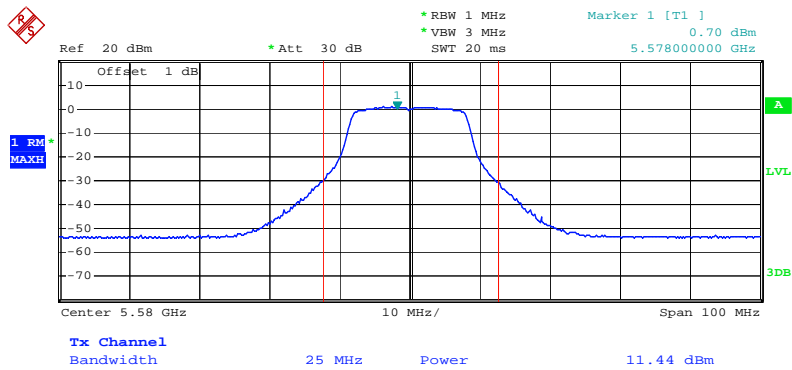

Date: 24.JUN.2009 21:29:27

Conducted Output Power Plot on Configuration IEEE 802.11a Ant. 2-3 / 5700 MHz

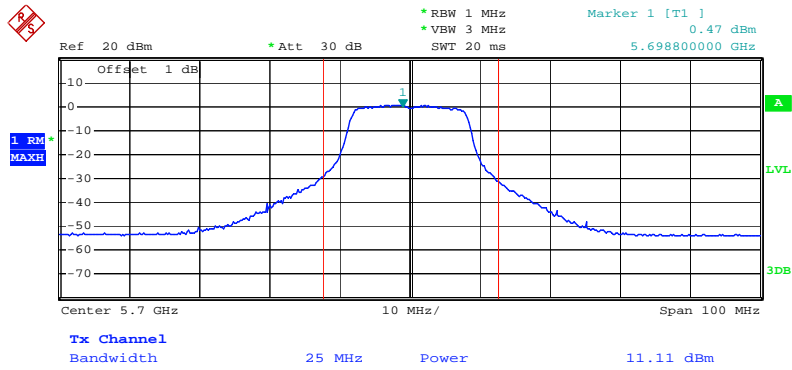

Date: 24.JUN.2009 21:37:36

<For Antenna 3>:

Conducted Output Power Plot on Configuration Draft n MCS0 20MHz Ant. 3-1 / 5260 MHz

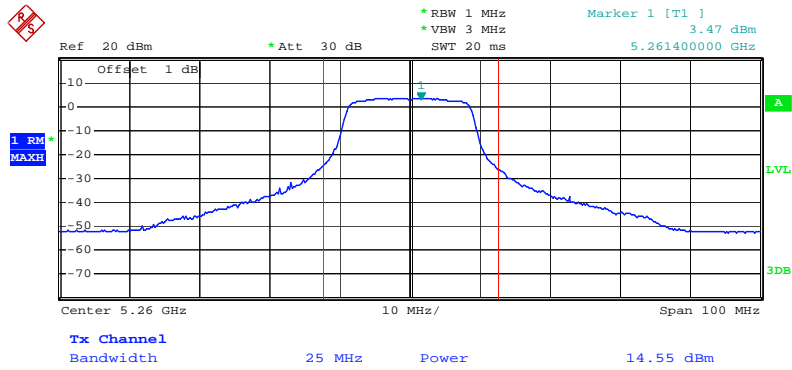

Date: 25.JUN.2009 19:54:28

Conducted Output Power Plot on Configuration Draft n MCS0 20MHz Ant. 3-1 / 5300 MHz

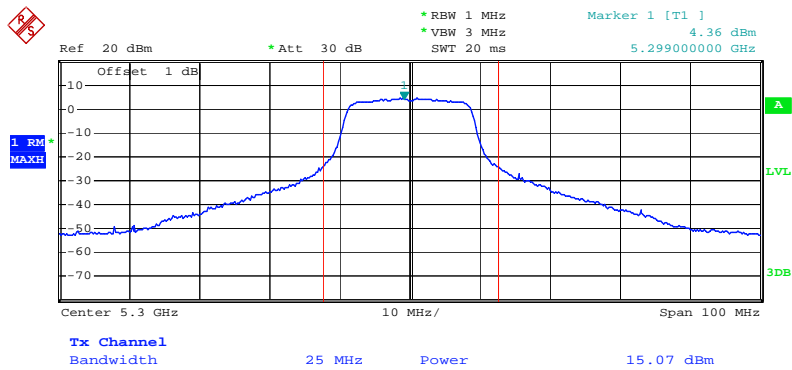

Date: 25.JUN.2009 20:03:15

Conducted Output Power Plot on Configuration Draft n MCS0 20MHz Ant. 3-1 / 5320 MHz

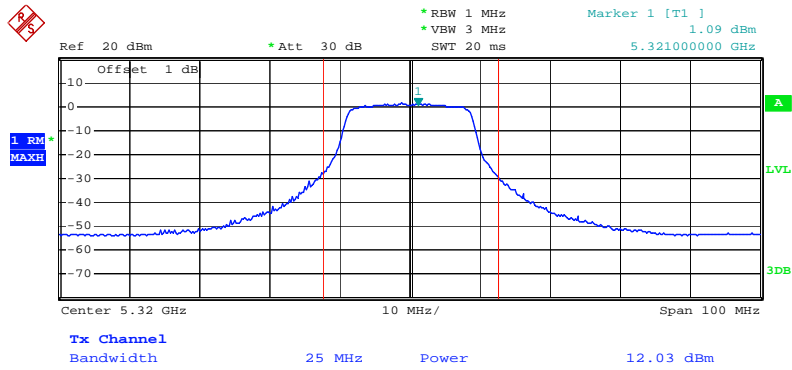

Date: 24.JUN.2009 22:31:24

Conducted Output Power Plot on Configuration Draft n MCS0 20MHz Ant. 3-1 / 5500 MHz

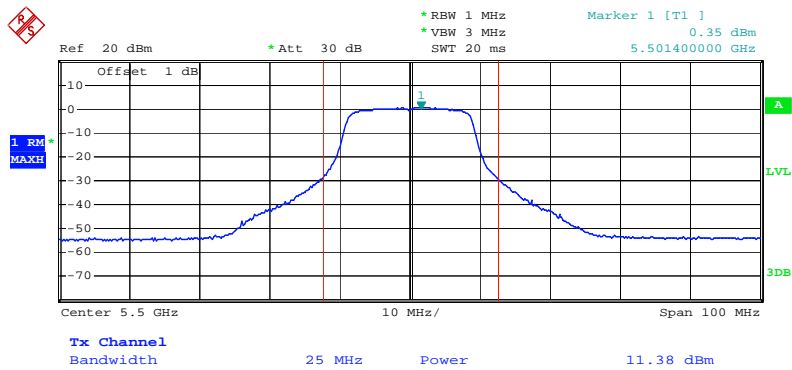

Date: 24.JUN.2009 22:38:29

Conducted Output Power Plot on Configuration Draft n MCS0 20MHz Ant. 3-1 / 5580 MHz

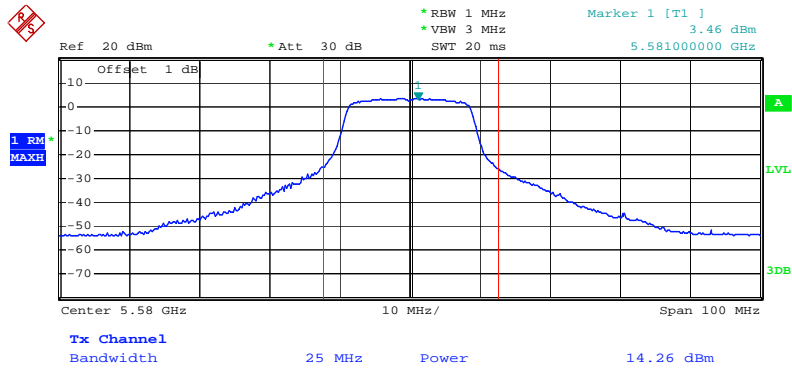

Date: 25.JUN.2009 20:10:38

Conducted Output Power Plot on Configuration Draft n MCS0 20MHz Ant. 3-1 / 5700 MHz

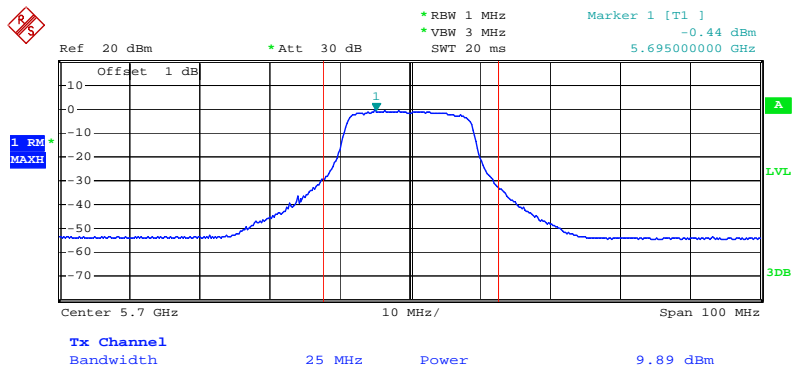

Date: 25.JUN.2009 20:24:31

Conducted Output Power Plot on Configuration Draft n MCS0 20MHz Ant. 3-2 / 5320 MHz

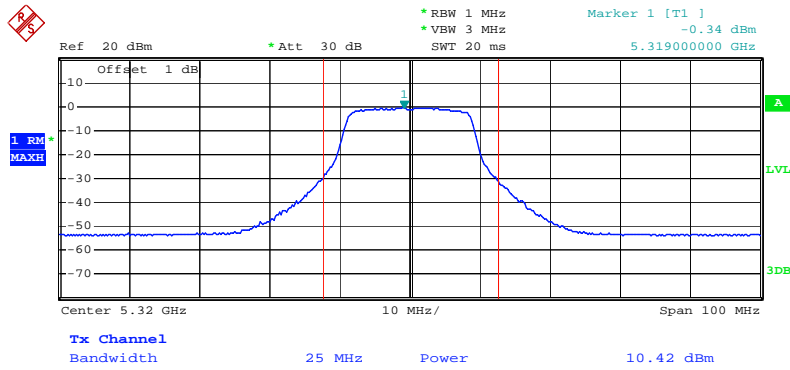

Date: 24.JUN.2009 22:33:00

Conducted Output Power Plot on Configuration Draft n MCS0 20MHz Ant. 3-2 / 5500 MHz

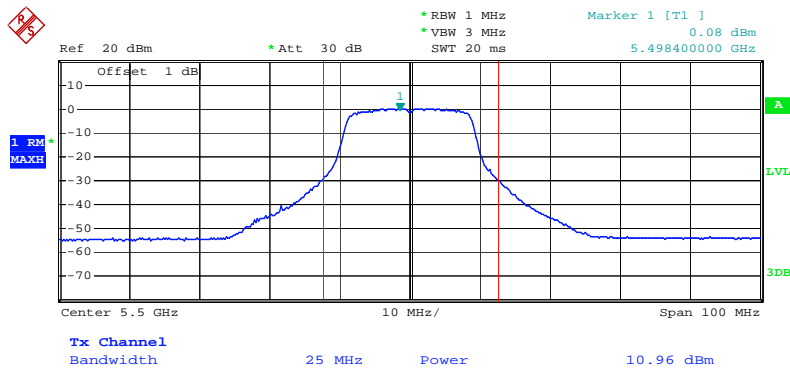

Date: 24.JUN.2009 22:37:22

Conducted Output Power Plot on Configuration Draft n MCS0 20MHz Ant. 3-2 / 5580 MHz

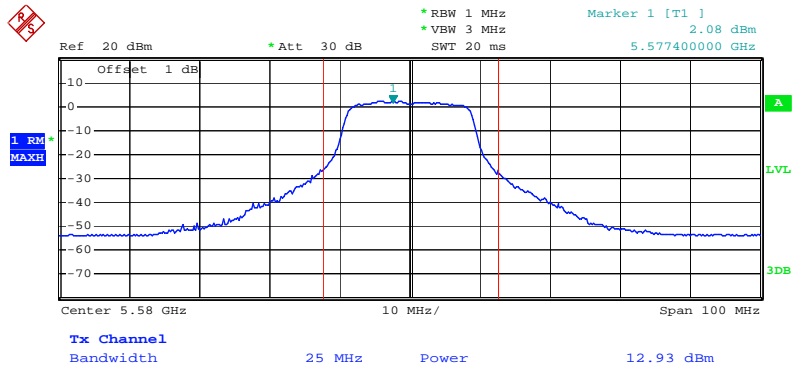

Date: 25.JUN.2009 20:14:17

Conducted Output Power Plot on Configuration Draft n MCS0 20MHz Ant. 3-2 / 5700 MHz

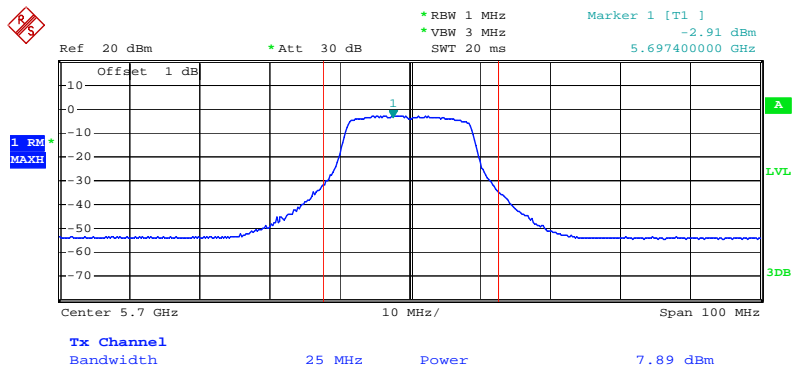

Date: 25.JUN.2009 20:23:09

Conducted Output Power Plot on Configuration Draft n MCS0 20MHz Ant. 3-3 / 5260 MHz

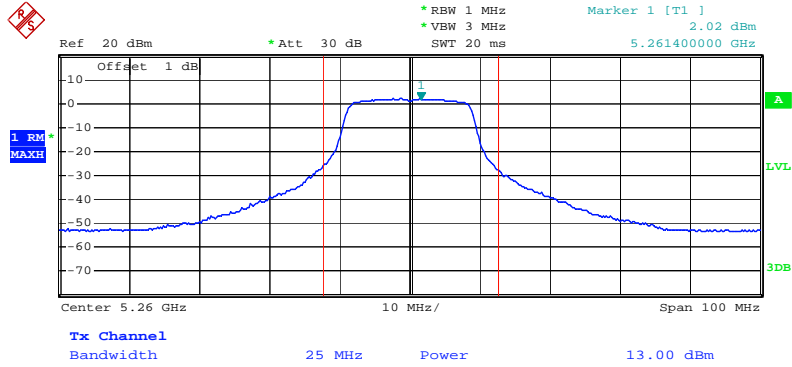

Date: 25.JUN.2009 19:57:35

Conducted Output Power Plot on Configuration Draft n MCS0 20MHz Ant. 3-3 / 5300 MHz

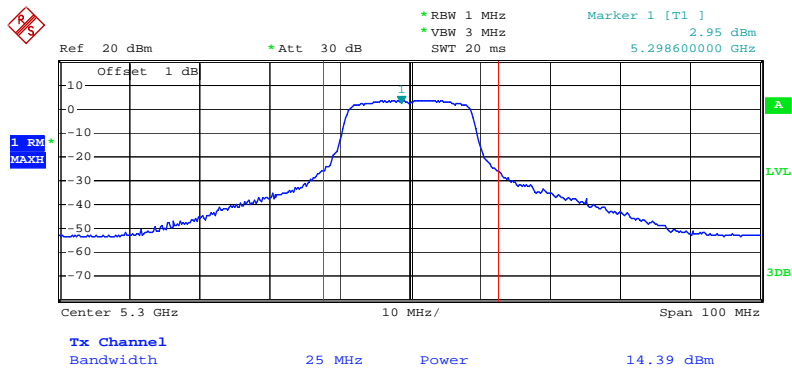

Date: 25.JUN.2009 19:59:44

Conducted Output Power Plot on Configuration Draft n MCS0 20MHz Ant. 3-3 / 5320 MHz

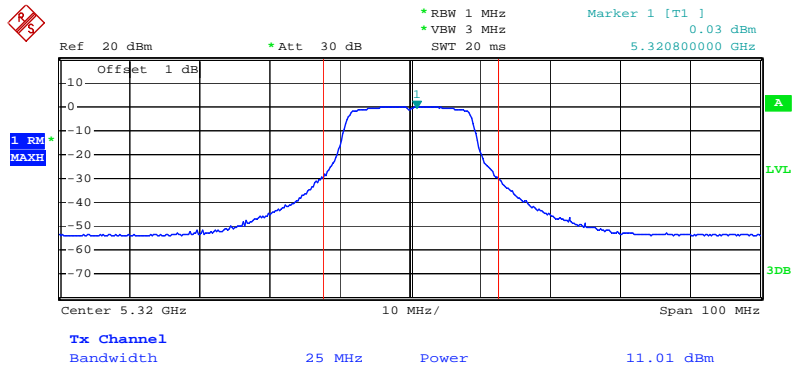

Date: 24.JUN.2009 22:28:30

Conducted Output Power Plot on Configuration Draft n MCS0 20MHz Ant. 3-3 / 5500 MHz

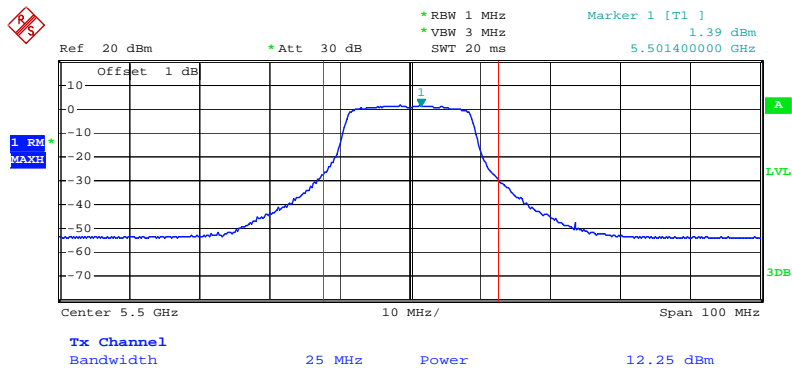

Date: 24.JUN.2009 22:35:44

Conducted Output Power Plot on Configuration Draft n MCS0 20MHz Ant. 3-3 / 5580 MHz

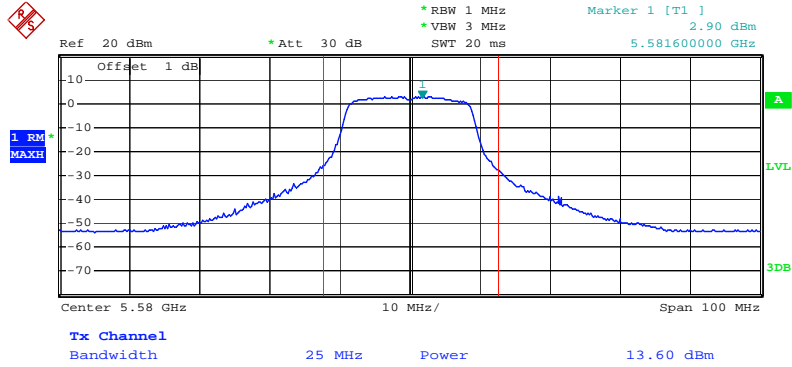

Date: 25.JUN.2009 20:17:50

Conducted Output Power Plot on Configuration Draft n MCS0 20MHz Ant. 3-3 / 5700 MHz

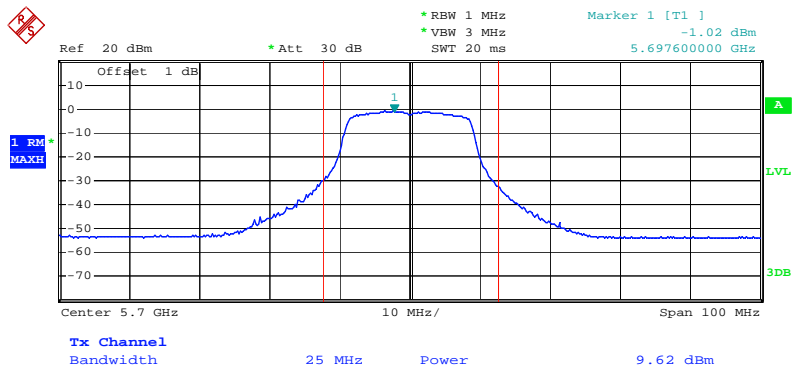

Date: 25.JUN.2009 20:21:00

Conducted Output Power Plot on Configuration Draft n MCS0 40MHz Ant. 3-1 / 5270 MHz

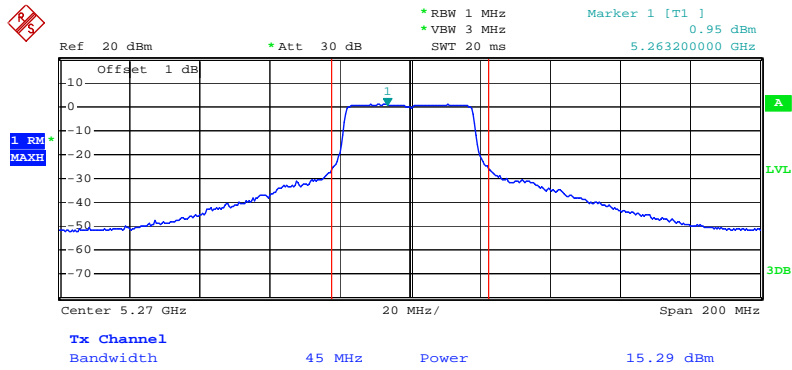

Date: 25.JUN.2009 20:49:33

Conducted Output Power Plot on Configuration Draft n MCS0 40MHz Ant. 3-1 / 5310 MHz

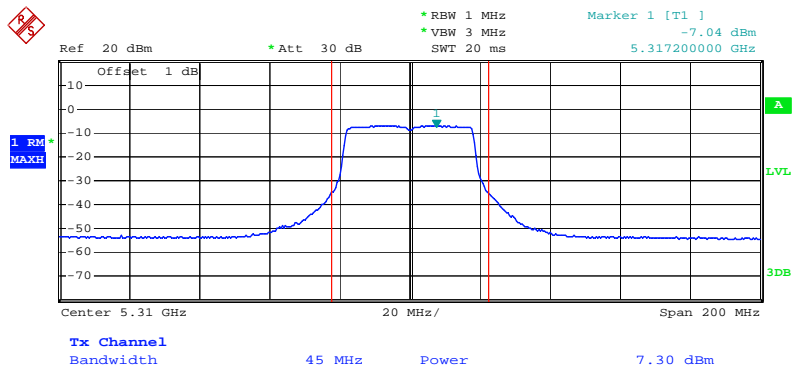

Date: 25.JUN.2009 20:50:57

Conducted Output Power Plot on Configuration Draft n MCS0 40MHz Ant. 3-1 / 5510MHz

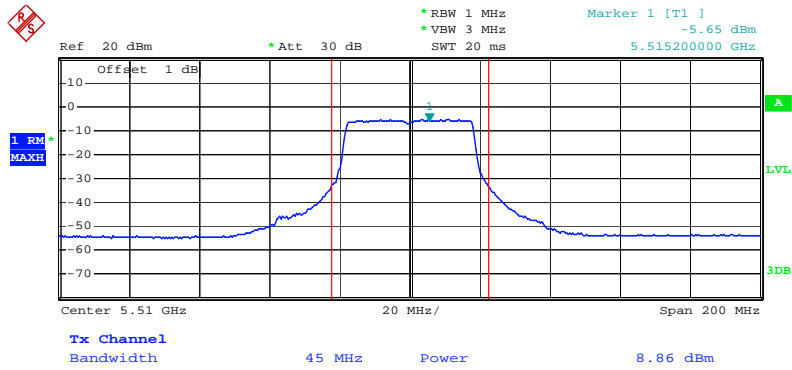

Date: 25.JUN.2009 20:57:43

Conducted Output Power Plot on Configuration Draft n MCS0 40MHz Ant. 3-2 / 5550 MHz

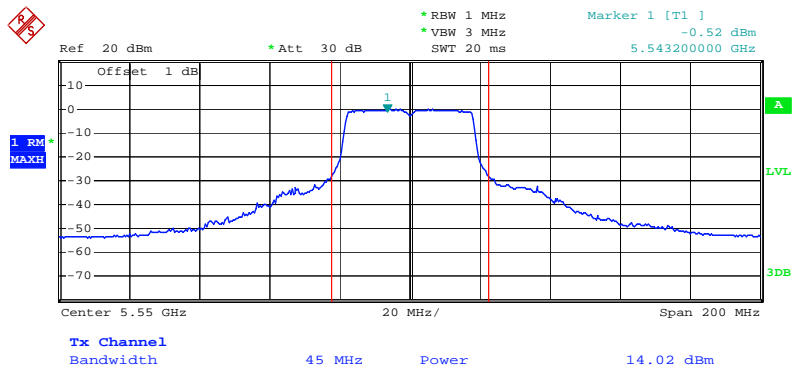

Date: 25.JUN.2009 21:05:33

Conducted Output Power Plot on Configuration Draft n MCS0 40MHz Ant. 3-2 / 5670 MHz

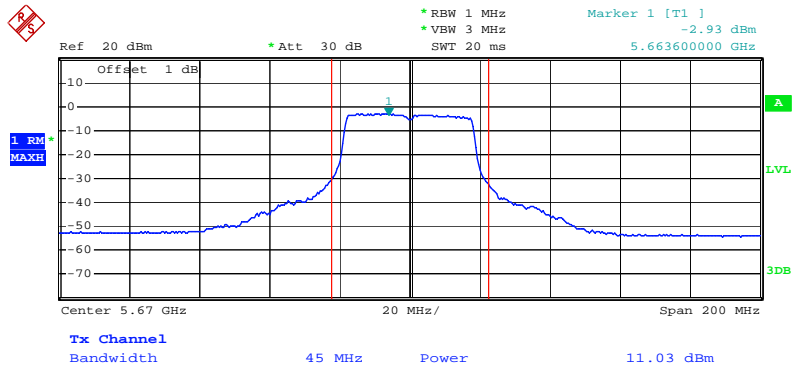

Date: 25.JUN.2009 21:14:06

Conducted Output Power Plot on Configuration Draft n MCS0 40MHz Ant. 3-2 / 5270 MHz

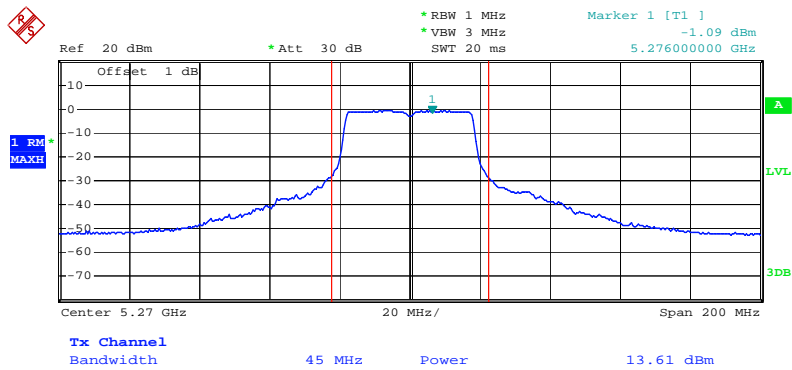

Date: 25.JUN.2009 20:47:43

Conducted Output Power Plot on Configuration Draft n MCS0 40MHz Ant. 3-2 / 5310 MHz

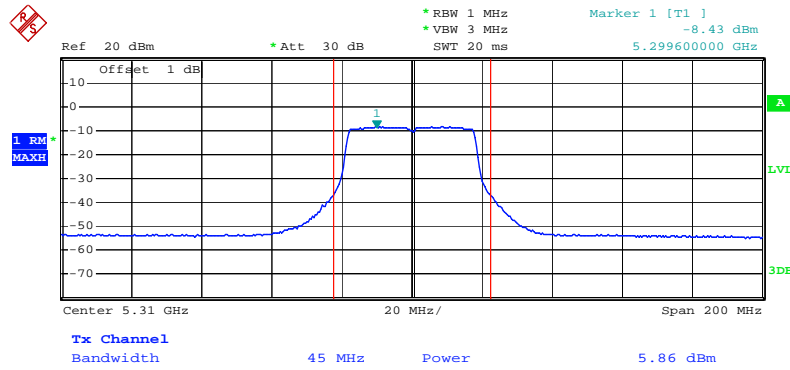

Date: 25.JUN.2009 20:51:46

Conducted Output Power Plot on Configuration Draft n MCS0 40MHz Ant. 3-2 / 5510MHz

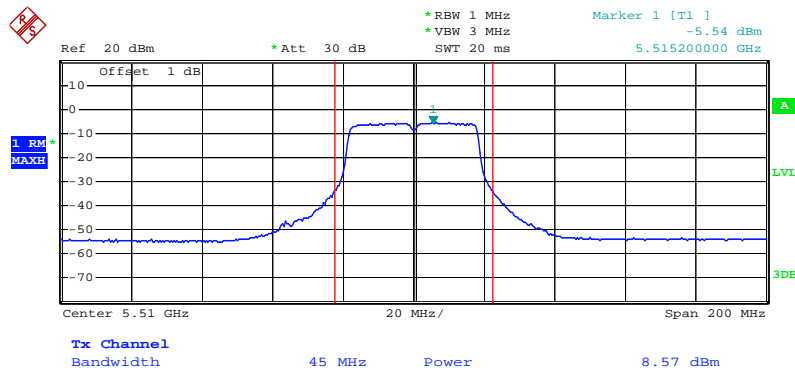

Date: 25.JUN.2009 20:56:20

Conducted Output Power Plot on Configuration Draft n MCS0 40MHz Ant. 3-2 / 5550 MHz

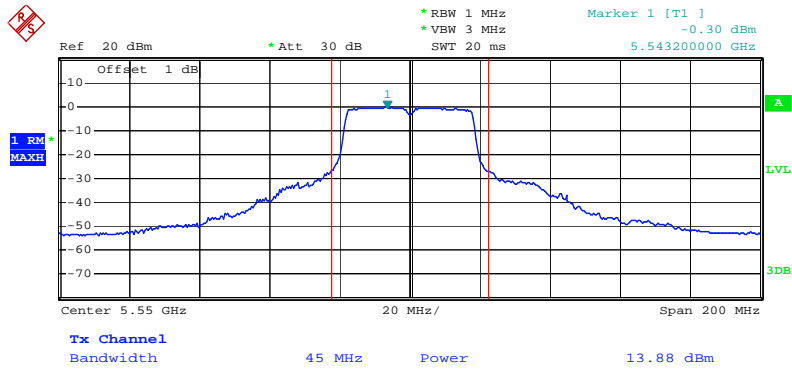

Date: 25.JUN.2009 21:04:10

Conducted Output Power Plot on Configuration Draft n MCS0 40MHz Ant. 3-2 / 5670 MHz

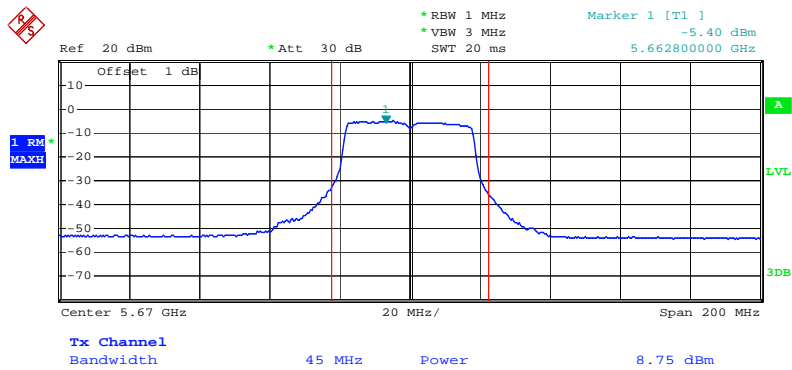

Date: 25.JUN.2009 21:12:41

Conducted Output Power Plot on Configuration Draft n MCS0 40MHz Ant. 3-3 / 5270 MHz

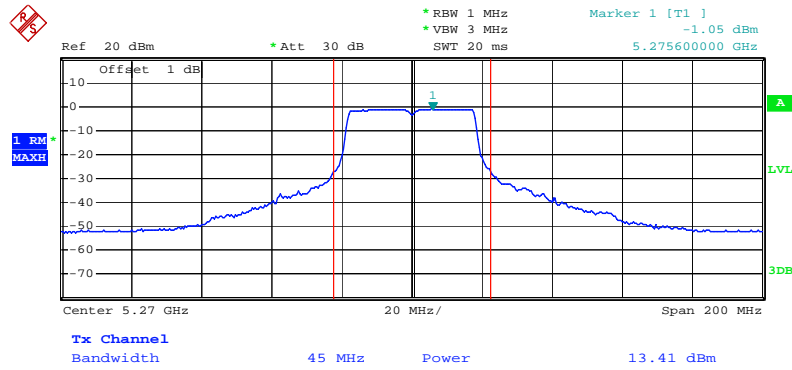

Date: 25.JUN.2009 20:46:35

Conducted Output Power Plot on Configuration Draft n MCS0 40MHz Ant. 3-3 / 5310 MHz

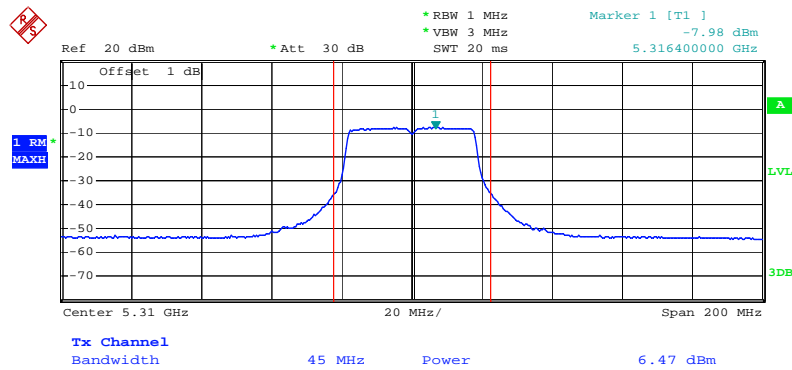

Date: 25.JUN.2009 20:53:17

Conducted Output Power Plot on Configuration Draft n MCS0 40MHz Ant. 3-3 / 5510MHz

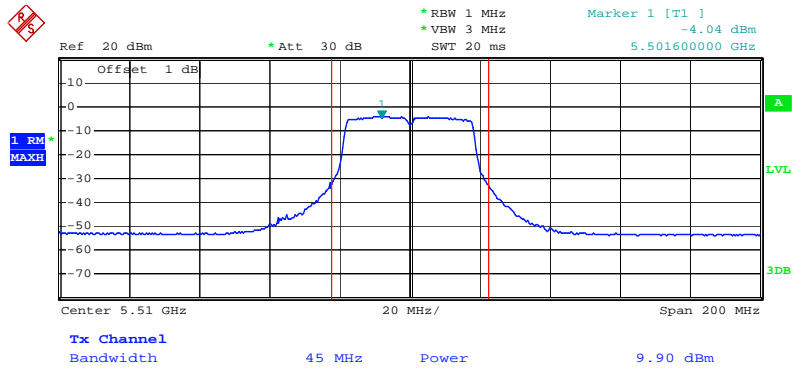

Date: 25.JUN.2009 20:55:13

Conducted Output Power Plot on Configuration Draft n MCS0 40MHz Ant. 3-3 / 5550 MHz

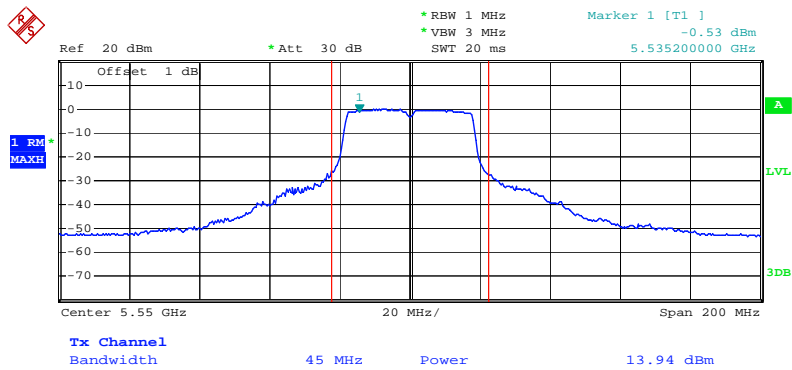

Date: 25.JUN.2009 21:07:58

Conducted Output Power Plot on Configuration Draft n MCS0 40MHz Ant. 3-3 / 5670 MHz

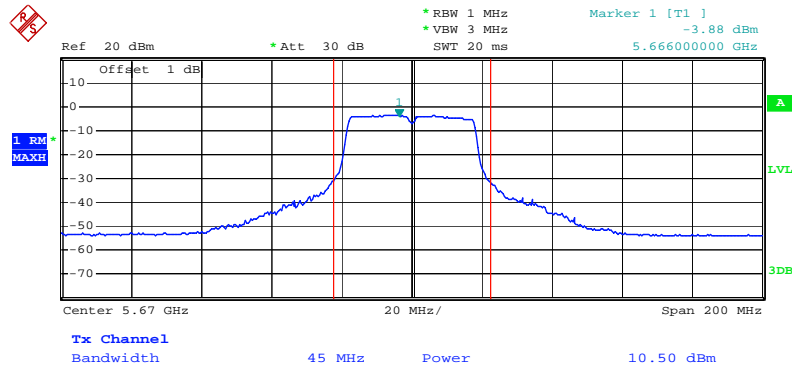

Date: 25.JUN.2009 21:11:41

Conducted Output Power Plot on Configuration IEEE 802.11a Ant. 3-1 / 5260 MHz

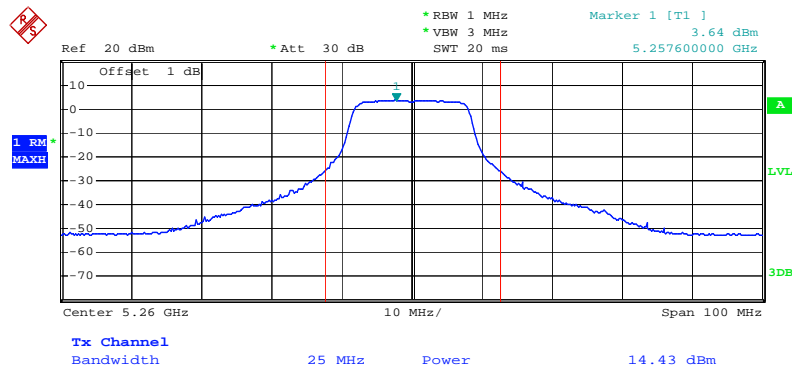

Date: 25.JUN.2009 12:01:50

Conducted Output Power Plot on Configuration IEEE 802.11a Ant. 3-1 / 5300 MHz

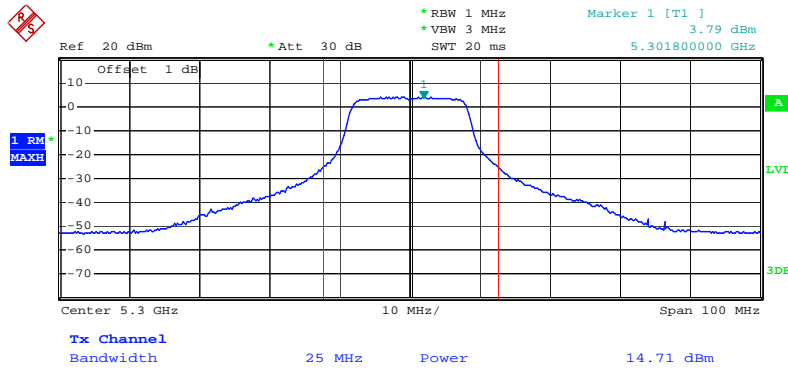

Date: 25.JUN.2009 18:29:35

Conducted Output Power Plot on Configuration IEEE 802.11a Ant. 3-1 / 5320 MHz

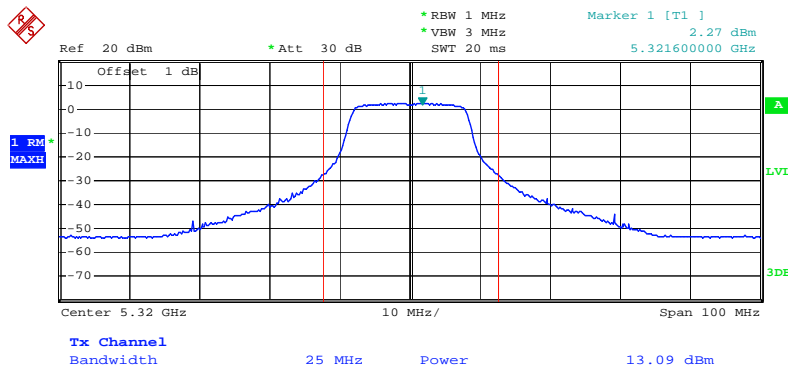

Date: 25.JUN.2009 18:58:01

Conducted Output Power Plot on Configuration IEEE 802.11a Ant. 3-1 / 5500 MHz

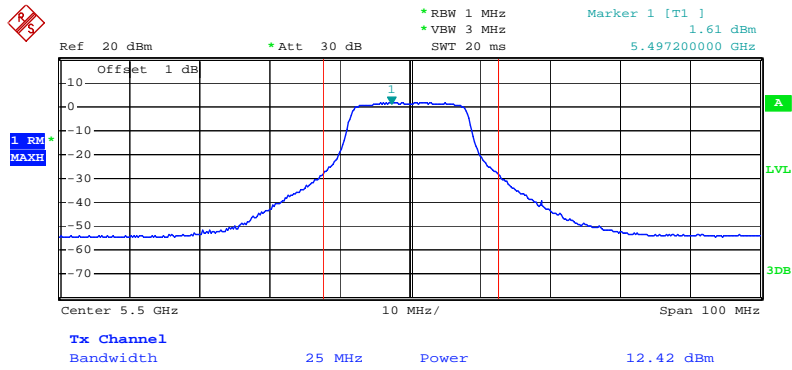

Date: 25.JUN.2009 19:00:24

Conducted Output Power Plot on Configuration IEEE 802.11a Ant. 3-1 / 5580 MHz

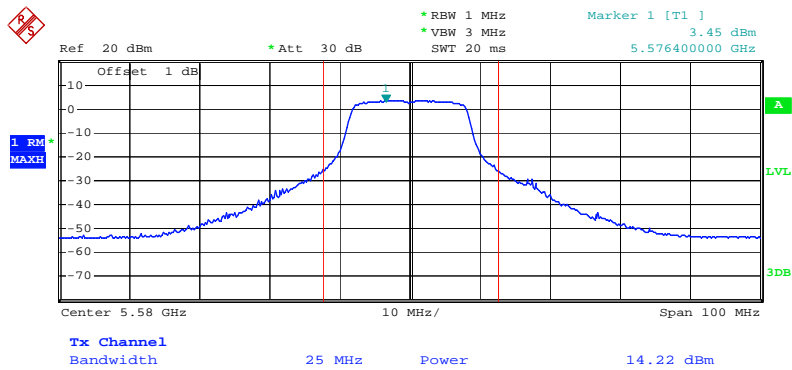

Date: 25.JUN.2009 19:19:22

Conducted Output Power Plot on Configuration IEEE 802.11a Ant. 3-1 / 5700 MHz

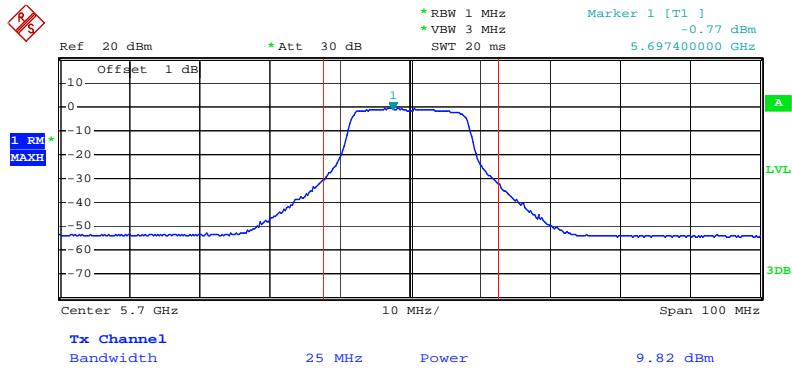

Date: 25.JUN.2009 19:20:51

Conducted Output Power Plot on Configuration IEEE 802.11a Ant. 3-2 / 5260 MHz

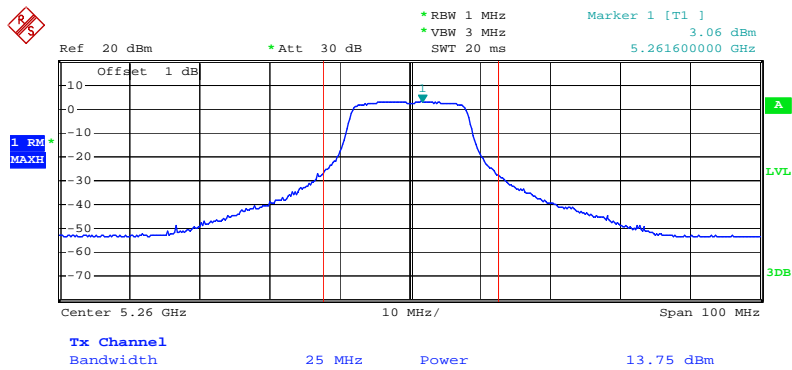

Date: 25.JUN.2009 12:05:03

Conducted Output Power Plot on Configuration IEEE 802.11a Ant. 3-2 / 5300 MHz

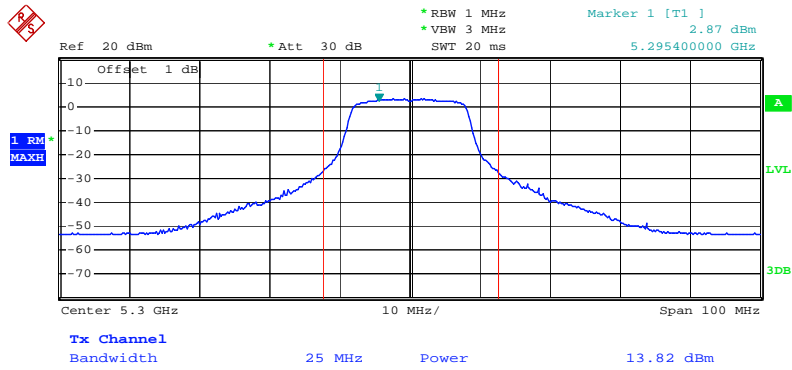

Date: 25.JUN.2009 18:34:42

Conducted Output Power Plot on Configuration IEEE 802.11a Ant. 3-2 / 5320 MHz

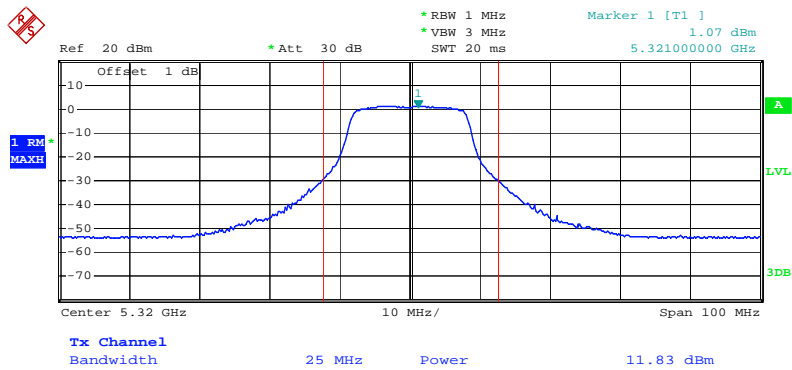

Date: 25.JUN.2009 18:56:32

Conducted Output Power Plot on Configuration IEEE 802.11a Ant. 3-2 / 5500 MHz

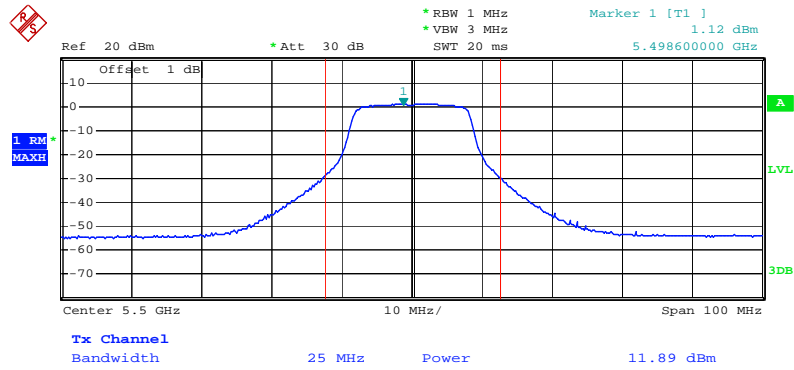

Date: 25.JUN.2009 19:01:46

Conducted Output Power Plot on Configuration IEEE 802.11a Ant. 3-2 / 5580 MHz

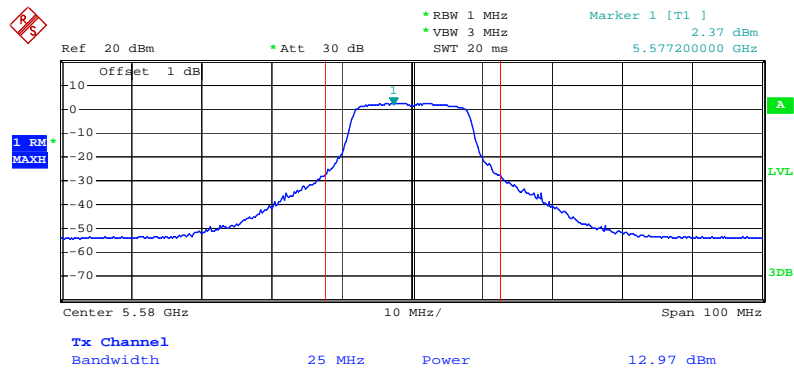

Date: 25.JUN.2009 19:13:48

Conducted Output Power Plot on Configuration IEEE 802.11a Ant. 3-2 / 5700 MHz

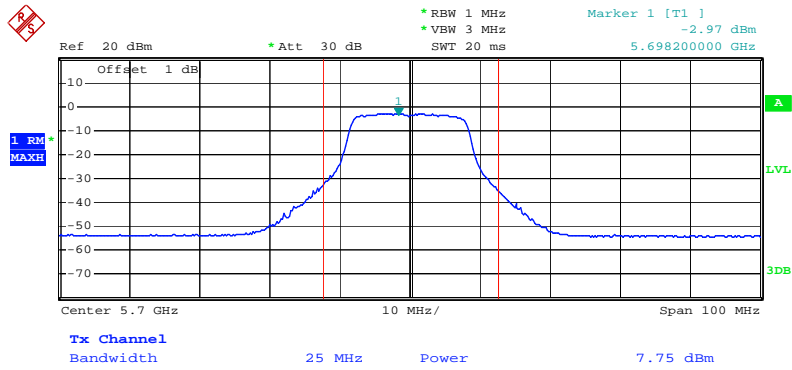

Date: 25.JUN.2009 19:22:12

Conducted Output Power Plot on Configuration IEEE 802.11a Ant. 3-3 / 5260 MHz

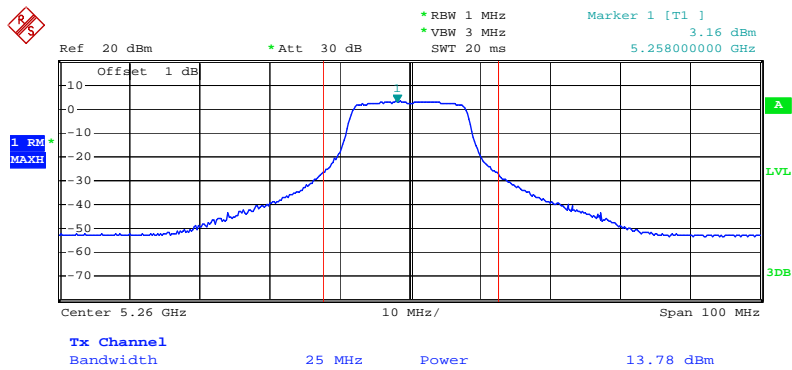

Date: 25.JUN.2009 12:09:40

Conducted Output Power Plot on Configuration IEEE 802.11a Ant. 3-3 / 5300 MHz

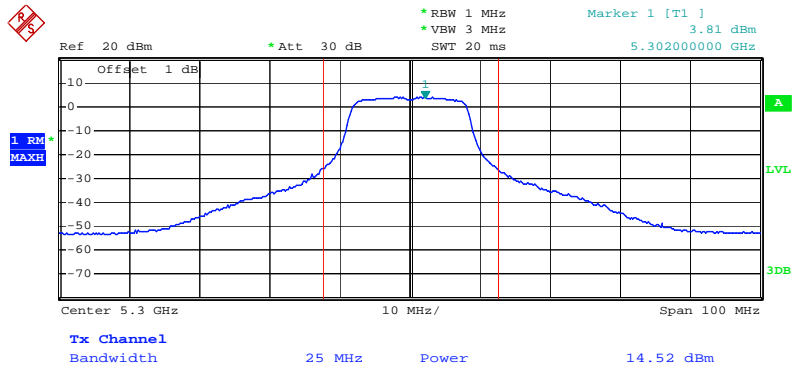

Date: 25.JUN.2009 18:36:14

Conducted Output Power Plot on Configuration IEEE 802.11a Ant. 3-3 / 5320 MHz

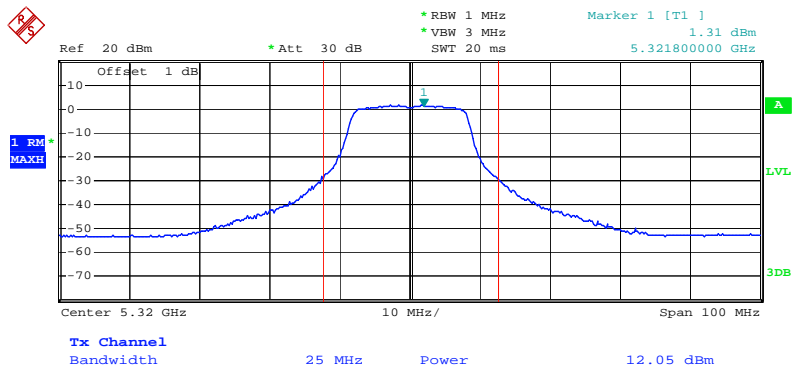

Date: 25.JUN.2009 18:54:49

Conducted Output Power Plot on Configuration IEEE 802.11a Ant. 3-3 / 5500 MHz

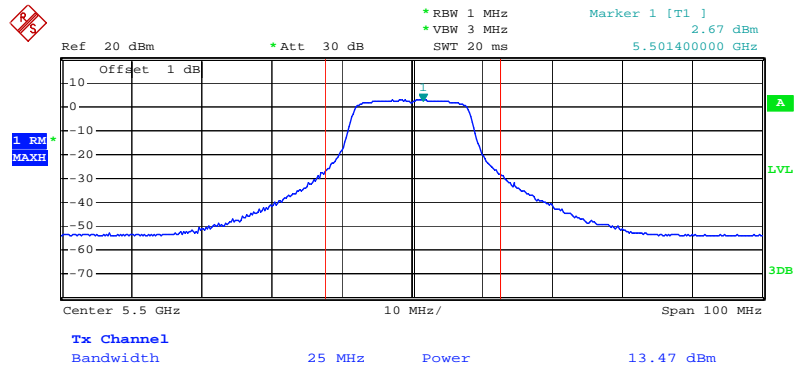

Date: 25.JUN.2009 19:03:16

Conducted Output Power Plot on Configuration IEEE 802.11a Ant. 3-3 / 5580 MHz

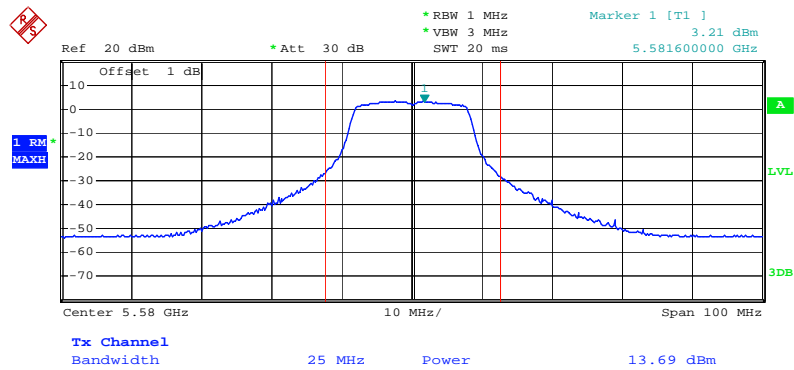

Date: 25.JUN.2009 19:17:42

Conducted Output Power Plot on Configuration IEEE 802.11a Ant. 3-3 / 5700 MHz

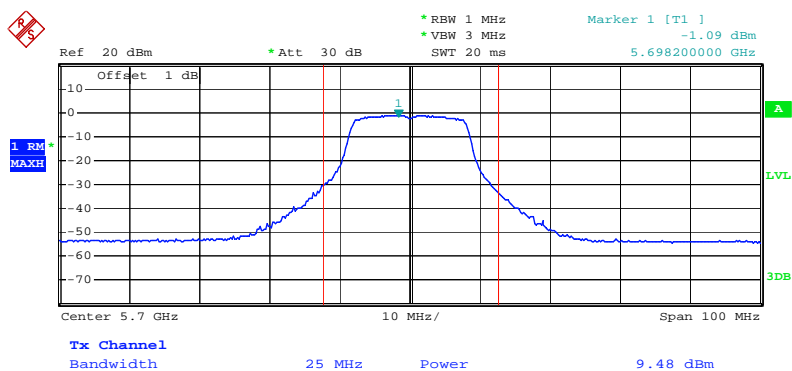

Date: 25.JUN.2009 19:23:12

<For Antenna 4>:

Conducted Output Power Plot on Configuration Draft n MCS0 20MHz Ant. 4-1 / 5260 MHz

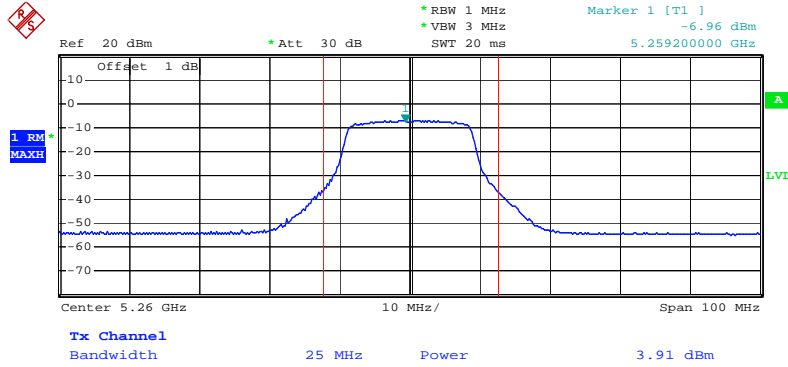

Date: 17.JUL.2009 16:34:33

Conducted Output Power Plot on Configuration Draft n MCS0 20MHz Ant. 4-1 / 5300 MHz

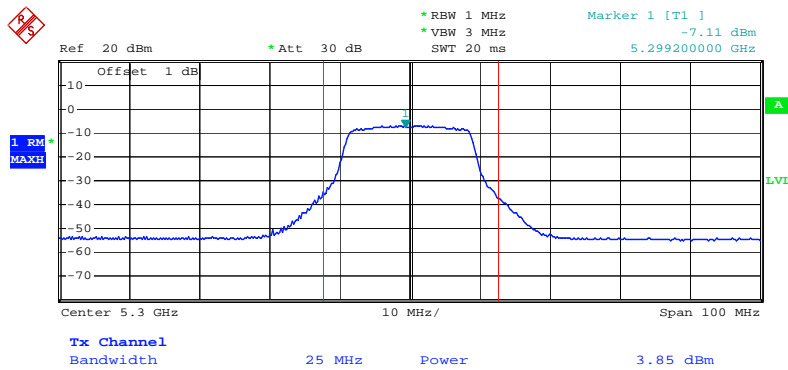

Date: 17.JUL.2009 16:38:10

Conducted Output Power Plot on Configuration Draft n MCS0 20MHz Ant. 4-1 / 5320 MHz

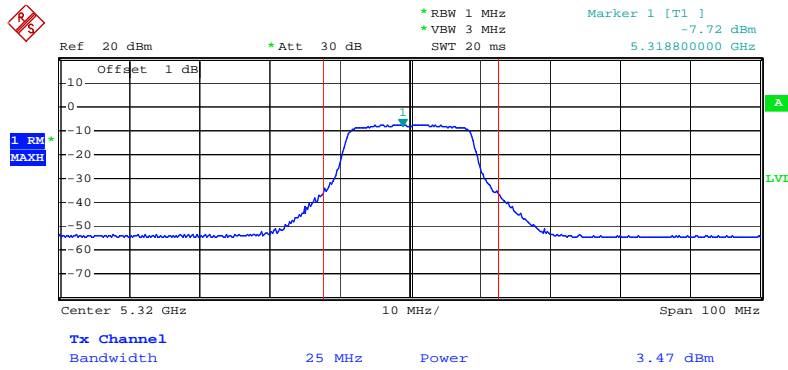

Date: 17.JUL.2009 16:39:28

Conducted Output Power Plot on Configuration Draft n MCS0 20MHz Ant. 4-1 / 5500 MHz

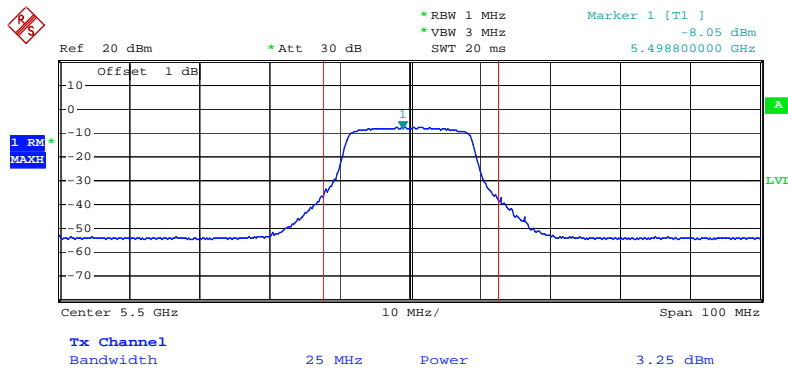

Date: 17.JUL.2009 16:43:30

Conducted Output Power Plot on Configuration Draft n MCS0 20MHz Ant. 4-3 / 5260 MHz

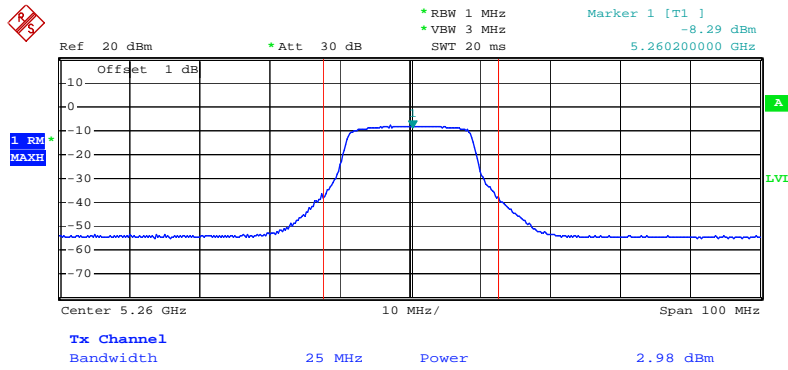

Date: 17.JUL.2009 16:35:57

Conducted Output Power Plot on Configuration Draft n MCS0 20MHz Ant. 4-3 / 5300 MHz

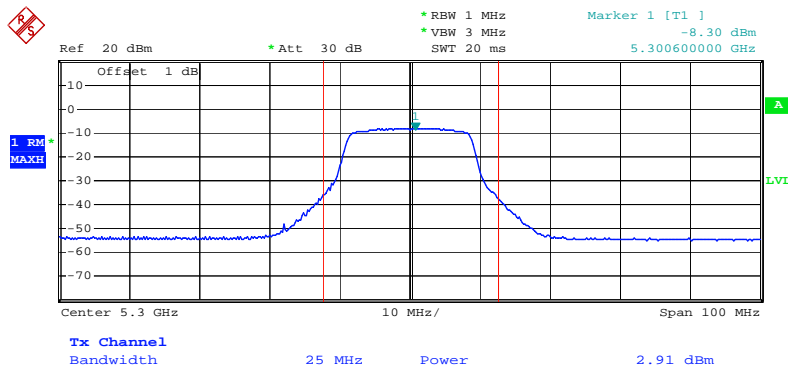

Date: 17.JUL.2009 16:37:34

Conducted Output Power Plot on Configuration Draft n MCS0 20MHz Ant. 4-3 / 5320 MHz

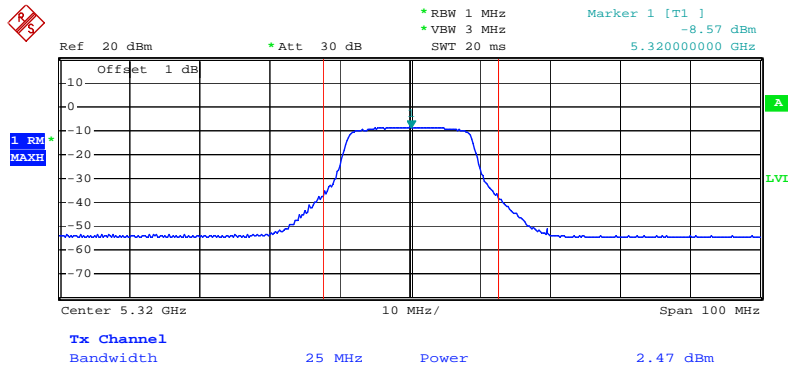

Date: 17.JUL.2009 16:41:18

Conducted Output Power Plot on Configuration Draft n MCS0 20MHz Ant. 4-3 / 5500 MHz

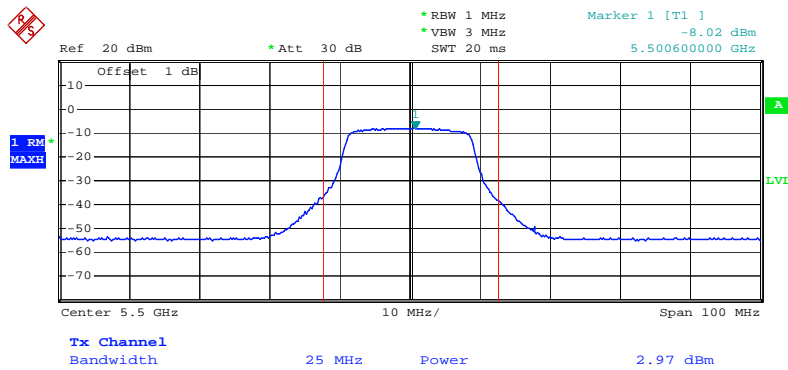

Date: 17.JUL.2009 16:42:23

Conducted Output Power Plot on Configuration Draft n MCS0 20MHz Ant. 4-3 / 5580 MHz

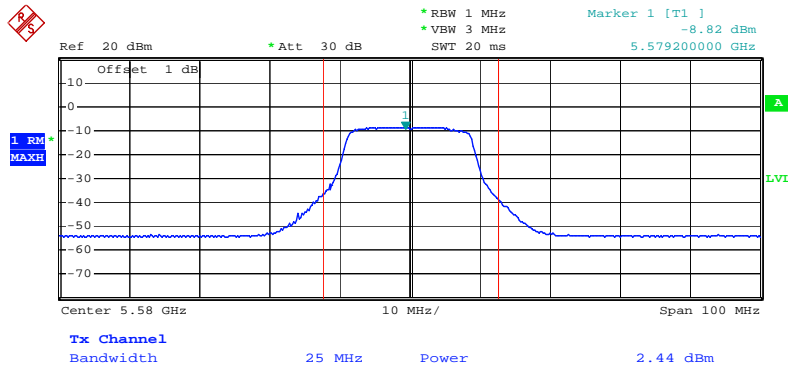

Date: 17.JUL.2009 16:47:39

Conducted Output Power Plot on Configuration Draft n MCS0 20MHz Ant. 4-3 / 5700 MHz

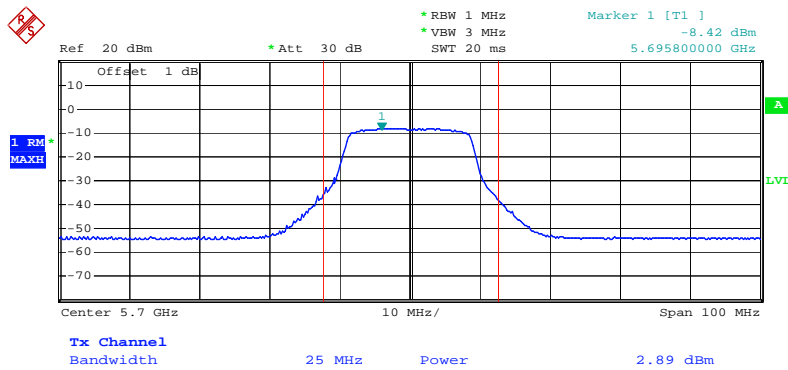

Date: 17.JUL.2009 16:57:51

Conducted Output Power Plot on Configuration Draft n MCS0 40MHz Ant. 4-1 / 5270 MHz

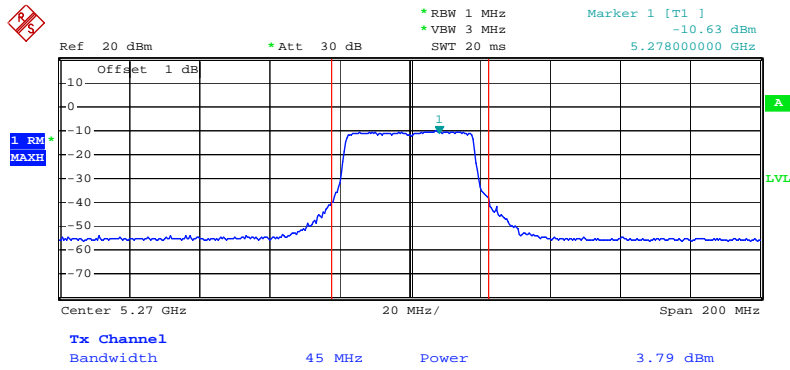

Date: 17.JUL.2009 17:06:04

Conducted Output Power Plot on Configuration Draft n MCS0 40MHz Ant. 4-1 / 5310 MHz

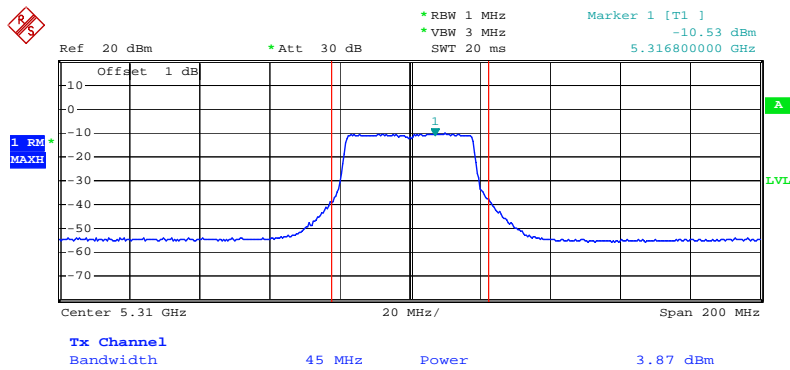

Date: 17.JUL.2009 17:12:06

Conducted Output Power Plot on Configuration Draft n MCS0 40MHz Ant. 4-1 / 5510MHz

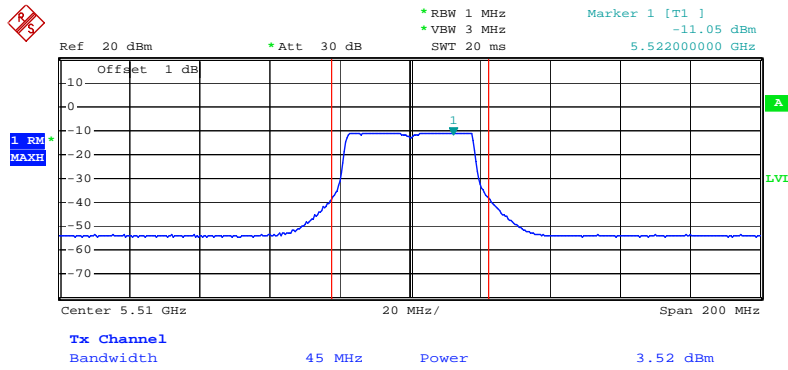

Date: 17.JUL.2009 17:23:40

Conducted Output Power Plot on Configuration Draft n MCS0 40MHz Ant. 4-3 / 5550 MHz

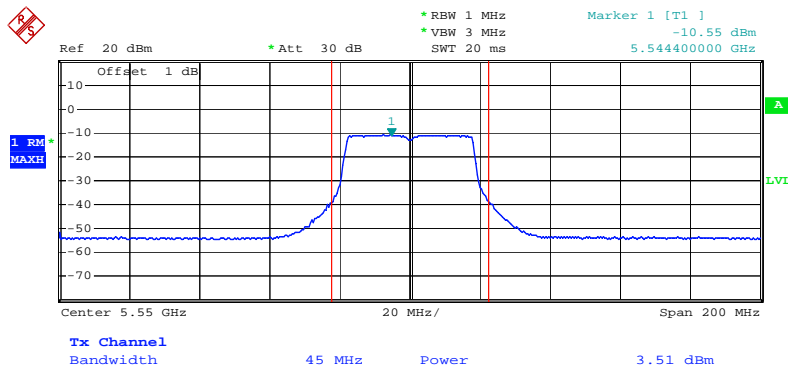

Date: 17.JUL.2009 17:30:55

Conducted Output Power Plot on Configuration Draft n MCS0 40MHz Ant. 4-1 / 5670 MHz

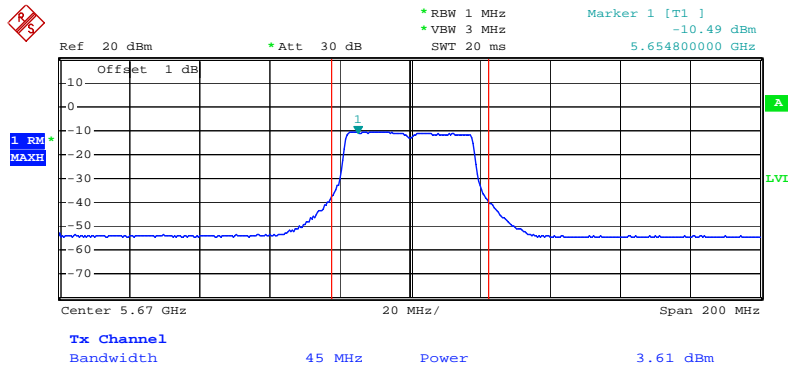

Date: 17.JUL.2009 17:32:32

Conducted Output Power Plot on Configuration Draft n MCS0 40MHz Ant. 4-3 / 5270 MHz

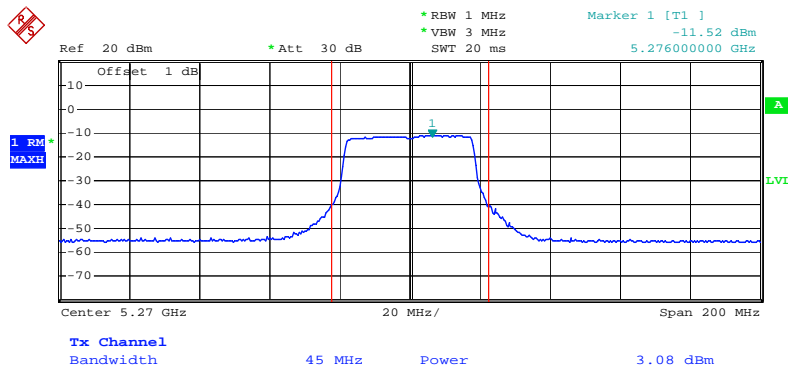

Date: 17.JUL.2009 17:07:49

Conducted Output Power Plot on Configuration Draft n MCS0 40MHz Ant. 4-3 / 5310 MHz

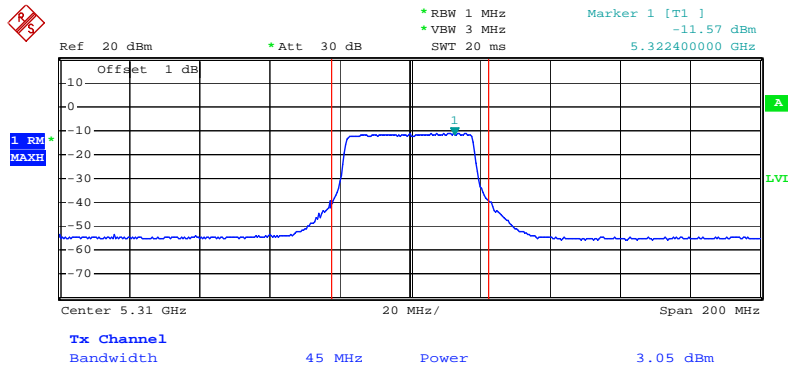

Date: 17.JUL.2009 17:12:43

Conducted Output Power Plot on Configuration Draft n MCS0 40MHz Ant. 4-3 / 5510MHz

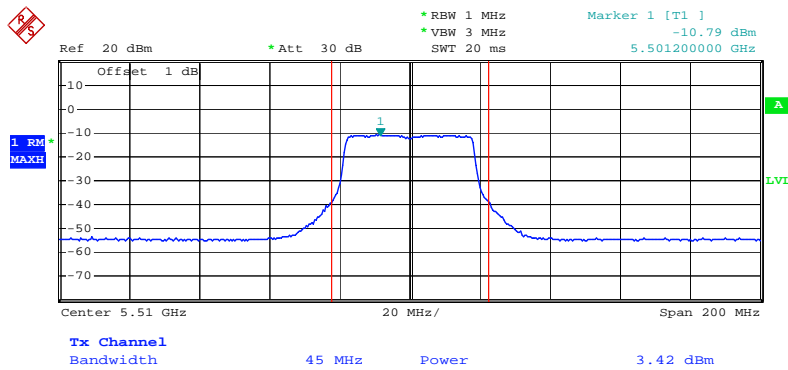

Date: 17.JUL.2009 17:21:13

Conducted Output Power Plot on Configuration Draft n MCS0 40MHz Ant. 4-3 / 5550 MHz

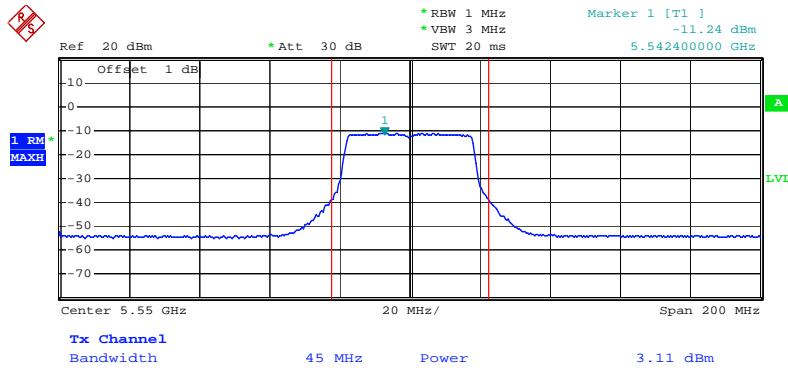

Date: 17.JUL.2009 17:29:02

Conducted Output Power Plot on Configuration Draft n MCS0 40MHz Ant. 4-3 / 5670 MHz

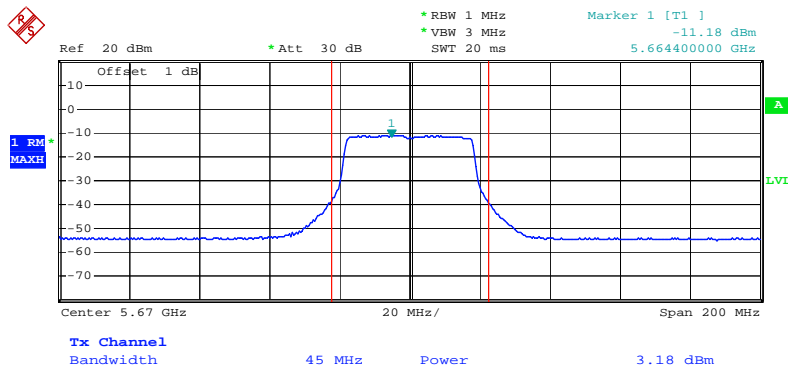

Date: 17.JUL.2009 17:33:38

Conducted Output Power Plot on Configuration IEEE 802.11a Ant. 4-1 / 5260 MHz

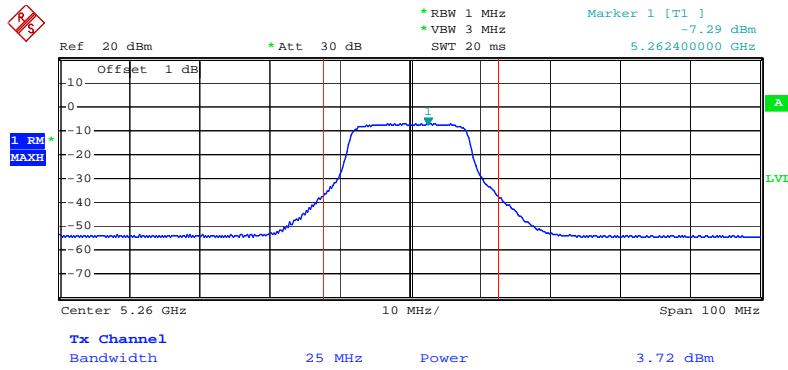

Date: 17.JUL.2009 16:05:45

Conducted Output Power Plot on Configuration IEEE 802.11a Ant. 4-1 / 5300 MHz

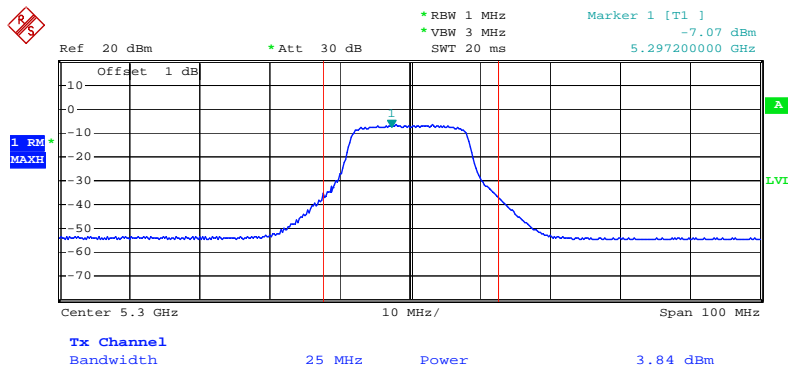

Date: 17.JUL.2009 16:07:52

Conducted Output Power Plot on Configuration IEEE 802.11a Ant. 4-1 / 5320 MHz

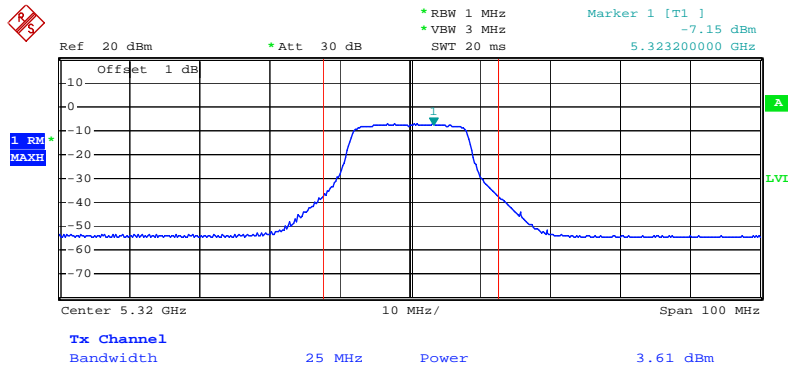

Date: 17.JUL.2009 16:12:04

Conducted Output Power Plot on Configuration IEEE 802.11a Ant. 4-1 / 5500 MHz

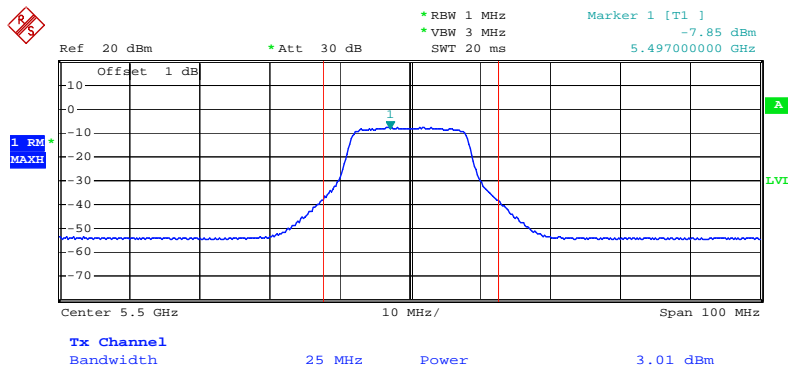

Date: 17.JUL.2009 16:16:33

Conducted Output Power Plot on Configuration IEEE 802.11a Ant. 4-1 / 5580 MHz

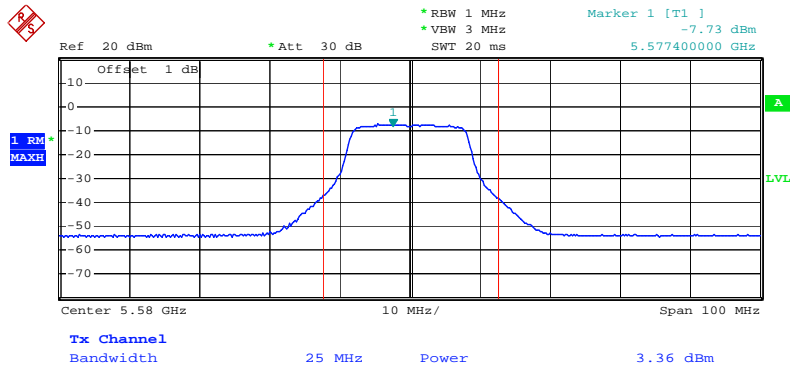

Date: 17.JUL.2009 16:24:20

Conducted Output Power Plot on Configuration IEEE 802.11a Ant. 4-1 / 5700 MHz

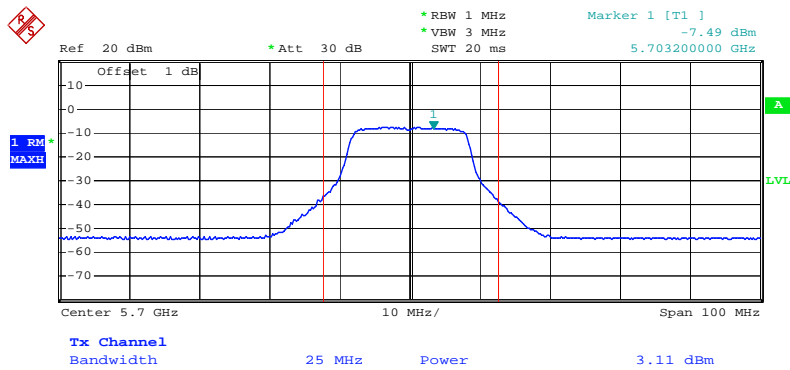

Date: 17.JUL.2009 16:33:07

Conducted Output Power Plot on Configuration IEEE 802.11a Ant. 4-3 / 5260 MHz

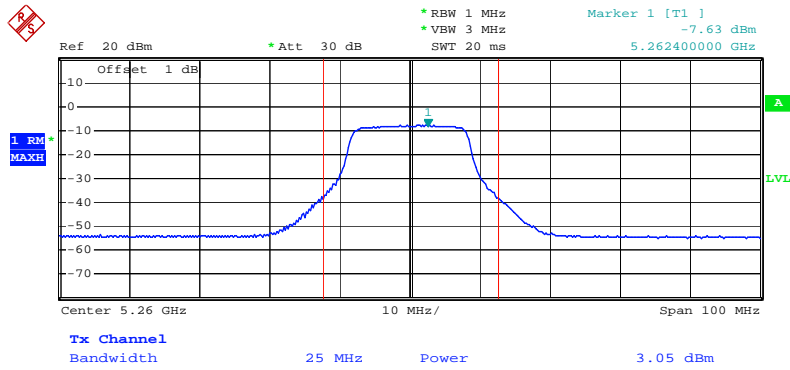

Date: 17.JUL.2009 16:05:04

Conducted Output Power Plot on Configuration IEEE 802.11a Ant. 4-3 / 5300 MHz

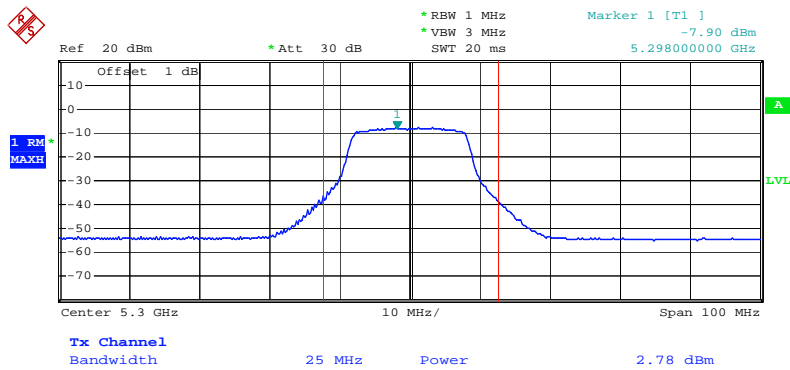

Date: 17.JUL.2009 16:09:07

Conducted Output Power Plot on Configuration IEEE 802.11a Ant. 4-3 / 5320 MHz

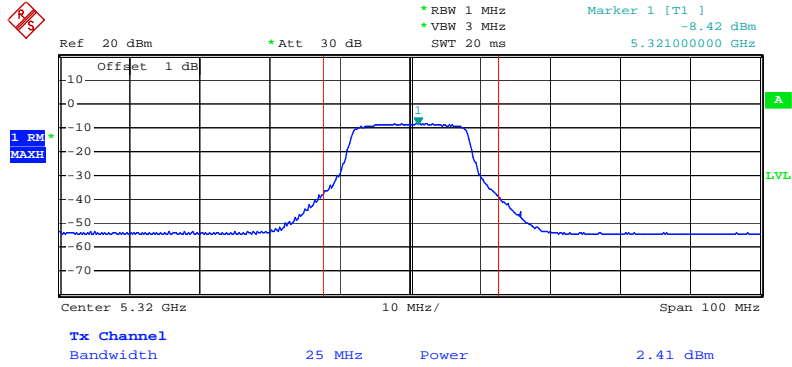

Date: 17.JUL.2009 16:14:19

Conducted Output Power Plot on Configuration IEEE 802.11a Ant. 4-3 / 5500 MHz

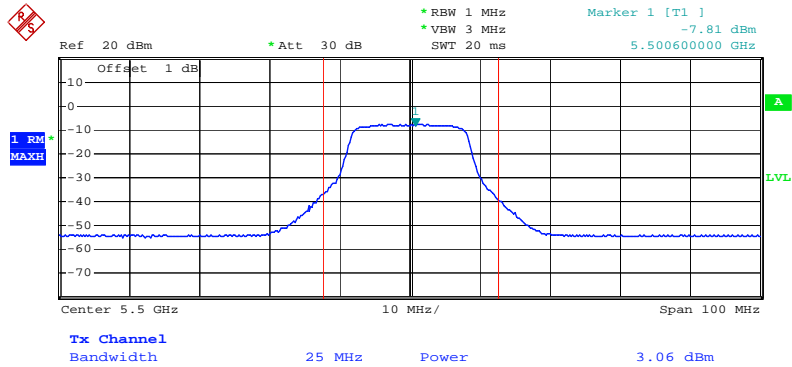

Date: 17.JUL.2009 16:18:11

Conducted Output Power Plot on Configuration IEEE 802.11a Ant. 4-3 / 5580 MHz

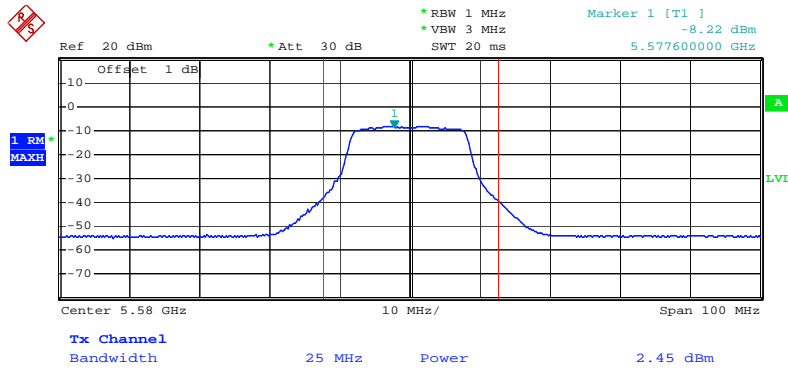

Date: 17.JUL.2009 16:22:27

Conducted Output Power Plot on Configuration IEEE 802.11a Ant. 4-3 / 5700 MHz

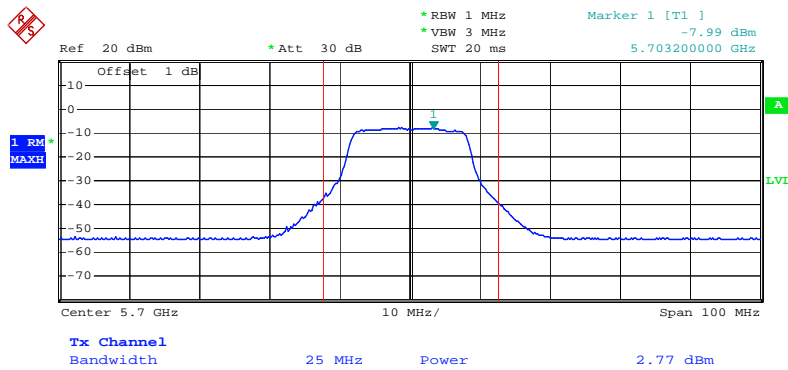

Date: 17.JUL.2009 16:29:32