

Emissions Test Report

EUT Name: Form 12S REX Meter

EUT Model: ZC599A00000 See page 73 for Variable model numbers

FCC Title 47, Part 15, SubpartC, RSS-210 Issue 6

Prepared for:

Bob Mason
Elster Electricity, LLC
208 South Rogers Lane
Raleigh, NC 27610
Tel: 919 212-4700
Fax: 919 212-5108

Prepared by:

TUV Rheinland of North America
762 Park Avenue
Youngsville, NC 27596
Tel: (919) 554-0901
Fax: (919) 556-2043
<http://www.tuv.com/>

Report/Issue Date: 13 December 2006

Report Number: 30662118.001

Statement of Compliance

Manufacturer: Elster Electricity, LLC
208 South Rogers Lane
Raleigh, NC 27610
919 212-4700
Requester / Applicant: Bob Mason
Name of Equipment: Form 12S REX Meter
Model No. ZC599A00000
Type of Equipment: Intentional Radiator
Application of Regulations: FCC Title 47, Part 15, SubpartC, RSS-210 Issue 6
Test Dates: 15 August 2006 to 28 August 2006

Guidance Documents:

Emissions: FCC 47 CFR Part 15, RSS-210 Issue 6



Test Methods:

Emissions: ANSI C63.4:2003

The electromagnetic compatibility test and documented data described in this report has been performed and recorded by TUV Rheinland of North America, in accordance with the standards and procedures listed herein. As the responsible authorized agent of the EMC laboratory, I hereby declare that a sample of one, of the equipment described above, has been shown to be compliant with the EMC requirements of the stated regulations and standards based on these results. If any special accessories and/or modifications were required for compliance, they are listed in the Executive Summary of this report.

This report must not be used to claim product endorsement by NVLAP or any agency of the U.S. Government. This report contains data that are not covered by NVLAP accreditation. This report shall not be reproduced except in full, without the written authorization of the laboratory.

	5 January 2007		5 January 2007
_____	Date	_____	Date
Test Engineer		NVLAP Signatory	

		Industry Canada
200094-0	90552 and 100881	IC3755

200094-0

Table of Contents

1	EXECUTIVE SUMMARY	4
1.1	SCOPE	4
1.2	PURPOSE	4
1.3	SUMMARY OF TEST RESULTS	4
1.4	SPECIAL ACCESSORIES	5
1.5	EQUIPMENT MODIFICATIONS	5
2	LABORATORY INFORMATION	5
2.1	ACCREDITATIONS & ENDORSEMENTS	5
2.2	TEST FACILITIES	6
2.3	MEASUREMENT UNCERTAINTY	7
2.4	CALIBRATION TRACEABILITY	7
3	PRODUCT INFORMATION	8
3.1	PRODUCT DESCRIPTION	8
3.2	EQUIPMENT CONFIGURATION	9
3.3	OPERATION MODE	9
4	EMISSIONS	10
4.1	CHANNEL SEPARATION PART 15.247(A)(1)	10
4.2	PSEUDORANDOM HOPPING ALGORITHM FCC PART 15.247(A)(1)	11
4.3	TIME OF OCCUPANCY FCC PART 15.247(A)(1)(I)	13
4.4	OCCUPIED BANDWIDTH FCC PART 15.247(A)(1)(I)	16
4.5	PEAK OUTPUT POWER FCC PART 15.247(B)(2)	19
5	EMISSIONS	21
5.1	RADIATED EMISSIONS	21
5.2	SPURIOUS EMISSIONS FCC PART 15.247(C)	25
5.3	FREQUENCY HOPPING SPREAD SPECTRUM SYSTEMS FCC PART 15.247(G)	35
5.4	INCORPORATION OF INTELLIGENCE WITHIN A FREQUENCY HOPPING SPREAD SPECTRUM SYSTEM FCC PART 15.247(H)	35
5.5	FREQUENCY STABILITY FCC PART 15.215(C)	35
5.6	CONDUCTED EMISSIONS	43
6	TEST EQUIPMENT USE LIST	54
7	EMC TEST PLAN	54
7.1	INTRODUCTION	54
	TECHNICAL DESCRIPTION	55
	CONFIGURATION(S)	61
	OPERATING CONDITIONS	64
	PERFORMANCE CRITERIA (REQUIRED FOR IMMUNITY TESTING ONLY)	71
	POWER REQUIREMENTS	72
	OSCILLATOR / MICROPROCESSOR FREQUENCIES	72
	EQUIVALENT MODELS	73
	METHODS OF DETERMINING EQUIVALENCE	73

1 Executive Summary

1.1 Scope

This report is intended to document the status of conformance with the requirements of the FCC Title 47, Part 15, SubpartC, RSS-210 Issue 6 based on the results of testing performed on 15 August 2006 through 28 August 2006 on the *Form 12S REX Meter* Model No. ZC599A00000 manufactured by Elster Electricity, LLC. This report only applies to the specific samples tested under the stated test conditions. It is the responsibility of the manufacturer to assure that additional production units of this model are manufactured with identical or EMI equivalent electrical and mechanical components. This report is further intended to document changes and modifications to the EUT throughout its life cycle. All documentation will be included as a supplement.

1.2 Purpose

Testing was performed to evaluate the EMC performance of the EUT in accordance with the applicable requirements, procedures, and criteria defined in the application of regulations and application of standards listed in this report.

1.3 Summary of Test Results

Table 1 - Summary of Test Results

Test	Test Method(s)	Test Parameters	Measurement	Result
Channel Separation	FCC Part 15.247(a)(1)	Greater of 25 kHz or 20 dB bandwidth	401.25 kHz	compliant
Pseudorandom Hopping Algorithm				compliant
Time of Occupancy	FCC Part 15.247(a)(1)(i)	=<0.4 sec in 10 sec.	0.396 sec in 10sec	compliant
Occupied Bandwidth	FCC Part 15.247(a)(1)(i)	=<500kHz	395 kHz	compliant
Peak Output Power	FCC Part 15.247(b)(2)	0.25 Watts	0.236 Watts	compliant
Spurious Emissions	FCC Part 15.247(C)	Table FCC Part 15.209	41.03 dBuV/m @ 3meters Average	compliant
Frequency Hopping Spread Spectrum Systems	FCC Part 15.247(g)			compliant
Incorporation of Intelligence	FCC Part 15.247(h)			compliant
Frequency Stability	FCC Part 15.215(c)	Containment of 20 dB bandwidth between 902 and 928	902.594 MHz 927.870 MHz	compliant
Conducted Emissions	47 CFR Part 15.207, ANSI C63.4:1992, RSS-210 Issue 5	Table FCC Part 15.207	45.18 dBuV Average	compliant

1.4 Special Accessories

No special accessories were necessary in order to achieve compliance.

1.5 Equipment Modifications

No modifications were found to be necessary in order to achieve compliance.

2 Laboratory Information

2.1 Accreditations & Endorsements

2.1.1 US Federal Communications Commission

TUV Rheinland of North America at the 762 Park Ave. Youngsville, N.C 27596 address is accredited by the commission for performing testing services for the general public on a fee basis. This laboratory test facilities have been fully described in reports submitted to and accepted by the FCC (Registration No 90552 and 100881). The laboratory scope of accreditation includes: Title 47 CFR Part 15, 18, and 90. The accreditation is updated every 3 years.

2.1.2 NIST / NVLAP

TUV Rheinland of North America is accredited by the National Voluntary Laboratory Accreditation Program, which is administered under the auspices of the National Institute of Standards and Technology. The laboratory has been assessed and accredited in accordance with ISO Guide 25 and ISO 9002 (Lab code 200094-0). The scope of laboratory accreditation includes emission and immunity testing. The accreditation is updated annually.

2.1.3 Canada – Industry Canada

Registration No. IC3755

2.1.4 Japan - VCCI

The Voluntary Control Council for Interference by Information Technology Equipment (VCCI) is a group that consists of Information Technology Equipment (ITE) manufacturers and EMC test laboratories. The purpose of the Council is to take voluntary control measures against electromagnetic interference from Information Technology Equipment, and thereby contribute to the development of a socially beneficial and responsible state of affairs in the realm of Information Technology Equipment in Japan. TUV Rheinland of North America at the 762 Park Ave. Youngsville, N.C 27596 address has been assessed and approved in accordance with the Regulations for Voluntary Control Measures. (Registration No. R-1174 and C-1236).

2.1.5 Acceptance By Mutual Recognition Arrangement

The United States has an established agreement with specific countries under the Asia Pacific Laboratory Accreditation Corporation (APLAC) Mutual Recognition Arrangement. Under this agreement, all TUV Rheinland of North America at the 762 Park Ave. Youngsville, N.C 27596 address test results and test reports within the scope of the laboratory NIST / NVLAP accreditation will be accepted by each member country.

2.2 Test Facilities

All of the test facilities are located at 762 Park Ave., Youngsville, North Carolina 27596, USA.

2.2.1 Emission Test Facility

The Open Area Test Site and AC Line Conducted measurement facility used to collect the radiated and conducted data has been constructed in accordance with ANSI C63.7:1992. The site has been measured in accordance with and verified to comply with the theoretical normalized site attenuation requirements of ANSI C63.4:2003, at a test distance of 3 and 10 meters. This site has been described in reports dated May 12, 1997, submitted to the FCC, and accepted by letter dated June 25, 1997 (31040/SIT 1300F2). The site is listed with the FCC and accredited by NVLAP (code 200094-0). The 5m semi-anechoic chamber used to collect the radiated data has been verified to comply with the theoretical normalized site attenuation requirements of ANSI C63.4:2005, at a test distance of 3 meters. A report detailing this site can be obtained from TUV Rheinland of North America.

2.2.2 Immunity Test Facility

ESD, EFT, Surge, PQF: These tests are performed in an environmentally controlled room with a 3.7m x 3.7m x 3.175mm thick aluminum floor connected to PE ground. For ESD testing, tabletop equipment is placed on an insulated mat with a surface resistivity of 10^9 Ohms/square on a 1.6m x 0.8m x 0.8m high non-conductive table with a 3.175mm aluminum top (Horizontal Coupling Plane). The HCP is connected to the main ground plane via a low impedance ground strap through two 470 k Ω resistors. The Vertical Coupling Plane consists of an aluminum plate 50cm x 50cm x 3.175mm thick. The VCP is connected to the main ground plane via a low impedance ground strap through two 470 k Ω resistors. For each of the other tests, the HCP is removed.

RF Field Immunity testing is performed in a 7.3m x 3.7m x 3.2m anechoic chamber.

RF Conducted and Magnetic Field Immunity testing is performed on a 4.9m x 3.7m x 3.175mm thick aluminum ground plane which is connected to one end of the anechoic chamber.

All test areas allow a minimum distance of 1 meter from the EUT to walls or conducting objects.

2.3 Measurement Uncertainty

Two types of measurement uncertainty are expressed in this report, per *ISO Guide To The Expression Of Uncertainty In Measurement*, 1st addition, 1995.

The Combined Standard Uncertainty is the standard uncertainty of the result of a measurement when that result is obtained from the values of a number of other quantities, equal to the positive square root of a sum of terms, the terms being the variances or co-variances of these other quantities weighted according to how the measurement result varies with changes in these quantities. The term standard uncertainty is the result of a measurement expressed as a standard deviation.

The Expanded Uncertainty defines an interval about the result of a measurement that may be expected to encompass a large fraction of the distribution of values that could reasonably be attributed to the measurand. The fraction may be viewed as the coverage probability or level of confidence of the interval.

The test system for conducted emissions is defined as the LISN, spectrum analyzer, coaxial cables, and pads. The test system for radiated emissions is defined as the antenna, spectrum analyzer, pre-amplifier, coaxial cables, and pads. The conducted test system has a combined standard uncertainty of ± 1.2 dB. The radiated test system has a combined standard uncertainty of ± 1.6 dB. The expanded uncertainty at a level of 95% confidence is obtained by multiplying the combined standard uncertainty by a coverage factor of 2. Compliance criteria are not based on measurement uncertainty.

2.4 Calibration Traceability

All measurement instrumentation is traceable to the National Institute of Standards and Technology (NIST). Measurement method complies with ANSI/NCSL Z540-1-1994 and ISO Guide 25.

3 Product Information



Figure 1 – Photo of EUT

3.1 Product Description

The information for all equipment used in the tested system, including: descriptions of cables, clock and microprocessor frequencies, EMI critical components, and accessory equipment has been supplied by the manufacturer and is listed in the EMC Test Plan found in Section 7.

3.2 Equipment Configuration

A description and justification of the equipment configuration is given in the EMC Test Plan. The EUT was tested as described in the EMC Test Plan and was configured and operated in a manner consistent with its intended use. The EUT was connected to rated power and allowed to warm up to normal operating conditions. The placement of the EUT system components was guided by the test standard and selected to represent typical installation conditions.

In the case of an EUT that can operate in more than one configuration, preliminary testing was performed to determine the configuration that produced maximum radiation.

The final configuration was selected to produce worse case radiation and place the EUT in the most susceptible state. There were no deviations from the description of the Equipment Configuration given in the EMC Test Plan.

Four meters were presented for testing as follows:

R1S – 240VAC 60Hz

R1S – 120VAC 60Hz

R1SD – 240VAC 60Hz

R1SD - 120VAC 60Hz

The meters with the “D” designator have an additional an Internal Service Disconnect Switch. The electronics and Radio device remain the same across all meters. Radiated and Spurious Emissions measurement were taken on all four meters to identify a “Worst Case” scenario, and then the remaining test were performed on that one “Worst Case” meter. There was virtually little difference between any of the four meters tested preliminarily.

3.3 Operation Mode

A description and justification of the operation mode is given in the EMC Test Plan.

In the case of an EUT that can operate in more than one state, preliminary testing was performed to determine the operating mode that produced maximum radiation.

The final operating mode was selected to produce worse case radiation and place the EUT in the most susceptible state. There were no deviations from the description of the Operation Mode given in the EMC Test Plan.

4 Emissions

Testing was performed in accordance with 47 CFR Part 15, ANSI C63.4:1992, RSS-210 Issue 5. These test methods are listed under the laboratory's NVLAP Scope of Accreditation. This test measures the levels emanating from the EUT, thus evaluating the potential for the EUT to cause radio frequency interference to other electronic devices.

4.1 Channel Separation Part 15.247(a)(1)

Frequency hopping Systems shall have hopping channel carrier frequencies separated by a minimum of 25 kHz or the 20 dB bandwidth of the hopping channel, whichever is greater.

Bandwidth=395 kHz

Channel Separation=401.25 kHz

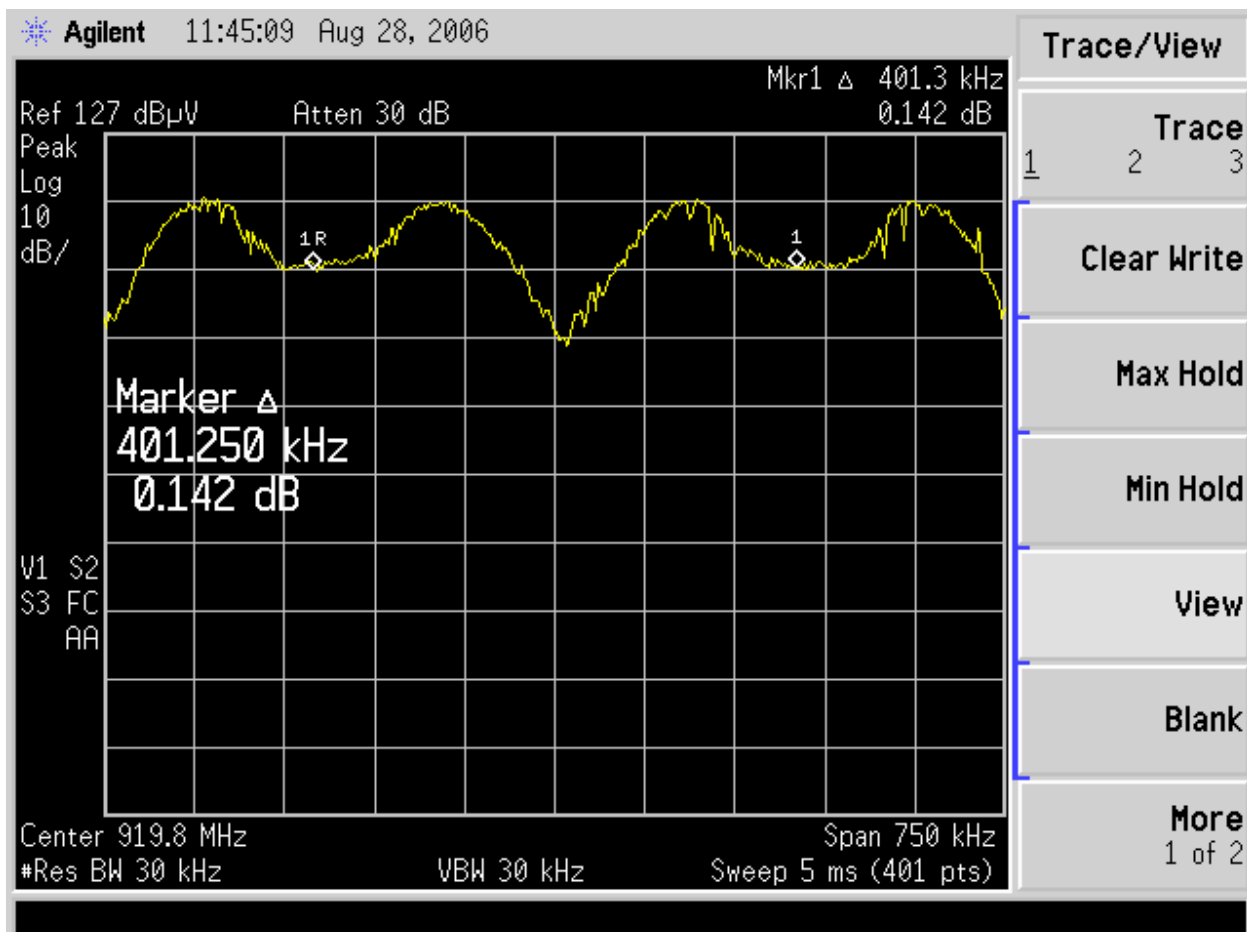

4.2 Pseudorandom Hopping Algorithm FCC Part 15.247(a)(1)

The system shall hop to channel frequencies that are selected from a pseudorandomly ordered list of hopping frequencies. Each frequency must be used equally on average by each transmitter. The system receivers shall have input bandwidths that match the hopping channel bandwidths of their transmitters and shall shift frequencies in synchronization with the transmitted signals.

The pseudo-random hop table is used to determine the transmitter's frequency hop sequence. The transmitter is slow hopping frequency system where the entire data packet is sent on a single channel. After sending a data packet, the transmitter uses the next channel in the pseudo-random hop table. Each frequency in the hop table is used before the transmitter will hop to a frequency already used. The receiver is a single IF system whose bandwidth is 330 kHz. When not synchronized to a transmitting device, the receiver is constantly hopping across the 25 channels scanning for a valid preamble from a transmitter. Once a valid preamble is detected, the receiver is synchronized to the transmitter and receives the data packet. After the transmission, the receiver returns to the scanning mode where it can look for another packet from either the same device or a different device.

Index	Channel	Network #1 "Low Band" Center Frequency (MHz)	Network #2 "High Band" Center Frequency (MHz)
1	12	907.2	920.0
2	29	914.0	926.8
3	5	904.4	917.2
4	19	910.0	922.8
5	11	906.8	919.6
6	23	911.6	924.4
7	26	912.8	925.6
8	13	907.6	920.4
9	22	911.2	924.0
10	15	908.4	921.2
11	1	902.8	915.6
12	25	912.4	925.2
13	4	904.0	916.8
14	21	910.8	923.6
15	14	908.0	920.8
16	27	913.2	926.0
17	8	905.6	918.4
18	31	914.8	927.6
19	18	909.6	922.4
20	16	908.8	921.6
21	7	905.2	918.0
22	20	910.4	923.2

Index	Channel	Network #1 "Low Band" Center Frequency (MHz)	Network #2 "High Band" Center Frequency (MHz)
23	3	903.6	916.4
24	28	913.6	926.4
25	6	904.8	917.6

Sample hop table

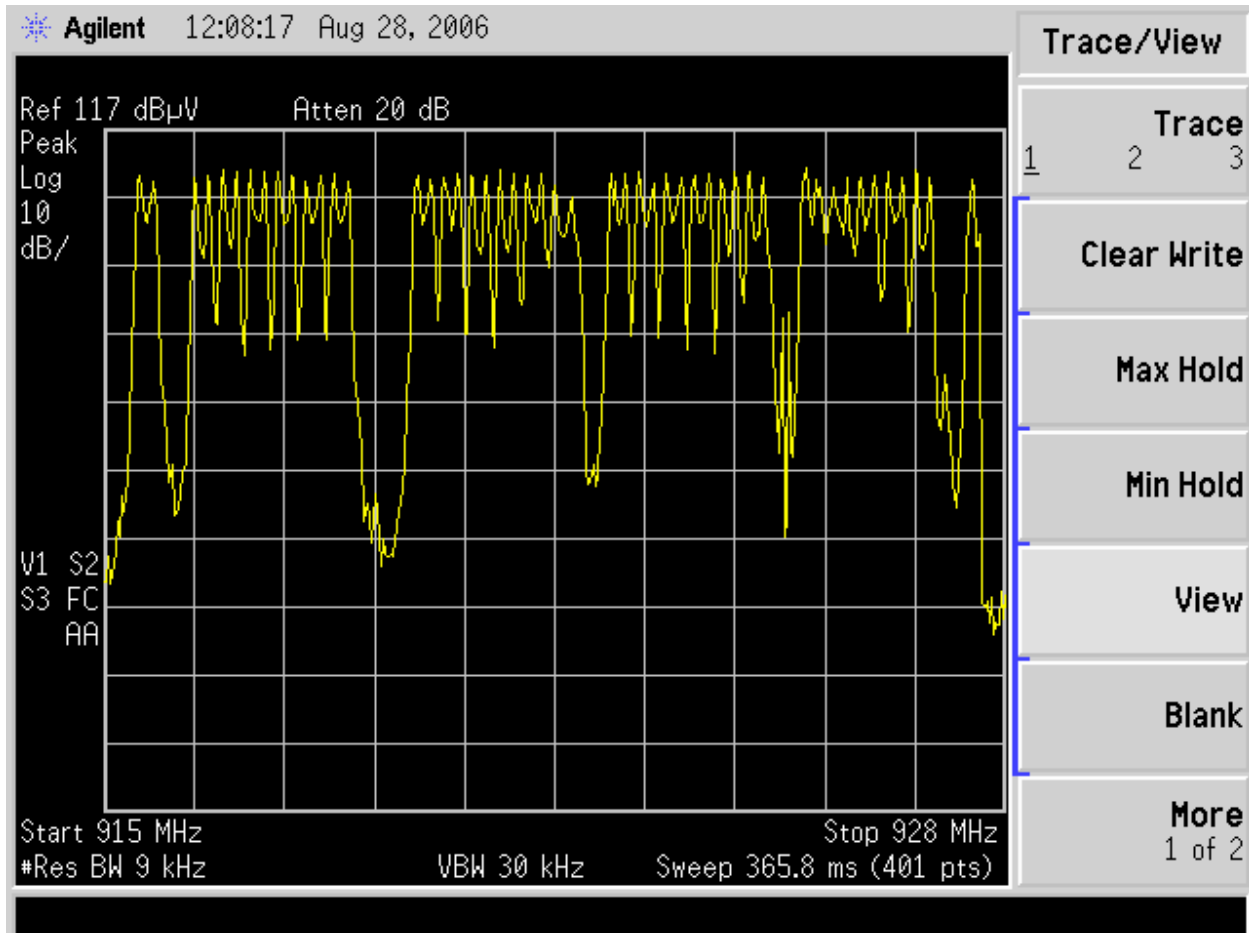

Figure 2 - Plot of hopping Channels

4.3 Time of Occupancy FCC Part 15.247(a)(1)(i)

Frequency Band (MHz)	20 dB Bandwidth	Number of Hopping Channels	Average Time of Occupancy
902-928	=>250 kHz	25	=<0.4 sec. In 10 sec.

The spectrum analyzer was set as follows:

RBW=9 kHz

VBW=RBW

Span=0Hz

LOG dB/div.= 10dB

Sweep = 10 Sec.

Trigger Video

The occupancy time was measured as above. There were 4 hops at .0975 seconds per hop for any 10 sec. Period. Time of occupancy equals number of hops multiplied by the duration of one hop.

Time of Occupancy = 0.390 seconds in any 10 second period.

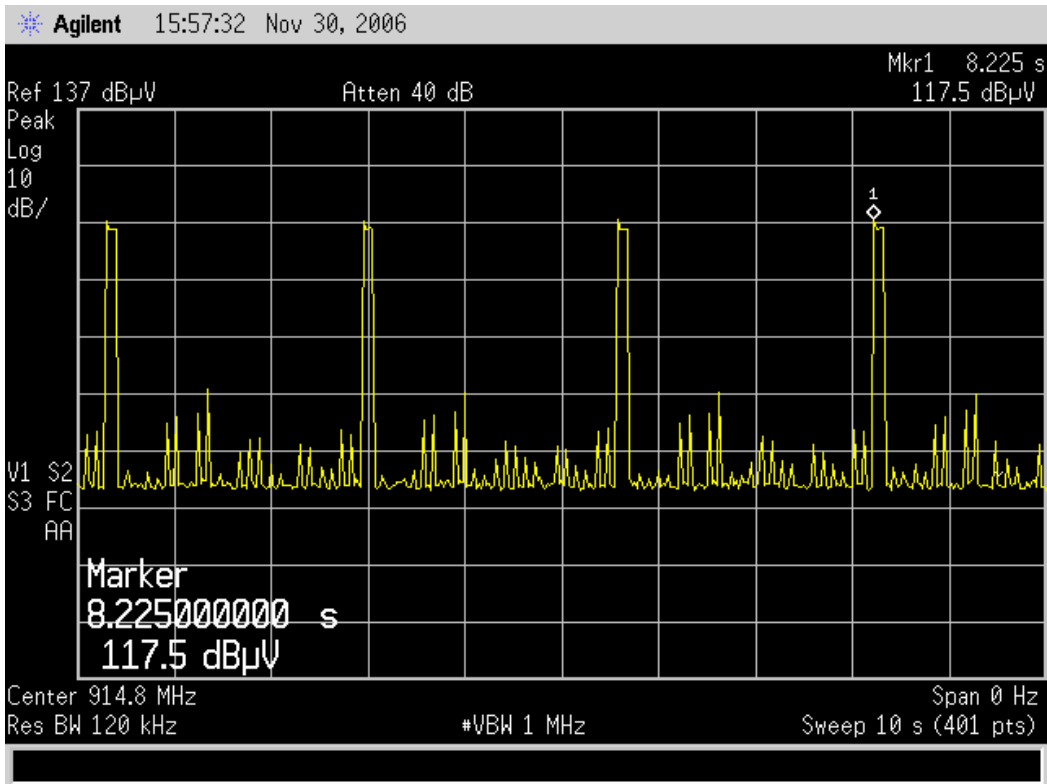

Figure 3 – 10 second sweep “Low Band” of 914.8 MHz

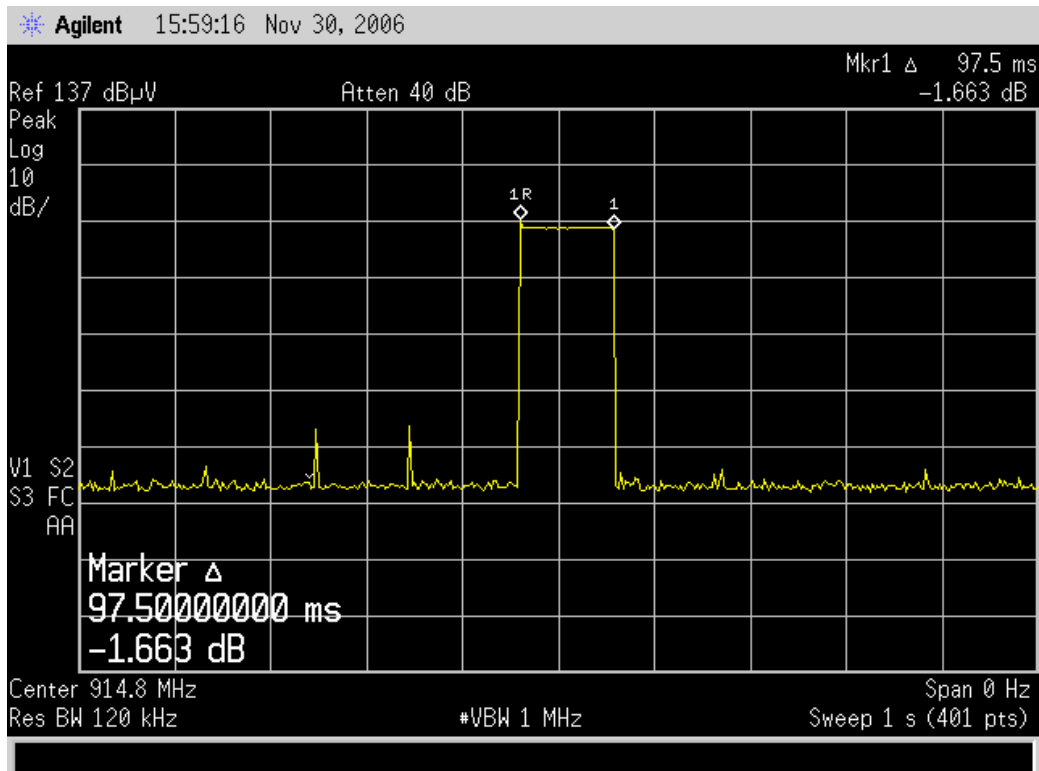

Figure 4 – Measurement of 1 hop in “Low Band” 914.8 MHz

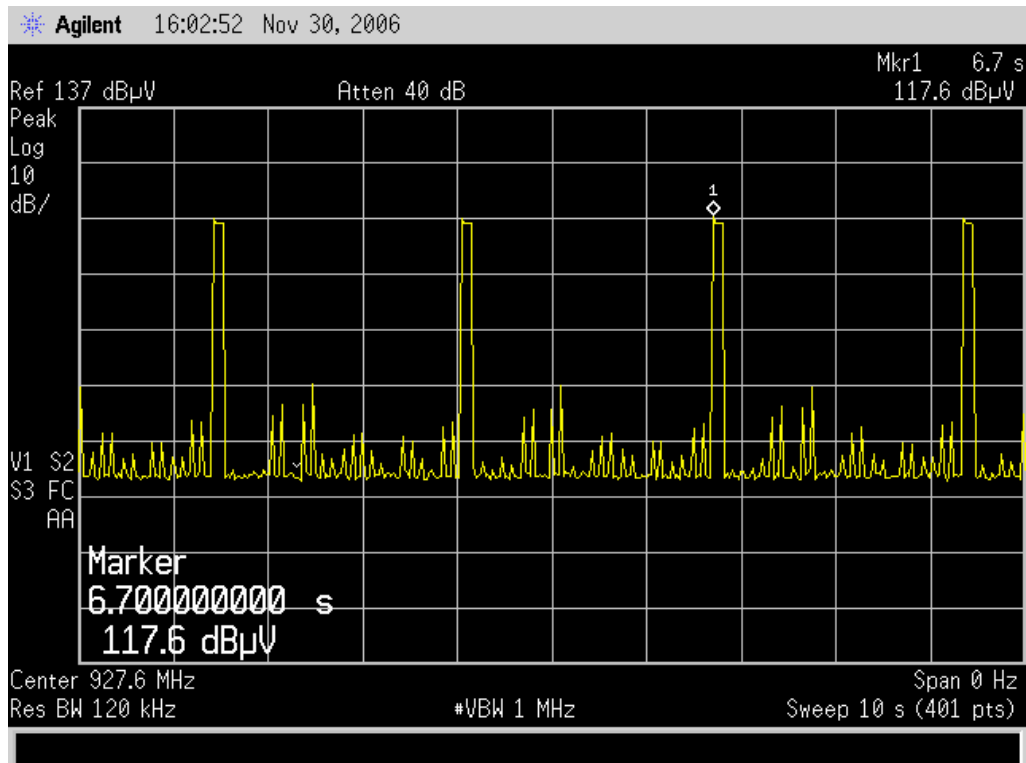

Figure 5 – 10 Second sweep of “High Band” 926 MHz

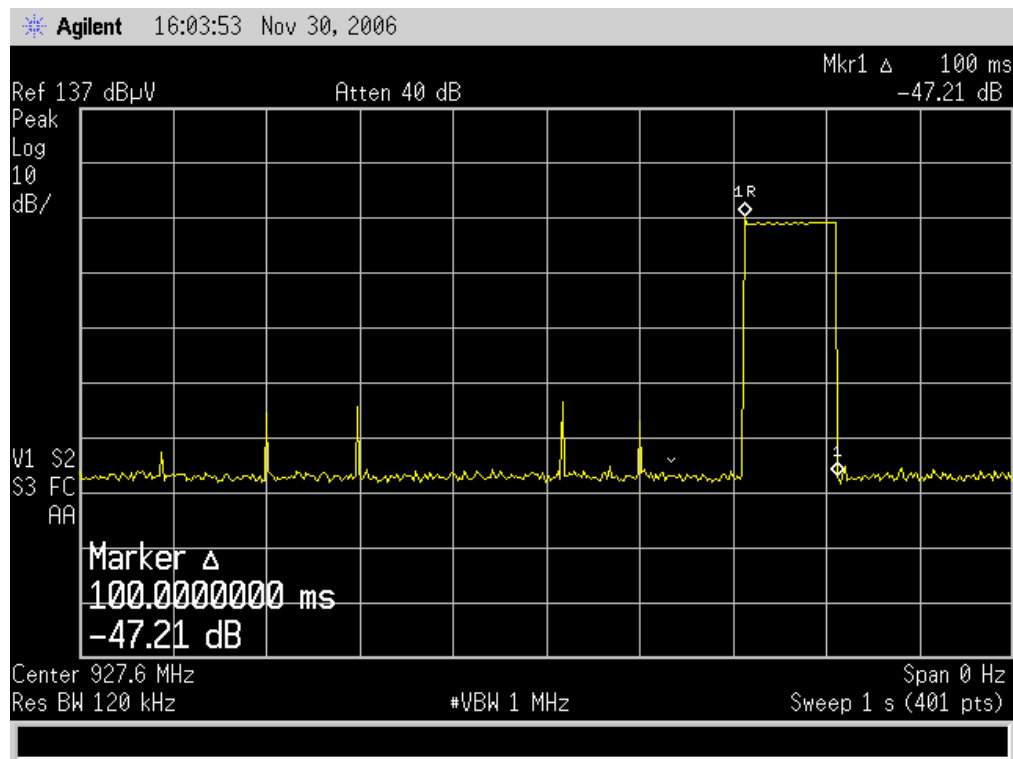

Figure 6 – Measurement of 1 hop in “High Band” 927.6 MHz

4.4 Occupied Bandwidth FCC Part 15.247(a)(1)(i)

The maximum allowed 20 dB bandwidth of the hopping channel is 500 kHz.

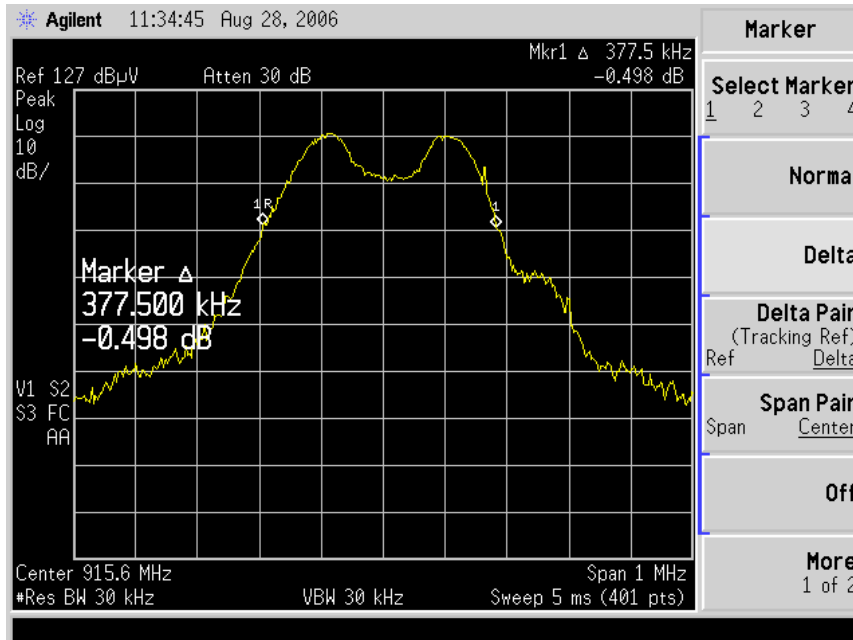

Figure 7 – CH1 “High Band” 915.6 MHz Occupied Bandwidth

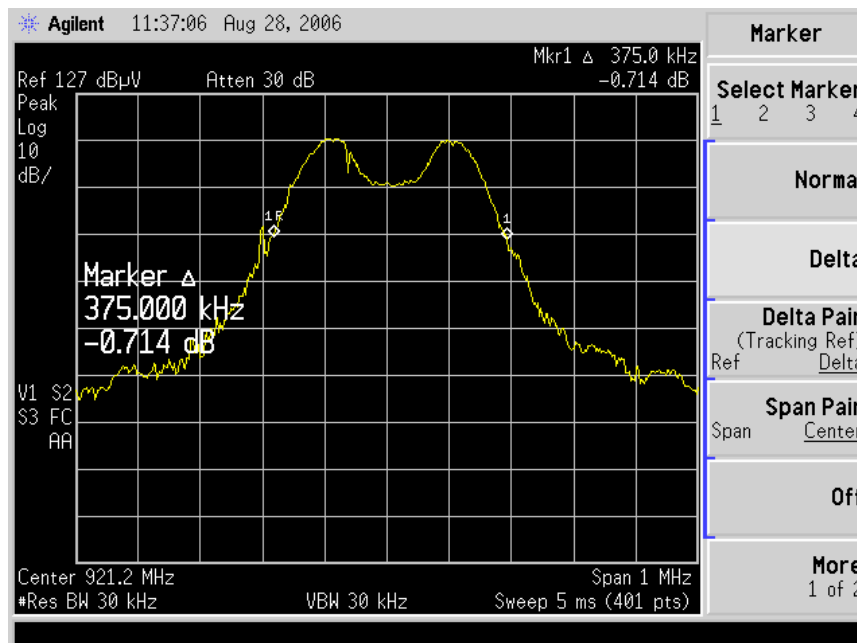

Figure 8 – CH15 “High Band” 921.2 MHz Occupied Bandwidth

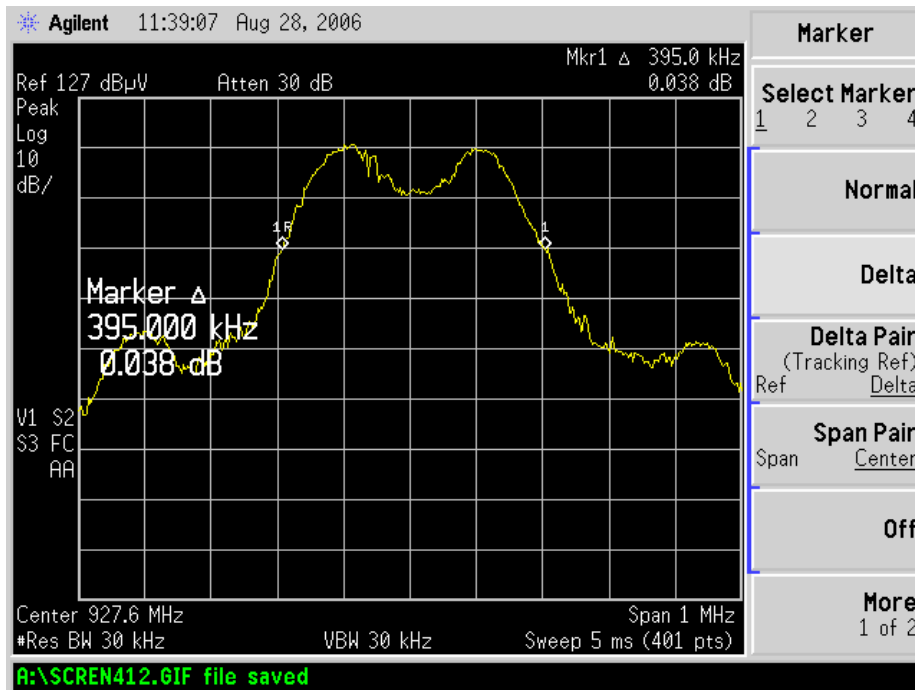

Figure 9 – CH31 “High Band” 927.6 MHz Occupied Bandwidth

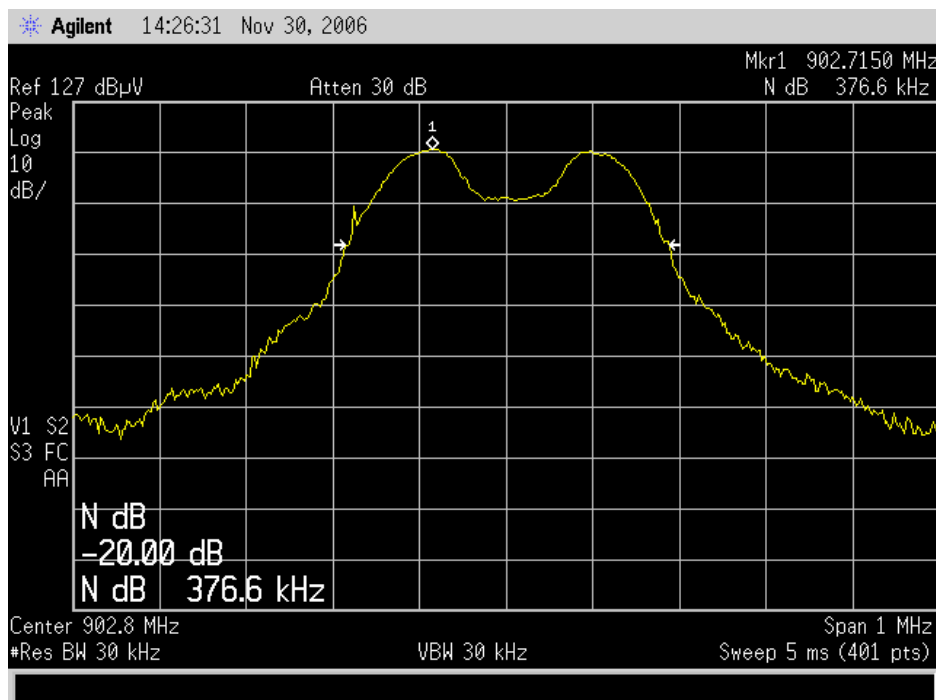

Figure 10 – CH 1 “Low Band” 902.8 MHz

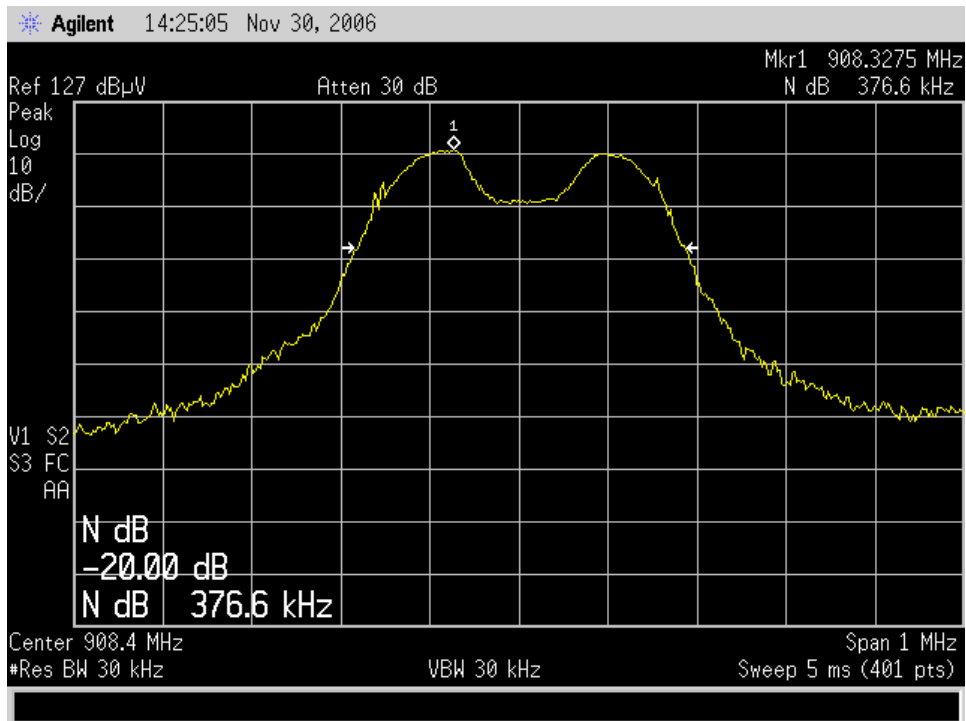

Figure 11 – CH 15 “Low Band” 908.4 MHz

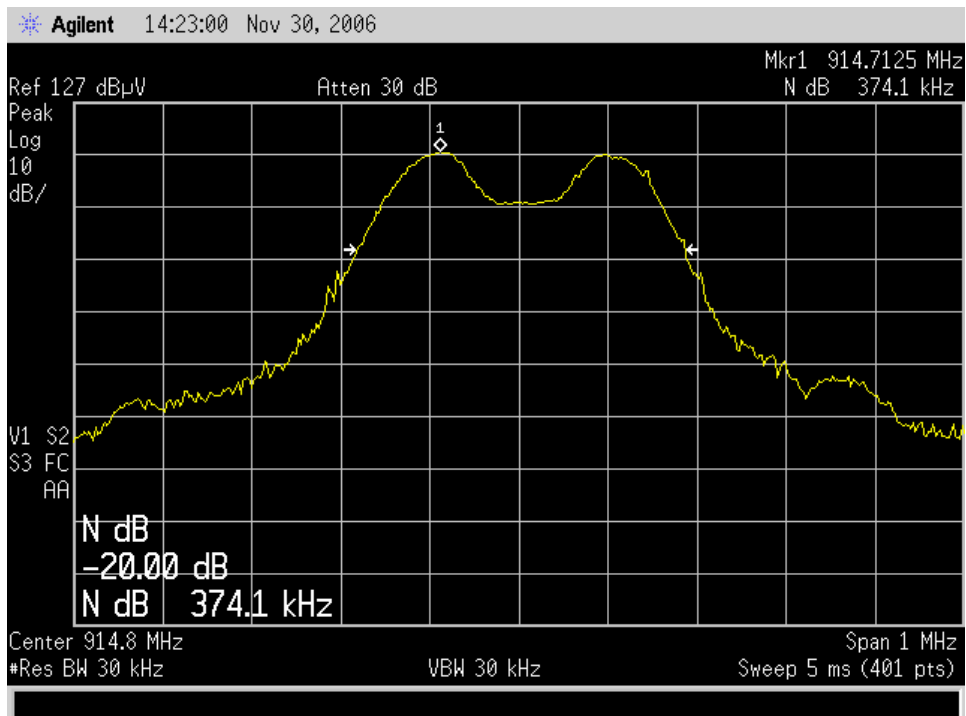

Figure 12 – CH 31 “Low Band” 914.8 MHz

4.5 Peak Output Power FCC Part 15.247(b)(2)

The maximum peak output power of the intentional radiator shall not exceed 0.25 watts for systems employing less than 50 hopping channels, but at least 25 hopping channels. (Conducted Measurement)

The peak output power was measured at CH1, CH15, and at CH31. The measurement was made using a direct connection between the RF output of the EUT and the spectrum analyzer. After the measurement was made the cable loss and the attenuator was added to the measurement. The spectrum analyzer's resolution bandwidth was greater than the 20dB bandwidth of the modulated carrier and the video bandwidth was equal to the resolution bandwidth.

Test Setup



Peak Power Output	Low Band
	CH1 - 902.8 MHz = 0.230 Watts
	CH15 - 908.4 MHz = 0.230 Watts
	CH31 - 914.8 MHz = 0.236 Watts
	High Band
	CH1 - 915.6 MHz = 0.236 Watts
	CH15 - 921.2 MHz = 0.229 Watts
	CH31 - 927.6 MHz = 0.228 Watts

Antenna Gain

If peak power output was performed using the conducted method then the antenna gain will be stated.

The Substitution method was used.

The measurement was performed with out modulation. The transmitter under test was placed on a non-conductive table 80cm above the ground plane. The spectrum analyzer was tuned to the transmitter carrier frequency and the turntable was rotated 360 degrees about the vertical axis until the highest maximum signal was received. Then the receive antenna was raised and lowered 1 to 4 meters until the maximum signal was detected. Then the substitution dipole antenna and signal generator replaced the transmitter under test and both the receive and substitution dipole antenna were placed in the vertical polarization. The input signal to the substitution antenna was adjusted to the maximum signal received from the transmitter. The receive antenna was then raised and lowered to ensure the maximum signal was still received. The cable to the dipole was then removed and attached to a calibrated power meter to record the power level and added to the substitution dipole gain to obtain the EIRP level. Then the steps above were repeated for the horizontal polarization. The gain of the EUT antenna is the difference between the measured RF power at the RF port and the measured EIRP.

4.5.1.1 Results

Frequency	Polarization	Conducted Power Measurement	Measured EIRP	Antenna Gain
902.8 MHz	Vertical	23.89 dBm	29.49 dBm	5.6 dBi
902.8 MHz	Horizontal	23.89 dBm	23.30 dBm	-0.59 dBi
908.4 MHz	Vertical	23.86 dBm	29.46 dBm	5.6 dBi
908.4 MHz	Horizontal	23.86 dBm	23.61 dBm	-0.25 dBi
914.8MHz	Vertical	23.65 dBm	29.52 dBm	5.87 dBi
914.8 MHz	Horizontal	23.65 dBm	23.95 dBm	0.3 dBi

5 Emissions

5.1 Radiated Emissions

Testing was performed in accordance with 47 CFR 15, ANSI C63.4:1994. These test methods are listed under the laboratory's NVLAP Scope of Accreditation. This test measures the levels emanating from the EUT, thus evaluating the potential for the EUT to cause radio frequency interference to other electronic devices.

5.1.1 Test Methodology

5.1.1.1 Preliminary Test

A test program that controls instrumentation and data logging was used to automate the preliminary RF emission test procedure. The frequency range of interest was divided into sub-ranges to yield a frequency resolution of approximately 300 kHz and provide a reading at each frequency for each 6° of turntable rotation. For each frequency sub-range the turntable was rotated 360° while peak emission data was recorded and plotted over the frequency range of interest in horizontal and vertical antenna polarization's.

Preliminary emission profile testing was performed inside the anechoic chamber. The EUT was placed on a 1.0m x 1.5m non-conductive table 80cm above the floor. The EUT was positioned as shown in the setup photographs. The receiving antenna was placed at a distance of 3m at a fixed height of 1m. Measurement equipment was located outside of the chamber. A video camera was placed inside the chamber to view the EUT.

5.1.1.2 Final Test

For each frequency measured, the peak emission was maximized by manipulating the receiving antenna from 1 to 4 meters above the ground plane and placing it at the position that produced the maximum signal strength reading. The turntable was then rotated through 360° while observing the peak signal and placing the EUT at the position that produced maximum radiation. The six highest emissions relative to the limit were measured unless such emissions were more than 20 dB below the limit. If less than six emissions are within 20 dB of the limit, than the noise level of the receiver is measured at frequencies where emissions are expected. Multiples of all oscillator and microprocessor frequencies were also checked.

Final testing was performed on an NSA compliant test site. The EUT was placed on a 1.0m x 1.5m non-conductive table 80cm above the ground plane. The placement of EUT and cables were the same as for preliminary testing and is shown in the setup photographs.

5.1.1.3 Deviations

There were no deviations from this test methodology.

5.1.2 Test Results

Section 5.1.2.1 lists the final measurement data under the worst case operating modes, configurations, and/or cable positions. It also reflects the results including any modifications and/or special accessories listed in Sections 1.4 and 1.5.

As originally tested, the EUT was found to be compliant to the requirements of the test standard(s).

5.1.2.1 Final Data

The data recorded in this section contains the final results under the worst-case conditions and with any modifications or special accessories implemented as the manufacturer intends.

SOP 1 Radiated Emissions

Tracking # 30662118.001 Page 1 of 2

EUT Name	Form 12S REX Meter	Date	21 August 2006
EUT Model	ZC599A00000	Temp / Hum in	70 Deg F / 67%rh
EUT Serial	06210289	Temp / Hum out	N/A
Standard	FCC 47 CFR Part 15, RSS-210 Issue 6	Line AC / Freq.	120VAC 60Hz
Deg/sweep	12 degrees	RBW / VBW	120KHz/300KHz
Dist/Ant Used	3 meters/CBL6140A	Performed by	Randy Masline
Configuration	Not transmitting		

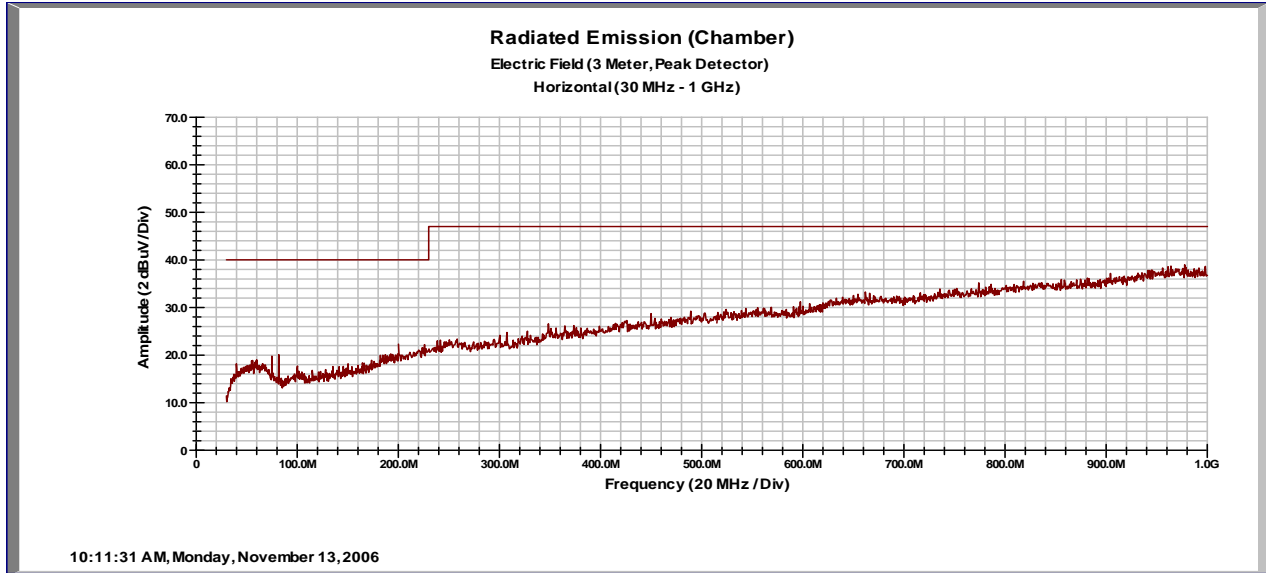

Emission Freq (MHz)	ANT Polar (H/V)	ANT Pos (m)	Table Pos (deg)	FIM Value (dBuV)	Amp Gain (dB)	Cable Loss (dB)	ANT Factor (dB/m)	E-Field Value (dBuV/m)	Spec Limit (dBuV/m)	Spec Margin (dB)

Spec Margin = E-Field Value - Limit, E-Field Value = FIM Value - Amp Gain + Cable Loss + ANT Factor ± Uncertainty
 Combined Standard Uncertainty $u_c(y) = \pm 1.6\text{dB}$ Expanded Uncertainty $U = ku_c(y)$ $k = 2$ for 95% confidence

Notes:

SOP 1 Radiated Emissions

Tracking # 30662118.001 Page 2 of 2

EUT Name	Form 12S REX Meter	Date	21 August 2006
EUT Model	ZC599A00000	Temp / Hum in	70 Deg F / 67%rh
EUT Serial	06210289	Temp / Hum out	N/A
Standard	FCC 47 CFR Part 15, RSS-210 Issue 6	Line AC / Freq.	120VAC 60Hz
Deg/sweep	12 degrees	RBW / VBW	120KHz/300KHz
Dist/Ant Used	3 Meters/CBL6140A	Performed by	Randy Masline
Configuration	Not Transmitting		

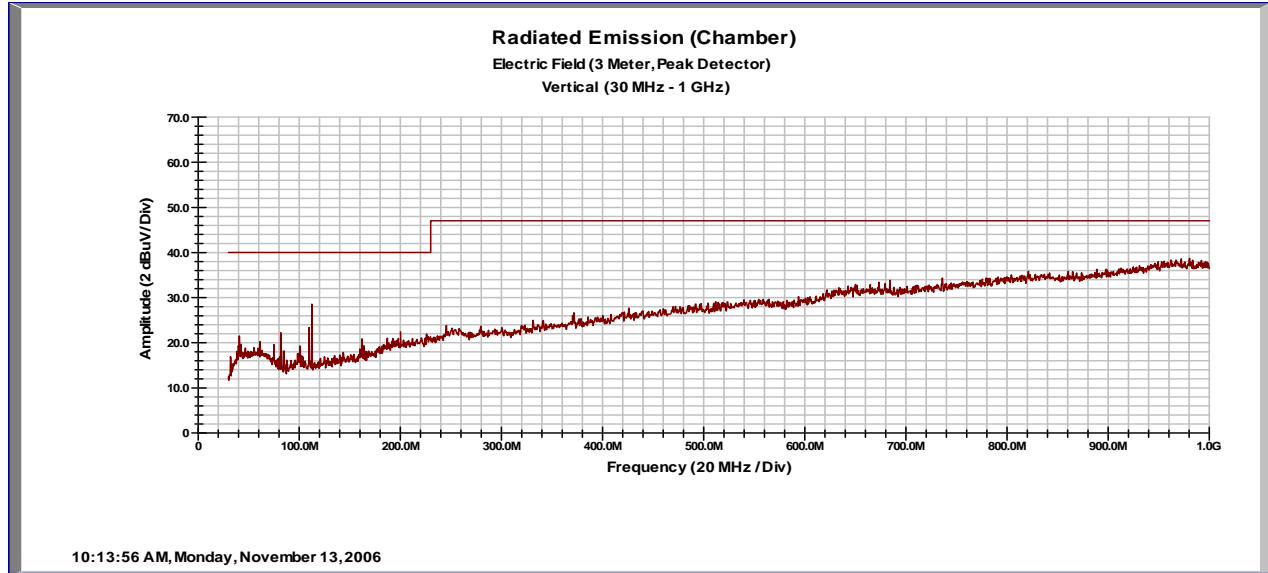

Emission Freq (MHz)	ANT Polar (H/V)	ANT Pos (m)	Table Pos (deg)	FIM Value (dBuV)	Amp Gain (dB)	Cable Loss (dB)	ANT Factor (dB/m)	E-Field Value (dBuV/m)	Spec Limit (dBuV/m)	Spec Margin (dB)
40.44	V	1	0	16.26	0.00	0.69	8.64	25.59	40.00	-14.41
61.16	V	1	0	16.69	0.00	0.84	9.25	26.78	40.00	-13.22
75.12	V	1	0	18.41	0.00	0.93	7.49	26.82	40.00	-13.18
81.50	V	1	0	16.48	0.00	0.98	6.90	24.36	40.00	-15.64
110.48	V	1	0	17.10	0.00	1.14	7.31	25.55	40.00	-14.45
112.32	V	1	0	17.10	0.00	1.15	7.35	25.59	40.00	-14.41

Spec Margin = E-Field Value - Limit, E-Field Value = FIM Value - Amp Gain + Cable Loss + ANT Factor ± Uncertainty

Combined Standard Uncertainty $u_c(y) = \pm 1.6\text{dB}$ Expanded Uncertainty $U = ku_c(y)$ $k = 2$ for 95% confidence

Notes:

5.2 Spurious Emissions FCC Part 15.247(c)

5.2.1 Test Methodology

5.2.1.1 Preliminary Test

A test program that controls instrumentation and data logging was used to automate the preliminary RF emission test procedure. The frequency range of interest was divided into sub-ranges to yield a frequency resolution of approximately 300 kHz and provide a reading at each frequency for each 6° of turntable rotation. For each frequency sub-range the turntable was rotated 360° while peak emission data was recorded and plotted over the frequency range of interest in horizontal and vertical antenna polarization's.

Preliminary emission profile testing was performed inside the anechoic chamber. The EUT was placed on a 1.0m x 1.5m non-conductive table 80cm above the floor. The EUT was positioned as shown in the setup photographs. The receiving antenna was placed at a distance of 3m at a fixed height of 1m. Measurement equipment was located outside of the chamber. A video camera was placed inside the chamber to view the EUT.

5.2.1.2 Final Test

For each frequency measured, the peak emission was maximized by manipulating the receiving antenna from 1 to 4 meters above the ground plane and placing it at the position that produced the maximum signal strength reading. The turntable was then rotated through 360° while observing the peak signal and placing the EUT at the position that produced maximum radiation.

Final testing was performed on an NSA compliant test site. The EUT was placed on a 1.0m x 1.5m non-conductive table 80cm above the ground plane. The placement of EUT and cables were the same as for preliminary testing and is shown in the setup photographs.

5.2.1.3 Deviations

There were no deviations from this test methodology.

5.2.2 Test Results

As originally tested, the EUT was found to be compliant to the requirements of the test standard(s).

5.2.2.1 Radiated Emissions Outside the Frequency Band

In any 100kHz bandwidth outside the frequency band in which the spread spectrum or digitally modulated intentional radiator is operating, the radio frequency power that is produced by the intentional radiator shall be at least 20 dB below that in the 100 kHz bandwidth within the band that contains the highest level of desired power, based on radiated measurements.

SOP 1 Radiated Emissions

Tracking # 30662118.001 Page 1 of 9

EUT Name	Form 12S REX Meter	Date	21 August 2006
EUT Model	ZC599A00000	Temp / Hum in	70 Deg F / 67%rh
EUT Serial	06210289	Temp / Hum out	N/A
Standard	FCC 47 CFR Part 15, RSS-210 Issue 6	Line AC / Freq.	120VAC 60Hz
Deg/sweep		RBW / VBW	100KHz/100KHz
Dist/Ant Used	3 meters 1Ghz -10GHz (3115-9903) 200MHz – 1GHz (SAS – 516)	Performed by	Randy Masline

Configuration Worst case Meter s/n 06210289

Emission Freq (MHz)	ANT Polar (H/V)	ANT Pos (m)	Table Pos (deg)	FIM Value (dBuV)	Amp Gain (dB)	Cable Loss (dB)	ANT Factor (dB/m)	E-Field Value (dBuV/m)	20dB below Fundamental (dBuV/m)
"Low Band"									
Channel 1									
902.80	H	1	75	83.53	0.00	2.80	23.40	109.73	N/A
1805.00	H	1	43	41.89	35.49	5.43	26.63	38.46	
902.80	V	1	43	91.94	0.00	2.80	22.26	117.00	N/A
1805.00	V	1	43	51.26	35.49	5.43	26.63	47.83	
"Low Band"									
Channel 31									
914.80	H	1.26	79	90.75	0.00	2.80	23.50	117.04	N/A
1829.00	H	1	48	39.90	35.43	5.45	26.73	36.65	87.04
914.80	V	1	36	93.72	0.00	2.80	22.59	119.11	N/A
1829.00	V	1	48	47.03	35.43	5.45	26.69	43.74	75.37
"High Band"									
Channel 31									
927.60	H	1	300	86.71	0.00	3.44	23.05	113.20	N/A
1855.20	H	1	0	35.59	0.00	4.95	31.71	72.25	40.95
927.60	V	1	0	93.42	0.00	3.44	22.80	119.66	N/A
1855.20	V	1	0	35.20	0.00	4.95	31.50	71.65	48.01

Spec Margin = E-Field Value - Limit, E-Field Value = FIM Value - Amp Gain + Cable Loss + ANT Factor ± Uncertainty

Combined Standard Uncertainty $u_c(y) = \pm 1.6\text{dB}$ Expanded Uncertainty $U = ku_c(y)$ $k = 2$ for 95% confidence

Notes: For "High Band" 927.6 MHz and 1855.2 MHz the CBL6140A Antenna was used.

RBW/VBW = 100KHz/100KHz

5.2.2.2 Restricted band measurements

Radiated emissions which fall in the restricted bands, as defined in 15.205(a), must also comply with the radiated emission limits specified in 15.209(a) (see 15.205(c)).

SOP 1 Radiated Emissions							Tracking # 30662118.001 Page 2 of 9			
EUT Name	Form 12S REX Meter					Date	21 August 2006			
EUT Model	ZC599A00000					Temp / Hum in	70 Deg F / 67%rh			
EUT Serial	06 210 289					Temp / Hum out	N/A			
Standard	FCC 47 CFR Part 15, RSS-210 Issue 6					Line AC / Freq.	120VAC 60Hz			
Deg/sweep						RBW / VBW	1MHz/1MHz			
Dist/Ant Used	3 meters 1Ghz -10GHz (3115-9903) 200MHz – 1GHz (SAS – 516)					Performed by	Randy Masline			
Configuration	Worst case Meter s/n 06210289 Channel 31“Low Band” 914.8 MHz Spurious Emissions									
Emission Freq (MHz)	ANT Polar (H/V)	ANT Pos (m)	Table Pos (deg)	FIM Value (dBuV)	Amp Gain (dB)	Cable Loss (dB)	ANT Factor (dB/m)	E-Field Value (dBuV/m)	Spec Limit (dBuV/m)	Spec Margin (dB)
Peak										
2744.00	H	1	43	39.60	35.34	6.78	29.24	40.27	74.00	-33.73
3659.00	H	1	48	38.40	34.90	8.05	31.59	43.14	74.00	-30.86
7318.00	H	1	48	38.50	35.01	13.69	36.16	53.33	74.00	-20.67
Average										
2744.00	H	1	43	27.00	35.34	6.78	29.24	27.67	54.00	-26.33
3659.00	H	1	48	25.98	34.90	8.05	31.59	30.72	54.00	-23.28
7318.00	H	1	48	26.20	35.01	13.69	36.16	41.03	54.00	-12.97
Spec Margin = E-Field Value - Limit, E-Field Value = FIM Value - Amp Gain + Cable Loss + ANT Factor ± Uncertainty										
Combined Standard Uncertainty $u_c(y) = \pm 1.6\text{dB}$ Expanded Uncertainty $U = ku_c(y)$ $k = 2$ for 95% confidence										
Notes: RBW/VBW = 1MHz/1MHz For frequencies between 1GHz and 10 GHz										

SOP 1 Radiated Emissions

Tracking # 30662118.001 Page 3 of 9

EUT Name	Form 12S REX Meter	Date	21 August 2006
EUT Model	ZC599A00000	Temp / Hum in	70 Deg F / 67%rh
EUT Serial	06 210 289	Temp / Hum out	N/A
Standard	FCC 47 CFR Part 15, RSS-210 Issue 6	Line AC / Freq.	120VAC 60Hz
Deg/sweep		RBW / VBW	1MHz/1MHz
Dist/Ant Used	3 meters 1Ghz -10GHz (3115-9903) 200MHz – 1GHz (SAS – 516)	Performed by	Randy Masline

Configuration Worst case Meter s/n 06210289 Channel 31 "Low Band" 914.8 MHz Spurious Emissions

Emission Freq (MHz)	ANT Polar (H/V)	ANT Pos (m)	Table Pos (deg)	FIM Value (dBuV)	Amp Gain (dB)	Cable Loss (dB)	ANT Factor (dB/m)	E-Field Value (dBuV/m)	Spec Limit (dBuV/m)	Spec Margin (dB)
Peak										
2744.00	V	1	43	42.20	35.34	6.78	29.23	42.87	74.00	-31.13
3659.00	V	1	43	38.40	34.90	8.05	31.52	43.07	74.00	-30.93
7318.00	V	1	43	38.90	35.01	13.69	36.04	53.62	74.00	-20.38
Average										
2744.00	V	1	43	32.20	35.34	6.78	29.23	32.87	54.00	-21.13
3659.00	V	1	43	27.00	34.90	8.05	31.52	31.67	54.00	-22.33
7318.00	V	1	43	26.20	35.01	13.69	36.04	40.92	54.00	-13.08

Spec Margin = E-Field Value - Limit, E-Field Value = FIM Value - Amp Gain + Cable Loss + ANT Factor ± Uncertainty

Combined Standard Uncertainty $u_c(y) = \pm 1.6\text{dB}$ Expanded Uncertainty $U = ku_c(y)$ $k = 2$ for 95% confidence

Notes: RBW/VBW = 1MHz/1MHz For frequencies between 1GHz and 10 GHz, Peak and Average measurements.

SOP 1 Radiated Emissions

Tracking # 30662118.001 Page 4 of 9

EUT Name	Form 12S REX Meter	Date	21 August 2006
EUT Model	ZC599A00000	Temp / Hum in	70 Deg F / 67%rh
EUT Serial	06 210 289	Temp / Hum out	N/A
Standard	FCC 47 CFR Part 15, RSS-210 Issue 6	Line AC / Freq.	120VAC 60Hz
Deg/sweep		RBW / VBW	1MHz/1MHz
Dist/Ant Used	3 meters 1Ghz -10GHz (3115-9903) 200MHz – 1GHz (SAS – 516)	Performed by	Randy Masline

Configuration Worst case Meter s/n 06210289 Channel 15 "Low Band" 908.4 MHz Spurious Emissions

Emission Freq (MHz)	ANT Polar (H/V)	ANT Pos (m)	Table Pos (deg)	FIM Value (dBuV)	Amp Gain (dB)	Cable Loss (dB)	ANT Factor (dB/m)	E-Field Value (dBuV/m)	Spec Limit (dBuV/m)	Spec Margin (dB)
Peak										
2725.00	H	1.33	0	45.31	35.35	6.75	29.18	45.89	74.00	-28.11
3633.00	H	1	13	40.10	34.96	8.02	31.52	44.68	74.00	-29.32
4542.00	H	1	48	40.90	35.13	9.08	32.24	47.08	74.00	-26.92
5440.00	H	1	48	40.70	34.75	10.05	33.94	49.94	74.00	-24.06
7267.00	H	1	48	38.30	35.01	13.67	36.04	52.99	74.00	-21.01
Average										
2725.00	H	1.33	0	34.40	35.35	6.75	29.18	34.98	54.00	-19.02
3633.00	H	1	13	30.00	34.96	8.02	31.52	34.58	54.00	-19.42
4542.00	H	1	48	29.00	35.13	9.08	32.24	35.18	54.00	-18.82
5440.00	H	1	48	28.10	34.75	10.05	33.94	37.34	54.00	-16.66
7267.00	H	1	48	26.00	35.01	13.67	36.04	40.69	54.00	-13.31

Spec Margin = E-Field Value - Limit, E-Field Value = FIM Value - Amp Gain + Cable Loss + ANT Factor ± Uncertainty

Combined Standard Uncertainty $u_c(y) = \pm 1.6\text{dB}$ Expanded Uncertainty $U = ku_c(y)$ $k = 2$ for 95% confidence

Notes: RBW/VBW = 1MHz/1MHz For frequencies between 1GHz and 10 GHz, Peak and Average measurements.

SOP 1 Radiated Emissions

Tracking # 30662118.001 Page 5 of 9

EUT Name	Form 12S REX Meter	Date	21 August 2006
EUT Model	ZC599A00000	Temp / Hum in	70 Deg F / 67%rh
EUT Serial	06 210 289	Temp / Hum out	N/A
Standard	FCC 47 CFR Part 15, RSS-210 Issue 6	Line AC / Freq.	120VAC 60Hz
Deg/sweep		RBW / VBW	1MHz/1MHz
Dist/Ant Used	3 meters 1Ghz -10GHz (3115-9903) 200MHz – 1GHz (SAS – 516)	Performed by	Randy Masline

Configuration Worst case Meter s/n 06210289 Channel 15 "Low Band" 908.4 MHz Spurious Emissions

Emission Freq (MHz)	ANT Polar (H/V)	ANT Pos (m)	Table Pos (deg)	FIM Value (dBuV)	Amp Gain (dB)	Cable Loss (dB)	ANT Factor (dB/m)	E-Field Value (dBuV/m)	Spec Limit (dBuV/m)	Spec Margin (dB)
Peak										
2725.00	V	1	68	46.60	35.35	6.75	29.17	47.18	74.00	-26.82
3633.00	V	1	68	40.30	34.96	8.02	31.45	44.81	74.00	-29.19
4542.00	V	1	44	38.90	35.13	9.08	32.24	45.08	74.00	-28.92
5440.00	V	1	44	40.20	34.75	10.05	33.93	49.42	74.00	-24.58
7267.00	V	1	74	38.50	35.01	13.67	35.91	53.07	74.00	-20.93
Average										
2725.00	V	1	68	33.10	35.35	6.75	29.17	33.68	54.00	-20.32
3633.00	V	1	68	30.10	34.96	8.02	31.45	34.61	54.00	-19.39
4542.00	V	1	44	27.40	35.13	9.08	32.24	33.58	54.00	-20.42
5440.00	V	1	44	28.10	34.75	10.05	33.93	37.32	54.00	-16.68
7267.00	V	1	74	26.00	35.01	13.67	35.91	40.57	54.00	-13.43

Spec Margin = E-Field Value - Limit, E-Field Value = FIM Value - Amp Gain + Cable Loss + ANT Factor ± Uncertainty

Combined Standard Uncertainty $u_c(y) = \pm 1.6\text{dB}$ Expanded Uncertainty $U = ku_c(y)$ $k = 2$ for 95% confidence

Notes: RBW/VBW = 1MHz/1MHz For frequencies between 1GHz and 10 GHz, Peak and Average measurements.

SOP 1 Radiated Emissions

Tracking # 30662118.001 Page 6 of 9

EUT Name	Form 12S REX Meter	Date	21 August 2006
EUT Model	ZC599A00000	Temp / Hum in	70 Deg F / 67%rh
EUT Serial	06 210 289	Temp / Hum out	N/A
Standard	FCC 47 CFR Part 15, RSS-210 Issue 6	Line AC / Freq.	120VAC 60Hz
Deg/sweep		RBW / VBW	1MHz/1MHz
Dist/Ant Used	3 meters 1Ghz -10GHz (3115-9903) 200MHz – 1GHz (SAS – 516)	Performed by	Randy Masline

Configuration Worst case Meter s/n 06210289 Channel 1 "Low Band" 902.8 MHz Spurious Emissions

Emission Freq (MHz)	ANT Polar (H/V)	ANT Pos (m)	Table Pos (deg)	FIM Value (dBuV)	Amp Gain (dB)	Cable Loss (dB)	ANT Factor (dB/m)	E-Field Value (dBuV/m)	Spec Limit (dBuV/m)	Spec Margin (dB)
Peak										
2708.00	H	1	46	42.77	35.34	6.74	29.12	43.29	74.00	-20.71
3611.00	H	1	0	40.00	34.99	8.00	31.47	44.48	74.00	-29.52
4514.00	H	1	43	38.90	35.11	9.06	32.18	45.04	74.00	-28.96
5147.00	H	1	43	40.00	34.74	9.83	33.42	48.51	74.00	-25.49
Average										
2708.00	H	1	46	32.40	35.34	6.74	29.12	32.92	54.00	-21.08
3611.00	H	1	0	28.40	34.99	8.00	31.47	32.88	54.00	-21.12
4514.00	H	1	43	26.30	35.11	9.06	32.18	32.44	54.00	-21.56
5147.00	H	1	43	27.00	34.74	9.83	33.42	35.51	54.00	-18.49

Spec Margin = E-Field Value - Limit, E-Field Value = FIM Value - Amp Gain + Cable Loss + ANT Factor ± Uncertainty

Combined Standard Uncertainty $u_c(y) = \pm 1.6\text{dB}$ Expanded Uncertainty $U = ku_c(y)$ $k = 2$ for 95% confidence

Notes: RBW/VBW = 1MHz/1MHz For frequencies between 1GHz and 10 GHz, Peak and Average measurements.

SOP 1 Radiated Emissions

Tracking # 30662118.001 Page 7 of 9

EUT Name	Form 12S REX Meter	Date	21 August 2006
EUT Model	ZC599A00000	Temp / Hum in	70 Deg F / 67%rh
EUT Serial	06 210 289	Temp / Hum out	N/A
Standard	FCC 47 CFR Part 15, RSS-210 Issue 6	Line AC / Freq.	120VAC 60Hz
Deg/sweep		RBW / VBW	1MHz/1MHz
Dist/Ant Used	3 meters 1Ghz -10GHz (3115-9903) 200MHz – 1GHz (SAS – 516)	Performed by	Randy Masline

Configuration Worst case Meter s/n 06210289 Channel 1 "Low Band" 902.8 MHz Spurious Emissions

Emission Freq (MHz)	ANT Polar (H/V)	ANT Pos (m)	Table Pos (deg)	FIM Value (dBuV)	Amp Gain (dB)	Cable Loss (dB)	ANT Factor (dB/m)	E-Field Value (dBuV/m)	Spec Limit (dBuV/m)	Spec Margin (dB)
Peak										
2708.00	V	1	43	46.50	35.34	6.74	29.11	47.01	74.00	-26.99
3611.00	V	1	43	39.00	34.99	8.00	31.39	43.41	74.00	-20.59
4514.00	V	1	43	39.50	35.11	9.06	32.17	45.63	74.00	-28.37
5147.00	V	1	43	39.80	34.74	9.83	33.46	48.35	74.00	-25.65
Average										
2708.00	V	1	43	35.00	35.34	6.74	29.11	35.51	54.00	-18.49
3611.00	V	1	43	26.60	34.99	8.00	31.39	31.01	54.00	-22.99
4514.00	V	1	43	27.10	35.11	9.06	32.17	33.23	54.00	-20.77
5147.00	V	1	43	27.00	34.74	9.83	33.46	35.55	54.00	-18.45

Spec Margin = E-Field Value - Limit, E-Field Value = FIM Value - Amp Gain + Cable Loss + ANT Factor ± Uncertainty

Combined Standard Uncertainty $u_c(y) = \pm 1.6\text{dB}$ Expanded Uncertainty $U = ku_c(y)$ $k = 2$ for 95% confidence

Notes: RBW/VBW = 1MHz/1MHz For frequencies between 1GHz and 10 GHz, Peak and Average measurements.

SOP 1 Radiated Emissions

Tracking # 30662118.001 Page 8 of 9

EUT Name	Form 12S REX Meter	Date	21 August 2006
EUT Model	ZC599A00000	Temp / Hum in	70 Deg F / 67%rh
EUT Serial	06 210 289	Temp / Hum out	N/A
Standard	FCC 47 CFR Part 15, RSS-210 Issue 6	Line AC / Freq.	120VAC 60Hz
Deg/sweep		RBW / VBW	1MHz/1MHz
Dist/Ant Used	3 meters 1Ghz -10GHz (3115-9903) 200MHz – 1GHz (SAS – 516)	Performed by	Randy Masline

Configuration Worst case Meter s/n 06210289 Channel 31 "High Band" 927.6 MHz Spurious Emissions

Emission Freq (MHz)	ANT Polar (H/V)	ANT Pos (m)	Table Pos (deg)	FIM Value (dBuV)	Amp Gain (dB)	Cable Loss (dB)	ANT Factor (dB/m)	E-Field Value (dBuV/m)	Spec Limit (dBuV/m)	Spec Margin (dB)
Peak										
2782.80	H	1	43	42.68	35.30	6.11	29.37	42.86	74.00	-31.14
3710.40	H	1	0	25.83	34.86	7.22	31.72	29.91	74.00	-44.09
4638.00	H	1	0	32.50	35.24	8.20	32.43	37.89	74.00	-36.11
Average										
2782.80	V	1	43	33.87	35.30	6.11	29.37	34.05	54.00	-19.92
3710.40	V	1	0	23.84	34.86	7.22	31.66	27.86	54.00	-26.14
4638.00	V	1	0	19.92	35.24	8.20	32.44	25.32	54.00	-28.68

Spec Margin = E-Field Value - Limit, E-Field Value = FIM Value - Amp Gain + Cable Loss + ANT Factor ± Uncertainty

Combined Standard Uncertainty $u_c(y) = \pm 1.6\text{dB}$ Expanded Uncertainty $U = ku_c(y)$ $k = 2$ for 95% confidence

Notes: RBW/VBW = 1MHz/1MHz For frequencies between 1GHz and 10 GHz

SOP 1 Radiated Emissions

Tracking # 30662118.001 Page 9 of 9

EUT Name	Form 12S REX Meter	Date	21 August 2006
EUT Model	ZC599A00000	Temp / Hum in	70 Deg F / 67%rh
EUT Serial	06 210 289	Temp / Hum out	N/A
Standard	FCC 47 CFR Part 15, RSS-210 Issue 6	Line AC / Freq.	120VAC 60Hz
Deg/sweep		RBW / VBW	1MHz/1MHz
Dist/Ant Used	3 meters 1Ghz -10GHz (3115-9903) 200MHz – 1GHz (SAS – 516)	Performed by	Randy Masline

Configuration Worst case Meter s/n 06210289 Channel 31 "High Band" 927.6 MHz Spurious Emissions

Emission Freq (MHz)	ANT Polar (H/V)	ANT Pos (m)	Table Pos (deg)	FIM Value (dBuV)	Amp Gain (dB)	Cable Loss (dB)	ANT Factor (dB/m)	E-Field Value (dBuV/m)	Spec Limit (dBuV/m)	Spec Margin (dB)
Peak										
2782.80	V	1	0	41.27	35.30	6.11	29.37	41.45	74.00	-32.55
3710.40	V	1	0	34.31	34.86	7.22	31.72	39.7	74.00	-34.3
4638.00	V	1	0	33.88	35.24	8.20	32.43	39.27	74.00	-34.73
Average										
2782.80	V	1	0	31.40	35.30	6.11	29.37	31.58	54.00	-22.42
3710.40	V	1	0	21.82	34.86	7.22	31.66	25.84	54.00	-28.16
4638.00	V	1	0	21.42	35.24	8.20	32.44	26.82	54.00	-27.18

Spec Margin = E-Field Value - Limit, E-Field Value = FIM Value - Amp Gain + Cable Loss + ANT Factor ± Uncertainty

Combined Standard Uncertainty $u_c(y) = \pm 1.6\text{dB}$ Expanded Uncertainty $U = ku_c(y)$ $k = 2$ for 95% confidence

Notes: RBW/VBW = 1MHz/1MHz For frequencies between 1GHz and 10 GHz, Peak and Average measurements.

5.3 Frequency Hopping Spread Spectrum Systems FCC Part 15.247(g)

Frequency hopping spread spectrum systems are not required to employ all available hopping channels during each transmission. However, the system, consisting of both the transmitter and the receiver, must be designed to comply with all of the regulations in this section should the transmitter be presented with a continuous data (or information) stream. In addition, a system employing short transmission bursts must comply with the definition of a frequency hopping system and must distribute its transmissions over the minimum number of hopping channels specified in this section.

When the REX Meter is presented with a continuous data stream, each 97.3 msec packet transmitted by the meter will be sent on the next channel in the 25-channel pseudo random list. When presented with a continuous data stream, the REX meter adheres to the 0.4 second dwell time for each 10 second window requirement. The REX Meter always distributes its transmissions across all 25 channels, and does not re-use a channel again until a transmission has occurred on each of the other 24 channels.

5.4 Incorporation of Intelligence within a Frequency Hopping Spread Spectrum System FCC Part 15.247(h)

The incorporation of intelligence within a frequency hopping spread spectrum system that permits the system to recognize other users within the spectrum band so that it individually and independently chooses and adapts its hopsets to avoid hopping on occupied channels is permitted. The coordination of frequency hopping systems in any other manner for the express purpose of avoiding the simultaneous occupancy of individual hopping frequencies by multiple transmitters is not permitted.

The REX meter does not attempt to recognize other users or interferers within the spectrum band and then attempt to select which channels to use. The REX Meter always distributes its transmissions across the same 25 channels. A channel is not re-used until a transmission has occurred on each of the other 24 channels.

5.5 Frequency Stability FCC Part 15.215(c)

The requirement to contain the 20 dB bandwidth of the emission within the specified frequency band includes effects from frequency sweeping, frequency hopping and other modulation techniques that may be employed as well as the frequency stability of the transmitter over expected variations in temperature and supply voltage.

Spectrum Analyzer Parameters:

RBW=30KHz

VBW=RBW

Span=1MHz

LOG dB/div.= 10dB

Sweep = 9.167 mS

Trigger Video

5.5.1 Containment of the Emission during Variations in Temperature

The EUT was placed in an environmental temperature test chamber, supplied with the normal AC voltage, and with an antenna attached to the output port. If the antenna is an adjustable length antenna, it will be fully extended. The monitoring device (ie. Spectrum analyzer) was then attached to a receive antenna placed 15 cm away from the EUT via coaxial cable.

The temperature inside the chamber is then raised to the highest temperature specified and allowed sufficient time for the temperature of the chamber to stabilize. While maintaining a constant temperature inside the environmental chamber, the carrier signal was then measured 40 min after temperature stabilization. Then the above process is repeated for the lowest temperature specified and 10 degree Centigrade increments between the extremes thereafter.

Results

Channel 1 "Low Band" (Modulated) 902.8 MHz

Temperature	Frequency in MHz measured 20dB below peak		Permitted Band Edge in MHz	Results
-30° C	902.476	903.124	902 - 928	Pass
-20° C	902.489	903.111	902 - 928	Pass
-10° C	902.495	903.105	902 - 928	Pass
0° C	902.489	903.111	902 - 928	Pass
10° C	902.476	903.124	902 - 928	Pass
20° C	902.594	903.086	902 - 928	Pass
30° C	902.525	903.075	902 - 928	Pass
40° C	902.536	903.064	902 - 928	Pass
50° C	902.536	903.064	902 - 928	Pass

Channel 31 "High Band" (Modulated) 927.6 MHz

Temperature	Frequency in MHz measured 20dB below peak		Permitted Band Edge in MHz	Results
-30° C	927.325	927.870	902 - 928	Pass
-20° C	927.325	927.870	902 - 928	Pass
-10° C	927.325	927.870	902 - 928	Pass
0° C	927.325	927.870	902 - 928	Pass
10° C	927.325	927.870	902 - 928	Pass
20° C	927.325	927.870	902 - 928	Pass
30° C	927.330	927.885	902 - 928	Pass
40° C	927.330	927.885	902 - 928	Pass
50° C	927.330	927.885	902 - 928	Pass

5.5.2 Containment of the Emission during Variations in Voltage

The setup was identical section 4.7.1 except the temperature inside of the chamber was set to 17 deg. C.

Channel 1 "Low Band" 902.8 MHz (Modulated)

Voltage	Frequency in MHz measured 20dB below peak		Permitted Band Edge in MHz	Results
120 VAC	902.469	903.131	902 - 928	Pass
102 VAC	902.463	903.137	902 - 928	Pass
138 VAC	902.485	903.115	902 - 928	Pass

Channel 31 "High Band" 927.6 MHz (Modulated)

Temperature	Frequency in MHz measured 20dB below peak		Permitted Band Edge in MHz	Results
120 VAC	927.330	927.885	902 - 928	Pass
102 VAC	927.330	927.880	902 - 928	Pass
138 VAC	927.330	927.890	902 - 928	Pass

Spectrum Analyzer Parameters:

RBW=30KHz

VBW=RBW

Span=1MHz

LOG dB/div.= 10dB

Sweep = 5 mS

Trigger Video

5.5.3 Photos



Figure 3 - Radiated Emissions Test Setup (Chamber – Front, X orientation)

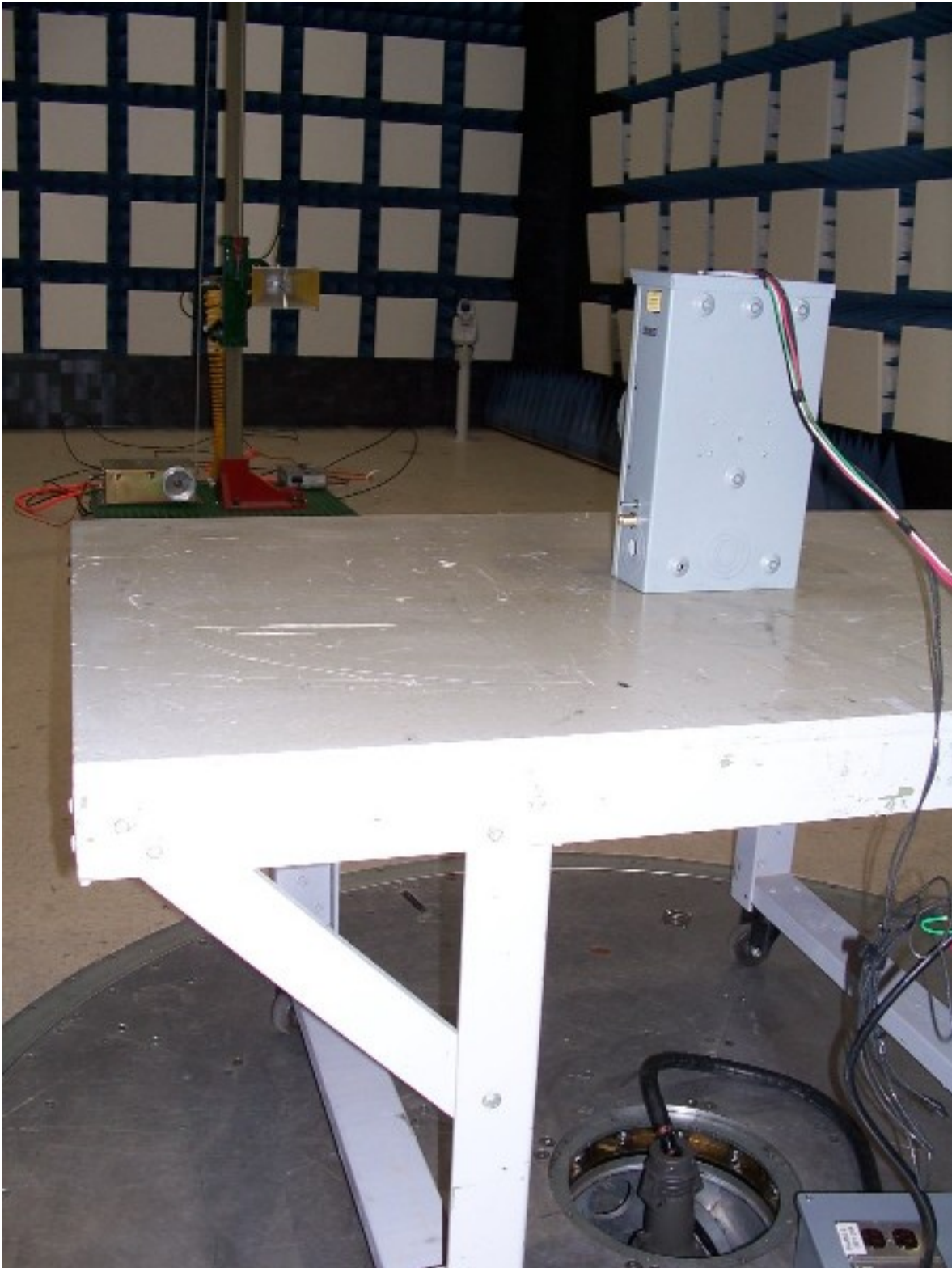

Figure 4 - Radiated Emissions Test Setup (Chamber – Back, X orientation)

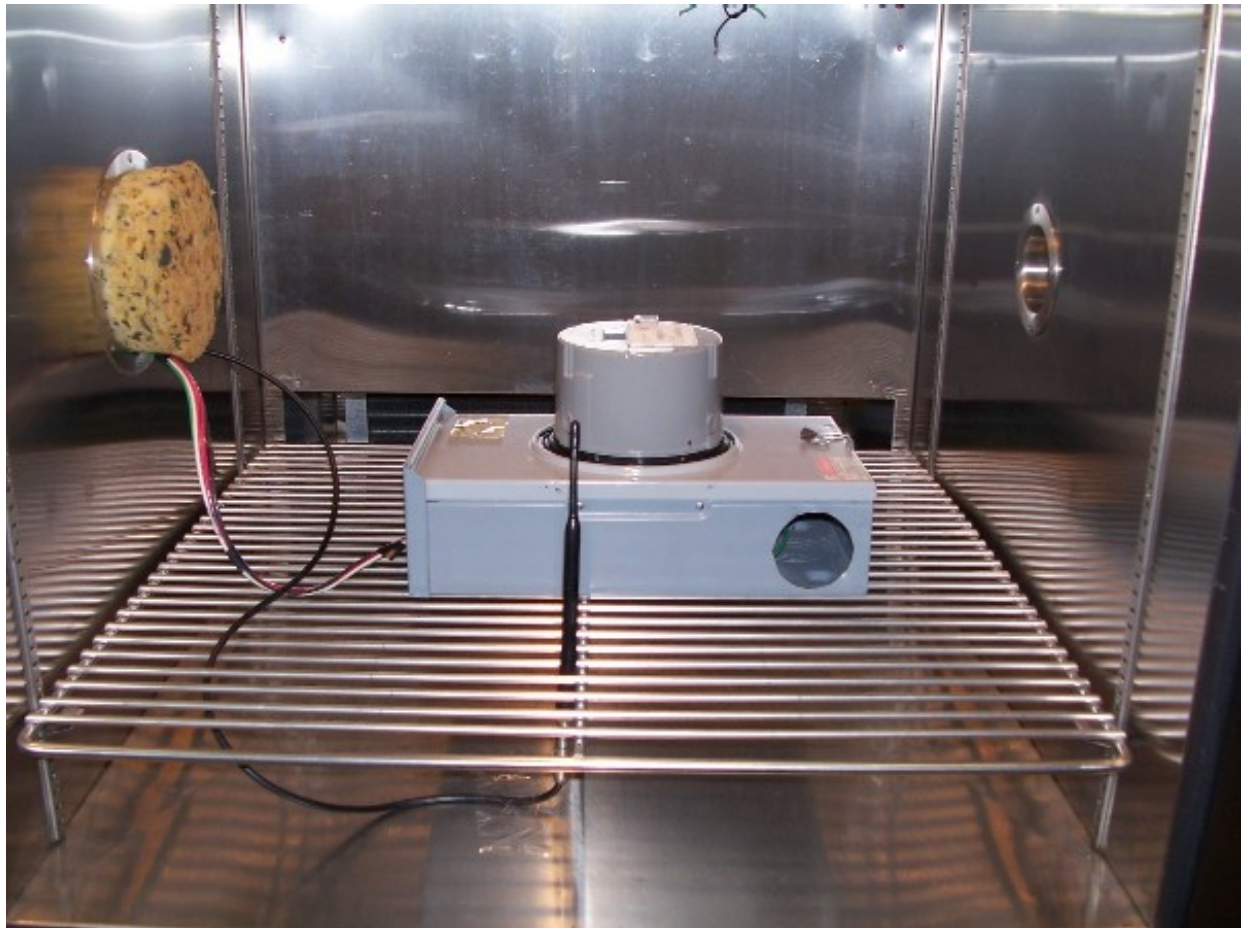

Figure 5 – Temperature Chamber Setup



Figure 6 – Setup for Substitution Method



Figure 7 – Setup for Conducted Power Measurements

5.5.4 Sample Calculation

The field strength is calculated by subtracting the Amplifier Gain and adding the Cable Loss and Antenna Correction Factor to the measured reading. The basic equation is as follows:

$$\text{Field Strength (dB}\mu\text{V/m)} = \text{FIM} - \text{AMP} + \text{CBL} + \text{ACF}$$

Where: FIM = Field Intensity Meter (dB μ V)
AMP = Amplifier Gain (dB)
CBL = Cable Loss (dB)
ACF = Antenna Correction Factor (dB/m)

$$\mu\text{V/m} = 10^{\frac{\text{dB}\mu\text{V} / \text{m}}{20}}$$

5.6 Conducted Emissions

Testing was performed in accordance with 47 CFR Part 15.207, ANSI C63.4:1992, RSS-210 Issue 5. These test methods are listed under the laboratory's NVLAP Scope of Accreditation.

This test measures the levels emanating from the EUT, thus evaluating the potential for the EUT to cause radio frequency interference to other electronic devices.

5.6.1 Test Methodology

A test program that controls instrumentation and data logging was used to automate the AC Power Line Conducted emission test procedure. The frequency range of interest was divided into sub-ranges such as to yield a frequency resolution of 9 kHz. For each frequency sub-range, each phase and neutral of the AC power line were measured with respect to ground. Measurements were performed using a set of 50 μ H / 50 Ω LISNs.

Testing is either performed in the anechoic chamber or on PLC Site 2. The setup photographs clearly identify which site was used. The vertical ground plane used in the anechoic chamber is a 2m x 2m wooden frame that is covered with ¼ inch hardware cloth and is bonded to the horizontal ground plane.

In the case of tabletop equipment, the EUT is placed on a 1.0m x 1.5m non-conductive table 80cm above the ground plane and 40cm from a vertical ground reference plane. The rear of the EUT was positioned flush with the backside of the table and directly over the LISNs. The power and I/O cables were routed over the edge of the table and bundled approximately 40cm from the ground plane. Support equipment was powered from a separate LISN.

5.6.1.1 Deviations

There were no deviations from this test methodology.

5.6.2 Test Results

Section 5.6.2.2 contains preliminary test data as well as any engineering data used to determine any modifications or special accessories. Section 5.6.2.1 lists the final measurement data under the worst case operating modes, configurations, and/or cable positions. It also reflects the results including any modifications and/or special accessories listed in Sections 1.4 and 1.5.

As originally tested, the EUT was found to be compliant to the requirements of the test standard(s).

Plots of the EUT's AC Line Conducted emissions are contained in the following sections. The plots show peak and/or average emissions and the corresponding peak and/or average limits. If the peak emissions are below the average limit, then the EUT is considered to pass and no average measurements are made. If the peak emissions are below the quasi-peak limit and the average emissions are below the average limit, then the EUT is considered to pass and no further measurements are made. Otherwise, individual frequencies are measured and compared to the corresponding limit for the detector used (quasi-peak or average).

5.6.2.1 Final Data

The data recorded in this section contains the final results under the worst-case conditions and with any modifications or special accessories implemented as the manufacturer intends.

SOP 2 Conducted Emissions

Tracking # 30662118.001 Page 1 of 4

EUT Name	Form 12S REX Meter	Date	21 August 2006
EUT Model	ZC599A00000	Temperature	76 Deg F
EUT Serial	06 210 289	Humidity	45% rh
Standard	FCC 47 CFR Part 15, RSS-210 Issue 6	Line AC /Freq	120VAC/60Hz
LISNs Used	6	Performed by	Randy Masline

Configuration

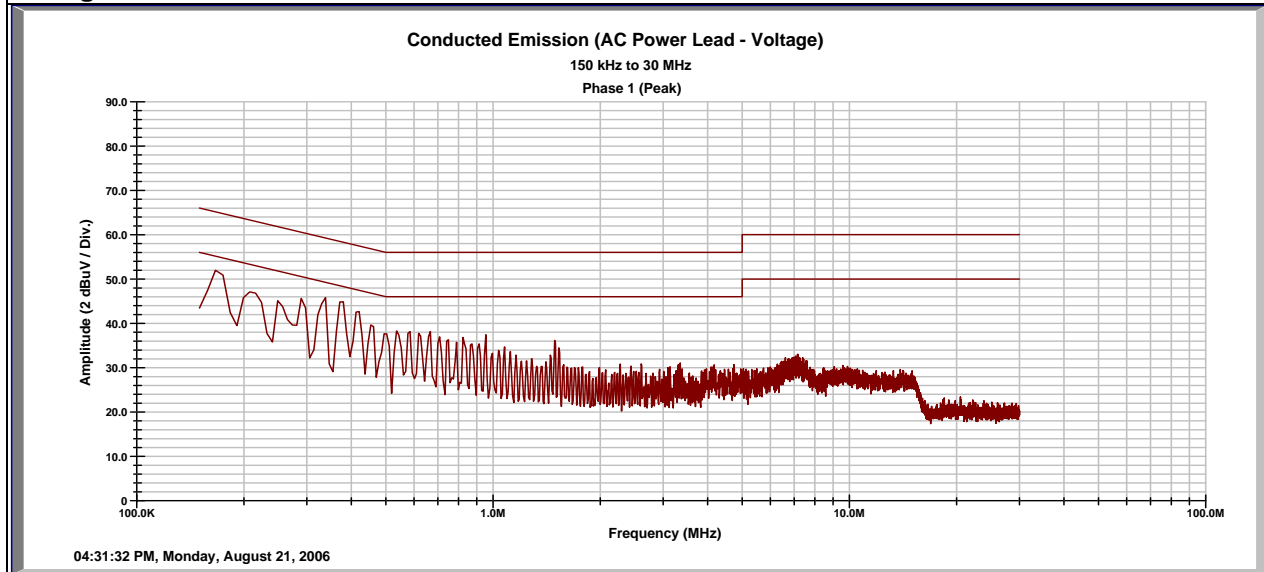

Emission Freq (MHz)	Line ID (1,2,3,N)	FIM Quasi (dBuV)	FIM Ave (dBuV)	Cable Loss (dB)	LISN + T Limiter (dB)	Quasi Limit (dBuV)	Ave Limit (dBuV)	Quasi Spec Margin (dB)	Ave Spec Margin (dB)
0.16	1	43.45	39.34	0.00	10.02	65.21	55.21	-11.74	-5.85
0.29	1	37.87	28.82	0.01	10.02	60.55	50.55	-12.65	-11.70
0.33	1	40.88	35.15	0.01	10.02	59.45	49.45	-8.54	-4.27
0.37	1	37.97	31.61	0.01	10.03	58.50	48.50	-10.49	-6.85
0.41	1	39.10	32.82	0.01	10.03	57.61	47.61	-8.47	-4.75
1.40	1	22.06	19.73	0.03	10.05	56.00	46.00	-23.86	-16.19

Quasi Spec Margin = Quasi FIM + Cable Loss + LISN CF - Quasi Limit ± Uncertainty

Ave Spec Margin = Ave FIM + Cable Loss + LISN CF - Ave Limit ± Uncertainty

Combined Standard Uncertainty $u_c(y) = \pm 1.2\text{dB}$ Expanded Uncertainty $U = k u_c(y)$ $k = 2$ for 95% confidence

Notes:

SOP 2 Conducted Emissions

Tracking # 30662118.001 Page 2 of 4

EUT Name	Form 12S REX Meter	Date	21 August 2006
EUT Model	ZC599A00000	Temperature	76 Deg F
EUT Serial	06 210 289	Humidity	45% rh
Standard	FCC 47 CFR Part 15, RSS-210 Issue 6	Line AC /Freq	120VAC/60Hz
LISNs Used	6	Performed by	Randy Masline

Configuration

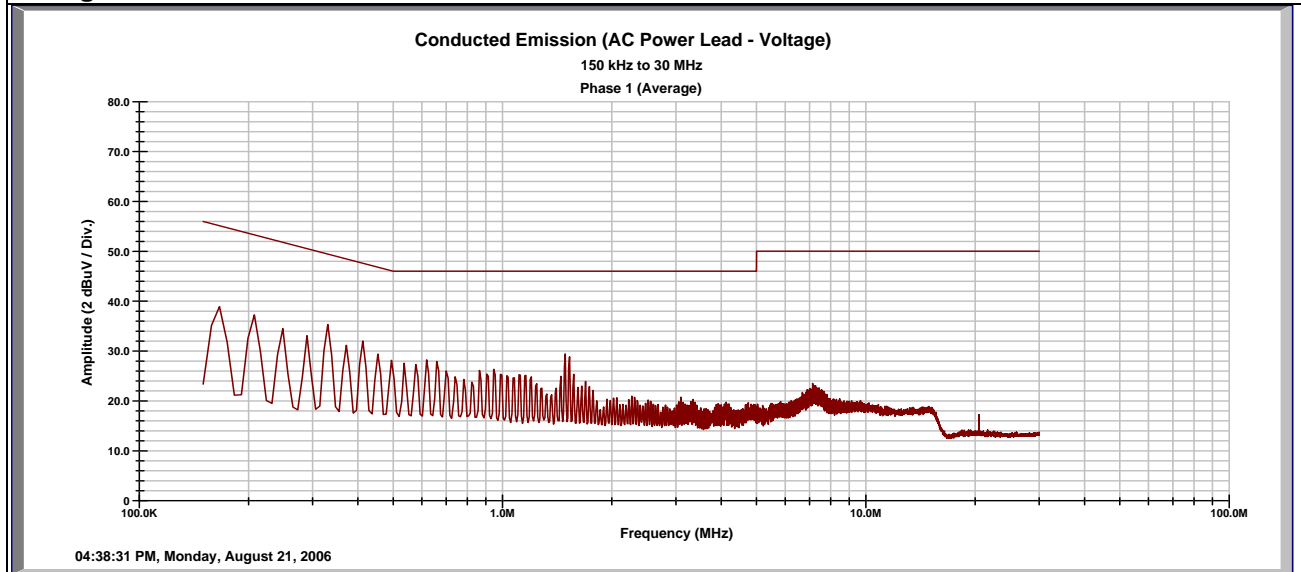

Emission Freq (MHz)	Line ID (1,2,3,N)	FIM Quasi (dBuV)	FIM Ave (dBuV)	Cable Loss (dB)	LISN + T Limiter (dB)	Quasi Limit (dBuV)	Ave Limit (dBuV)	Quasi Spec Margin (dB)	Ave Spec Margin (dB)

Quasi Spec Margin = Quasi FIM + Cable Loss + LISN CF - Quasi Limit ± Uncertainty
 Ave Spec Margin = Ave FIM + Cable Loss + LISN CF - Ave Limit ± Uncertainty
 Combined Standard Uncertainty $u_c(y) = \pm 1.2\text{dB}$ Expanded Uncertainty $U = k u_c(y)$ $k = 2$ for 95% confidence

Notes:

SOP 2 Conducted Emissions

Tracking # 30662118.001 Page 3 of 4

EUT Name	Form 12S REX Meter	Date	22 August 2006
EUT Model	ZC599A00000	Temperature	70 Deg F
EUT Serial	06 210 289	Humidity	66% rh
Standard	FCC 47 CFR Part 15, RSS-210 Issue 6	Line AC /Freq	120VAC/60Hz
LISNs Used	7	Performed by	Randy Masline

Configuration

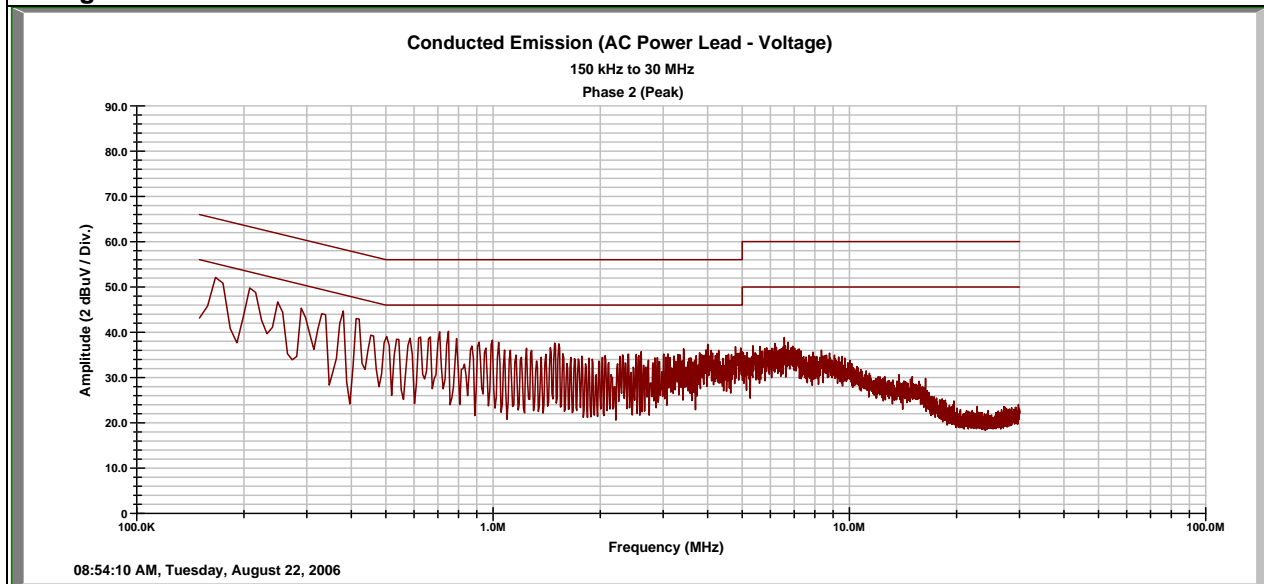

Emission Freq (MHz)	Line ID (1,2,3,N)	FIM Quasi (dBuV)	FIM Ave (dBuV)	Cable Loss (dB)	LISN + T Limiter (dB)	Quasi Limit (dBuV)	Ave Limit (dBuV)	Quasi Spec Margin (dB)	Ave Spec Margin (dB)
0.17	N	43.01	39.35	0.00	9.92	65.16	55.16	-12.23	-5.89
0.21	N	42.29	37.13	0.00	9.92	63.32	53.32	-11.11	-6.27
0.25	N	39.34	33.44	0.01	9.92	61.82	51.82	-12.55	-8.45
0.29	N	39.42	29.45	0.01	9.92	60.58	50.58	-11.23	-11.20
0.37	N	36.55	30.65	0.01	9.93	58.43	48.43	-11.95	-7.85
0.41	N	38.61	33.07	0.01	9.93	57.59	47.59	-9.04	-4.58

Quasi Spec Margin = Quasi FIM + Cable Loss + LISN CF - Quasi Limit ± Uncertainty

Ave Spec Margin = Ave FIM + Cable Loss + LISN CF - Ave Limit ± Uncertainty

Combined Standard Uncertainty $u_c(y) = \pm 1.2\text{dB}$ Expanded Uncertainty $U = k u_c(y)$ $k = 2$ for 95% confidence

Notes:

SOP 2 Conducted Emissions

Tracking # 30662118.001 Page 4 of 4

EUT Name	Form 12S REX Meter	Date	22 August 2006
EUT Model	ZC599A00000	Temperature	70 Deg F
EUT Serial	06 210 289	Humidity	66% rh
Standard	FCC 47 CFR Part 15, RSS-210 Issue 6	Line AC /Freq	120VAC/60Hz
LISNs Used	7	Performed by	Randy Masline

Configuration

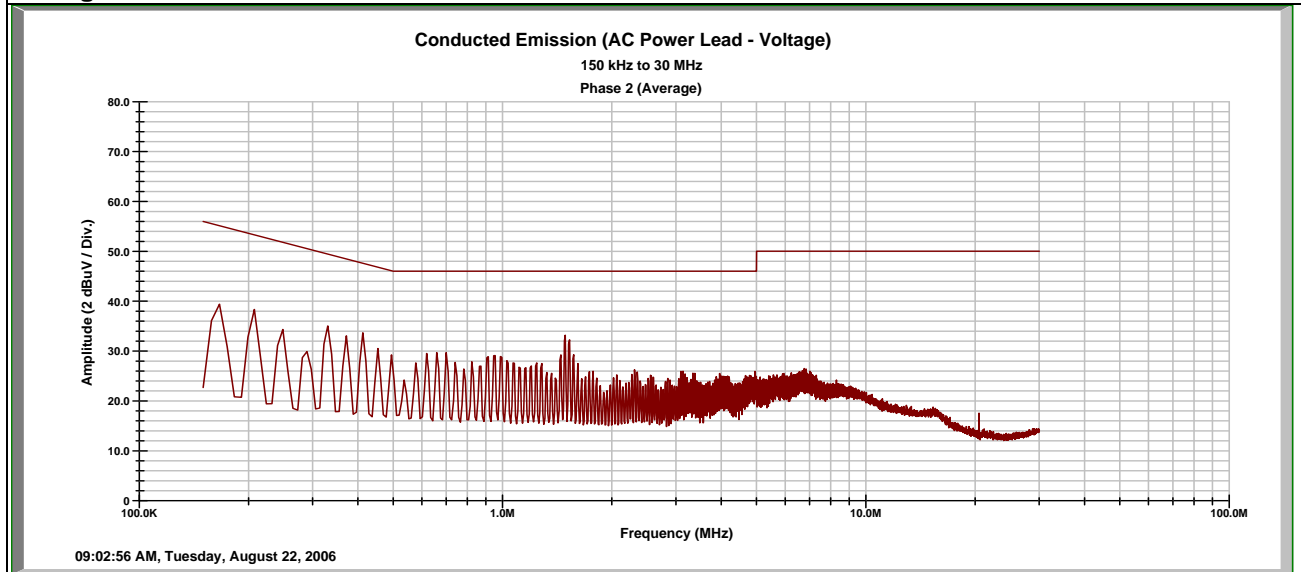

Emission Freq (MHz)	Line ID (1,2,3,N)	FIM Quasi (dBuV)	FIM Ave (dBuV)	Cable Loss (dB)	LISN + T Limiter (dB)	Quasi Limit (dBuV)	Ave Limit (dBuV)	Quasi Spec Margin (dB)	Ave Spec Margin (dB)

Quasi Spec Margin = Quasi FIM + Cable Loss + LISN CF - Quasi Limit ± Uncertainty
 Ave Spec Margin = Ave FIM + Cable Loss + LISN CF - Ave Limit ± Uncertainty
 Combined Standard Uncertainty $u_c(y) = \pm 1.2\text{dB}$ Expanded Uncertainty $U = k u_c(y)$ $k = 2$ for 95% confidence

Notes:

5.6.2.2 Engineering Data

The data recorded in this section includes pre-scans, informational, and engineering data included for reference only. This data was used to select worst-case operating modes and configurations to identify frequencies to measure. If any modifications or special accessories were required, the supporting data is contained in this section.

SOP 2 Conducted Emissions

Tracking # 30662118.001 Page 1 of

EUT Name	Form 12S REX Meter	Date	22 August 2006
EUT Model	ZC599A00000	Temperature	70 Deg F
EUT Serial	06 210 290	Humidity	66% rh
Standard	FCC 47 CFR Part 15, RSS-210 Issue 6	Line AC /Freq	240VAC/60Hz
LISNs Used	6	Performed by	Randy Masline

Configuration

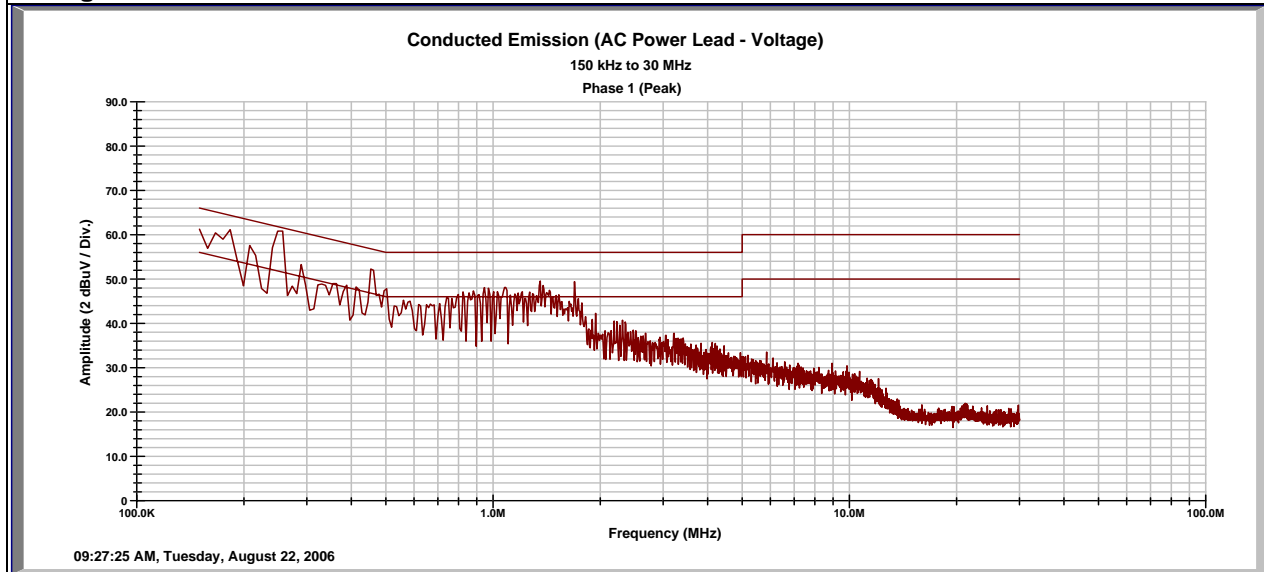

Emission Freq (MHz)	Line ID (1,2,3,N)	FIM Quasi (dBuV)	FIM Ave (dBuV)	Cable Loss (dB)	LISN + T Limiter (dB)	Quasi Limit (dBuV)	Ave Limit (dBuV)	Quasi Spec Margin (dB)	Ave Spec Margin (dB)
0.18	1	45.24	38.59	0.01	10.02	64.58	54.58	-9.31	-5.96
0.20	1	43.36	38.43	0.01	10.02	63.49	53.49	-10.10	-5.03
0.26	1	43.44	38.63	0.01	10.02	61.30	51.30	-7.83	-2.64
0.47	1	38.71	33.54	0.02	10.03	56.51	46.51	-7.75	-2.92
1.35	1	39.98	32.80	0.03	10.05	56.00	46.00	-5.94	-3.12
1.69	1	36.01	29.53	0.03	10.06	56.00	46.00	-9.90	-6.38

Quasi Spec Margin = Quasi FIM + Cable Loss + LISN CF - Quasi Limit ± Uncertainty

Ave Spec Margin = Ave FIM + Cable Loss + LISN CF - Ave Limit ± Uncertainty

Combined Standard Uncertainty $u_c(y) = \pm 1.2\text{dB}$ Expanded Uncertainty $U = k u_c(y)$ $k = 2$ for 95% confidence

Notes:

SOP 2 Conducted Emissions

Tracking # 30662118.001 Page 1 of

EUT Name	Form 12S REX Meter	Date	22 August 2006
EUT Model	ZC599A00000	Temperature	70 Deg F
EUT Serial	06 210 290	Humidity	66% rh
Standard	FCC 47 CFR Part 15, RSS-210 Issue 6	Line AC /Freq	240VAC/60Hz
LISNs Used	6	Performed by	Randy Masline

Configuration

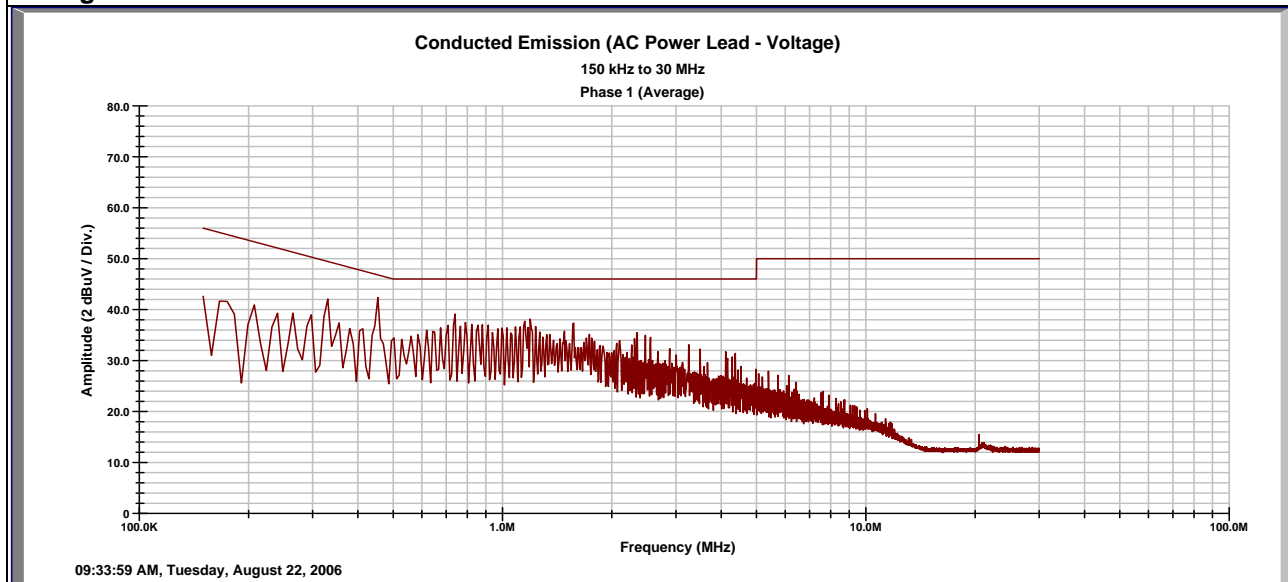

Emission Freq (MHz)	Line ID (1,2,3,N)	FIM Quasi (dBuV)	FIM Ave (dBuV)	Cable Loss (dB)	LISN + T Limiter (dB)	Quasi Limit (dBuV)	Ave Limit (dBuV)	Quasi Spec Margin (dB)	Ave Spec Margin (dB)

Quasi Spec Margin = Quasi FIM + Cable Loss + LISN CF - Quasi Limit ± Uncertainty
 Ave Spec Margin = Ave FIM + Cable Loss + LISN CF - Ave Limit ± Uncertainty
 Combined Standard Uncertainty $u_c(y) = \pm 1.2\text{dB}$ Expanded Uncertainty $U = k u_c(y)$ $k = 2$ for 95% confidence

Notes:

SOP 2 Conducted Emissions

Tracking # 30662118.001 Page 1 of

EUT Name	Form 12S REX Meter	Date	22 August 2006
EUT Model	ZC599A00000	Temperature	70 Deg F
EUT Serial	06 210 290	Humidity	66% rh
Standard	FCC 47 CFR Part 15, RSS-210 Issue 6	Line AC /Freq	240VAC/60Hz
LISNs Used	7	Performed by	Randy Masline

Configuration

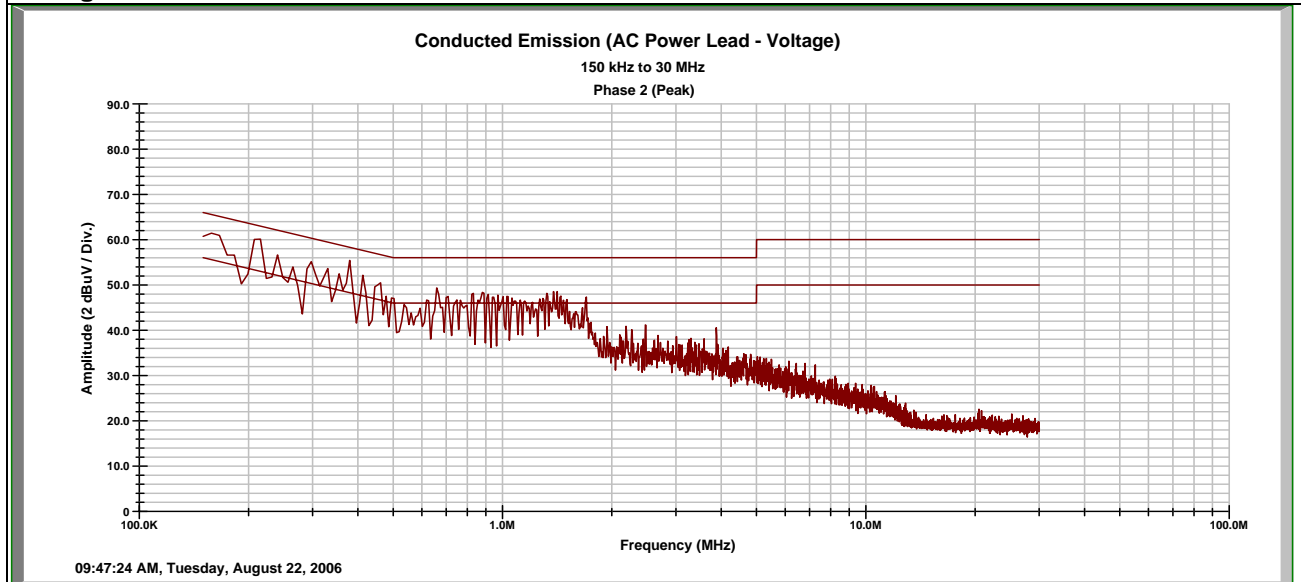

Emission Freq (MHz)	Line ID (1,2,3,N)	FIM Quasi (dBuV)	FIM Ave (dBuV)	Cable Loss (dB)	LISN + T Limiter (dB)	Quasi Limit (dBuV)	Ave Limit (dBuV)	Quasi Spec Margin (dB)	Ave Spec Margin (dB)
0.17	N	45.20	37.53	0.00	9.92	65.16	55.16	-10.04	-7.71
0.21	N	43.33	38.34	0.00	9.92	63.32	53.32	-10.07	-5.06
0.29	N	42.47	37.44	0.01	9.92	60.44	50.44	-8.04	-3.07
0.38	N	40.63	34.29	0.01	9.93	58.26	48.26	-7.69	-4.03
0.41	N	45.71	37.13	0.01	9.93	57.63	47.63	-1.98	-0.56
0.46	N	33.74	25.43	0.01	9.93	56.75	46.75	-13.07	-11.38

Quasi Spec Margin = Quasi FIM + Cable Loss + LISN CF - Quasi Limit ± Uncertainty

Ave Spec Margin = Ave FIM + Cable Loss + LISN CF - Ave Limit ± Uncertainty

Combined Standard Uncertainty $u_c(y) = \pm 1.2\text{dB}$ Expanded Uncertainty $U = k u_c(y)$ $k = 2$ for 95% confidence

Notes:

SOP 2 Conducted Emissions

Tracking # 30662118.001 Page 1 of

EUT Name	Form 12S REX Meter	Date	22 August 2006
EUT Model	ZC599A00000	Temperature	70 Deg F
EUT Serial	06 210 290	Humidity	66% rh
Standard	FCC 47 CFR Part 15, RSS-210 Issue 6	Line AC /Freq	240VAC/60Hz
LISNs Used	7	Performed by	Randy Masline

Configuration

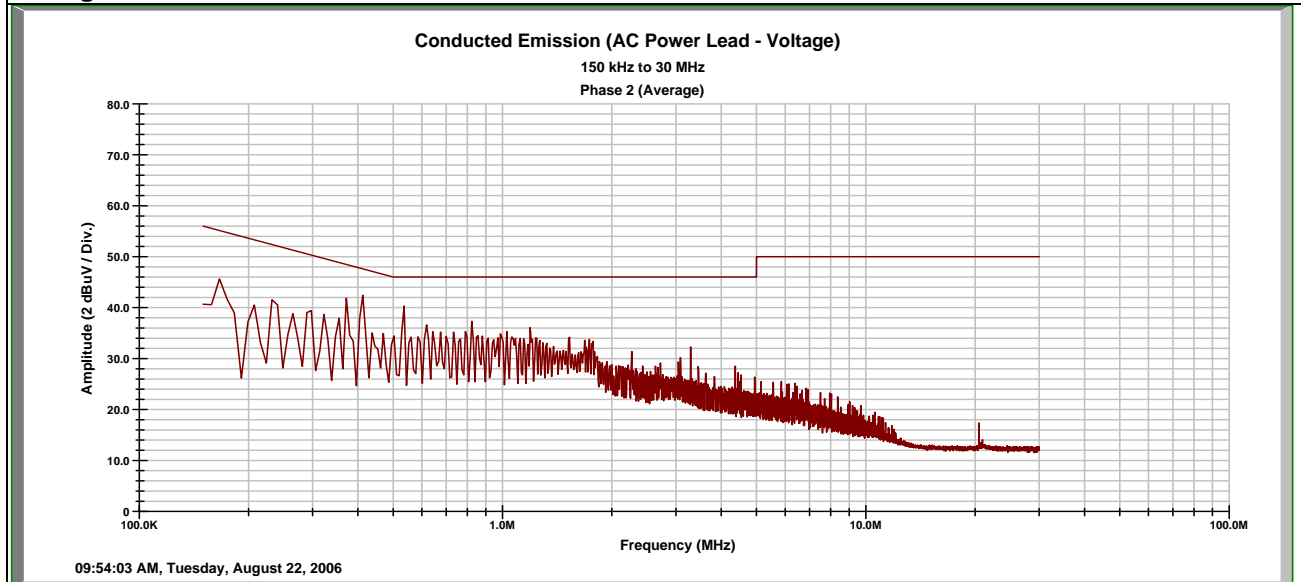

Emission Freq (MHz)	Line ID (1,2,3,N)	FIM Quasi (dBuV)	FIM Ave (dBuV)	Cable Loss (dB)	LISN + T Limiter (dB)	Quasi Limit (dBuV)	Ave Limit (dBuV)	Quasi Spec Margin (dB)	Ave Spec Margin (dB)

Quasi Spec Margin = Quasi FIM + Cable Loss + LISN CF - Quasi Limit ± Uncertainty
 Ave Spec Margin = Ave FIM + Cable Loss + LISN CF - Ave Limit ± Uncertainty
 Combined Standard Uncertainty $u_c(y) = \pm 1.2\text{dB}$ Expanded Uncertainty $U = k u_c(y)$ $k = 2$ for 95% confidence

Notes:

5.6.3 Photos

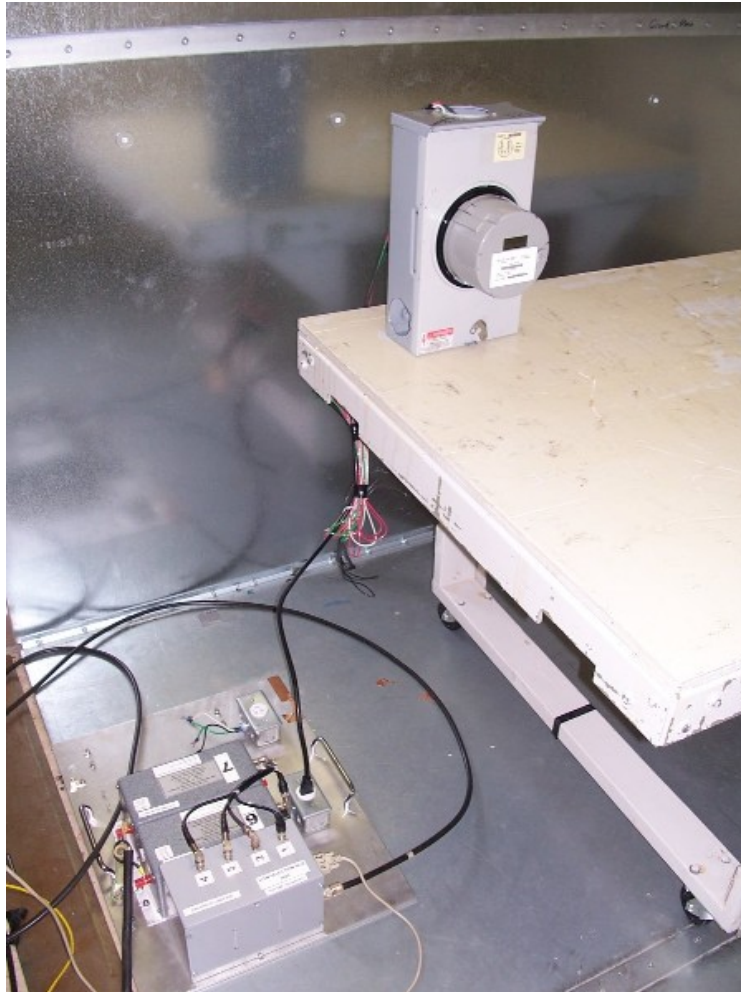

Figure 8 - Conducted Emissions Test Setup (Front)

5.6.4 Sample Calculation

The signal strength is calculated by adding the LISN Correction Factor and Cable Loss to the measured reading. The basic equation is as follows:

$$\text{Field Strength (dB}\mu\text{V/m)} = \text{FIM} + \text{CBL} + \text{LCF}$$

Where: FIM = Field Intensity Meter (dB μ V)

CBL = Cable Loss (dB)

LCF = LISN Loss (dB)

$$\mu\text{V/m} = 10^{\frac{\text{dB}\mu\text{V/m}}{20}}$$

6 Test Equipment Use List

Equipment	Manufacturer	Model #	Serial/Inst #	Last Cal dd/mm/yy	Next Cal dd/mm/yy
SOP 1 - Radiated Emissions (5 Meter Chamber)					
Amplifier, preamp	Hewlett Packard	8449B	3008A00268	05-Aug-06	05-Aug-07
Ant. Log Periodic	AH Systems	SAS-516	133	13-Mar-06	13-Mar-07
Antenna Horn	EMCO	3115	9903.5770	28 -Apr -06	28 -Apr-07
Ant. Dipole Set BL 1-4	EMCO	3121C	9302-914	9-Sep-05	9-Sep-06
Cable, Coax	Andrew	FSJ1-50A	031	18-Jan-06	18-Jan-07
Cable, Coax	Andrew	FSJ1-50A	041	18-Jan-06	18-Jan-07
Cable, Coax	Andrew	FSJ1-50A	042	18-Jan-06	18-Jan-07
Cable, Coax	Andrew	FSJ1-50A	045	18-Jan-06	18-Jan-07
Chamber, Semi-Anechoic	Braden Shielding	5 meter	A67631	27-Jan-06	27-Jan-07
Data Table, EMCWin	TUV EMC	EMCWin.dll	002	N/A	N/A
Spectrum Analyzer	Rohde & Schwarz	ESI 40	1088.7490	22-Dec-05	22-Dec-06

SOP 2 - Conducted Emissions (AC/DC and Signal I/O)					
Cable, Coax	Belden	RG-213	004	18-Jan-06	18-Jan-07
LISN (5) 50mH/50Ω	Solar Electronics	8028-50-TS-24	990441	5-Aug-06	5-Aug-07
LISN (6) 50mH/50Ω	Solar Electronics	8028-50-TS-24	990442	5-Aug-06	5-Aug-07
LISN Selection Box	TUV Rheinland	CFL-9206	1650	26-Sep-05	26-Sep-06
Spectrum Analyzer	Agilent Tec.	E7405A	US39440157	27-Feb-06	27-Feb-07
Cable, Coax	Belden	RG-213	004	18-Jan-06	18-Jan-07
General Laboratory Equipment					
Meter, Multi	Fluke	79-3	69200606	5-Aug-06	5-Aug-07
Meter, Temp/Humid/Barom	Fisher	02-400	01	24-Oct-05	24-Oct-06
Power Supply, AC	California Instruments	1251P	L06429	CNR II	CNR II

* Calibration of equipment past due for re-calibration will be performed expeditiously. If any equipment is found to be out of tolerance at that time, affected customers will be notified accordingly.

7 EMC Test Plan

7.1 Introduction

This manufacturer-supplied document provides a description of the Equipment Under Test (EUT), configuration(s), operating condition(s), and performance acceptance criteria. It is intended to provide the test laboratory with the essential information needed to perform the requested testing.

Customer

The information in the following tables is required, as it should appear in the final test report.

Table 2 – Manufacturer Information

Company Name:	Elster Electricity, LLC
Street Address:	208 South Rogers Lane
City, State, Zip Code:	Raleigh, NC 27610
Tel:	919-212-4700
Fax:	919-212-5108

Table 3 – Technical Contact Information

Contact Name	Telephone	Fax	Email address
Bob Mason	919-212-5086	919-250-5486	robert.t.mason@us.elster.com

Equipment Under Test (EUT)

The information provided in the following table is listed as it should appear in the final report. Note, the “*” characters in the model/style numbers designate “don’t care” values and the field can be multiple values to indicate the specific single phase form or to indicate specific customer options. These options do not change the electronic module and are considered equivalent styles. Refer to Section 0 - Equivalent Models. The following four meters will be tested and the worst-case meter will be used to file the FCC report.

Table 4 – EUT Designation

EUT	Model Name	Model Number (Elster Style Number)
Singlephase REX Meters (R1S)	REX Meter R1S	ZC**9000000
Singlephase REX meters with internal service disconnect switch (R1SD)	REX Meter R1SD	ZC**9A00000
Form 12S REX Meter (R1S)	REX Meter R1S	ZC5*9000000
Form 12S REX meter with internal service disconnect switch (R1SD)	REX Meter R1SD	ZC5*9A00000

Technical Description

Background

The REX Meter has previously been tested by TUV and certified by the FCC as a frequency hopping device operating in the 902-915 MHz region of the ISM band. New firmware in the board now allows the 25 channels used by the product to be selected, where center frequencies between 902.4 MHz and 927.6 MHz can be selected. In addition, for each channel, the product can be configured to use low or high side injection. The REX meter will support two networks, one for LAN traffic and one for in-home display communications. The LAN is the primary network, and the in-home display is the secondary network. The 25 channels used for the primary network are selectable between 902.4 and 927.6 MHz. When enabled, the secondary network uses the same set of channels or applies a 12.8 MHz offset to the channel

used by the primary network. For example, if the primary network was configured to use 25 channels between 902.4 and 914.8 MHz, the secondary network may be configured to use 25 channels between 915.2 and 927.6 MHz. The product requires all channels to be between 902.4 and 927.6 MHz.

In addition to the firmware change that allows the selection of the low or high band, a receive path SAW filter has been changed from a 902-920 MHz bandpass to a 902-928 MHz bandpass. To reduce the time required to certify the product, the boards submitted will have the SAW filter removed completely, as this is a worst case scenario (from an emissions perspective) as compared to having the SAW filter in the circuit.

Device Type

The REX Meter is an intentional radiator and is classified as a Part 15.247 device. The critical specifications of the REX Meter are listed in the following table:

Frequency Band	902.8 – 927.6 MHz
Classification	Frequency Hopping Spread Spectrum
Maximum Output Power	0.25W (+24 dBm)
Channel Spacing	400 kHz
Channel 20 dB Bandwidth	325 kHz
Number of Channels	25 (per network)
Max channel dwell time within a 10 second period	< 0.4 seconds NOTE: The meter only transmits on one network at a time. Both are 25 channel FHSS networks.

Electronic Assembly Description

Description of Circuit Function

The REX Meter electronic assembly implements a single-phase watt-hour meter, with an integrated 900 MHz, frequency hopping spread spectrum radio. The block diagram in Figure 9 shows the major sections of the electronic assembly:

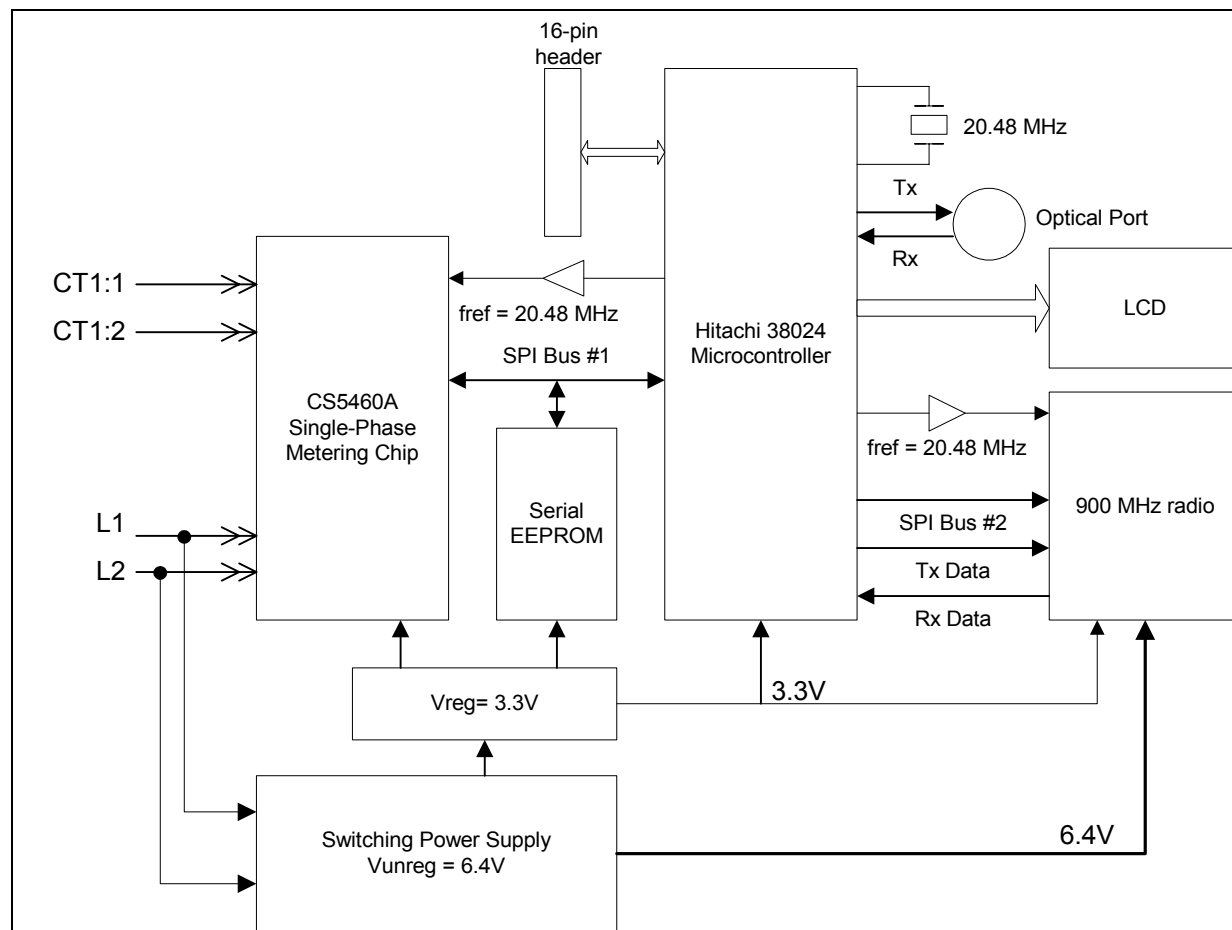

Figure 9: REX Meter Block Diagram

- L1 and L2** Line voltage is brought to the board via 2 pads, L1 and L2, one on the top side of the PCB, and one on the bottom side of the PCB. Line voltage potential will range from 96 to 288 volts between L1 and L2. From the outside of the meter, line voltage is connected via voltage blades, where the voltage applied and the blades to apply the voltage depend on the meter form.
- CT1:1, CT1:2** Current signals from an off-board current transformer (CT) are brought to the board through a 2-pin connector. Potentials at CT1 are low voltage, ranging from 250 mV to less than 75 μ V.
- Microcontroller** An 80-pin, 0.50 mm pitch microcontroller.
- LCD** The LCD is mounted in the PCB with a single row of 17 pins. The data displayed on the LCD is configurable, but the meter will typically display electrical energy

consumption (i.e. kWh).

900 MHz radio	The 900 MHz radio block consists of a TI6900 RF transceiver chip, a voltage controlled oscillator, a low noise amplifier (LNA), a power amplifier (PA), a Transmit/Receive Switch, and a circuit board mounted antenna. A detailed block diagram of the radio is shown in Figure 10. Note that the TI5901 RF transceiver chip is an equivalent part to the TI6900, except that the TI5901 has a specified operating temperature of -40°C to $+85^{\circ}\text{C}$, and the TI6900 has a specified operating temperature of -20°C to $+60^{\circ}\text{C}$.
Power Supply	A switching power supply provides an unregulated 6.4V for the RF transmitter and feeds a regulator that provides a 3.3V regulated voltage.
EEPROM	The serial EEPROM provides storage for configuration information and metering data.
Interface Signals	There is an optical port for serial communications with the microcontroller and a 16-pin header that will allow communications with future option boards. Both of these ports use a fixed baud rate of 4800 bits/sec. The optical port will be used to configure the REX Meter into various normal and test modes of operation to facilitate FCC testing.

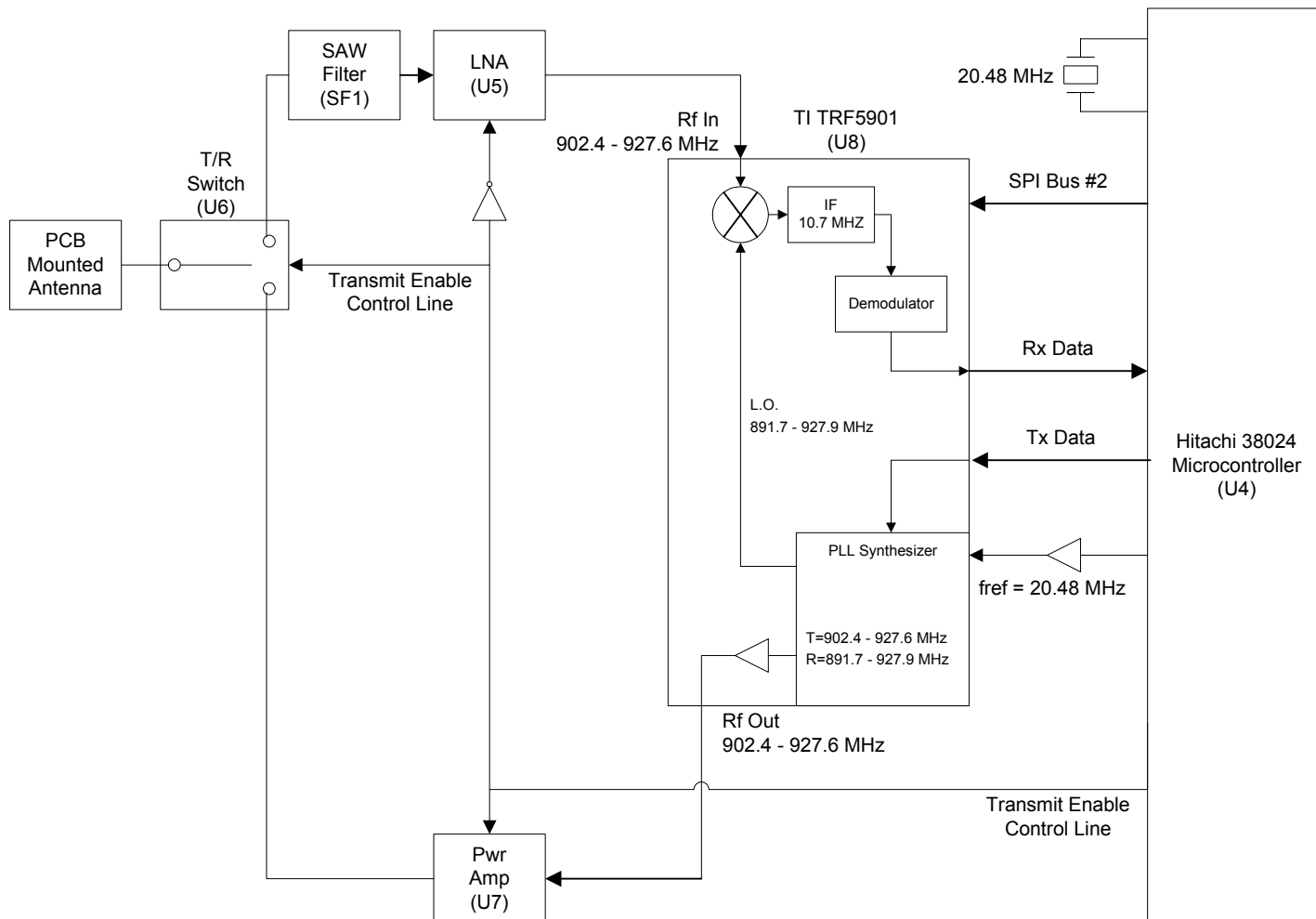

Figure 10: Radio Block Diagram

SPI Bus #2	In normal operation, the radio is in receive mode and is hopping across 25 channels searching for a message to receive. SPI Bus #2 is used to: <ul style="list-style-type: none"> • configure the TI6900 to the correct frequency • place the TI6900 in transmit or receive mode
Tx Data	In normal operation, when transmitting, the microcontroller sends manchester encoded data to the TI6900 at the manchester data rate of 17.705 kbps. Each packet that is sent is 97.3 msec in duration. Each new packet transmitted is on the next channel in the pseudo-random list of 25 channels used by the REX Meter.
SF1	On previously submitted REX meters, SF1 was a 902-920 MHz bandpass filter. SF1 is in the process of changing to a

902-928 MHz bandpass filter. For the units submitted, SF1 has been removed (bypassed). A future permissible change will add a 902-928 bandpass filter.

Antenna

The antenna is a planar inverted F antenna approximately 1.3 inches in height and 2.7 inches in length with an integral ground-plane structure that solders into the printed-circuit board as shown in the attached drawing.

Rf Channel Plan

The REX Meter is capable of communicating on two networks, one for primary LAN communications and one for secondary in-home communications. The two networks both use 25 channels, frequency hopping spread spectrum communications. The channels selected for use in either band can be selected as any channel between 902.4 and 927.6 MHz. For each channel, the channel can be configured for the receiver to use low side or high side injection.

The 20 dB bandwidth of each channel is approximately 325 kHz and the average time of occupancy on any frequency is less than 0.4 seconds within a 10 second period. In a constant transmit mode, the REX Meter would send a packet every 97.3 msec with a delay of 8 to 16 msec between packets. Each packet is sent on the next channel in the pseudo-random channel list. In 10 seconds, the REX Meter would send no more than 95 packets, with four packets sent on each of 20 channels and three packets sent on each of 5 channels. For the channels sending four packets, the total on time is 0.389 seconds, which is less than the 0.4 second occupancy requirement.

Configuration(s)

The meters to be tested are installed in meter sockets appropriate for measuring electricity consumption. The following standard meter forms have been provided for test:

Meter Form	Test Voltage
Singlephase REX meter (Form 2S provided)	120 and 240Vac
Singlephase REX meter with internal service disconnect switch (Form 2S provided)	120 and 240Vac
Form 12S REX meter	120 Vac
Form 12S REX meter with internal service disconnect switch	120 Vac

All units have an internal antenna that is soldered directly to the printed circuit board. There are no other antenna options to be tested. As shown in Figure 9, the printed circuit board assembly is connected to line voltage (120 or 240V ac) and to the output of a current transformer. There are no other cables or wires connected to the REX meter.



Figure 11 – Picture of a REX meter in an electrical socket



Figure 12: REX Meter without Outer Cover and Inner Housing Removed

Operating Conditions

As stated in the previous section, the nominal line voltage seen by the REX meters to be tested are:

Meter Form	Test Voltage
Singlephase REX meter (Form 2S provided)	120 and 240Vac
Singlephase REX meter with internal service disconnect switch (Form 2S provided)	120 and 240Vac
Form 12S REX meter	120 Vac
Form 12S REX meter with internal service disconnect switch	120 Vac

Firmware and Software

There is a 16-bit Hitachi 38024 microprocessor that controls the behavior of the REX meter. The firmware revision to be tested will be released as firmware version 4.0. A software program titled "Meter Explorer" will be used to exercise the REX meter and place the meter in various modes of operation required to test that the meters adhere to the FCC guidelines. Elster Electricity will provide the test lab with a laptop pc with the software and the interface hardware required to communicate to the REX meter.

Mode(s)

Refer to Section 0.

Testing the REX Meter

Required Equipment

The following equipment is required to communicate to the REX Meter to change the operating mode for test purposes:

1. A pc with a Windows NT or Windows 2000 operating system.
2. An Elster Electricity software program titled "MeterExplorer". This software tool can be used to place the REX Meter into the various test modes. The software on a CD or a laptop computer with the software loaded will be provided to the test lab. Version 3.0.9 or higher of MeterExplorer is required.
3. An optical probe and associated optical probe power supply.

Elster Electricity will provide the test lab with a laptop pc with the optical probe and power supply. The description of the test setup has already been done on this laptop, and the reader of this document can skip to Section 0.

Test Setup

To communicate to the REX Meter, the optical probe must be plugged into a serial port on the pc and must also be plugged into the optical probe power supply. The optical probe is then hung on the optical hanger on the inner housing of the REX Meter. Note that the outer cover of the REX Meter must be removed to optically communicate to the REX Meter.

MeterExplorer Setup

By default, MeterExplorer is installed to the following directory:

C:\Program Files\Elster\MeterTools\

Assuming the default directory is not changed, the following step must be followed to allow MeterExplorer access to the REX Meter definition file:

- Copy the files titled “REX_METER_4_0.MD” and “REX_NODE_2_2.MD” to the following folder: C:\Program Files\Elster\MeterTools\MD\REX\

Note that the 4_0 suffix on the end of the file names indicate the firmware release. The firmware release and the file names may change accordingly.

Running MeterExplorer

From the Start menu, open MeterExplorer as follows:

Start ► Programs ► MeterTools ► MeterExplorer

MeterExplorer Properties

At the top of the MeterExplorer window, there are 3 drop down menus that allow selection of the meter type, communication medium, and the communication protocol. For the REX Meter, these drop downs must be set to the following:

- REX.REX_METER_4_0 (equivalent MD file is REX.REX_METER_251_2)
- OPTICAL_PROBE
- REX_OPTICAL

The MeterExplorer GUI configured for the REX Meter is shown in Figure 13.

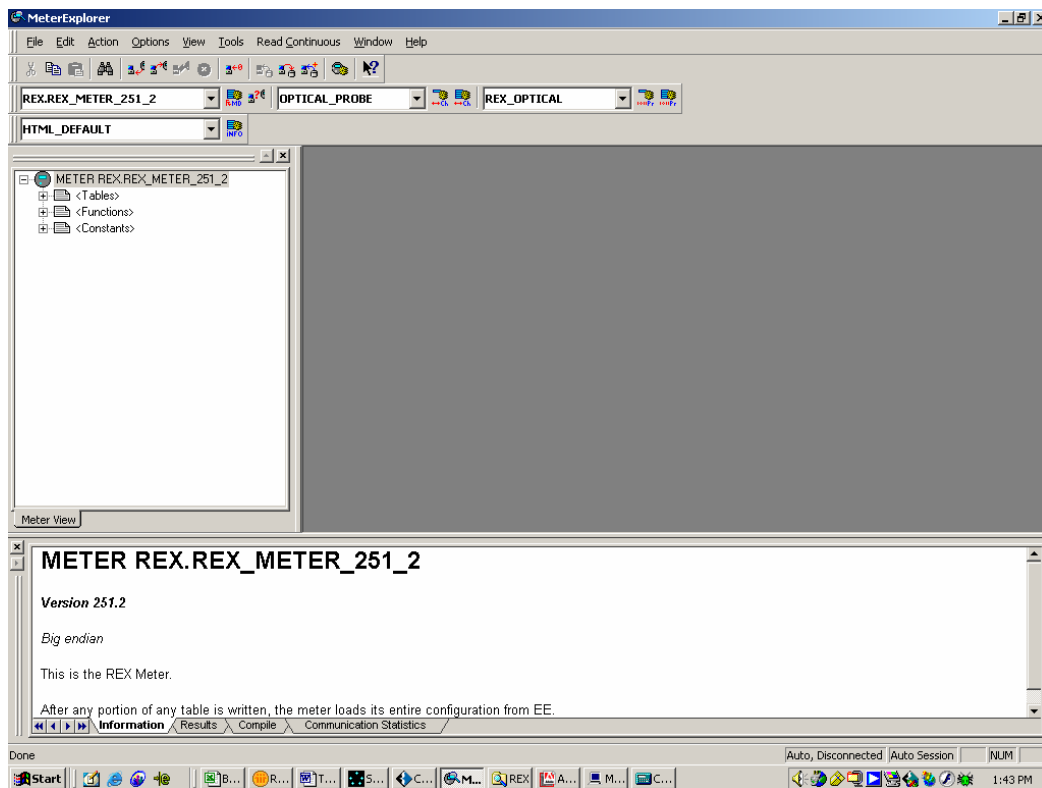

Figure 13: MeterExplorer GUI

To the immediate right of the communication medium (i.e. OPTICAL_PROBE) drop down menu is a tool button that allows the communication port and medium to be configured. By default, MeterExplorer uses Com Port 1 for communications. If you are using a different serial port on the pc, click the button and change the serial port to the port to which the optical probe is connected.

To the immediate right of the communication protocol (i.e. REX_OPTICAL) drop down menu is a tool button that allows the communication protocol to be configured. Click on this tool button to check that the following properties are set correctly:

- Session baud = 4800
- Password = 00000000
- The check box for Manufacturing Access must be checked.

The configuration is also shown in Figure 14.

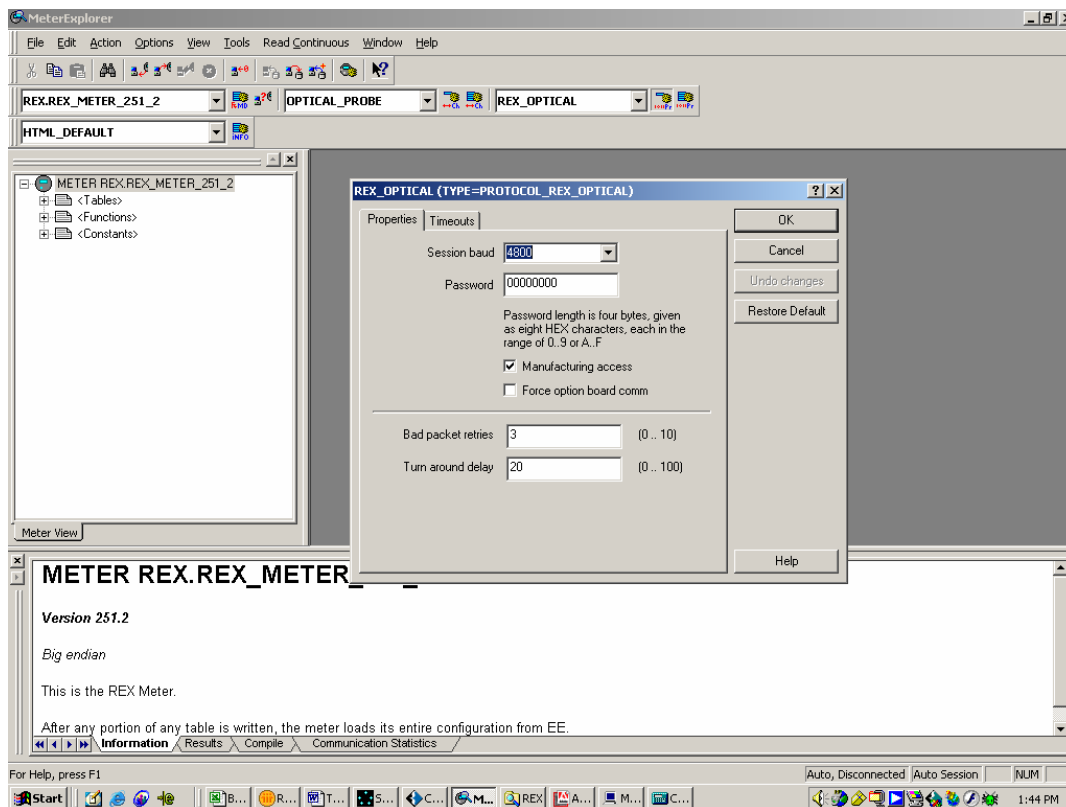

Figure 14: MeterExplorer - REX_OPTICAL Protocol Properties

Using MeterExplorer

MeterExplorer can be used to read or write tables to the meter and to force the meter to execute functions or commands. To read or write tables, expand the <Tables> item by clicking on the + box and then select the desired table by highlighting the table in the table list in the left-hand window. The table then can be accessed one of two ways:

1. From the main menu: **Action ▶ Read** or **Action ▶ Write**

OR

2. Right click the mouse while it is over the highlighted table and click the right mouse button. From the pop-up menu, select **Read** or **Write**

To execute a function, expand the <Functions> item by clicking on the + box and then select the desired function by highlighting the function in the function list in the left-hand window. The function can then be executed one of two ways:

1. From the main menu: **Action ▶ Execute Function(s)**

OR

2. Right click the mouse while it is over the highlighted function and click the right mouse button. From the pop-up menu, select **Execute Function(s)**

Description of Test Modes in the REX Meter

The REX Meter supports the following test modes of operation to facilitate FCC and manufacturing tests:

1. Test mode - Constant transmit, unmodulated data on a single channel
2. Test mode - Constant transmit – modulated data on a single channel
3. Test mode - Constant transmit – normal hopping, hopping between the 25 channels in the pseudo-random list of channels
4. Test mode - Constant receive mode on a single channel
5. Normal operation – Receive mode unless polled by another device.

The following sections describe the MeterExplorer software can be used to place the meter in the various modes.

For the test modes, the channel band (low or high) must be selected. Once configured it will be used for all tests on the band and then can be changed to the other band for further testing.

For all the tests, the radio channel is specified as a number from 0 to 31, with the center frequency of the channel calculated from the following formula:

$$\begin{aligned} \text{Low Band Center Frequency (MHz)} &= 902.4 + \text{Channel} * 0.4 \\ \text{High Band Center Frequency (MHz)} &= 915.2 + \text{Channel} * 0.4 \end{aligned}$$

For example, channel 0 is:

$$\begin{aligned} \text{Low Band Center Frequency (MHz)} &= 902.4 + 0 * 0.4 = 902.4 \text{ MHz} \\ \text{High Band Center Frequency (MHz)} &= 915.2 + 0 * 0.4 = 915.2 \text{ MHz} \end{aligned}$$

and channel 31 is:

$$\text{Center Frequency} = 902.4 + 31 * 0.4 \text{ (MHz)} = 914.8 \text{ MHz}$$

$$\begin{aligned} \text{Low Band Center Frequency (MHz)} &= 902.4 + 31 * 0.4 = 914.8 \text{ MHz} \\ \text{High Band Center Frequency (MHz)} &= 915.2 + 31 * 0.4 = 927.6 \text{ MHz} \end{aligned}$$

Constant Transmit Modes Using MF_041_RADIO_TEST

The Radio Test function allows a test engineer to place the REX Meter into a constant transmit mode on a specific frequency. There are function parameters that allow the mode and the channel to be selected by the engineer.

To change the parameters, highlight MF_041_RADIO_TEST in the functions items on the left of the screen. After the parameters are set in the right-hand window, highlight MF_041_RADIO_TEST, right click on the mouse to bring up the pop-up menu, and select **Execute Function(s)**.

The constant transmit mode is disabled when the REX Meter is power cycled or when the function is executed again with:

MF_041_RADIO_TEST.REQUEST.TEST_SELECT.TRANSMIT_CONTINUOUSLY = 0 {Disabled}

Constant Transmit – Unmodulated Data

MF_041_RADIO_TEST.REQUEST.TEST_SELECT.TRANSMIT_CONTINUOUSLY = 1 {Continuous, Unmodulated}

MF_041_RADIO_TEST.REQUEST.TEST_SELECT.DATA_BIT_TO_TRANSMIT = 0 or 1 (selects low or high deviation)

MF_041_RADIO_TEST.REQUEST.TEST_SELECT.RESERVED = 0

MF_041_RADIO_TEST.REQUEST.CHANNEL = 0 – 31 (selects the channel)

Constant Transmit – Modulated Data

MF_041_RADIO_TEST.REQUEST.TEST_SELECT.TRANSMIT_CONTINUOUSLY = 2 {Continuous, Modulated}

MF_041_RADIO_TEST.REQUEST.TEST_SELECT.DATA_BIT_TO_TRANSMIT = 0

MF_041_RADIO_TEST.REQUEST.TEST_SELECT.RESERVED = 0

MF_041_RADIO_TEST.REQUEST.CHANNEL = 0 – 31 (selects the channel)

Test Modes Controlled by Parameters in MT-224

MT-224 is a configuration table that controls the operation of the 900 MHz radio. The table allows for the REX Meter to be placed in test modes. To change the contents of MT-224, first read the table by doing the following:

1. Under the list of tables in the REX Meter, highlight MT_224_LAN_CONFIGURATION.
2. With the table selected, right click on the mouse to bring up a pop-up menu and select **Read**
3. After reading the table, change the parameters necessary for the test (refer to Sections 0 and 0).
4. With the table selected, right click on the mouse to bring up a menu and select **Write**

To take the unit out of test mode, the table must be written again with the parameters returned to the normal state. This can be done by reversing the procedure listed above or by following the procedures listed in Section 0 to put the unit back into the normal operating mode.

Band Configuration

The band can be selected as low band (902.8 – 914.8 MHz) or high band (915.6 – 927.6 MHz). Set the band by changing the following field in MT-224:

```
MT_224_LAN_CONFIGURATION.RADIO_CONFIG.CONF.USE_HIGH_CHANNEL_BAND = 1 {True} HIGH BAND or  
MT_224_LAN_CONFIGURATION.RADIO_CONFIG.CONF.USE_HIGH_CHANNEL_BAND = 0 {False} LOW BAND
```

Constant Transmit – Channel Hopping

When placed in this mode, the meter will continually transmit packets, with each packet being approximately 97.3 msec in duration and an 8 – 16 msec off time between packets. Each packet is sent on the next channel in the pseudo-random list of channels (refer to Section 0).

To place the REX Meter in this mode, the following MT-224 parameters must be changed from the normal MT-224 configuration:

```
MT_224_LAN_CONFIGURATION.RADIO_CONFIG.FLAGS.IS_IN_TEST_MODE = 1 {True}  
MT_224_LAN_CONFIGURATION.RADIO_CONFIG.FLAGS.IS_SENDER = 1 {True}  
MT_224_LAN_CONFIGURATION.RADIO_TEST_MODE_PARAMETERS.NUM_PACKETS = 65,000  
MT_224_LAN_CONFIGURATION.RADIO_TEST_MODE_PARAMETERS.SEND_DELAY = 0  
MT_224_LAN_CONFIGURATION.RADIO_TEST_MODE_PARAMETERS.TEST_PACKET.PACKET_LENGTH = 70
```

WARNING: Once MT-224 is set as shown above, the REX Meter will stay in this constant transmit mode until MT-224 is written with the parameters set for normal operation. After the test is completed, make sure to reverse the procedure to put the REX Meter back into the normal operating mode. To do this, the MT-224 parameters must be changed back to their default values:

```
MT_224_LAN_CONFIGURATION.RADIO_CONFIG.FLAGS.IS_IN_TEST_MODE = 0 {False}  
MT_224_LAN_CONFIGURATION.RADIO_CONFIG.FLAGS.IS_SENDER = 0 {False}  
MT_224_LAN_CONFIGURATION.RADIO_TEST_MODE_PARAMETERS.NUM_PACKETS = 0  
MT_224_LAN_CONFIGURATION.RADIO_TEST_MODE_PARAMETERS.SEND_DELAY = 0  
MT_224_LAN_CONFIGURATION.RADIO_TEST_MODE_PARAMETERS.TEST_PACKET.PACKET_LENGTH = 0
```

Constant Receive Mode

In test mode, the REX Meter can be configured to receive only on a specified channel. To place the REX Meter in this mode, the following MT-224 parameters must be changed from the normal MT-224 configuration:

```
MT_224_LAN_CONFIGURATION.RADIO_CONFIG.FLAGS.IS_IN_TEST_MODE = 1 {True}  
MT_224_LAN_CONFIGURATION.RADIO_CONFIG.FLAGS.IS_SENDER = 0 {False}
```

MT_224_LAN_CONFIGURATION.RADIO_CONFIG.FLAGS.USE_CHANNEL_LIST = 1 {True}

MT_224_LAN_CONFIGURATION.RADIO_TEST_MODE_PARAMETERS.CHANNEL_LIST[0] = 0 – 31 (selects the channel)

WARNING: Once MT-224 is set as shown above, the REX Meter will stay in this mode of operation until MT-224 is written with the parameters set for normal operation. After the test is completed, make sure to reverse the procedure to put the REX Meter back into a normal mode of operation. To do this, the MT-224 parameters must be changed back to their default values:

MT_224_LAN_CONFIGURATION.RADIO_CONFIG.FLAGS.IS_IN_TEST_MODE = 0 {False}

MT_224_LAN_CONFIGURATION.RADIO_CONFIG.FLAGS.IS_SENDER = 0 {False}

MT_224_LAN_CONFIGURATION.RADIO_CONFIG.FLAGS.USE_CHANNEL_LIST = 0 {False}

MT_224_LAN_CONFIGURATION.RADIO_TEST_MODE_PARAMETERS.NUM_PACKETS = 0

MT_224_LAN_CONFIGURATION.RADIO_TEST_MODE_PARAMETERS.SEND_DELAY = 0

MT_224_LAN_CONFIGURATION.RADIO_TEST_MODE_PARAMETERS.TEST_PACKET.PACKET_LENGTH = 0

Normal Operation

In the normal operating mode, the REX Meter will only transmit if there is an exception condition to be sent or if polled by another device. When not transmitting, the REX Meter is in receive mode scanning the 25 channels for a valid packet in an attempt to synchronize to another device.

To restore the REX Meter to the normal operating condition, use MeterExplorer to write the MT-224 base configuration to the meter. This is done as follows:

1. Under the list of tables in the REX Meter, highlight MT_224_LAN_CONFIGURATION.
2. With the table selected, right click on the mouse to bring up a menu and select **Read**
3. With the table selected, right click on the mouse to bring up a menu and select:
Load From File
4. At the prompt, select and open the file named: “RexMeterBaseConfig_251_2.mtd”
5. Under the list of tables in the REX Meter, highlight MT_224_LAN_CONFIGURATION.
6. With the table selected, right click on the mouse to bring up a menu and select **Write**

The read followed by the write verifies that the information unique to a particular meter is maintained.

Performance Criteria (Required for Immunity Testing Only)

Immunity testing on the REX meters is not required and this section is therefore not applicable.

Power Requirements

The REX meters are powered by connecting 120Vac or 240Vac to the blades on the back of the meter. Power is typically brought to the meter blades via a meter socket, and Elster Electricity has provided these sockets to the test lab.

Table 5 - Power Requirements

EUT	Input Voltage	Input Frequency	Input Current (rated)	1 ϕ , 3 ϕ , or DC	Plug Type
Form 2S REX Meter	120 to 240Vac	60 Hz	200A	1 ϕ	meter socket
Form 2S REX Meter with service disconnect option board and switch	120 to 240Vac	60 Hz	200A	1 ϕ	meter socket
Form 12S REX Meter	120Vac	60 Hz	200A	2 ϕ	meter socket
Form 12S REX Meter with service disconnect option board and switch	120Vac	60 Hz	200A	2 ϕ	meter socket

Oscillator / Microprocessor Frequencies

This section lists all oscillator frequencies used in the EUT. This is required for immunity testing (each frequency is dwelled upon during Radiated Immunity) and extremely helpful for mitigation during Radiated Emissions.

The 900 MHz radio in the REX Meter is a frequency-hopping spread spectrum radio. The receiver is a single conversion, super-heterodyne receiver, with a 10.7 MHz IF. The receiver local oscillator is 10.7 MHz below the channel frequency.

Table 6 - Oscillator Frequency List

Frequency (MHz)	Description of Use
20.48 MHz	Crystal Oscillator for processor clock and synthesizer reference.
10.7 MHz	Receiver IF (Receiver is a single-conversion, super-heterodyne receiver, with a 10.7 MHz IF)
4.096 MHz	Internal clock of the metering chip (U12) with internal divide by 5 and external 20.48 MHz input.

Equivalent Models

Elster Electricity has provided samples of the various meters to be tested as listed in Section 0. The following table lists equivalent models. There may be other singlephase or Form 12S styles that are supported by Elster in the future, but the changes would be based on customer configuration preferences and the styles would be equivalent to the styles provided for testing. Style combinations other than those listed are possible, but would be equivalent from a PCBA and radio perspective.

Table 7 - Models Equivalent to EUT

Model Number (Elster Style Number)	Reason for Equivalence
ZCA1H000?00 ZCA19000?00 ZCA29000?00 ZCA39000?00 ZCC29000?00 ZCCWB000?00	The meter provided for testing is a Form 2S singlephase meter, style ZCC39000000. These meters are also singlephase meters. The H in the field 5 calls out the PCBA with the dual SAW filters 902-928 MHz in the receive path. Field 9 is a “?” because it can be different values based on a mechanical part used to block the optical port to prevent optical communications. Field 9 does not impact the radio or change the PCBA.
ZCCW9000?00 ZCC3B000?00 ZCC19000?00 ZCC39000?00 ZCC49000?00 ZCCY9000?00	The meter provided for testing is ZCC39000000, which is a Form 2S, 200A meter with voltage disconnect link. All of the equivalent styles are also Form 2S meters. “CW9” is the same except it does not have a voltage disconnect link. “C3B” is the same except it has an option board header populated on the main PCBA. “C49” is the same except it is rated for 320A operation.
ZCCT9A00?00 ZCC99A00?00 ZCA19A00?00 ZCC19A00?00 ZCA99A00?00 ZCA1HA00?00	All are singlephase meters with service disconnect styles. The style provided for testing is ZCC99A00000, which is a Form 2S 160A meter with voltage test link. The “CT” style does not have a voltage test link. The “A1” is a Form 1S meter rated for Class 100 operation. The “A9” style is a Form 1S meter rated for Class 160 operation. The H in the field 5 calls out the PCBA with the dual SAW filters 902-928 MHz in the receive path.
ZC5W9000?00 ZC519000?00 ZC539000?00 ZC549000?00	All are 12S styles. The meter provided for testing is ZC539000000. “5W9” is the same as “539” except “5W9” does not have a voltage test link. “519” is the same except the nameplate is marked for Class 100 operation instead of Class 200 operation. “549” is the same meter, except calibrated for Class 320A operation.
ZC519A00?00 ZC599A00?00	Both are 12S with service disconnect styles. The style provided for testing is ZC599A00000. The ZC519A00000 is the same meter, except the nameplate is marked as a Class 100 (max. current). Everything in the meter is otherwise the same.

Methods of Determining Equivalence

Either of the following methods can be used for including a list of equivalent models into the laboratory test report. Elster Electricity will provide a letter of attestation stating that the model listed above is equivalent to the model tested.

Manufacturer's Letter of Attestation

The manufacturer can provide a Letter of Attestation to the laboratory stating that the model(s) listed are equivalent to the one(s) tested. The laboratory will include this list in its final test report with the following statement:

The manufacturer has provided this list of equivalent models and has been included in this report for the convenience of the customer. The laboratory has *not* performed an evaluation of these models and makes no statement regarding the validity of the list.

Laboratory Evaluation

The manufacturer can present the laboratory with a list of equivalent model(s) and the reason(s) why each model is equivalent to the one(s) tested. The laboratory will evaluate each model on the list and determine whether it is equivalent or not. Model(s) determined to be equivalent can be listed in the report with the following statement:

The laboratory has performed an evaluation of this list of equivalent models and states that the test data contained within this report applies to the compliance of these models with the standards tested to. This statement is based on a test sample.