



Product Guide
PG42-1017A

A3 ALPHA[®] Meter/Node (ILC2)

© 2008 by Elster. All rights are reserved.

No part of this software or documentation may be reproduced, transmitted, processed or recorded by any means or form, electronic, mechanical, photographic or otherwise, translated to another language, or be released to any third party without the express written consent of Elster.

Printed in the United States of America.

ALPHA, ALPHA Plus, EnergyAxis, and REX are registered trademarks; and Metercat, AlphaPlus, and REX2 are trademarks of Elster.

Other product and company names mentioned herein may be the trademarks and/or registered trademarks of their respective owners.

DISCLAIMER OF WARRANTIES AND LIMITATIONS OF LIABILITY

There are no understandings, agreements, representations, or warranties either expressed or implied, including warranties of merchantability or fitness for a particular purpose, other than those specifically set out by any existing contract between the parties. Any such contract states the entire obligation of the seller. The contents of this document shall not become part of or modify any prior existing agreement, commitment, or relationship.

The information, recommendations, descriptions, and safety notices in this document are based on Elster experience and judgment with respect to operation and maintenance of the described product. This information should not be considered as all-inclusive or covering all contingencies. If further information is required, Elster should be consulted.

No warranties, either expressed or implied, including warranties of fitness for a particular purpose or merchantability, or warranties arising from the course of dealing or usage of trade, are made regarding the information, recommendations, descriptions, warnings, and cautions contained herein.

In no event will Elster be responsible to the user in contract, in tort (including negligence), strict liability or otherwise for any special, indirect, incidental, or consequential damage or loss whatsoever, including but not limited to: damage or loss of use of equipment, cost of capital, loss of profits or revenues, or claims against the user by its customers resulting from the use of the information, recommendations, descriptions, and safety notices contained herein.

Contents

General Description 1

A3 ALPHA Meter Circuit Board 1

 Metercat Programming Note 3

Metering Software and System 4

 Metercat 4

 EnergyAxis Metering Automation Server 4

Operation of the A3 ALPHA Meter with ILC2 Option Board 4

 Billing Date 4

 TOU Schedules 5

 Season Changes 5

 Power Failure and Restoration 5

 ILC2 Option Board Configuration 5

 Short data format 5

 Long data format 6

Reading the A3 ALPHA Meter 6

Changing an A3 ALPHA Meter 6

Display List Items 7

ILC2 Option Board Error Codes 7

 No error 7

 Table CRC error 8

 General configuration error 8

 Shared memory error 8

 Power fail data save error 8

ILC2 Option Board Status Codes 8

 No status 8

 Node is registered 8

 Demand reset scheduled 8

ILC2 Option Board Information 9

 LAN ID 1 9

 LAN ID 2 9

 Utility ID 9

 Network registration status 9

FCC and Industry Canada Compliance 9

 Compliance Statement (Part 15.19) 9

 Warning (Part 15.21) 10

 RF Radiation Safety Guidelines per Part 2 of FCC Rules and Regulations 10

 User Information (Part 15.105) 10

 Industry Canada Statement 10

 Collocation Statement 10

Technical Specifications 11

 Operating Ranges 11

General Description

The A3 ALPHA meter can be used as a component of the EnergyAxis® System where remote communications in polyphase and advanced single phase metering is desired for commercial and industrial accounts. The A3 ALPHA meter can be equipped with an option board that communicates to the network via the 2-way, 900 MHz, radio frequency LAN. This option essentially allows the A3 ALPHA meter to be a metering node within the EnergyAxis automated metering network. The primary task of the ILC2 option board is to communicate within the local area network (LAN) and process billing data from A3 ALPHA meters. The A3 ALPHA meter performs its programmed metering tasks but now has remote communications features within the EnergyAxis network.

In addition with the other communication functions as part of the EnergyAxis System, the A3 ALPHA meter/node can return metering data in one of the following formats:

- The *short data format* provides kWh consumption data, three current maximum demand quantities, one channel of load profiling, and basic status information.
- The *long data format* provides two metered quantities, two maximum or coincident demands, two channels of load profiling, and extensive status information.

The format is selected at the time of ordering and is configured at the factory. The short data format can be used when only one metered quantity or one load profiling channel is needed. The long data format can be used if you need two metered quantities, two load profiling channels, or other data not provided by the short data format. The long data format requires more communication time and more storage in the collector. For more information about the two data formats, including the status information they return, see “ILC2 Option Board Configuration” on page 5.

A3 ALPHA Meter Circuit Board

The A3 ALPHA meter builds upon the strengths of the existing ALPHA meter designs. Like its predecessors, the A3 ALPHA meter uses Elster Electricity’s patented digital measurement techniques that offer high accuracy, repeatability, and low ownership costs. In support of open architecture standards, the A3 ALPHA meter is the first Elster Electricity meter to fully support ANSI C12.18, C12.19, and C12.21 standards.

To function as a node in the EnergyAxis System, an A3 ALPHA meter requires the following option boards:

- internal interface board to support the mounting of the ILC2 option board
- the ILC2 option board

The interface board connects to the A3 ALPHA meter using the 20-pin header (J4) on the meter circuit board as shown in Figure 1. The ILC2 option board connects to the interface board using the 20-pin header (J5) as shown in A3 ALPHA meter electronic assembly.

The antenna for the ILC2 option board mounts directly onto the electronic housing (see Figure 2) and fits completely under the cover of the A3 ALPHA meter.

A thin shield between the interface board and the main meter circuit board provides additional isolation between the option boards and the high voltage components of the A3 ALPHA meter. The unit should not be operated without this shield installed.

Figure 1. A3 ALPHA meter electronic assembly

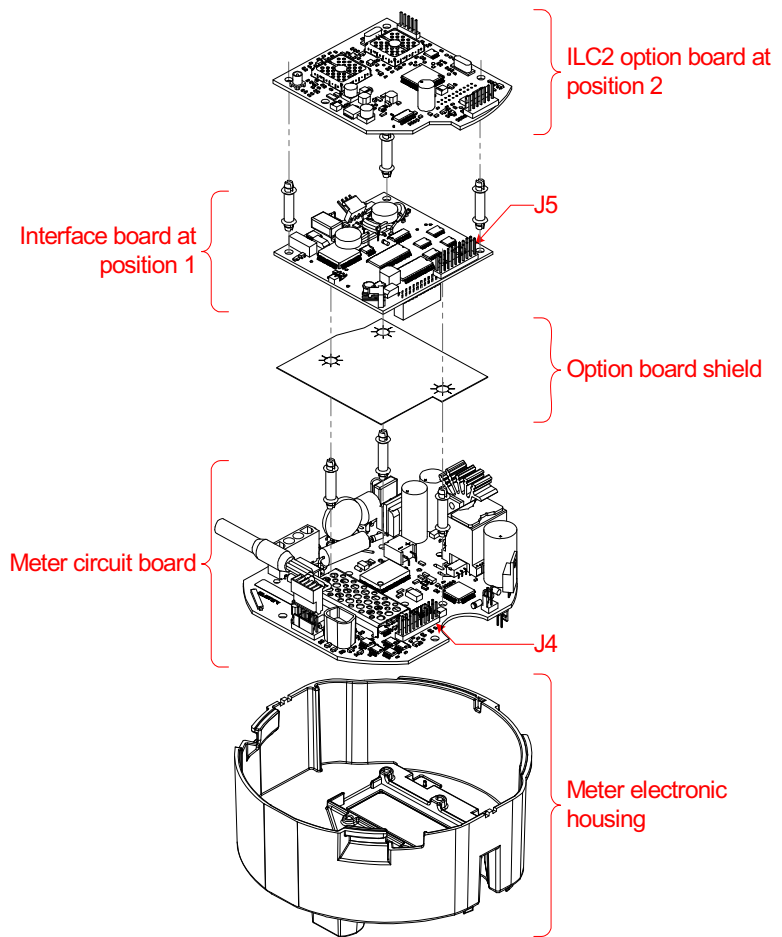
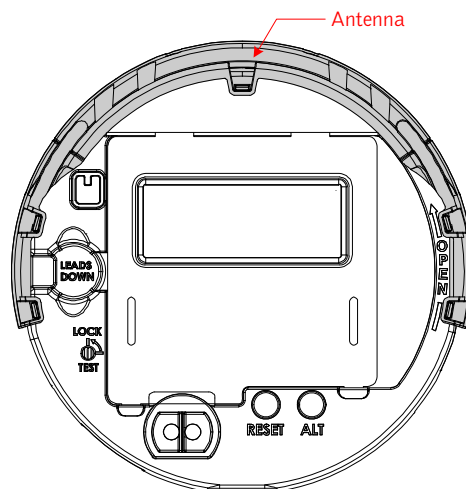

Figure 2. A3 ALPHA meter electronic housing with antenna



Metercat Programming Note

To have the A3 ALPHA meter function properly as a node in the EnergyAxis System, it is important that the meter be programmed correctly using Metercat™. Be sure to understand the following restrictions:

Component	Description
Quantities	<ul style="list-style-type: none"> ■ Short data format: The ILC2 will return the first kWh quantity configured in the meter. ■ Long data format: The ILC2 will return the first two quantities configured in the meter. It will also return the first two coincident demands configured in the meter.
Interval Data Configuration	<ul style="list-style-type: none"> ■ Quantities to Record: The first two quantities will be the quantities profiled by the node. Selecting any net quantity will result in an ILC2 configuration error. ■ Interval Length: If using <i>short data format</i>, select only 15, 30, or 60 minutes. If using <i>long data format</i>, select any value evenly divisible into 60 (that is 1, 2, 3, 4, 5, 6, 10, 12, 15, 20, 30, or 60). Selecting any other interval length will return interval data, but with an unknown interval length reported to MAS.
Display	<p>When operating as a node, the following items (located in the LAN Items category) are available for display:</p> <ul style="list-style-type: none"> ■ ILC errors ■ ILC status ■ LAN ID ■ utility ID ■ LAN registration information
Demand	<p>Interval (minutes): If using short format, Elster recommends that you select 15, 30, or 60 minutes. If using long format, you may select any value evenly divisible into 60. Selecting any other value will prevent the actual demand interval length from being reported in the data. That is, the actual data will be reported without specifying the demand interval length.</p>
Special Dates	<p>When instructing the meter to perform a demand reset for either recurring or nonrecurring dates, any demand reset date will be cleared by the ILC2 option board (except those assigned to a season change date). Within the EnergyAxis System, billing demand resets are controlled by the system through the collector.</p>
Remote ¹	<p>Configure port 1 usage for "Direct Connect" and port 2 usage for "Disabled." Port 1 direct connect should be set to 9600 bps.</p>

¹ If you do not see the Remote tab, select Remote as a program option in the Properties tab of your program.

Note. If the remote definition is not programmed into the meter, the ILC2 will not be able to return any meter reads to MAS.

The other options can be set as desired. For more information on using Metercat, see the Metercat user guide (TM42-2203K or later) or the online Help.

Metering Software and System

Metercat

The A3 ALPHA meter operating as a node in the EnergyAxis System requires Elster Electricity Metercat support software release 1.8 or later. Metercat offers the following features:

- program development to create user-defined configuration data
- meter programming to send user-defined configuration data or commands to the meter
- meter reading to receive data that has been stored by the meter
- diagnostic read including ILC2 option board and LAN status

EnergyAxis Metering Automation Server

The EnergyAxis Metering Automation Server (MAS) reads meters over telephone or wireless networks. Using MAS, meter readings can be scheduled or performed on-request from the browser-based user interface. MAS allows all billing data to be read from the meter; this includes data from each A3 ALPHA meter registered with the EnergyAxis local area collector. Billing data from the A3 ALPHA meter includes consumption, demand, time-of-use registers as well as meter status flags. The A3 ALPHA meter data can be read from the stored data in the collector or on-request by using MAS to communicate through the collector to the individual A3 ALPHA meter.

Data exchange between MAS and other utility systems is performed using an open XML schema, AMR Data Exchange Format (AMRDEF), so that interfaces with billing systems and other enterprise systems can be easily implemented. MAS also comes with the JSlinger module, a powerful driver for file transfer protocol (FTP) that can transform, compress and encrypt data files prior to sending them to trusted IP addresses across the Internet.

Operation of the A3 ALPHA Meter with ILC2 Option Board

The A3 ALPHA meter and the ILC2 option board communicate within the EnergyAxis system 900 MHz radio frequency network. The primary task of the ILC2 option board is to communicate with the LAN and to provide meter readings from the A3 ALPHA meter and pass on commands to the A3 ALPHA meter. While the time base within the A3 ALPHA meter is maintained by its super capacitor and a battery, time is adjusted automatically by the network when required.

Billing Date

The EnergyAxis System handles the billing dates for the registered A3 ALPHA meters. MAS assigns each meter to one of 30 possible billing dates, and then MAS transmits the billing dates to the meters' respective collectors. On the billing date, the collector schedules the meter to perform a demand reset at the next midnight crossing.

At midnight, the ILC2 option board copies the A3 ALPHA meter's billing data to a separate memory location. A demand reset is then performed immediately thereafter. During the next reading of all its registered meters, the collector retrieves and stores the copy of the billing data. Once the billing data is stored in the collector, it can be retrieved by MAS at the next read of the collector.

This feature allows individual meters to be identified to a specific billing date that conforms to the consumer's request or the utility's business process. Neighboring meters can have individual billing dates and are not forced to be read on the same day. Changes to the billing date are handled through a schedule change in MAS.

TOU Schedules

The A3 ALPHA meter can be programmed using Metercat to operate on a TOU program. Each program includes a TOU schedule and display list. Each TOU schedule for the A3 ALPHA meter consists of weekday, weekend, and two special day types (that is, holidays). The display list controls the values that are shown on the A3 ALPHA meter LCD. See the *A3 ALPHA Meter Technical Manual* (TM42-2190) for information on the values that can be displayed on the A3 ALPHA meter LCD.

Season Changes

Season changes for the A3 ALPHA meter are controlled by the calendar in the A3 ALPHA meter.

Power Failure and Restoration

When there is a power failure, the A3 ALPHA meter initiates a shutdown and stores the A3 ALPHA meter billing data and status information in EEPROM. All information stored in the ILC2 option board is stored in battery-backed RAM. The A3 ALPHA meter's real-time clock and the data stored in the ILC2 option board are maintained by the super capacitor and battery in the A3 ALPHA meter during a power failure. If both the super capacitor and battery fail, all RAM in the meter and in the ILC2 will be lost.

Upon subsequent power restoration, an error code is generated for both the A3 ALPHA meter and the ILC2 option board.

- For information on A3 ALPHA meter error codes, see the *A3 ALPHA Meter Technical Manual* (TM42-2190).
- For information on ILC2 option board error codes, see "ILC2 Option Board Error Codes" on page 7.

ILC2 Option Board Configuration

At the time of ordering, the node can be configured to report register data in one of two ways:

- short data format
- long data format

Short data format. The short data format returns the first kWh consumption data configured in the meter, three current maximum demand quantities, identification for 1 channel of load profiling, and 1 channel of load profiling to the collector.

- The first demand quantity can be assigned to the maximum demand of any of the four tiers or can be assigned to the total demand.

- The second demand quantity can be assigned to any of the four rates.
- The third demand quantity can be assigned to any of the four rates.

In addition, the short data format returns the following information:

- per phase voltages
- A3 ALPHA meter configuration information
- the presence of meter error or warning codes
- number of demand resets
- number of outages

Long data format. The long data format returns the first two metered quantities configured in the meter, maximum demand or cumulative maximum demand for all rates, identification for 2 channels of load profiling, and 2 channels of load profiling to the collector.

In addition, the long data format returns the following information:

- per phase voltages
- A3 ALPHA meter configuration
- specific meter error or warning code
- number of demand resets
- number of outages

Reading the A3 ALPHA Meter

The A3 ALPHA meter can be read in the following ways:

- visually using the LCD
- optically using Metercat support software
- remotely via the EnergyAxis system 900 MHz network

For more details on the information that can be viewed on the LCD, see “Display List Items” on page 7.

For more details on reading the A3 ALPHA meter optically, see the Metercat documentation and online Help.

For more details on reading the A3 ALPHA meter remotely, see the MAS documentation and online Help.

Changing an A3 ALPHA Meter

▲ WARNING

Use authorized utility procedures to remove metering equipment. Dangerous voltages are present. Equipment damage, personal injury, or death can result if safety procedures are not followed.

If the A3 ALPHA meter must be taken out of service (because of an error condition, the ILC2 option board fails, etc.), the A3 ALPHA meter can be replaced with another A3 ALPHA meter. See the change-out information in the *A3 ALPHA Meter Technical Manual* (TM32-2190)

Display List Items

The A3 ALPHA meter display is divided into different regions as shown in Figure 3. See Chapter 3, “Operating Instructions,” in the A3 ALPHA Meter Technical Manual (TM42-2190) for more detailed descriptions of the LCD and its display regions.

Figure 3. A3 ALPHA meter LCD

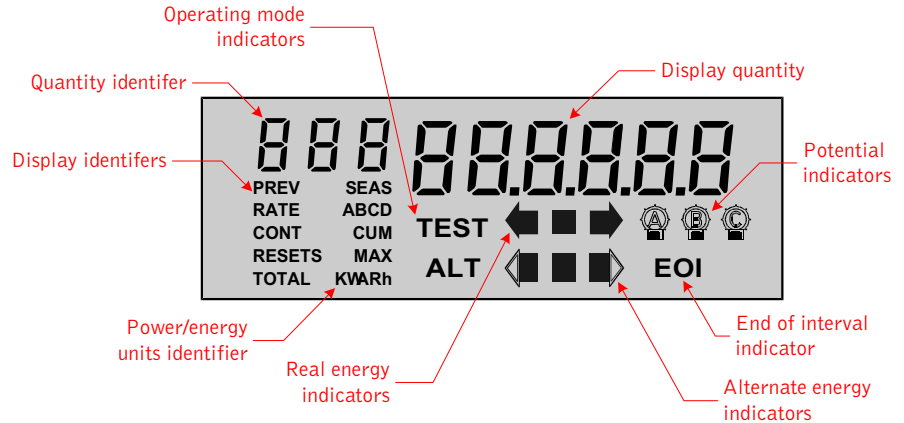

The display list for all displayable items, including the items relating to the ILC2 option board, can be programmed using Metercat meter support software.

ILC2 Option Board Error Codes

Unlike standard A3 ALPHA meter error codes, ILC2 option board error codes must be programmed as a displayable item in the A3 ALPHA meter display list using Metercat support software; otherwise, the meter LCD will not display any indication that a condition exists that affects the ILC2 option board's operation. Error conditions and codes identify the ILC2 option board error conditions and the associated display quantity value. The quantity identifier is the same for all ILC2 option board error codes and can be programmed to be any numeric character (represented by **i** in Table 1).

Table 1. Error conditions and codes

Condition	Quantity identifier	Display quantity value
No error	iii	000000
Table CRC error	iii	000100
Configuration error	iii	001000
Shared memory error	iii	010000
Power fail data save error	iii	100000

Error codes may be displayed in combination (for example, **iii 100100**), indicating that more than one error condition has been detected.

No error. This code is displayed when no error condition exists in the ILC2 option board. Since ILC2 option board error codes must be programmed as display items, this code is used when no error condition is present in the ILC2 option board.

Table CRC error. This code indicates an error in the ILC2 option board's programming. Contact Elster Electricity if this error code is displayed on the LCD.

General configuration error. This code indicates a problem with the ILC2 option board's configuration or program.

- If the node is programmed for the short data format, verify that the meter is programmed with at least one kWh quantity.
- If the meter is programmed for load profiling, this error code will be displayed if one of the first two quantities is programmed for a net quantity.

Contact Elster Electricity if this error code is displayed and there is no apparent programming issues.

Shared memory error. This code indicates a problem exists in the shared memory area. Contact Elster Electricity if this error code is displayed on the LCD.

Power fail data save error. This code indicates that the data saved in the ILC2 option board's nonvolatile memory during a power failure may be invalid. This error will be displayed when power is restored to the meter if a self check has discovered an error with the ILC2 option board's memory. Contact Elster Electricity if this error code continues to be displayed on the LCD.

ILC2 Option Board Status Codes

ILC2 status code must be programmed as a displayable item to appear on the A3 ALPHA meter LCD using Metercat support software. Unlike error codes, the status codes do not indicate a problem with the ILC2 option board. Status condition and code identifies the status condition and its associated display quantity value. The quantity identifier is the same for all ILC2 option board status codes and can be programmed to be any numeric character (represented by **i** in Table 2).

Table 2. Status conditions and codes

Condition	Quantity identifier	Display quantity value
No status	iii	000000
Node is registered	iii	000100
Demand reset scheduled	iii	000010

No status. This code is displayed when no status condition exists in the ILC2 option board. Since ILC2 option board error codes must be programmed as display items, this code is used when no status condition is present in the ILC2 option board.

Node is registered. This code indicates that the A3 ALPHA meter with the ILC2 option board is registered with a collector. See "Network registration status" on page 9 for more specific information about the registration information.

Demand reset scheduled. This code indicates that the meter has been scheduled to perform a demand reset at the next midnight crossing. This code is displayed when the node receives a command to perform a demand reset from the network. The code remains in the display until the next midnight crossing (the time at which the meter performs a demand reset). See the *A3 ALPHA Meter Technical Manual* for more information on demand resets.

ILC2 Option Board Information

ILC2 option board information can be displayed on the A3 ALPHA meter LCD. Information item and display format identifies all the items that are available for display. The quantity identifier must be a numeric character (represented by **i** in Table 3) and should be unique for each item that you want to display. Use Metercat meter support software to select the display items and their associated quantity identifier.

Table 3. Information item and display format

Display item	Quantity identifier	Display quantity value
LAN ID 1	iii	xxxx
LAN ID 2	iii	xxxxxx
Utility ID	iii	xxxxxx
Network registration status	iii	xxxxxx

LAN ID 1. This item displays the first 4 digits of the ILC2 option board LAN ID.

LAN ID 2. This item displays the last 6 digits of the ILC2 option board LAN ID.

Utility ID. This item displays the utility ID for the A3 ALPHA meter. The utility ID is the same for all meters that are part of the same network.

Network registration status. This item displays the following information about the A3 ALPHA meter (see Figure 4):

- the A3 ALPHA meter is registered with a collector
- the number of communication “hops” between the A3 ALPHA meter and the collector
- the last four digits of the collector’s LAN ID

Figure 4. Network registration status display

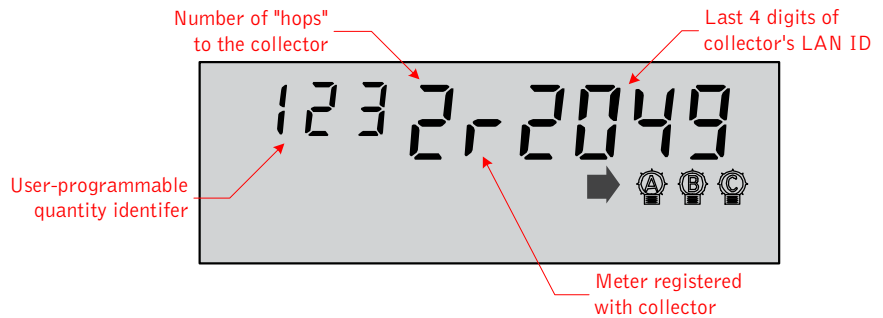

FCC and Industry Canada Compliance

Compliance Statement (Part 15.19)

This equipment complies with Part 15 of the FCC Rules and with RSS-210 of Industry Canada. Operation is subject to the following two conditions:

- This device may not cause harmful interference, and
- This device must accept any interference received, including interference that may cause undesired operation.

Warning (Part 15.21)

Changes or modifications not expressly approved by Elster Electricity, LLC could void the user's authority to operate the equipment.

RF Radiation Safety Guidelines per Part 2 of FCC Rules and Regulations

The meter should be installed in a location where there will be a separation greater than 20 cm (8 inches) from locations occupied by humans.

User Information (Part 15.105)

This equipment has been tested and found to comply with the limits for a Class B digital device, pursuant to part 15 of the FCC Rules. These limits are designed to provide reasonable protection against harmful interference in a residential installation. This equipment generates, uses and can radiate radio frequency energy and, if not installed and used in accordance with the instructions, may cause harmful interference to radio communications. However, there is no guarantee that interference will not occur in a particular installation. If this equipment does cause harmful interference to radio or television reception, the user is encouraged to try to correct the interference by one or more of the following measures:

- Reorient or relocate the receiving antenna.
- Move the receiving equipment farther away from the A3 ALPHA meter/collector.
- Consult the dealer or an experienced radio/TV technician for help.

Industry Canada Statement

The term "IC" before the certification/registration number only signifies that the Industry Canada technical specifications were met.

Collocation Statement

Collocation of simultaneously-transmitting (co-transmitting) antennas within 20 cm of each other in a final product is not allowed.

Technical Specifications

Appendix E, “Technical Specifications,” of the *A3 ALPHA Meter Technical Manual* (TM42-2190) lists the meter specifications for an A3 ALPHA meter. When the A3 ALPHA meter is operating as a node within the EnergyAxis system, the operating range for a Form 35S meter is different than the specifications listed in TM42-2190.

Operating Ranges

Voltage	Nameplate nominal range	Operating range
Form 35S	120 V to 240 V	96 V to 288 V
All other forms	120 V to 480 V	96 V to 528 V



Elster Electricity, LLC

Raleigh, North Carolina USA
+ 1 800 338 5251 (US Toll Free)
+ 1 919 212 4800 (US Main)
+ 1 905 634 4895 (Canada)
support@us.elster.com
www.elsterelectricity.com