

## **Certification Test Report**

**FCC ID: QZC-ILC24FI**

**FCC Rule Part: 15.247**

**ACS Report Number: 15-0013.W03.2C**

Manufacturer: Elster Solutions, LLC  
Model: ILC24FI

Test Begin Date: January 28, 2015  
Test End Date: January 29, 2015

Report Issue Date: March 31, 2015



FOR THE SCOPE OF ACCREDITATION UNDER LAB Code 200612-0

This report is not be used to claim certification, approval, or endorsement by NVLAP, NIST or any government agency.

Reviewed by:

A handwritten signature in black ink, appearing to read "Kirby Munroe", is positioned above the printed name.

**Kirby Munroe**  
**Director, Wireless Certifications**  
**ACS, Inc.**

This test report shall not be reproduced except in full. This report may be reproduced in part with prior written consent of ACS, Inc. The results contained in this report are representative of the sample(s) submitted for evaluation.

**This report contains 24 pages**

# TABLE OF CONTENTS

<b>1</b>	<b>GENERAL .....</b>	<b>3</b>
1.1	PURPOSE.....	3
1.2	PRODUCT DESCRIPTION .....	3
1.3	TEST METHODOLOGY AND CONSIDERATIONS .....	4
<b>2</b>	<b>TEST FACILITIES.....</b>	<b>5</b>
2.1	LOCATION .....	5
2.2	LABORATORY ACCREDITATIONS/RECOGNITIONS/CERTIFICATIONS .....	5
2.3	RADIATED EMISSIONS TEST SITE DESCRIPTION .....	6
2.3.1	<i>Semi-Anechoic Chamber Test Site.....</i>	<i>6</i>
2.3.2	<i>Open Area Tests Site (OATS) .....</i>	<i>7</i>
2.4	CONDUCTED EMISSIONS TEST SITE DESCRIPTION .....	8
<b>3</b>	<b>APPLICABLE STANDARD REFERENCES.....</b>	<b>8</b>
<b>4</b>	<b>LIST OF TEST EQUIPMENT.....</b>	<b>9</b>
<b>5</b>	<b>SUPPORT EQUIPMENT.....</b>	<b>10</b>
<b>6</b>	<b>EQUIPMENT UNDER TEST SETUP BLOCK DIAGRAM.....</b>	<b>10</b>
<b>7</b>	<b>SUMMARY OF TESTS.....</b>	<b>11</b>
7.1	ANTENNA REQUIREMENT – FCC 15.203 .....	11
7.2	POWER LINE CONDUCTED EMISSIONS – FCC 15.207, IC: RSS-GEN 8.8 .....	11
7.2.1	<i>Measurement Procedure.....</i>	<i>11</i>
7.2.2	<i>Measurement Results.....</i>	<i>11</i>
7.3	PEAK OUTPUT POWER - FCC 15.247(B)(2) IC: RSS-210 A8.4(1) .....	13
7.3.1	<i>Measurement Procedure (Conducted Method).....</i>	<i>13</i>
7.3.2	<i>Measurement Results.....</i>	<i>13</i>
7.4	CHANNEL USAGE REQUIREMENTS .....	14
7.4.1	<i>Carrier Frequency Separation – FCC 15.247(a)(1) IC: RSS-210 A8.1(b).....</i>	<i>14</i>
7.4.1.1	<i>Measurement Procedure.....</i>	<i>14</i>
7.4.1.2	<i>Measurement Results .....</i>	<i>14</i>
7.4.2	<i>Number of Hopping Channels – FCC 15.247(a)(1)(i) IC: RSS-210 A8.1(c).....</i>	<i>15</i>
7.4.2.1	<i>Measurement Procedure.....</i>	<i>15</i>
7.4.2.2	<i>Measurement Results .....</i>	<i>15</i>
7.4.3	<i>Channel Dwell Time – FCC 15.247(a)(1)(i) IC: RSS-210 A8.1(c).....</i>	<i>16</i>
7.4.4	<i>20dB / 99% Bandwidth - FCC 15.247(a)(1)(i) IC: RSS-210 A8.2(a).....</i>	<i>17</i>
7.4.4.1	<i>Measurement Procedure.....</i>	<i>17</i>
7.4.4.2	<i>Measurement Results .....</i>	<i>17</i>
7.5	BAND-EDGE COMPLIANCE AND SPURIOUS EMISSIONS .....	19
7.5.1	<i>Band-Edge Compliance of RF Conducted Emissions - FCC 15.247(d); IC RSS-210 A8.5..</i>	<i>19</i>
7.5.1.1	<i>Measurement Procedure.....</i>	<i>19</i>
7.5.1.2	<i>Measurement Results .....</i>	<i>19</i>
7.5.2	<i>RF Conducted Spurious Emissions - FCC 15.247(d); IC RSS-210 A8.5.....</i>	<i>20</i>
7.5.2.1	<i>Measurement Procedure.....</i>	<i>20</i>
7.5.2.2	<i>Measurement Results .....</i>	<i>20</i>
7.5.3	<i>Radiated Spurious Emissions - FCC 15.205, 15.209; IC RSS-210 2.2, RSS-Gen 8.9/8.10 ..</i>	<i>22</i>
7.5.3.1	<i>Measurement Procedure.....</i>	<i>22</i>
7.5.3.2	<i>Measurement Results .....</i>	<i>22</i>
7.5.3.3	<i>Sample Calculation: .....</i>	<i>23</i>
<b>8</b>	<b>CONCLUSION.....</b>	<b>24</b>

## 1 GENERAL

### 1.1 Purpose

The purpose of this report is to demonstrate compliance with Part 15 Subpart C of the FCC's Code of Federal Regulations and Industry Canada's Radio Standards Specification RSS-210 Certification for modular approval.

### 1.2 Product description

The ILC24FI module contains a frequency hopping spread spectrum radio operating in the 916.0 – 927.6 MHz ISM frequency band. The ILC24FI forms a complete electricity meter when installed in a housing and meter base.

#### Technical Details:

Detail	Description
Frequency Range	916.0 – 927.6 MHz
Number of Channels	25
Modulation Format	FSK
Data Rates	35.5 kbps /142.2 kbps
Operating Voltage	12 VDC

#### Antenna Details:

Item #	Antenna	Gain	Internal / External
1	PCTEL(MAXRAD) MFB9153 3dB Fiberglass Omnidirectional	5.15 dBi	External
2	PCTEL(MAXRAD) MFB9150 3dB Fiberglass Omnidirectional	2.15 dBi	External
3	Antenex TRA9023P(NP)* [white body] 3dB Gain	3 dBi	External
4	Antenex TRAB9023P(NP)* [black body] 3dB Gain	3 dBi	External
5	Inverted F-Type	3.49 dBi	Internal

#### Manufacturer Information:

Elster Solutions, LLC  
208 South Rogers Lane  
Raleigh, NC 27610

Test Sample Serial Numbers: 5D26152G0301 0 1144600047 (Radiated), 5D26152G0301 0 1144600021 (Conducted)

Test Sample Condition: The test samples were provided in good working order with no visible defects.

### **1.3 Test Methodology and Considerations**

All modes of operation, including all available data rates, were evaluated. The data presented in this report represents the worst case where applicable.

For radiated emissions the EUT was tested in an orientation representative of final installation.

The highest gain of each antenna type was evaluated for radiated emissions.

The EUT utilizes 25 hopping channels in the range from 902.4 MHz to 927.6 MHz using multiple hopping tables. Data was collected using multiple hopping tables to show compliance for all possible operating conditions (i.e. hopping band-edge at extreme operating band-edges).

For use with external antennas, the EUT utilizes a passive isolation board between the RF output and antenna. The isolation board was used in the test setup for testing external antennas and will be included in the final installation.

Software power setting during test: 0X69

## 2 TEST FACILITIES

### 2.1 Location

The radiated and conducted emissions test sites are located at the following address:

Advanced Compliance Solutions  
5015 B.U. Bowman Drive  
Buford, GA 30518  
Phone: (770) 831-8048  
Fax: (770) 831-8598

### 2.2 Laboratory Accreditations/Recognitions/Certifications

ACS is accredited to ISO/IEC 17025 by the National Institute of Standards and Technology under their National Voluntary Laboratory Accreditation Program (NVLAP), Lab Code 200612-0. Unless otherwise specified, all tests methods described within this report are covered under the ISO/IEC 17025 scope of accreditation.

The Semi-Anechoic Chamber Test Site, Open Area Test Site (OATS) and Conducted Emissions Site have been fully described, submitted to, and accepted by the FCC, Industry Canada and the Japanese Voluntary Control Council for Interference by information technology equipment.

FCC Registration Number: 511277

Industry Canada Lab Code: IC 4175A

VCCI Member Number: 1831

- VCCI OATS Registration Number R-1526
- VCCI Conducted Emissions Site Registration Number: C-1608

## 2.3 Radiated Emissions Test Site Description

### 2.3.1 Semi-Anechoic Chamber Test Site

The Semi-Anechoic Chamber Test Site consists of a 20' x 30' x 18' shielded enclosure. The chamber is lined with Toyo Ferrite Grid Absorber, model number FFG-1000. The ferrite tile grid is 101 x 101 x 19mm thick and weighs approximately 550 grams. These tiles are mounted on steel panels and installed directly on the inner walls of the chamber.

The turntable is 150cm in diameter and is located 160cm from the back wall of the chamber. The chamber is grounded via 1 – 8' copper ground rod, installed at the center of the back wall, it is bound to the ground plane using 3/4" stainless steel braided cable.

The turntable is all steel, flush mounted table installed in an all steel frame. The table is remotely operated from inside the control room located 25' from the range. The turntable is electrically bonded to the surrounding ground plane via steel fingers installed on the edge of the turn table. The steel fingers make constant contact with the ground plane during operation.

Behind the turntable is a 3' x 6' x 4' deep shielded pit used for support equipment if necessary. The pit is equipped with 1 – 4" PVC chases from the turntable to the pit that allow for cabling to the EUT if necessary. The underside of the turntable can be accessed from the pit so cables can be supplied to the EUT from the pit.

A diagram of the Semi-Anechoic Chamber Test Site is shown in Figure 2.3-1 below:

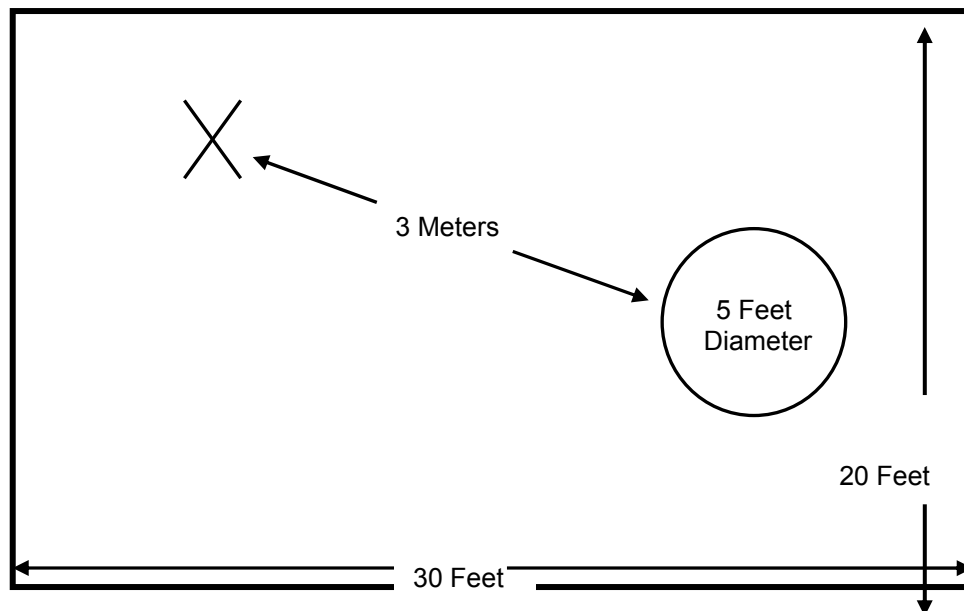

Figure 2.3-1: Semi-Anechoic Chamber Test Site

### 2.3.2 Open Area Tests Site (OATS)

The open area test site consists of a 40' x 66' concrete pad covered with a perforated electro-plated galvanized sheet metal. The perforations in the sheet metal are 1/8" holes that are staggered every 3/16". The individual sheets are placed to overlap each other by 1/4" and are riveted together to provide a continuous seam. Rivets are spaced every 3" in a 3 x 20 meter perimeter around the antenna mast and EUT area. Rivets in the remaining area are spaced as necessary to properly secure the ground plane and maintain the electrical continuity.

The entire ground plane extends 12' beyond the turntable edge and 16' beyond the antenna mast when set to a 10 meter measurement distance. The ground plane is grounded via 4 – 8' copper ground rods, each installed at a corner of the ground plane and bound to the ground plane using 3/4" stainless steel braided cable.

The turntable is an all aluminum 10' flush mounted table installed in an all aluminum frame. The table is remotely operated from inside the control room located 40' from the range. The turntable is electrically bonded to the surrounding ground plane via steel fingers installed on the edge of the turn table. The steel fingers make constant contact with the ground plane during operation.

Adjacent to the turntable is a 7' x 7' square and 4' deep concrete pit used for support equipment if necessary. The pit is equipped with 5 – 4" PVC chases from the pit to the control room that allow for cabling to the EUT if necessary. The underside of the turntable can be accessed from the pit so cables can be supplied to the EUT from the pit. The pit is covered with 2 sheets of 1/4" diamond style re-enforced steel sheets. The sheets are painted to match the perforated steel ground plane; however the underside edges have been masked off to maintain the electrical continuity of the ground plane. All reflecting objects are located outside of the ellipse defined in ANSI C63.4.

A diagram of the Open Area Test Site is shown in Figure 2.3-2 below:

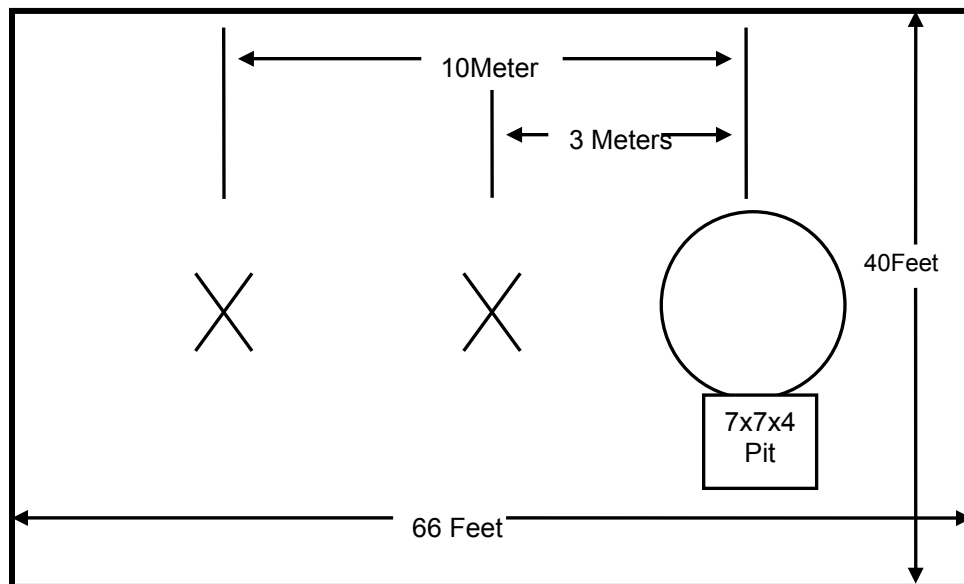

Figure 2.3-2: Open Area Test Site

## 2.4 Conducted Emissions Test Site Description

The AC mains conducted EMI site is located in the main EMC lab. It consists of an 8' x 8' solid aluminum horizontal ground reference plane (GRP) bonded every 3" to an 8' X 8' vertical ground plane.

The site is of sufficient size to test table top and floor standing equipment in accordance with section 6.1.4 of ANSI C63.4.

A diagram of the room is shown below in figure 2.4-1:

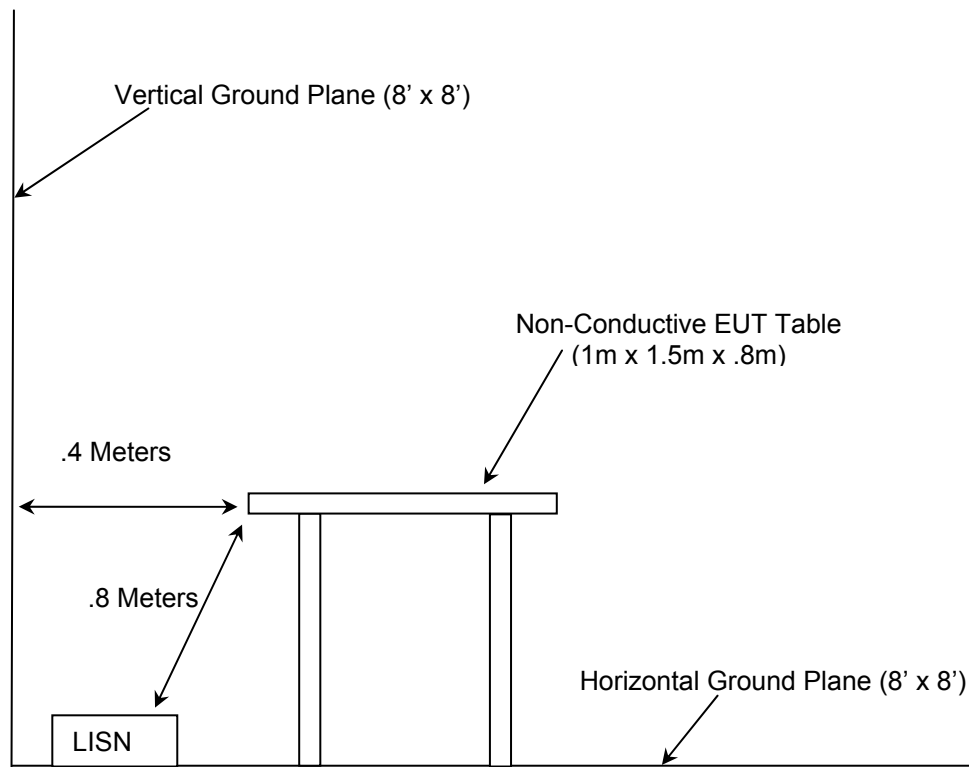

Figure 2.4-1: AC Mains Conducted EMI Site

## 3 APPLICABLE STANDARD REFERENCES

The following standards were used:

- ❖ ANSI C63.10-2013: American National Standard of Procedures for Compliance Testing of Unlicensed Wireless Devices
- ❖ US Code of Federal Regulations (CFR): Title 47, Part 2, Subpart J: Equipment Authorization Procedures, 2015
- ❖ US Code of Federal Regulations (CFR): Title 47, Part 15, Subpart C: Radio Frequency Devices, Intentional Radiators, 2015
- ❖ FCC Public Notice DA 00-705 – Filing and Measurement Guidelines for Frequency Hopping Spread Spectrum Systems, March 30, 2000
- ❖ Industry Canada Radio Standards Specification: RSS-210 – Low-power License-exempt Radiocommunication Devices (All Frequency Bands): Category I Equipment, Issue 8, December 2010
- ❖ Industry Canada Radio Standards Specification: RSS-GEN – General Requirements and Information for the Certification of Radiocommunication Equipment, Issue 4, Nov 2014.



#### 4 LIST OF TEST EQUIPMENT

The calibration interval of test equipment is annually or the manufacturer's recommendations. Where the calibration interval deviates from the annual cycle based on the instrument manufacturer's recommendations, it shall be stated below.

**Table 4-1: Test Equipment**

AssetID	Manufacturer	Model #	Equipment Type	Serial #	Last Calibration Date	Calibration Due Date
1	Rohde & Schwarz	ESMI - Display	Spectrum Analyzers	833771/007	7/11/2014	7/11/2016
2	Rohde & Schwarz	ESMI-Receiver	Spectrum Analyzers	839587/003	7/11/2014	7/11/2016
30	Spectrum Technologies	DRH-0118	Antennas	970102	4/23/2013	4/23/2015
40	EMCO	3104	Antennas	3211	2/14/2013	2/14/2015
73	Agilent	8447D	Amplifiers	2727A05624	7/15/2014	7/15/2015
167	ACS	Chamber EMI Cable Set	Cable Set	167	10/28/2014	10/28/2015
168	Hewlett Packard	11947A	Attenuators	44829	1/19/2015	1/19/2016
267	Agilent	N1911A	Meters	MY45100129	7/30/2013	7/30/2015
268	Agilent	N1921A	Sensors	MY45240184	7/30/2013	7/30/2015
292	Florida RF Cables	SMR-290AW- 480.0-SMR	Cables	None	3/17/2014	3/17/2015
316	Rohde Schwarz	ESH3-Z5	LISN	861189-010	8/15/2013	8/15/2015
324	ACS	Belden	Cables	8214	6/4/2014	6/4/2015
331	Microwave Circuits	H1G513G1	Filters	31417	6/2/2014	6/2/2015
338	Hewlett Packard	8449B	Amplifiers	3008A01111	7/30/2013	7/30/2015
340	Aeroflex/Weinschel	AS-20	Attenuators	7136	7/14/2014	7/14/2015
412	Electro Metrics	LPA-25	Antennas	1241	7/24/2014	7/24/2016
422	Florida RF	SMS-200AW-72.0- SMR	Cables	805	11/5/2014	11/5/2015
616	Florida RF Cables	SMRE-200W-12.0- SMRE	Cables	N/A	9/10/2014	9/10/2015
622	Rohde & Schwarz	FSV40	Analyzers	101338	7/12/2014	7/12/2015
RE361	Agilent	AT/E7405A	Analyzers	MY42000089	5/30/2014	5/30/2016

5 SUPPORT EQUIPMENT

Table 5-1: Support Equipment

Item	Equipment Type	Manufacturer	Model Number	Serial Number
1	Signal/Power Adaptor PCB	Elster Solutions, LLC	N/A	N/A
2	AC Adaptor	V-Infinity	EMSA150120K-P5P-SZ	N/A
3	DC Power Supply	Hewlett Packard	E3630A	KR64308603
4	Isolation Board	Elster	1B12154G02	N/A
5	Electric Utility Meter	Milbank MFG.	Type 3R	N/A

6 EQUIPMENT UNDER TEST SETUP BLOCK DIAGRAM

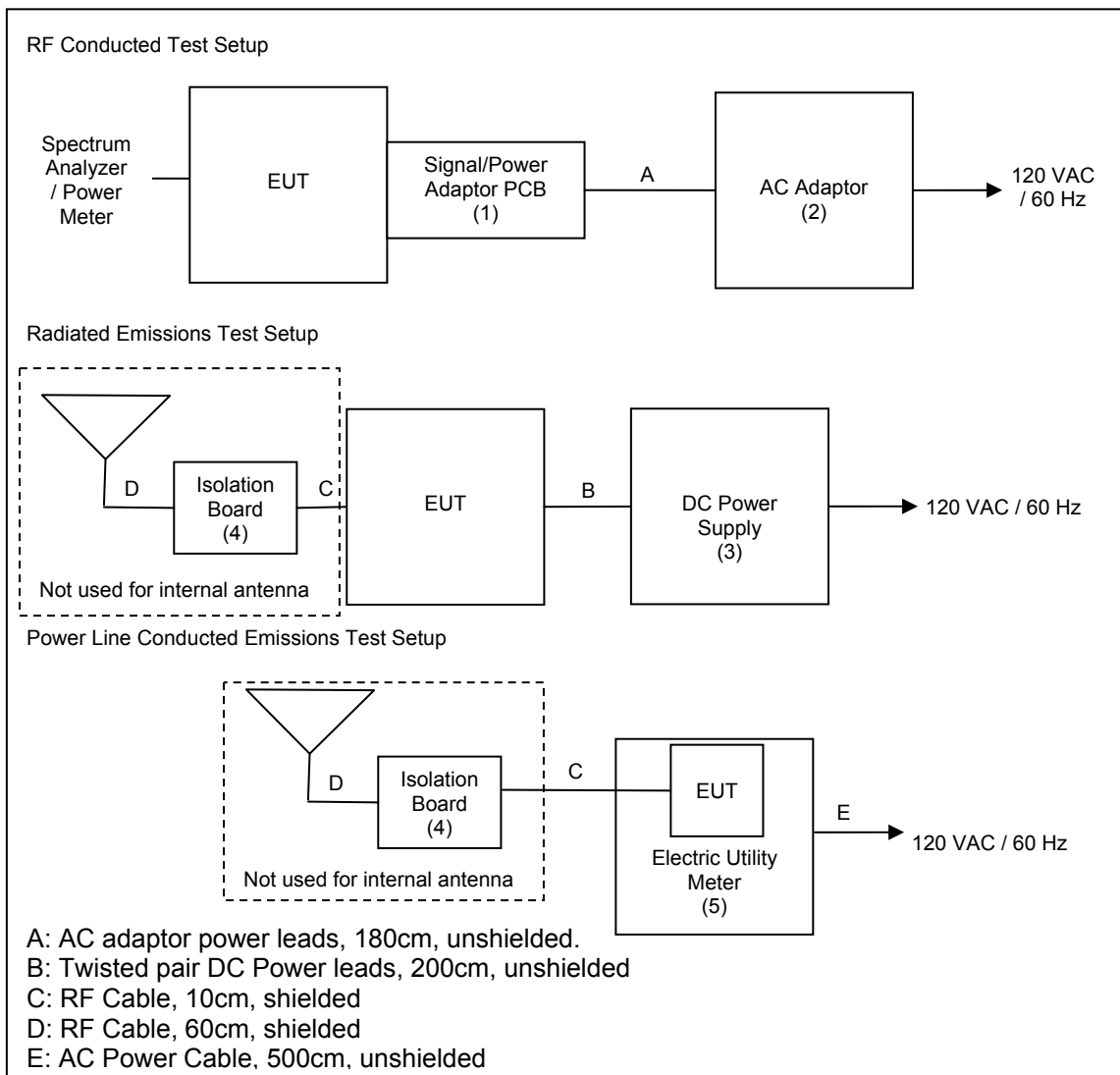

Figure 6-1: Test Setup Block Diagram

## 7 SUMMARY OF TESTS

Along with the tabular data shown below, plots were taken of all signals deemed important enough to document.

### 7.1 Antenna Requirement – FCC 15.203

The EUT utilizes a MCX on-board connector. The MCX connector is considered unique thus meeting the requirements of Section 15.203.

### 7.2 Power Line Conducted Emissions – FCC 15.207, IC: RSS-Gen 8.8

#### 7.2.1 Measurement Procedure

ANSI C63.4 sections 6 and 7 were the guiding documents for this evaluation. Conducted emissions were performed from 150kHz to 30MHz with the spectrum analyzer's resolution bandwidth set to 9kHz and the video bandwidth set to 30kHz. The calculation for the conducted emissions is as follows:

**Corrected Reading = Analyzer Reading + LISN Loss + Cable Loss**

**Margin = Applicable Limit - Corrected Reading**

#### 7.2.2 Measurement Results

**Table 7.2.2-1: Conducted EMI Results Line 1 – Antenna 1**

Frequency (MHz)	Uncorrected Reading		Total Correction Factor (dB)	Corrected Level		Limit		Margin (dB)	
	Quasi-Peak	Average		Quasi-Peak	Average	Quasi-Peak	Average	Quasi-Peak	Average
17.6954	23.487	23.287	11.102	34.589	34.39	60	50	25.411	15.61
16.2294	24.477	24.24	10.97	35.446	35.21	60	50	24.554	14.79
0.51235	18.119	12.632	10.202	28.321	22.834	56	46	27.679	23.166
0.395413	22.009	15.153	10.179	32.188	25.332	58.988	48.988	26.8	23.656
0.199175	31.543	23.405	10.16	41.703	33.565	64.595	54.595	22.892	21.03
0.166177	27.246	19.535	10.16	37.406	29.695	65.538	55.538	28.132	25.842

**Table 7.2.2-2: Conducted EMI Results Line 2 – Antenna 1**

Frequency (MHz)	Uncorrected Reading		Total Correction Factor (dB)	Corrected Level		Limit		Margin (dB)	
	Quasi-Peak	Average		Quasi-Peak	Average	Quasi-Peak	Average	Quasi-Peak	Average
2.44749	23.124	16.391	10.22	33.344	26.611	56	46	22.656	19.389
1.7963	22.756	18.033	10.22	32.976	28.253	56	46	23.024	17.747
0.50845	23.399	18.861	10.201	33.6	29.062	56	46	22.4	16.938
0.455456	24.373	20.794	10.196	34.568	30.989	57.273	47.273	22.704	16.283
0.197838	33.845	27.081	10.179	44.024	37.26	64.633	54.633	20.609	17.373
0.154106	27.537	19.331	10.17	37.707	29.501	65.883	55.883	28.176	26.382

**Table 7.2.2-3: Conducted EMI Results Line 1 – Antenna 3**

Frequency (MHz)	Uncorrected Reading		Total Correction Factor (dB)	Corrected Level		Limit		Margin (dB)	
	Quasi-Peak	Average		Quasi-Peak	Average	Quasi-Peak	Average	Quasi-Peak	Average
18.2443	22.449	22.175	11.099	33.548	33.274	60	50	26.452	16.726
17.6951	21.989	21.884	11.102	33.091	32.986	60	50	26.909	17.014
0.505999	18.042	13.391	10.201	28.243	23.593	56	46	27.757	22.407
0.460175	21.089	15.543	10.192	31.281	25.735	57.138	47.138	25.857	21.402
0.264119	29.642	19.46	10.163	39.805	29.623	62.739	52.739	22.935	23.116
0.199025	30.018	22.898	10.16	40.178	33.058	64.599	54.599	24.422	21.541

**Table 7.2.2-4: Conducted EMI Results Line 2 – Antenna 3**

Frequency (MHz)	Uncorrected Reading		Total Correction Factor (dB)	Corrected Level		Limit		Margin (dB)	
	Quasi-Peak	Average		Quasi-Peak	Average	Quasi-Peak	Average	Quasi-Peak	Average
1.91056	23.105	17.45	10.22	33.325	27.67	56	46	22.675	18.33
1.85649	23.13	17.969	10.22	33.35	28.189	56	46	22.65	17.811
0.51325	23.967	18.95	10.201	34.168	29.151	56	46	21.832	16.849
0.502938	24.551	20.273	10.2	34.751	30.474	56	46	21.249	15.526
0.196687	33.44	27.86	10.179	43.619	38.039	64.666	54.666	21.047	16.627
0.170919	27.827	22.038	10.17	37.997	32.209	65.402	55.402	27.405	23.194

**Table 7.2.2-5: Conducted EMI Results Line 1 – Antenna 5**

Frequency (MHz)	Uncorrected Reading		Total Correction Factor (dB)	Corrected Level		Limit		Margin (dB)	
	Quasi-Peak	Average		Quasi-Peak	Average	Quasi-Peak	Average	Quasi-Peak	Average
18.245	22.295	21.991	11.099	33.394	33.09	60	50	26.606	16.91
16.2298	23.569	23.289	10.97	34.538	34.259	60	50	25.462	15.741
16.1686	22.578	22.254	10.961	33.539	33.215	60	50	26.461	16.785
14.2137	20.063	19.356	10.919	30.982	30.275	60	50	29.018	19.725
0.501349	15.092	10.195	10.2	25.292	20.395	56	46	30.708	25.605
0.196875	24.696	18.257	10.16	34.856	28.417	64.661	54.661	29.805	26.244

**Table 7.2.2-6: Conducted EMI Results Line 2 – Antenna 5**

Frequency (MHz)	Uncorrected Reading		Total Correction Factor (dB)	Corrected Level		Limit		Margin (dB)	
	Quasi-Peak	Average		Quasi-Peak	Average	Quasi-Peak	Average	Quasi-Peak	Average
18.2453	21.065	20.581	10.615	31.679	31.196	60	50	28.321	18.804
2.35627	17.361	11.665	10.22	27.581	21.885	56	46	28.419	24.115
2.31334	17.51	11.82	10.22	27.73	22.04	56	46	28.27	23.96
1.90685	17.458	12.797	10.22	27.678	23.017	56	46	28.322	22.983
0.49155	16.058	12.109	10.199	26.257	22.308	56.241	46.241	29.985	23.933
0.154464	25.418	18.796	10.17	35.588	28.966	65.872	55.872	30.285	26.906

### 7.3 Peak Output Power - FCC 15.247(b)(2) IC: RSS-210 A8.4(1)

#### 7.3.1 Measurement Procedure (Conducted Method)

The RF output port of the EUT was directly connected to the input of a power meter. The device employs < 50 channels at any given time therefore the power is limited to 0.25 Watt.

#### 7.3.2 Measurement Results

**Table 7.3.2-1: RF Output Power**

<b>Frequency [MHz]</b>	<b>Level [dBm]</b>
916.0	23.52
921.6	23.53
927.6	23.53

7.4 Channel Usage Requirements

7.4.1 Carrier Frequency Separation – FCC 15.247(a)(1) IC: RSS-210 A8.1(b)

7.4.1.1 Measurement Procedure

The RF output port of the EUT was directly connected to the input of the spectrum analyzer. The span of the spectrum analyzer was set wide enough to capture two adjacent peaks. The RBW and VBW were set to 10 kHz and 30 kHz respectively.

7.4.1.2 Measurement Results

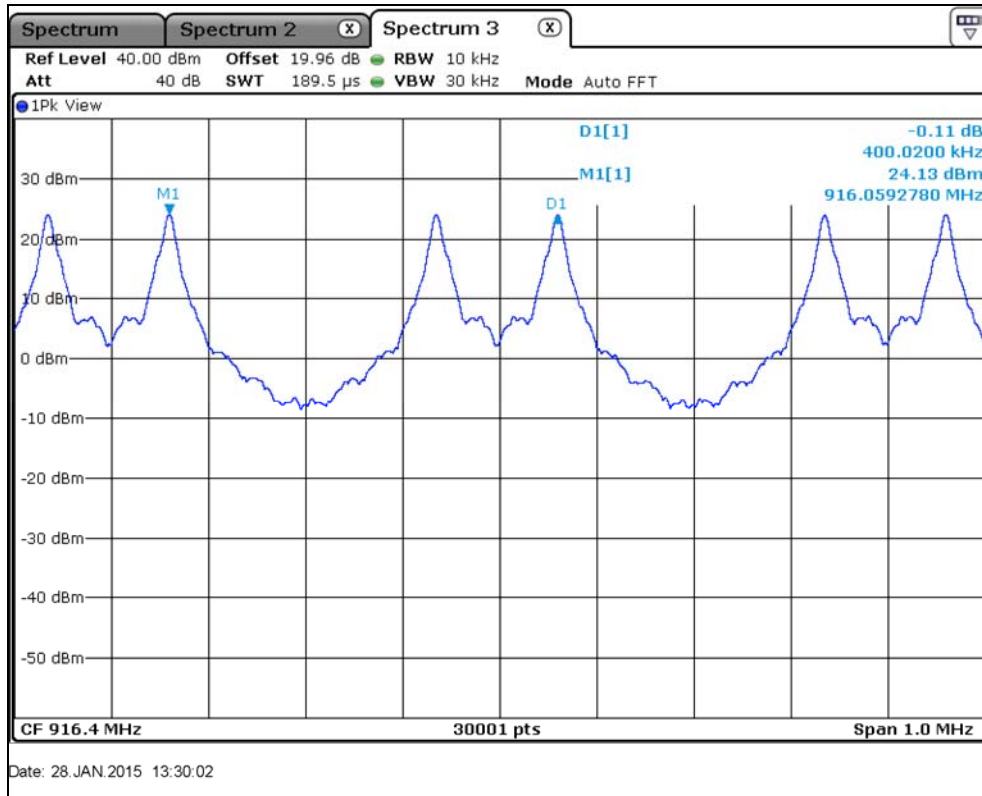

Figure 7.4.1.2-1: Carrier Frequency

7.4.2 Number of Hopping Channels – FCC 15.247(a)(1)(i) IC: RSS-210 A8.1(c)

7.4.2.1 Measurement Procedure

The RF output port of the EUT was directly connected to the input of the spectrum analyzer. The span of the spectrum analyzer was set wide enough to capture the frequency band of operation. The RBW was set to 200kHz and VBW set to ≥ RBW.

7.4.2.2 Measurement Results

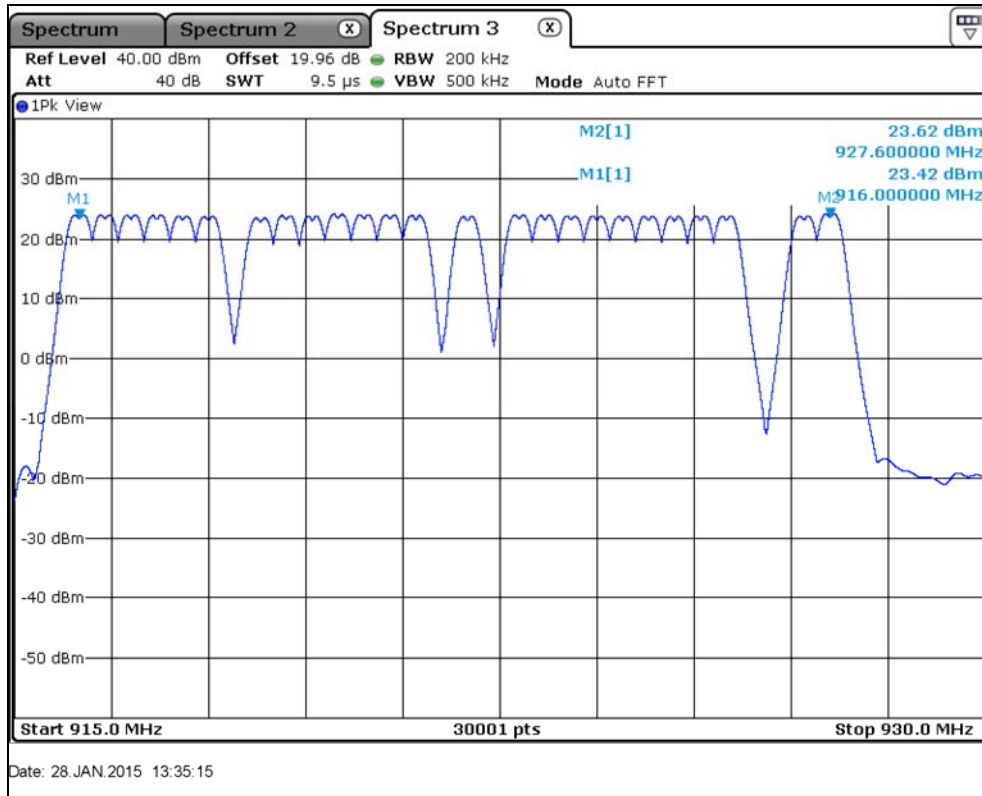

Figure 7.4.2.2-1: Number of Hopping Channels

### 7.4.3 Channel Dwell Time – FCC 15.247(a)(1)(i) IC: RSS-210 A8.1(c)

The EUT test mode does not generate a worst case channel dwell time therefore a detailed engineering analysis is provided in the theory of operation.

As described in the theory of operation, the maximum channel transmitter dwell time is 200ms within a 10s period thus meeting the limit of 400ms for all modes of operation.



**7.4.4 20dB / 99% Bandwidth - FCC 15.247(a)(1)(i) IC: RSS-210 A8.2(a)****7.4.4.1 Measurement Procedure**

The RF output port of the EUT was directly connected to the input of the spectrum analyzer. The span of the spectrum analyzer display was set between two times and five times the occupied bandwidth (OBW) of the emission. The RBW of the spectrum analyzer was set to approximately 1 % to 5 % of the OBW. The trace was set to max hold with a peak detector active. The marker delta measurement function of the analyzer was utilized to determine the 20 dB bandwidth of the emission.

The occupied bandwidth measurement function of the spectrum analyzer was used to measure the 99% bandwidth. The span of the analyzer was set to capture all products of the modulation process, including the emission sidebands. The resolution bandwidth was set to 1% to 5% of the occupied bandwidth. The video bandwidth was set to 3 times the resolution bandwidth. A peak detector was used.

**7.4.4.2 Measurement Results****Table 7.4.4.2-1: 20dB / 99% Bandwidth**

Frequency [MHz]	20dB Bandwidth [kHz]	99% Bandwidth [kHz]
916.0	314.76	409.55
921.6	314.42	434.15
927.6	314.39	405.21

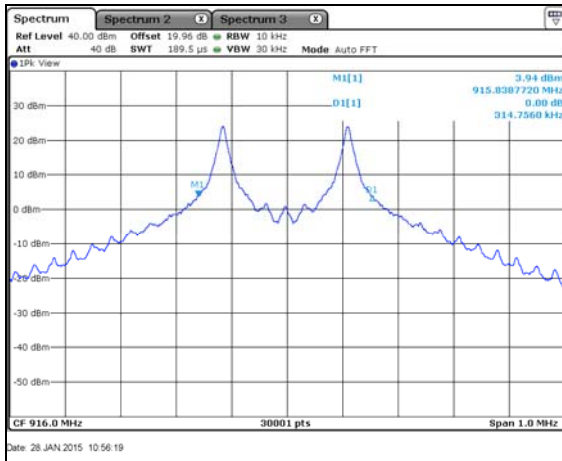

Figure 7.4.4.2-1: 20dB BW Low Channel

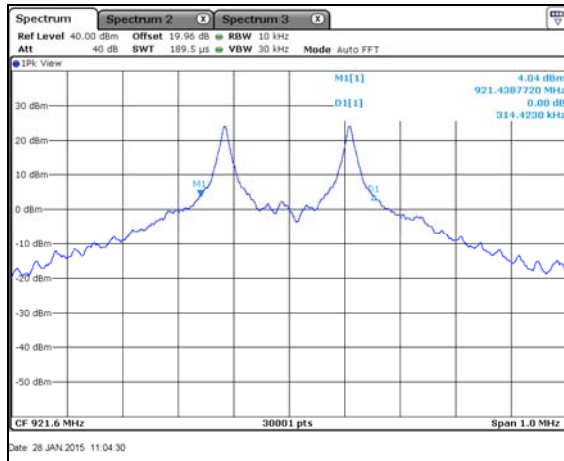

Figure 7.4.4.2-2: 20dB BW Mid Channel

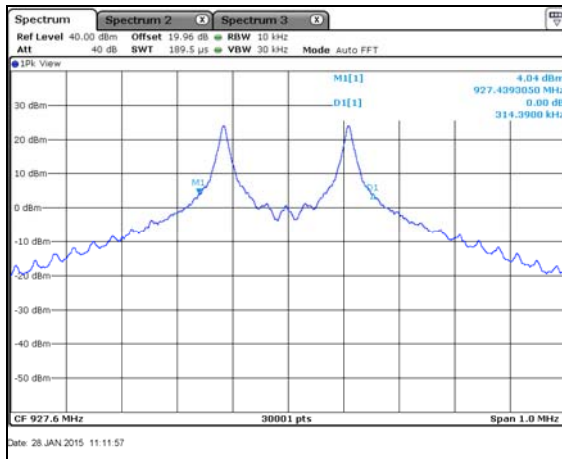

Figure 7.4.4.2-3: 20dB BW High Channel

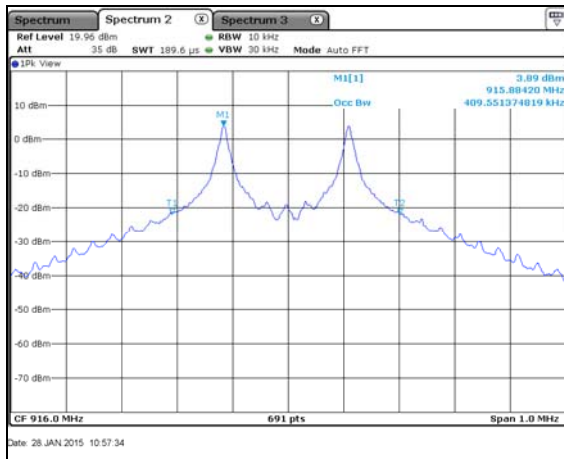

Figure 7.4.4.2-4: 99% BW Low Channel

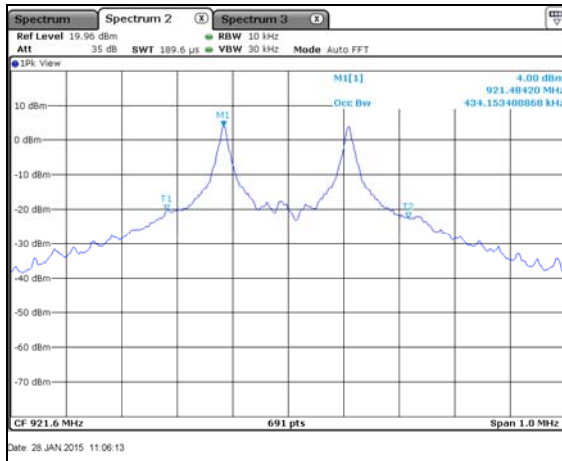

Figure 7.4.4.2.5: 99% BW Mid Channel

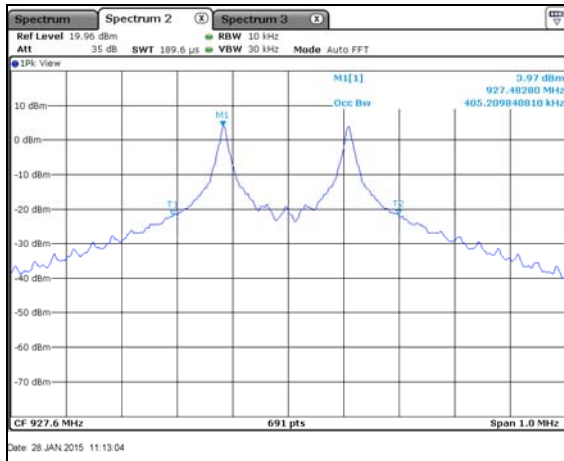

Figure 7.4.4.2-6: 99% BW High Channel

## 7.5 Band-Edge Compliance and Spurious Emissions

### 7.5.1 Band-Edge Compliance of RF Conducted Emissions - FCC 15.247(d); IC RSS-210 A8.5

#### 7.5.1.1 Measurement Procedure

The RF output port of the EUT was directly connected to the input of the spectrum analyzer. The EUT was investigated at the lowest and highest channel available to determine band-edge compliance. For each measurement the spectrum analyzer's RBW was set to 100 kHz, and the VBW was set to 300 kHz.

#### 7.5.1.2 Measurement Results

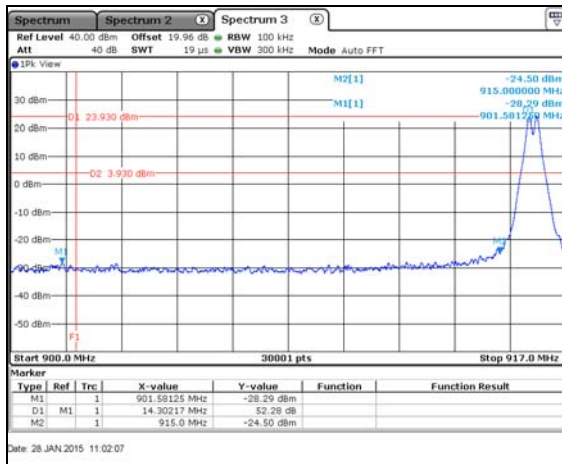

Figure 7.5.1.2-1: Lower Band-edge

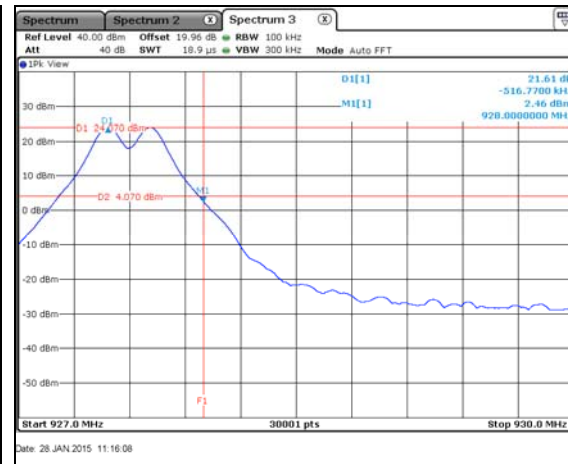

Figure 7.5.1.2-2: Upper Band-edge

#### HOPPING MODE:

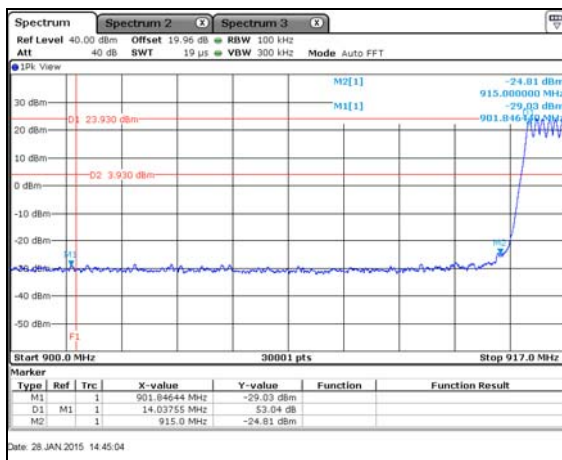

Figure 7.5.1.2-3: Lower Band-edge – Hopping

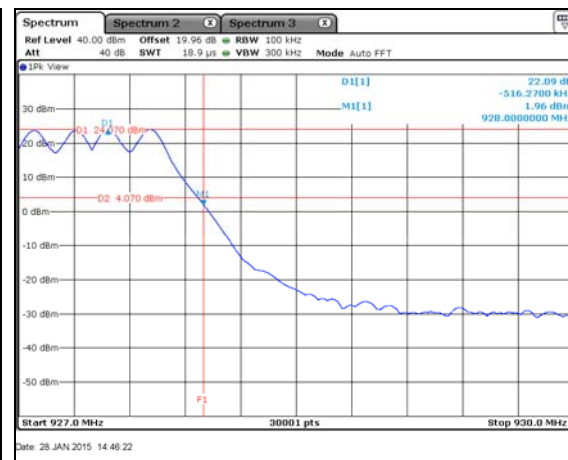

Figure 7.5.1.2-4: Upper Band-edge – Hopping

## 7.5.2 RF Conducted Spurious Emissions - FCC 15.247(d); IC RSS-210 A8.5

### 7.5.2.1 Measurement Procedure

The RF output port of the EUT was directly connected to the input of the spectrum analyzer. The EUT was investigated for conducted spurious emissions from 30MHz to 10GHz, 10 times the highest fundamental frequency. Measurements were made at the low, center and high channels of the EUT. For each measurement, the spectrum analyzer's RBW was set to 100kHz. A peak detector function was used with the trace set to max hold.

### 7.5.2.2 Measurement Results

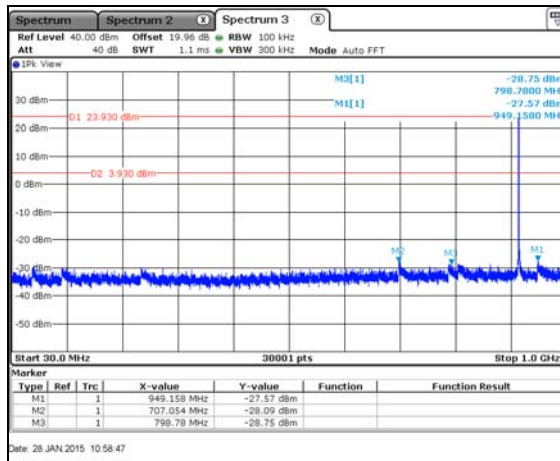

Figure 7.5.2.2-1: 30 MHz – 1 GHz – Low Channel

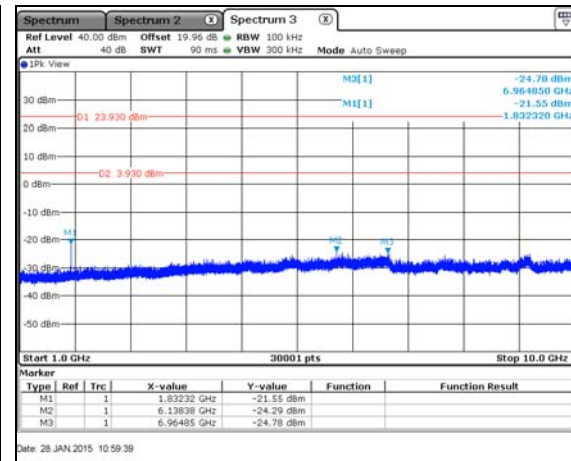

Figure 7.5.2.2-2: 1 GHz – 10 GHz – Low Channel

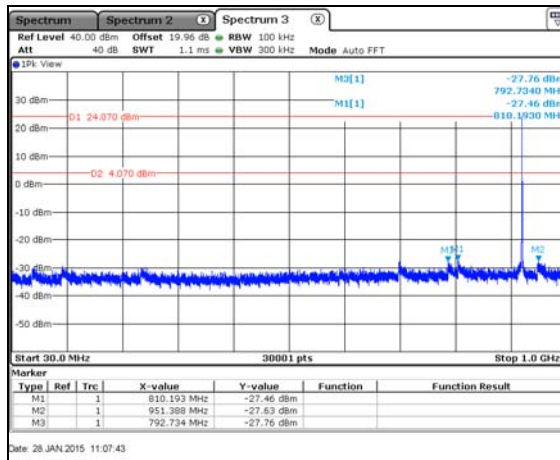

Figure 7.5.2.2-3: 30 MHz – 1 GHz – Mid Channel

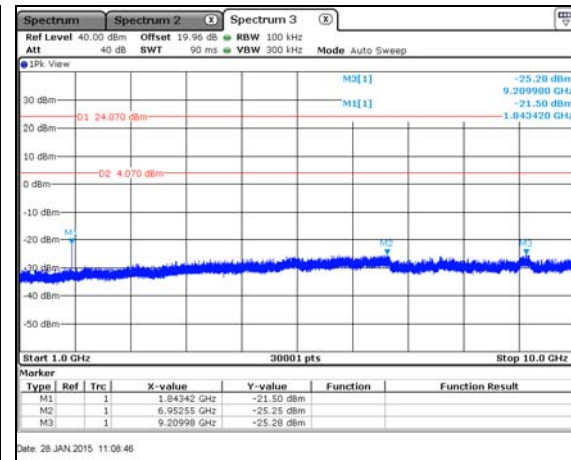

Figure 7.5.2.2-4: 1 GHz – 10 GHz – Mid Channel

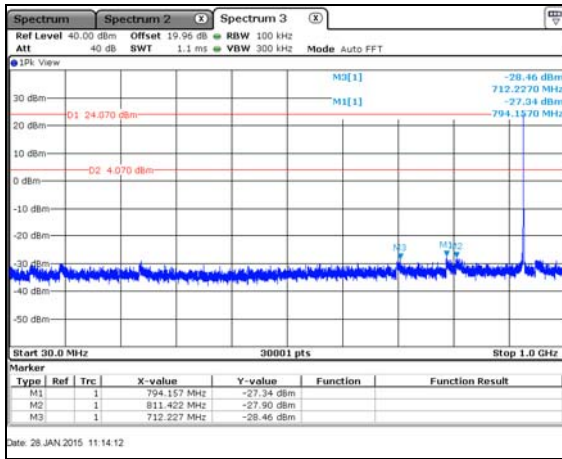

Figure 7.5.2.2-5: 30 MHz – 1 GHz – High Channel

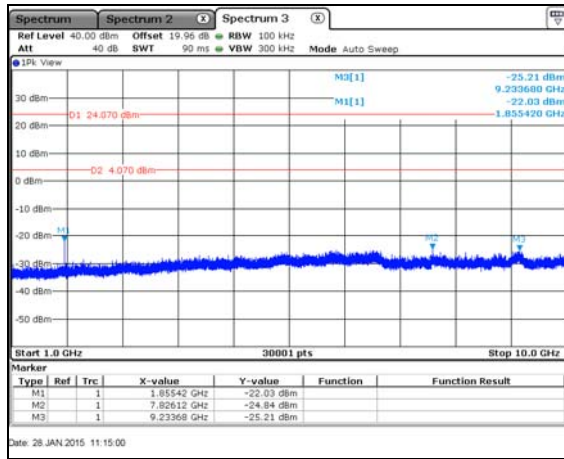

Figure 7.5.2.2-6: 1 GHz – 10 GHz – High Channel

**7.5.3 Radiated Spurious Emissions - FCC 15.205, 15.209; IC RSS-210 2.2, RSS-Gen 8.9/8.10**

**7.5.3.1 Measurement Procedure**

Radiated emissions tests were made over the frequency range of 30MHz to 10GHz, 10 times the highest fundamental frequency.

The EUT was rotated through 360° and the receive antenna height was varied from 1m to 4m so that the maximum radiated emissions level would be detected. For frequencies below 1000MHz, quasi-peak measurements were made using a resolution bandwidth RBW of 120 kHz and a video bandwidth VBW of 300 kHz. For frequencies above 1000MHz, peak and average measurements were made with RBW and VBW of 1 MHz and 3MHz respectively.

The EUT was caused to generate a continuous modulated carrier on the hopping channel.

Each emission found to be in a restricted band was compared to the applicable radiated emission limits.

**7.5.3.2 Measurement Results**

**Table 7.5.3.2-1: Radiated Spurious Emissions Tabulated Data – Antenna 1**

Frequency (MHz)	Level (dBuV)		Antenna Polarity (H/V)	Correction Factors (dB)	Corrected Level (dBuV/m)		Limit (dBuV/m)		Margin (dB)	
	pk	Qpk/Avg			pk	Qpk/Avg	pk	Qpk/Avg	pk	Qpk/Avg
<b>Low Channel</b>										
No emissions detected above the noise floor of the measurement system										
<b>Middle Channel</b>										
No emissions detected above the noise floor of the measurement system										
<b>High Channel</b>										
2782.8	45.73	33.91	H	-4.37	41.36	29.54	74.0	54.0	32.6	24.5

**Table 7.5.3.2-2: Radiated Spurious Emissions Tabulated Data – Antenna 3**

Frequency (MHz)	Level (dBuV)		Antenna Polarity (H/V)	Correction Factors (dB)	Corrected Level (dBuV/m)		Limit (dBuV/m)		Margin (dB)	
	pk	Qpk/Avg			pk	Qpk/Avg	pk	Qpk/Avg	pk	Qpk/Avg
<b>Low Channel</b>										
2748	46.31	34.52	V	-4.51	41.80	30.01	74.0	54.0	32.2	24.0
<b>Middle Channel</b>										
2764.8	46.65	35.82	V	-4.44	42.21	31.38	74.0	54.0	31.8	22.6
<b>High Channel</b>										
2782.8	46.14	35.36	H	-4.37	41.77	30.99	74.0	54.0	32.2	23.0
2782.8	47.63	37.57	V	-4.37	43.26	33.20	74.0	54.0	30.7	20.8

**Table 7.5.3.2-3: Radiated Spurious Emissions Tabulated Data – Antenna 5**

Frequency (MHz)	Level (dBuV)		Antenna Polarity (H/V)	Correction Factors (dB)	Corrected Level (dBuV/m)		Limit (dBuV/m)		Margin (dB)	
	pk	Qpk/Avg			pk	Qpk/Avg	pk	Qpk/Avg	pk	Qpk/Avg
<b>Low Channel</b>										
No emissions detected above the noise floor of the measurement system.										
<b>Middle Channel</b>										
2764.8	46.18	35.61	H	-4.44	41.74	31.17	74.0	54.0	32.3	22.8
2764.8	46.37	35.79	V	-4.44	41.93	31.35	74.0	54.0	32.1	22.6
<b>High Channel</b>										
2782.8	47.22	37.29	H	-4.37	42.85	32.92	74.0	54.0	31.1	21.1
2782.8	46.07	36.20	V	-4.37	41.70	31.83	74.0	54.0	32.3	22.2

**7.5.3.3 Sample Calculation:**

$$R_C = R_U + CF_T$$

Where:

- CF<sub>T</sub> = Total Correction Factor (AF+CA+AG)-DC (Average Measurements Only)
- R<sub>U</sub> = Uncorrected Reading
- R<sub>C</sub> = Corrected Level
- AF = Antenna Factor
- CA = Cable Attenuation
- AG = Amplifier Gain
- DC = Duty Cycle Correction Factor

**Example Calculation: Peak – Antenna 3**

Corrected Level: 46.31 - 4.51 = 41.80dBuV/m  
 Margin: 74dBuV/m – 41.80dBuV/m = 32.2dB

**Example Calculation: Average**

Corrected Level: 34.52 - 4.51 - 0 = 30.01dBuV  
 Margin: 54dBuV – 30.01dBuV = 24.0dB

**8 CONCLUSION**

In the opinion of ACS, Inc. the ILC24FI, manufactured by Elster Solutions, LLC meets the requirements of FCC Part 15 subpart C and Industry Canada's Radio Standards Specification RSS-210.

**END REPORT**