

THB

“Bluetooth Comfort Module”
BCM001

OEM User

Operation Manual

Date of preparation: April 2003

General Notes:

This document is issued by Bury GmbH & Co.KG (hereinafter called Bury) in confidence, and is not to be reproduced in whole or in part without the prior written permission of Bury. The information contained herein is the property of Bury and is to be used only for the purpose for which it is submitted and is not to be released in whole or in part without the prior written permission of Bury.

Important

1. This module is intended to use for wireless audio and data transfer for OEM integration in final products.
2. When integrating the THB “Bluetooth Comfort Module” into a final product, the following information must be considered:
All products containing the module must be labelled. The label must be affixed on an exterior surface of the end product such that it will be visible upon inspection in compliance with the modular approval guidelines developed by the FCC.
The label must state “This device contains FCC ID QZ9-BURYBCM001”
In addition, the user manual for the end product must contain the following information:
"This device complies with Part 15 of the FCC Rules. Operation is subject to the following two conditions:
(1) this device may not cause harmful interference, and
(2) this device must accept any interference received,
including interference that may cause undesired operation."
3. Take care of electrostatic discharge while handling the module. This may destroy the module.
4. Don't place the module in a metal housing. This may reduce the operating distance.
5. This device and its antenna must not be co-located or operating in conjunction with any other antenna or transmitter.
6. For using antennas not mounted on the module see related document “Bluetooth Comfort Module Antenna Specification “. Take only the specified antennas, otherwise loss of FCC and Bluetooth Approval will result.
7. The users manual or instruction manual for an intentional or unintentional radiator shall caution the user that changes or modifications not expressly approved by the party responsible for compliance could void the user's authority to operate the equipment.
8. The OEM Manufacturer must not describe to the end user how to install or deinstall the Bluetooth Comfort Module.

Bluetooth module – Top side



Picture 1.

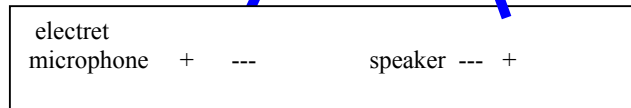

BURY GMBH & CO. KG • ROBERT-KOCH-STR. 1-7 • 32584 LÖHNE

Bluetooth module – Bottom side

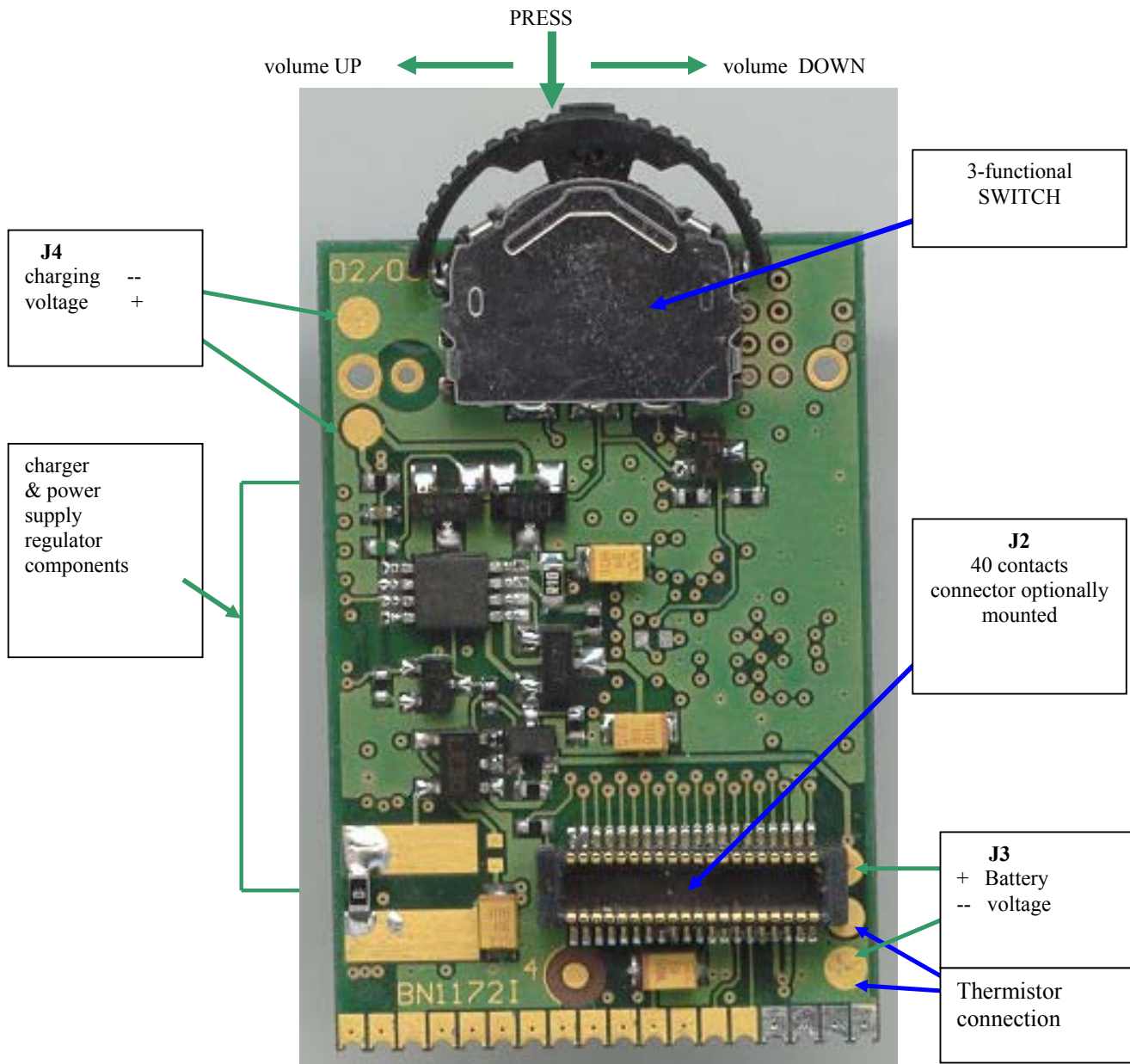

Picture 2.

18 - - 15 - - 12 - - 9 - - 6 - - 3 - -



J1 - 18 side contacts:

- | | | |
|------------------------|----------------------|--------------------------|
| 18 – Speaker + | 12 – Volume - | 6 – Voice IN + |
| 17 – Speaker - | 11 – Microphone mute | 5 – Voice IN - |
| 16 – Ground (supply -) | 10 – MFB/GPIO | 4 – Serial Data Receive |
| 15 – LED Green | 9 – REF_CLK | 3 – Serial Data Transmit |
| 14 – LED Red | 8 – VMIC | 2 – Supply voltage + |
| 13 – Volume + | 7 – RESET | 1 – Ground (supply -) |

Note: For detailed pinout description of J1 see [Table 2](#).

1. USAGE SCENARIO:

Turn On

Turn Off

Answer a call

Call Reject

volume up/down

Button functions

LED signals

2. ELECTRICAL DATA & CHARACTERISTICS:

Table 1. “Bluetooth Comfort Module” Electrical Data:

PARAMETER	VALUE	
Charging voltage - DC	4,8 ÷ 5,8	V
Absolute maximum charging voltage	6,0	V
Main power supply (onboard regulator)	3,0	V
Regulator maximum current	180	mA
Battery voltage	typ. 3,7	V
	max. 4,2	V
Minimum operational battery voltage	min. 3,2	V
Absolute maximum supply voltage NOTE! Supply voltage higher than 6 Volts - only if battery charger and its output capacitor are not mounted !!!	16,0	V

Battery type	Lithium Polymer
--------------	-----------------

Supply options:

There is possibility to supply module from battery or from any other external power supply, regarding maximum input voltage of voltage regulator and other components.

3. THREE options for connecting external signals & power supply:

- 3.1. PCB pads shown in Picture 1. and Picture 2.
- 3.2. 40 contacts connector on bottom side shown in Picture 2.
- 3.3. Side contacts on bottom of Picture 2.

4. TWO options for operation:

- 4.1. Through 3-functional switch and I/O lines mentioned in points 3.2. and 3.3.
- 4.2. Through AT commands

5. Microphone & speaker connections.

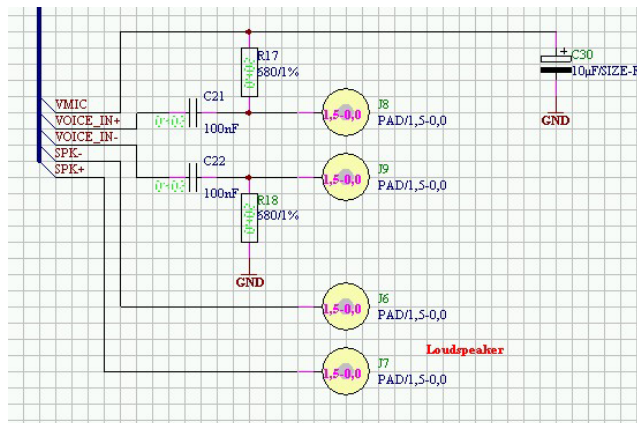

Picture 3. Part of Bluetooth Comfort Module schematic - audio connections

There are 3 options for connecting audio signals:

Audio input:

- electret microphone connections to pads J8, J9 on top of board
- VOICE_IN – (J1 – 5) & VOICE_IN + (J1 – 6) audio direct input and also microphone power supply VMIC (J1 – 8) - if needed
- J2 connector

Audio output:

- loudspeaker connections to pads J6, J7 on top of board
- J1–18 & J1–17 - side contacts
- J2 connector

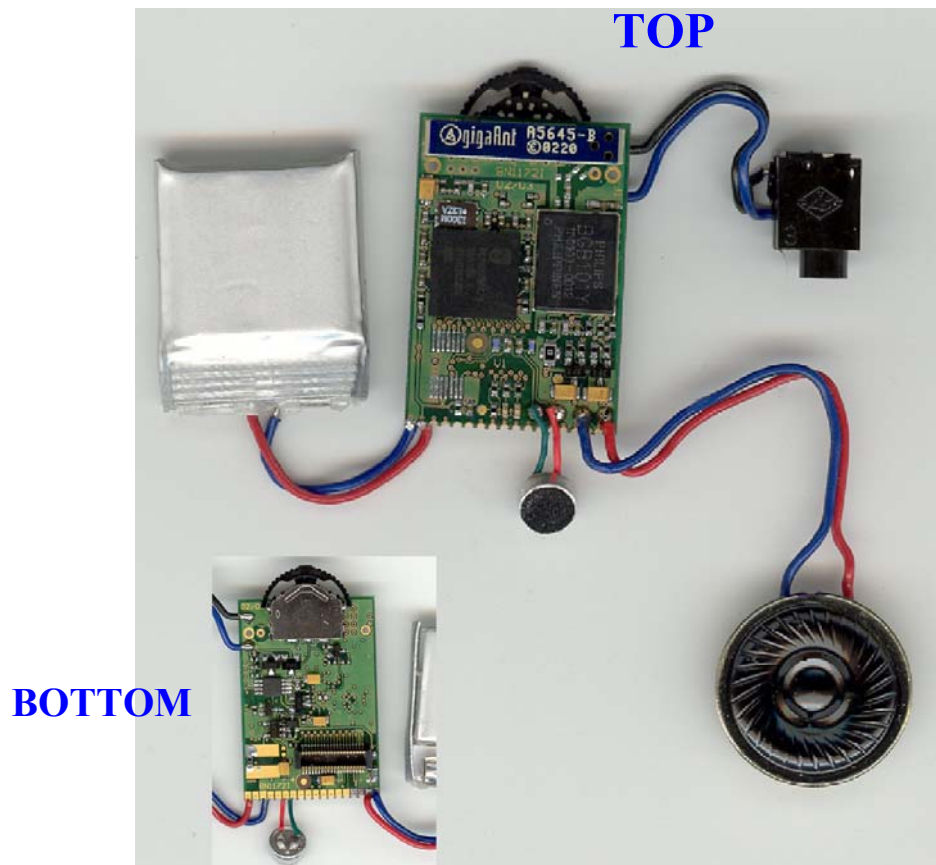

Picture 4. Sample connections – headset application.

6. Battery & charger:

Charging voltage:

External, 5V charging voltage is delivered to **J4** on bottom side of PCB.
Maximum current depends on used battery & onboard charger configuration.

Battery:

Any Lithium-polymer battery may be connected to **J3** on bottom side of PCB.
External resistor 10K or NTC overheating protecting thermistor must be connected to ground on **J3** to enable charger functionality.
For battery charging current setting information – please contact THB or read Microchip MCP73828 datasheet or Application notes..

Table 2. J1 - Pinout description:

1	Ground
2	Power supply, usually from lithium polymer battery.
3	Module RS232 TX signal. Default speed 19200 bps.
4	Module RS232 RX signal. Default speed 19200 bps.
5	Audio input signal -
6	Audio input signal +
7	Module Hardware Reset Input. Reset Active low.
8	VMIC – electret microphone 2 Volts supply voltage. Low voltage level when microphone Mute is active. Reference voltage for module tuning.
9	REF_CLK – 13 MHz reference clock signal. Used for module tuning procedure.
10	MFB/GPIO – Active low. The same functionality as 3 functional switch press.
11	MUTE – Microphone muting
12	Volume - - Speaker volume decrease.
13	Volume + - Speaker volume increase.
14	RED_LED - Output signal active to positive voltage.
15	GREEN_LED - Output signal active to negative voltage.
16	Ground
17	Speaker - Output to speaker, headphones etc.
18	Speaker + Output to speaker, headphones etc.

Addendum. J2 signals description.

J2 connector is designed specifically for connecting module to ANY other PCB, with minimum occupied space on host system. Connector provides access to all signals needed for development or ‘real life’ application. For detailed connector’s signals and functionality description please contact THB.