



FCC RF Test Report

APPLICANT : Getac Technology Corporation
EQUIPMENT : Tablet
BRAND NAME : Getac
MODEL NAME : Z710
MARKETING NAME : Z710
FCC ID : QYLZ710
STANDARD : FCC Part 15 Subpart C §15.247
CLASSIFICATION : (DTS) Digital Transmission System

The product was received on Jun. 20, 2012 and completely tested on Aug. 29, 2012. We, SPORTON INTERNATIONAL INC., would like to declare that the tested sample has been evaluated in accordance with the procedures and shown the compliance with the applicable technical standards.

The test results in this report apply exclusively to the tested model / sample. Without written approval of SPORTON INTERNATIONAL INC., the test report shall not be reproduced except in full.

Reviewed by:

Jones Tsai / Manager



SPORTON INTERNATIONAL INC.

No. 52, Hwa Ya 1st Rd., Hwa Ya Technology Park, Kwei-Shan Hsiang, Tao Yuan Hsien, Taiwan, R.O.C.



TABLE OF CONTENTS

REVISION HISTORY 3

SUMMARY OF TEST RESULT 4

1 GENERAL DESCRIPTION 5

 1.1 Applicant 5

 1.2 Manufacturer 5

 1.3 Feature of Equipment Under Test 5

 1.4 Testing Site 6

 1.5 Applied Standards 6

 1.6 Ancillary Equipment List 7

2 TEST CONFIGURATION OF EQUIPMENT UNDER TEST 8

 2.1 Carrier Frequency Channel 8

 2.2 Pre-Scanned RF Power 9

 2.3 Test Mode 10

 2.4 Connection Diagram of Test System 12

 2.5 RF Utility 16

3 TEST RESULT 17

 3.1 6dB Bandwidth Measurement 17

 3.2 Output Power Measurement 24

 3.3 Power Spectral Density Measurement 27

 3.4 Conducted Band Edges and Spurious Emission Measurement 34

 3.5 Radiated Emission Measurement 47

 3.6 AC Conducted Emission Measurement 70

 3.7 Antenna Requirements 74

4 LIST OF MEASURING EQUIPMENT 75

5 UNCERTAINTY OF EVALUATION 76

APPENDIX A. PHOTOGRAPHS OF EUT

APPENDIX B. SETUP PHOTOGRAPHS

SUMMARY OF TEST RESULT

Report Section	FCC Rule	IC Rule	Description	Limit	Result	Remark
3.1	15.247(a)(2)	A8.2(a)	6dB Bandwidth	$\geq 0.5\text{MHz}$	Pass	-
3.2	15.247(b)	A8.4	Power Output Measurement	$\leq 30\text{dBm}$	Pass	-
3.3	15.247(e)	A8.2(b)	Power Spectral Density	$\leq 8\text{dBm}/3\text{kHz}$	Pass	-
3.4	15.247(d)	A8.5	Conducted Band Edges	$\leq 20\text{dBc}$	Pass	-
			Conducted Spurious Emission		Pass	-
3.5	15.247(d)	A8.5	Radiated Band Edges	15.209(a) & 15.247(d)	Pass	Under limit 0.86 dB at 2483.540 MHz
			Radiated Spurious Emission		Pass	-
3.6	15.207	Gen 7.2.4	AC Conducted Emission	15.207(a)	Pass	Under limit 9.40 dB at 0.150 MHz
3.7	15.203 & 15.247(b)	A8.4	Antenna Requirement	N/A	Pass	-

1 General Description

1.1 Applicant

Getac Technology Corporation

5F., Building A, No. 209, Sec. 1, Nangang Rd., Nangang Dist., Taipei City 11568, Taiwan, R.O.C.

1.2 Manufacturer

Getac Technology (Kunshan) Co., LTD.

No. 269, No. 2 Avenue, Kunshan Comprehensive Free Trade Zone, Jiangsu Province, P.R.C.

1.3 Feature of Equipment Under Test

Product Feature	
Equipment	Tablet
Brand Name	Getac
Model Name	Z710
Marketing Name	Z710
FCC ID	QYLZ710
Integrated Module	Brand Name : Jorjin Model Name : WG7310
EUT supports Radios application	GSM/EGPRS/WCDMA/HSPA/ WLAN 11bgn / Bluetooth / RFID
HW Version	R0A
SW Version	G0.0621.09.MU2
EUT Stage	Production Unit

Remark: The above EUT's information was declared by manufacturer. Please refer to the specifications or user's manual for more detailed description.

Product Specification subjective to this standard	
Tx/Rx Frequency Range	2412 MHz ~ 2462 MHz
Number of Channels	11
Carrier Frequency of Each Channel	2412+(n-1)*5 MHz; n=1~11
Maximum Output Power to Antenna	802.11b : 18.12 dBm (0.0649 W) 802.11g : 24.33 dBm (0.2710 W) 802.11n HT20 : 24.07 dBm (0.2553 W)
Antenna Type	PIFA Antenna with gain 2.90 dBi
Type of Modulation	802.11b : DSSS (BPSK / QPSK / CCK) 802.11g/n : OFDM (BPSK / QPSK / 16QAM / 64QAM)

1.4 Testing Site

Test Site	SPORTON INTERNATIONAL INC.			
Test Site Location	No. 52, Hwa Ya 1 st Rd., Hwa Ya Technology Park, Kwei-Shan Hsiang, Tao Yuan Hsien, Taiwan, R.O.C. TEL: +886-3-3273456 / FAX: +886-3-3284978			
Test Site No.	Sporton Site No.			FCC/IC Registration No.
	TH02-HY	CO05-HY	03CH05-HY	722060/4086B-1

1.5 Applied Standards

According to the specifications of the manufacturer, the EUT must comply with the requirements of the following standards:

- ♦ FCC Part 15 Subpart C §15.247
- ♦ FCC KDB Publication No. 558074 D01 DTS Meas. Guidance v01
- ♦ FCC TCB Workshop 2012, April
- ♦ ANSI C63.4-2003 and ANSI C63.10-2009
- ♦ IC RSS-210 Issue 8
- ♦ IC RSS-Gen Issue 3

Remark:

1. All test items were verified and recorded according to the standards and without any deviation during the test.
2. This EUT has also been tested and complied with the requirements of FCC Part 15, Subpart B, recorded in a separate test report.



1.6 Ancillary Equipment List

Item	Equipment	Trade Name	Model Name	FCC ID	Data Cable	Power Cord
1.	System Simulator	R&S	CMU 200	N/A	N/A	Unshielded, 1.8 m
2.	WLAN AP	D-Link	DIR-628	KA2DIR628A2	N/A	Unshielded, 1.8 m
3.	Car Battery	YUASA	46B24R(S)	N/A	N/A	N/A
4.	Notebook	DELL	Vostro 1510	FCC DoC	N/A	AC I/P: Unshielded, 1.2 m DC O/P: Shielded, 1.8 m
5.	LCD Monitor	Dell	U2410	FCC DoC	Shielded, 1.6 m	Unshielded, 1.8 m
6.	Bluetooth Earphone	Sony Ericsson	MW600	PY7DDA-2029	N/A	N/A
7.	Earphone	Ergotech	ET-E200	FCC DoC	Unshielded, 1.8 m	N/A
8.	USB3.0 HD	WD	WDBAAR5000A BK-PESN	FCC DoC	Unshielded, 0.5 m	N/A
9.	(USB) Mouse	DELL	MOC5UO	FCC DoC	Shielded, 1.8 m	N/A
10.	iPod	Apple	A1285	FCC DoC	Shielded, 1.0 m	N/A
11.	iPod Earphone	Apple	N/A	FCC DoC	Unshielded, 1.0 m	N/A

2 Test Configuration of Equipment Under Test

The EUT has been associated with peripherals and configuration operated in a manner tended to maximize its emission characteristics in a typical application. Frequency range investigated: conducted emission (150 KHz to 30 MHz) and radiated emission (9 KHz to the 10th harmonic of the highest fundamental frequency or to 40 GHz, whichever is lower). For radiated measurement, pre-scanned in three orthogonal panels, X, Y, Z. The worst cases (X plane) were recorded in this report.

The final configuration from all the combinations and the worst-case data rates were investigated by measuring the maximum power across all the data rates and modulation modes under section 2.2.

Based on the worst configuration found above, the RF power setting is set individually to meet FCC compliance limit for the final conducted and radiated tests shown in section 2.3.

2.1 Carrier Frequency Channel

Frequency Band	Channel	Freq. (MHz)	Channel	Freq. (MHz)
2400-2483.5 MHz	1	2412	7	2442
	2	2417	8	2447
	3	2422	9	2452
	4	2427	10	2457
	5	2432	11	2462
	6	2437		



2.2 Pre-Scanned RF Power

Preliminary tests were performed in different data rate and antenna configurations as following table and the highest power data rates were chosen for full test in the following tables. Final Output Power equals to Measured Output Power adds the duty factor.

2.4GHz 802.11b mode				
Data Rate (MHz)	1M bps	2M bps	5.5M bps	11M bps
Peak Power (dBm)	18.12	18.12	17.79	17.79

2.4GHz 802.11g mode								
Data Rate (MHz)	6M bps	9M bps	12M bps	18M bps	24M bps	36M bps	48M bps	54M bps
Peak Power (dBm)	24.33	24.28	24.27	24.25	24.17	24.22	23.75	23.64

2.4GHz 802.11n HT20 mode								
Data Rate (MHz)	MCS0	MCS1	MCS2	MCS3	MCS4	MCS5	MCS6	MCS7
Peak Power (dBm)	24.07	23.74	23.76	23.70	23.62	23.17	23.19	22.60

2.3 Test Mode

Final results of test modes, data rates and test channels are shown as following table.

Test Cases					
	Test Items	Mode	Data Rate	Test Channel	Remark
Conducted TCs	6dB and 99% BW Power Spectral Density	802.11b	1 Mbps	1/6/11	-
		802.11g	6 Mbps	1/6/11	-
		802.11n HT20	6.5 Mbps	1/6/11	-
	Output Power	802.11b	1 Mbps	1/6/11	-
		802.11g	6 Mbps	1/6/11	-
		802.11n HT20	6.5 Mbps	1/6/11	-
	Conducted Band EDGE	802.11b	1 Mbps	1/11	-
		802.11g	6 Mbps	1/11	-
		802.11n HT20	6.5 Mbps	1/11	-
	Conducted Spurious Emission	802.11b	1 Mbps	1/6/11	-
		802.11g	6 Mbps	1/6/11	-
		802.11n HT20	6.5 Mbps	1/6/11	-
Radiated TCs	Radiated Band EDGE	802.11b	1 Mbps	1/11	<Fig. 1>
		802.11g	6 Mbps	1/11	<Fig. 1>
		802.11g	6 Mbps	11	<Fig. 2>
		802.11g	6 Mbps	11	<Fig. 3>
		802.11n HT20	6.5 Mbps	1/11	<Fig. 1>
	Radiated Spurious Emission	802.11b	1 Mbps	1/6/11	<Fig. 1>
		802.11g	6 Mbps	1/6/11	<Fig. 1>
		802.11g	6 Mbps	11	<Fig. 2>
		802.11g	6 Mbps	11	<Fig. 3>
		802.11n HT20	6.5 Mbps	1/6/11	<Fig. 1>

Test Cases	
AC Conducted Emission	Mode 1 :RFID On + TC1 <Fig. 4> Mode 2 :WCDMA Band II Idle + WLAN Link + Bluetooth Link + RFID On + Camera + TC2 <Fig. 5> Mode 3 :GSM1900 (GPRS 8) Idle + WLAN Link + Bluetooth Link + RFID On + MPEG4 + TC3 <Fig. 6> Mode 4 :GSM1900 (GPRS 8) Idle + WLAN Link + Bluetooth Link + RFID On + MPEG4 + TC4 <Fig. 7> Mode 5 :GSM1900 (GPRS 8) Idle + RFID On + MPEG4 + TC5 <Fig. 8> Mode 6 :WLAN Link + Bluetooth Link + Camera + TC2 <Fig. 9>
Remark:	
<ol style="list-style-type: none"> 1. TC1 stands for Test Configuration, and consists of USB Cable (Data Link with Notebook), Adapter 1, SD Card, and USB 3.0 HD. 2. TC2 stands for Test Configuration, and consists of SD Card, HDMI Cable, earphone, docking 1, RJ-45 Load, USB Cable (Link with Notebook), mouse, USB 3.0 HD, and adapter 2. 3. TC3 stands for Test Configuration, and consists of SD Card, HDMI Cable, earphone, docking 1, RJ-45 Link, USB Cable (Load with Notebook), mouse, USB 3.0 HD, and adapter 2. 4. TC4 stands for Test Configuration, and consists of SD Card, HDMI Cable, earphone, docking 2, RJ-45 Load, RS-232 Load, mouse, USB 3.0 HD, and car charger (12V). 5. TC5 stands for Test Configuration, and consists of SD Card, HDMI Cable, earphone, docking 2, RJ-45 Link, RS-232 Load, USB Load, mouse, USB 3.0 HD, and car charger (24V). 6. The worst case of conducted emission is mode 3; only the test data of it was reported. 	

2.4 Connection Diagram of Test System

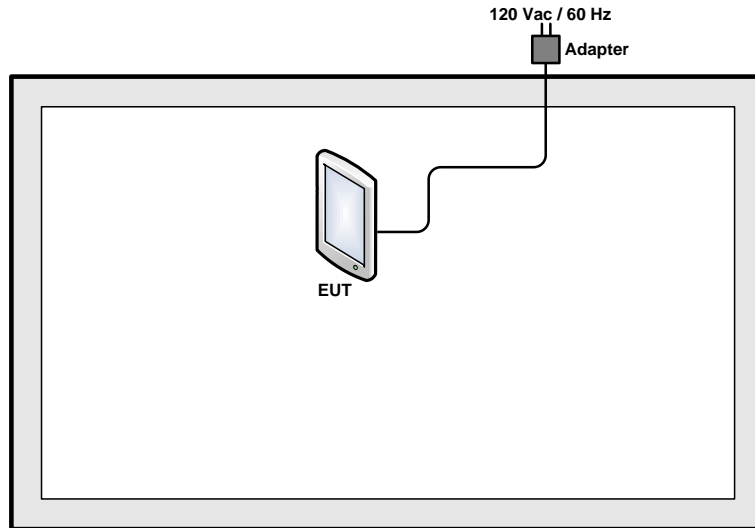

<Fig. 1>

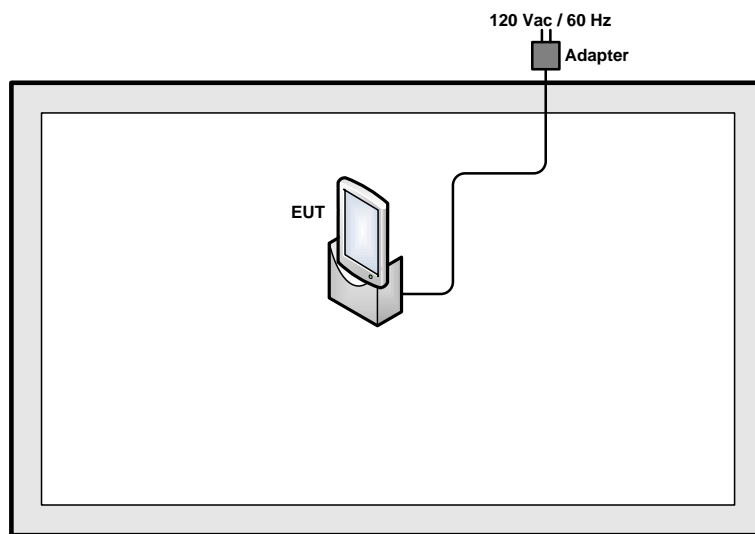

<Fig. 2>

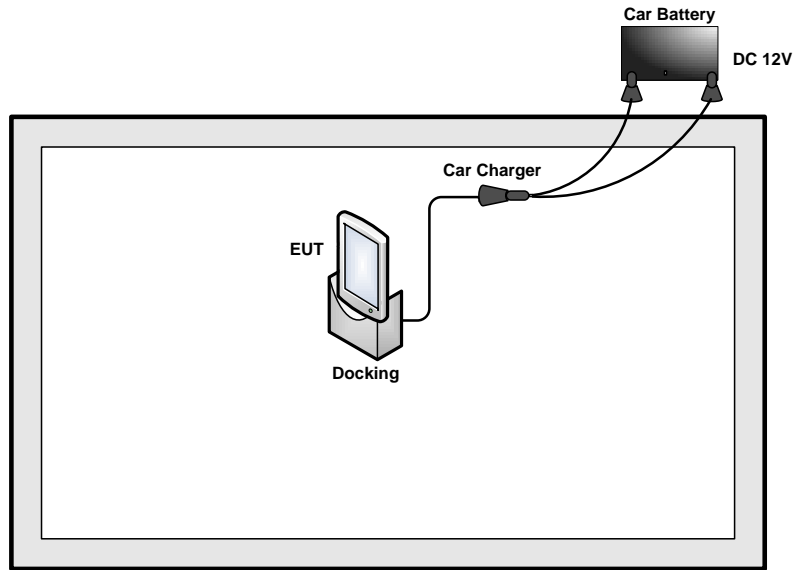

<Fig. 3>

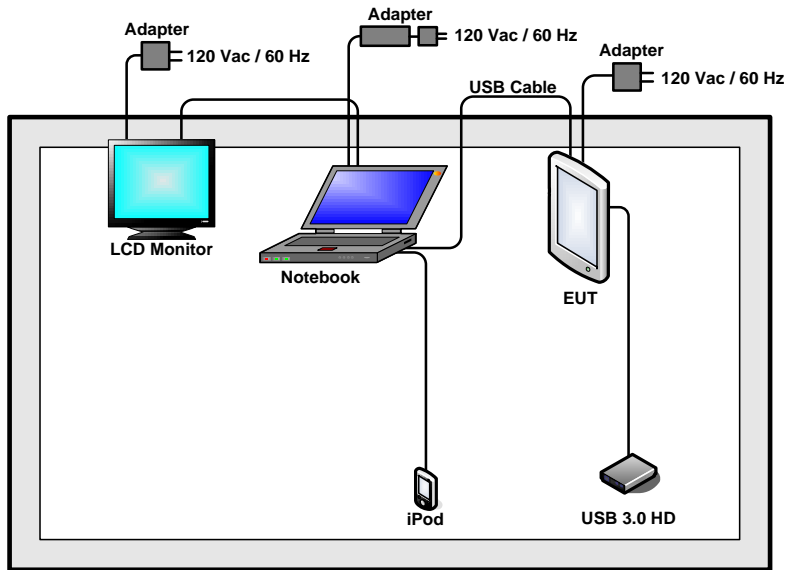

<Fig. 4>

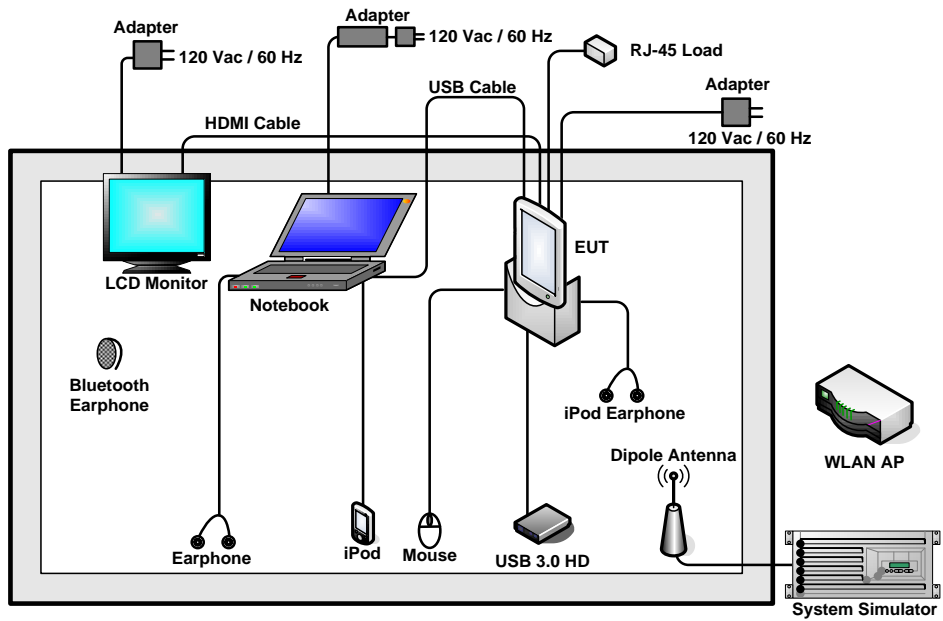

<Fig. 5>

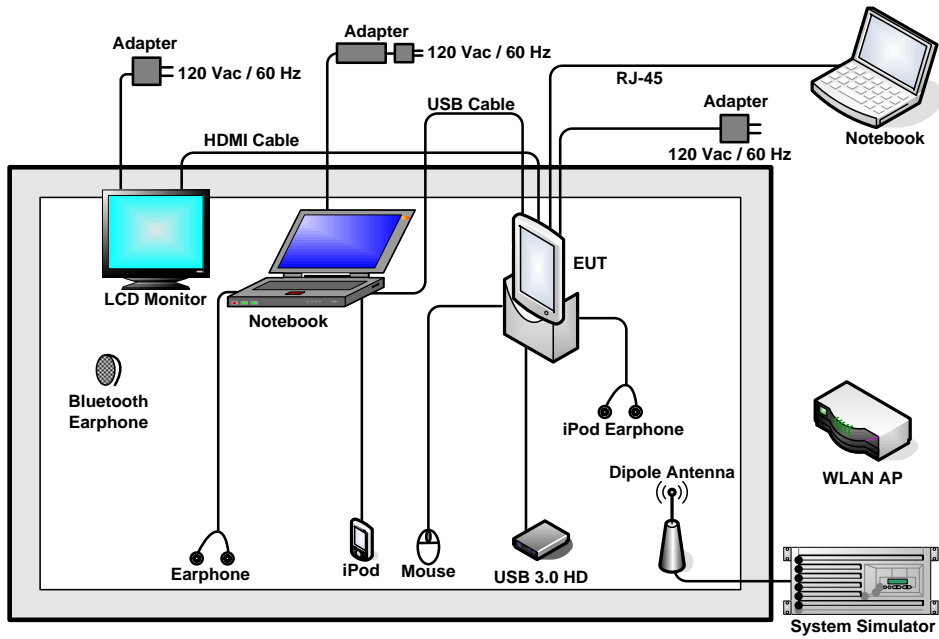

<Fig. 6>

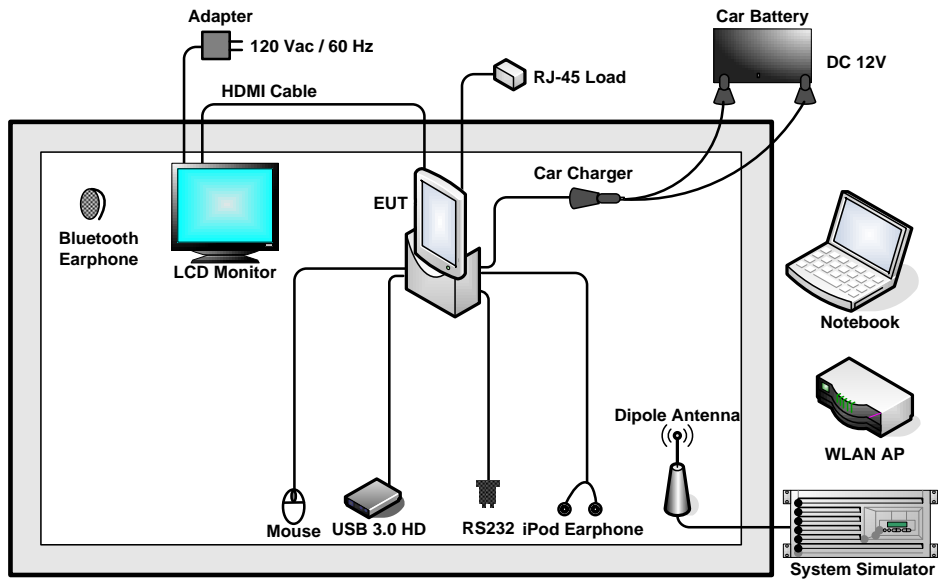

<Fig. 7>

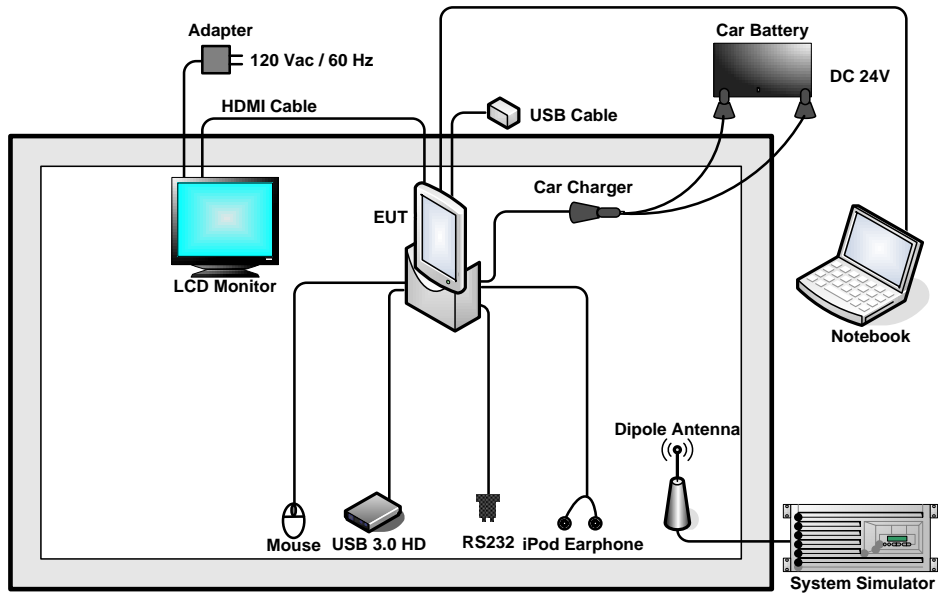

<Fig. 8>

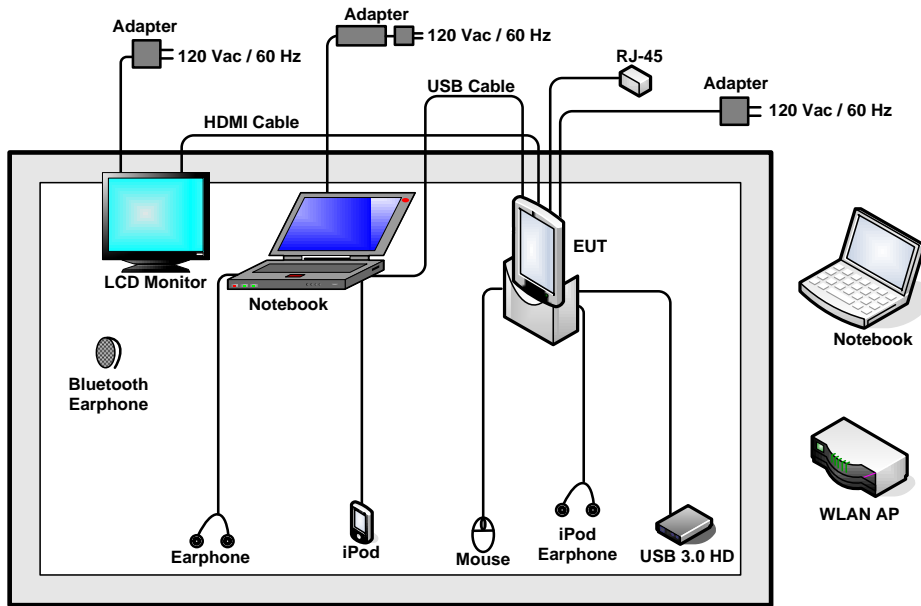

<Fig. 9>

2.5 RF Utility

The programmed RF utility “Z710_WiFi TestTool” is installed in EUT to provide channel selection, power level, data rate and the application type. RF Utility can send transmitting signal for all testing. The RF output power selection is for the setting of RF output power expected by the customer and is going to be fixed on the firmware of the final end product.

3 Test Result

3.1 6dB Bandwidth Measurement

3.1.1 Limit of 6dB Bandwidth

The minimum 6 dB bandwidth shall be at least 500 KHz.

3.1.2 Measuring Instruments

See list of measuring instruments of this test report.

3.1.3 Test Procedures

1. The testing follows FCC KDB Publication No. 558074 D01 DTS Meas. Guidance and TCB Workshop 2012, April.
2. The RF output of EUT was connected to the spectrum analyzer by a low loss cable. The path loss was compensated to the results for each measurement.
3. Set to the maximum power setting and enable the EUT transmit continuously.
4. Make the measurement with the spectrum analyzer's resolution bandwidth (RBW) = 1-5% of the emission bandwidth (EBW). Set the Video bandwidth (VBW) $\geq 3 * RBW$. In order to make an accurate measurement. The 6 dB bandwidth must be greater than 500 KHz.

3.1.4 Test Setup

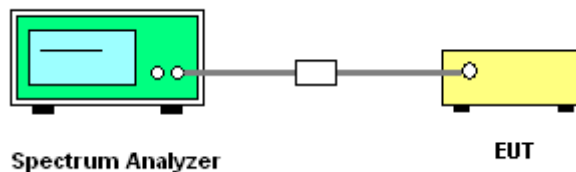



3.1.5 Test Result of 6dB Bandwidth

Test Mode :	802.11b	Temperature :	24~26°C
Test Engineer :	Book Lin	Relative Humidity :	50~53%

Channel	Frequency (MHz)	802.11b 6dB Bandwidth (MHz)	6dB Bandwidth Min. Limit (MHz)	Pass/Fail
01	2412	9.16	0.5	Pass
06	2437	9.16	0.5	Pass
11	2462	9.16	0.5	Pass

6 dB Bandwidth Plot on 802.11b Channel 01

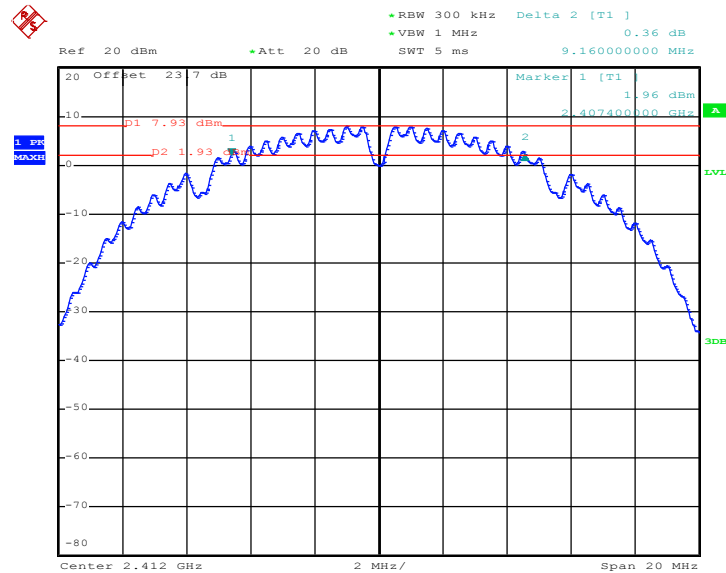

Date: 20.AUG.2012 20:58:42



6 dB Bandwidth Plot on 802.11b Channel 06

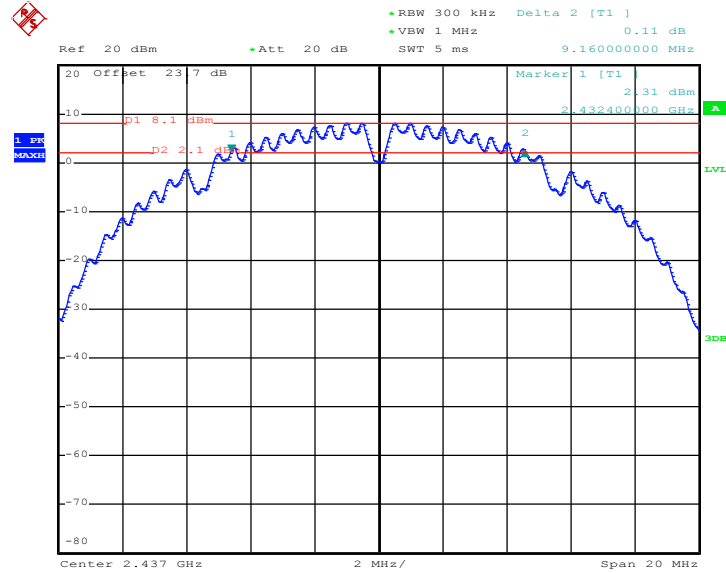

Date: 20.AUG.2012 21:02:17

6 dB Bandwidth Plot on 802.11b Channel 11

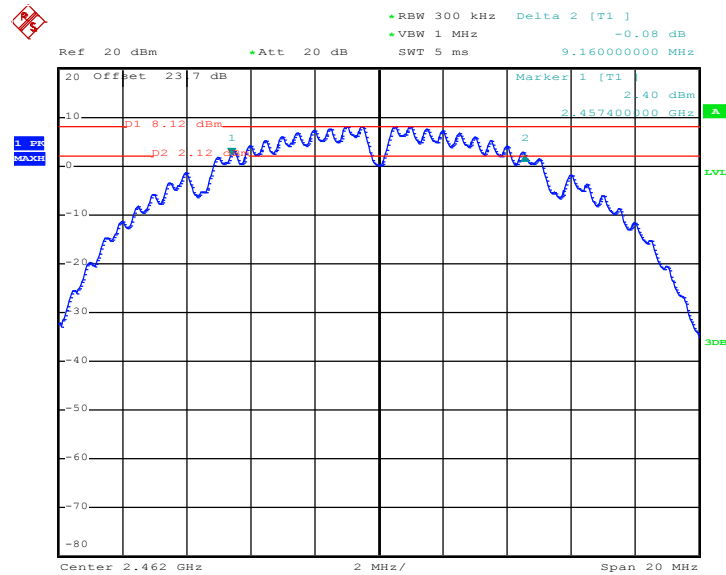

Date: 20.AUG.2012 21:05:56



Test Mode :	802.11g	Temperature :	24~26°C
Test Engineer :	Book Lin	Relative Humidity :	50~53%

Channel	Frequency (MHz)	802.11g 6dB Bandwidth (MHz)	6dB Bandwidth Min. Limit (MHz)	Pass/Fail
01	2412	16.08	0.5	Pass
06	2437	16.08	0.5	Pass
11	2462	16.08	0.5	Pass

6 dB Bandwidth Plot on 802.11g Channel 01

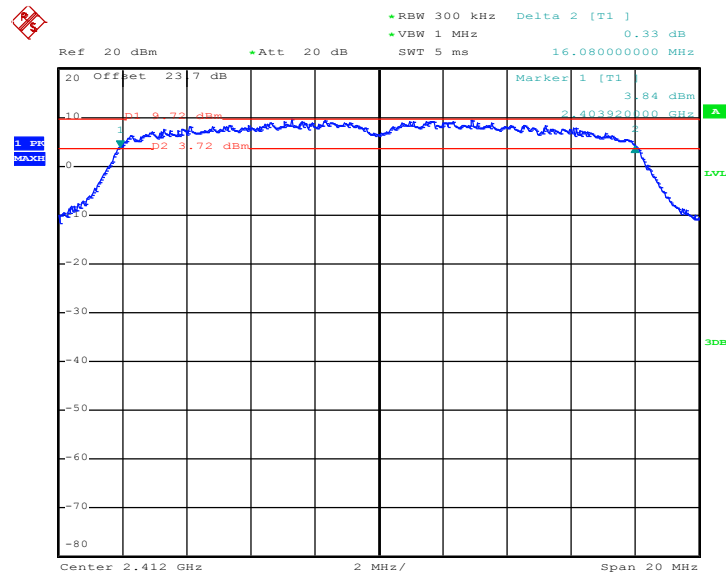

Date: 20.AUG.2012 21:17:39



6 dB Bandwidth Plot on 802.11g Channel 06

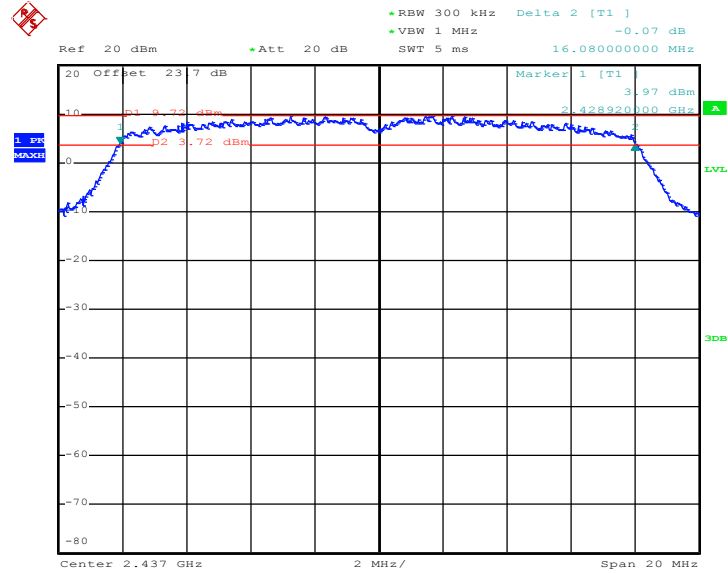

Date: 20.AUG.2012 21:14:17

6 dB Bandwidth Plot on 802.11g Channel 11

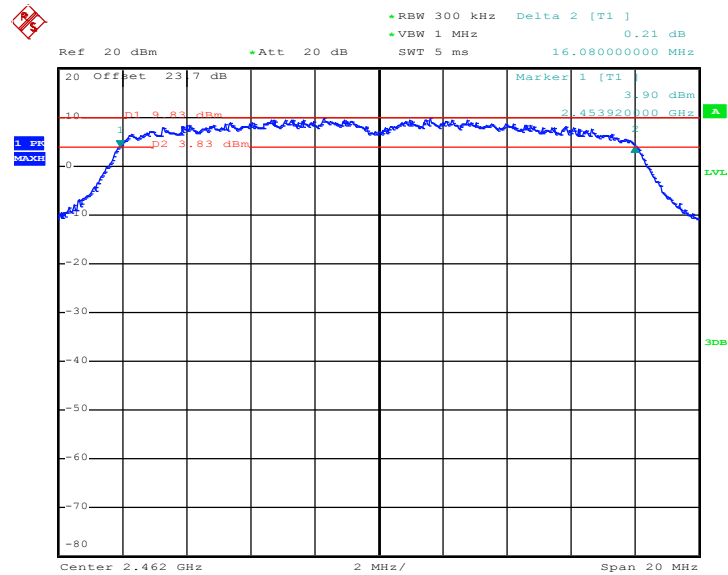

Date: 20.AUG.2012 21:10:00



Test Mode :	802.11n HT20	Temperature :	24~26°C
Test Engineer :	Book Lin	Relative Humidity :	50~53%

Channel	Frequency (MHz)	2.4GHz 802.11n HT20 6dB Bandwidth (MHz)	6dB Bandwidth Min. Limit (MHz)	Pass/Fail
01	2412	17.26	0.5	Pass
06	2437	17.32	0.5	Pass
11	2462	17.20	0.5	Pass

6 dB Bandwidth Plot on 802.11n HT20 Channel 01

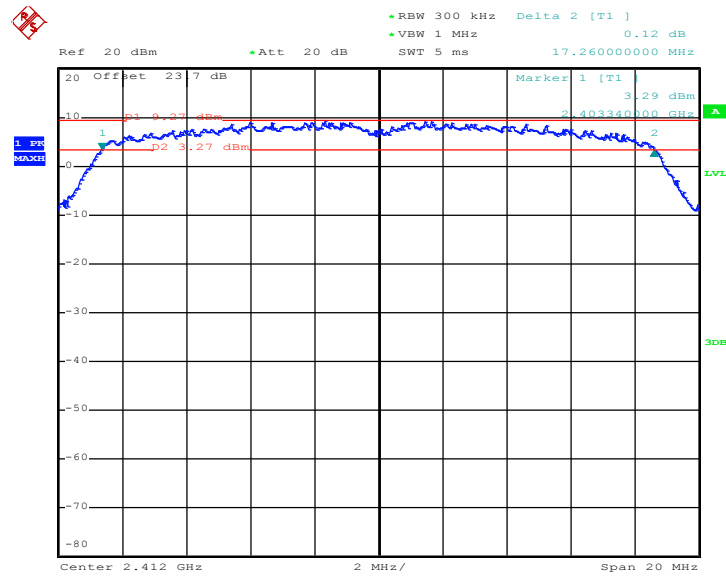

Date: 20.AUG.2012 21:23:19



6 dB Bandwidth Plot on 802.11n HT20 Channel 06

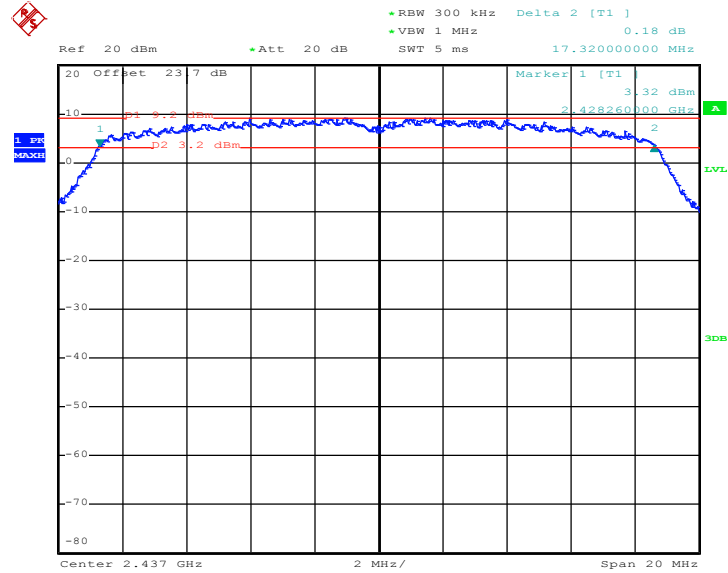

Date: 20.AUG.2012 21:27:13

6 dB Bandwidth Plot on 802.11n HT20 Channel 11

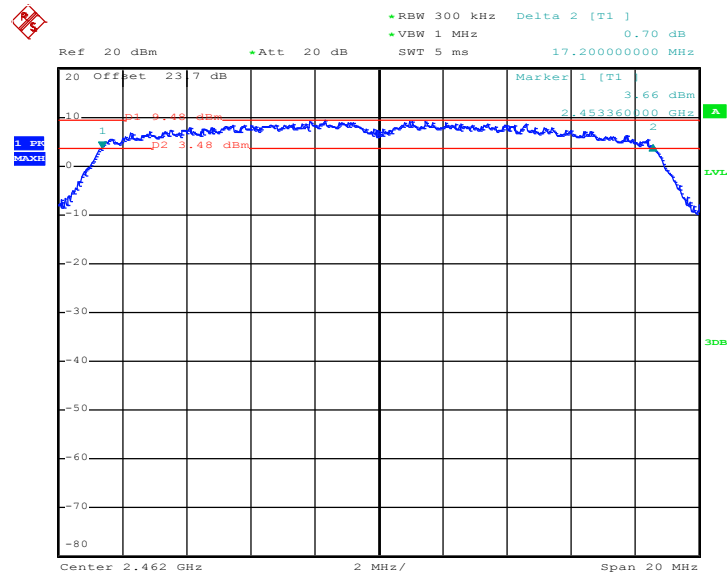

Date: 20.AUG.2012 21:30:12

3.2 Output Power Measurement

3.2.1 Limit of Output Power

For systems using digital modulation in the 2400-2483.5MHz, the limit for peak output power is 30dBm. If transmitting antenna of directional gain greater than 6dBi are used the peak output power from the intentional radiator shall be reduced below the above stated value by the amount in dB that the directional gain of the antenna exceeds 6 dBi. In case of point-to-point operation, the limit has to be reduced by 1dB for every 3dB that the directional gain of the antenna exceeds 6dBi.

3.2.2 Measuring Instruments

See list of measuring instruments of this test report.

3.2.3 Test Procedures

1. The testing follows the Measurement Procedure 7.2.1.3 Option 3(peak power meter method) of FCC KDB No. 558074 DTS Meas. Guidance DR01.
2. The RF output of EUT was connected to the power meter by a low loss cable
3. Set to the maximum power setting and enable the EUT transmit continuously.
4. Measure the conducted output power and record the results in the test report.

3.2.4 Test Setup

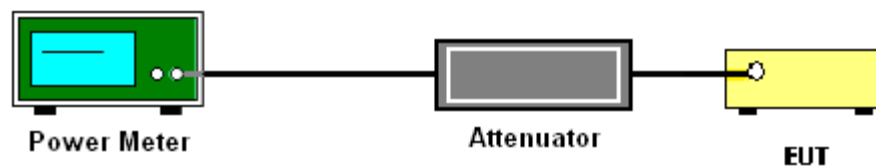

3.2.5 Test Result of Peak Output Power

Test Mode :	802.11b	Temperature :	24~26°C
Test Engineer :	Book Lin	Relative Humidity :	50~53%

Channel	Frequency (MHz)	802.11b Peak Output Power (dBm)	Max. Limits (dBm)	Pass/Fail
01	2412	18.12	30	Pass
06	2437	18.08	30	Pass
11	2462	17.96	30	Pass

Test Mode :	802.11g	Temperature :	24~26°C
Test Engineer :	Book Lin	Relative Humidity :	50~53%

Channel	Frequency (MHz)	802.11g Peak Output Power (dBm)	Max. Limits (dBm)	Pass/Fail
01	2412	23.58	30	Pass
06	2437	24.33	30	Pass
11	2462	23.80	30	Pass

Test Mode :	802.11n HT20	Temperature :	24~26°C
Test Engineer :	Book Lin	Relative Humidity :	50~53%

Channel	Frequency (MHz)	2.4GHz 802.11n HT20 Peak Output Power (dBm)	Max. Limits (dBm)	Pass/Fail
01	2412	23.37	30	Pass
06	2437	24.07	30	Pass
11	2462	23.46	30	Pass



3.2.6 Test Result of Average output Power (Reporting Only)

Test Mode :	802.11b	Temperature :	24~26
Test Engineer :	Book Lin	Relative Humidity :	50~53
Duty Cycle:	100.00%	Duty Factor:	0.00dB

Channel	Frequency (MHz)	802.11b Average Output Power (dBm)
01	2412	15.85
06	2437	15.82
11	2462	15.71

Test Mode :	802.11g	Temperature :	24~26
Test Engineer :	Book Lin	Relative Humidity :	50~53
Duty Cycle:	97.73%	Duty Factor:	0.10dB

Channel	Frequency (MHz)	802.11g Average Output Power (dBm)
01	2412	15.55
06	2437	16.87
11	2462	15.08

Test Mode :	802.11n HT20	Temperature :	24~26
Test Engineer :	Book Lin	Relative Humidity :	50~53
Duty Cycle:	97.76%	Duty Factor:	0.10dB

Channel	Frequency (MHz)	802.11n HT20 Average Output Power (dBm)
01	2412	14.46
06	2437	16.52
11	2462	13.91

3.3 Power Spectral Density Measurement

3.3.1 Limit of Power Spectral Density

The peak power spectral density shall not be greater than 8dBm in any 3KHz band at any time interval of continuous transmission.

3.3.2 Measuring Instruments

See list of measuring instruments of this test report.

3.3.3 Test Procedures

1. The testing follows Measurement Procedure 5.3.1 (Peak PSD) of FCC KDB Publication No. 558074 D01 DTS Meas. Guidance and TCB Workshop 2012, April.
2. The RF output of EUT was connected to the spectrum analyzer by a low loss cable. The path loss was compensated to the results for each measurement.
3. Set to the maximum power setting and enable the EUT transmit continuously.
4. Make the measurement with the spectrum analyzer's resolution bandwidth (RBW) = 100 KHz. Video bandwidth (VBW) \geq 300 KHz In order to make an accurate measurement, set the span to 5-30% greater than Emission Bandwidth (EBW)
5. Detector = peak, Sweep time = auto couple, Trace mode = max hold, Allow trace to fully stabilize. Use the peak marker function to determine the maximum power level in any 100 kHz band segment within the fundamental EBW.
6. Record the measurement data derived from spectrum analyzer.
7. Scale the observed power level to an equivalent value in 3 kHz by adjusting (reducing) the measured power by a bandwidth correction factor (BWCF) where $BWCF = 10\log(3 \text{ kHz}/100 \text{ kHz} = -15.2 \text{ dB})$.

3.3.4 Test Setup

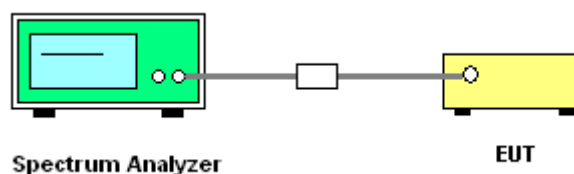

3.3.5 Test Result of Power Spectral Density

Test Mode :	802.11b	Temperature :	24~26°C
Test Engineer :	Book Lin	Relative Humidity :	50~53%

Channel	Frequency (MHz)	802.11b Power Density		Max. Limits (dBm)	Pass/Fail
		Measured PSD/100KHz (dBm)	PSD/3KHz (dBm)		
01	2412	7.50	-7.70	8	Pass
06	2437	7.56	-7.64	8	Pass
11	2462	7.47	-7.73	8	Pass

Note:

1. Measured power density (dBm) has offset with cable loss.
2. BWCF (dB) = $10 \log (3k/100k) = -15.2 \text{ dB}$
3. Power Density/ 3kHz (dBm) = Measured power density/ 100KHz (dBm) + BWCF (dB)

PSD Plot on 802.11b Channel 01

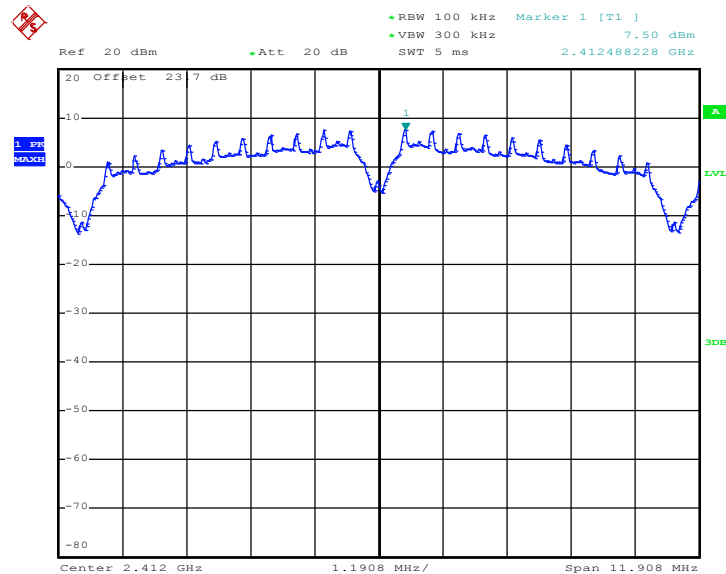

Date: 20.AUG.2012 20:59:12



PSD Plot on 802.11b Channel 06

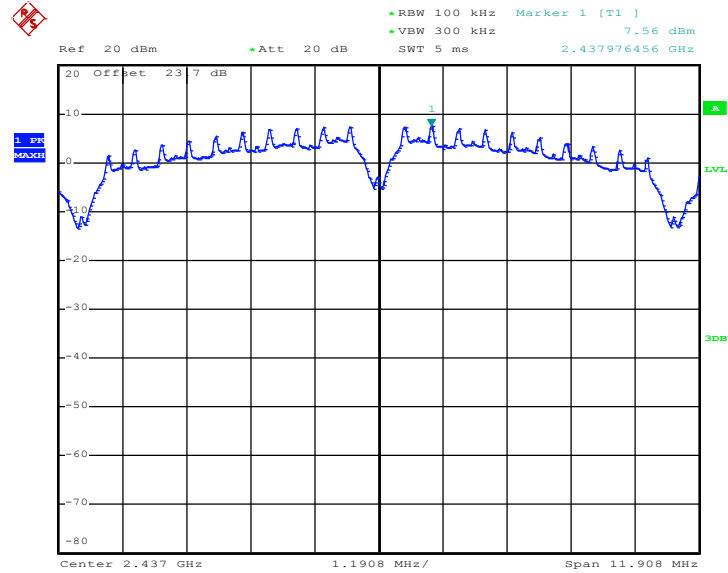

Date: 20.AUG.2012 21:02:51

PSD Plot on 802.11b Channel 11

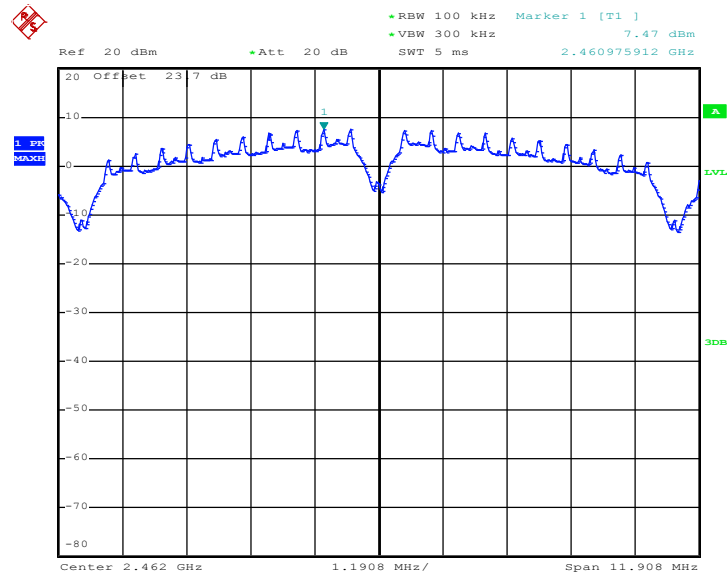

Date: 20.AUG.2012 21:06:29



Test Mode :	802.11g	Temperature :	24~26°C
Test Engineer :	Book Lin	Relative Humidity :	50~53%

Channel	Frequency (MHz)	802.11g Power Density		Max. Limits (dBm)	Pass/Fail
		Measured PSD/100KHz (dBm)	PSD/3KHz (dBm)		
01	2412	5.98	-9.22	8	Pass
06	2437	6.09	-9.11	8	Pass
11	2462	6.11	-9.09	8	Pass

Note:

- 1. Measured power density (dBm) has offset with cable loss.
- 2. BWCF (dB) = $10 \log (3k/100k) = -15.2 \text{ dB}$
- 3. Power Density/ 3KHz (dBm) = Measured power density/ 100KHz (dBm) + BWCF (dB)

PSD Plot on 802.11g Channel 01

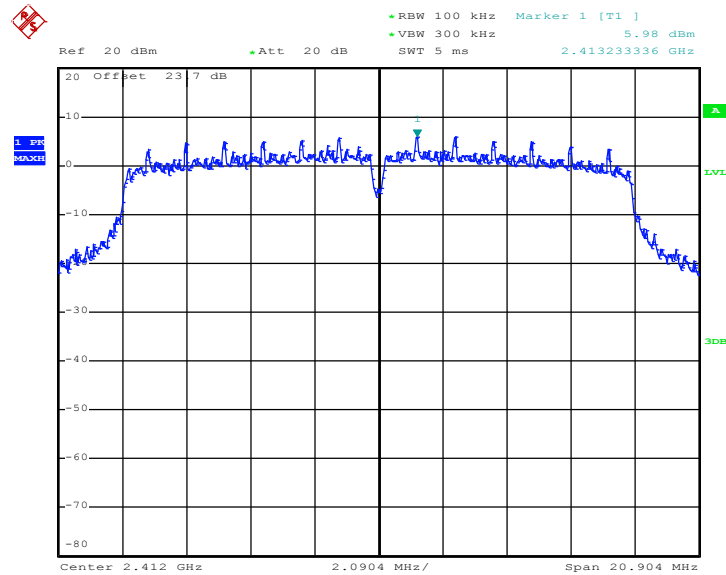

Date: 20.AUG.2012 21:18:04



PSD Plot on 802.11g Channel 06

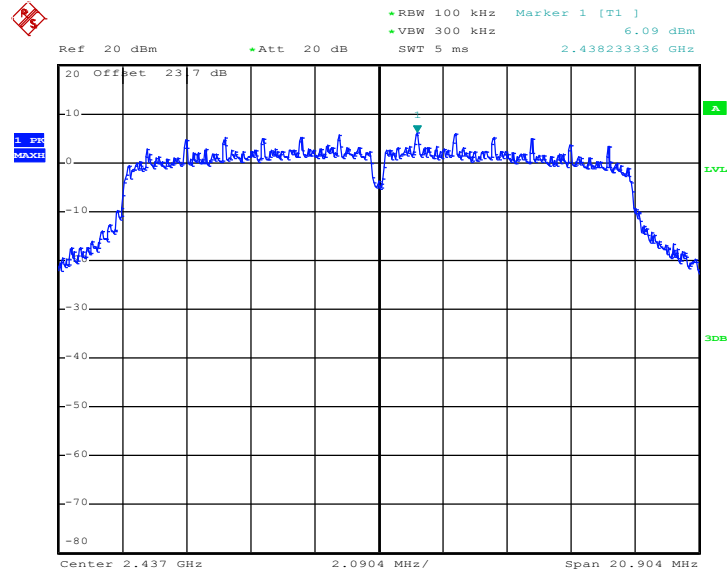

Date: 20.AUG.2012 21:14:54

PSD Plot on 802.11g Channel 11

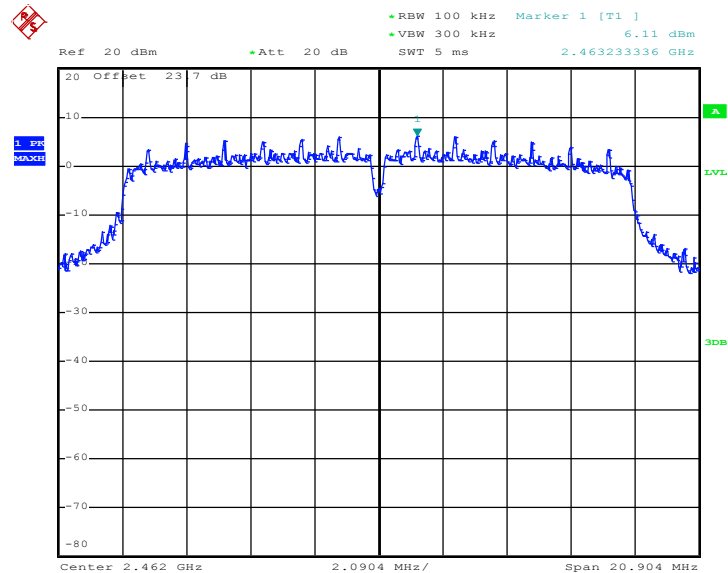

Date: 20.AUG.2012 21:10:42



Test Mode :	802.11n HT20	Temperature :	24~26°C
Test Engineer :	Book Lin	Relative Humidity :	50~53%

Channel	Frequency (MHz)	802.11n HT20 Power Density		Max. Limits (dBm)	Pass/Fail
		Measured PSD/100KHz (dBm)	PSD/3KHz (dBm)		
01	2412	6.03	-9.17	8	Pass
06	2437	6.13	-9.07	8	Pass
11	2462	5.99	-9.21	8	Pass

Note:

1. Measured power density (dBm) has offset with cable loss.
2. BWCF (dB) = $10 \log (3k/100k) = -15.2 \text{ dB}$
3. Power Density/ 3KHz (dBm)= Measured power density/ 100KHz (dBm) + BWCF (dB)

PSD Plot on 802.11n HT20 Channel 01

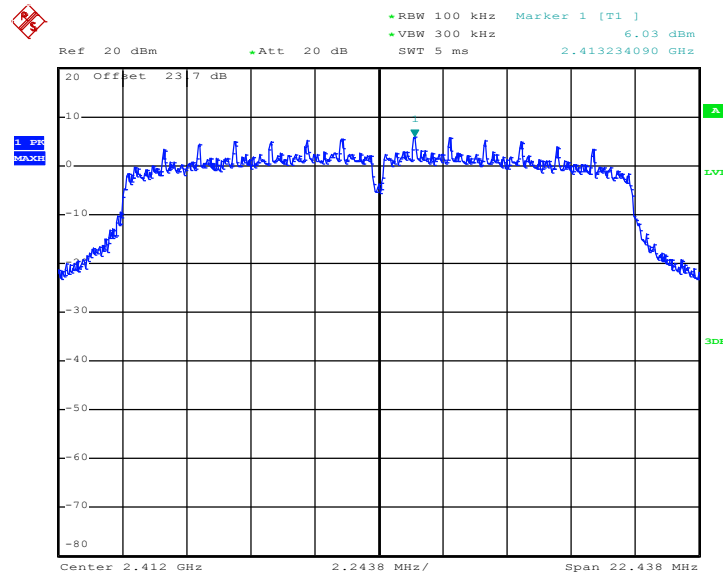

Date: 20.AUG.2012 21:23:55



PSD Plot on 802.11n HT20 Channel 06

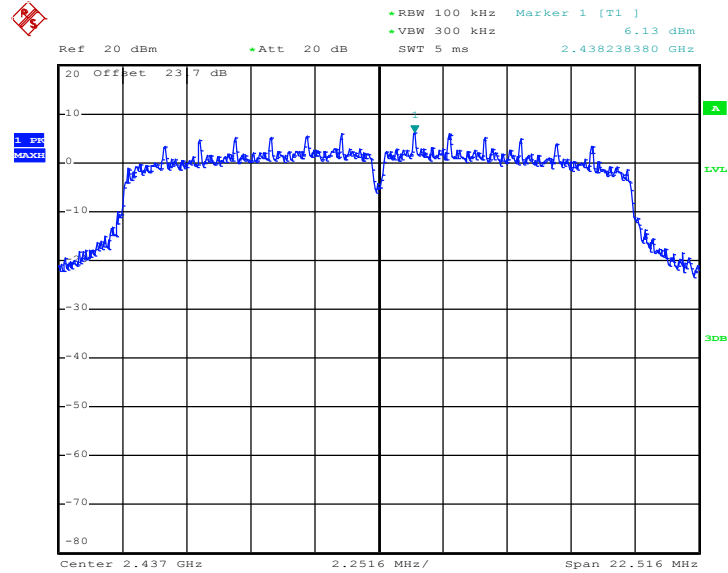

Date: 20.AUG.2012 21:27:36

PSD Plot on 802.11n HT20 Channel 11

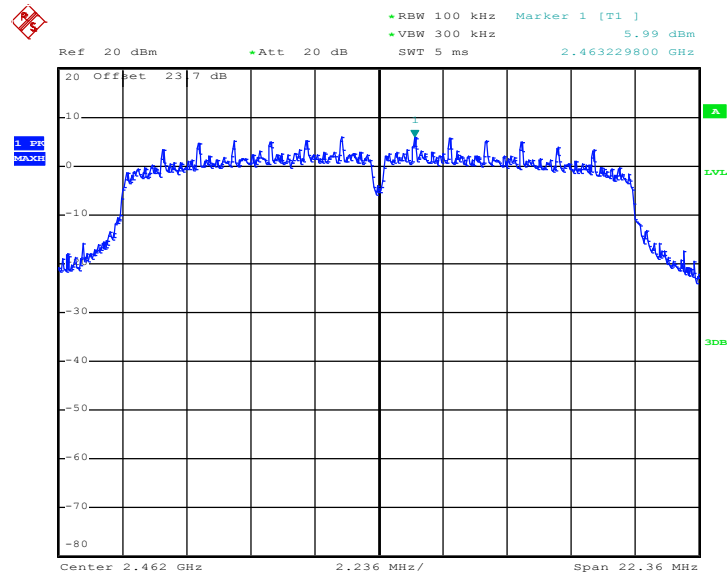

Date: 20.AUG.2012 21:30:37

3.4 Conducted Band Edges and Spurious Emission Measurement

3.4.1 Limit of Conducted Band Edges and Spurious Emission Measurement

In any 100 kHz bandwidth outside of the authorized frequency band, the emissions which fall in the non-restricted bands shall be attenuated at least 20 dB / 30dB relative to the maximum PSD level in 100 kHz by RF conducted measurement and radiated emissions which fall in the restricted bands, as defined in Section 15.205(a), must also comply with the radiated emission limits specified in Section 15.209(a).

3.4.2 Measuring Instruments

See list of measuring instruments of this test report.

3.4.3 Test Procedures

1. The testing follows the guidelines in the Measurement Procedure of FCC KDB Publication No. 558074 D01 DTS Meas. Guidance and TCB Workshop 2012, April.
2. Set to the maximum power setting and enable the EUT transmit continuously.
3. Set RBW = 100 KHz, VBW=300 KHz, Peak Detector. Unwanted Emissions measured in any 100 kHz bandwidth outside of the authorized frequency band shall be attenuated by at least 20 dB relative to the maximum in-band peak PSD level in 100 kHz, when maximum peak conducted output power procedure is used. The attenuation is set to 30dB, when maximum conducted output power procedure is used.
4. Measure and record the results in the test report.

3.4.4 Test Setup

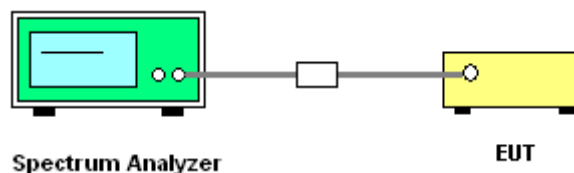



3.4.5 Test Plots of Conducted Band Edges

Test Mode :	802.11b	Temperature :	24~26°C
Test Band :	Low and High	Relative Humidity :	50~53%
Test Channel :	01 and 11	Test Engineer :	Book Lin

Low Band Edge Plot on 802.11b Channel 01

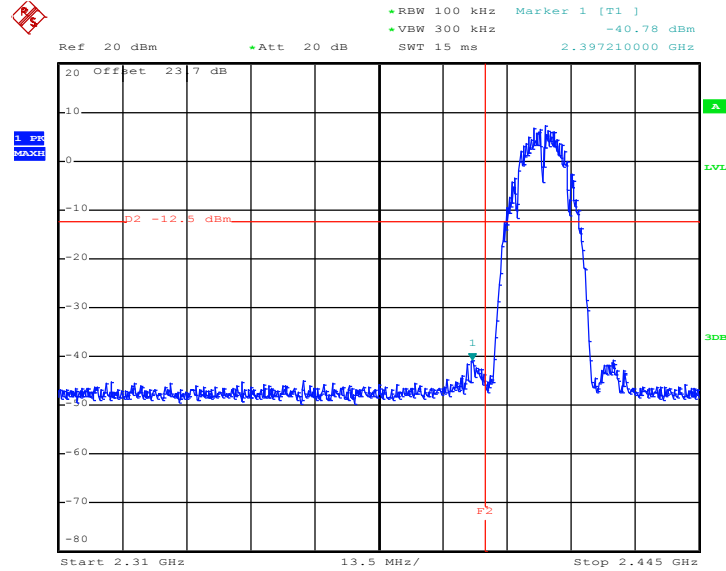

Date: 20.AUG.2012 20:59:43

High Band Edge Plot on 802.11b Channel 11

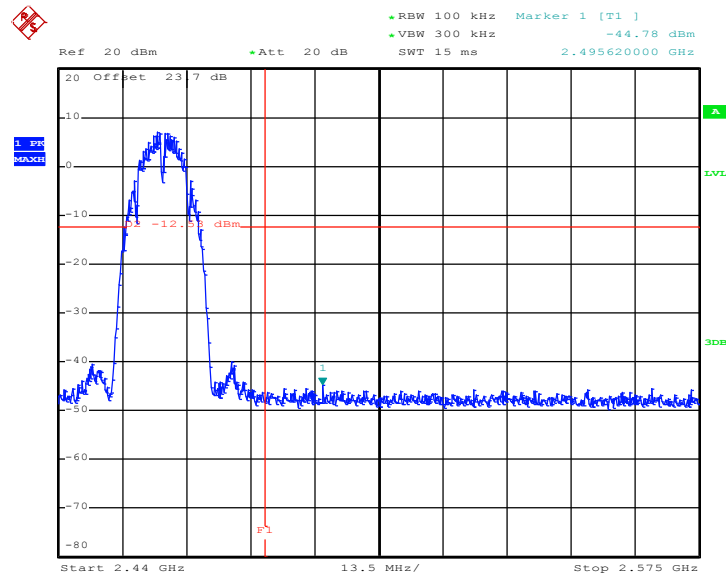

Date: 20.AUG.2012 21:06:48



Test Mode :	802.11g	Temperature :	24~26°C
Test Band :	Low and High	Relative Humidity :	50~53%
Test Channel :	01 and 11	Test Engineer :	Book Lin

Low Band Edge Plot on 802.11g Channel 01

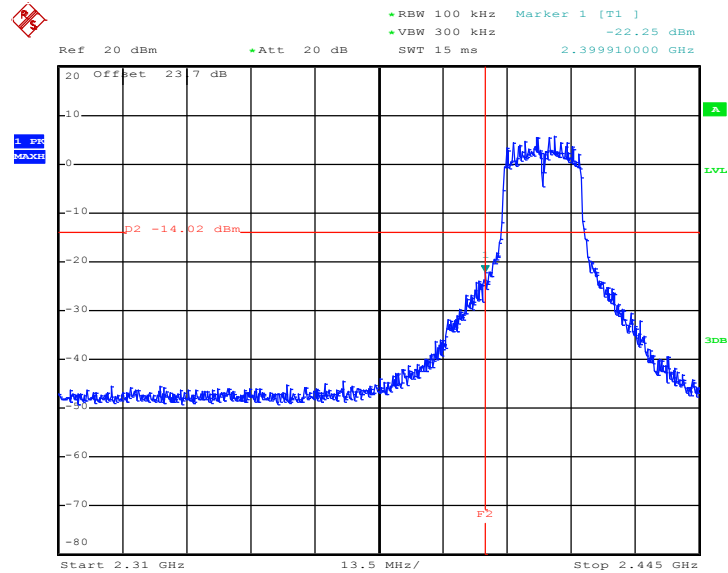

Date: 20.AUG.2012 21:18:25

High Band Edge Plot on 802.11g Channel 11

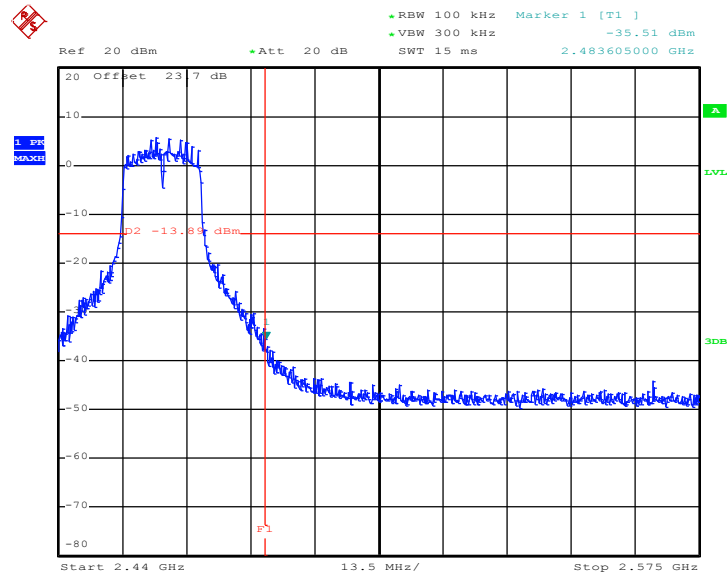

Date: 20.AUG.2012 21:11:03



Test Mode :	802.11n HT20	Temperature :	24~26°C
Test Band :	Low and High	Relative Humidity :	50~53%
Test Channel :	01 and 11	Test Engineer :	Book Lin

Low Band Edge Plot on 802.11n HT20 Channel 01

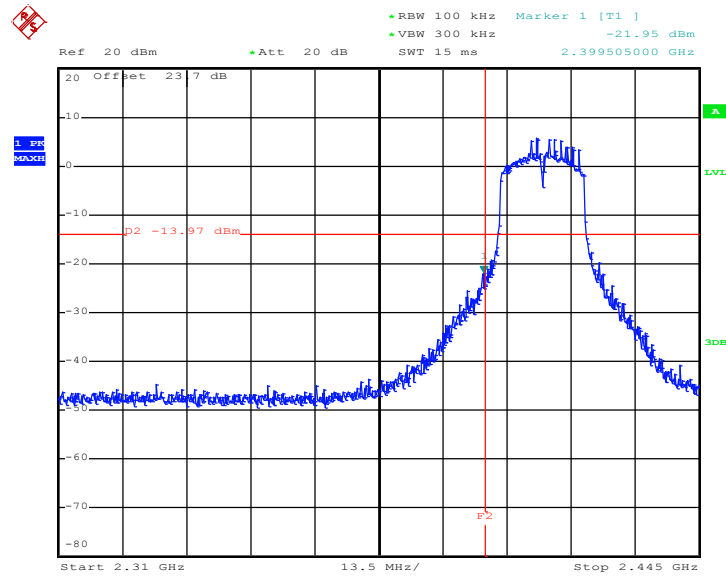

Date: 20.AUG.2012 21:24:14

High Band Edge Plot on 802.11n HT20 Channel 11

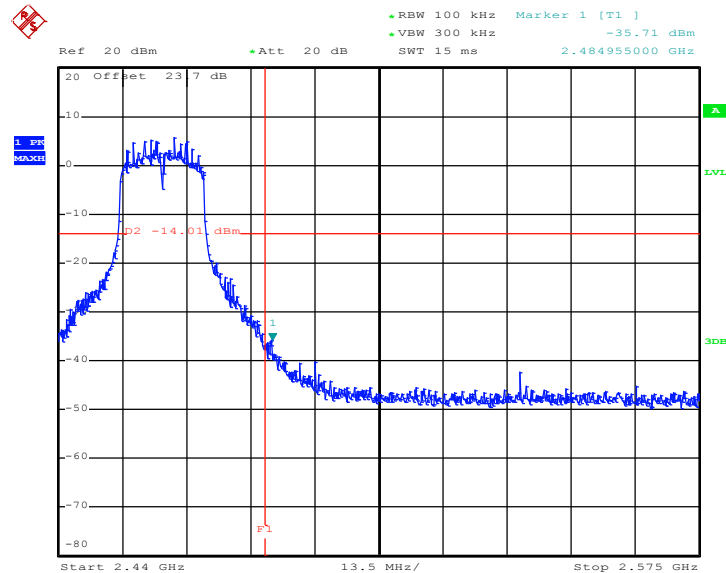

Date: 20.AUG.2012 21:30:55

3.4.6 Test Plots of Spurious Emission

Test Mode :	802.11b	Temperature :	24~26°C
Test Band :	30MHz-3GHz and 2G-25GHz	Relative Humidity :	50~53%
Test Channel :	01, 06, 11	Test Engineer :	Book Lin

802.11b 30 MHz~3 GHz

Conducted Spurious Emission Plot on Channel 01

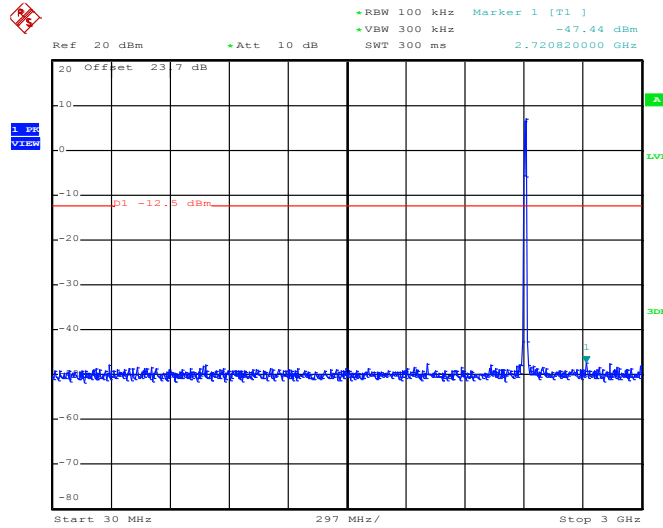

Date: 20.AUG.2012 21:00:21

802.11b 2 GHz~25 GHz

Conducted Spurious Emission Plot on Channel 01

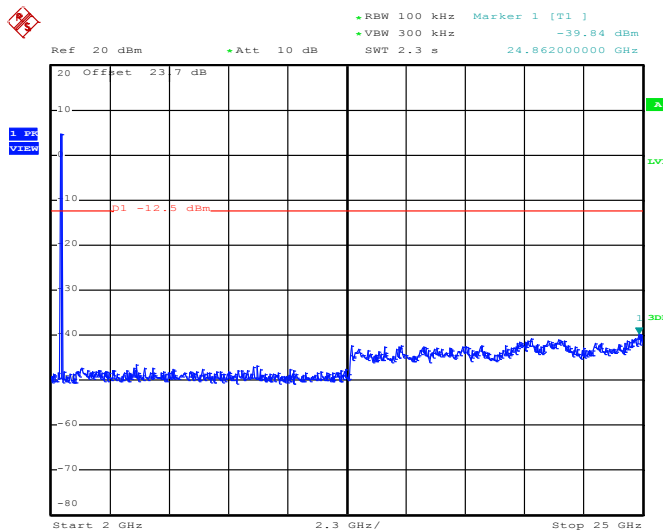

Date: 20.AUG.2012 21:00:39



802.11b 30 MHz~3 GHz

Conducted Spurious Emission Plot on Channel 06

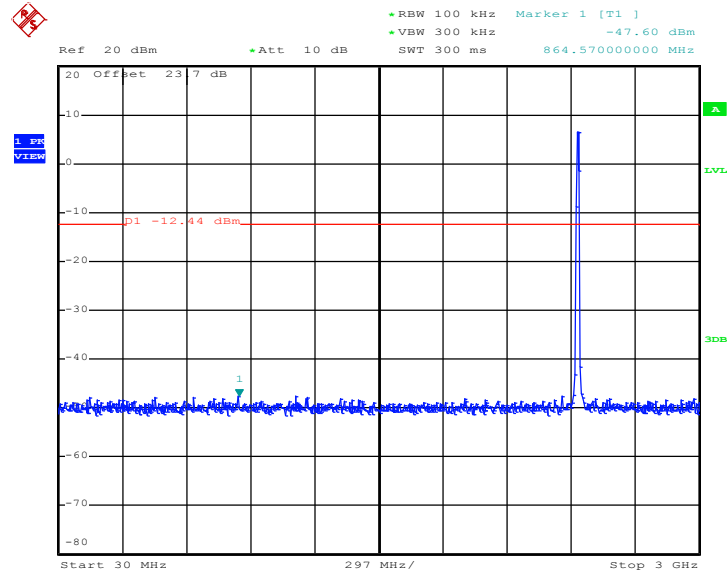

Date: 20.AUG.2012 21:03:23

802.11b 2 GHz~25 GHz

Conducted Spurious Emission Plot on Channel 06

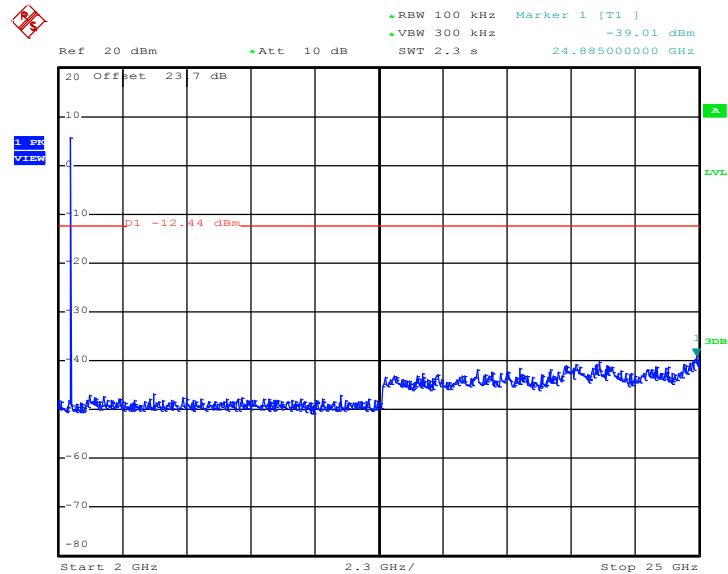

Date: 20.AUG.2012 21:03:41

802.11b 30 MHz~3 GHz

Conducted Spurious Emission Plot on Channel 11

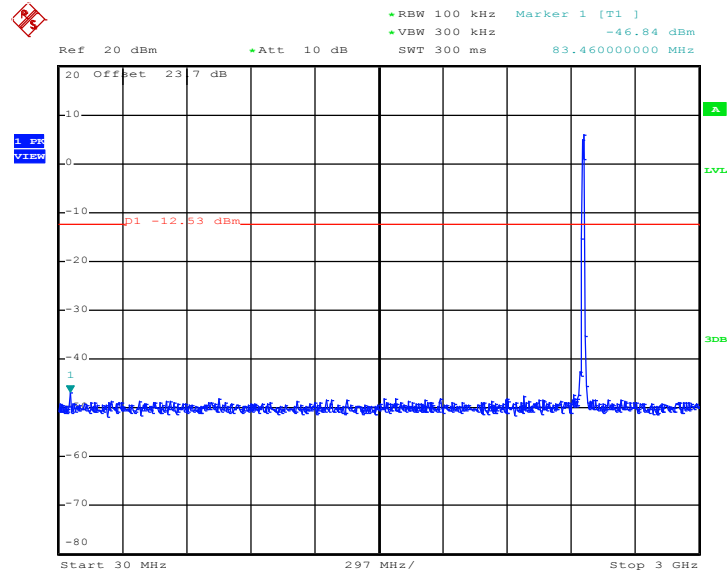

Date: 20.AUG.2012 21:07:25

802.11b 2 GHz~25 GHz

Conducted Spurious Emission Plot on Channel 11

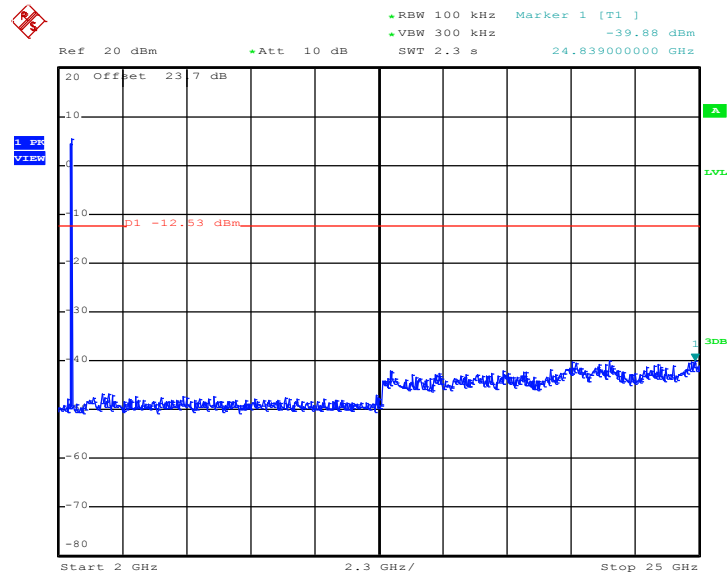

Date: 20.AUG.2012 21:07:43



Test Mode :	802.11g	Temperature :	24~26°C
Test Band :	30MHz-3GHz and 2G-25GHz	Relative Humidity :	50~53%
Test Channel :	01, 06, 11	Test Engineer :	Book Lin

802.11g 30 MHz~3 GHz

Conducted Spurious Emission Plot on Channel 01

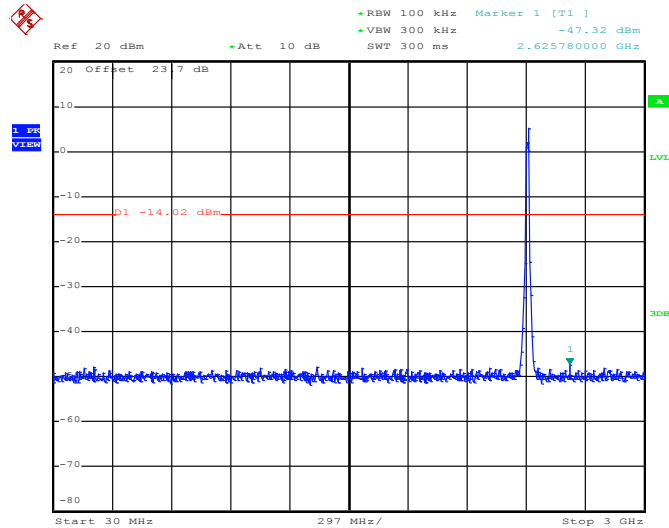

Date: 20.AUG.2012 21:18:55

802.11g 2 GHz~25 GHz

Conducted Spurious Emission Plot on Channel 01

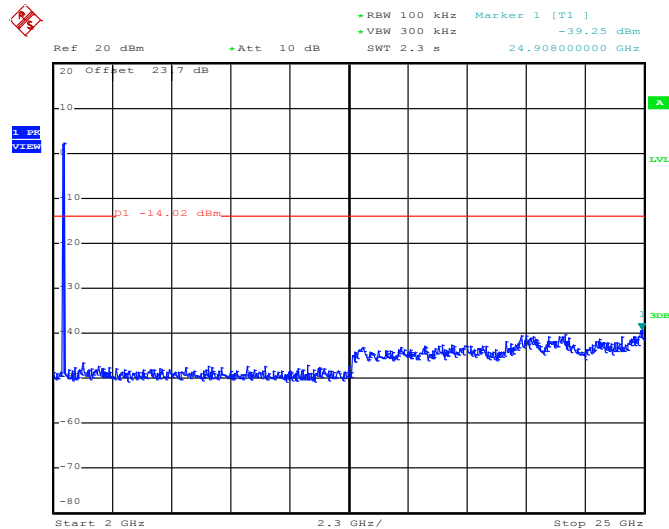

Date: 20.AUG.2012 21:19:19



802.11g 30 MHz~3 GHz

Conducted Spurious Emission Plot on Channel 06

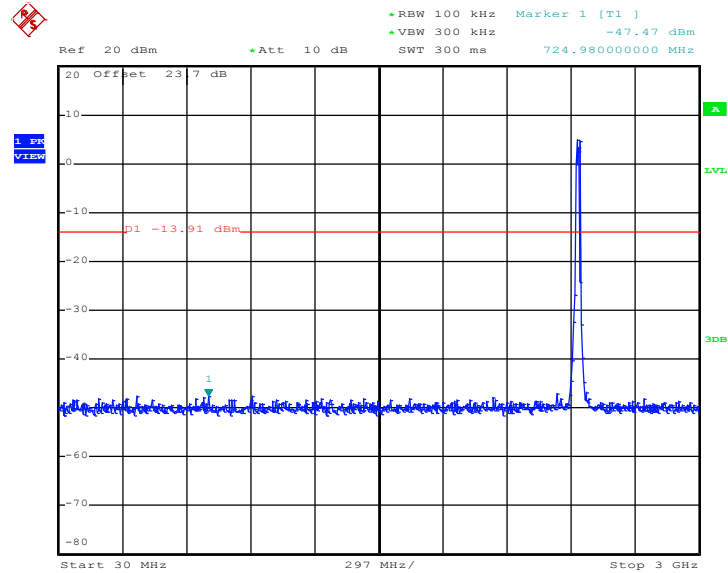

Date: 20.AUG.2012 21:15:21

802.11g 2 GHz~25 GHz

Conducted Spurious Emission Plot on Channel 06

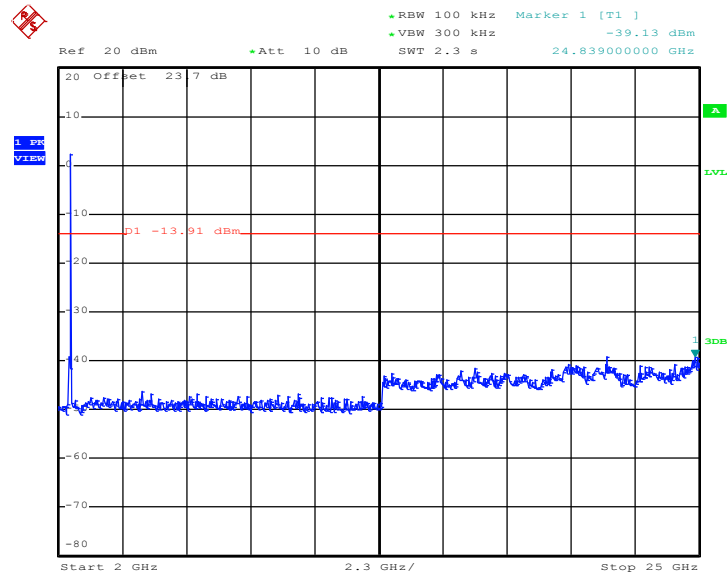

Date: 20.AUG.2012 21:15:39



802.11g 30 MHz~3 GHz

Conducted Spurious Emission Plot on Channel 11

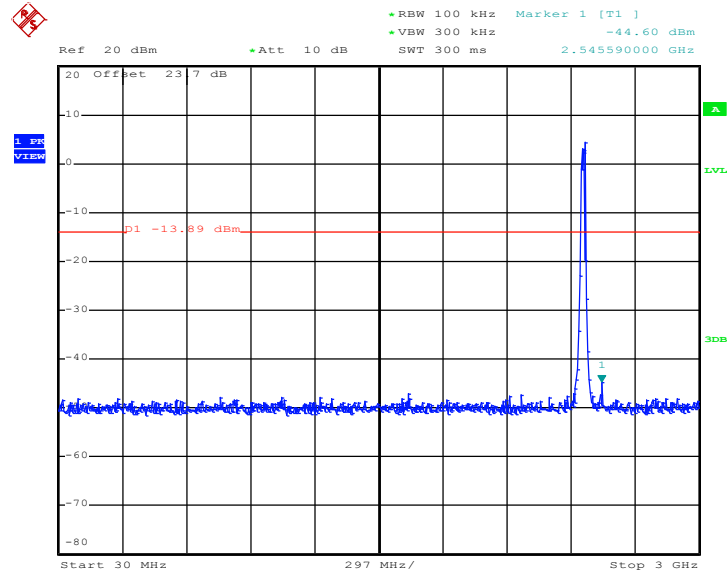

Date: 20.AUG.2012 21:11:34

802.11g 2 GHz~25 GHz

Conducted Spurious Emission Plot on Channel 11

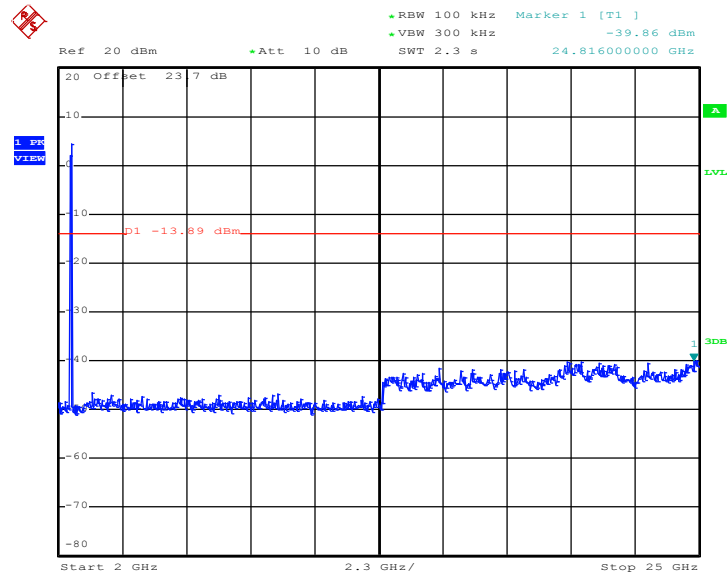

Date: 20.AUG.2012 21:11:52



Test Mode :	802.11n HT20	Temperature :	24~26°C
Test Band :	30MHz-3GHz and 2G-25GHz	Relative Humidity :	50~53%
Test Channel :	01, 06, 11	Test Engineer :	Book Lin

802.11n HT20 30 MHz~3 GHz

Conducted Spurious Emission Plot on Channel 01

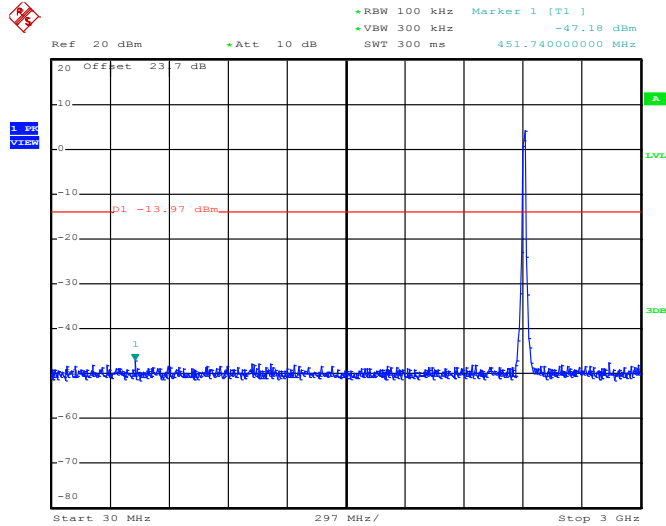

Date: 20.AUG.2012 21:24:45

802.11n HT20 2 GHz~25 GHz

Conducted Spurious Emission Plot on Channel 01

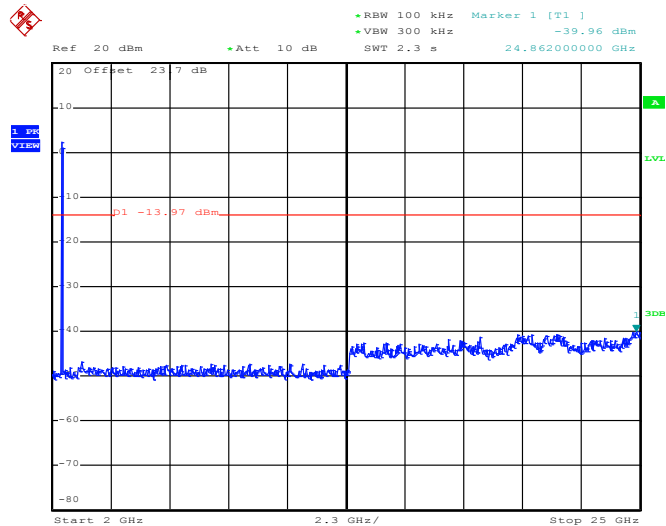

Date: 20.AUG.2012 21:25:03

802.11n HT20 30 MHz~3 GHz

Conducted Spurious Emission Plot on Channel 06

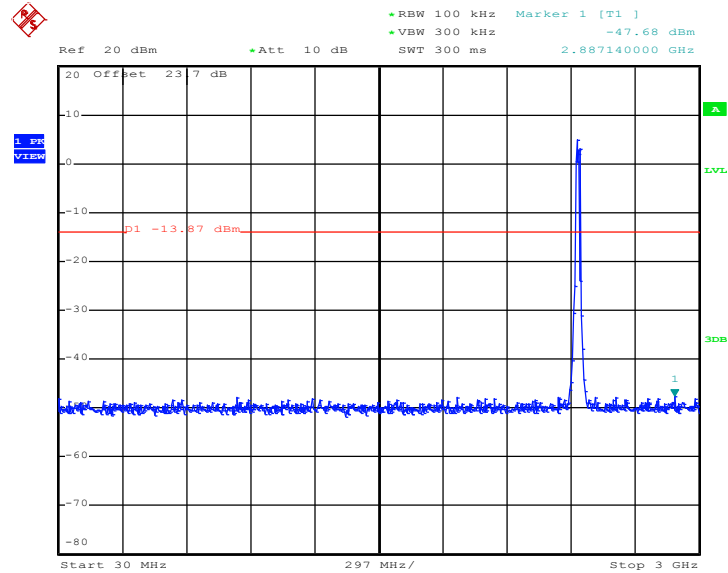

Date: 20.AUG.2012 21:28:01

802.11n HT20 2 GHz~25 GHz

Conducted Spurious Emission Plot on Channel 06

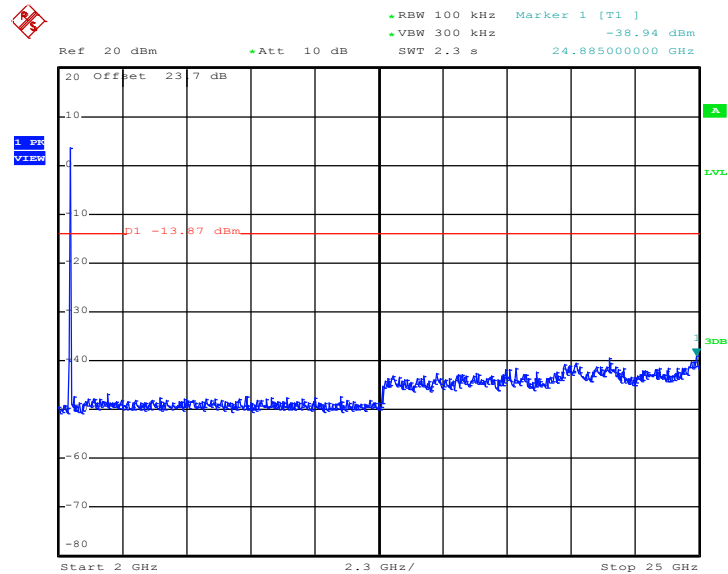

Date: 20.AUG.2012 21:28:19

802.11n HT20 30 MHz~3 GHz

Conducted Spurious Emission Plot on Channel 11

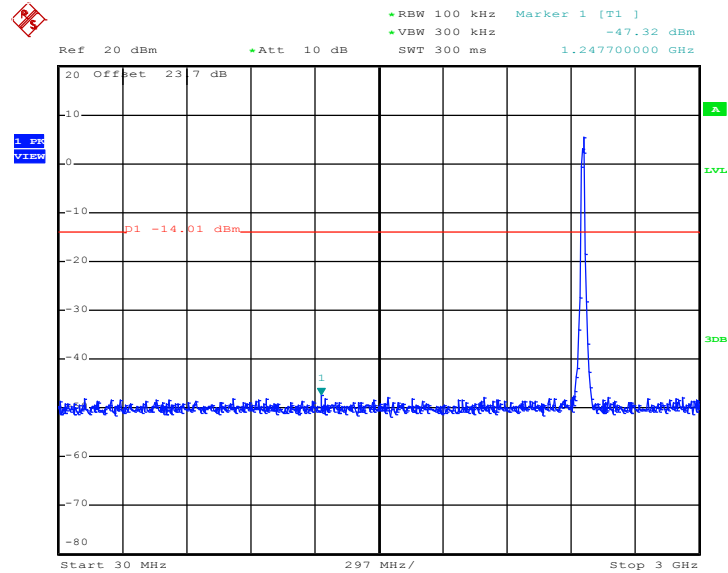

Date: 20.AUG.2012 21:31:23

802.11n HT20 2 GHz~25 GHz

Conducted Spurious Emission Plot on Channel 11

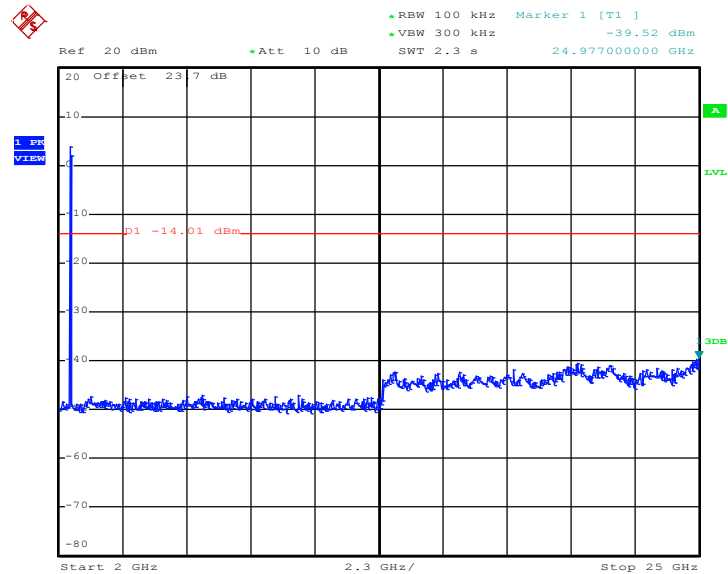

Date: 20.AUG.2012 21:31:41



3.5 Radiated Emission Measurement

3.5.1 Limit of Radiated Emission

In any 100 KHz bandwidth outside the intentional radiator frequency band, all harmonics/spurious must be at least 20 dB below the highest emission level within the authorized band. If the output power of this device was measured by spectrum analyzer, the attenuation under this paragraph shall be 30 dB instead of 20 dB. In addition, radiated emissions which fall in the restricted bands must also comply with the FCC section 15.209 limits as below.

Frequency (MHz)	Field Strength (microvolts/meter)	Measurement Distance (meters)
0.009 – 0.490	2400/F(KHz)	300
0.490 – 1.705	24000/F(KHz)	30
1.705 – 30.0	30	30
30 – 88	100	3
88 – 216	150	3
216 - 960	200	3
Above 960	500	3

3.5.2 Measuring Instruments

See list of measuring instruments of this test report.



3.5.3 Test Procedures

1. The testing follows the guidelines in ANSI C63. 10-2009
2. The EUT was arranged to its worst case and then tune the antenna tower (from 1 m to 4 m) and turntable (from 0 degree to 360 degrees) to find the maximum reading. A pre-amp and a high pass filter are used for the test in order to get better signal level.
3. The EUT was placed on a turntable with 0.8 meter above ground.
4. The EUT was set 3 meters from the interference receiving antenna, which was mounted on the top of a variable height antenna tower.
5. Corrected Reading: Antenna Factor + Cable Loss + Read Level - Preamp Factor = Level
6. For measurement below 1GHz, If the emission level of the EUT measured by the peak detector is 3 dB lower than the applicable limit, the peak emission level will be reported. Otherwise, the emission measurement will be repeated using the quasi-peak detector and reported.
7. Use the following spectrum analyzer settings:
 - (1) Span shall wide enough to fully capture the emission being measured;
 - (2) Set RBW=100 KHz for $f < 1$ GHz; $VBW \geq RBW$; Sweep = auto; Detector function = peak; Trace = max hold;
 - (3) Set RBW = 1 MHz, $VBW = 3$ MHz for $f \geq 1$ GHz for peak measurement.
For average measurement:
 - $VBW = 10$ Hz, when duty cycle is no less than 98 percent.
 - $VBW \geq 1/T$, when duty cycle is less than 98 percent where T is the minimum transmission duration over which the transmitter is on and is transmitting at its maximum power control level for the tested mode of operation.

Band	Duty Cycle (%)	T(us)	1/T(KHz)	VBW Setting
802.11b	100.00	-	-	10Hz
802.11g	97.73	1395.83	0.716	1KHz
2.4G 802.11n HT20	97.76	1310.00	0.763	1KHz

Note: For average measurement with duty cycle < 98%, use reduced VBW measurement method 4.2.3.2.3 in ANSI C63.10.

3.5.4 Test Setup

For radiated emissions below 30MHz

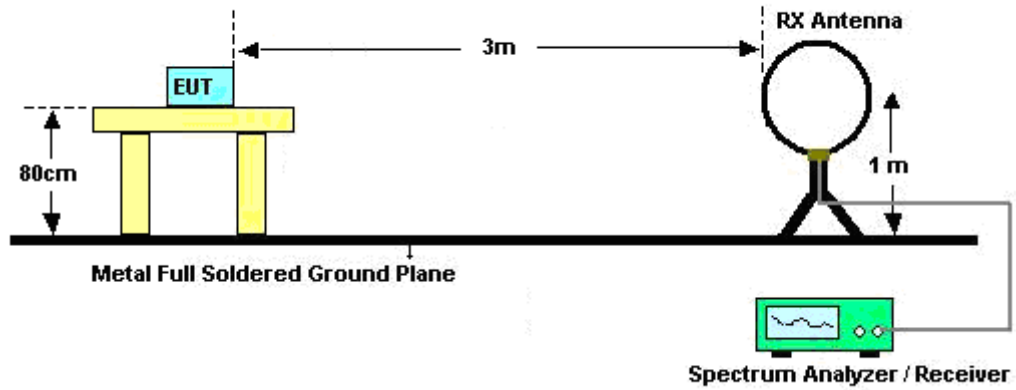

For radiated emissions from 30MHz to 1GHz

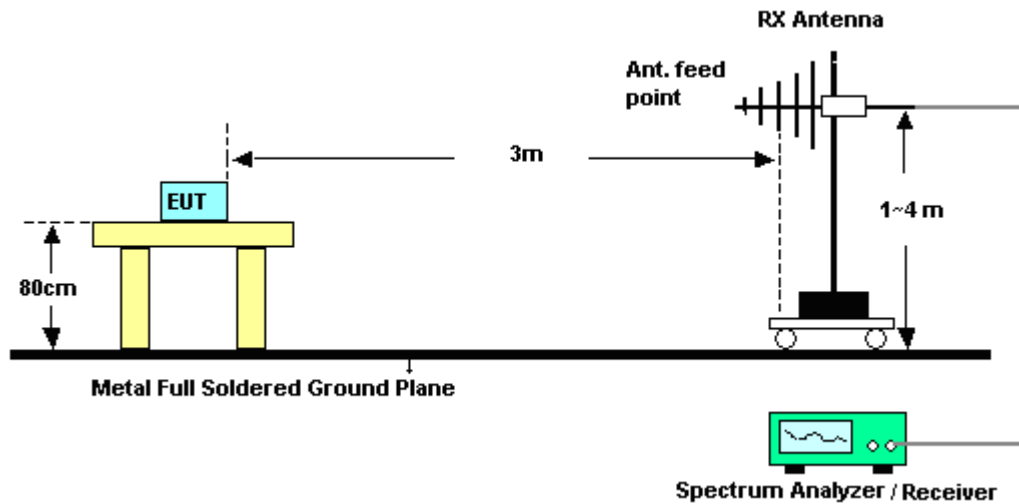

For radiated emissions above 1GHz

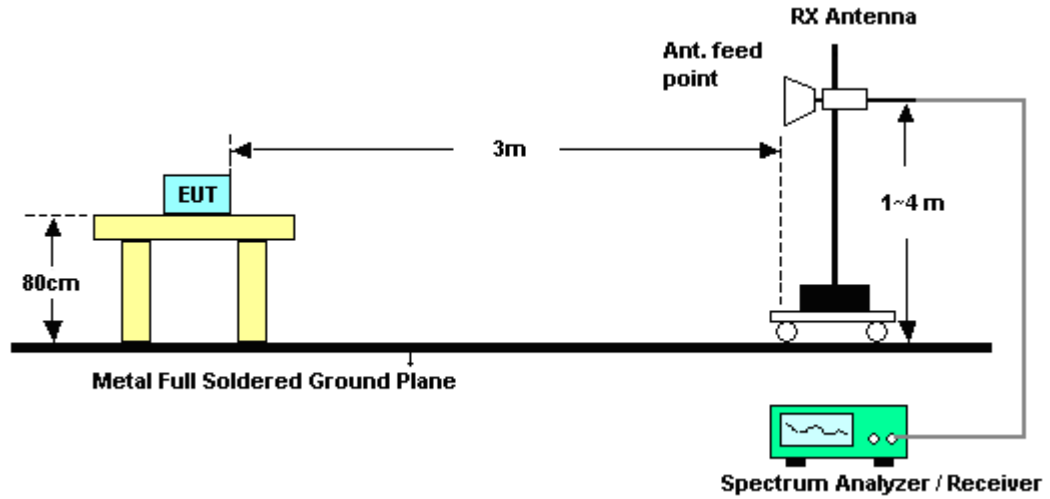

3.5.5 Test Results of Radiated Emissions (9 KHz ~ 30 MHz)

The low frequency, which started from 9 KHz to 30MHz, was pre-scanned and the result which was 20dB lower than the limit line per 15.31(o) was not reported.

3.5.6 Test Result of Radiated Band Edges

<EUT with Adapter 1>

Test Mode :	802.11b	Temperature :	22~23°C
Test Band :	Low	Relative Humidity :	50~52%
Test Channel :	01	Test Engineer :	David Yang

ANTENNA POLARITY : HORIZONTAL										
Frequency (MHz)	Level (dBμV/m)	Over Limit (dB)	Limit Line (dBμV/m)	Read Level (dBμV)	Antenna Factor (dB)	Cable Loss (dB)	Preamp Factor (dB)	Ant Pos (cm)	Table Pos (deg)	Remark
2390	55.45	-18.55	74	54.51	32.22	4.58	35.86	103	308	Peak
2389.92	43.54	-10.46	54	42.6	32.22	4.58	35.86	103	308	Average

ANTENNA POLARITY : VERTICAL										
Frequency (MHz)	Level (dBμV/m)	Over Limit (dB)	Limit Line (dBμV/m)	Read Level (dBμV)	Antenna Factor (dB)	Cable Loss (dB)	Preamp Factor (dB)	Ant Pos (cm)	Table Pos (deg)	Remark
2384.34	50.79	-23.21	74	49.89	32.2	4.58	35.88	160	347	Peak
2390	38.49	-15.51	54	37.55	32.22	4.58	35.86	160	347	Average

Test Mode :	802.11b	Temperature :	22~23°C
Test Band :	High	Relative Humidity :	50~52%
Test Channel :	11	Test Engineer :	David Yang

ANTENNA POLARITY : HORIZONTAL										
Frequency (MHz)	Level (dBμV/m)	Over Limit (dB)	Limit Line (dBμV/m)	Read Level (dBμV)	Antenna Factor (dB)	Cable Loss (dB)	Preamp Factor (dB)	Ant Pos (cm)	Table Pos (deg)	Remark
2483.76	54.37	-19.63	74	53.26	32.28	4.64	35.81	100	307	Peak
2483.5	41.61	-12.39	54	40.5	32.28	4.64	35.81	100	307	Average

ANTENNA POLARITY : VERTICAL										
Frequency (MHz)	Level (dBμV/m)	Over Limit (dB)	Limit Line (dBμV/m)	Read Level (dBμV)	Antenna Factor (dB)	Cable Loss (dB)	Preamp Factor (dB)	Ant Pos (cm)	Table Pos (deg)	Remark
2488.72	50.15	-23.85	74	49.02	32.3	4.64	35.81	152	347	Peak
2486.04	37.22	-16.78	54	36.1	32.29	4.64	35.81	152	347	Average



Test Mode :	802.11g	Temperature :	22~23°C
Test Band :	Low	Relative Humidity :	50~52%
Test Channel :	01	Test Engineer :	David Yang

ANTENNA POLARITY : HORIZONTAL										
Frequency (MHz)	Level (dBμV/m)	Over Limit (dB)	Limit Line (dBμV/m)	Read Level (dBμV)	Antenna Factor (dB)	Cable Loss (dB)	Preamp Factor (dB)	Ant Pos (cm)	Table Pos (deg)	Remark
2386.59	72.22	-1.78	74	71.34	32.18	4.58	35.88	102	313	Peak
2390	50.17	-3.83	54	49.27	32.18	4.58	35.86	102	313	Average

ANTENNA POLARITY : VERTICAL										
Frequency (MHz)	Level (dBμV/m)	Over Limit (dB)	Limit Line (dBμV/m)	Read Level (dBμV)	Antenna Factor (dB)	Cable Loss (dB)	Preamp Factor (dB)	Ant Pos (cm)	Table Pos (deg)	Remark
2388.03	70.71	-3.29	74	69.83	32.18	4.58	35.88	130	327	Peak
2390	46.55	-7.45	54	45.65	32.18	4.58	35.86	130	327	Average

Test Mode :	802.11g	Temperature :	22~23°C
Test Band :	High	Relative Humidity :	50~52%
Test Channel :	11	Test Engineer :	David Yang

ANTENNA POLARITY : HORIZONTAL										
Frequency (MHz)	Level (dBμV/m)	Over Limit (dB)	Limit Line (dBμV/m)	Read Level (dBμV)	Antenna Factor (dB)	Cable Loss (dB)	Preamp Factor (dB)	Ant Pos (cm)	Table Pos (deg)	Remark
2483.7	72.96	-1.04	74	71.85	32.28	4.64	35.81	100	306	Peak
2483.5	49.21	-4.79	54	48.1	32.28	4.64	35.81	100	306	Average

ANTENNA POLARITY : VERTICAL										
Frequency (MHz)	Level (dBμV/m)	Over Limit (dB)	Limit Line (dBμV/m)	Read Level (dBμV)	Antenna Factor (dB)	Cable Loss (dB)	Preamp Factor (dB)	Ant Pos (cm)	Table Pos (deg)	Remark
2483.72	65.98	-8.02	74	64.87	32.28	4.64	35.81	100	316	Peak
2483.52	41.86	-12.14	54	40.75	32.28	4.64	35.81	100	316	Average



Test Mode :	802.11n HT20	Temperature :	22~23°C
Test Band :	Low	Relative Humidity :	50~52%
Test Channel :	01	Test Engineer :	David Yang

ANTENNA POLARITY : HORIZONTAL										
Frequency (MHz)	Level (dBμV/m)	Over Limit (dB)	Limit Line (dBμV/m)	Read Level (dBμV)	Antenna Factor (dB)	Cable Loss (dB)	Preamp Factor (dB)	Ant Pos (cm)	Table Pos (deg)	Remark
2389.74	70.81	-3.19	74	69.93	32.18	4.58	35.88	159	313	Peak
2390	49.95	-4.05	54	49.05	32.18	4.58	35.86	159	313	Average

ANTENNA POLARITY : VERTICAL										
Frequency (MHz)	Level (dBμV/m)	Over Limit (dB)	Limit Line (dBμV/m)	Read Level (dBμV)	Antenna Factor (dB)	Cable Loss (dB)	Preamp Factor (dB)	Ant Pos (cm)	Table Pos (deg)	Remark
2389.92	65.72	-8.28	74	64.82	32.18	4.58	35.86	129	328	Peak
2390	45.57	-8.43	54	44.67	32.18	4.58	35.86	129	328	Average

Test Mode :	802.11n HT20	Temperature :	22~23°C
Test Band :	High	Relative Humidity :	50~52%
Test Channel :	11	Test Engineer :	David Yang

ANTENNA POLARITY : HORIZONTAL										
Frequency (MHz)	Level (dBμV/m)	Over Limit (dB)	Limit Line (dBμV/m)	Read Level (dBμV)	Antenna Factor (dB)	Cable Loss (dB)	Preamp Factor (dB)	Ant Pos (cm)	Table Pos (deg)	Remark
2484.74	61.98	-12.02	74	60.87	32.28	4.64	35.81	100	324	Peak
2483.5	40.58	-13.42	54	39.47	32.28	4.64	35.81	100	324	Average

ANTENNA POLARITY : VERTICAL										
Frequency (MHz)	Level (dBμV/m)	Over Limit (dB)	Limit Line (dBμV/m)	Read Level (dBμV)	Antenna Factor (dB)	Cable Loss (dB)	Preamp Factor (dB)	Ant Pos (cm)	Table Pos (deg)	Remark
2484.74	70.73	-3.27	74	69.62	32.28	4.64	35.81	100	308	Peak
2483.54	49.71	-4.29	54	48.6	32.28	4.64	35.81	100	308	Average



<EUT with Docking 1 and Adapter 2>

Test Mode :	802.11g	Temperature :	22~23°C
Test Band :	High	Relative Humidity :	50~52%
Test Channel :	11	Test Engineer :	David Yang

ANTENNA POLARITY : HORIZONTAL										
Frequency (MHz)	Level (dBμV/m)	Over Limit (dB)	Limit Line (dBμV/m)	Read Level (dBμV)	Antenna Factor (dB)	Cable Loss (dB)	Preamp Factor (dB)	Ant Pos (cm)	Table Pos (deg)	Remark
2483.54	71.43	-2.57	74	70.32	32.28	4.64	35.81	100	308	Peak
2483.62	48.38	-5.62	54	47.27	32.28	4.64	35.81	100	308	Average

ANTENNA POLARITY : VERTICAL										
Frequency (MHz)	Level (dBμV/m)	Over Limit (dB)	Limit Line (dBμV/m)	Read Level (dBμV)	Antenna Factor (dB)	Cable Loss (dB)	Preamp Factor (dB)	Ant Pos (cm)	Table Pos (deg)	Remark
2484.42	64.98	-9.02	74	63.87	32.28	4.64	35.81	155	345	Peak
2483.54	42.84	-11.16	54	41.73	32.28	4.64	35.81	155	345	Average

<EUT with Docking 2 and Car Charger 24V>

Test Mode :	802.11g	Temperature :	22~23°C
Test Band :	High	Relative Humidity :	50~52%
Test Channel :	11	Test Engineer :	David Yang

ANTENNA POLARITY : HORIZONTAL										
Frequency (MHz)	Level (dBμV/m)	Over Limit (dB)	Limit Line (dBμV/m)	Read Level (dBμV)	Antenna Factor (dB)	Cable Loss (dB)	Preamp Factor (dB)	Ant Pos (cm)	Table Pos (deg)	Remark
2483.54	73.14	-0.86	74	72.03	32.28	4.64	35.81	100	57	Peak
2483.54	49.48	-4.52	54	48.37	32.28	4.64	35.81	100	57	Average

ANTENNA POLARITY : VERTICAL										
Frequency (MHz)	Level (dBμV/m)	Over Limit (dB)	Limit Line (dBμV/m)	Read Level (dBμV)	Antenna Factor (dB)	Cable Loss (dB)	Preamp Factor (dB)	Ant Pos (cm)	Table Pos (deg)	Remark
2483.5	68.11	-5.89	74	67	32.28	4.64	35.81	183	208	Peak
2483.5	44.97	-9.03	54	43.86	32.28	4.64	35.81	183	208	Average

3.5.7 Test Result of Radiated Emission (30 MHz ~ 10th Harmonic)

<EUT with Adapter 1>

Test Mode :	802.11b	Temperature :	22~23°C
Test Channel :	01	Relative Humidity :	50~52%
Test Engineer :	David Yang	Polarization :	Horizontal
Remark :	2412 MHz is fundamental signal which can be ignored.		

Frequency (MHz)	Level (dBμV/m)	Over Limit (dB)	Limit Line (dBμV/m)	Read Level (dBμV)	Antenna Factor (dB)	Cable Loss (dB)	Preamp Factor (dB)	Ant Pos (cm)	Table Pos (deg)	Remark
2412	104.74	-	-	103.78	32.23	4.59	35.86	103	308	Average
2412	109.68	-	-	108.72	32.23	4.59	35.86	103	308	Peak

Test Mode :	802.11b	Temperature :	22~23°C
Test Channel :	01	Relative Humidity :	50~52%
Test Engineer :	David Yang	Polarization :	Vertical
Remark :	2412 MHz is fundamental signal which can be ignored.		

Frequency (MHz)	Level (dBμV/m)	Over Limit (dB)	Limit Line (dBμV/m)	Read Level (dBμV)	Antenna Factor (dB)	Cable Loss (dB)	Preamp Factor (dB)	Ant Pos (cm)	Table Pos (deg)	Remark
2412	99.4	-	-	98.44	32.23	4.59	35.86	160	347	Average
2412	103.96	-	-	103	32.23	4.59	35.86	160	347	Peak



Test Mode :	802.11b	Temperature :	22~23°C
Test Channel :	06	Relative Humidity :	50~52%
Test Engineer :	David Yang	Polarization :	Horizontal
Remark :	2437 MHz is fundamental signal which can be ignored.		

Frequency (MHz)	Level (dBμV/m)	Over Limit (dB)	Limit Line (dBμV/m)	Read Level (dBμV)	Antenna Factor (dB)	Cable Loss (dB)	Preamp Factor (dB)	Ant Pos (cm)	Table Pos (deg)	Remark
2437	105.74	-	-	104.71	32.26	4.61	35.84	102	308	Average
2437	110.31	-	-	109.28	32.26	4.61	35.84	102	308	Peak

Test Mode :	802.11b	Temperature :	22~23°C
Test Channel :	06	Relative Humidity :	50~52%
Test Engineer :	David Yang	Polarization :	Vertical
Remark :	2437 MHz is fundamental signal which can be ignored.		

Frequency (MHz)	Level (dBμV/m)	Over Limit (dB)	Limit Line (dBμV/m)	Read Level (dBμV)	Antenna Factor (dB)	Cable Loss (dB)	Preamp Factor (dB)	Ant Pos (cm)	Table Pos (deg)	Remark
2437	99.54	-	-	98.51	32.26	4.61	35.84	129	329	Average
2437	104.36	-	-	103.33	32.26	4.61	35.84	129	329	Peak



Test Mode :	802.11b	Temperature :	22~23°C
Test Channel :	11	Relative Humidity :	50~52%
Test Engineer :	David Yang	Polarization :	Horizontal
Remark :	2462 MHz is fundamental signal which can be ignored.		

Frequency (MHz)	Level (dBμV/m)	Over Limit (dB)	Limit Line (dBμV/m)	Read Level (dBμV)	Antenna Factor (dB)	Cable Loss (dB)	Preamp Factor (dB)	Ant Pos (cm)	Table Pos (deg)	Remark
2462	105.72	-	-	104.67	32.26	4.62	35.83	100	307	Average
2462	110.62	-	-	109.57	32.26	4.62	35.83	100	307	Peak

Test Mode :	802.11b	Temperature :	22~23°C
Test Channel :	11	Relative Humidity :	50~52%
Test Engineer :	David Yang	Polarization :	Vertical
Remark :	2462 MHz is fundamental signal which can be ignored.		

Frequency (MHz)	Level (dBμV/m)	Over Limit (dB)	Limit Line (dBμV/m)	Read Level (dBμV)	Antenna Factor (dB)	Cable Loss (dB)	Preamp Factor (dB)	Ant Pos (cm)	Table Pos (deg)	Remark
2462	98.87	-	-	97.81	32.27	4.62	35.83	152	347	Average
2462	103.72	-	-	102.66	32.27	4.62	35.83	152	347	Peak



Test Mode :	802.11g	Temperature :	22~23°C
Test Channel :	01	Relative Humidity :	50~52%
Test Engineer :	David Yang	Polarization :	Horizontal
Remark :	2412 MHz is fundamental signal which can be ignored.		

Frequency (MHz)	Level (dBμV/m)	Over Limit (dB)	Limit Line (dBμV/m)	Read Level (dBμV)	Antenna Factor (dB)	Cable Loss (dB)	Preamp Factor (dB)	Ant Pos (cm)	Table Pos (deg)	Remark
2412	101.43	-	-	100.5	32.2	4.59	35.86	102	313	Average
2412	112.11	-	-	111.18	32.2	4.59	35.86	102	313	Peak

Test Mode :	802.11g	Temperature :	22~23°C
Test Channel :	01	Relative Humidity :	50~52%
Test Engineer :	David Yang	Polarization :	Vertical
Remark :	2412 MHz is fundamental signal which can be ignored.		

Frequency (MHz)	Level (dBμV/m)	Over Limit (dB)	Limit Line (dBμV/m)	Read Level (dBμV)	Antenna Factor (dB)	Cable Loss (dB)	Preamp Factor (dB)	Ant Pos (cm)	Table Pos (deg)	Remark
2412	97.09	-	-	96.16	32.2	4.59	35.86	130	327	Average
2412	107.44	-	-	106.51	32.2	4.59	35.86	130	327	Peak



Test Mode :	802.11g	Temperature :	22~23°C
Test Channel :	06	Relative Humidity :	50~52%
Test Engineer :	David Yang	Polarization :	Horizontal
Remark :	2437 MHz is fundamental signal which can be ignored.		

Frequency (MHz)	Level (dBμV/m)	Over Limit (dB)	Limit Line (dBμV/m)	Read Level (dBμV)	Antenna Factor (dB)	Cable Loss (dB)	Preamp Factor (dB)	Ant Pos (cm)	Table Pos (deg)	Remark
2437	103.37	-	-	102.38	32.22	4.61	35.84	100	305	Average
2437	113.75	-	-	112.76	32.22	4.61	35.84	100	305	Peak

Test Mode :	802.11g	Temperature :	22~23°C
Test Channel :	06	Relative Humidity :	50~52%
Test Engineer :	David Yang	Polarization :	Vertical
Remark :	2437 MHz is fundamental signal which can be ignored.		

Frequency (MHz)	Level (dBμV/m)	Over Limit (dB)	Limit Line (dBμV/m)	Read Level (dBμV)	Antenna Factor (dB)	Cable Loss (dB)	Preamp Factor (dB)	Ant Pos (cm)	Table Pos (deg)	Remark
2437	97.23	-	-	96.24	32.22	4.61	35.84	158	301	Average
2437	107.64	-	-	106.65	32.22	4.61	35.84	158	301	Peak



Test Mode :	802.11g	Temperature :	22~23°C
Test Channel :	11	Relative Humidity :	50~52%
Test Engineer :	David Yang	Polarization :	Horizontal
Remark :	2462 MHz is fundamental signal which can be ignored.		

Frequency (MHz)	Level (dBμV/m)	Over Limit (dB)	Limit Line (dBμV/m)	Read Level (dBμV)	Antenna Factor (dB)	Cable Loss (dB)	Preamp Factor (dB)	Ant Pos (cm)	Table Pos (deg)	Remark
32.97	26.13	-13.87	40	39.28	17.76	0.72	31.63	100	167	Peak
113.7	26.39	-17.11	43.5	45.09	11.6	1.17	31.47	-	-	Peak
198.75	28.77	-14.73	43.5	49.39	9.04	1.46	31.12	-	-	Peak
398	29.73	-16.27	46	43.01	15.9	2.01	31.19	-	-	Peak
454.7	30.02	-15.98	46	41.56	17.3	2.15	30.99	-	-	Peak
796.3	28.95	-17.05	46	33.95	22.02	2.82	29.84	-	-	Peak
2462	101.35	-	-	100.3	32.26	4.62	35.83	100	306	Average
2462	111.52	-	-	110.47	32.26	4.62	35.83	100	306	Peak



Test Mode :	802.11g	Temperature :	22~23°C
Test Channel :	11	Relative Humidity :	50~52%
Test Engineer :	David Yang	Polarization :	Vertical
Remark :	2462 MHz is fundamental signal which can be ignored.		

Frequency (MHz)	Level (dBμV/m)	Over Limit (dB)	Limit Line (dBμV/m)	Read Level (dBμV)	Antenna Factor (dB)	Cable Loss (dB)	Preamp Factor (dB)	Ant Pos (cm)	Table Pos (deg)	Remark
42.42	33.09	-6.91	40	52.33	11.56	0.76	31.56	100	33	Peak
84	26.36	-13.64	40	48.68	8.02	1.03	31.37	-	-	Peak
196.05	30.94	-12.56	43.5	51.75	8.86	1.45	31.12	-	-	Peak
398	30.32	-15.68	46	43.6	15.9	2.01	31.19	-	-	Peak
568.8	32.01	-13.99	46	40.49	19.97	2.36	30.81	-	-	Peak
796.3	29.66	-16.34	46	34.66	22.02	2.82	29.84	-	-	Peak
2462	93.46	-	-	92.41	32.26	4.62	35.83	100	316	Average
2462	104.75	-	-	103.7	32.26	4.62	35.83	100	316	Peak



Test Mode :	802.11n-HT20	Temperature :	22~23°C
Test Channel :	01	Relative Humidity :	50~52%
Test Engineer :	David Yang	Polarization :	Horizontal
Remark :	2412 MHz is fundamental signal which can be ignored.		

Frequency (MHz)	Level (dBμV/m)	Over Limit (dB)	Limit Line (dBμV/m)	Read Level (dBμV)	Antenna Factor (dB)	Cable Loss (dB)	Preamp Factor (dB)	Ant Pos (cm)	Table Pos (deg)	Remark
42.42	22.02	-17.98	40	41.26	11.56	0.76	31.56	-	-	Peak
170.67	26.41	-17.09	43.5	46.73	9.42	1.36	31.1	-	-	Peak
222.51	27.73	-18.27	46	47.64	9.48	1.55	30.94	-	-	Peak
341.3	29.34	-16.66	46	44.46	14.14	1.88	31.14	-	-	Peak
454.7	30.57	-15.43	46	42.11	17.3	2.15	30.99	100	74	Peak
626.2	25.23	-20.77	46	32.41	20.56	2.51	30.25	-	-	Peak
2412	99.91	-	-	98.96	32.2	4.59	35.84	159	313	Average
2412	110.27	-	-	109.32	32.2	4.59	35.84	159	313	Peak



Test Mode :	802.11n-HT20	Temperature :	22~23°C
Test Channel :	01	Relative Humidity :	50~52%
Test Engineer :	David Yang	Polarization :	Vertical
Remark :	2410 MHz is fundamental signal which can be ignored.		

Frequency (MHz)	Level (dBμV/m)	Over Limit (dB)	Limit Line (dBμV/m)	Read Level (dBμV)	Antenna Factor (dB)	Cable Loss (dB)	Preamp Factor (dB)	Ant Pos (cm)	Table Pos (deg)	Remark
49.98	29.09	-10.91	40	51.79	7.9	0.81	31.41	100	41	Peak
83.46	26.64	-13.36	40	49.05	7.94	1.02	31.37	-	-	Peak
193.62	29.67	-13.83	43.5	50.55	8.78	1.45	31.11	-	-	Peak
398	30.4	-15.6	46	43.68	15.9	2.01	31.19	-	-	Peak
682.9	26.84	-19.16	46	33.93	20.46	2.63	30.18	-	-	Peak
796.3	29.75	-16.25	46	34.75	22.02	2.82	29.84	-	-	Peak
2410	94.67	-	-	93.74	32.2	4.59	35.86	129	328	Average
2410	105.05	-	-	104.12	32.2	4.59	35.86	129	328	Peak



Test Mode :	802.11n-HT20	Temperature :	22~23°C
Test Channel :	06	Relative Humidity :	50~52%
Test Engineer :	David Yang	Polarization :	Horizontal
Remark :	2437 MHz is fundamental signal which can be ignored.		

Frequency (MHz)	Level (dBμV/m)	Over Limit (dB)	Limit Line (dBμV/m)	Read Level (dBμV)	Antenna Factor (dB)	Cable Loss (dB)	Preamp Factor (dB)	Ant Pos (cm)	Table Pos (deg)	Remark
2437	103.01	-	-	102	32.24	4.61	35.84	100	304	Average
2437	113.31	-	-	112.3	32.24	4.61	35.84	100	304	Peak

Test Mode :	802.11n-HT20	Temperature :	22~23°C
Test Channel :	06	Relative Humidity :	50~52%
Test Engineer :	David Yang	Polarization :	Vertical
Remark :	2437 MHz is fundamental signal which can be ignored.		

Frequency (MHz)	Level (dBμV/m)	Over Limit (dB)	Limit Line (dBμV/m)	Read Level (dBμV)	Antenna Factor (dB)	Cable Loss (dB)	Preamp Factor (dB)	Ant Pos (cm)	Table Pos (deg)	Remark
2437	96.78	-	-	95.79	32.22	4.61	35.84	161	313	Average
2437	107.02	-	-	106.03	32.22	4.61	35.84	161	313	Peak



Test Mode :	802.11n-HT20	Temperature :	22~23°C
Test Channel :	11	Relative Humidity :	50~52%
Test Engineer :	David Yang	Polarization :	Horizontal
Remark :	2462 MHz is fundamental signal which can be ignored.		

Frequency (MHz)	Level (dBμV/m)	Over Limit (dB)	Limit Line (dBμV/m)	Read Level (dBμV)	Antenna Factor (dB)	Cable Loss (dB)	Preamp Factor (dB)	Ant Pos (cm)	Table Pos (deg)	Remark
2462	99.89	-	-	98.84	32.26	4.62	35.83	100	308	Average
2462	110.21	-	-	109.16	32.26	4.62	35.83	100	308	Peak

Test Mode :	802.11n-HT20	Temperature :	22~23°C
Test Channel :	11	Relative Humidity :	50~52%
Test Engineer :	David Yang	Polarization :	Vertical
Remark :	2462 MHz is fundamental signal which can be ignored.		

Frequency (MHz)	Level (dBμV/m)	Over Limit (dB)	Limit Line (dBμV/m)	Read Level (dBμV)	Antenna Factor (dB)	Cable Loss (dB)	Preamp Factor (dB)	Ant Pos (cm)	Table Pos (deg)	Remark
2462	91.68	-	-	90.63	32.26	4.62	35.83	100	324	Average
2462	101.95	-	-	100.9	32.26	4.62	35.83	100	324	Peak



<EUT with Docking 1 and Adapter 2>

Test Mode :	802.11g	Temperature :	22~23°C
Test Channel :	11	Relative Humidity :	50~52%
Test Engineer :	David Yang	Polarization :	Horizontal
Remark :	2462 MHz is fundamental signal which can be ignored.		

Frequency (MHz)	Level (dBμV/m)	Over Limit (dB)	Limit Line (dBμV/m)	Read Level (dBμV)	Antenna Factor (dB)	Cable Loss (dB)	Preamp Factor (dB)	Ant Pos (cm)	Table Pos (deg)	Remark
32.97	30.12	-9.88	40	43.27	17.76	0.72	31.63	-	-	Peak
191.73	29.68	-13.82	43.5	50.61	8.74	1.44	31.11	-	-	Peak
234.66	36.34	-9.66	46	54.87	10.8	1.6	30.93	-	-	Peak
341.3	36.38	-9.62	46	51.5	14.14	1.88	31.14	135	261	Peak
398	33.49	-12.51	46	46.77	15.9	2.01	31.19	-	-	Peak
568.8	32.09	-13.91	46	40.57	19.97	2.36	30.81	-	-	Peak
2462	99.48	-	-	98.43	32.26	4.62	35.83	100	308	Average
2462	109.68	-	-	108.63	32.26	4.62	35.83	100	308	Peak



Test Mode :	802.11g	Temperature :	22~23°C
Test Channel :	11	Relative Humidity :	50~52%
Test Engineer :	David Yang	Polarization :	Vertical
Remark :	2462 MHz is fundamental signal which can be ignored.		

Frequency (MHz)	Level (dBμV/m)	Over Limit (dB)	Limit Line (dBμV/m)	Read Level (dBμV)	Antenna Factor (dB)	Cable Loss (dB)	Preamp Factor (dB)	Ant Pos (cm)	Table Pos (deg)	Remark
32.97	34	-6	40	47.15	17.76	0.72	31.63	100	199	Peak
199.29	28.25	-15.25	43.5	48.81	9.1	1.46	31.12	-	-	Peak
231.69	31.54	-14.46	46	50.44	10.44	1.59	30.93	-	-	Peak
341.3	32.76	-13.24	46	47.88	14.14	1.88	31.14	-	-	Peak
398	33.2	-12.8	46	46.48	15.9	2.01	31.19	-	-	Peak
568.8	34.02	-11.98	46	42.5	19.97	2.36	30.81	-	-	Peak
2462	95.98	-	-	94.93	32.26	4.62	35.83	155	345	Average
2462	106.34	-	-	105.29	32.26	4.62	35.83	155	345	Peak



<EUT with Docking 2 and Car Charger 24V>

Test Mode :	802.11g	Temperature :	22~23°C
Test Channel :	11	Relative Humidity :	50~52%
Test Engineer :	David Yang	Polarization :	Horizontal
Remark :	2462 MHz is fundamental signal which can be ignored.		

Frequency (MHz)	Level (dBμV/m)	Over Limit (dB)	Limit Line (dBμV/m)	Read Level (dBμV)	Antenna Factor (dB)	Cable Loss (dB)	Preamp Factor (dB)	Ant Pos (cm)	Table Pos (deg)	Remark
31.08	28.06	-11.94	40	39.87	19.12	0.71	31.64	155	104	Peak
165.81	30.32	-13.18	43.5	50.13	9.98	1.36	31.15	-	-	Peak
193.08	25.73	-17.77	43.5	46.63	8.76	1.45	31.11	-	-	Peak
341.3	31.62	-14.38	46	46.74	14.14	1.88	31.14	-	-	Peak
398	33.07	-12.93	46	46.35	15.9	2.01	31.19	-	-	Peak
568.8	31.63	-14.37	46	40.11	19.97	2.36	30.81	-	-	Peak
2462	100.77	-	-	99.72	32.26	4.62	35.83	100	57	Average
2462	111.09	-	-	110.04	32.26	4.62	35.83	100	57	Peak



Test Mode :	802.11g	Temperature :	22~23°C
Test Channel :	11	Relative Humidity :	50~52%
Test Engineer :	David Yang	Polarization :	Vertical
Remark :	2462 MHz is fundamental signal which can be ignored.		

Frequency (MHz)	Level (dBμV/m)	Over Limit (dB)	Limit Line (dBμV/m)	Read Level (dBμV)	Antenna Factor (dB)	Cable Loss (dB)	Preamp Factor (dB)	Ant Pos (cm)	Table Pos (deg)	Remark
32.97	32.96	-7.04	40	46.11	17.76	0.72	31.63	100	336	Peak
66.45	24.22	-15.78	40	48.8	6.06	0.89	31.53	-	-	Peak
164.46	28.93	-14.57	43.5	48.64	10.1	1.36	31.17	-	-	Peak
341.3	34.39	-11.61	46	49.51	14.14	1.88	31.14	-	-	Peak
398	33.17	-12.83	46	46.45	15.9	2.01	31.19	-	-	Peak
960.8	36.38	-17.62	54	38.41	24.92	3.1	30.05	-	-	Peak
2462	96.63	-	-	95.58	32.26	4.62	35.83	183	208	Average
2462	106.83	-	-	105.78	32.26	4.62	35.83	183	208	Peak

3.6 AC Conducted Emission Measurement

3.6.1 Limit of AC Conducted Emission

For equipment that is designed to be connected to the public utility (AC) power line, the radio frequency voltage that is conducted back onto the AC power line on any frequency or frequencies within the band 150 KHz to 30 MHz shall not exceed the limits in the following table.

Frequency of Emission (MHz)	Conducted Limit (dBuV)	
	Quasi-Peak	Average
0.15-0.5	66 to 56*	56 to 46*
0.5-5	56	46
5-30	60	50

*Decreases with the logarithm of the frequency.

3.6.2 Measuring Instruments

See list of measuring instruments of this test report.

3.6.3 Test Procedures

1. The testing follows the guidelines in ANSI C63.4-2003 and ANSI C63.10-2009.
2. The EUT was placed 0.4 meter from the conducting wall of the shielding room, and it was kept at least 80 centimeters from any other grounded conducting surface.
3. Connect EUT to the power mains through a line impedance stabilization network (LISN).
4. All the support units are connecting to the other LISN.
5. The LISN provides 50 ohm coupling impedance for the measuring instrument.
6. The FCC states that a 50 ohm, 50 microhenry LISN should be used.
7. Both sides of AC line were checked for maximum conducted interference.
8. The frequency range from 150 KHz to 30 MHz was searched.
9. Set the test-receiver system to Peak Detect Function and specified bandwidth with Maximum Hold Mode.

3.6.4 Test Setup

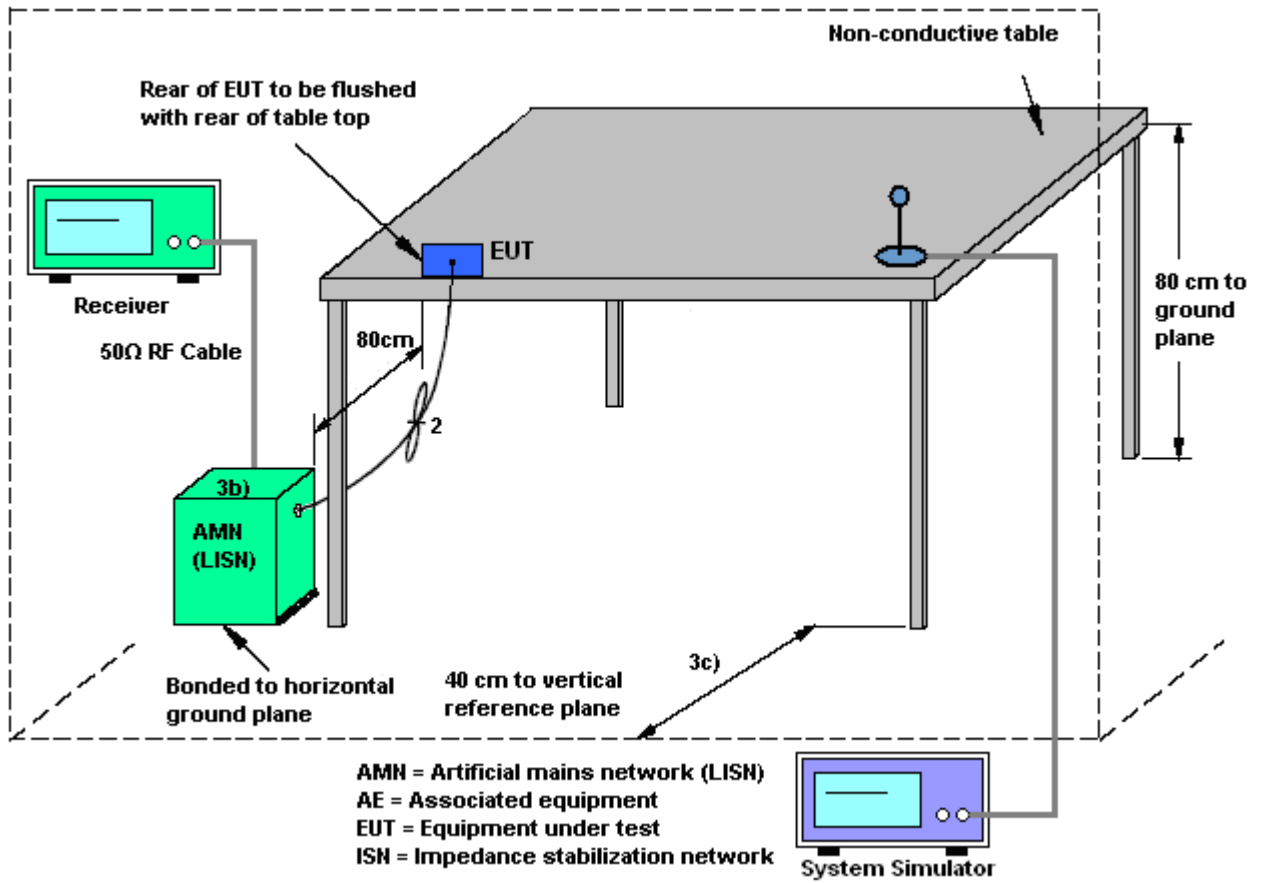

3.6.5 Test Result of AC Conducted Emission

Test Mode :	Mode 3	Temperature :	20~22°C
Test Engineer :	Kai-Chun Chu	Relative Humidity :	49~51%
Test Voltage :	120Vac / 60Hz	Phase :	Line
Function Type :	GSM1900 (GPRS 8) Idle + WLAN Link + Bluetooth Link + RFID On + MPEG4 + TC3		
Remark :	All emissions not reported here are more than 10 dB below the prescribed limit. 13.558 MHz is fundamental signal of RFID/NFC which can be ignored.		

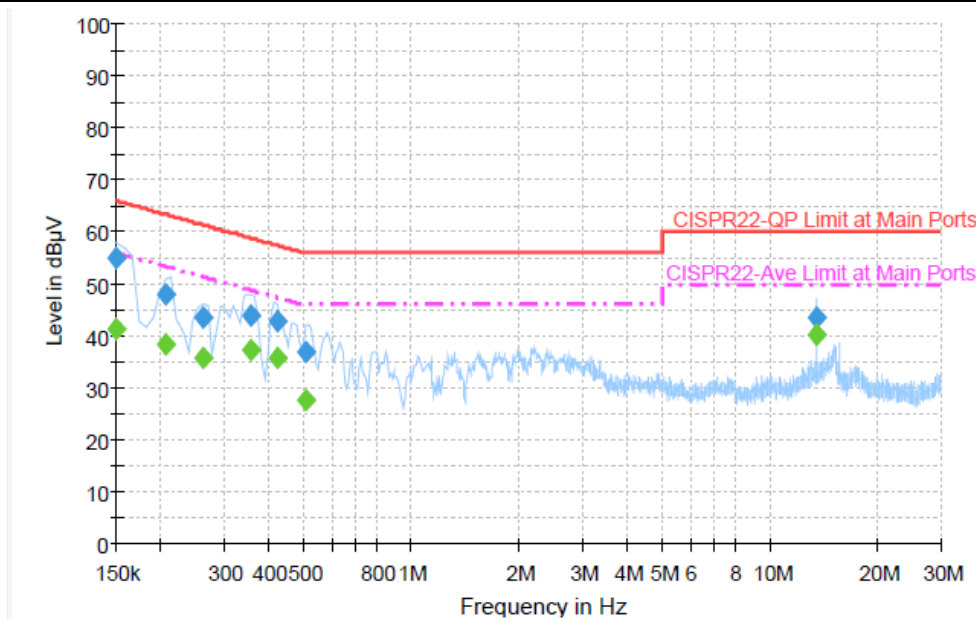

Final Result : Quasi-Peak

Frequency (MHz)	Quasi-Peak (dBμV)	Filter	Line	Corr. (dB)	Margin (dB)	Limit (dBμV)
0.150000	54.8	Off	L1	19.4	11.2	66.0
0.206000	48.1	Off	L1	19.4	15.3	63.4
0.262000	43.4	Off	L1	19.4	18.0	61.4
0.358000	43.8	Off	L1	19.4	15.0	58.8
0.422000	43.0	Off	L1	19.4	14.4	57.4
0.510000	37.0	Off	L1	19.4	19.0	56.0
13.558000	43.4	Off	L1	19.8	16.6	60.0

Final Result : Average

Frequency (MHz)	Average (dBμV)	Filter	Line	Corr. (dB)	Margin (dB)	Limit (dBμV)
0.150000	41.2	Off	L1	19.4	14.8	56.0
0.206000	38.4	Off	L1	19.4	15.0	53.4
0.262000	35.6	Off	L1	19.4	15.8	51.4
0.358000	37.3	Off	L1	19.4	11.5	48.8
0.422000	35.7	Off	L1	19.4	11.7	47.4
0.510000	27.6	Off	L1	19.4	18.4	46.0
13.558000	40.2	Off	L1	19.8	9.8	50.0

Test Mode :	Mode 3	Temperature :	20~22°C
Test Engineer :	Kai-Chun Chu	Relative Humidity :	49~51%
Test Voltage :	120Vac / 60Hz	Phase :	Neutral
Function Type :	GSM1900 (GPRS 8) Idle + WLAN Link + Bluetooth Link + RFID On + MPEG4 + TC3		
Remark :	All emissions not reported here are more than 10 dB below the prescribed limit. 13.558 MHz is fundamental signal of RFID/NFC which can be ignored.		

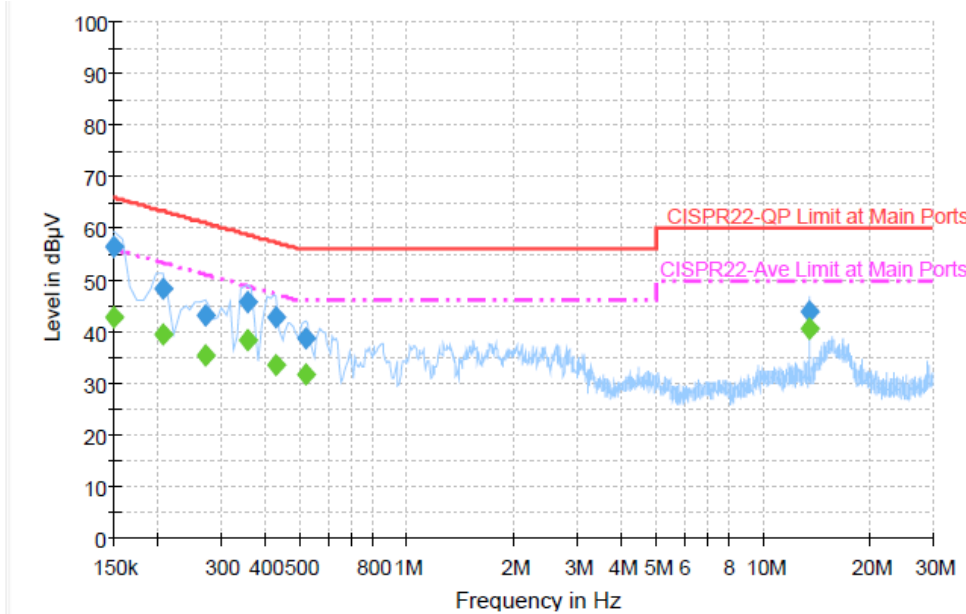

Final Result : Quasi-Peak

Frequency (MHz)	Quasi-Peak (dBµV)	Filter	Line	Corr. (dB)	Margin (dB)	Limit (dBµV)
0.150000	56.6	Off	N	19.4	9.4	66.0
0.206000	48.4	Off	N	19.4	15.0	63.4
0.270000	43.3	Off	N	19.4	17.8	61.1
0.358000	45.6	Off	N	19.4	13.2	58.8
0.430000	42.9	Off	N	19.4	14.4	57.3
0.518000	38.8	Off	N	19.4	17.2	56.0
13.558000	43.9	Off	N	19.9	16.1	60.0

Final Result : Average

Frequency (MHz)	Average (dBµV)	Filter	Line	Corr. (dB)	Margin (dB)	Limit (dBµV)
0.150000	42.8	Off	N	19.4	13.2	56.0
0.206000	39.6	Off	N	19.4	13.8	53.4
0.270000	35.4	Off	N	19.4	15.7	51.1
0.358000	38.3	Off	N	19.4	10.5	48.8
0.430000	33.7	Off	N	19.4	13.6	47.3
0.518000	31.6	Off	N	19.4	14.4	46.0
13.558000	40.8	Off	N	19.9	9.2	50.0



3.7 Antenna Requirements

3.7.1 Standard Applicable

If directional gain of transmitting antennas is greater than 6dBi, the power shall be reduced by the same level in dB comparing to gain minus 6dBi. For the fixed point-to-point operation, the power shall be reduced by one dB for every 3 dB that the directional gain of the antenna exceeds 6 dBi. The use of a permanently attached antenna or of an antenna that uses a unique coupling to the intentional radiator shall be considered sufficient to comply with the FCC rule.

3.7.2 Antenna Connected Construction

Non-standard connector used.

3.7.3 Antenna Gain

The antenna peak gain of EUT is less than 6 dBi. Therefore, it is not necessary to reduce maximum peak output power limit.



4 List of Measuring Equipment

Instrument	Manufacturer	Model No.	Serial No.	Characteristics	Calibration Date	Test Date	Due Date	Remark
Spectrum Analyzer	R&S	FSP40	100055	9kHz~40GHz	Jun. 06, 2012	Jul. 30, 2012 ~ Aug. 20, 2012	Jun. 05, 2013	Conducted (TH02-HY)
Power Meter	Anritsu	ML2495A	0932001	N/A	Sep. 18, 2011	Jul. 30, 2012 ~ Aug. 20, 2012	Sep. 17, 2012	Conducted (TH02-HY)
Power Sensor	Anritsu	MA2411B	0846202	N/A	Sep. 18, 2011	Jul. 30, 2012 ~ Aug. 20, 2012	Sep. 17, 2012	Conducted (TH02-HY)
Spectrum Analyzer	R&S	ESU26	100390	20Hz ~ 26.5GHz	Dec. 22, 2011	Aug. 23, 2012 ~ Aug. 24, 2012	Dec. 21, 2012	Radiation (03CH05-HY)
Bilog Antenna	SCHAFFNER	CBL6111C	2725	30MHz ~ 2GHz	Oct. 22, 2011	Aug. 23, 2012 ~ Aug. 24, 2012	Oct. 21, 2012	Radiation (03CH05-HY)
Turn Table	HD	Deis HD 2000	420/611	0 ~ 360 degree	N/A	Aug. 23, 2012 ~ Aug. 24, 2012	N/A	Radiation (03CH05-HY)
Antenna Mast	HD	MA 240	240/666	1 m ~ 4 m	N/A	Aug. 23, 2012 ~ Aug. 24, 2012	N/A	Radiation (03CH05-HY)
Horn Antenna	ESCO	3117	66584	1GHz~18GHz	Aug. 10, 2012	Aug. 23, 2012 ~ Aug. 24, 2012	Aug. 09, 2013	Radiation (03CH05-HY)
Pre Amplifier	COM-POWER	PA-103A	161075	10Hz ~ 1000MHz Gain:32dB	Feb. 27, 2012	Aug. 23, 2012 ~ Aug. 24, 2012	Feb. 26, 2013	Radiation (03CH05-HY)
Pre Amplifier	MITEQ	AMF-7D-00 101800-30-10P	159087	1GHz~18GHz	Feb. 27, 2012	Aug. 23, 2012 ~ Aug. 24, 2012	Feb. 26, 2013	Radiation (03CH05-HY)
Pre Amplifier	Agilent	8449B	3008A01917	1GHz~26.5GHz	Aug. 30, 2011	Aug. 23, 2012 ~ Aug. 24, 2012	Aug. 29, 2012	Radiation (03CH05-HY)
SHF-EHF Horn Antenna	SCHWARZBECK	BBHA 9170	BBHA917025 1	15GHz ~ 40GHz	Oct. 21, 2011	Aug. 23, 2012 ~ Aug. 24, 2012	Oct. 20, 2012	Radiation (03CH05-HY)
Loop Antenna	R&S	HFH2-Z2	860004/001	9KHz ~ 30MHz	Jul. 03, 2012	Aug. 23, 2012 ~ Aug. 24, 2012	Jul. 02, 2014	Radiation (03CH05-HY)
EMI Test Receiver	R&S	ESCS 30	100356	9KHz ~ 2.75GHz	Oct. 27, 2011	Jul. 13, 2012 ~ Aug. 29, 2012	Oct. 26, 2012	Conduction (CO05-HY)
Two-LISN	R&S	ENV216	11-100081	9KHz ~ 30MHz	Dec. 09, 2011	Jul. 23, 2012 ~ Aug. 29, 2012	Dec. 08, 2012	Conduction (CO05-HY)
Two-LISN	R&S	ENV216	11-100080	9KHz ~ 30MHz	Dec. 06, 2011	Jul. 23, 2012 ~ Aug. 29, 2012	Dec. 05, 2012	Conduction (CO05-HY)
AC Power Source	APC	APC-1000 W	N/A	N/A	N/A	Jul. 23, 2012 ~ Aug. 29, 2012	N/A	Conduction (CO05-HY)
System Simulator	R&S	CMU200	117997	N/A	Aug. 22, 2011	Jul. 23, 2012 ~ Aug. 29, 2012	Aug. 21, 2013	Conduction (CO05-HY)



5 Uncertainty of Evaluation

Uncertainty of Conducted Emission Measurement (150 KHz ~ 30 MHz)

Measuring Uncertainty for a Level of Confidence of 95% ($U = 2Uc(y)$)	2.26
-------------------------------------------------------------------------	------

Uncertainty of Radiated Emission Measurement (30 MHz ~ 1000 MHz)

Measuring Uncertainty for a Level of Confidence of 95% ($U = 2Uc(y)$)	2.54
-------------------------------------------------------------------------	------

Uncertainty of Radiated Emission Measurement (1 GHz ~ 40 GHz)

Measuring Uncertainty for a Level of Confidence of 95% ($U = 2Uc(y)$)	4.72
-------------------------------------------------------------------------	------



Appendix A. Photographs of EUT

Please refer to Sporton report number EP262032 as below.