

Test Data

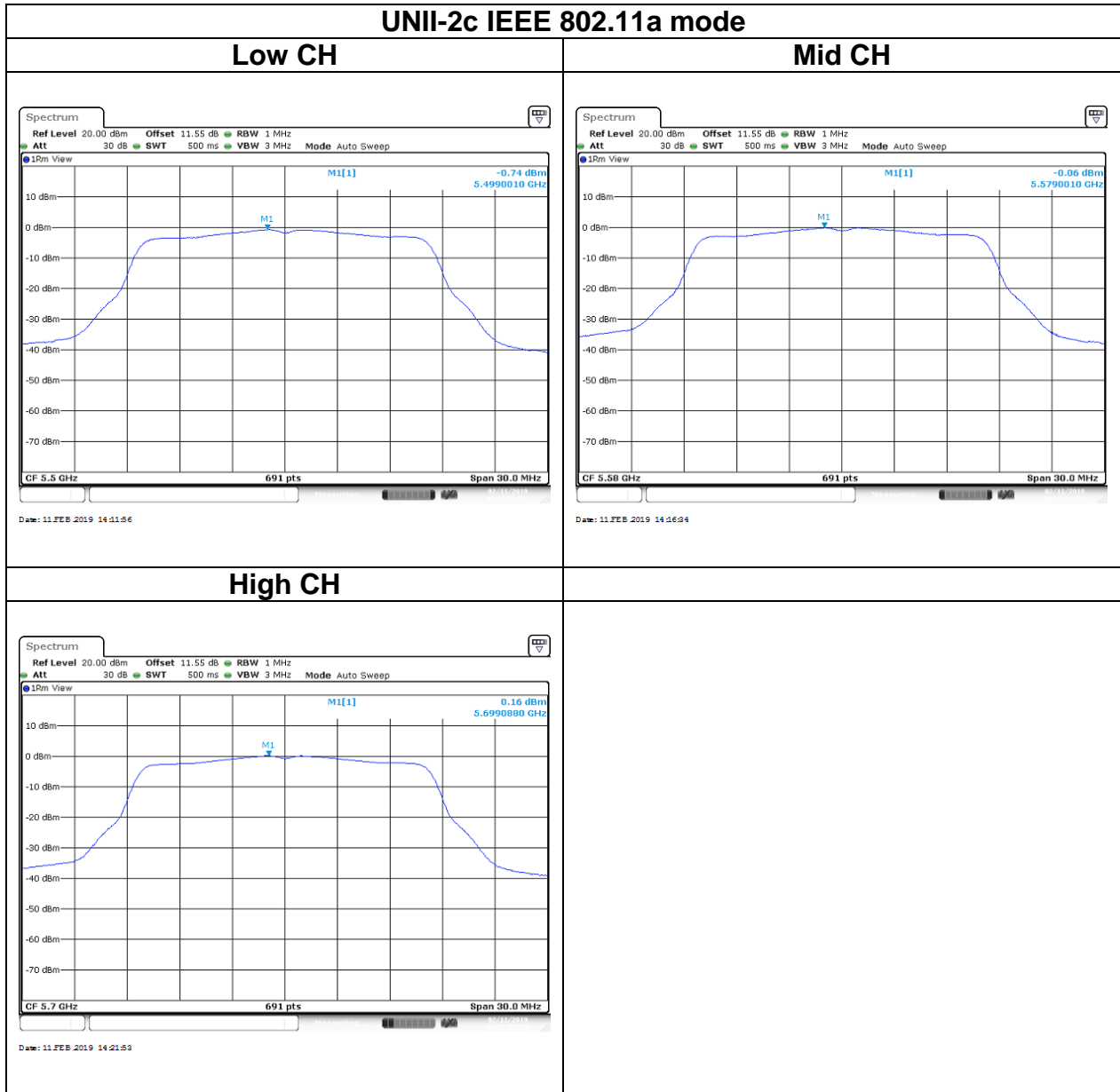

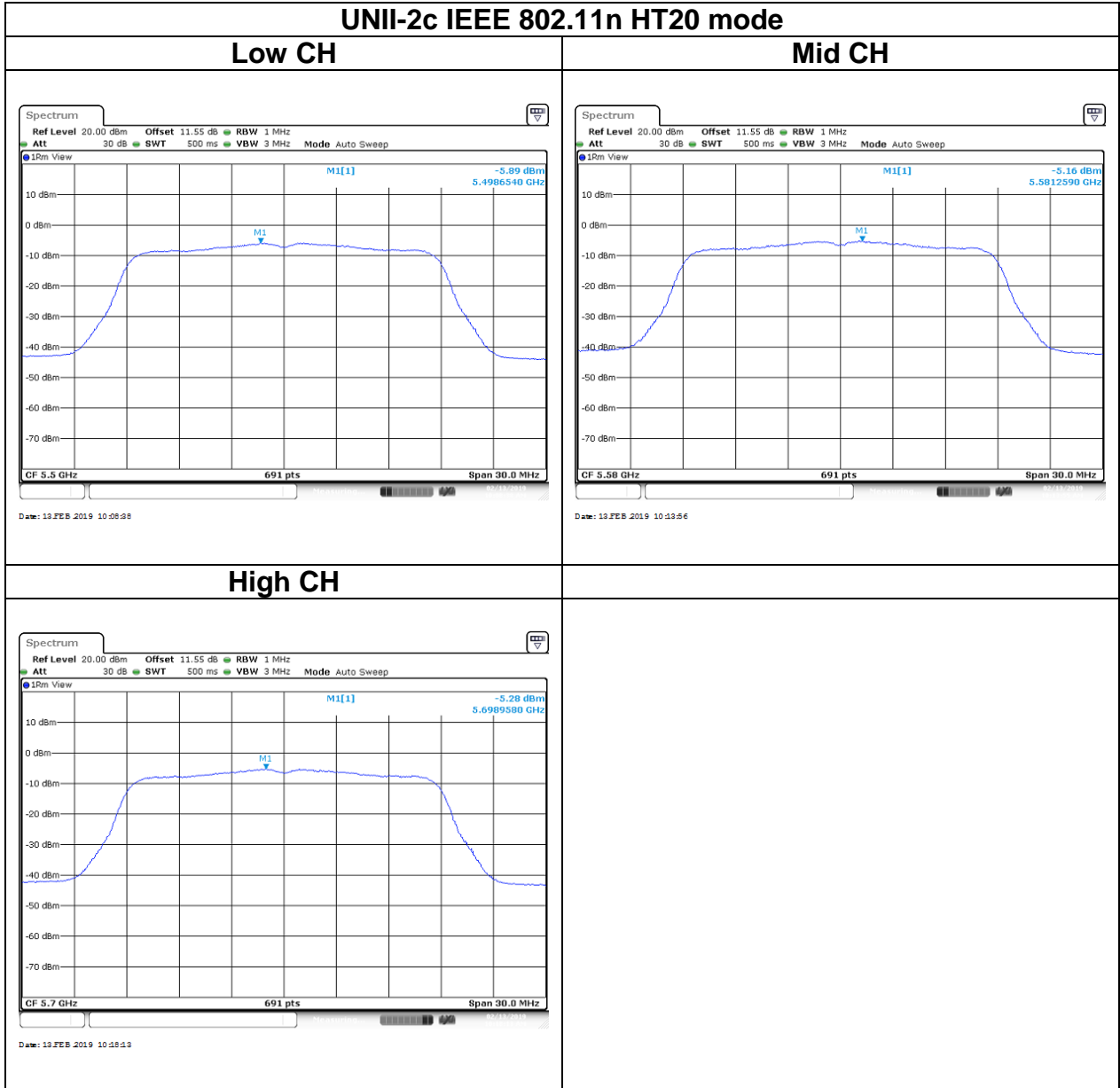

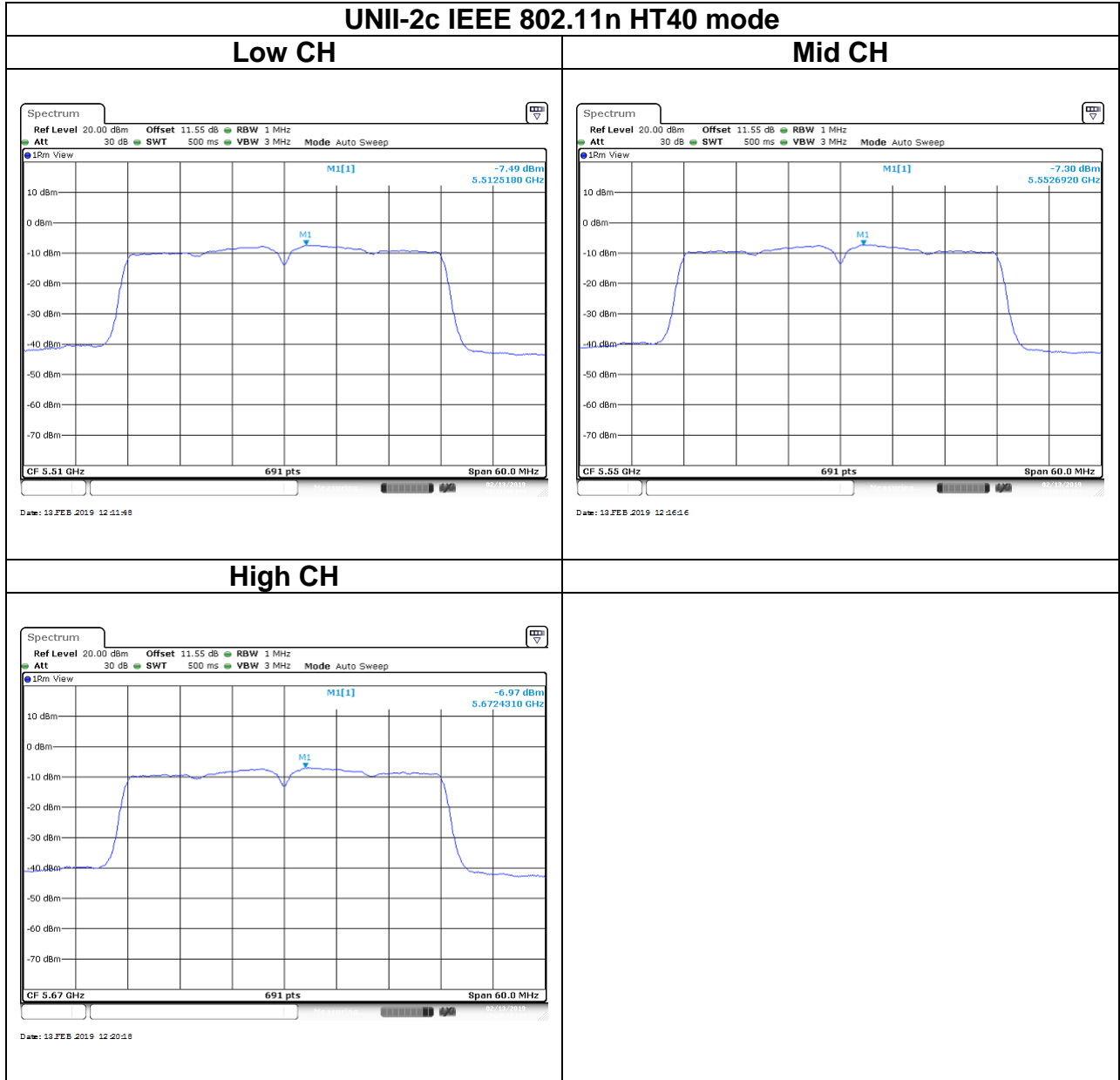

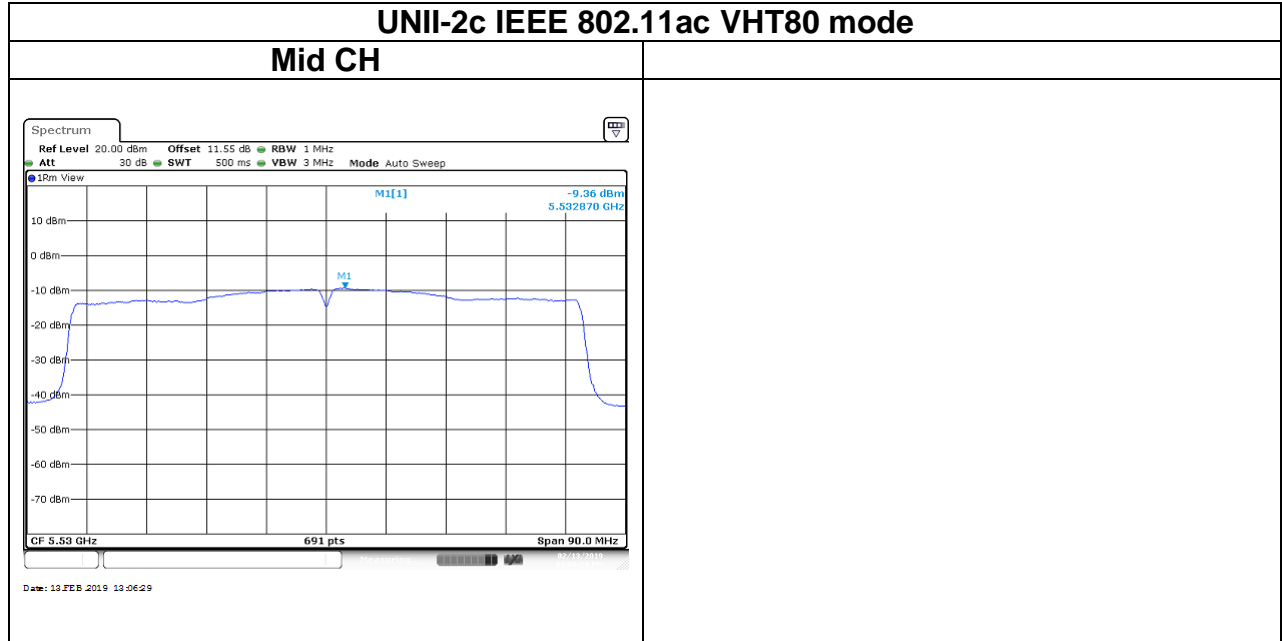

Test Data

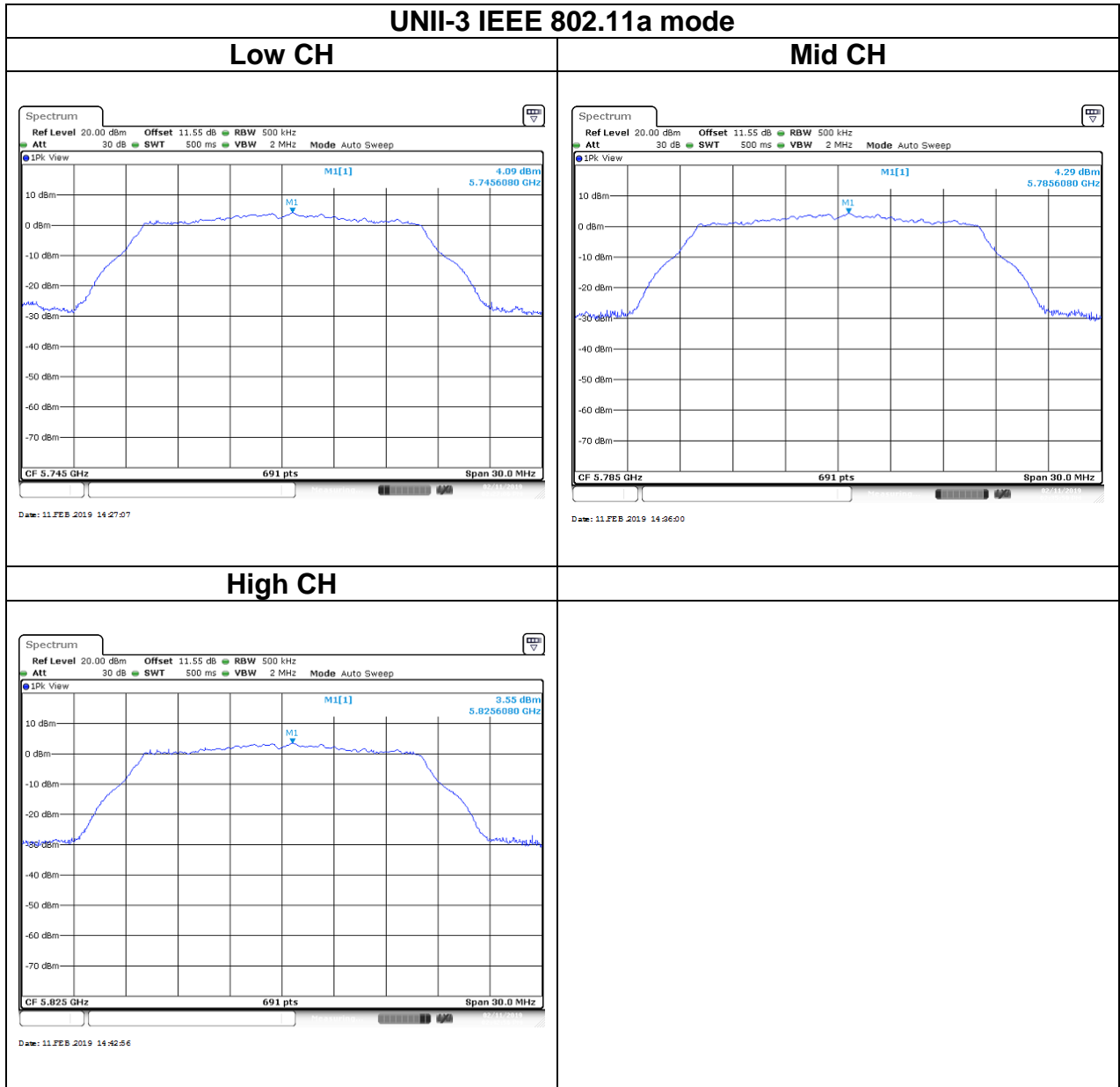

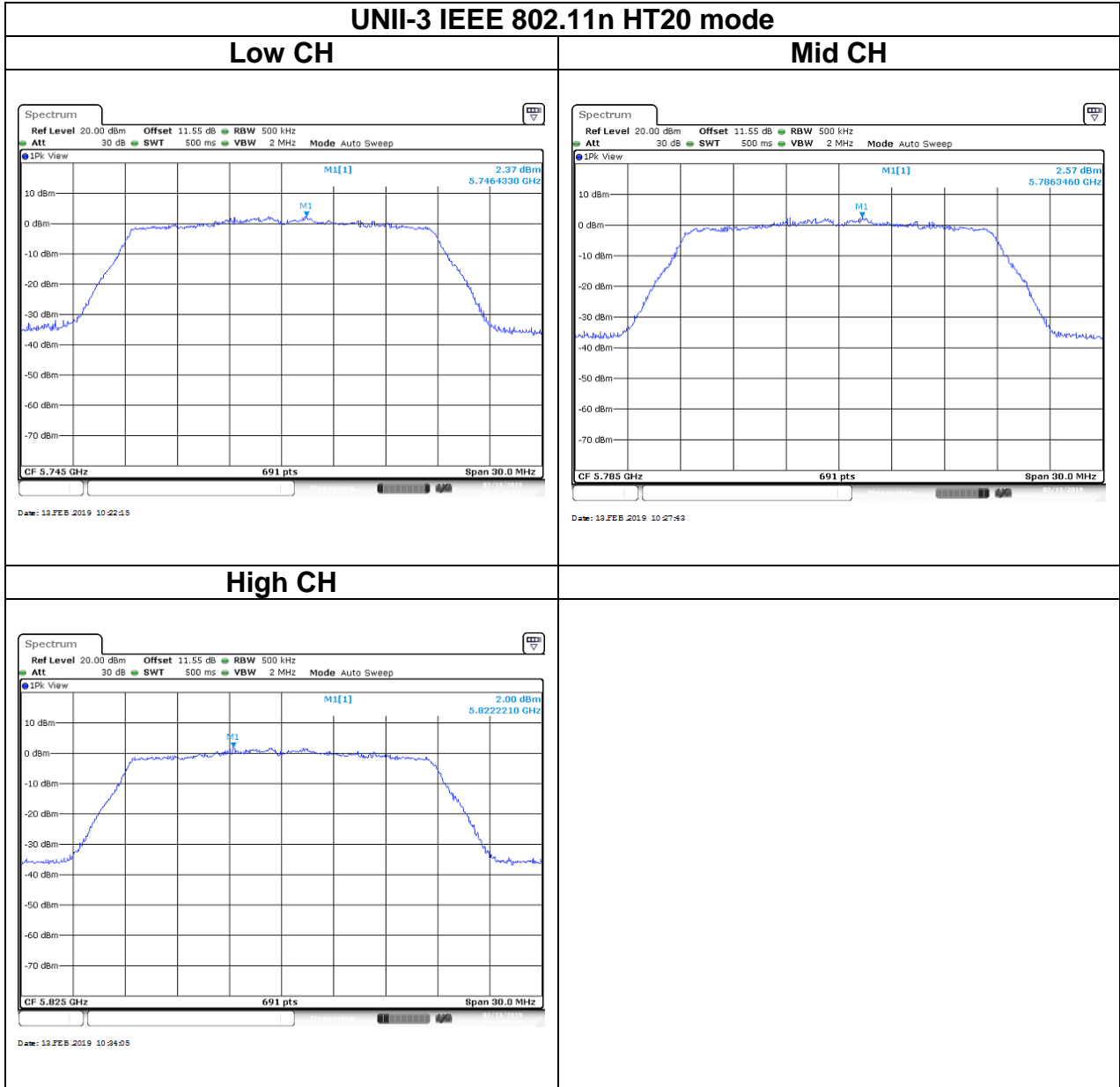

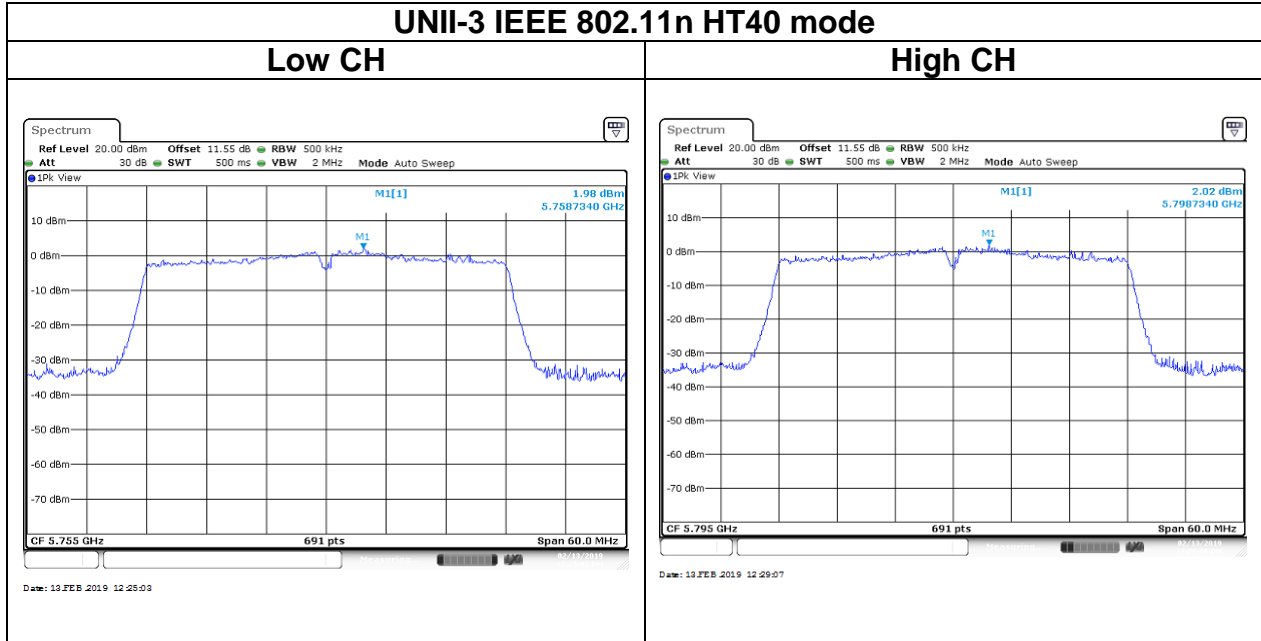

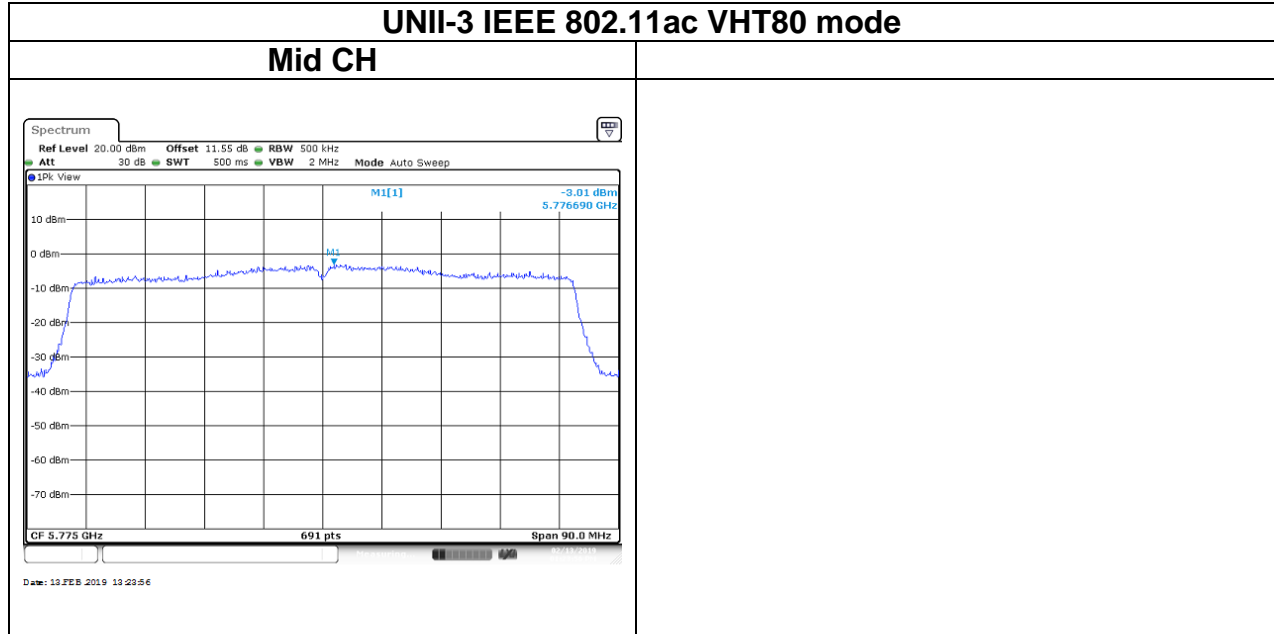

4.5 RADIATION BANDEDGE AND SPURIOUS EMISSION

4.5.1 Test Limit

FCC according to §15.407, §15.209 and §15.205,

Below 30 MHz

Frequency	Field Strength (microvolts/m)	Magnetic H-Field (microamperes/m)	Measurement Distance (metres)
9-490 kHz	2,400/F (F in kHz)	2,400/F (F in kHz)	300
490-1,705 kHz	24,000/F (F in kHz)	24,000/F (F in kHz)	30
1.705-30 MHz	30	N/A	30

Above 30 MHz

Frequency (MHz)	Field Strength microvolts/m at 3 metres (watts, e.i.r.p.)	
	Transmitters	Receivers
30-88	100 (3 nW)	100 (3 nW)
88-216	150 (6.8 nW)	150 (6.8 nW)
216-960	200 (12 nW)	200 (12 nW)
Above 960	500 (75 nW)	500 (75 nW)

IC according to RSS-247 section 6.2.1(2), section 6.2.2(2), section 6.2.3(2) and section 6.2.4(2)

UNII-1 :

For transmitters operating in the band 5150-5250 MHz, all emissions outside the band 5150-5350 MHz shall not exceed -27 dBm/MHz e.i.r.p. However, any unwanted emissions that fall into the band 5250-5350 MHz must be 26 dBc, when measured using a resolution bandwidth between 1 and 5% of the occupied bandwidth, above 5.25 GHz. Otherwise, the transmission is considered as intentional and the devices shall implement dynamic frequency selection (DFS) and transmitter power control (TPC) as per the requirements for the band 5250-5350 MHz

UNII-2a and 2c :

For devices with operating frequencies in the band 5250-5350 MHz but having a channel bandwidth that overlaps the band 5150-5250 MHz, the devices' unwanted emission shall not exceed -27 dBm/MHz e.i.r.p. outside the band 5150-5350 MHz and its power shall comply with the spectral power density for operation within the band 5150-5250 MHz. The device shall be labelled "for indoor use only." Emissions outside the band 5470-5725 MHz shall not exceed -27 dBm/MHz e.i.r.p.

UNII-3:

All emissions shall be limited to a level of -27 dBm/MHz at 75 MHz or more above or below the band edge increasing linearly to 10 dBm/MHz at 25 MHz above or below the band edge, and from 25 MHz above or below the band edge increasing linearly to a level of 15.6 dBm/MHz at 5 MHz above or below the band edge, and from 5 MHz above or below the band edge increasing linearly to a level of 27 dBm/MHz at the band edge.

4.5.2 Test Procedure

Test method Refer as KDB 789033 D02 v02r01, Section G.3, G.4, G.5, and G.6,.

1. The EUT is placed on a turntable, Above 1 GHz is 1.5m and below 1 GHz is 0.8m above ground plane. The EUT Configured un accordance with ANSI C63.10: 2013, and the EUT set in a continuous mode.
2. The turntable shall be rotated for 360 degrees to determine the position of maximum emission level. And EUT is set 3m away from the receiving antenna, which is scanned from 1m to 4m above the ground plane to find out the highest emissions. Measurement are made polarized in both the vertical and the horizontal positions with antenna.
3. Span shall wide enough to full capture the emission measured. The SA from 9kHz to 26.5GHz set to the low, Mid and High channels with the EUT transmit.
4. No emission found between lowest internal used/generated frequency to 30MHz (9KHz~30MHz)
5. The SA setting following :
 - (1) Below 1G : RBW = 100kHz, VBW $\geq 3 \times$ RBW, Sweep = Auto, Detector = Peak, Trace = Max hold.
 - (2) Above 1G :
 - (2.1) For Peak measurement : RBW = 1MHz, VBW ≥ 3 RBW, Sweep = Auto, Detector = Peak, Trace = Max hold.
 - (2.2) For Average measurement : RBW = 1MHz, VBW
 - 'If Duty Cycle $\geq 98\%$, VBW=10Hz.
 - 'If Duty Cycle $< 98\%$, VBW=1/T.

Configuration	Duty Cycle (%)	T(ms)	1/T (Hz)	VBW Setting
802.11a	95.33%	1.4300	0.699	750Hz
802.11n HT20	95.00%	1.3300	0.752	820Hz
802.11n HT40	89.33%	670.0000	0.001	1.5kHz
802.11ac VHT80	83.33%	350.0000	0.003	3kHz

4.5.3 Test Setup

9kHz ~ 30MHz

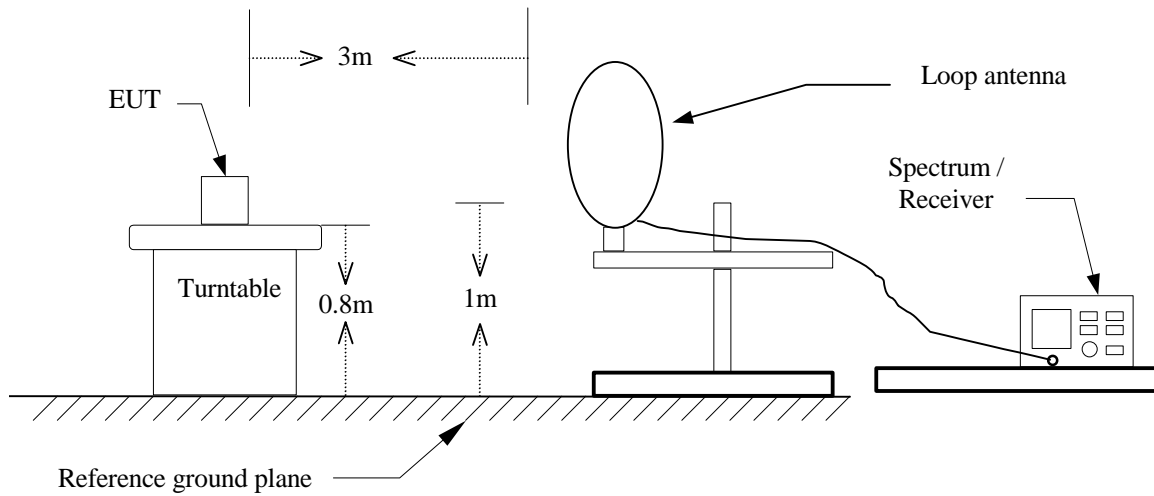

30MHz ~ 1GHz

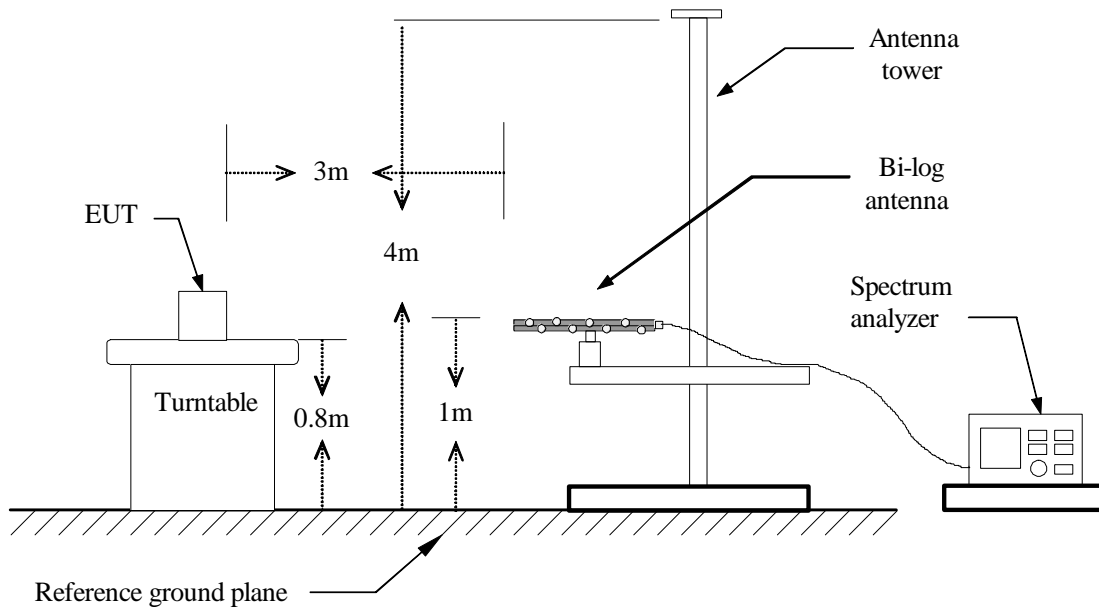

Above 1 GHz

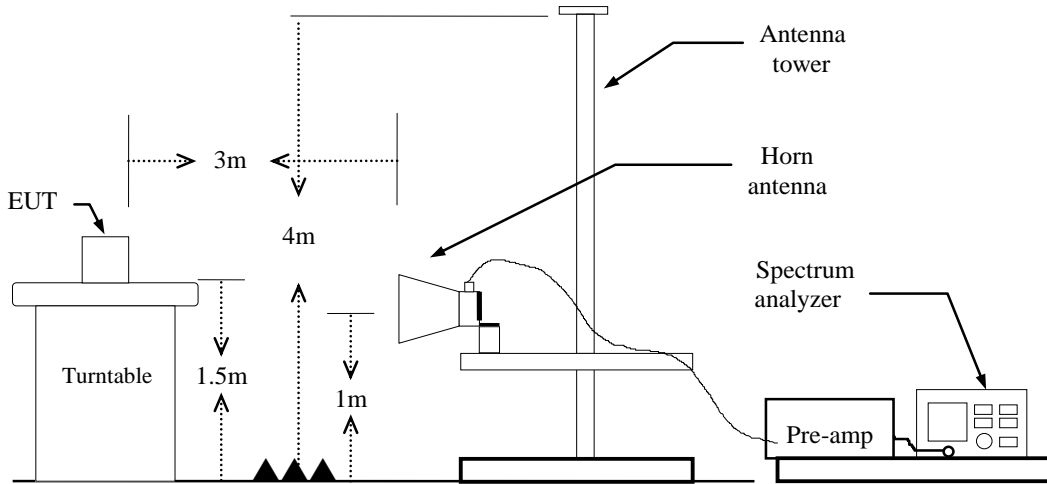

4.5.4 Test Result

Test Data

Band Edge Test Data for UNII-1

Test Mode	IEEE 802.11a / 5180MHZ	Temp/Hum	22.3(°C)/ 51%RH
Test Item	Band Edge	Test Date	February 12, 2019
Polarize	Vertical	Test Engineer	Jerry Chuang
Detector	Peak		

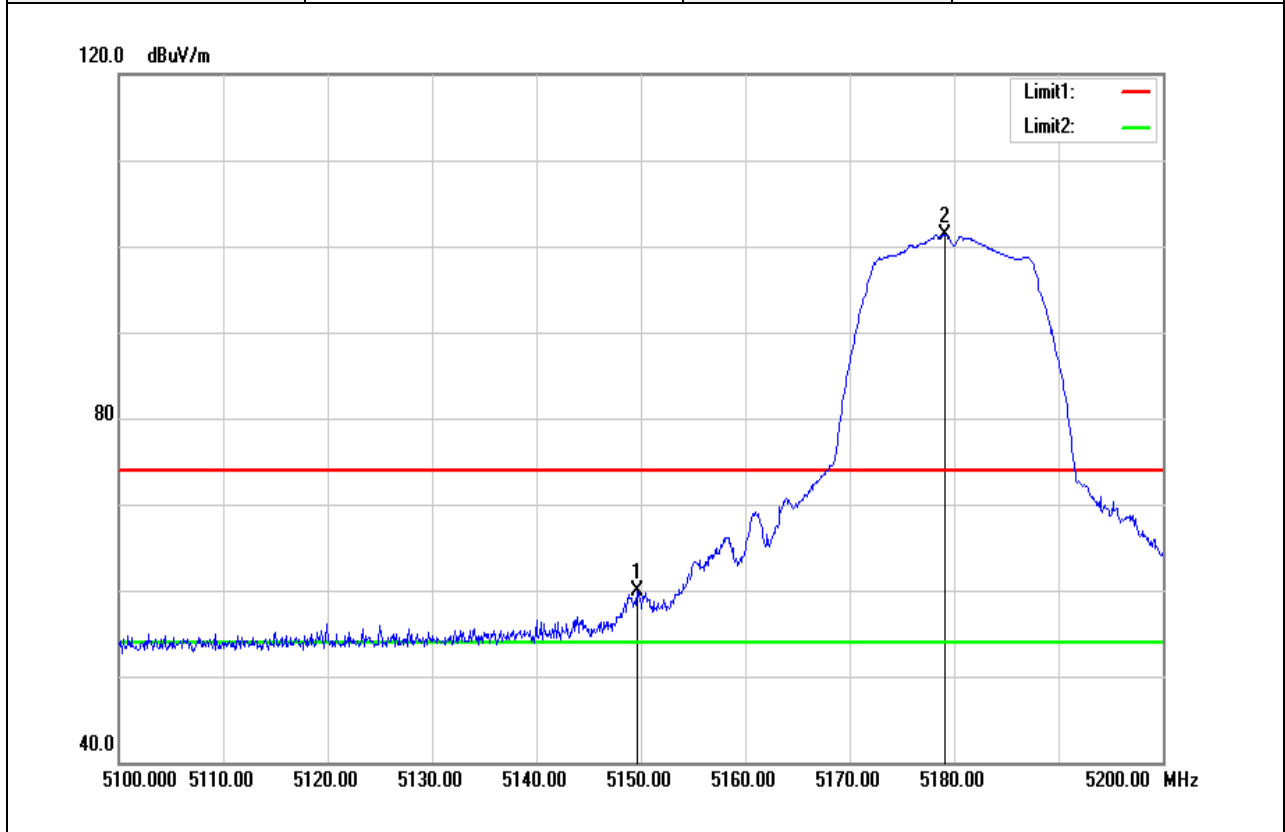

Frequency (MHz)	Reading (dBuV)	Correct Factor (dB/m)	Result (dBuV/m)	Limit (dBuV/m)	Margin (dB)	Remark
5149.600	54.92	5.00	59.92	74.00	-14.08	peak
5179.100	96.21	5.12	101.33	-	-	peak

Test Mode	IEEE 802.11a / 5180MHZ	Temperature	22.3(°C)/ 51%RH
Test Item	Band Edge	Test Date	February 12, 2019
Polarize	Vertical	Test Engineer	Jerry Chuang
Detector	Average		

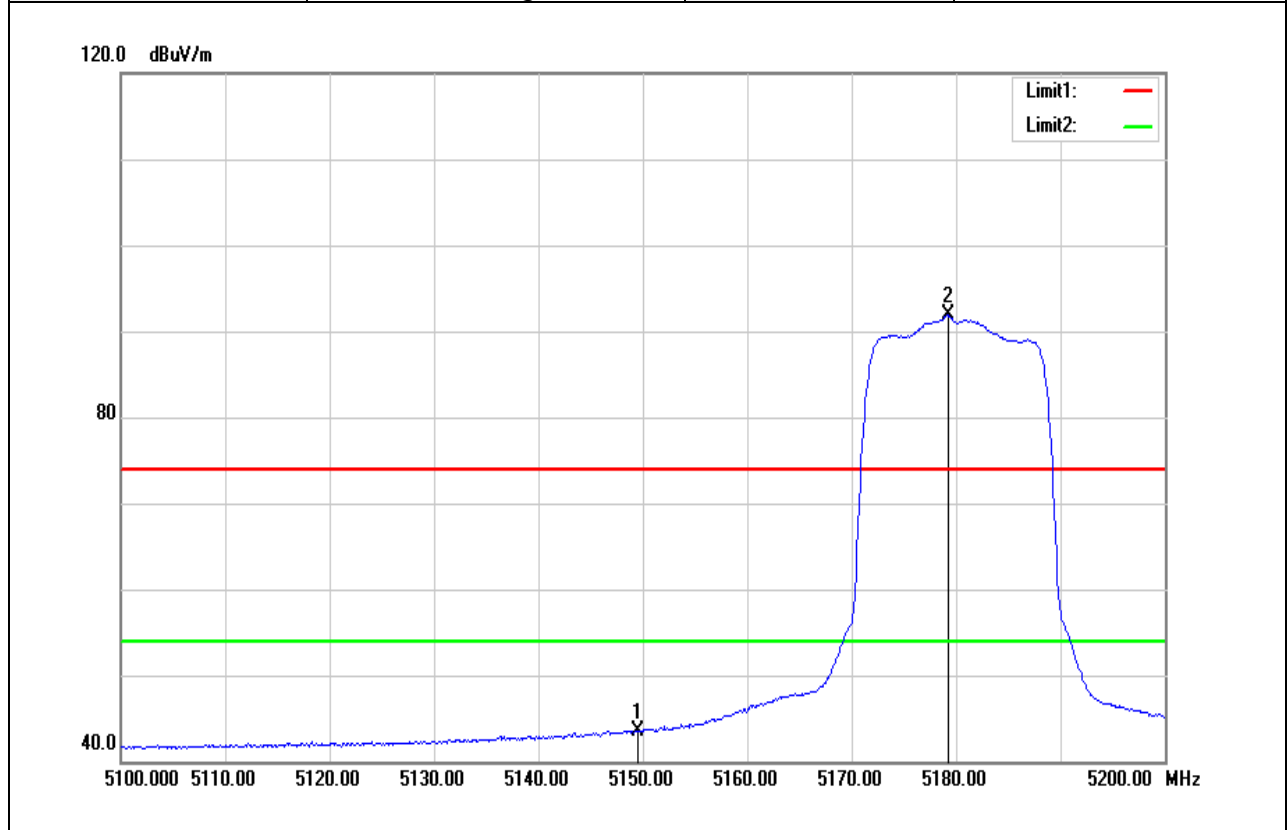

Frequency (MHz)	Reading (dBuV)	Correct Factor (dB/m)	Result (dBuV/m)	Limit (dBuV/m)	Margin (dB)	Remark
5149.500	38.58	5.00	43.58	54.00	-10.42	AVG
5179.200	86.77	5.12	91.89	-	-	AVG

Test Mode	IEEE 802.11a / 5240MHZ	Temp/Hum	22.3(°C)/ 51%RH
Test Item	Band Edge	Test Date	February 12, 2019
Polarize	Vertical	Test Engineer	Jerry Chuang
Detector	Peak		

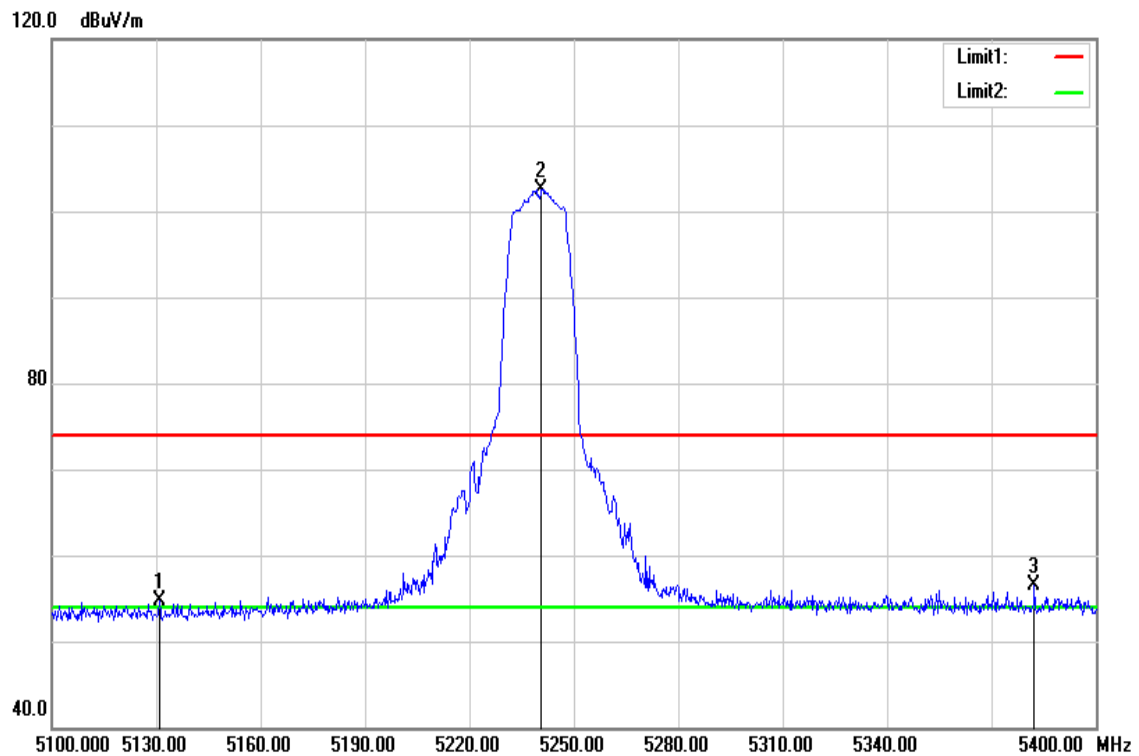

Frequency (MHz)	Reading (dBuV)	Correct Factor (dB/m)	Result (dBuV/m)	Limit (dBuV/m)	Margin (dB)	Remark
5130.900	49.71	4.92	54.63	74.00	-19.37	peak
5240.700	97.35	5.24	102.59	-	-	peak
5382.300	51.16	5.39	56.55	74.00	-17.45	peak

Test Mode	IEEE 802.11a / 5240MHZ	Temp/Hum	22.3(°C)/ 51%RH
Test Item	Band Edge	Test Date	February 12, 2019
Polarize	Vertical	Test Engineer	Jerry Chuang
Detector	Average		

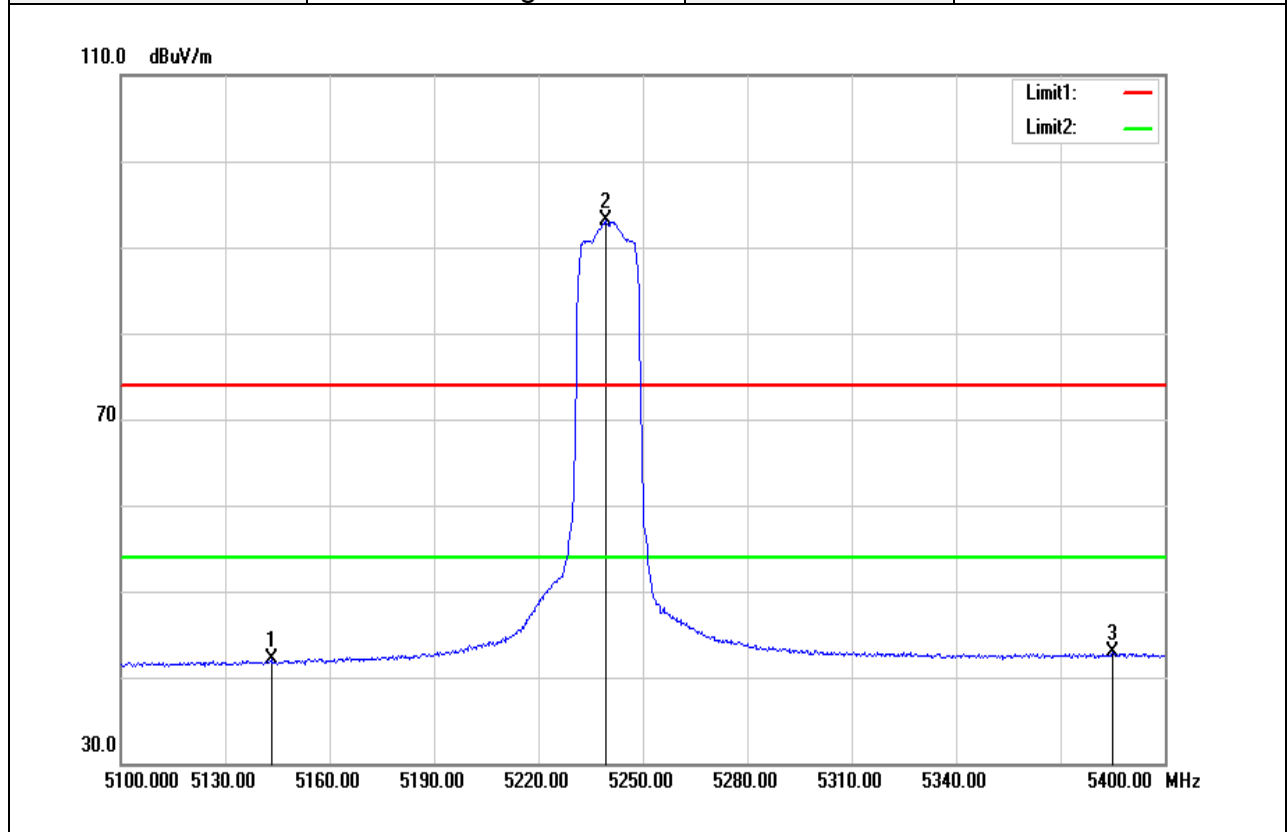

Frequency (MHz)	Reading (dBuV)	Correct Factor (dB/m)	Result (dBuV/m)	Limit (dBuV/m)	Margin (dB)	Remark
5143.200	37.07	4.98	42.05	54.00	-11.95	AVG
5239.200	87.84	5.24	93.08	-	-	AVG
5385.000	37.44	5.39	42.83	54.00	-11.17	AVG

Test Mode	IEEE 802.11n HT20 / 5180MHZ	Temp/Hum	23.2(°C)/ 52%RH
Test Item	Band Edge	Test Date	February 15, 2019
Polarize	Vertical	Test Engineer	Jerry Chuang
Detector	Peak		

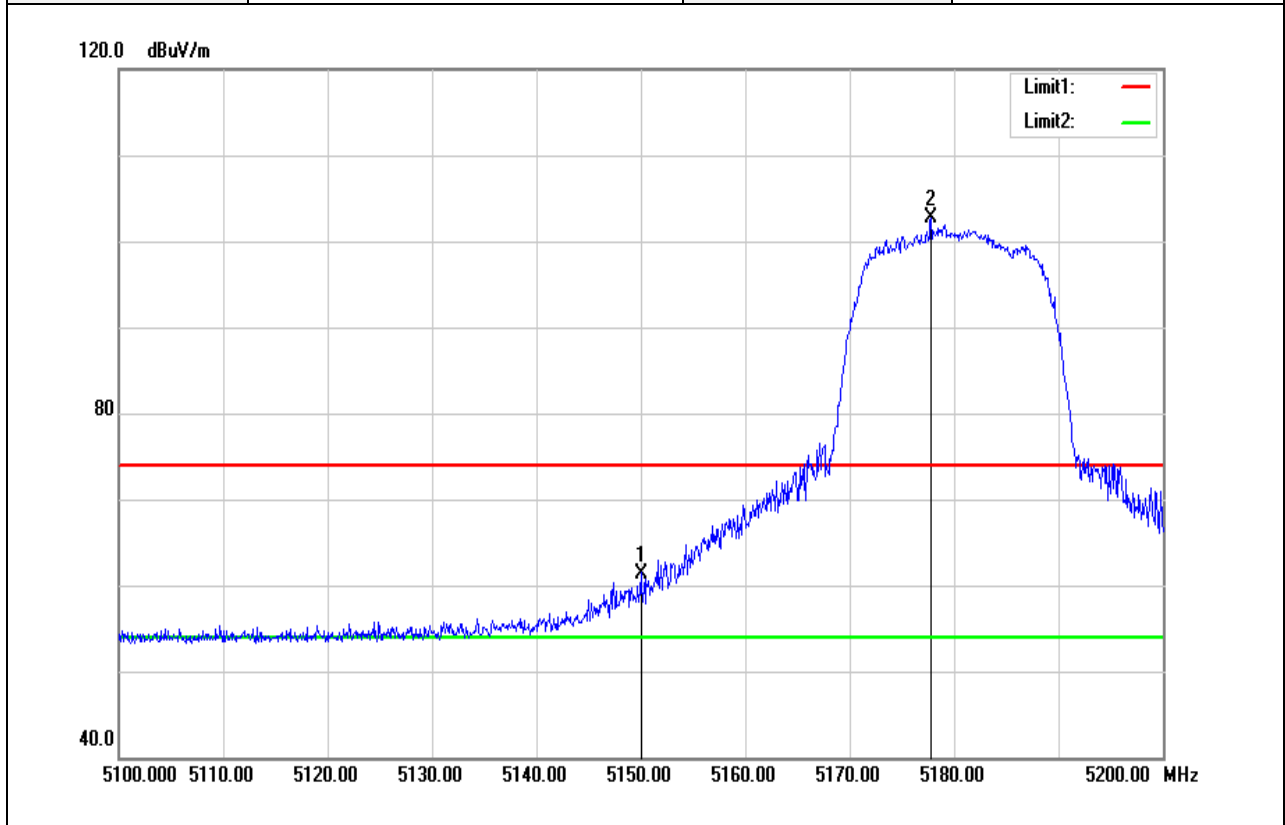

Frequency (MHz)	Reading (dBuV)	Correct Factor (dB/m)	Result (dBuV/m)	Limit (dBuV/m)	Margin (dB)	Remark
5150.000	56.40	5.00	61.40	74.00	-12.60	peak
5177.800	97.56	5.12	102.68	-	-	peak

Test Mode	IEEE 802.11n HT20 / 5180MHZ	Temp/Hum	23.2(°C)/ 52%RH
Test Item	Band Edge	Test Date	February 15, 2019
Polarize	Vertical	Test Engineer	Jerry Chuang
Detector	Average		

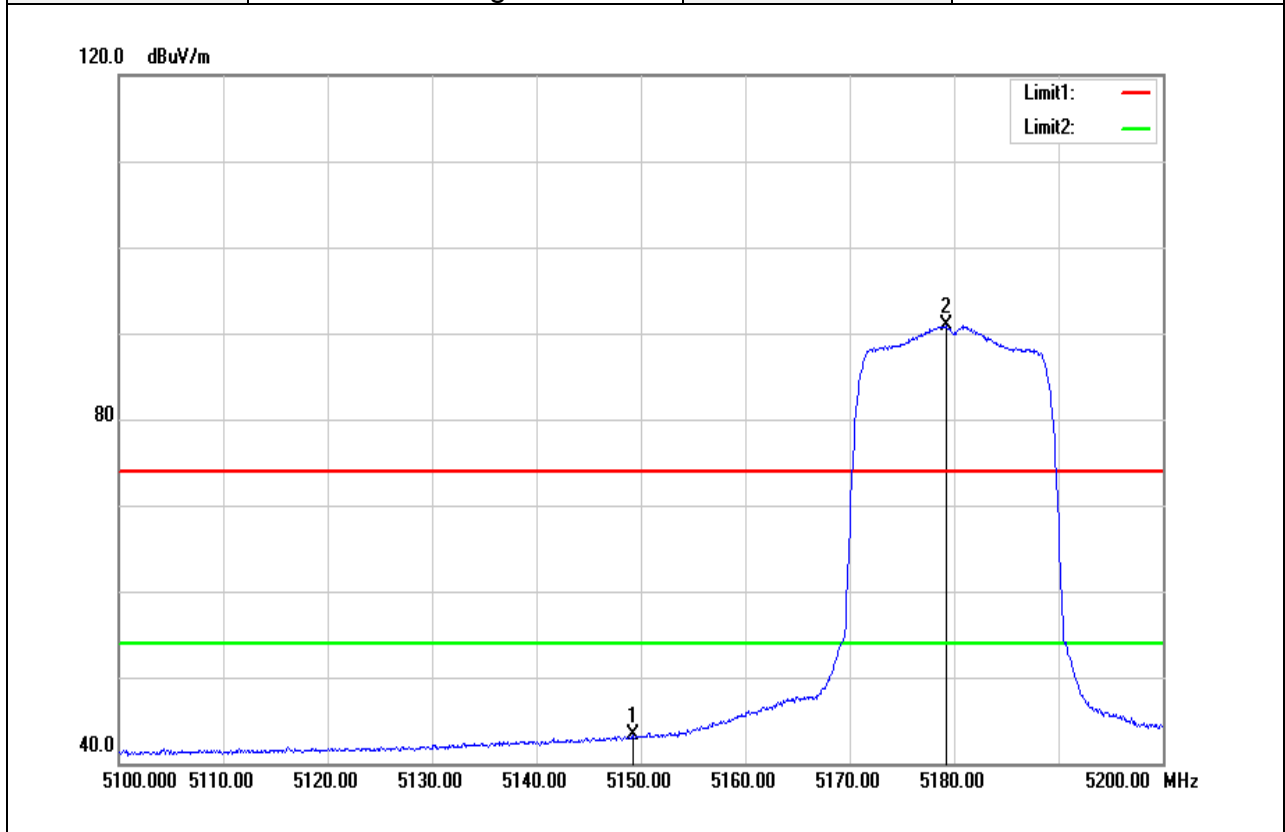

Frequency (MHz)	Reading (dBuV)	Correct Factor (dB/m)	Result (dBuV/m)	Limit (dBuV/m)	Margin (dB)	Remark
5149.300	38.38	5.00	43.38	54.00	-10.62	AVG
5179.200	85.76	5.12	90.88	-	-	AVG

Test Mode	IEEE 802.11n HT20 / 5240MHZ	Temp/Hum	23.2(°C)/ 52%RH
Test Item	Band Edge	Test Date	February 15, 2019
Polarize	Vertical	Test Engineer	Jerry Chuang
Detector	Peak		

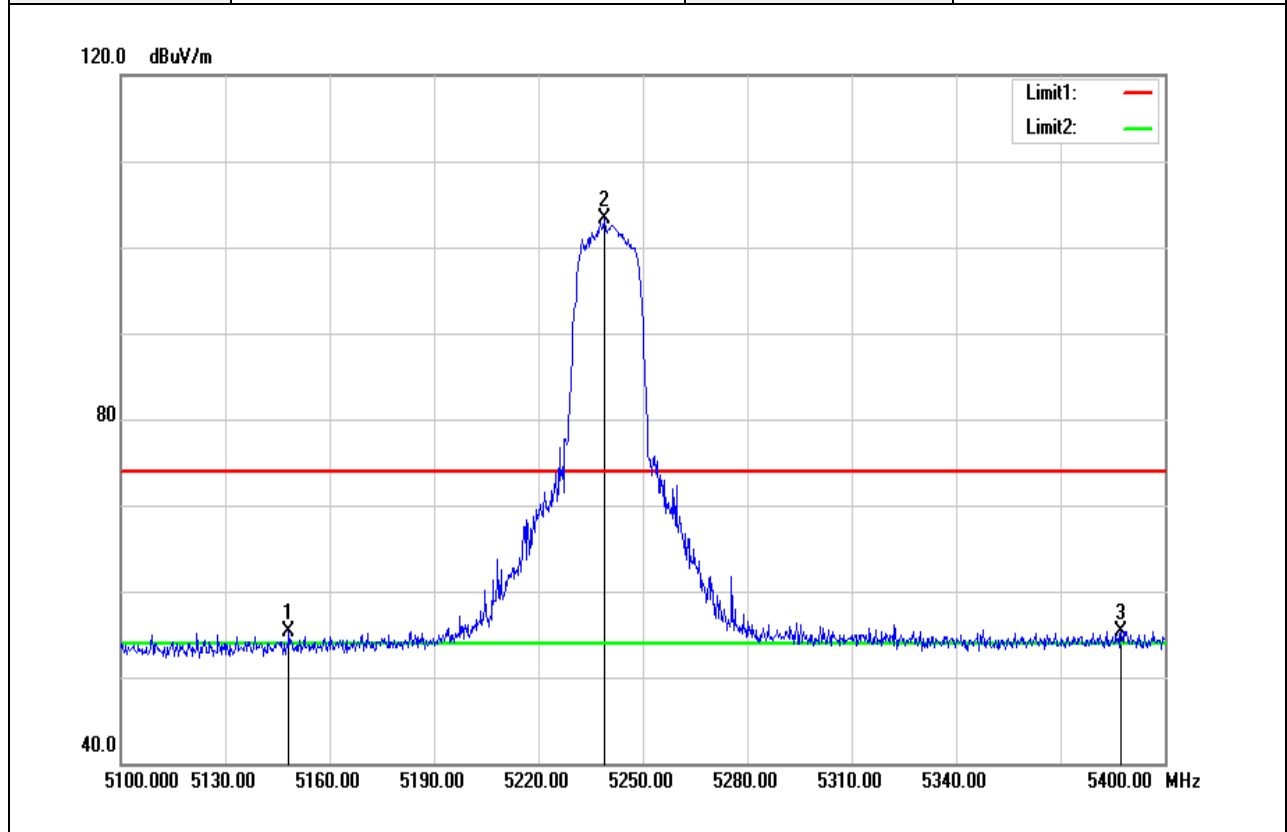

Frequency (MHz)	Reading (dBuV)	Correct Factor (dB/m)	Result (dBuV/m)	Limit (dBuV/m)	Margin (dB)	Remark
5148.300	50.31	5.00	55.31	74.00	-18.69	peak
5238.900	98.15	5.24	103.39	-	-	peak
5387.400	49.96	5.40	55.36	74.00	-18.64	peak

Test Mode	IEEE 802.11n HT20 / 5240MHZ	Temperature	23.2(°C)/ 52%RH
Test Item	Band Edge	Test Date	February 15, 2019
Polarize	Vertical	Test Engineer	Jerry Chuang
Detector	Average		

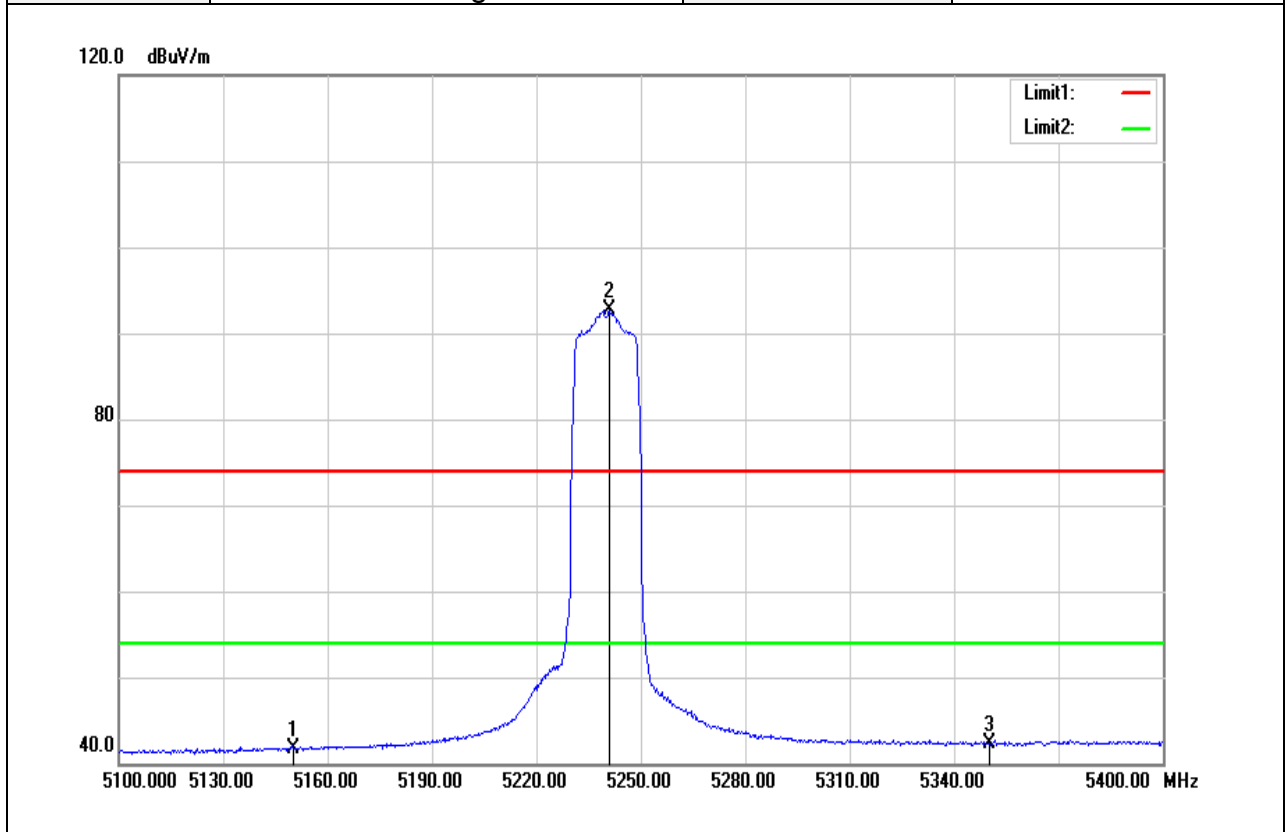

Frequency (MHz)	Reading (dBuV)	Correct Factor (dB/m)	Result (dBuV/m)	Limit (dBuV/m)	Margin (dB)	Remark
5150.000	36.73	5.00	41.73	54.00	-12.27	AVG
5241.000	87.37	5.25	92.62	-	-	AVG
5350.000	36.85	5.36	42.21	54.00	-11.79	AVG

Test Mode	IEEE 802.11n HT40 / 5190MHZ	Temp/Hum	23.2(°C)/ 52%RH
Test Item	Band Edge	Test Date	February 15, 2019
Polarize	Vertical	Test Engineer	Jerry Chuang
Detector	Peak		

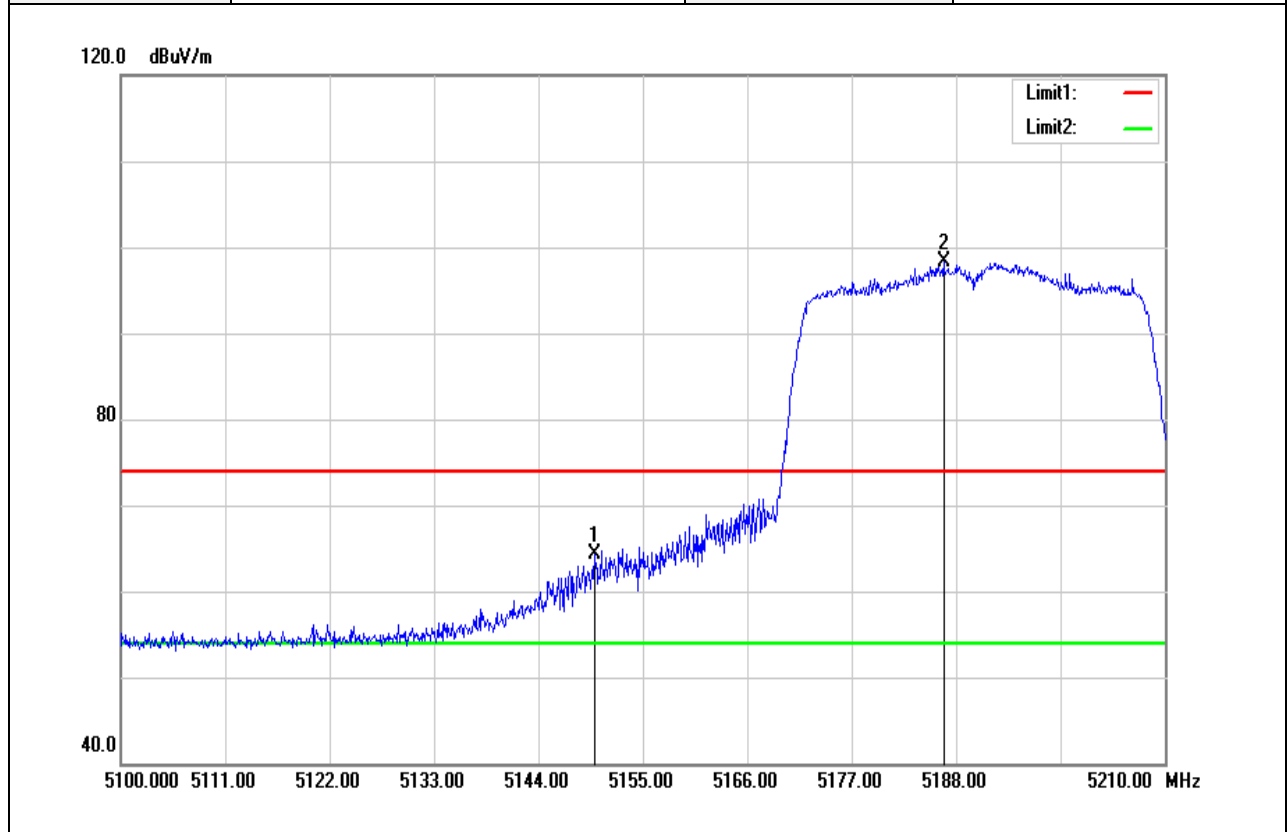

Frequency (MHz)	Reading (dBuV)	Correct Factor (dB/m)	Result (dBuV/m)	Limit (dBuV/m)	Margin (dB)	Remark
5149.940	59.23	5.00	64.23	74.00	-9.77	peak
5186.680	93.16	5.15	98.31	-	-	peak

Test Mode	IEEE 802.11n HT40 / 5190MHZ	Temperature	23.2(°C)/ 52%RH
Test Item	Band Edge	Test Date	February 15, 2019
Polarize	Vertical	Test Engineer	Jerry Chuang
Detector	Average		

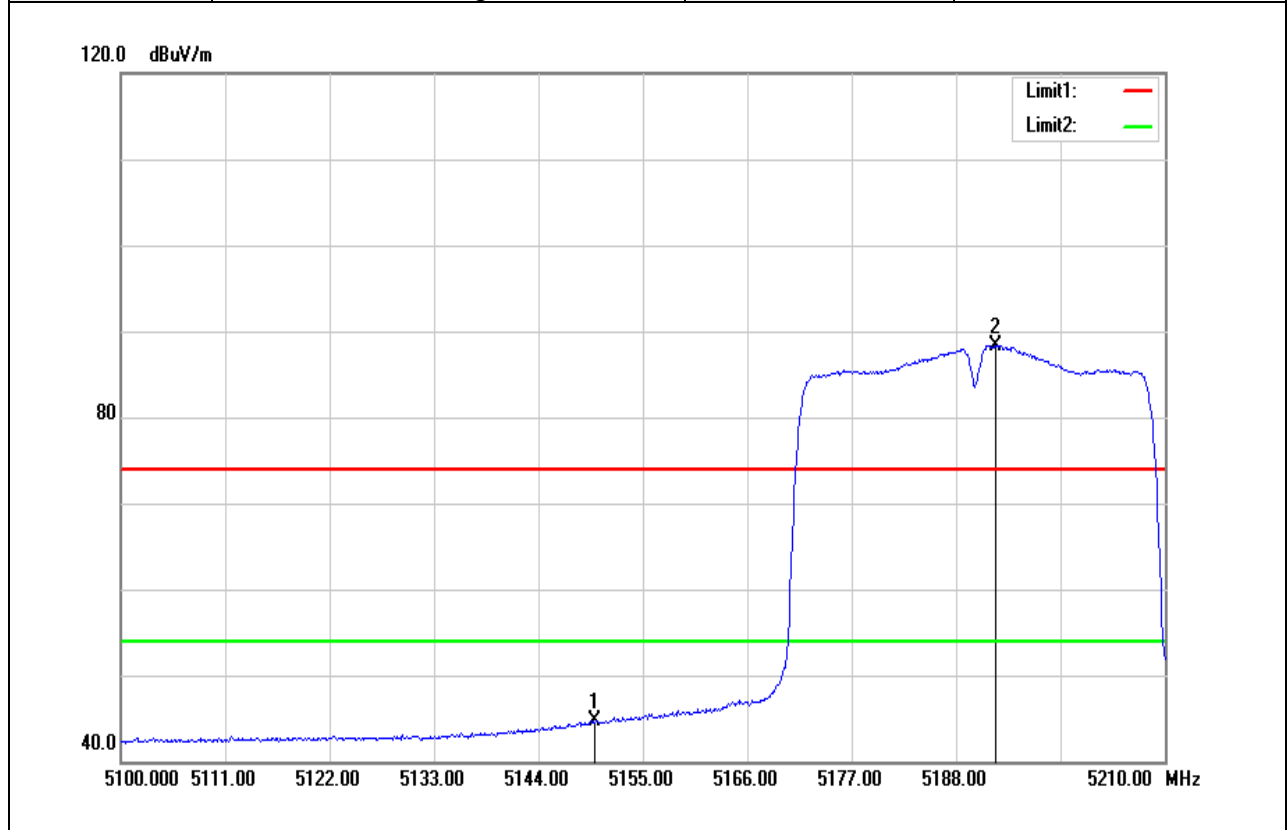

Frequency (MHz)	Reading (dBuV)	Correct Factor (dB/m)	Result (dBuV/m)	Limit (dBuV/m)	Margin (dB)	Remark
5150.000	39.76	5.00	44.76	54.00	-9.24	AVG
5192.180	83.14	5.17	88.31	-	-	AVG

Test Mode	IEEE 802.11n HT40 / 5230MHZ	Temp/Hum	23.2(°C)/ 52%RH
Test Item	Band Edge	Test Date	February 15, 2019
Polarize	Vertical	Test Engineer	Jerry Chuang
Detector	Peak		

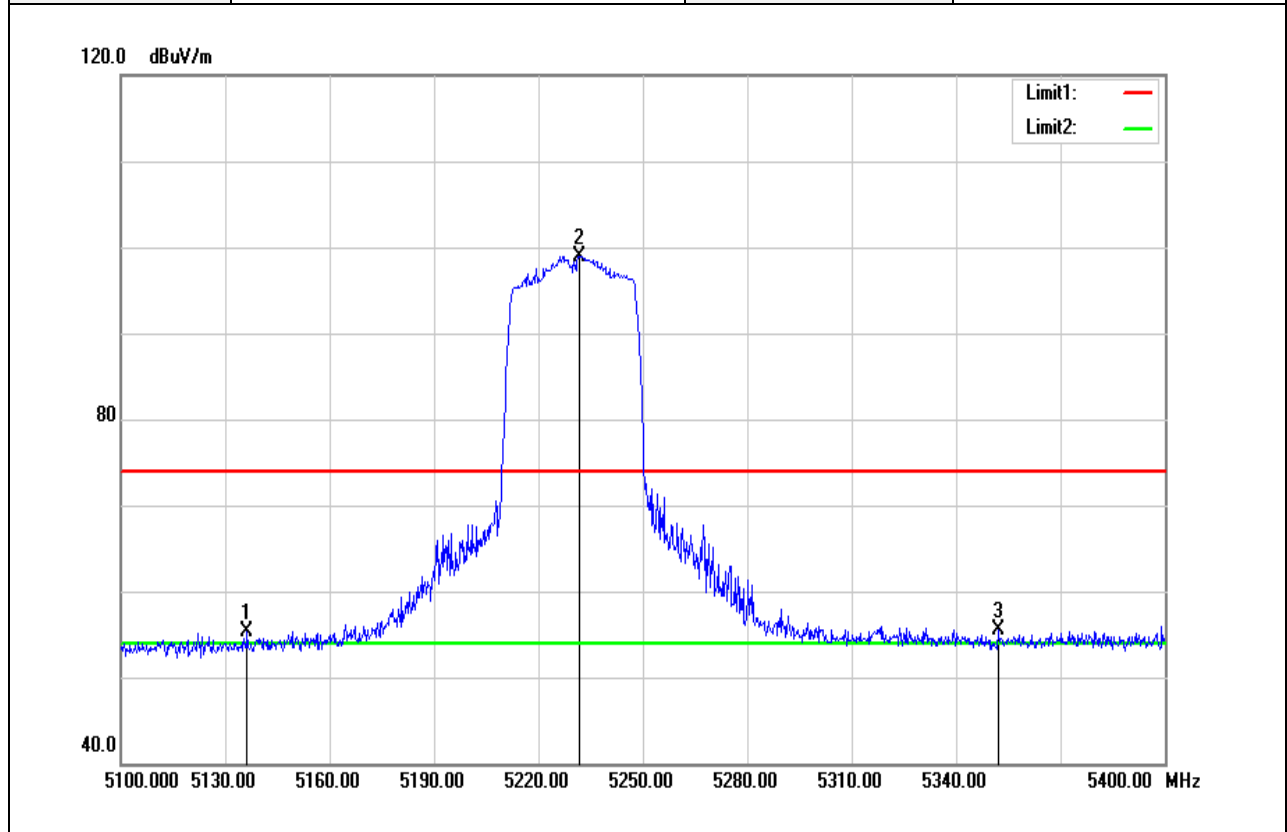

Frequency (MHz)	Reading (dBuV)	Correct Factor (dB/m)	Result (dBuV/m)	Limit (dBuV/m)	Margin (dB)	Remark
5136.300	50.36	4.95	55.31	74.00	-18.69	peak
5231.700	93.71	5.23	98.94	-	-	peak
5352.000	50.15	5.36	55.51	74.00	-18.49	peak

Test Mode	IEEE 802.11n HT40 / 5230MHZ	Temp/Hum	23.2(°C)/ 52%RH
Test Item	Band Edge	Test Date	February 15, 2019
Polarize	Vertical	Test Engineer	Jerry Chuang
Detector	Average		

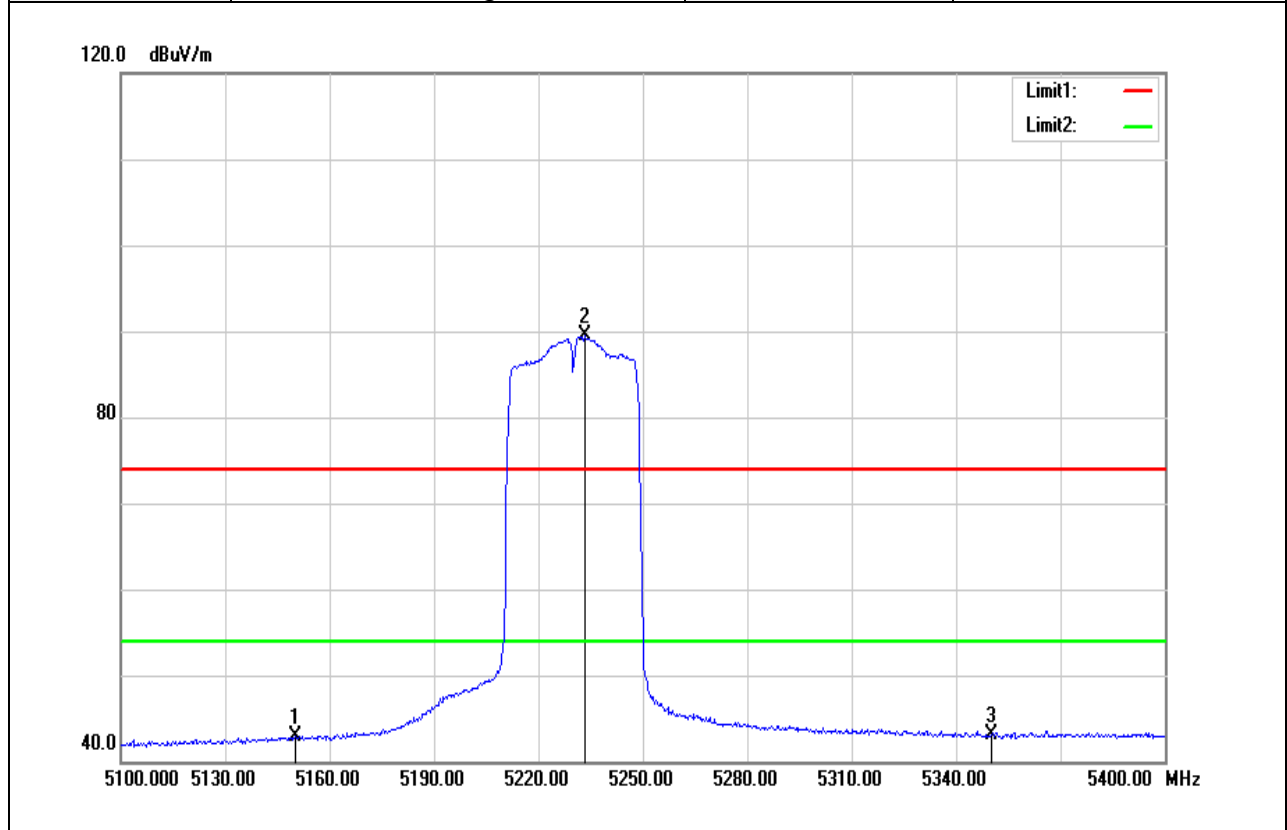

Frequency (MHz)	Reading (dBuV)	Correct Factor (dB/m)	Result (dBuV/m)	Limit (dBuV/m)	Margin (dB)	Remark
5150.000	37.83	5.00	42.83	54.00	-11.17	AVG
5233.200	84.33	5.24	89.57	-	-	AVG
5350.000	37.70	5.36	43.06	54.00	-10.94	AVG

Test Mode	I EEE 802.11ac VHT80 / 5210MHZ	Temp/Hum	23.2(°C)/ 52%RH
Test Item	Band Edge	Test Date	February 15, 2019
Polarize	Vertical	Test Engineer	Jerry Chuang
Detector	Peak		

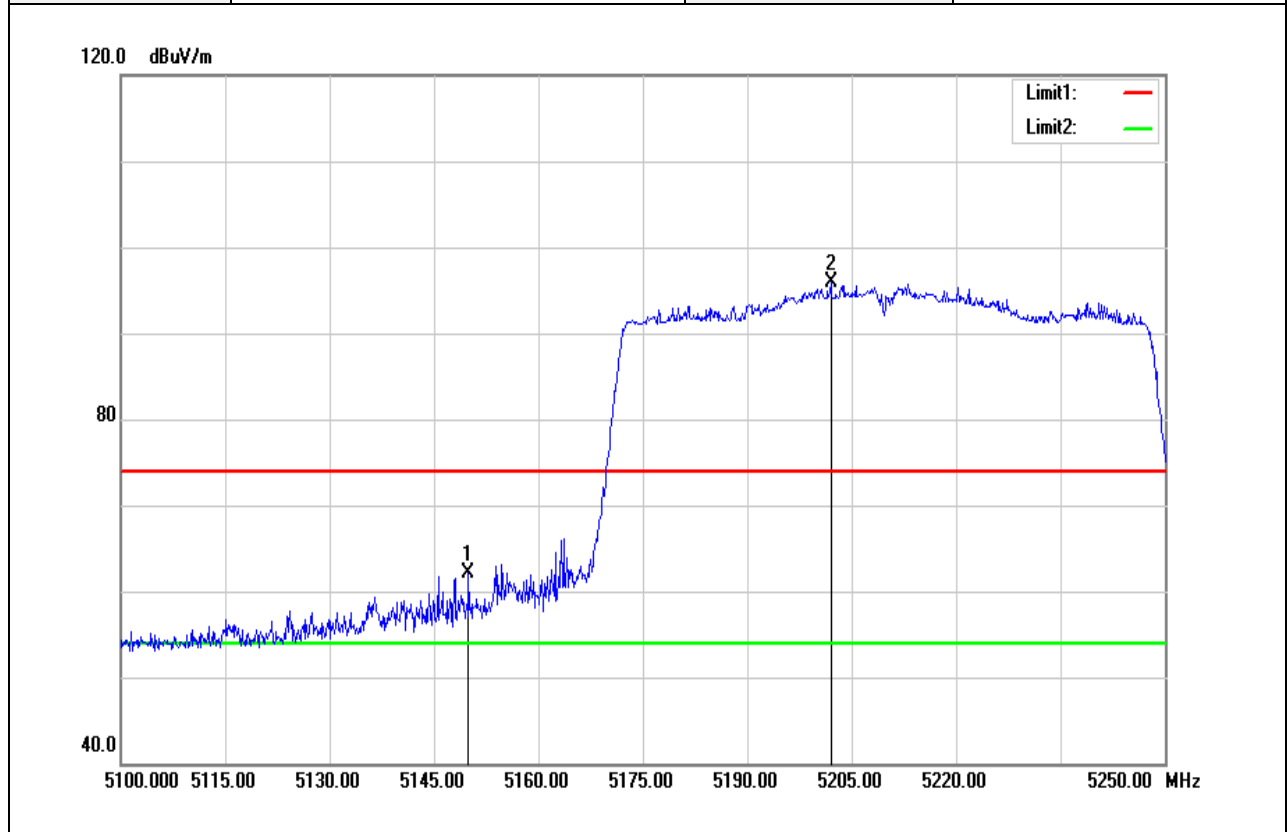

Frequency (MHz)	Reading (dBuV)	Correct Factor (dB/m)	Result (dBuV/m)	Limit (dBuV/m)	Margin (dB)	Remark
5149.950	57.07	5.00	62.07	74.00	-11.93	peak
5202.000	90.74	5.21	95.95	-	-	peak

Test Mode	I EEE 802.11ac VHT80 / 5210MHZ	Temp/Hum	23.2(°C)/ 52%RH
Test Item	Band Edge	Test Date	February 15, 2019
Polarize	Vertical	Test Engineer	Jerry Chuang
Detector	Average		

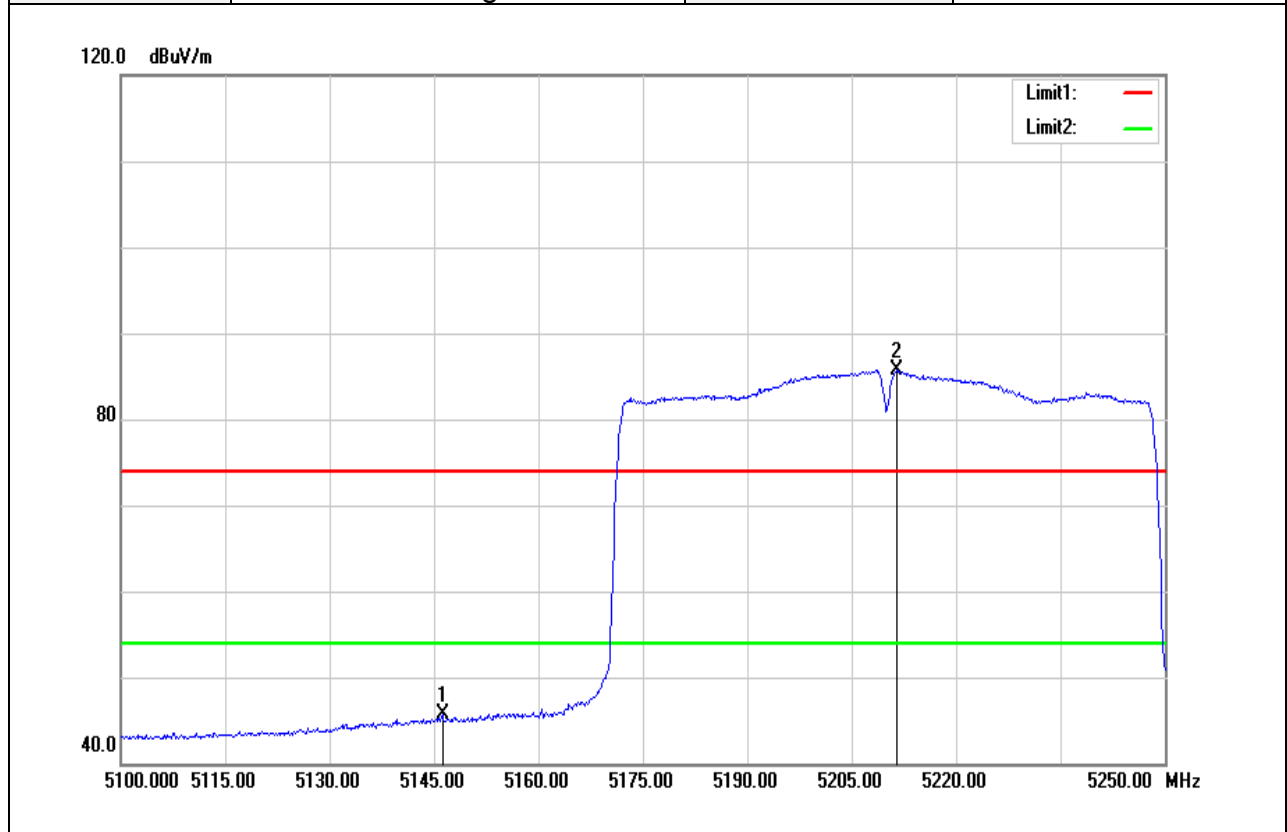

Frequency (MHz)	Reading (dBuV)	Correct Factor (dB/m)	Result (dBuV/m)	Limit (dBuV/m)	Margin (dB)	Remark
5146.200	40.64	4.98	45.62	54.00	-8.38	AVG
5211.450	80.56	5.21	85.77	-	-	AVG

Band Edge Test Data for UNII-2a

Test Mode	IEEE 802.11a / 5260 MHz	Temp/Hum	22.3(°C)/ 51%RH
Test Item	Band Edge	Test Date	February 12, 2019
Polarize	Vertical	Test Engineer	Jerry Chuang
Detector	Peak		

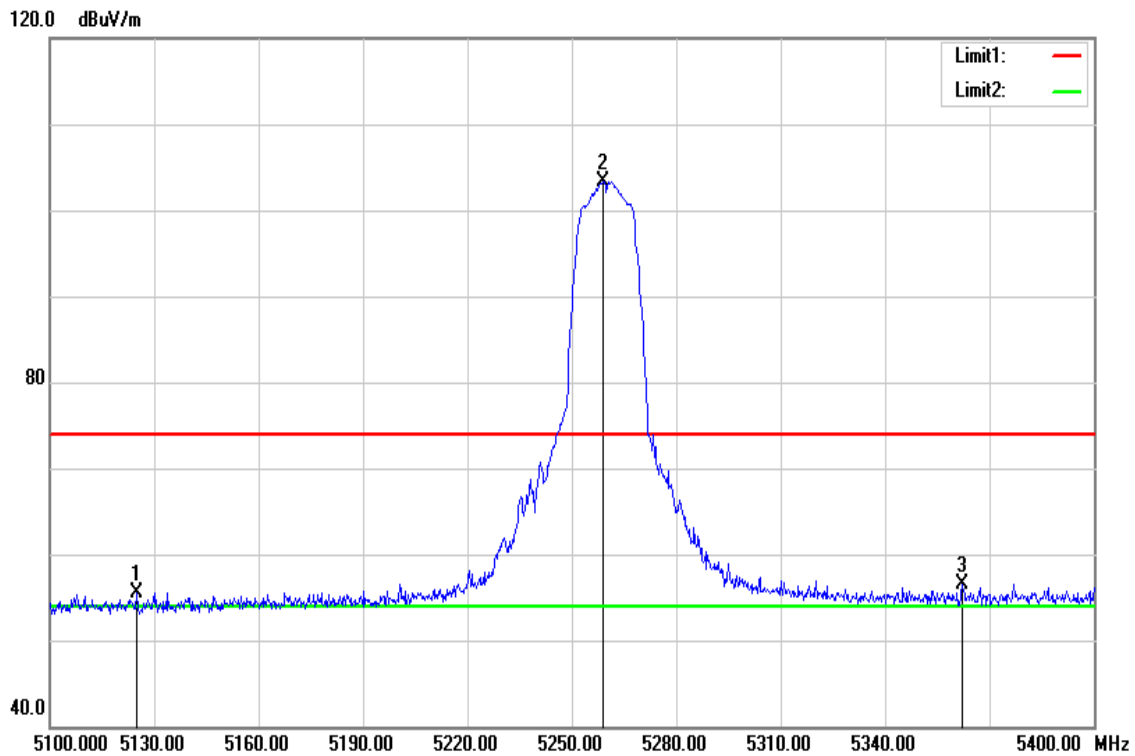

Frequency (MHz)	Reading (dBuV)	Correct Factor (dB/m)	Result (dBuV/m)	Limit (dBuV/m)	Margin (dB)	Remark
5124.900	50.68	4.90	55.58	74.00	-18.42	peak
5259.000	98.06	5.26	103.32	-	-	peak
5362.200	51.18	5.37	56.55	74.00	-17.45	peak

Report No.: T181222W01-RP4

Test Mode	IEEE 802.11a / 5260MHz	Temp/Hum	22.3(°C)/ 51%RH
Test Item	Band Edge	Test Date	February 12, 2019
Polarize	Vertical	Test Engineer	Jerry Chuang
Detector	Average		

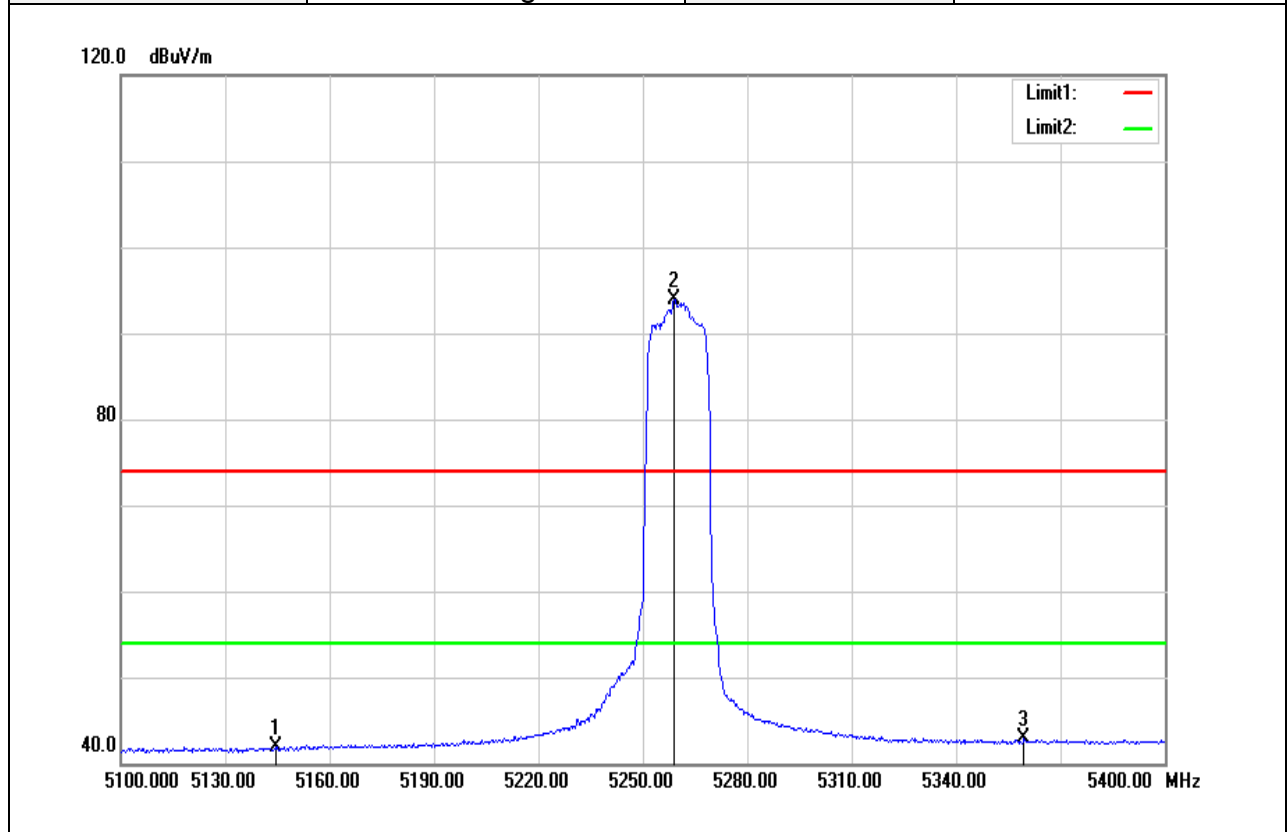

Frequency (MHz)	Reading (dBuV)	Correct Factor (dB/m)	Result (dBuV/m)	Limit (dBuV/m)	Margin (dB)	Remark
5144.700	36.92	4.98	41.90	54.00	-12.10	AVG
5259.000	88.66	5.26	93.92	-	-	AVG
5359.500	37.49	5.37	42.86	54.00	-11.14	AVG

Test Mode	IEEE 802.11a / 5320MHz	Temp/Hum	22.3(°C)/ 51%RH
Test Item	Band Edge	Test Date	February 12, 2019
Polarize	Vertical	Test Engineer	Jerry Chuang
Detector	Peak		

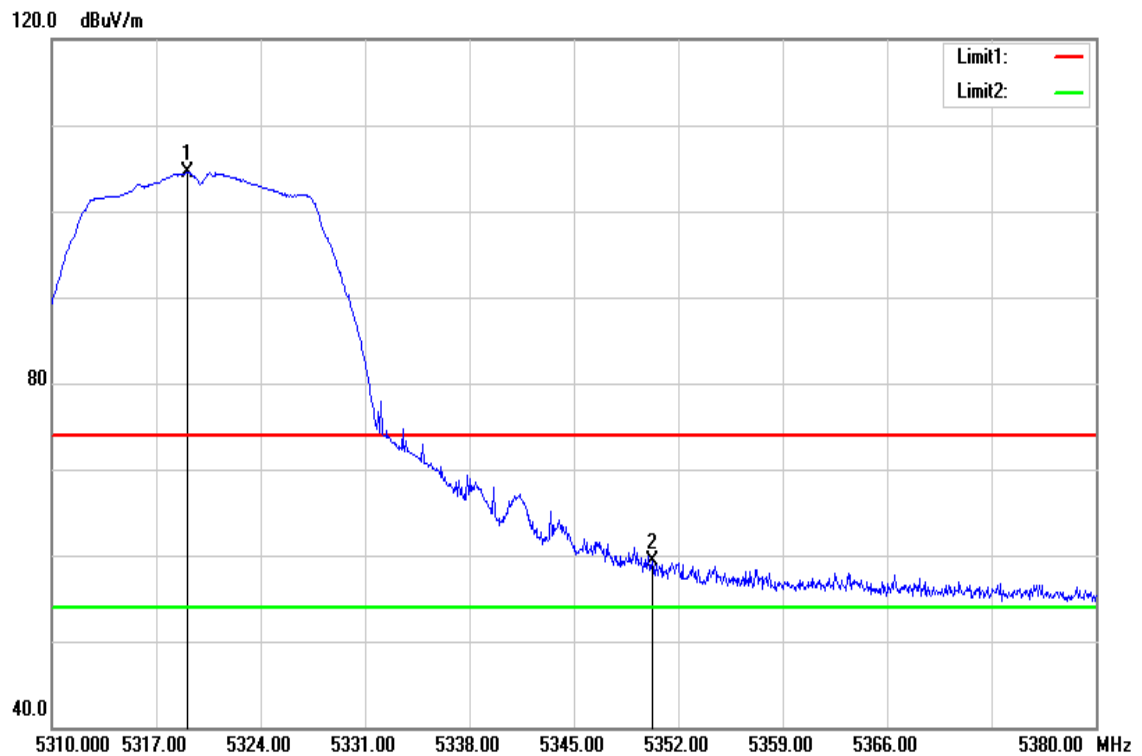

Frequency (MHz)	Reading (dBuV)	Correct Factor (dB/m)	Result (dBuV/m)	Limit (dBuV/m)	Margin (dB)	Remark
5319.100	99.19	5.32	104.51	-	-	peak
5350.250	53.84	5.36	59.20	74.00	-14.80	peak

Test Mode	IEEE 802.11a / 5320MHz	Temp/Hum	22.3(°C)/ 51%RH
Test Item	Band Edge	Test Date	February 12, 2019
Polarize	Vertical	Test Engineer	Jerry Chuang
Detector	Average		

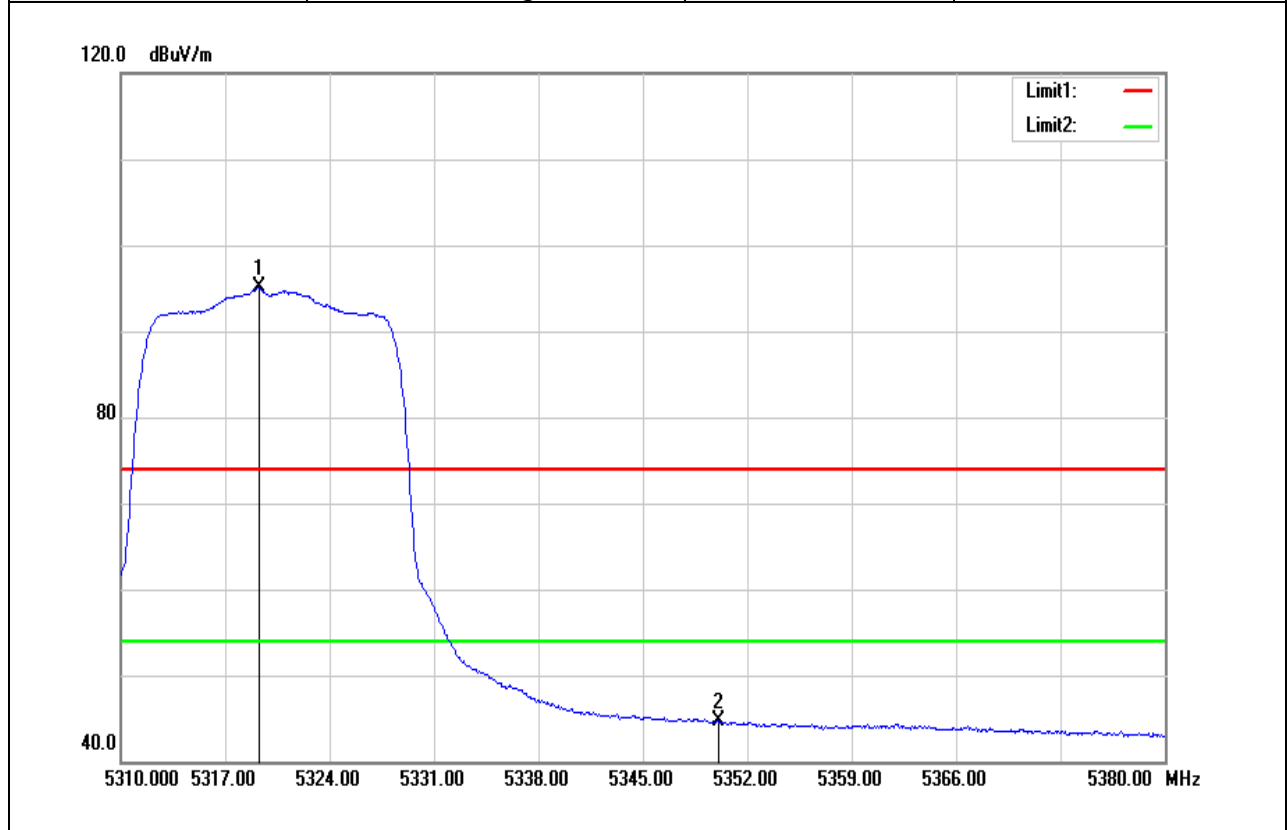

Frequency (MHz)	Reading (dBuV)	Correct Factor (dB/m)	Result (dBuV/m)	Limit (dBuV/m)	Margin (dB)	Remark
5319.240	89.70	5.32	95.02	-	-	AVG
5350.040	39.34	5.36	44.70	54.00	-9.30	AVG

Test Mode	IEEE 802.11n HT20 / 5260MHz	Temp/Hum	23.2(°C)/ 52%RH
Test Item	Band Edge	Test Date	February 15, 2019
Polarize	Vertical	Test Engineer	Jerry Chuang
Detector	Peak		

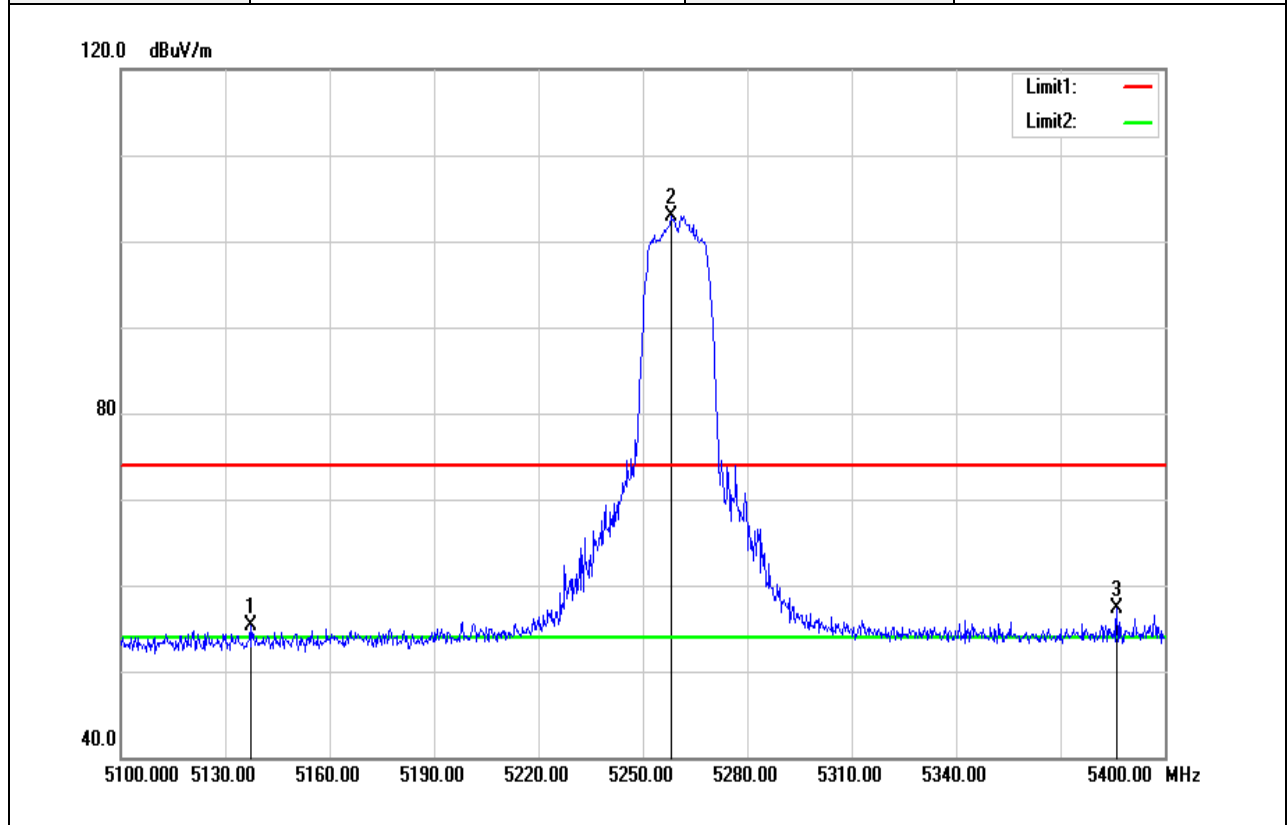

Frequency (MHz)	Reading (dBuV)	Correct Factor (dB/m)	Result (dBuV/m)	Limit (dBuV/m)	Margin (dB)	Remark
5137.200	50.31	4.95	55.26	74.00	-18.74	peak
5258.100	97.73	5.26	102.99	-	-	peak
5386.200	51.88	5.39	57.27	74.00	-16.73	peak

Report No.: T181222W01-RP4

Test Mode	IEEE 802.11n HT20 / 5260MHz	Temp/Hum	23.2(°C)/ 52%RH
Test Item	Band Edge	Test Date	February 15, 2019
Polarize	Vertical	Test Engineer	Jerry Chuang
Detector	Average		

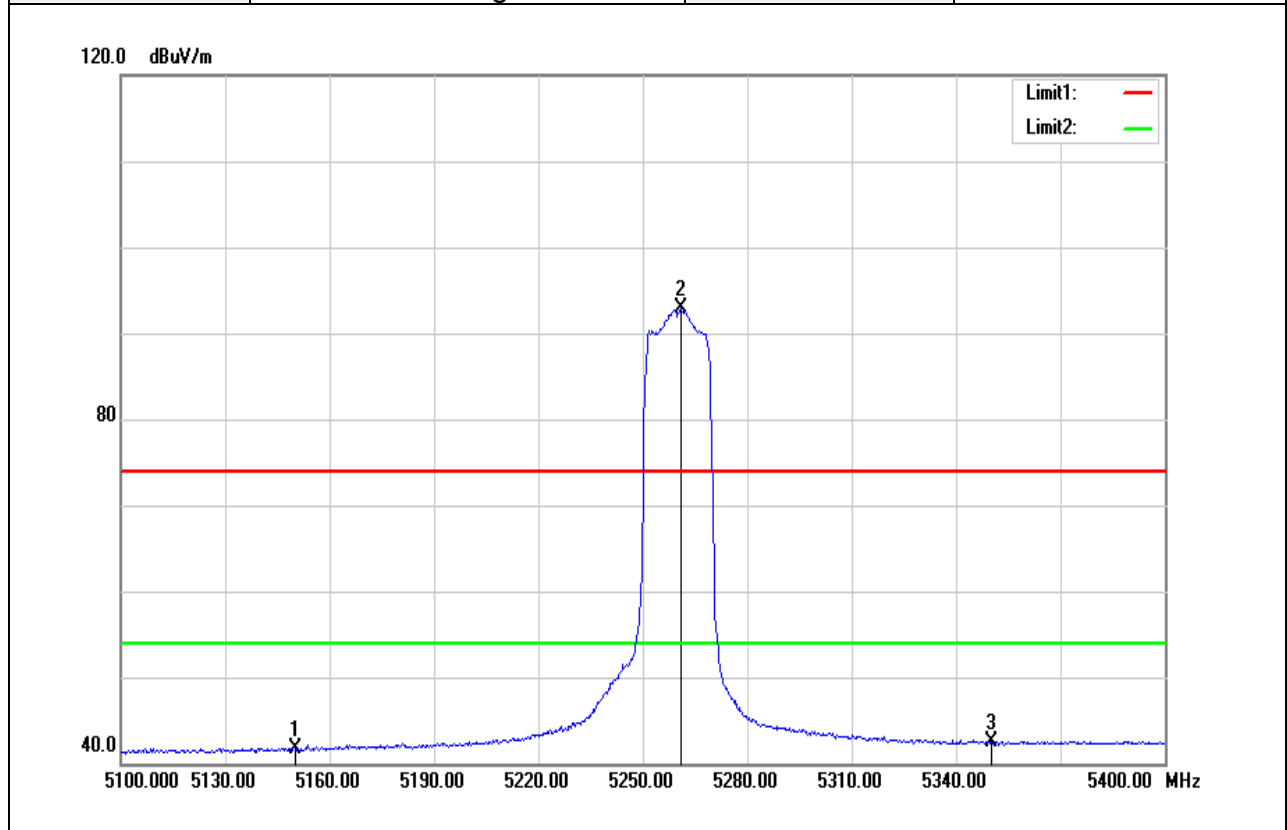

Frequency (MHz)	Reading (dBuV)	Correct Factor (dB/m)	Result (dBuV/m)	Limit (dBuV/m)	Margin (dB)	Remark
5150.000	36.66	5.00	41.66	54.00	-12.34	AVG
5260.800	87.55	5.27	92.82	-	-	AVG
5350.000	37.18	5.36	42.54	54.00	-11.46	AVG

Test Mode	IEEE 802.11n HT20 / 5320MHz	Temp/Hum	23.2(°C)/ 52%RH
Test Item	Band Edge	Test Date	February 15, 2019
Polarize	Vertical	Test Engineer	Jerry Chuang
Detector	Peak		

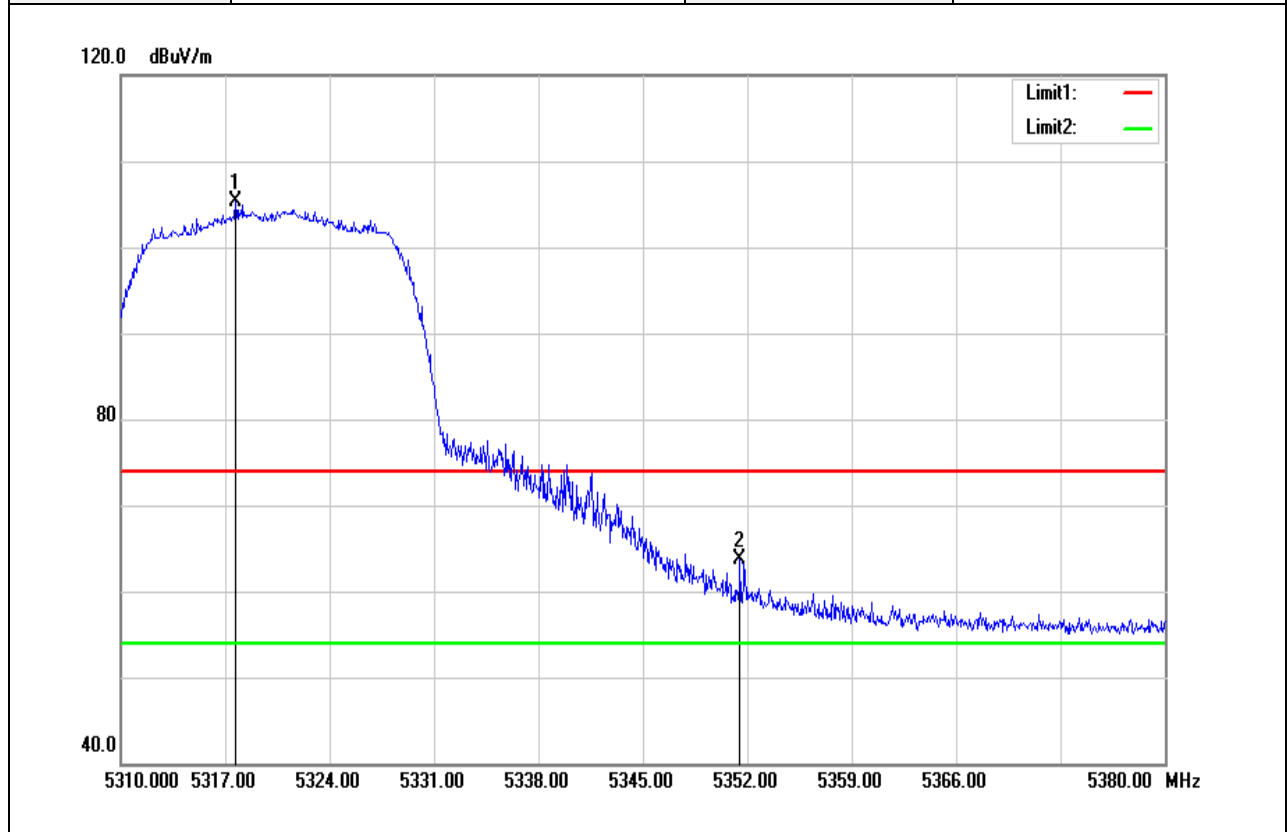

Frequency (MHz)	Reading (dBuV)	Correct Factor (dB/m)	Result (dBuV/m)	Limit (dBuV/m)	Margin (dB)	Remark
5317.700	100.00	5.32	105.32	-	-	peak
5351.510	58.34	5.36	63.70	74.00	-10.30	peak

Test Mode	IEEE 802.11n HT20 / 5320MHz	Temperature	23.2(°C)/ 52%RH
Test Item	Band Edge	Test Date	February 15, 2019
Polarize	Vertical	Test Engineer	Jerry Chuang
Detector	Average		

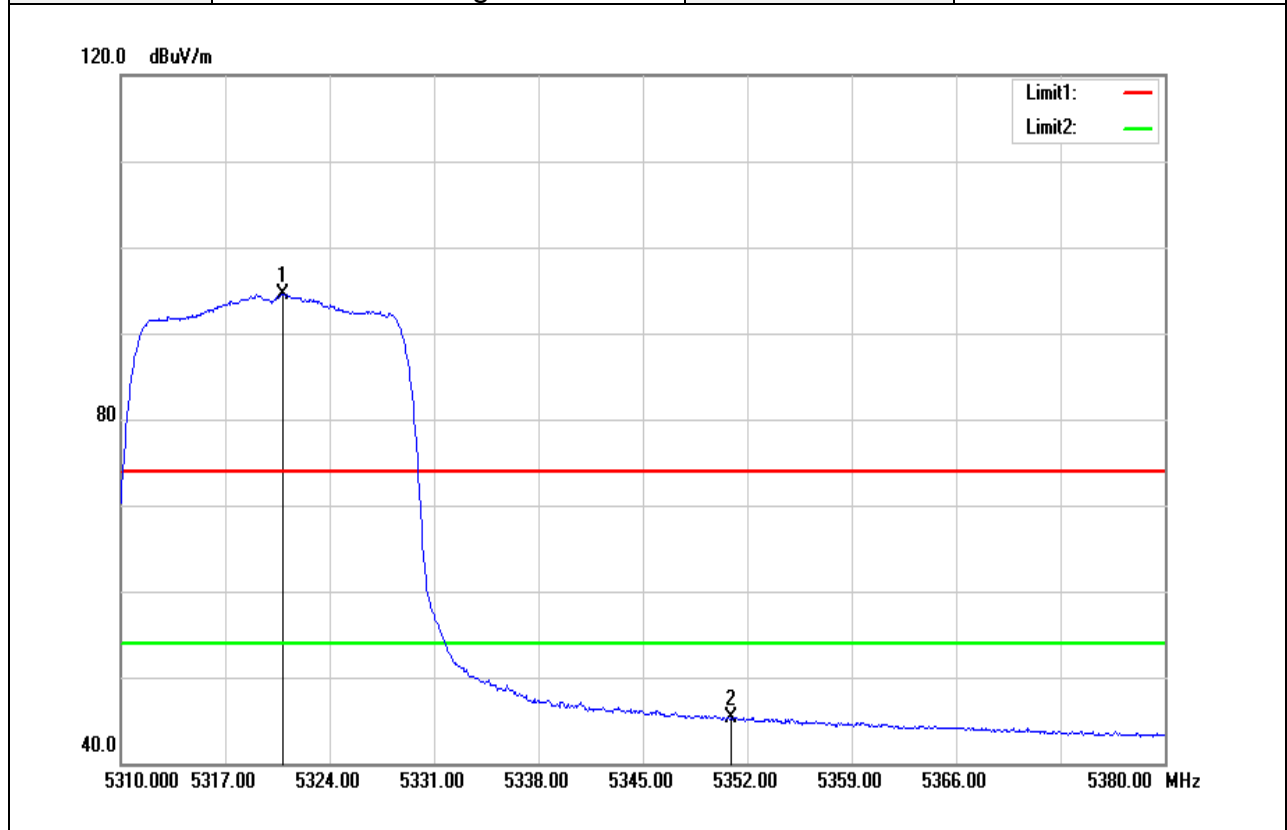

Frequency (MHz)	Reading (dBuV)	Correct Factor (dB/m)	Result (dBuV/m)	Limit (dBuV/m)	Margin (dB)	Remark
5320.850	89.25	5.33	94.58	-	-	AVG
5350.880	40.03	5.36	45.39	54.00	-8.61	AVG

Test Mode	IEEE 802.11n HT40 / 5270MHz	Temp/Hum	23.2(°C)/ 52%RH
Test Item	Band Edge	Test Date	February 15, 2019
Polarize	Vertical	Test Engineer	Jerry Chuang
Detector	Peak		

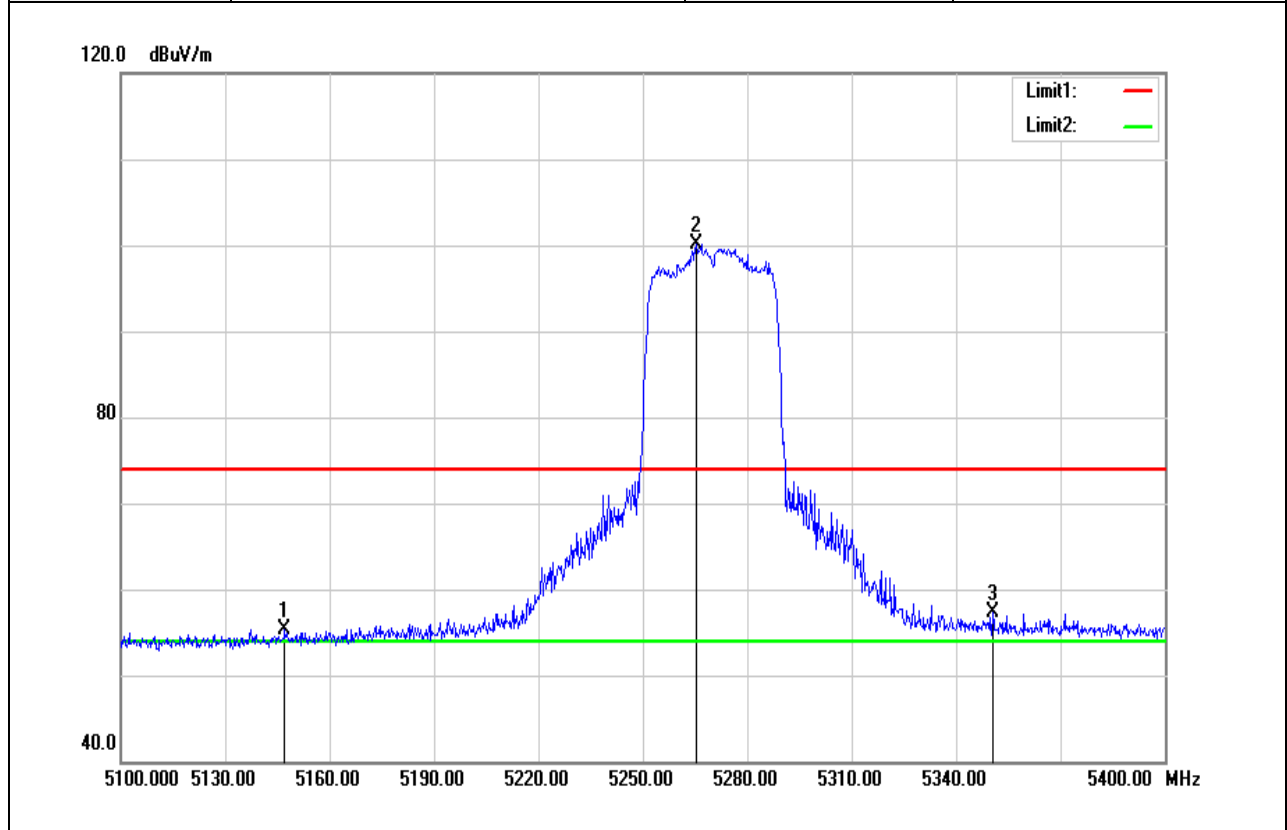

Frequency (MHz)	Reading (dBuV)	Correct Factor (dB/m)	Result (dBuV/m)	Limit (dBuV/m)	Margin (dB)	Remark
5147.100	50.30	4.99	55.29	74.00	-18.71	peak
5265.300	94.76	5.26	100.02	-	-	peak
5350.500	52.03	5.36	57.39	74.00	-16.61	peak

Test Mode	IEEE 802.11n HT40 / 5270MHz	Temperature	23.2(°C)/ 52%RH
Test Item	Band Edge	Test Date	February 15, 2019
Polarize	Vertical	Test Engineer	Jerry Chuang
Detector	Average		

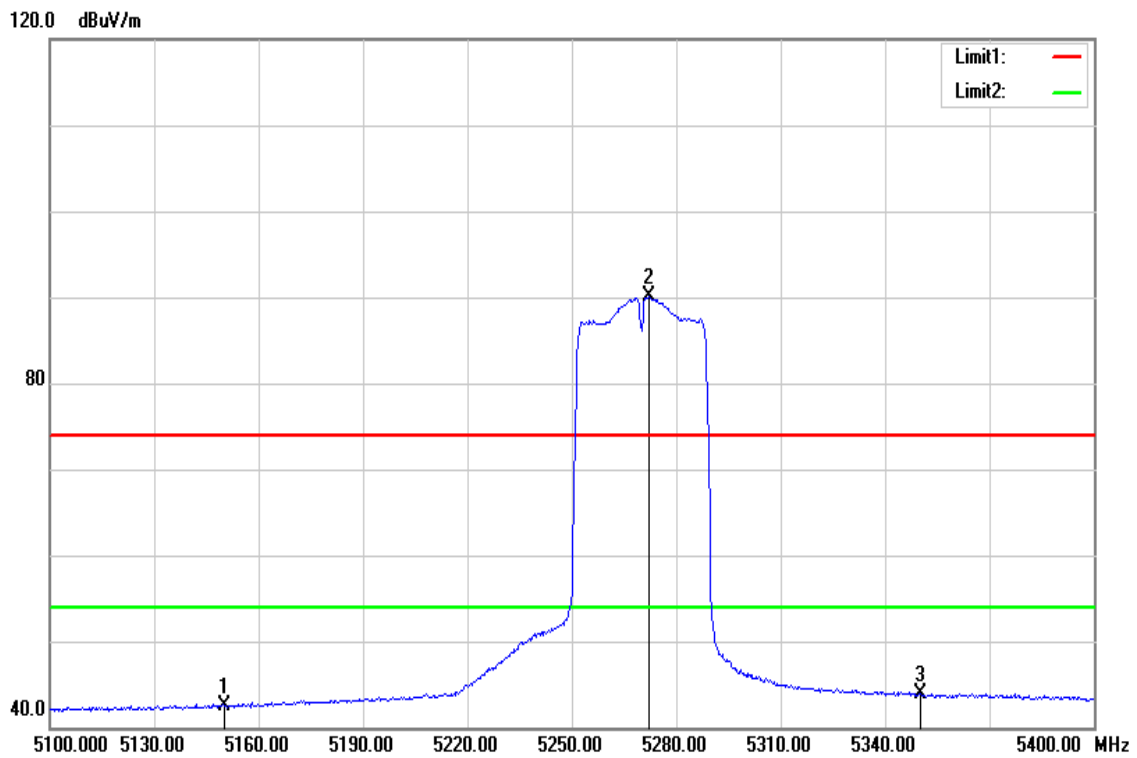

Frequency (MHz)	Reading (dBuV)	Correct Factor (dB/m)	Result (dBuV/m)	Limit (dBuV/m)	Margin (dB)	Remark
5150.000	37.59	5.00	42.59	54.00	-11.41	AVG
5272.200	84.78	5.28	90.06	-	-	AVG
5350.000	38.58	5.36	43.94	54.00	-10.06	AVG

Test Mode	IEEE 802.11n HT40 / 5310MHz	Temp/Hum	23.2(°C)/ 52%RH
Test Item	Band Edge	Test Date	February 15, 2019
Polarize	Vertical	Test Engineer	Jerry Chuang
Detector	Peak		

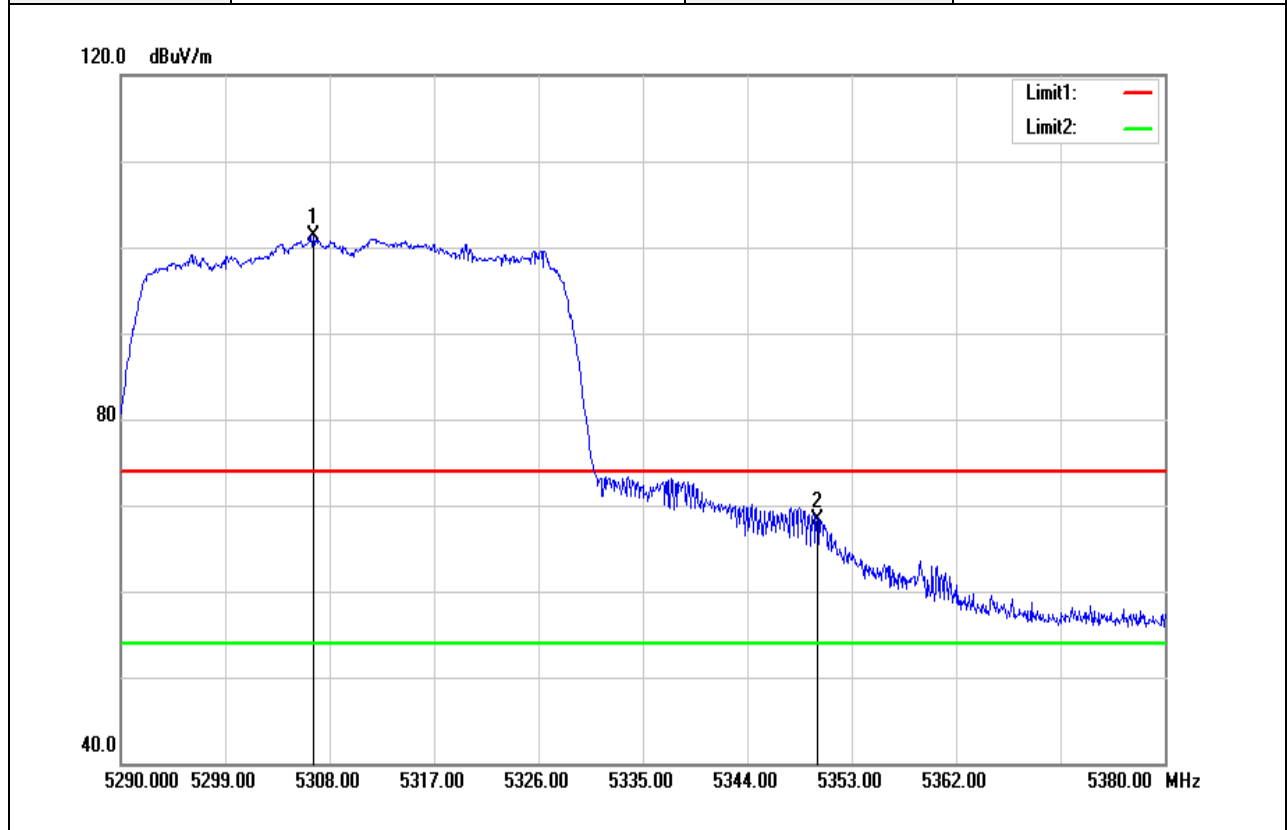

Frequency (MHz)	Reading (dBuV)	Correct Factor (dB/m)	Result (dBuV/m)	Limit (dBuV/m)	Margin (dB)	Remark
5306.560	95.98	5.31	101.29	-	-	peak
5350.000	63.03	5.36	68.39	74.00	-5.61	peak

Test Mode	IEEE 802.11n HT40 / 5310MHz	Temperature	23.2(°C)/ 52%RH
Test Item	Band Edge	Test Date	February 15, 2019
Polarize	Vertical	Test Engineer	Jerry Chuang
Detector	Average		

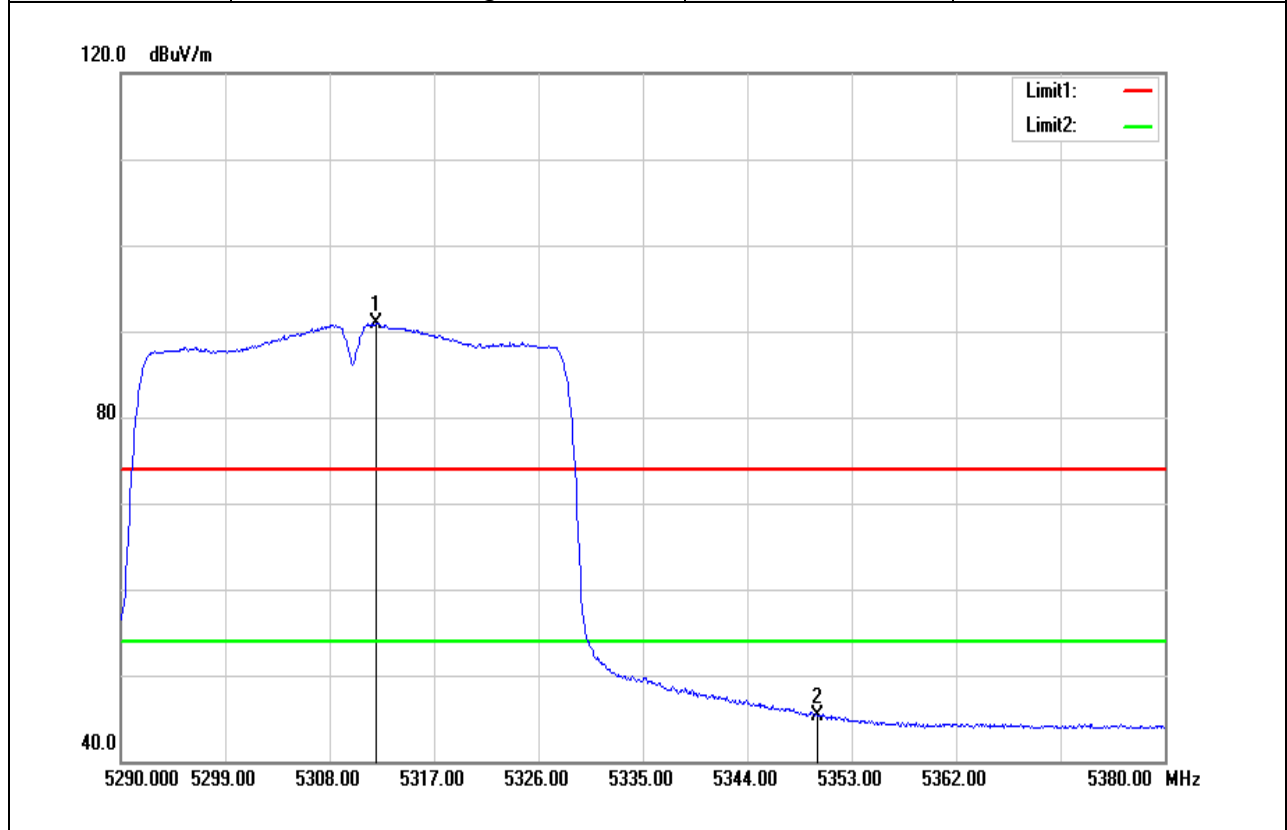

Frequency (MHz)	Reading (dBuV)	Correct Factor (dB/m)	Result (dBuV/m)	Limit (dBuV/m)	Margin (dB)	Remark
5312.050	85.63	5.32	90.95	-	-	AVG
5350.000	39.92	5.36	45.28	54.00	-8.72	AVG

Test Mode	IEEE 802.11ac VHT80 / 5290MHz	Temp/Hum	23.2(°C)/ 52%RH
Test Item	Band Edge	Test Date	February 15, 2019
Polarize	Vertical	Test Engineer	Jerry Chuang
Detector	Peak		

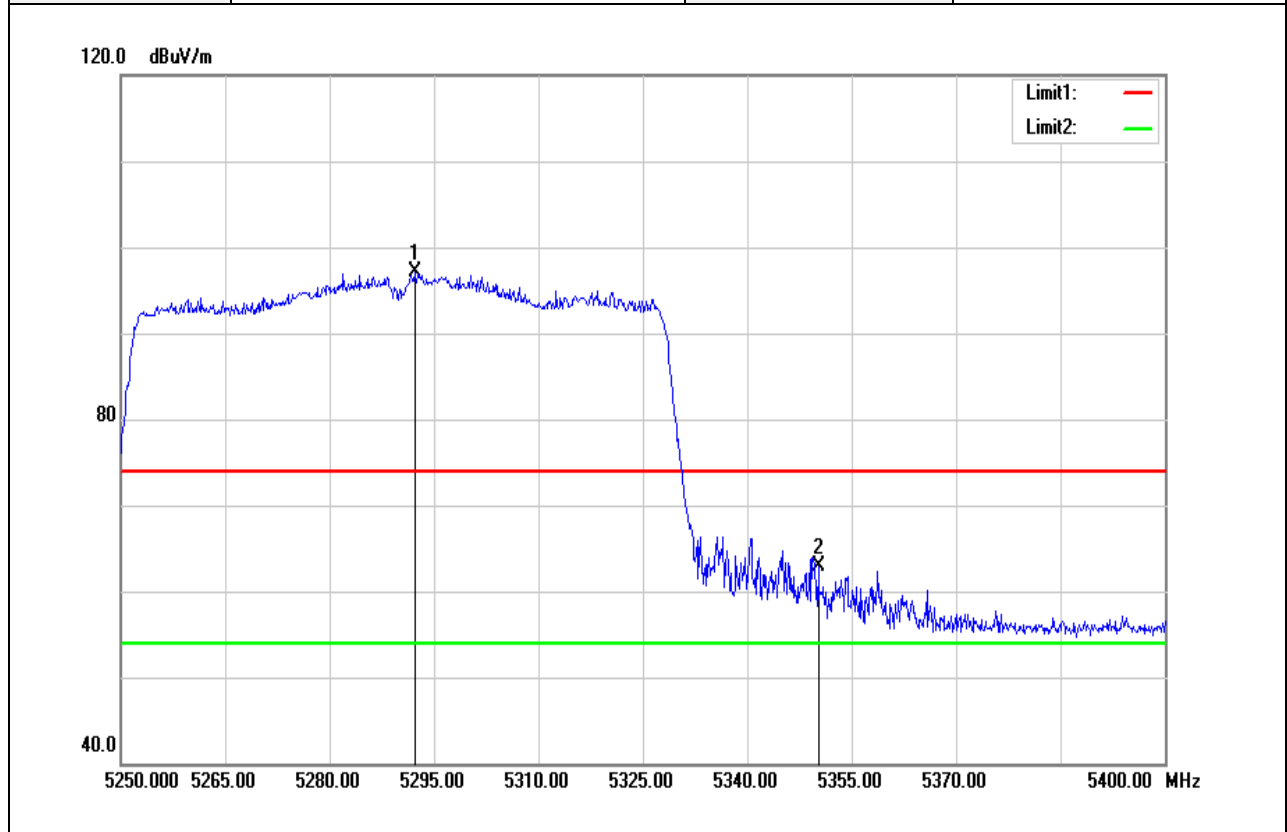

Frequency (MHz)	Reading (dBuV)	Correct Factor (dB/m)	Result (dBuV/m)	Limit (dBuV/m)	Margin (dB)	Remark
5292.300	91.73	5.30	97.03	-	-	peak
5350.200	57.54	5.36	62.90	74.00	-11.10	peak

Test Mode	IEEE 802.11ac VHT80 / 5290MHz	Temperature	23.2(°C)/ 52%RH
Test Item	Band Edge	Test Date	February 15, 2019
Polarize	Vertical	Test Engineer	Jerry Chuang
Detector	Average		

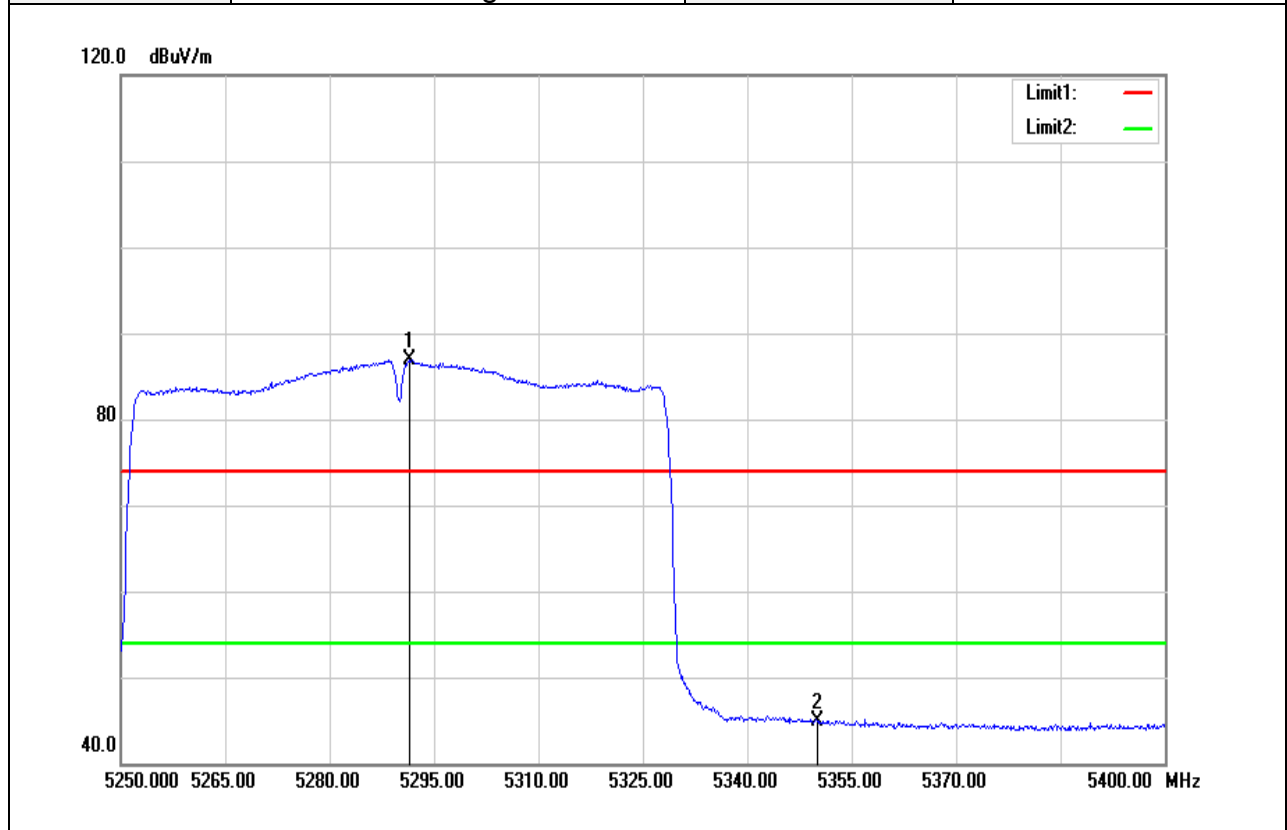

Frequency (MHz)	Reading (dBuV)	Correct Factor (dB/m)	Result (dBuV/m)	Limit (dBuV/m)	Margin (dB)	Remark
5291.400	81.61	5.30	86.91	-	-	AVG
5350.000	39.45	5.36	44.81	54.00	-9.19	AVG

Report No.: T181222W01-RP4

Band Edge Test Data for UNII-2c

Test Mode	IEEE 802.11a / 5500MHz	Temp/Hum	23.2(°C)/ 52%RH
Test Item	Band Edge	Test Date	February 15, 2019
Polarize	Vertical	Test Engineer	Jerry Chuang
Detector	Peak		

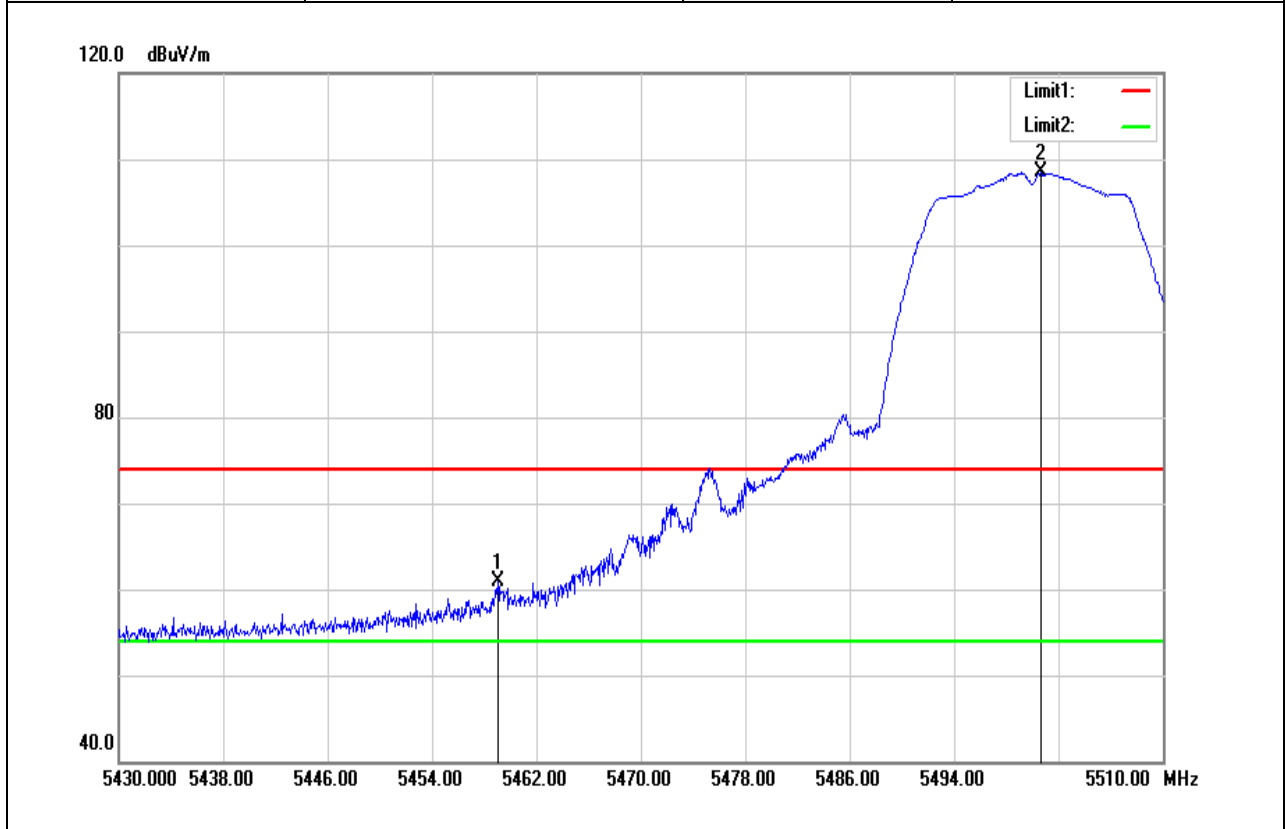

Frequency (MHz)	Reading (dBuV)	Correct Factor (dB/m)	Result (dBuV/m)	Limit (dBuV/m)	Margin (dB)	Remark
5459.040	55.28	5.67	60.95	74.00	-13.05	peak
5500.640	102.56	5.86	108.42	-	-	peak

Test Mode	IEEE 802.11a / 5500MHz	Temperature	23.2(°C)/ 52%RH
Test Item	Band Edge	Test Date	February 15, 2019
Polarize	Vertical	Test Engineer	Jerry Chuang
Detector	Average		

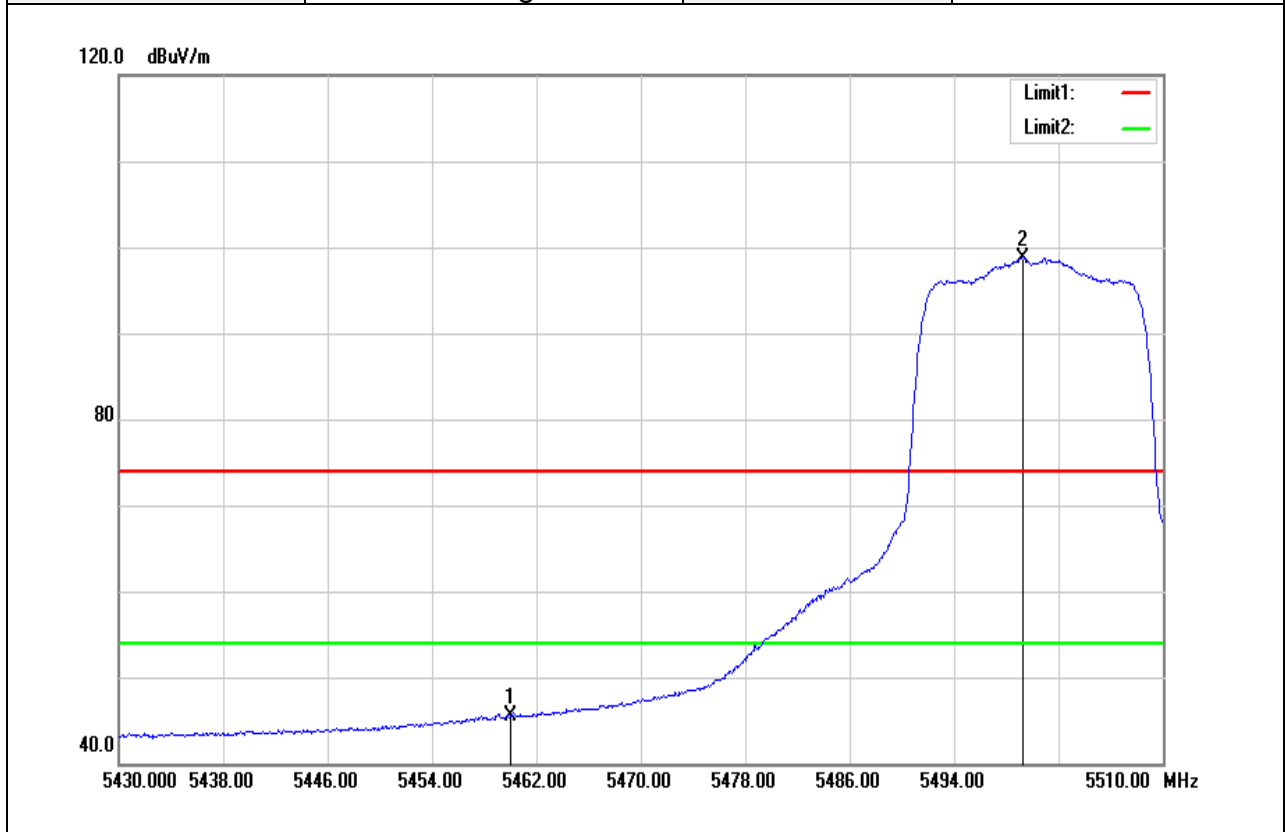

Frequency (MHz)	Reading (dBuV)	Correct Factor (dB/m)	Result (dBuV/m)	Limit (dBuV/m)	Margin (dB)	Remark
5460.000	39.88	5.68	45.56	54.00	-8.44	AVG
5499.280	92.94	5.86	98.80	-	-	AVG

Test Mode	IEEE 802.11a / 5700 MHz	Temp/Hum	22.5(°C)/ 50%RH
Test Item	Band Edge	Test Date	January 30, 2019
Polarize	Vertical	Test Engineer	Jerry Chuang
Detector	Peak		

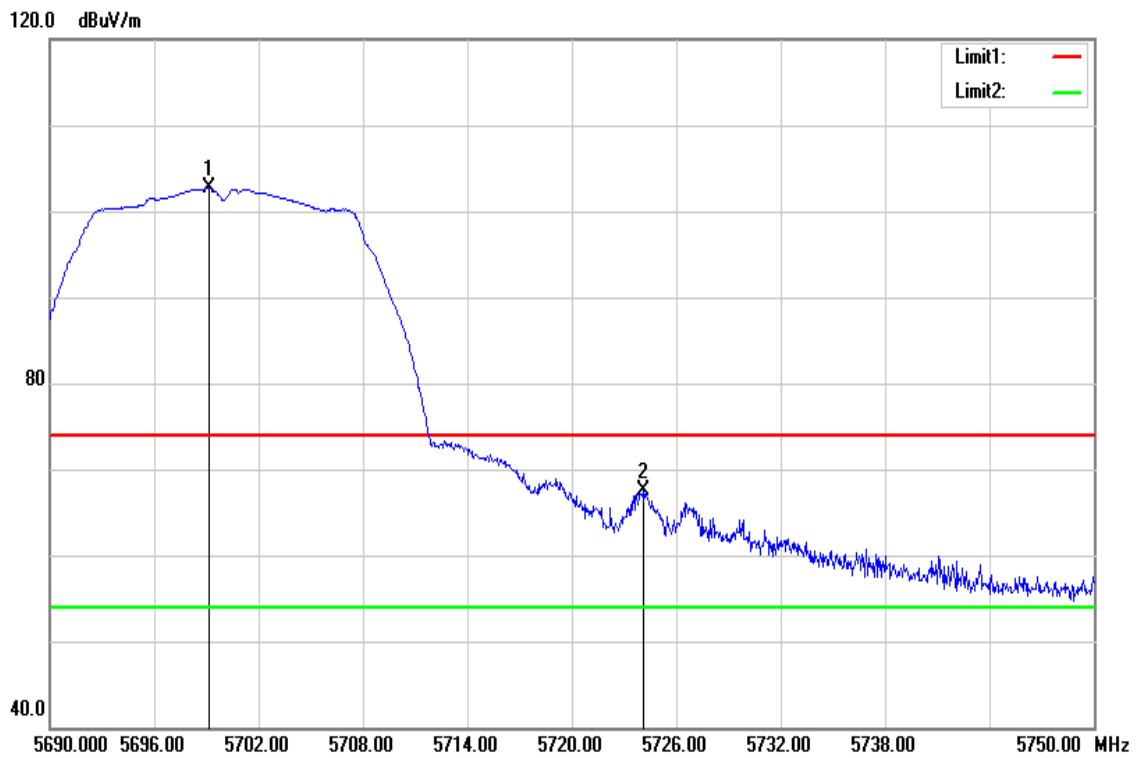

Frequency (MHz)	Reading (dBuV)	Correct Factor (dB/m)	Result (dBuV/m)	Limit (dBuV/m)	Margin (dB)	Remark
5699.120	96.05	6.65	102.70	-	-	peak
5724.080	60.77	6.77	67.54	74.00	-6.46	peak

Test Mode	IEEE 802.11a / 5700 MHz	Temperature	22.5(°C)/ 50%RH
Test Item	Band Edge	Test Date	January 30, 2019
Polarize	Vertical	Test Engineer	Jerry Chuang
Detector	Average		

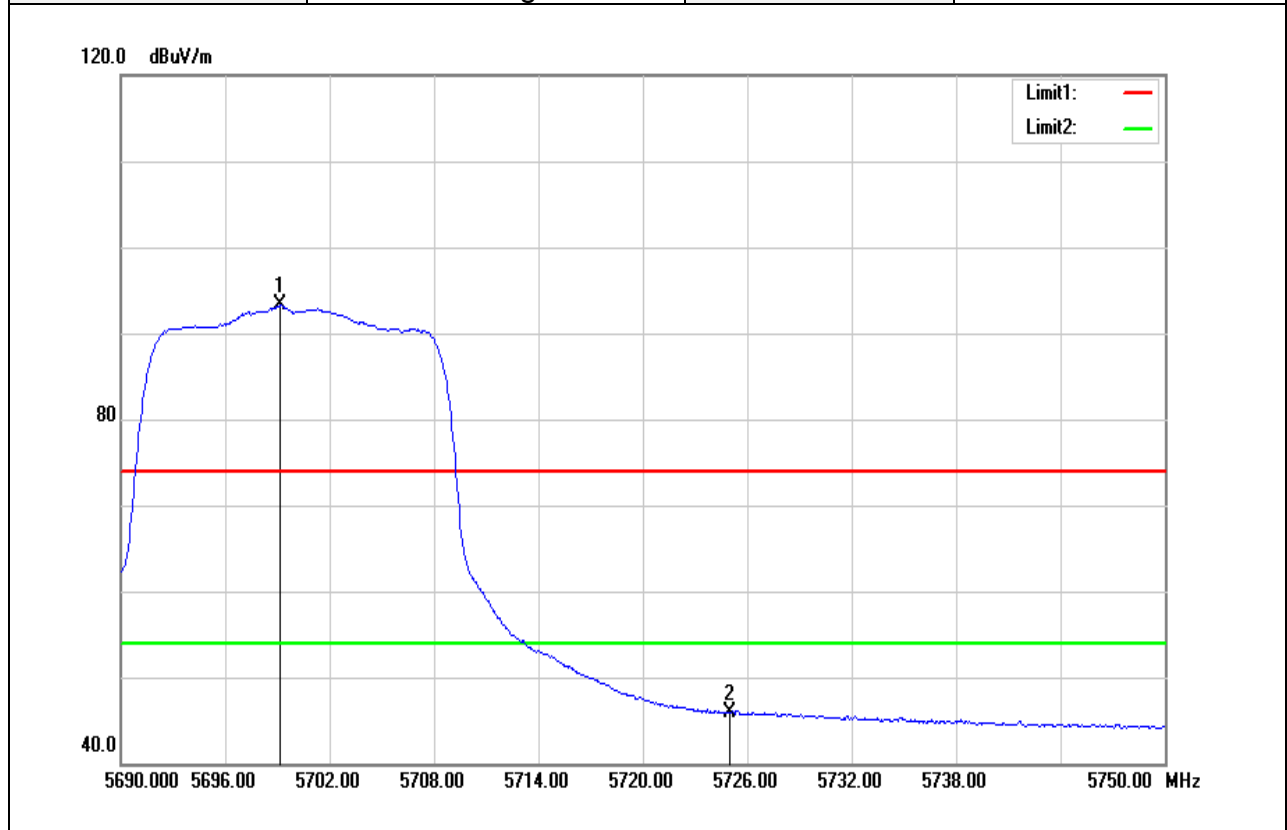

Frequency (MHz)	Reading (dBuV)	Correct Factor (dB/m)	Result (dBuV/m)	Limit (dBuV/m)	Margin (dB)	Remark
5699.180	86.58	6.65	93.23	-	-	AVG
5725.000	39.09	6.77	45.86	54.00	-8.14	AVG

Test Mode	IEEE 802.11n HT20 / 5500MHz	Temp/Hum	23.2(°C)/ 52%RH
Test Item	Band Edge	Test Date	February 15, 2019
Polarize	Vertical	Test Engineer	Jerry Chuang
Detector	Peak		

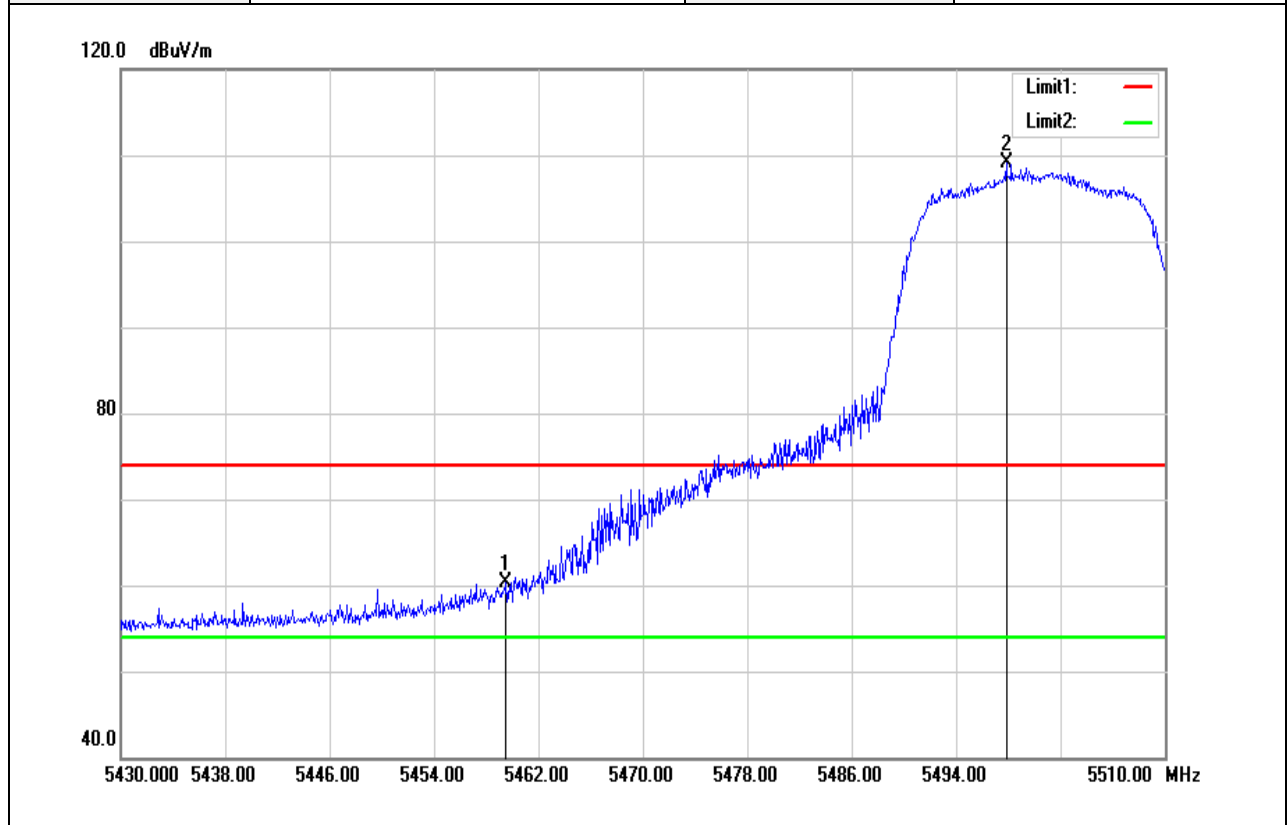

Frequency (MHz)	Reading (dBuV)	Correct Factor (dB/m)	Result (dBuV/m)	Limit (dBuV/m)	Margin (dB)	Remark
5459.520	54.56	5.68	60.24	74.00	-13.76	peak
5497.840	103.29	5.85	109.14	-	-	peak

Test Mode	IEEE 802.11n HT20 / 5500MHz	Temperature	23.2(°C)/ 52%RH
Test Item	Band Edge	Test Date	February 15, 2019
Polarize	Vertical	Test Engineer	Jerry Chuang
Detector	Average		

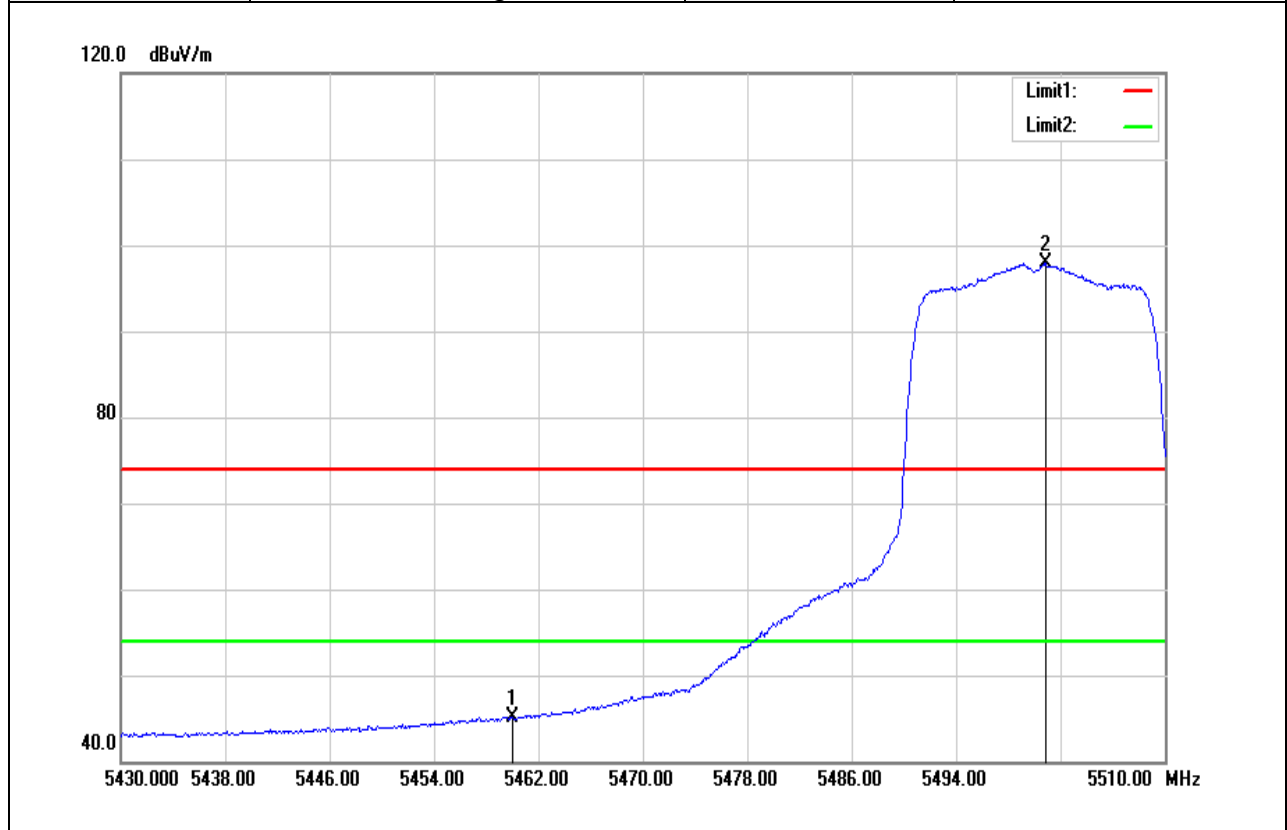

Frequency (MHz)	Reading (dBuV)	Correct Factor (dB/m)	Result (dBuV/m)	Limit (dBuV/m)	Margin (dB)	Remark
5460.000	39.44	5.68	45.12	54.00	-8.88	AVG
5500.880	92.07	5.86	97.93	-	-	AVG

Test Mode	IEEE 802.11n HT20 / 5700 MHz	Temp/Hum	23.2(°C)/ 52%RH
Test Item	Band Edge	Test Date	February 15, 2019
Polarize	Vertical	Test Engineer	Jerry Chuang
Detector	Peak		

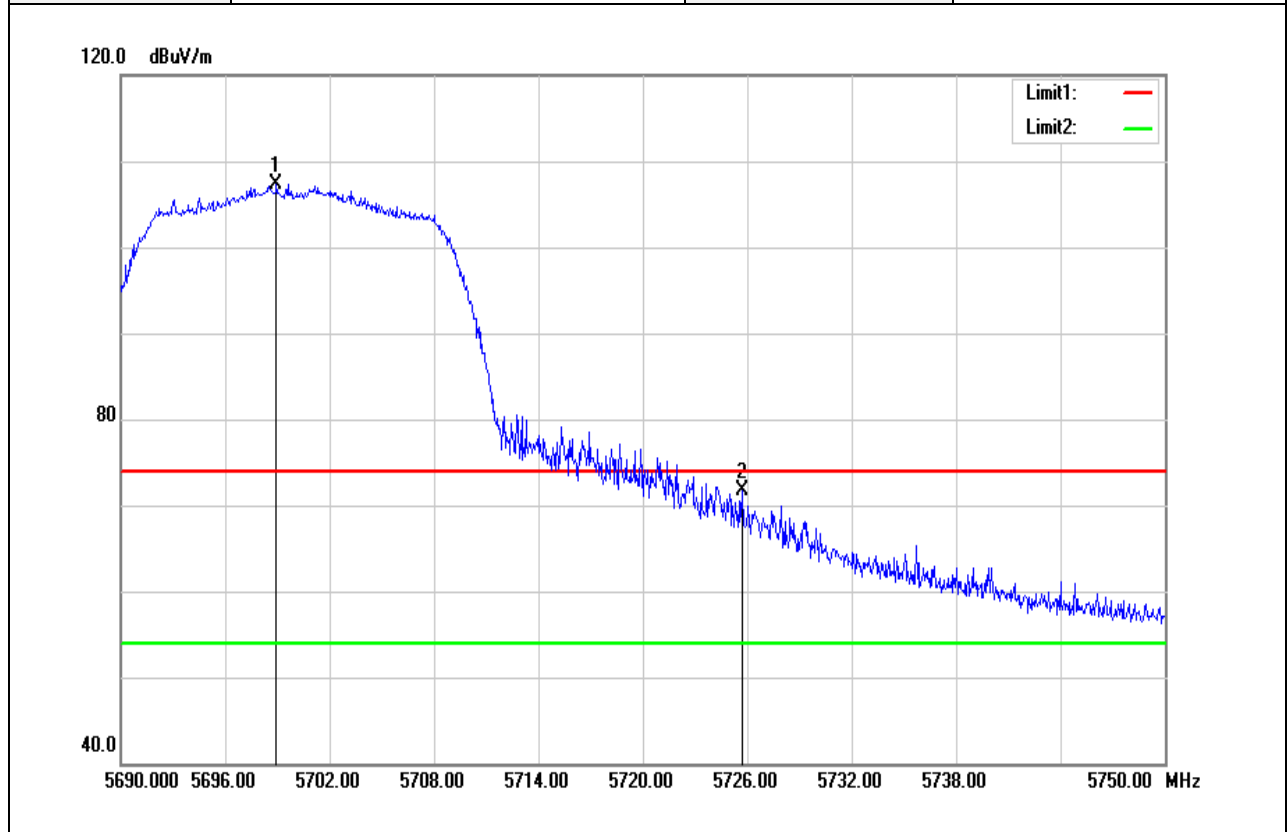

Frequency (MHz)	Reading (dBuV)	Correct Factor (dB/m)	Result (dBuV/m)	Limit (dBuV/m)	Margin (dB)	Remark
5698.940	100.75	6.65	107.40	-	-	peak
5725.700	64.99	6.77	71.76	74.00	-2.24	peak

Report No.: T181222W01-RP4

Test Mode	IEEE 802.11n HT20 / 5700 MHz	Temperature	23.2(°C)/ 52%RH
Test Item	Band Edge	Test Date	February 15, 2019
Polarize	Vertical	Test Engineer	Jerry Chuang
Detector	Average		

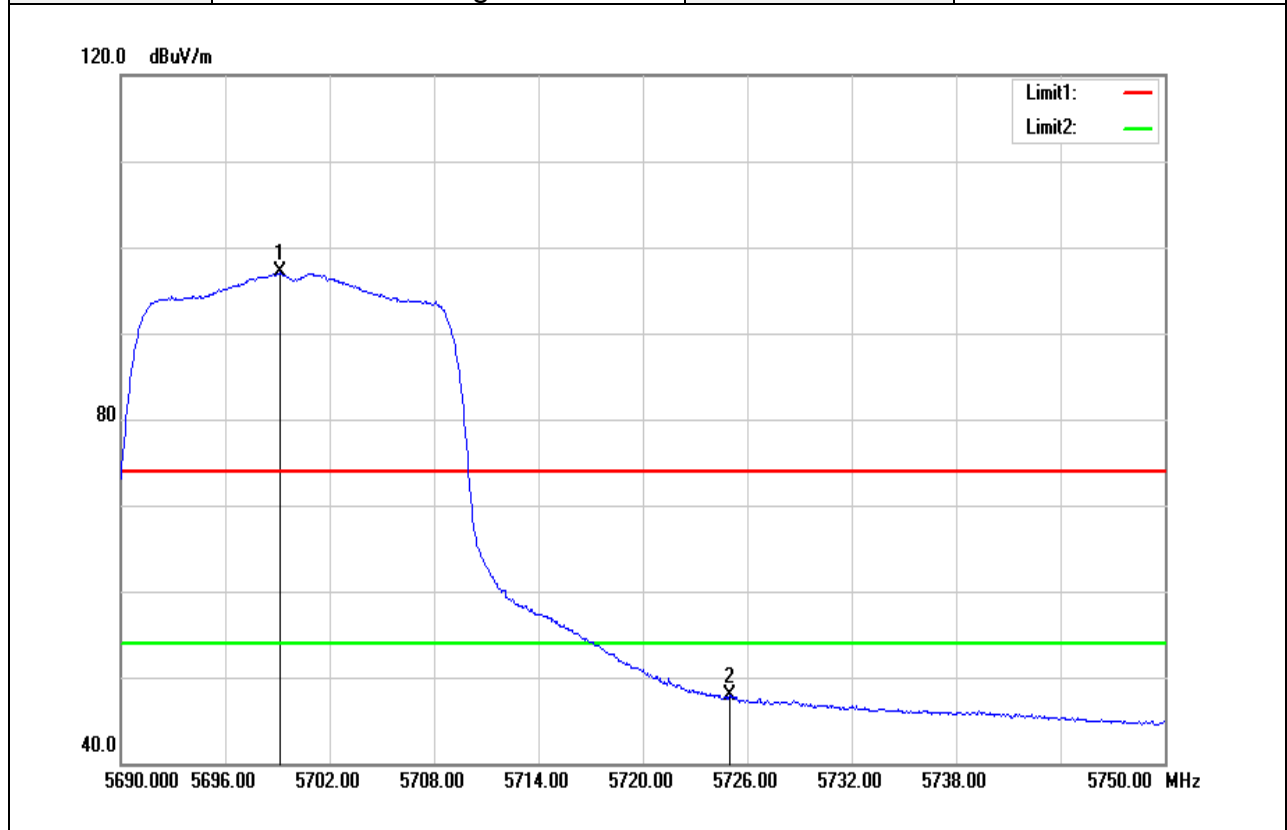

Frequency (MHz)	Reading (dBuV)	Correct Factor (dB/m)	Result (dBuV/m)	Limit (dBuV/m)	Margin (dB)	Remark
5699.120	90.37	6.65	97.02	-	-	AVG
5725.000	41.04	6.77	47.81	54.00	-6.19	AVG

Test Mode	IEEE 802.11n HT40 / 5510 MHz	Temp/Hum	23.2(°C)/ 52%RH
Test Item	Band Edge	Test Date	February 15, 2019
Polarize	Vertical	Test Engineer	Jerry Chuang
Detector	Peak		

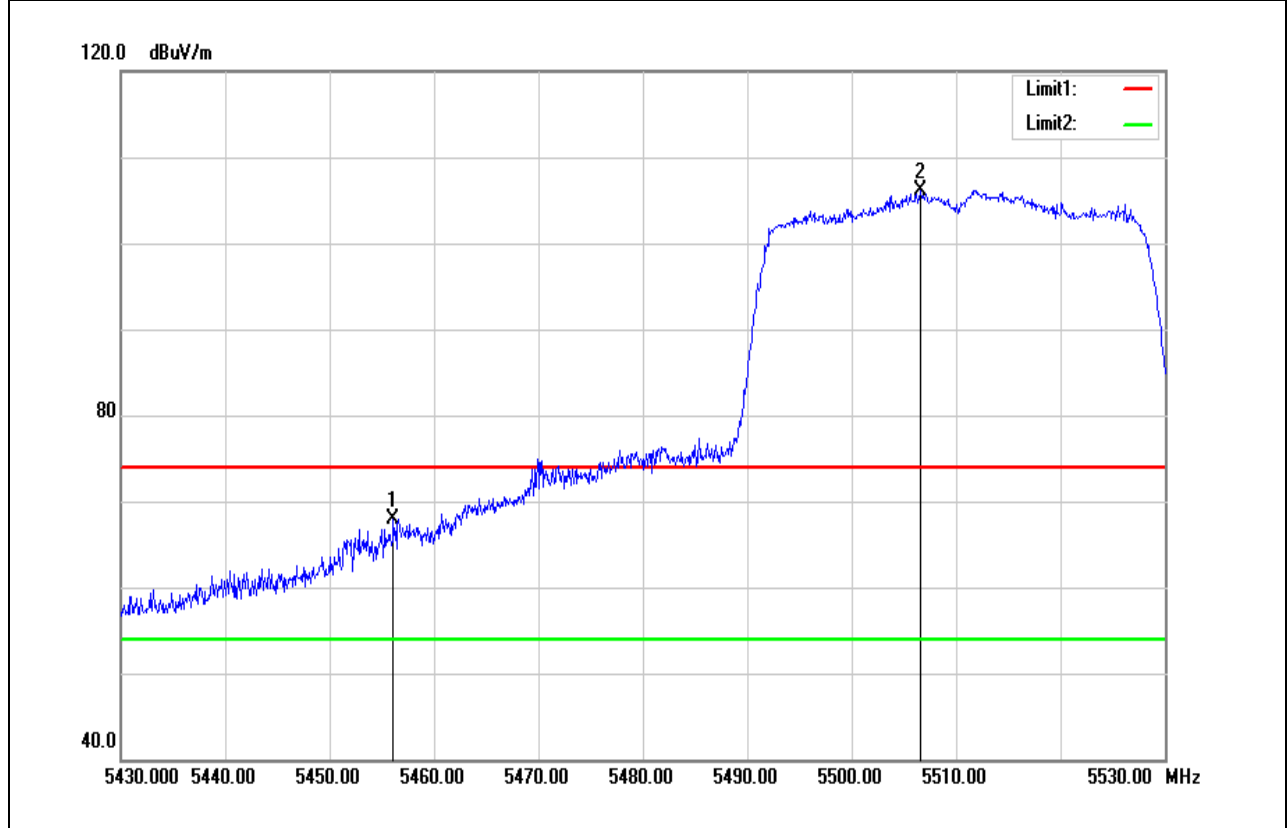

Frequency (MHz)	Reading (dBuV)	Correct Factor (dB/m)	Result (dBuV/m)	Limit (dBuV/m)	Margin (dB)	Remark
5456.100	62.19	5.66	67.85	74.00	-6.15	peak
5506.600	100.32	5.88	106.20	-	-	peak

Test Mode	IEEE 802.11n HT40 / 5510 MHz	Temperature	23.2(°C)/ 52%RH
Test Item	Band Edge	Test Date	February 15, 2019
Polarize	Vertical	Test Engineer	Jerry Chuang
Detector	Average		

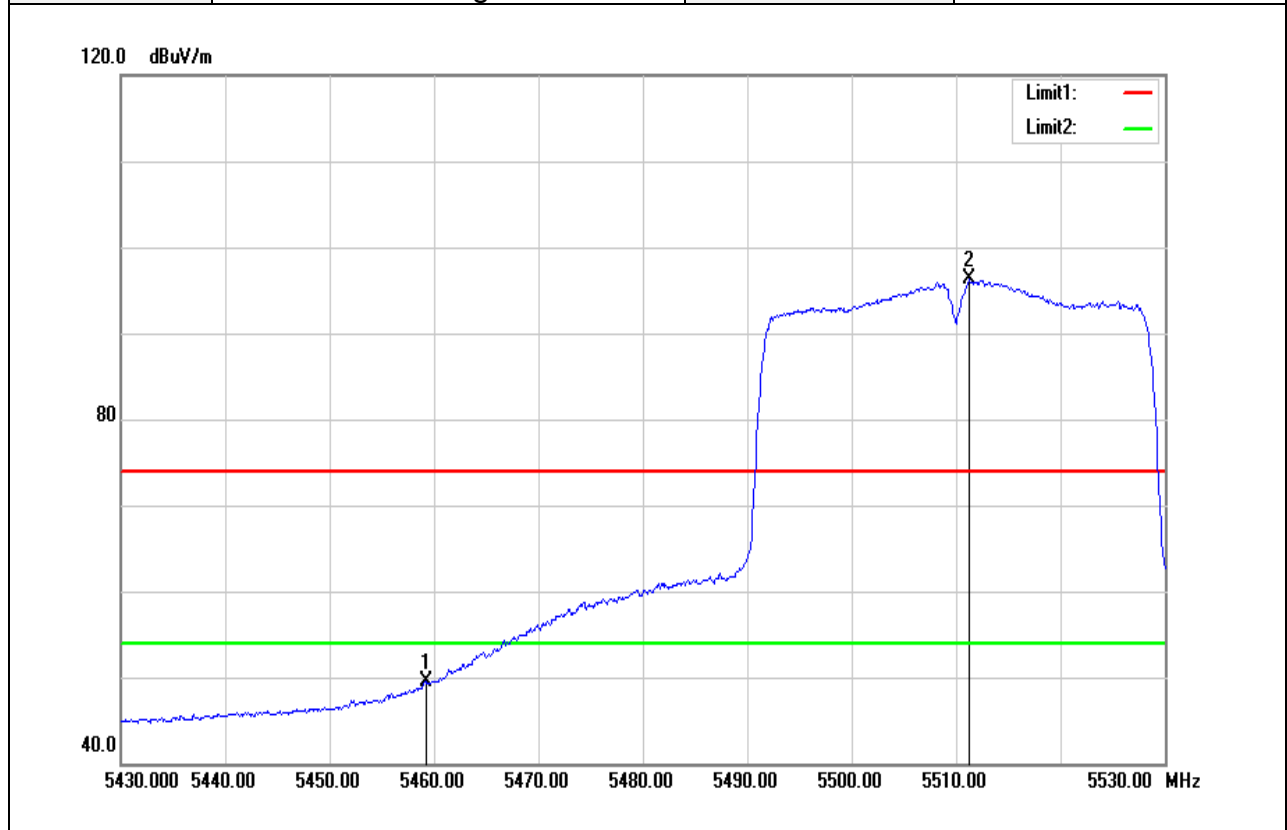

Frequency (MHz)	Reading (dBuV)	Correct Factor (dB/m)	Result (dBuV/m)	Limit (dBuV/m)	Margin (dB)	Remark
5459.200	43.91	5.68	49.59	54.00	-4.41	AVG
5511.300	90.38	5.90	96.28	-	-	AVG

Test Mode	IEEE 802.11n HT40 / 5670 MHz	Temp/Hum	23.2(°C)/ 52%RH
Test Item	Band Edge	Test Date	February 15, 2019
Polarize	Vertical	Test Engineer	Jerry Chuang
Detector	Peak		



Frequency (MHz)	Reading (dBuV)	Correct Factor (dB/m)	Result (dBuV/m)	Limit (dBuV/m)	Margin (dB)	Remark
5672.800	97.86	6.52	104.38	-	-	peak
5727.300	58.70	6.78	65.48	74.00	-8.52	peak

Test Mode	IEEE 802.11n HT40 / 5670 MHz	Temperature	23.2(°C)/ 52%RH
Test Item	Band Edge	Test Date	February 15, 2019
Polarize	Vertical	Test Engineer	Jerry Chuang
Detector	Average		

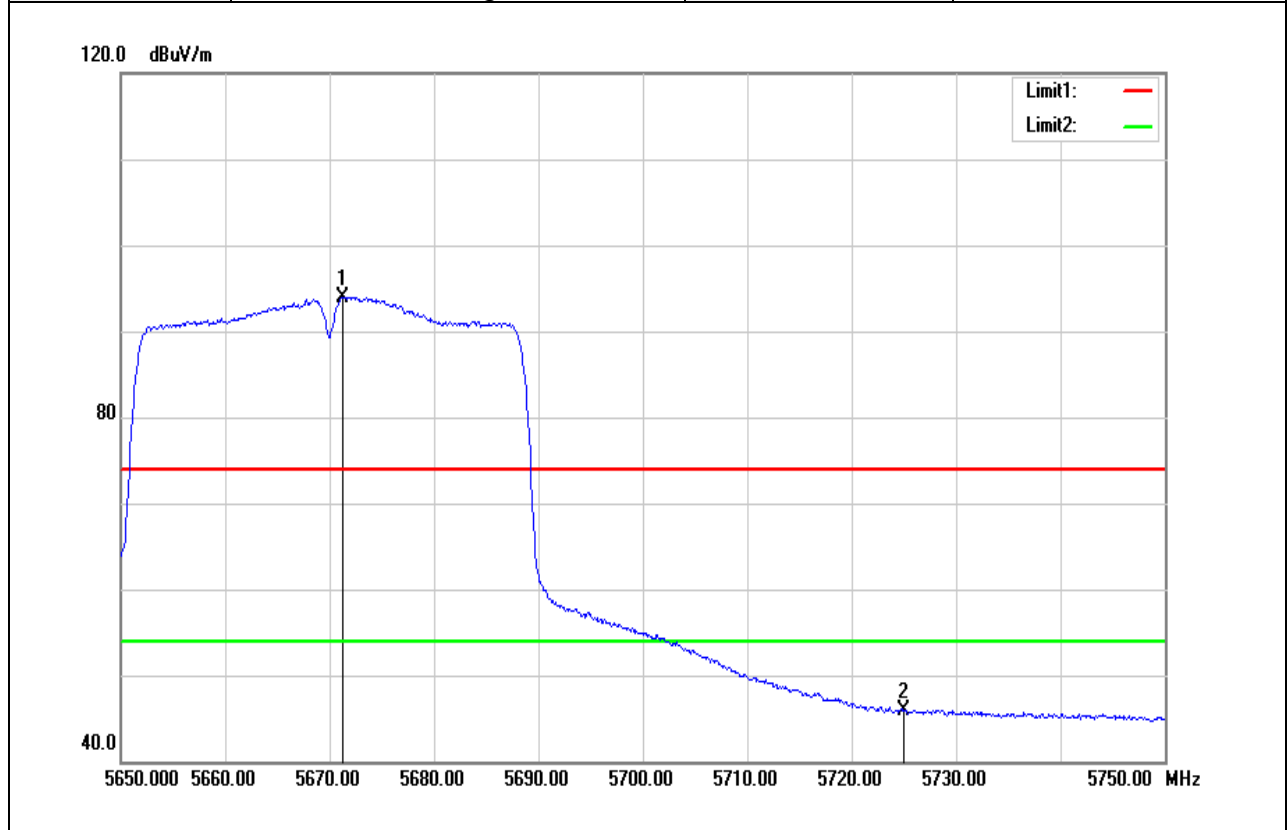

Frequency (MHz)	Reading (dBuV)	Correct Factor (dB/m)	Result (dBuV/m)	Limit (dBuV/m)	Margin (dB)	Remark
5671.300	87.48	6.52	94.00	-	-	AVG
5725.000	39.05	6.77	45.82	54.00	-8.18	AVG

Test Mode	IEEE 802.11ac VHT80 / 5530 MHz	Temp/Hum	23.2(°C)/ 52%RH
Test Item	Band Edge	Test Date	February 15, 2019
Polarize	Vertical	Test Engineer	Jerry Chuang
Detector	Peak		

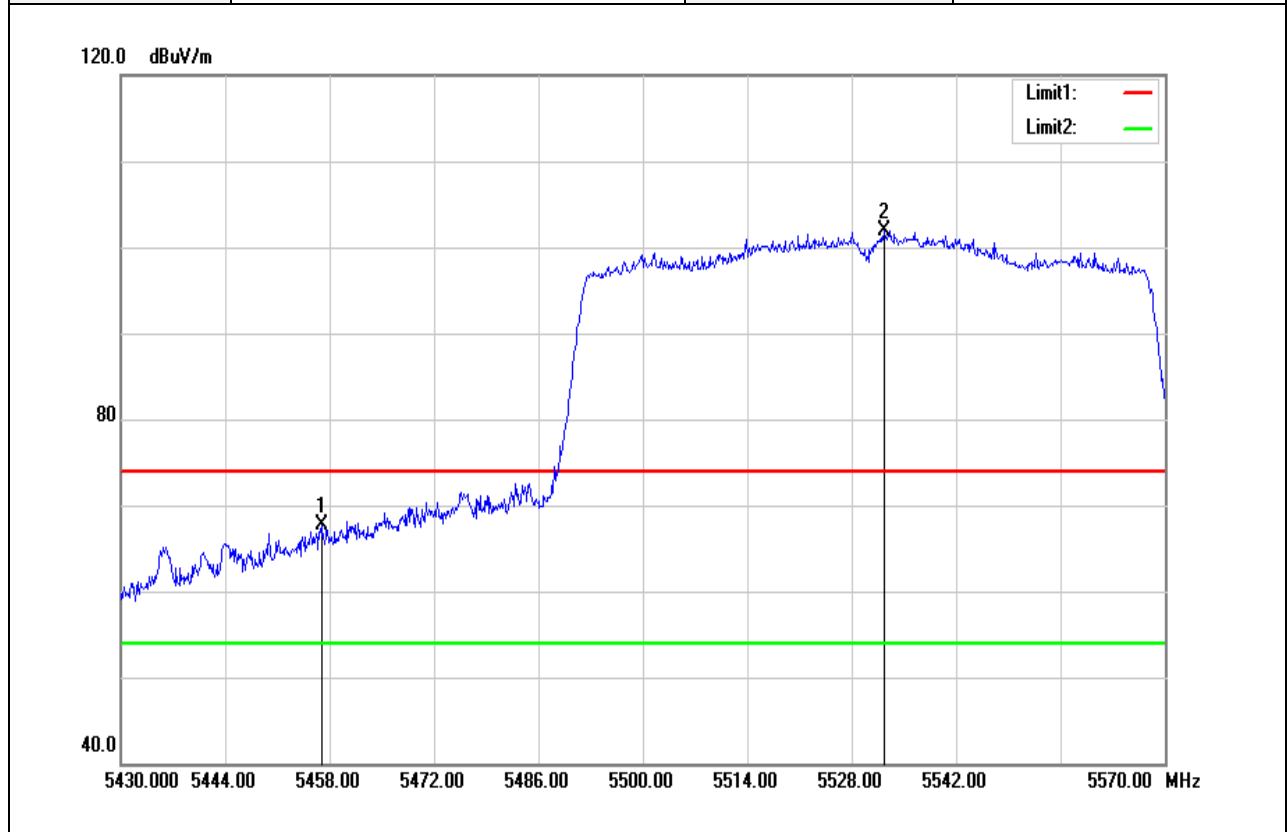

Frequency (MHz)	Reading (dBuV)	Correct Factor (dB/m)	Result (dBuV/m)	Limit (dBuV/m)	Margin (dB)	Remark
5456.880	62.00	5.66	67.66	74.00	-6.34	peak
5532.340	96.03	5.96	101.99	-	-	peak

Test Mode	IEEE 802.11ac VHT80 / 5530 MHz	Temperature	23.2(°C)/ 52%RH
Test Item	Band Edge	Test Date	February 15, 2019
Polarize	Vertical	Test Engineer	Jerry Chuang
Detector	Average		

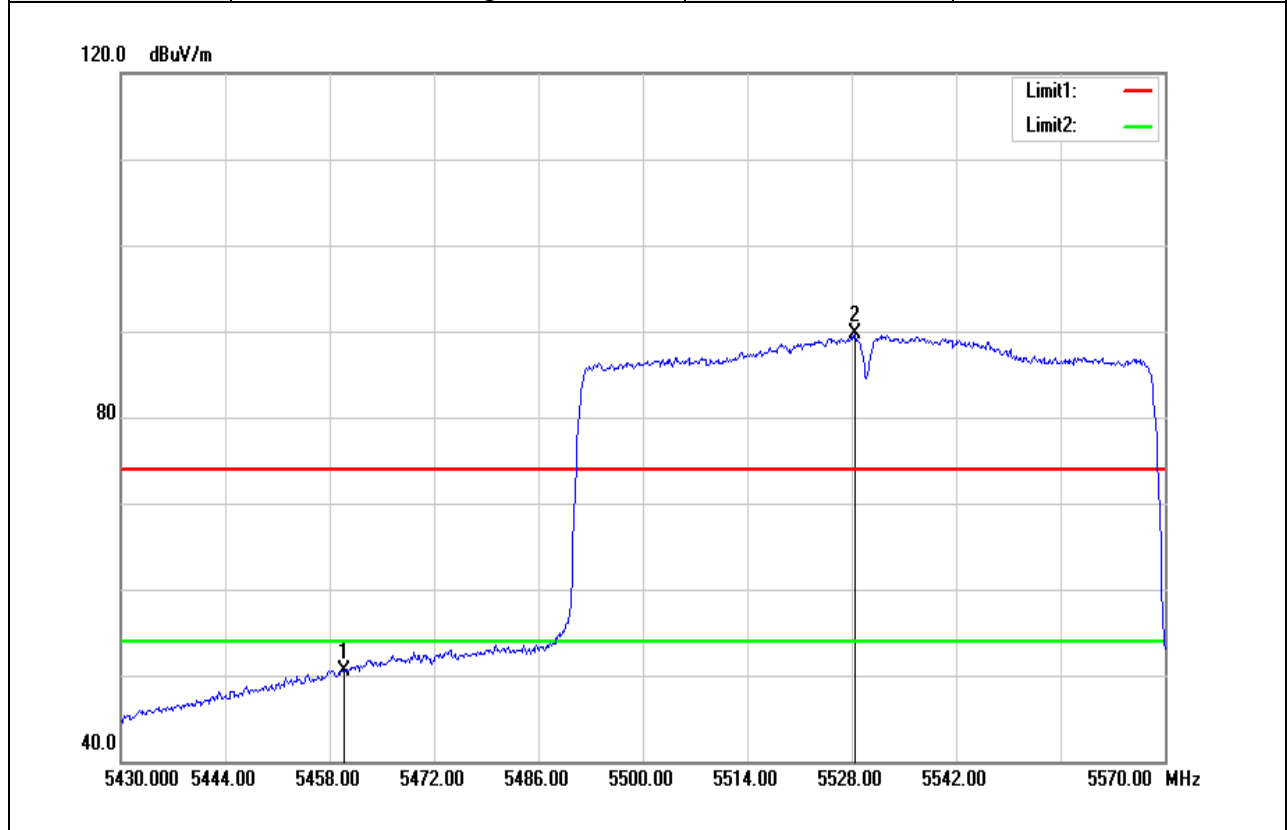

Frequency (MHz)	Reading (dBuV)	Correct Factor (dB/m)	Result (dBuV/m)	Limit (dBuV/m)	Margin (dB)	Remark
5460.000	44.89	5.68	50.57	54.00	-3.43	AVG
5528.420	83.70	5.95	89.65	-	-	AVG

Band Edge Test Data for UNII-3

Test Mode	IEEE 802.11a / 5745 MHz	Temp/Hum	23.2(°C)/ 52%RH
Test Item	Band Edge	Test Date	February 15, 2019
Polarize	Vertical	Test Engineer	Jerry Chuang
Detector	Peak		

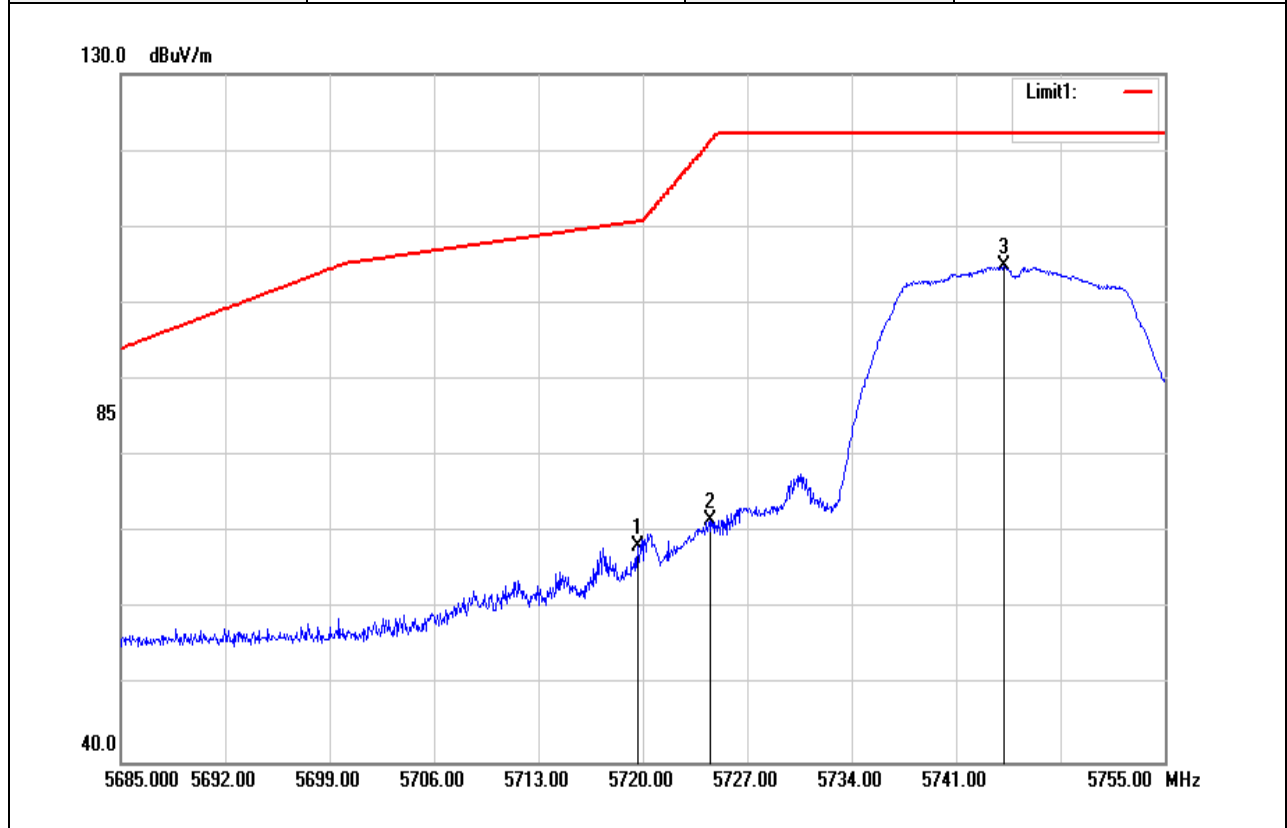

Frequency (MHz)	Reading (dBuV)	Correct Factor (dB/m)	Result (dBuV/m)	Limit (dBuV/m)	Margin (dB)	Remark
5719.650	61.54	6.75	68.29	110.70	-42.41	peak
5724.480	64.84	6.77	71.61	121.01	-49.40	peak
5744.220	97.95	6.86	104.81	-	-	peak

Test Mode	IEEE 802.11a / 5745 MHz	Temp/Hum	23.2(°C)/ 52%RH
Test Item	Band Edge	Test Date	February 15, 2019
Polarize	Vertical	Test Engineer	Jerry Chuang
Detector	Average		

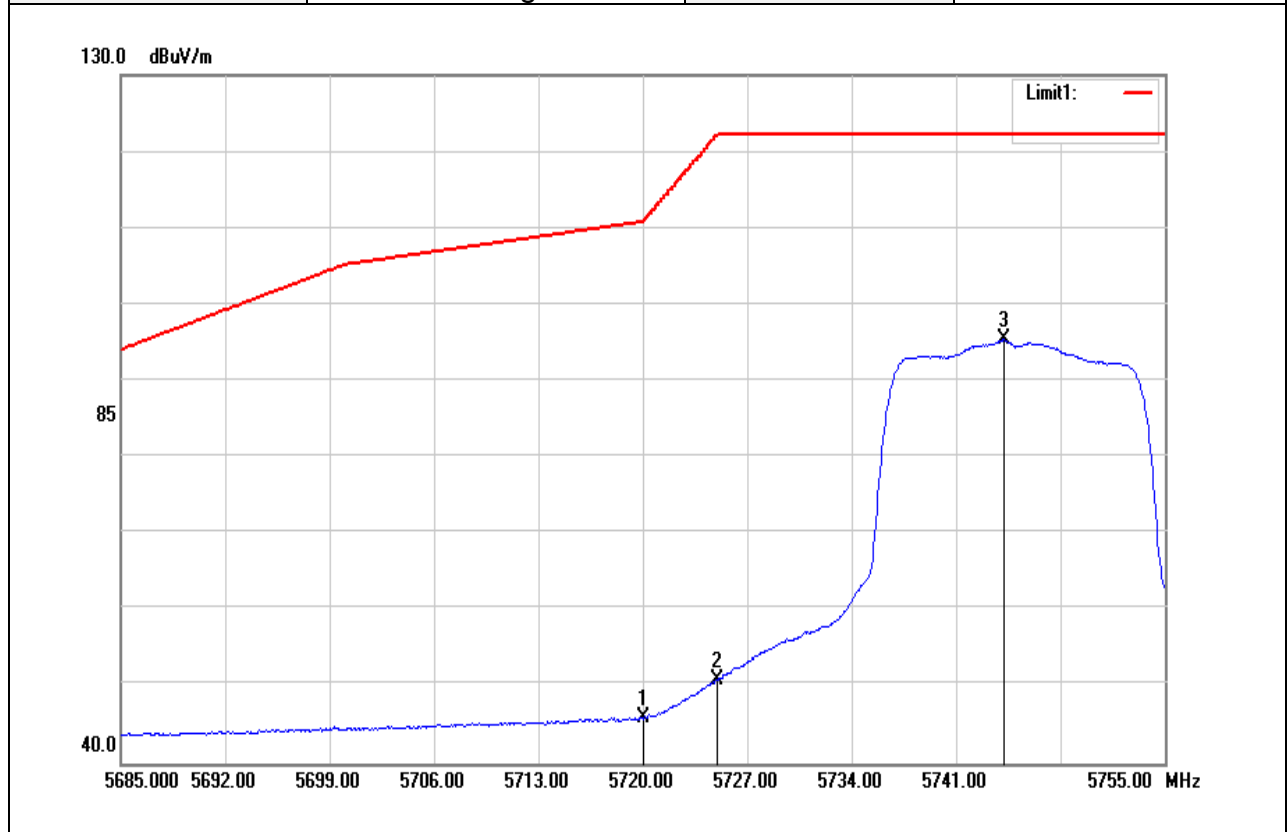

Frequency (MHz)	Reading (dBuV)	Correct Factor (dB/m)	Result (dBuV/m)	Limit (dBuV/m)	Margin (dB)	Remark
5720.070	39.22	6.75	45.97	110.96	-64.99	AVG
5724.970	44.14	6.77	50.91	122.13	-71.22	AVG
5744.220	88.57	6.86	95.43	-	-	AVG

Test Mode	IEEE 802.11a / 5825 MHz	Temp/Hum	23.2(°C)/ 52%RH
Test Item	Band Edge	Test Date	February 15, 2019
Polarize	Vertical	Test Engineer	Jerry Chuang
Detector	Peak		

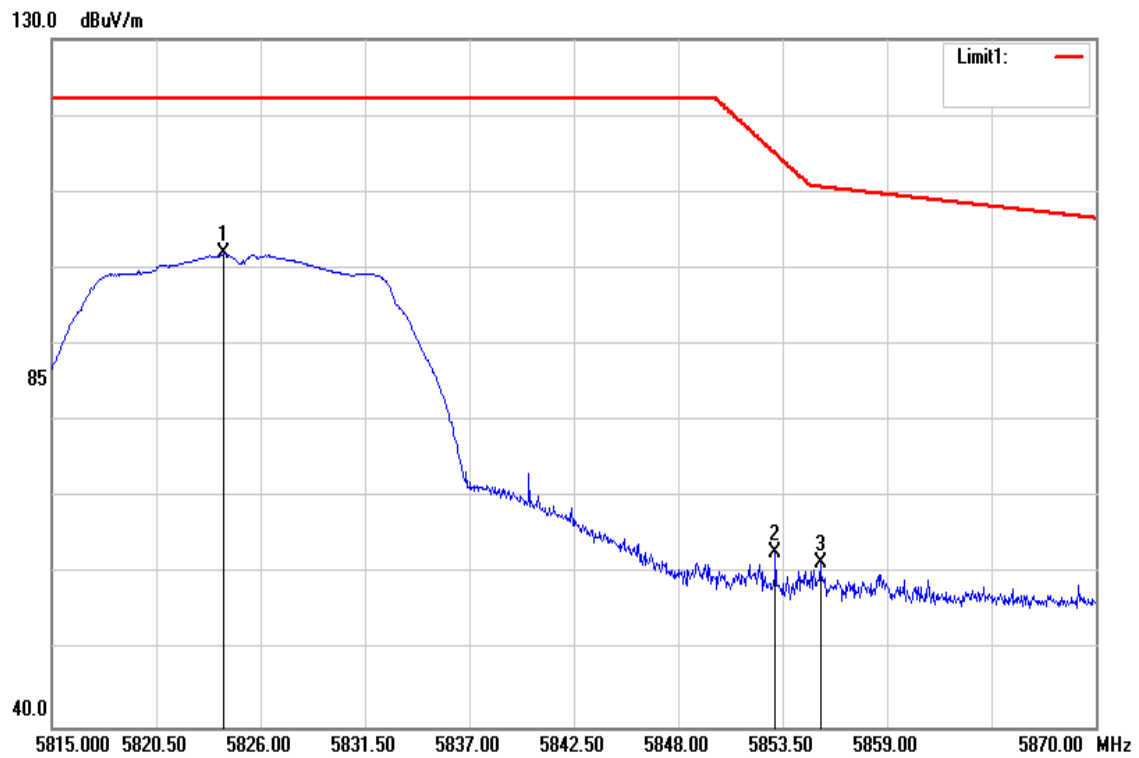

Frequency (MHz)	Reading (dBuV)	Correct Factor (dB/m)	Result (dBuV/m)	Limit (dBuV/m)	Margin (dB)	Remark
5824.020	94.79	7.14	101.93	-	-	peak
5853.115	55.67	7.15	62.82	115.10	-52.28	peak
5855.480	54.29	7.16	61.45	110.67	-49.22	peak

Test Mode	IEEE 802.11a / 5825 MHz	Temp/Hum	23.2(°C)/ 52%RH
Test Item	Band Edge	Test Date	February 15, 2019
Polarize	Vertical	Test Engineer	Jerry Chuang
Detector	Average		

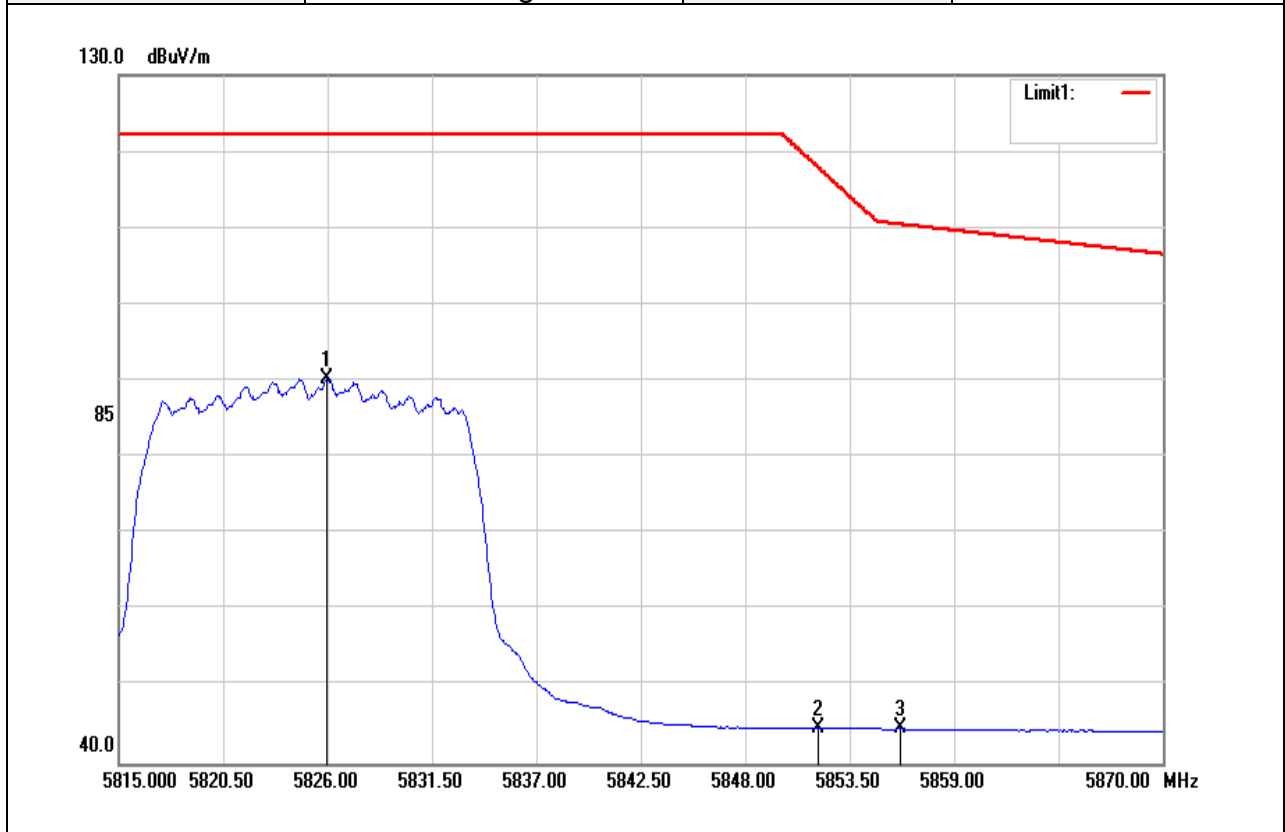

Frequency (MHz)	Reading (dBuV)	Correct Factor (dB/m)	Result (dBuV/m)	Limit (dBuV/m)	Margin (dB)	Remark
5825.945	83.15	7.14	90.29	-	-	AVG
5851.850	37.54	7.15	44.69	117.98	-73.29	AVG
5856.195	37.40	7.16	44.56	110.47	-65.91	AVG

Test Mode	IEEE 802.11n HT20 / 5745 MHz	Temp/Hum	23.2(°C)/ 52%RH
Test Item	Band Edge	Test Date	February 15, 2019
Polarize	Vertical	Test Engineer	Jerry Chuang
Detector	Peak		

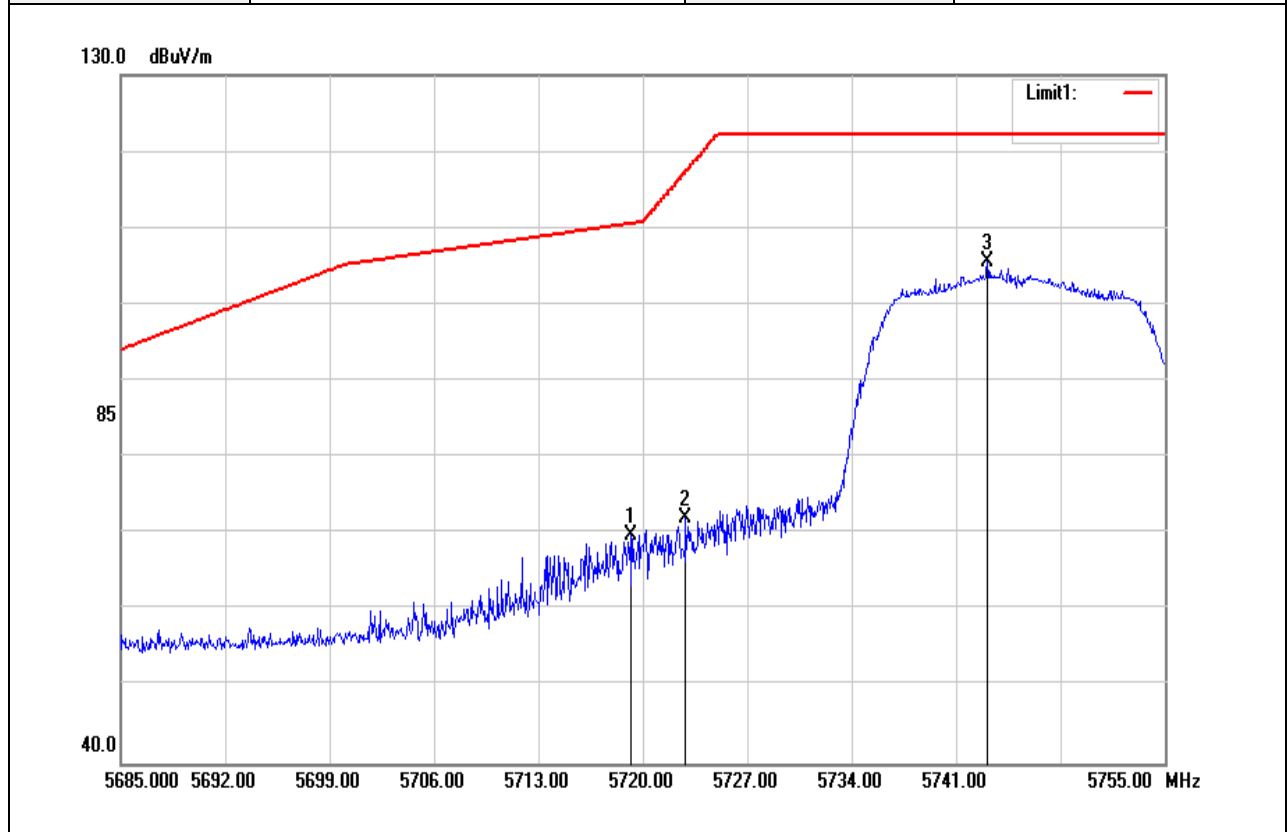

Frequency (MHz)	Reading (dBuV)	Correct Factor (dB/m)	Result (dBuV/m)	Limit (dBuV/m)	Margin (dB)	Remark
5719.160	63.07	6.75	69.82	110.56	-40.74	peak
5722.870	65.41	6.75	72.16	117.34	-45.18	peak
5743.100	98.83	6.85	105.68	-	-	peak

Test Mode	IEEE 802.11n HT20 / 5745 MHz	Temp/Hum	23.2(°C)/ 52%RH
Test Item	Band Edge	Test Date	February 15, 2019
Polarize	Vertical	Test Engineer	Jerry Chuang
Detector	Average		

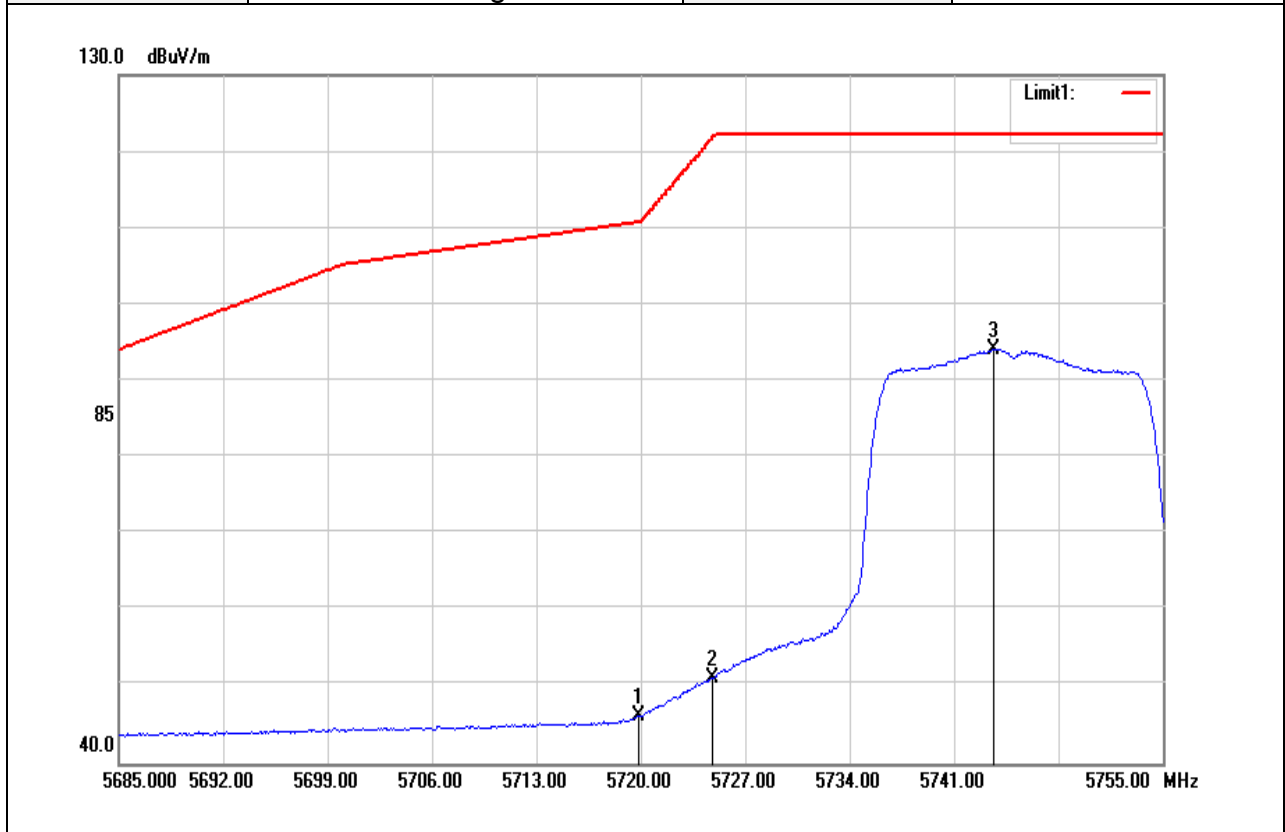

Frequency (MHz)	Reading (dBuV)	Correct Factor (dB/m)	Result (dBuV/m)	Limit (dBuV/m)	Margin (dB)	Remark
5719.860	39.54	6.75	46.29	110.76	-64.47	AVG
5724.830	44.48	6.77	51.25	121.81	-70.56	AVG
5743.660	87.33	6.86	94.19	-	-	AVG

Test Mode	IEEE 802.11n HT20 / 5825 MHz	Temp/Hum	23.2(°C)/ 52%RH
Test Item	Band Edge	Test Date	February 15, 2019
Polarize	Vertical	Test Engineer	Jerry Chuang
Detector	Peak		

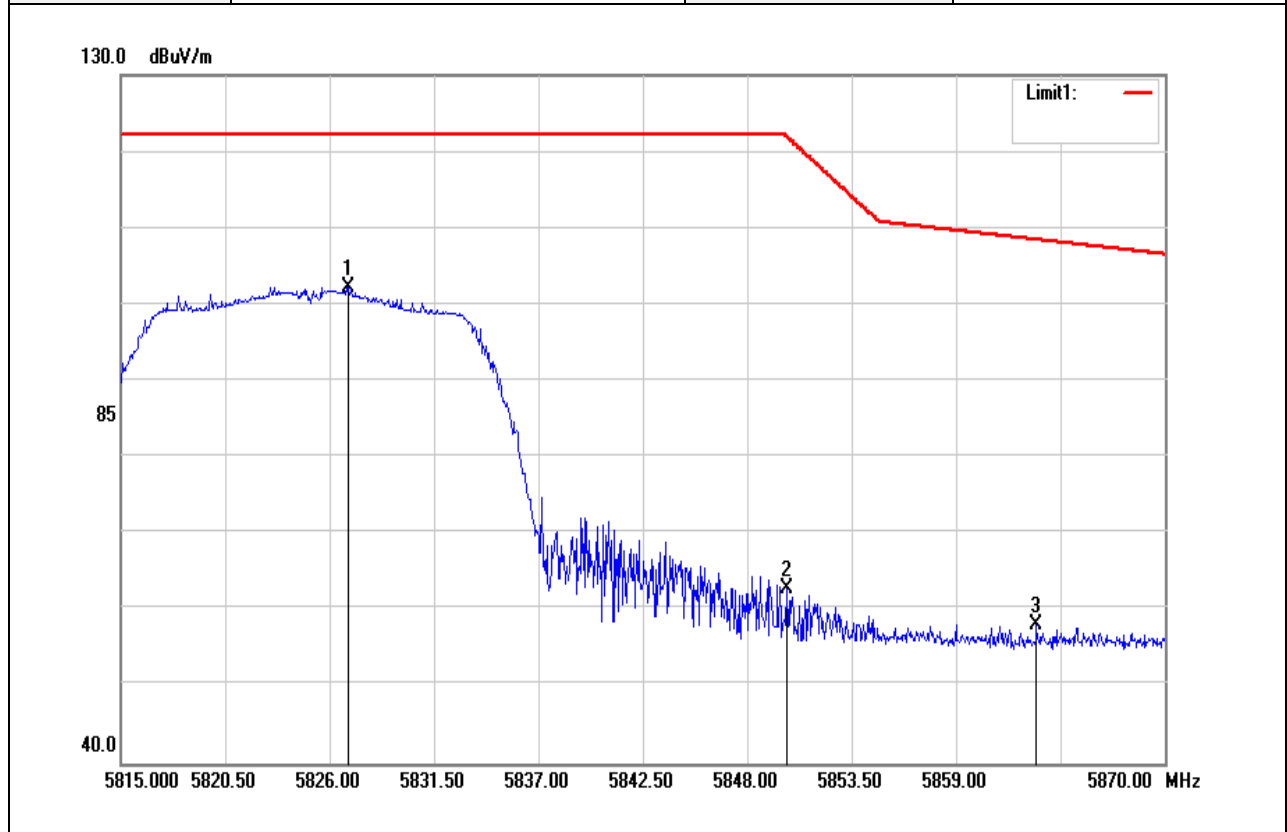

Frequency (MHz)	Reading (dBuV)	Correct Factor (dB/m)	Result (dBuV/m)	Limit (dBuV/m)	Margin (dB)	Remark
5826.990	95.10	7.14	102.24	-	-	peak
5850.090	55.61	7.16	62.77	121.99	-59.22	peak
5863.235	51.03	7.16	58.19	108.49	-50.30	peak

Test Mode	IEEE 802.11n HT20 / 5825 MHz	Temp/Hum	23.2(°C)/ 52%RH
Test Item	Band Edge	Test Date	February 15, 2019
Polarize	Vertical	Test Engineer	Jerry Chuang
Detector	Average		

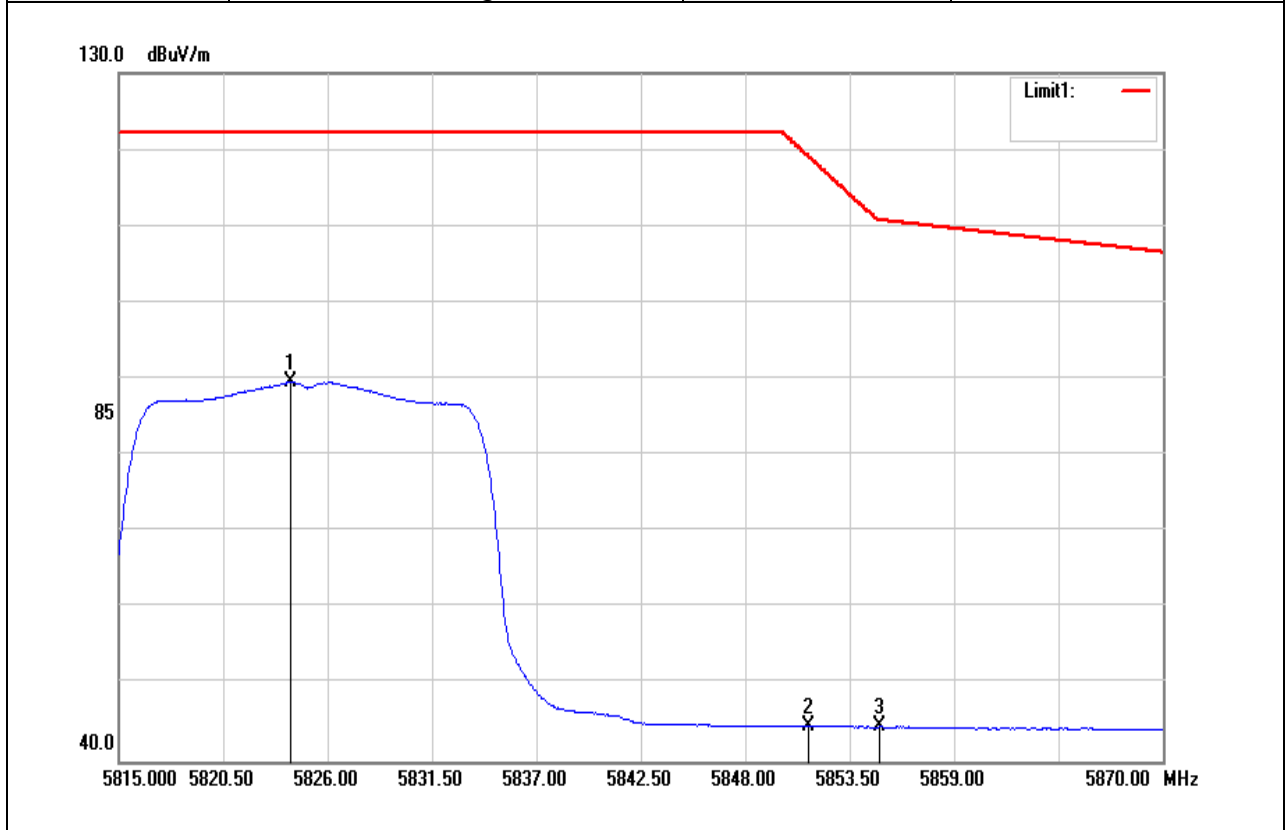

Frequency (MHz)	Reading (dBuV)	Correct Factor (dB/m)	Result (dBuV/m)	Limit (dBuV/m)	Margin (dB)	Remark
5824.075	82.50	7.14	89.64	-	-	AVG
5851.300	37.47	7.15	44.62	119.24	-74.62	AVG
5855.095	37.42	7.16	44.58	110.77	-66.19	AVG

Test Mode	IEEE 802.11n HT40/ 5755 MHz	Temp/Hum	23.2(°C)/ 52%RH
Test Item	Band Edge	Test Date	February 15, 2019
Polarize	Vertical	Test Engineer	Jerry Chuang
Detector	Peak		

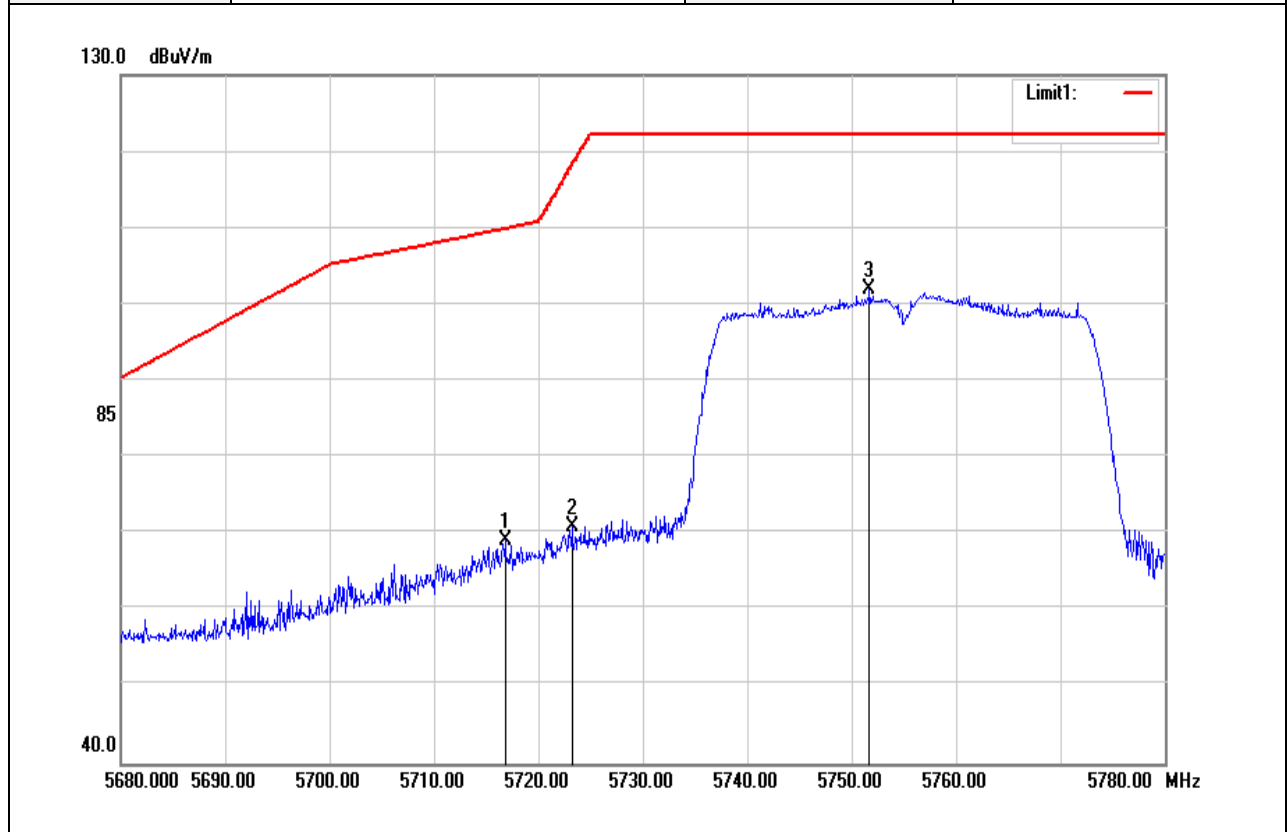

Frequency (MHz)	Reading (dBuV)	Correct Factor (dB/m)	Result (dBuV/m)	Limit (dBuV/m)	Margin (dB)	Remark
5716.800	62.40	6.73	69.13	109.90	-40.77	peak
5723.200	64.29	6.75	71.04	118.10	-47.06	peak
5751.700	95.06	6.90	101.96	-	-	peak

Test Mode	IEEE 802.11n HT40/ 5755 MHz	Temp/Hum	23.2(°C)/ 52%RH
Test Item	Band Edge	Test Date	February 15, 2019
Polarize	Vertical	Test Engineer	Jerry Chuang
Detector	Average		

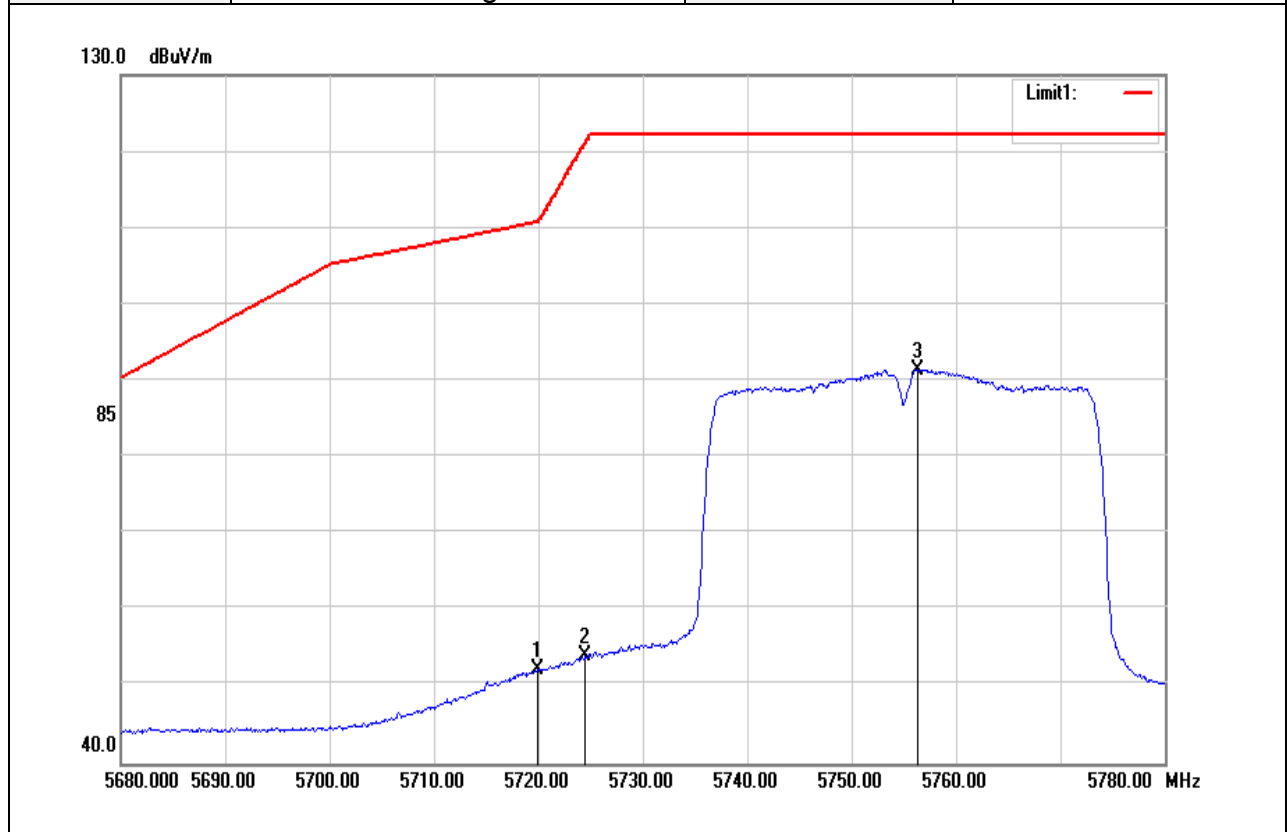

Frequency (MHz)	Reading (dBuV)	Correct Factor (dB/m)	Result (dBuV/m)	Limit (dBuV/m)	Margin (dB)	Remark
5719.900	45.47	6.75	52.22	110.77	-58.55	AVG
5724.500	47.21	6.77	53.98	121.06	-67.08	AVG
5756.300	84.59	6.91	91.50	-	-	AVG

Test Mode	IEEE 802.11n HT40/ 5795 MHz	Temp/Hum	23.2(°C)/ 52%RH
Test Item	Band Edge	Test Date	February 15, 2019
Polarize	Vertical	Test Engineer	Jerry Chuang
Detector	Peak		

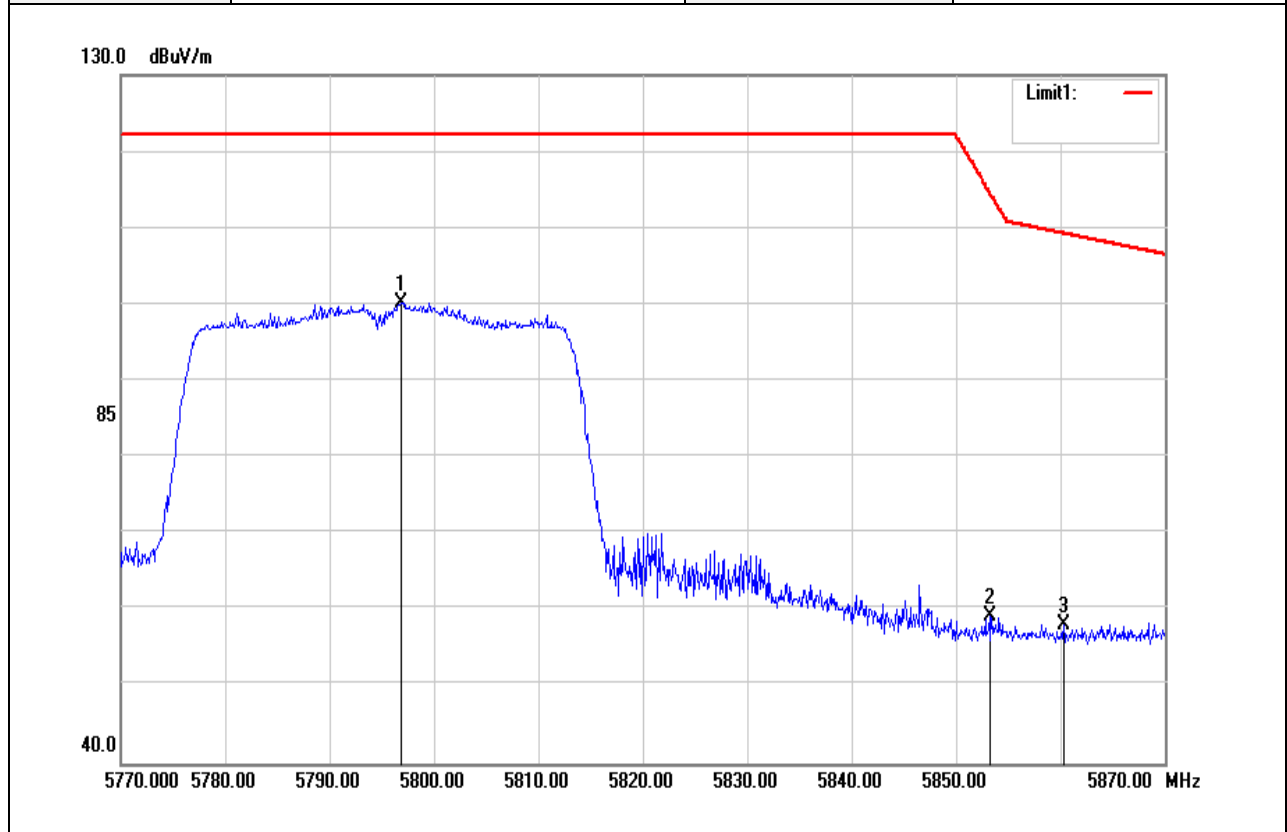

Frequency (MHz)	Reading (dBuV)	Correct Factor (dB/m)	Result (dBuV/m)	Limit (dBuV/m)	Margin (dB)	Remark
5796.800	93.15	7.11	100.26	-	-	peak
5853.200	52.09	7.15	59.24	114.90	-55.66	peak
5860.300	50.92	7.16	58.08	109.32	-51.24	peak

Test Mode	IEEE 802.11n HT40/ 5795 MHz	Temp/Hum	23.2(°C)/ 52%RH
Test Item	Band Edge	Test Date	February 15, 2019
Polarize	Vertical	Test Engineer	Jerry Chuang
Detector	Average		

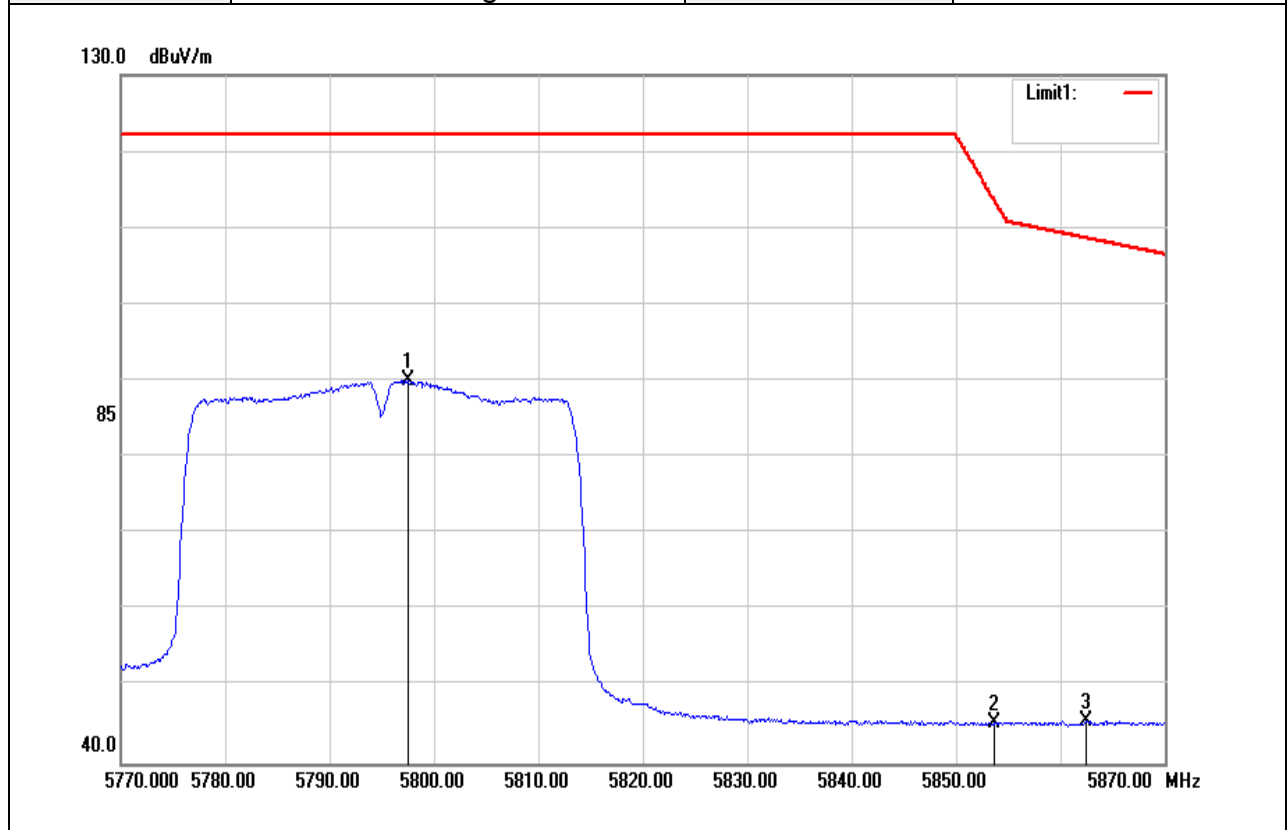

Frequency (MHz)	Reading (dBuV)	Correct Factor (dB/m)	Result (dBuV/m)	Limit (dBuV/m)	Margin (dB)	Remark
5797.500	82.94	7.11	90.05	-	-	AVG
5853.700	38.24	7.15	45.39	113.76	-68.37	AVG
5862.500	38.37	7.17	45.54	108.70	-63.16	AVG

Report No.: T181222W01-RP4

Test Mode	IEEE 802.11ac VHT80 / 5775 MHz	Temp/Hum	23.2(°C)/ 52%RH
Test Item	Band Edge	Test Date	February 15, 2019
Polarize	Vertical	Test Engineer	Jerry Chuang
Detector	Peak		

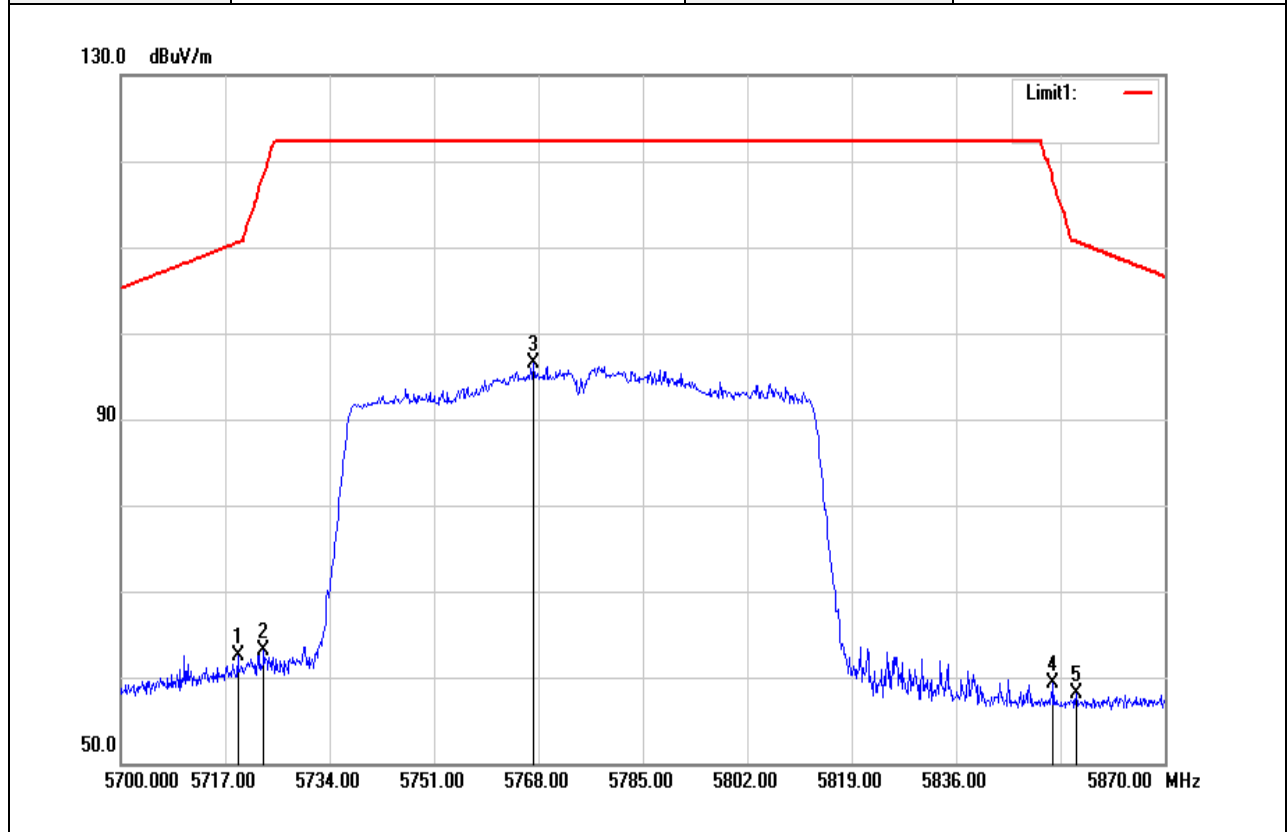

Frequency (MHz)	Reading (dBuV)	Correct Factor (dB/m)	Result (dBuV/m)	Limit (dBuV/m)	Margin (dB)	Remark
5719.040	55.79	6.75	62.54	110.53	-47.99	peak
5723.290	56.34	6.75	63.09	118.30	-55.21	peak
5767.150	89.59	6.97	96.56	-	-	peak
5851.810	52.22	7.15	59.37	118.07	-58.70	peak
5855.550	50.86	7.16	58.02	110.65	-52.63	peak

Test Mode	IEEE 802.11ac VHT80 / 5775 MHz	Temp/Hum	23.2(°C)/ 52%RH
Test Item	Band Edge	Test Date	February 15, 2019
Polarize	Vertical	Test Engineer	Jerry Chuang
Detector	Average		

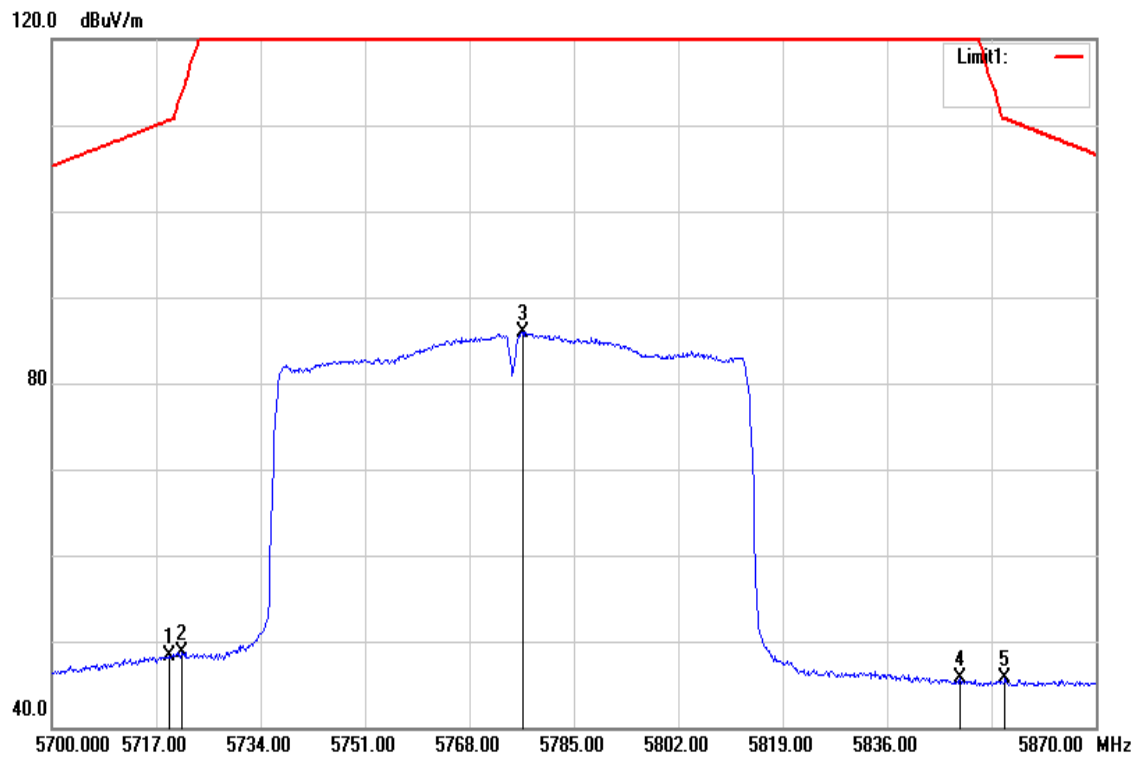

Frequency (MHz)	Reading (dBuV)	Correct Factor (dB/m)	Result (dBuV/m)	Limit (dBuV/m)	Margin (dB)	Remark
5719.210	41.57	6.75	48.32	110.58	-62.26	AVG
5721.080	42.05	6.74	48.79	113.26	-64.47	AVG
5776.670	78.92	7.02	85.94	-	-	AVG
5847.900	38.48	7.16	45.64	122.20	-76.56	AVG
5855.210	38.60	7.16	45.76	110.74	-64.98	AVG

Below 1G Test Data

Test Mode	IEEE 802.11ac VHT80 / 5210MHZ	Temp/Hum	22.7(°C)/ 52%RH
Test Item	30MHz-1GHz	Test Date	January 19, 2019
Polarize	Horizontal	Test Engineer	Jerry Chuang
Detector	Peak and Quasi-peak		

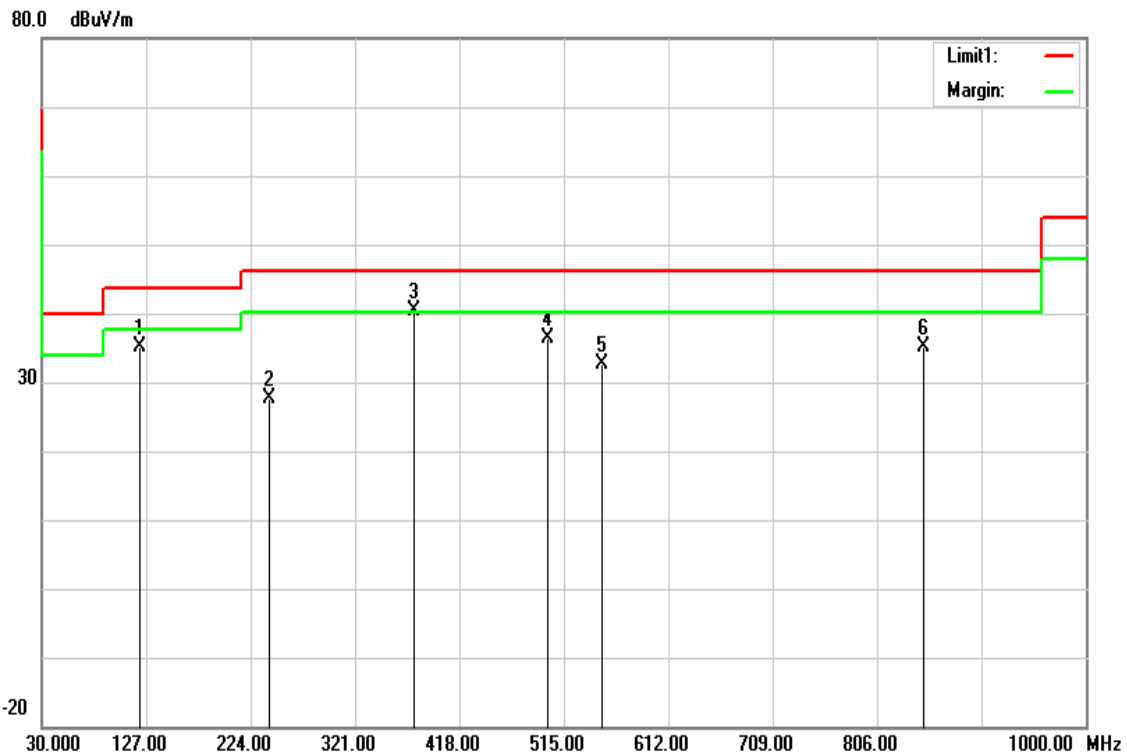

Frequency (MHz)	Reading (dBuV)	Correct Factor (dB/m)	Result (dBuV/m)	Limit (dBuV/m)	Margin (dB)	Remark
121.1800	43.48	-8.44	35.04	43.52	-8.48	peak
241.4600	37.17	-9.60	27.57	46.02	-18.45	peak
375.3200	45.87	-5.58	40.29	46.02	-5.73	peak
500.4500	38.56	-2.28	36.28	46.02	-9.74	peak
549.9200	34.14	-1.41	32.73	46.02	-13.29	peak
849.6500	31.26	3.83	35.09	46.02	-10.93	peak

Test Mode	IEEE 802.11ac VHT80 / 5210MHZ	Temp/Hum	22.7(°C)/ 52%RH
Test Item	30MHz-1GHz	Test Date	January 19, 2019
Polarize	Horizontal	Test Engineer	Jerry Chuang
Detector	Peak and Quasi-peak		

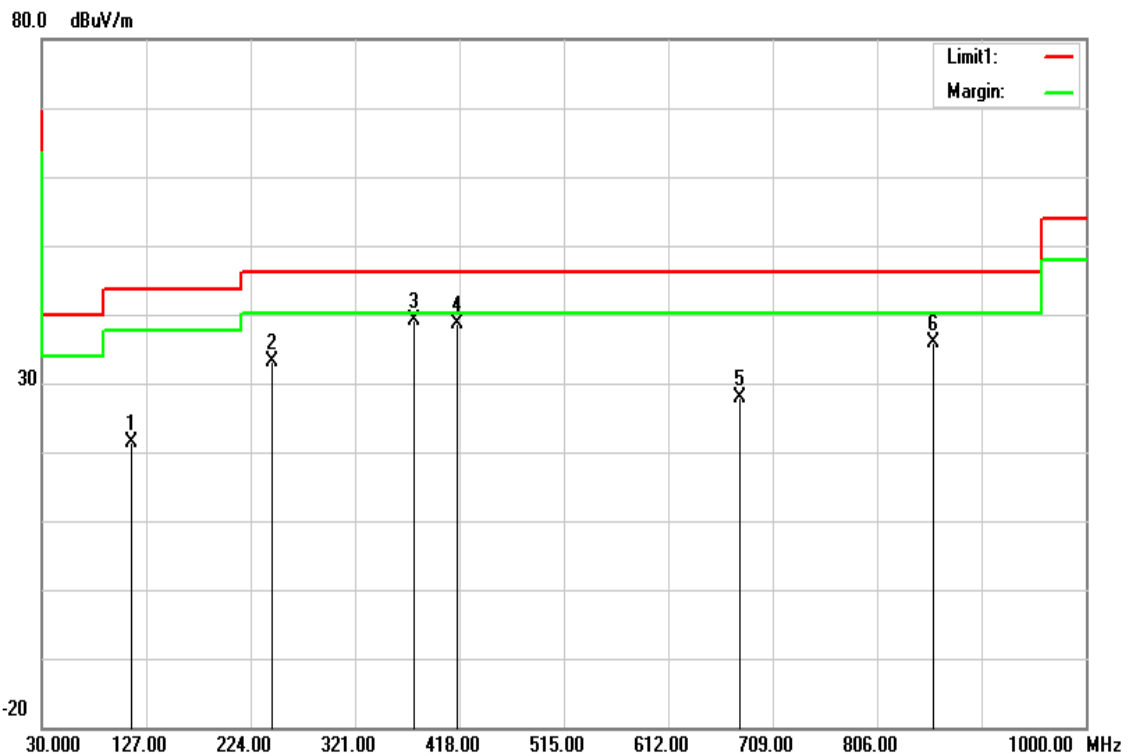

Frequency (MHz)	Reading (dBuV)	Correct Factor (dB/m)	Result (dBuV/m)	Limit (dBuV/m)	Margin (dB)	Remark
113.4200	31.11	-9.61	21.50	43.52	-22.02	peak
244.3700	42.56	-9.51	33.05	46.02	-12.97	peak
376.2900	44.77	-5.57	39.20	46.02	-6.82	peak
416.0600	42.85	-4.16	38.69	46.02	-7.33	peak
678.9300	27.21	0.79	28.00	46.02	-18.02	peak
858.3800	32.06	3.87	35.93	46.02	-10.09	peak

Above 1G Test Data for UNII-1

Test Mode	IEEE 802.11a / 5180MHZ	Temp/Hum	23.2(°C)/ 52%RH
Test Item	Harmonic	Test Date	February 15, 2019
Polarize	Vertical	Test Engineer	Jerry Chuang
Detector	Peak		

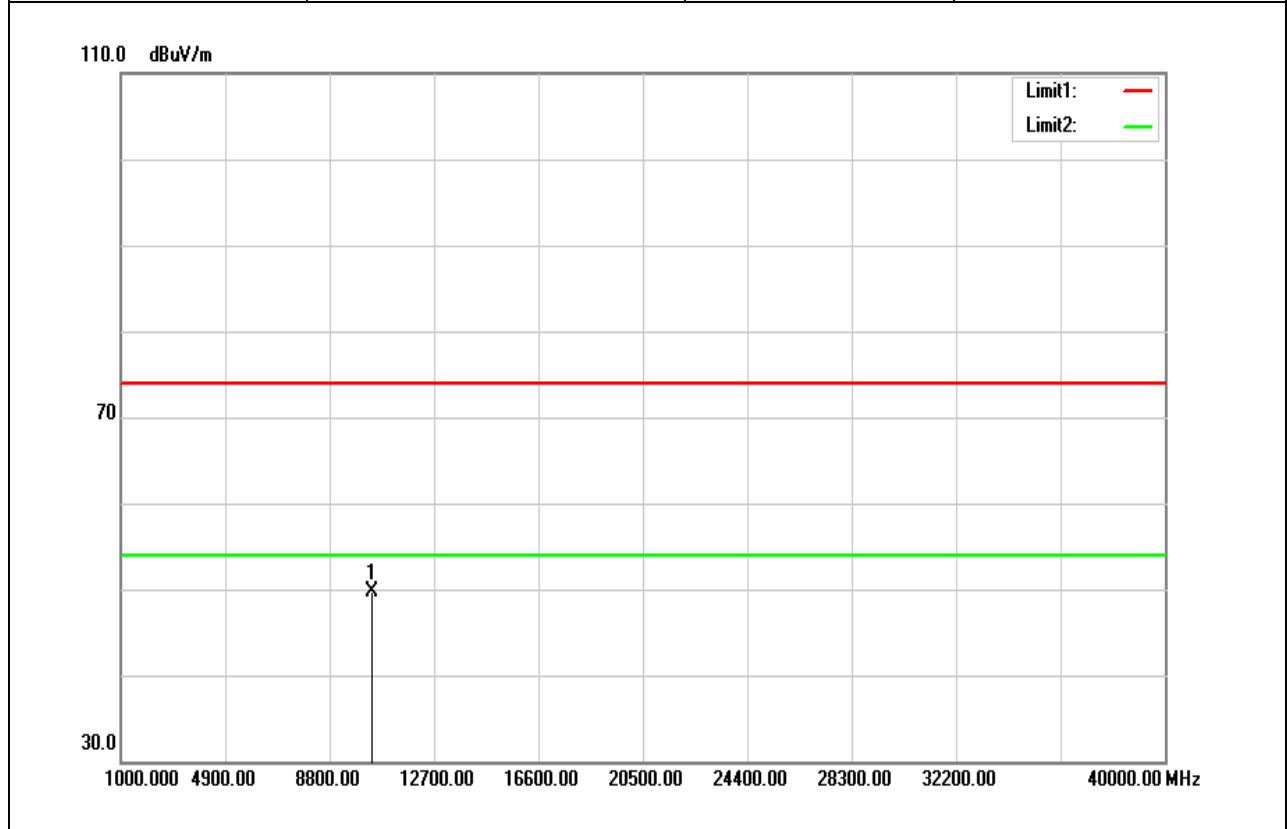

Frequency (MHz)	Reading (dBuV)	Correct Factor (dB/m)	Result (dBuV/m)	Limit (dBuV/m)	Margin (dB)	Remark
10360.000	35.00	14.75	49.75	74.00	-24.25	peak
N/A						

Remark:

- Measuring frequencies from 1 GHz to the 10th harmonic of highest fundamental frequency.
- For above 1GHz, the EUT peak value was under average limit, therefore the Average value compliance with the average limit

Test Mode	IEEE 802.11a / 5180MHZ	Temp/Hum	23.2(°C)/ 52%RH
Test Item	Harmonic	Test Date	February 15, 2019
Polarize	Horizontal	Test Engineer	Jerry Chuang
Detector	Peak		

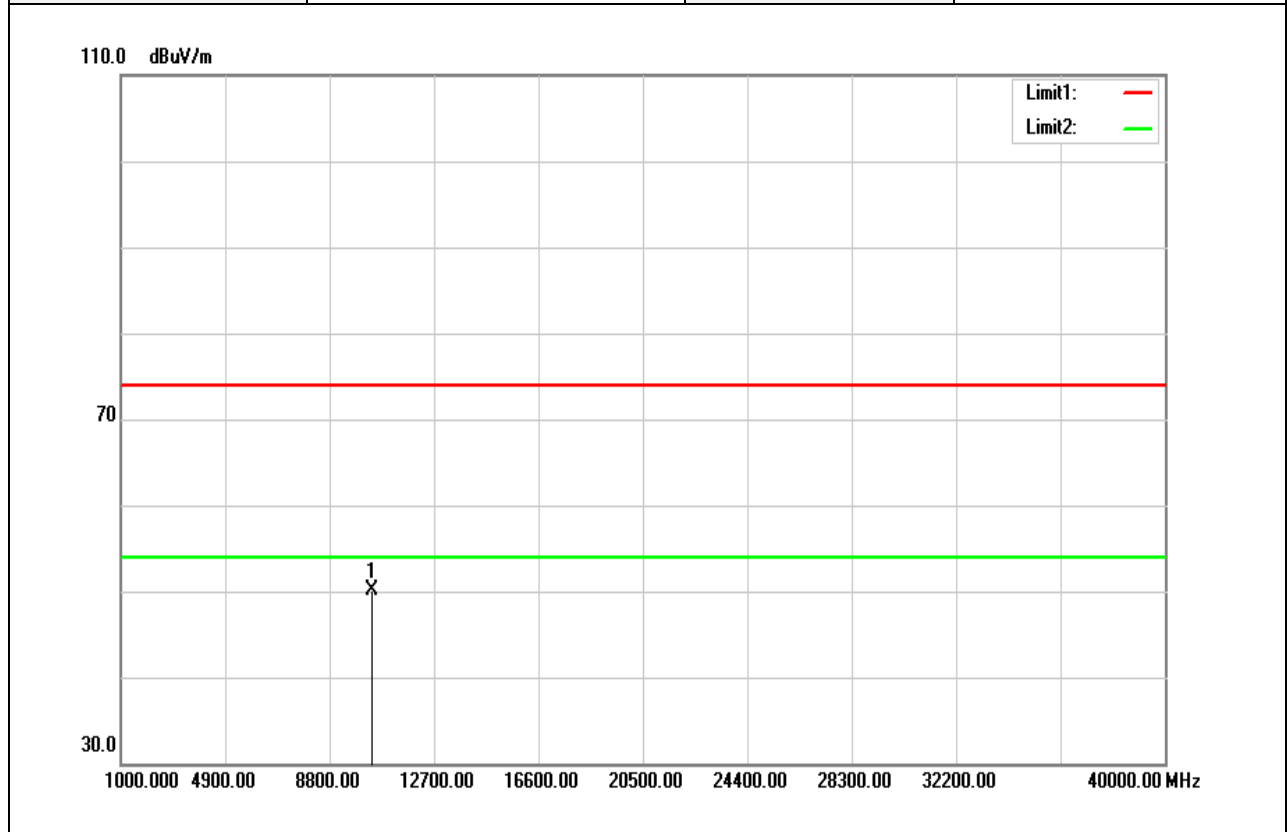

Frequency (MHz)	Reading (dBuV)	Correct Factor (dB/m)	Result (dBuV/m)	Limit (dBuV/m)	Margin (dB)	Remark
10360.000	35.33	14.75	50.08	74.00	-23.92	peak
N/A						

Remark:

- Measuring frequencies from 1 GHz to the 10th harmonic of highest fundamental frequency.
- For above 1GHz, the EUT peak value was under average limit, therefore the Average value compliance with the average limit

Test Mode	IEEE 802.11a / 5220 MHz	Temp/Hum	23.2(°C) / 52%RH
Test Item	Horizontal	Test Date	February 15, 2019
Polarize	Vertical	Test Engineer	Jerry Chuang
Detector	Peak		

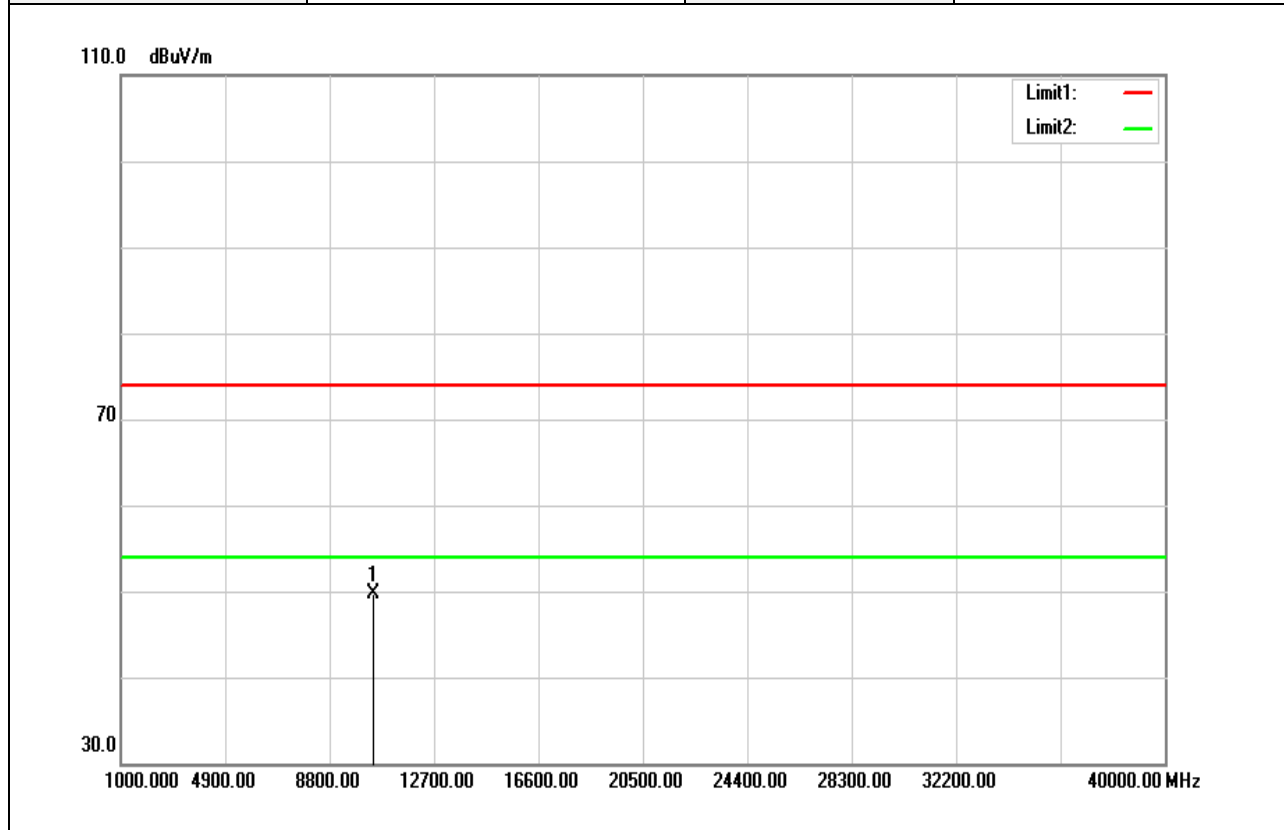

Frequency (MHz)	Reading (dBuV)	Correct Factor (dB/m)	Result (dBuV/m)	Limit (dBuV/m)	Margin (dB)	Remark
10440.000	34.74	15.00	49.74	74.00	-24.26	peak
N/A						

Remark:

1. Measuring frequencies from 1 GHz to the 10th harmonic of highest fundamental frequency.
2. For above 1GHz, the EUT peak value was under average limit, therefore the Average value compliance with the average limit

Test Mode	IEEE 802.11a / 5220 MHz	Temp/Hum	23.2(°C) / 52%RH
Test Item	Harmonic	Test Date	February 15, 2019
Polarize	Horizontal	Test Engineer	Jerry Chuang
Detector	Peak		

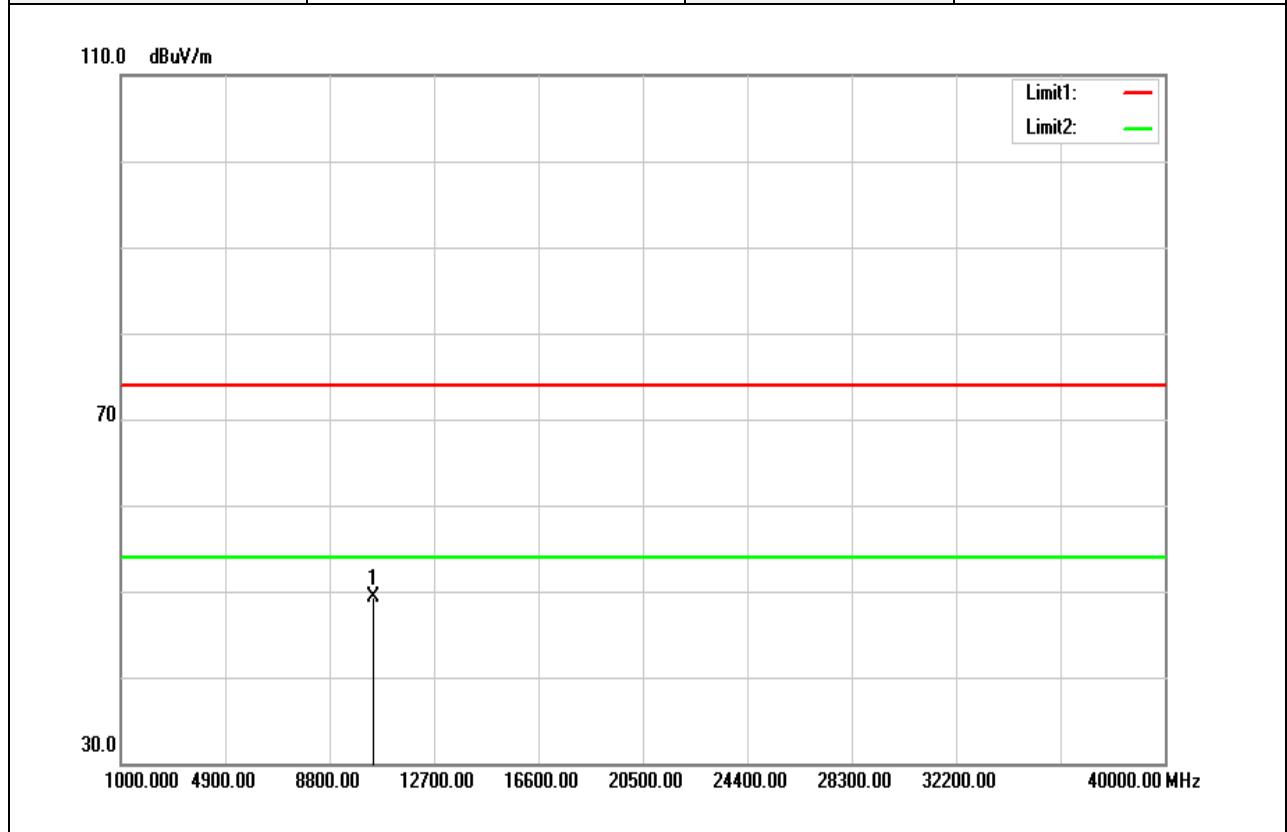

Frequency (MHz)	Reading (dBuV)	Correct Factor (dB/m)	Result (dBuV/m)	Limit (dBuV/m)	Margin (dB)	Remark
10440.000	34.20	15.00	49.20	74.00	-24.80	peak
N/A						

Remark:

- Measuring frequencies from 1 GHz to the 10th harmonic of highest fundamental frequency.
- For above 1GHz, the EUT peak value was under average limit, therefore the Average value compliance with the average limit