

# IPJ-RS500-GX, IPJ-RS500-EU Electrical, Mechanical, & Thermal Specification

## Indy® RS500 Overview

Indy RS500 is a completely integrated UHF reader SiP (system-in-package). It can be easily added to an embedded system, requiring only connections to a power source, digital communication with a host, and an antenna. The package design allows it to be attached to a PCB using standard surface mount technology (SMT), with no need for additional connectors or mounting hardware. The Indy RS500 is the easiest way to embed UHF RFID reader capability.



<b>Air Interface Protocol</b>	EPCglobal UHF Class 1 Gen 2 / ISO 18000-63 (formerly 18000-6C) Supports dense reader mode (DRM)
<b>Tx Output Power</b>	+10 to +23 dBm (Peak Power)
<b>Operating Frequencies</b>	IPJ-RS500-GX (902-928MHz) supports all 900MHz bands worldwide IPJ-RS500-EU (865-868MHz) supports current EU operating band
<b>Package</b>	29 mm by 32 mm by 3.8 mm
<b>Package Type</b>	32 pin surface mount package (SMT compatible)
<b>Rx Sensitivity</b>	-65 dBm (1% packet error rate). Assumes a 15 dB antenna return loss at 23 dBm output power.
<b>DC Power Supply</b>	3.6 to 5.25 Volts
<b>Supported Regions</b>	Worldwide regional support. All major regions supported. See section 5.6 for a complete list.
<b>Compliance</b>	Certified: FCC and Canada modular operation, RoHS compliant

For technical support, visit the Impinj support portal at [support.impinj.com](http://support.impinj.com)

# 1 Table of Contents

<b>INDY® RS500 OVERVIEW .....</b>	<b>1</b>
<b>1 TABLE OF CONTENTS.....</b>	<b>2</b>
1.1 FIGURES .....	2
1.2 TABLES .....	2
<b>2 INTRODUCTION.....</b>	<b>3</b>
2.1 KEY FEATURES OF THE INDY RS500 .....	4
<b>3 SYSTEM BLOCK DIAGRAM.....</b>	<b>4</b>
<b>4 PIN LISTING AND SIGNAL DEFINITIONS.....</b>	<b>7</b>
<b>5 ELECTRICAL SPECIFICATIONS .....</b>	<b>8</b>
5.1 ABSOLUTE MAXIMUM RATINGS .....	8
5.2 OPERATING CONDITIONS.....	9
5.3 DEVICE FUNCTIONAL SPECIFICATIONS .....	9
5.4 UHF GEN 2 RFID RADIO SPECIFICATIONS.....	10
5.5 DEVICE INPUT AND OUTPUT SPECIFICATIONS .....	11
5.6 SUPPORTED REGIONS.....	13
5.7 EPC CLASS-1 GENERATION-2 OPERATION .....	15
<b>6 IMPINJ RADIO INTERFACE (IRI) .....</b>	<b>16</b>
<b>7 REGULATORY INFORMATION.....</b>	<b>17</b>
<b>8 PACKAGE AND ASSEMBLY INFORMATION.....</b>	<b>17</b>
8.1 PACKAGE MASS.....	17
8.2 PACKAGE DIMENSIONS.....	17
8.3 PCB FOOTPRINT .....	20
8.4 SMT REFLOW INFORMATION .....	24
<b>9 DOCUMENT CHANGE LOG .....</b>	<b>25</b>
<b>10 NOTICES .....</b>	<b>25</b>

## 1.1 Figures

FIGURE 2-1: RS500 SYSTEM INTEGRATION .....	4
FIGURE 3-1: EXAMPLE RS500 BLOCK DIAGRAM .....	5
FIGURE 4-1: INDY RS500 PIN LISTING.....	7
FIGURE 6-1: HOST AND READER FIRMWARE STACK .....	16
FIGURE 8-1: RS500 PACKAGE DIMENSIONS, TOP, FRONT, AND SIDE VIEWS .....	18
FIGURE 8-2: RS500 PIN DIMENSIONS (VIEWED FROM UNDERNEATH PACKAGE).....	19
FIGURE 8-3: RS500 RECOMMENDED ETCHED COPPER FOOTPRINT – ALL PADS .....	20
FIGURE 8-4: RS500 RECOMMENDED ETCHED COPPER FOOTPRINT – SINGLE PAD.....	21
FIGURE 8-5: RS500 RECOMMENDED PASTEMASK FOOTPRINT – ALL PADS .....	22
FIGURE 8-6: RS500 RECOMMENDED PASTEMASK FOOTPRINT – SINGLE PAD .....	23
FIGURE 8-7: RECOMMENDED SOLDER STENCIL OPENING WITH ETCHED PAD FOR RS500.....	23
FIGURE 8-8: RECOMMENDED SOLDER REFLOW PROFILE FOR THE INDY RS500 .....	24

## 1.2 Tables

TABLE 4-1: INDY RS500 –PIN LISTING AND SIGNAL DEFINITIONS .....	7
TABLE 5-1: INDY RS500 –ABSOLUTE MAXIMUM RATINGS.....	8
TABLE 5-2: INDY RS500 –OPERATING CONDITIONS .....	9
TABLE 5-3: INDY RS500 –SUPPLY CURRENT SPECIFICATIONS .....	9
TABLE 5-4: INDY RS500 –STARTUP AND WAKEUP TIME .....	10
TABLE 5-5: INDY RS500 –RF RECEIVER SPECIFICATIONS .....	10

TABLE 5-6: INDY RS500 – RF TRANSMITTER SPECIFICATIONS .....	10
TABLE 5-7: INDY RS500 –DIGITAL INTERFACE SPECIFICATION.....	11
TABLE 5-8: INDY RS500 –ANALOG INTERFACE SPECIFICATION.....	12
TABLE 5-9: INDY RS500 –REGIONAL SUPPORT.....	13
TABLE 5-10: INDY RS500 –LINK PROFILE.....	15
TABLE 5-11: INDY RS500 –GEN 2 FUNCTIONALITY .....	15
TABLE 5-12: INDY RS500 –INVENTORY PERFORMANCE .....	16
TABLE 8-1: RS500 SERIAL # MAKEUP.....	19
TABLE 9-1: DOCUMENT CHANGE LOG.....	25

## 2 Introduction

The Indy® RS500 reader SiP (system-in-package) is a completely integrated reader solution for EPC Gen 2 / ISO18000-63 (formerly 18000-6C) applications. The Indy RS500 was developed to make embedding UHF RFID reader capability easy. The Indy RS500 builds on market-leading Indy reader chip technology and integrates all of the necessary components into a small package. The Indy RS500 requires no external components, is fully tested and meets regulatory requirements. The Indy RS500 comes in a surface mount package designed to work as a SMT (surface mount technology) compatible component in a standard PCB manufacturing process, which eliminates costly mechanical hardware, RF cables and human assembly that are typically required with embedded readers on the market today. The Indy RS500 is a turnkey solution that will enable quick and easy embedding of RFID with low development risk and fast time-to-market.

Ideal for moderate read range of small tag populations, the Indy RS500’s small form factor enables a diverse range of applications that need a low-cost embedded UHF Gen 2 RFID reader capability, such as consumables authentication, access control, process control, appliances, POS devices for retail, medical equipment, printers, and low-duty handheld readers. The RS500 is capable of reading dozens of tags per second at distances greater than 3 meters when using a 6 dBi reader antenna and far field passive tags.

This document includes interface, functional, performance, mechanical and environmental specifications. Host communication specifications (e.g. firmware upgrade and host interface protocol) and Impinj Radio Interface (IRI) documentation is provided in the latest RS500 Software release package. The Indy RS500 uses the IRI™ (Impinj Radio Interface) to communicate with host systems. The IRI Tool Kit enables developers to build on a variety of embedded host platforms by providing the following: documentation, image loader, IRI library, sample C code and project files. The IRI Tool Kit can be found in the latest Indy RS500 Software release package and can be downloaded from the restricted documents and downloads section at [support.impinj.com](http://support.impinj.com). Please create an account and subscribe to receive automatic updates to the latest documentation and releases. Contact your local Impinj representative if you have trouble creating an account or accessing this site.

**Figure 2-1: RS500 System Integration**

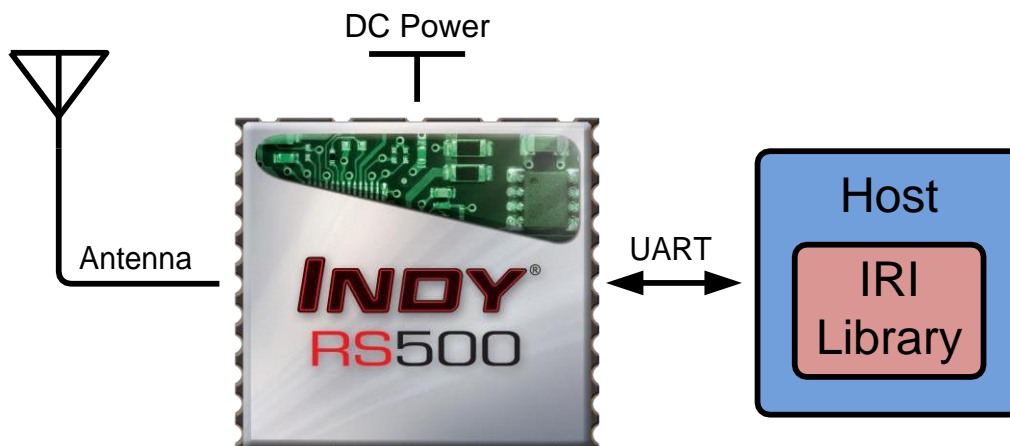

Three simple connections:

- DC Power
- UART Communication
- RF Antenna

Partners build  
API with IRI  
Tool Kit

## 2.1 Key features of the Indy RS500

- Fully tested turnkey solution
- Maximum output power is 23 dBm
- -65 dBm Rx sensitivity, assuming 15 dB antenna return loss
- Inventory (FastID, Tag Population Estimate, Select, Session, Target)
- Access (Read, Write, Lock, Kill, BlockPermalock, and QT)
- Shielded to prevent unwanted radiation and provide noise immunity in embedded environments
- 29 mm by 32 mm by 3.8 mm surface mount package with SMT compatibility
- Single mono-static RF port
- Field upgradability via firmware updates. Gen 2 v2 will be firmware upgradable.
- Part of Impinj's GrandPrix® platform, ensuring better performance when using Impinj's Monza® UHF RFID tag chips (enabling FastID, Tag Focus and QT)
- UART serial interface using IRI (Impinj Radio Interface)
- Test features (CW, PRBS, custom regions, channel lists, and fixed frequency)

## 3 System Block Diagram

An example Indy RS500 system-level block diagram for an embedded application is shown in Figure 3-1. This figure shows the electrical connections that may and must be made to control the RS500. In the figure, the required connections are illustrated with

solid lines. Recommended and optional connections are illustrated with different dotted and dashed line patterns. They are also listed below.

For more detail on pin characteristics and behaviors, see the [RS500 Hardware User's Guide](#).

**Figure 3-1: Example RS500 Block Diagram**

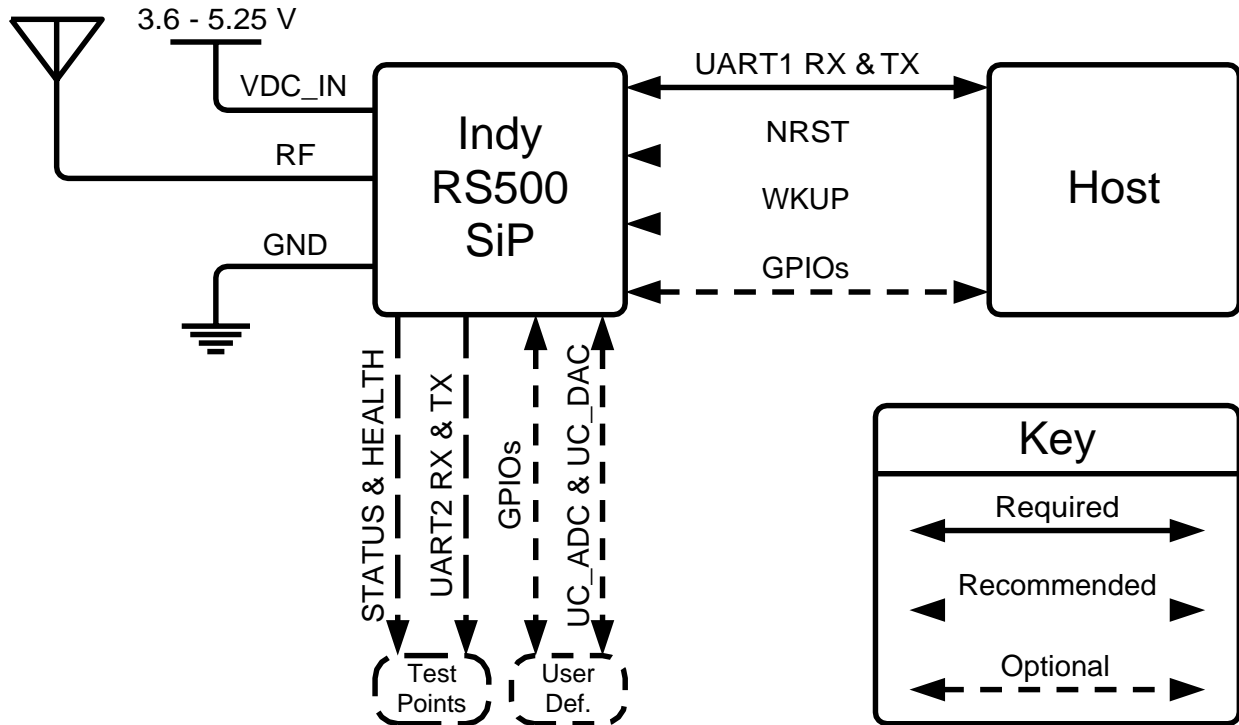

Required connections:

- VDC\_IN and GND are required to power the RS500.
- RF is required to connect to the UHF RFID antenna.
- UART1 Tx and Rx are required to communicate with the system host.

Recommended connections:

- nRST is used to reset the RS500 if UART communication is not available. This connection is highly recommended. This pin internally driven strong low during software resets, so it should only be driven externally by an open drain signal. It must not be driven strong high.
- UART2 Tx and Rx may be used to examine debug information.
- HEALTH indicates successful operation of the RS500. Connection to an LED provides a visual indication of whether or not an error condition exists.
- STATUS provides an indication when the RS500 is in active mode (for example, inventorying tags). Connection to an LED provides a visual indicator of the device's activity.

Optional connections:

- GPIOs allow interaction with the RS500 as both digital inputs and outputs. They may be used to trigger inventory, generate events based on inventory activity, or provide general-purpose user-controlled digital I/O.
- WKUP provides a mechanism to wake up the RS500 from the low power Sleep mode. WKUP is also used to force entry into the Impinj firmware bootstrap. If unused, this pin should be tied to logic low.
- UC\_ADC allows use of an ADC to convert an analog input voltage into a digital value.
- UC\_DAC allows use of a DAC to generate an analog output voltage from a digital value.
- BOOT0 provides access to the built-in bootloader in case the Impinj firmware is corrupted. For more details on the built-in bootloader, please contact Impinj support.

No connect:

- SWCLK and SWD connections are reserved for Impinj use only.

## 4 Electrical Specifications

### 4.1 Absolute Maximum Ratings

The absolute maximum ratings (see Table 5-1) define limitations for electrical and thermal stresses. These limits prevent permanent damage to the Indy RS500. Operation outside maximum ratings may result in permanent damage to the device.

**Table 5-1: Indy RS500 – Absolute Maximum Ratings**

Parameter	Min.	Max.	Unit	Conditions
Supply voltage	-0.3	5.5	V	VDC_IN pin relative to GND
IO voltage	-0.3	4.0	V	Non-VDC_IN pin voltages relative to GND
RF input power	-	+23	dBm	Incident to pin 1 (RF)
Storage temperature	-30	+100	°C	
Humidity	-	95	% RH	Non-condensing

Parameter	Min.	Max.	Unit	Conditions
ESD immunity	-	2	kV	Human-body model, all I/O pads
Package moisture sensitivity level 3	-	-	-	Indy RS500 from open trays must be baked before going through a standard solder reflow process (48 hours at 125 °C or 24hrs at 150 °C)

## 4.2 Operating Conditions

This section describes operating voltage, frequency, and temperature specifications for the Indy RS500 during operation.

**Table 5-2: Indy RS500 – Operating Conditions**

Parameter	Min.	Max.	Unit	Conditions
Supply	3.6	5.25	V	VDC_IN relative to GND
Temperature	-20	+70	°C	Ambient Temperature
Frequency	902	928	MHz	IPJ-RS500-GX, See section 5.6 for regional support
Frequency	865	868	MHz	IPJ-RS500-EU, See section 5.6 for regional support

## 4.3 Device Functional Specifications

**Table 5-3: Indy RS500 – Supply Current Specifications**

Parameter	Typ.	Unit	Description
Supply Current			Current consumed by RS500 via VDC_IN pin
Active mode - 5V supply – GX	510	mA	+23 dBm transmit power Inventorying tags
Active mode - 5V supply - EU	580	mA	+23 dBm transmit power Inventorying tags
Active mode - 3.6V supply	570	mA	+23 dBm transmit power Inventorying tags
Idle mode – low latency	50	mA	Ready to receive IRI packets. Lower latency to return to Active mode.
Idle mode – standard latency	15	mA	Ready to receive IRI packets.
Standby mode	1	mA	GPIO activity or WKUP rising edge required to wakeup part.
Sleep mode	<100	µA	WKUP rising edge required to wakeup part.



**Table 5-4: Indy RS500 – Startup and Wakeup Time**

Parameter	Min.	Typ.	Max.	Unit	Description
Startup Time		200		ms	Time to receive IRI packets after power supply or nRST pin initiated startup
Wakeup Time					Time to receive IRI packets after wakeup event
Standby		50		ms	GPIO activity or WKUP rising edge required to wakeup part.
Sleep		200		ms	WKUP rising edge required to wakeup part.

#### 4.4 UHF Gen 2 RFID Radio Specifications

**Table 5-5: Indy RS500 – RF Receiver Specifications**

Parameter	Min.	Typ.	Max.	Unit	Conditions
Frequency	902		928	MHz	IPJ-RS500-GX, See section 5.6 for regional support
Frequency	865		868	MHz	IPJ-RS500-EU, See section 5.6 for regional support
Input impedance		50		Ω	
Input match		-10		dB	S11
Rx sensitivity		-65		dBm	1% PER, assuming 15dB antenna RL at 23dBm output

**Table 5-6: Indy RS500 – RF Transmitter Specifications**

Parameter	Min.	Max.	Unit	Notes
Tx Power	10	23	dBm	Meets worldwide regulatory constraints (except Japan)
Tx Power	10	20	dBm	Meets Japan regulatory constraints
Tx Power Error				
18-23 dBm	-0.5	0.5	dB	Difference between desired Tx power and actual Tx power.
13-18 dBm	-1.0	1.0	dB	
10-13 dBm	-2.0	2.0	dB	
Tx ACPR				Refer to Gen 2 dense-interrogator transmit mask spec for definition of channel bandwidths and measurement regions.
1 <sup>st</sup> Adjacent		-25	dBch	
1 <sup>st</sup> Alternate		-55	dBch	
2 <sup>nd</sup> Alternate		-65	dBch	
Return Loss	0		dB	No damage into open RF port at 23 dBm at any phase angle
Frequency	902	928	MHz	IPJ-RS500-GX, See section 5.6 for regional support
Frequency	865	868	MHz	IPJ-RS500-EU, See section 5.6 for regional support

## 4.5 Device Input and Output Specifications

Table 5-7: Indy RS500 – Digital Interface Specification

Parameter	Min.	Typ.	Max.	Unit	Conditions
<b>nRST</b>					
V <sub>IL</sub>	-0.3		0.8	V	
V <sub>IH</sub>	2		3.6	V	
Hysteresis voltage		200		mV	
Internal pull-up resistor	25	40	55	kΩ	
Reset pulse width	25			μs	
<b>BOOT0</b>					
V <sub>IL</sub>	0.0		0.6	V	
V <sub>IH</sub>	0.62		3.6	V	
Hysteresis voltage		300		mV	
<b>WKUP</b>					
V <sub>IL</sub>	-0.3		1.0	V	
V <sub>IH</sub>	1.8		3.6	V	
Hysteresis voltage		200		mV	
Internal pull-down resistor	25	40	55	kΩ	
<b>Digital inputs</b>					
V <sub>IL</sub>	-0.3		1.0	V	
V <sub>IH</sub>	1.8		3.6	V	
Hysteresis voltage		200		mV	
Pull-up and pull-down resistor	25	40	55	kΩ	
<b>Digital outputs</b>					
V <sub>OL</sub>	0.0		0.4	V	
V <sub>OH</sub>	2.7		3.6	V	
Drive current (sink or source)	8			mA	
<b>UART</b>					
Baud rate		115.2		kbaud	
Parity		None			



**Table 5-8: Indy RS500 – Analog Interface Specification**

Parameter	Min.	Typ.	Max.	Unit	Conditions
ADC (Pin 13)					
Resolution		12		Bits	
Conversion voltage range	1		3.3	V	
Sampling rate	0.05		1	MSPs	
Total conversion time	1		18	μsec	
Power-up time			1	μsec	
External input impedance			50	kΩ	
Sampling switch resistance			1	kΩ	
Internal sample and hold capacitance			8	pF	
Total unadjusted error		±3.3	±4	LSB	
Offset error		±1.9	±2.8	LSB	
Gain error		±2.8	±3	LSB	
DNL error		±0.7	±1.3	LSB	
INL error		±1.2	±1.7	LSB	
DAC (Pin 16)					
Resolution		12		Bits	
Resistive load with buffer ON	5			kΩ	
Impedance output with buffer OFF			15	kΩ	When the buffer is OFF, the minimum resistive load between DAC_OUT and V <sub>SS</sub> to achieve 1% accuracy is 1.5 MΩ.
Capacitive load			50	pF	Maximum capacitive load at the DAC_OUT pin when the buffer is ON
Output voltage range	0.2		3.1	V	
DNL			±2	LSB	
INL			±4	LSB	
Offset			±10	mV	
Gain error			±0.5	%	
Settling time		3	4	μsec	C <sub>LOAD</sub> < 50 pF & R <sub>LOAD</sub> > 5 kΩ

## 4.6 Supported Regions

**Table 5-9: Indy RS500 – Regional Support**

<b>Region</b>	<b>SKU</b>
Argentina	IPJ-RS500-GX
Armenia	IPJ-RS500-EU
Australia (920-926 MHz)	IPJ-RS500-GX
Austria	IPJ-RS500-EU
Azerbaijan	IPJ-RS500-EU
Belgium	IPJ-RS500-EU
Bosnia and Herzegovina	IPJ-RS500-EU
Brazil (902-907 MHz)	IPJ-RS500-GX
Brazil (915-928 MHz)	IPJ-RS500-GX
Bulgaria	IPJ-RS500-EU
Canada	IPJ-RS500-GX
Chile	IPJ-RS500-GX
China (920-925 MHz)	IPJ-RS500-GX
Colombia	IPJ-RS500-GX
Costa Rica	IPJ-RS500-GX
Croatia	IPJ-RS500-EU
Cyprus	IPJ-RS500-EU
Czech Republic	IPJ-RS500-EU
Denmark	IPJ-RS500-EU
Dominican Republic	IPJ-RS500-GX
Estonia	IPJ-RS500-EU
Finland	IPJ-RS500-EU
France	IPJ-RS500-EU
Germany	IPJ-RS500-EU
Greece	IPJ-RS500-EU
Hong Kong (920-925 MHz)	IPJ-RS500-GX
Hungary	IPJ-RS500-EU
Iceland	IPJ-RS500-EU

<b>Region</b>	<b>SKU</b>
India	IPJ-RS500-EU
Indonesia	IPJ-RS500-GX
Ireland	IPJ-RS500-EU
Israel	IPJ-RS500-GX
Italy	IPJ-RS500-EU
Japan (916-921 MHz)	IPJ-RS500-GX
Korea (917-921 MHz)	IPJ-RS500-GX
Latvia	IPJ-RS500-EU
Lithuania	IPJ-RS500-EU
Luxembourg	IPJ-RS500-EU
Macedonia	IPJ-RS500-EU
Malaysia (919-923 MHz)	IPJ-RS500-GX
Malta	IPJ-RS500-EU
Mexico	IPJ-RS500-GX
Moldova	IPJ-RS500-EU
Netherlands	IPJ-RS500-EU
New Zealand (921-928 MHz)	IPJ-RS500-GX
Norway	IPJ-RS500-EU
Oman	IPJ-RS500-EU
Panama	IPJ-RS500-GX
Peru	IPJ-RS500-GX
Philippines	IPJ-RS500-GX
Poland	IPJ-RS500-EU
Portugal	IPJ-RS500-EU
Romania	IPJ-RS500-EU
Russian Federation (916-921 MHz)	IPJ-RS500-GX
Saudi Arabia	IPJ-RS500-EU
Serbia	IPJ-RS500-EU
Singapore (920-925 MHz)	IPJ-RS500-GX
Slovak Republic	IPJ-RS500-EU

Region	SKU
Slovenia	IPJ-RS500-EU
South Africa (915-919 MHz)	IPJ-RS500-GX
Spain	IPJ-RS500-EU
Sweden	IPJ-RS500-EU
Switzerland	IPJ-RS500-EU
Taiwan (922-928 MHz)	IPJ-RS500-GX
Thailand	IPJ-RS500-GX
Turkey	IPJ-RS500-EU
United Arab Emirates	IPJ-RS500-EU
United Kingdom	IPJ-RS500-EU
United States	IPJ-RS500-GX
Uruguay	IPJ-RS500-GX
Venezuela	IPJ-RS500-GX
Vietnam (920-925 MHz)	IPJ-RS500-GX

## 4.7 EPC Class-1 Generation-2 Operation

**Table 5-10: Indy RS500 – Link Profile**

Parameter	Description
Forward Link	PR-ASK
	25 $\mu$ s Tari
Reverse Link	250 kHz link frequency
	Miller, M=4
	62.5 kbps data rate

**Table 5-11: Indy RS500 – Gen 2 Functionality**

Parameter	Description
Select	Support for 2 Select commands
Inventory	FastID, TagFocus, Tag Population Estimate, Select, Session, and Target
Access	Read, Write, Lock, Kill, BlockPermalock, and QT

**Table 5-12: Indy RS500 – Inventory Performance**

Parameter	Min.	Typ.	Max.	Unit	Conditions
Inventory Rate		130		Tags/sec	1 Tag with tag population estimate = 1
		35		Tags/sec	1 Tag with tag population estimate = 16
		50		Tags/sec	16 Tags with tag population estimate = 16

## 5 Impinj Radio Interface (IRI)

The Indy RS500 uses IRI to enable communications; this is enabled with the IRI Tool Kit. The IRI Tool Kit includes documentation, IRI API, and sample C code. The IRI Tool Kit is intended to enable a broad set of host platforms due to its ease of use and portability.

Communication with the RS500 via IRI occurs in two states:

1. Configuration (synchronous)
  - a. All communications are commands and responses
  - b. Start and Stop commands cause transition to the Listen state
2. Listen (asynchronous)
  - a. Host is in a listening mode and polls to obtain tag reports

Customer applications can be enabled on a variety of embedded systems with hosts ranging in size from small microcontrollers to large microprocessors. The IRI Tool Kit is structured to ease portability by separating platform specific code from functional reader operation; this is illustrated in Figure 6-1 below.

**Figure 6-1: Host and Reader Firmware Stack**

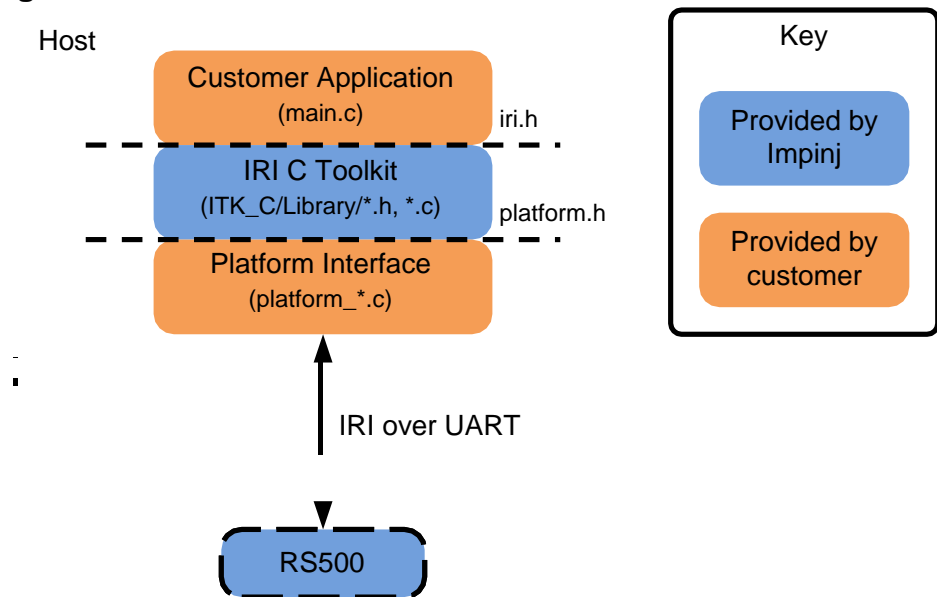



Please refer to the documentation included in the RS500 release package for complete details on communicating with the Indy RS500 using IRI. The latest Indy RS500 release package, which includes the IRI Tool Kit, can be downloaded at [support.impinj.com](http://support.impinj.com).

## 6 Regulatory Information

The Indy RS500 (IPJ-RS500) has been certified for modular operation by FCC and Industry Canada in certain specific configurations. Use of these IDs requires specific text be added to product labeling and product Hardware User's Guides. See the [Indy RS500 Hardware User's Guide](#) for more details on labeling specifics.

## 7 Package and Assembly Information

This section provides mechanical drawings and critical dimensions needed for PCB layout and housing design, as well as SMT assembly information.

### 7.1 Package Mass

The mass of the RS500 SiP is 4.6 grams.

### 7.2 Package Dimensions

Package dimensions are shown in Figure 8-1 and Figure 8-2.

All dimensions are in millimeters.

Dimension tolerances (unless otherwise specified):

X = 1.0

X.X = 0.5

X.XX = 0.25

X.XXX = 0.125

Hole = 0.075

Angular: MACH 0.5

Bend: 1.0 Degree

**Table 8-1: RS500 Serial # Makeup**

Digits	Meaning
XX	SKU code: 01 = GX 02 = EU
ZZ	Lot number
WW	Workweek produced
YY	Year produced
AAAA	Serial number within the lot

**Figure 8-2: RS500 Pin Dimensions (viewed from underneath package)**

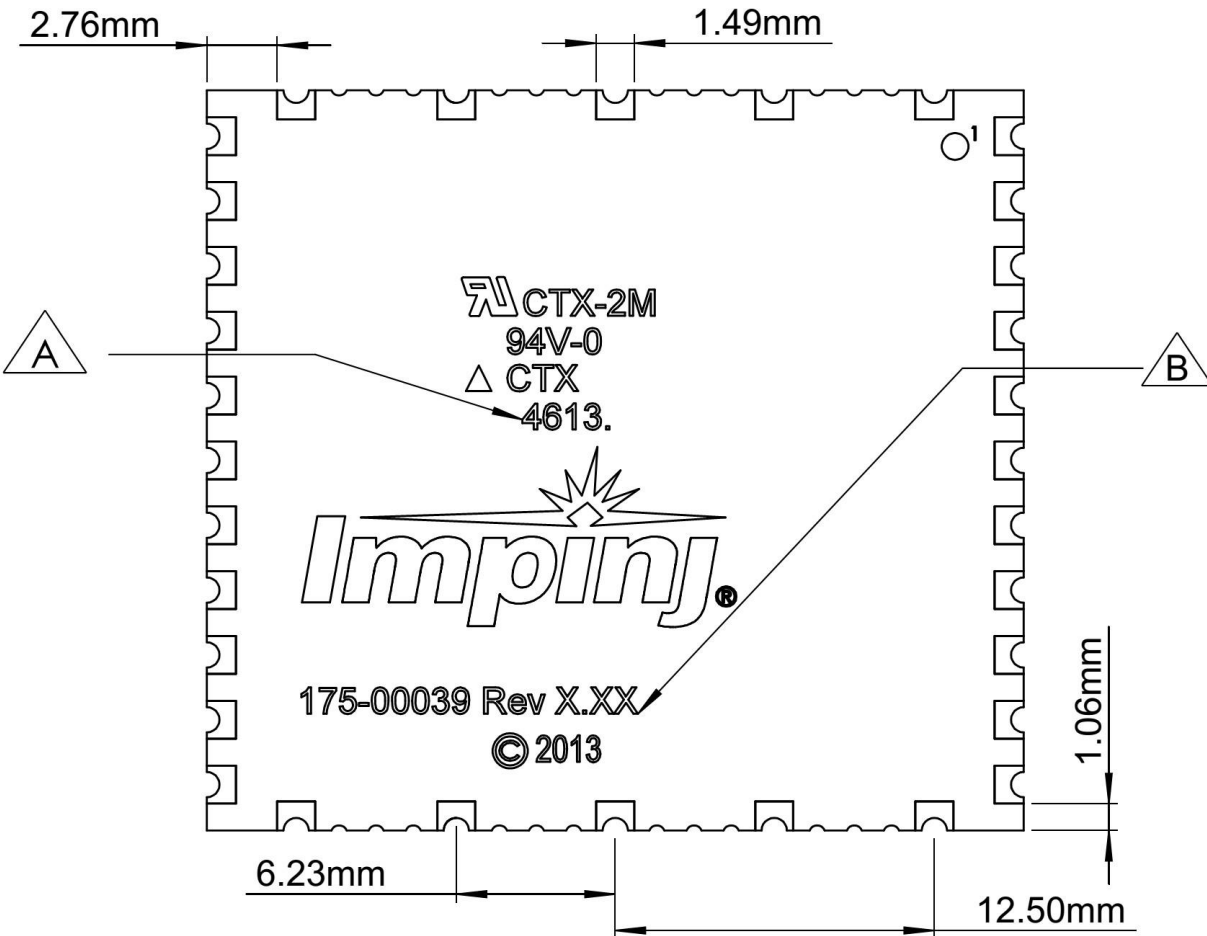

**Note.** Callouts A and B show package markings that will vary depending on the manufacturing lot of the RS500 unit.

### 7.3 PCB Footprint

Recommended footprint copper and pastemask dimensions are shown in Figure 8-3 and Figure 8-5. Dimensions for the individual pads are shown in Figure 8-4 and Figure 8-6.

**Figure 8-3: RS500 Recommended Etched Copper Footprint – All Pads**

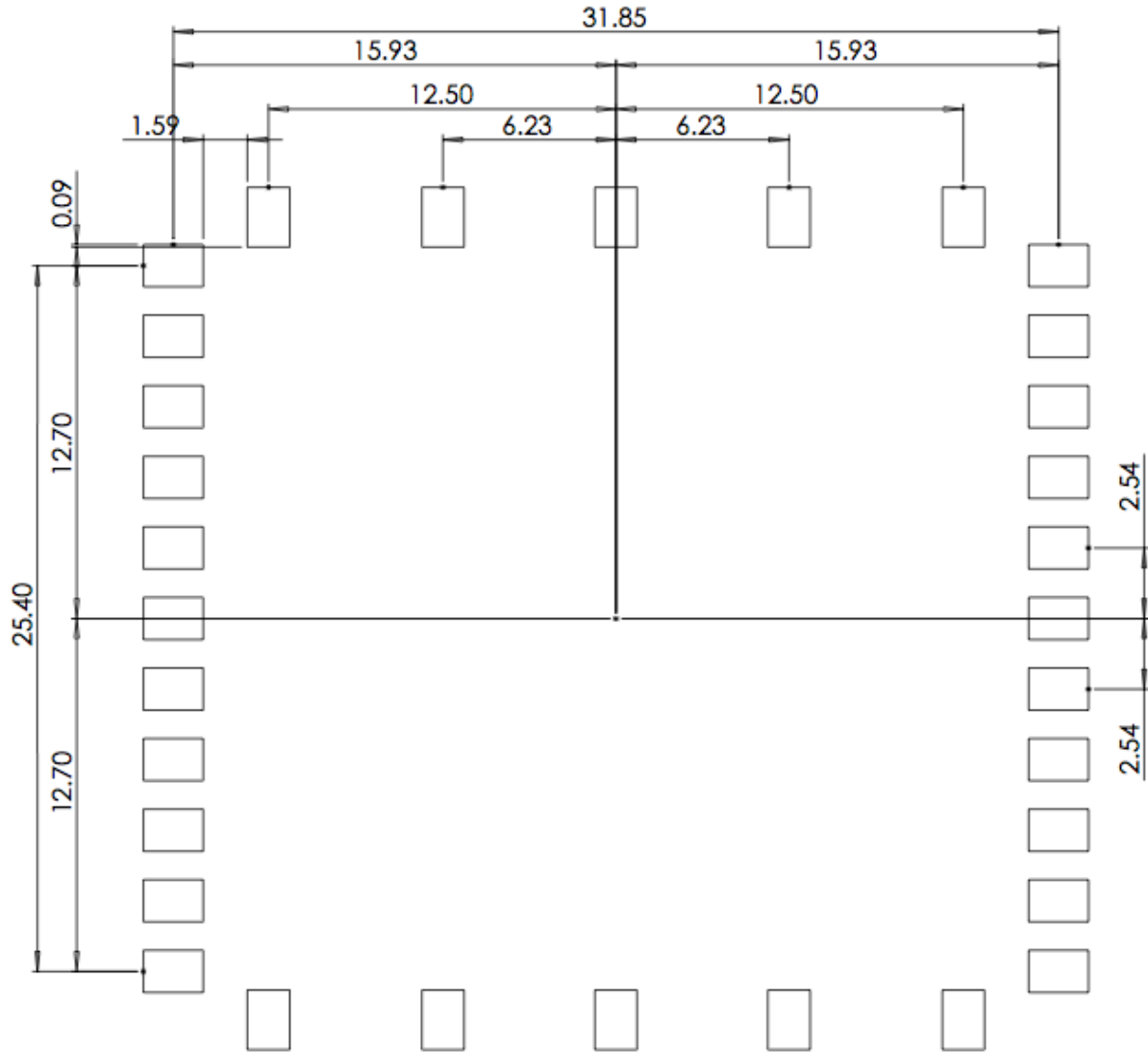

**Figure 8-4: RS500 Recommended Etched Copper Footprint – Single Pad**

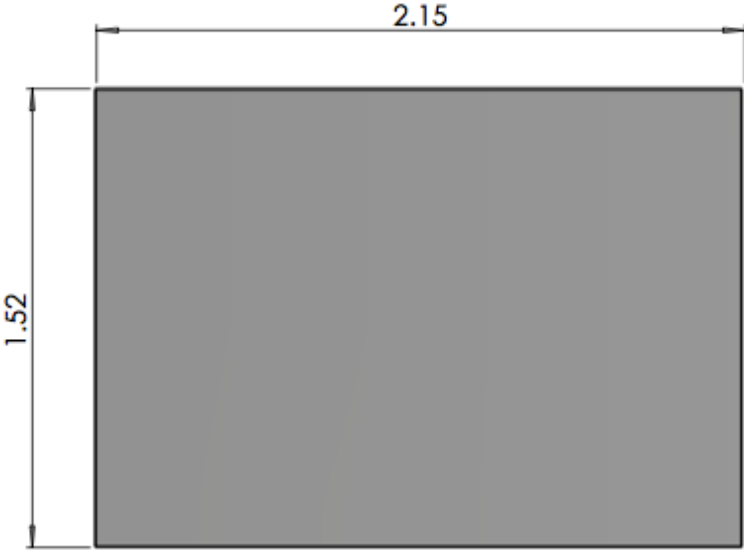
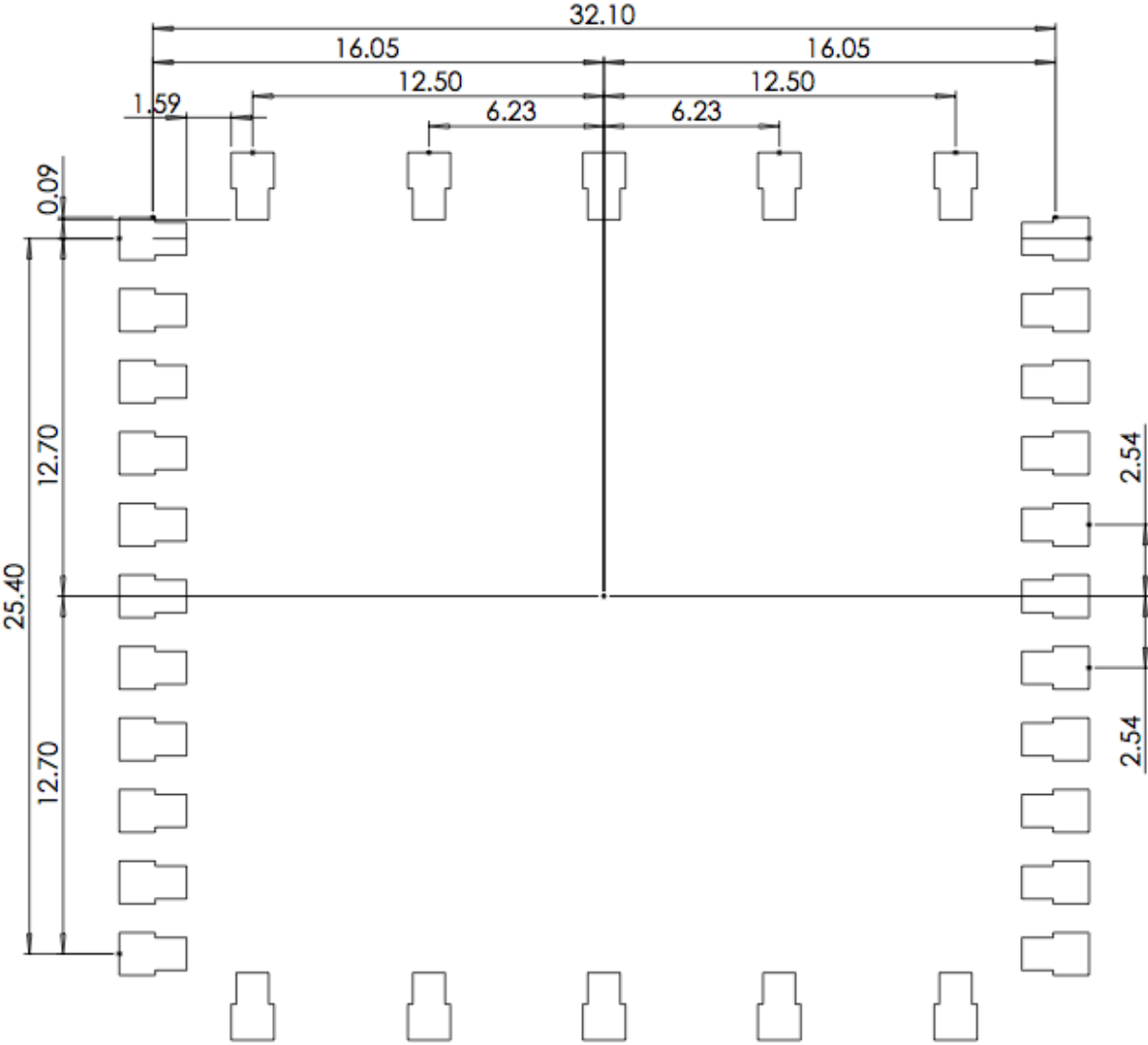
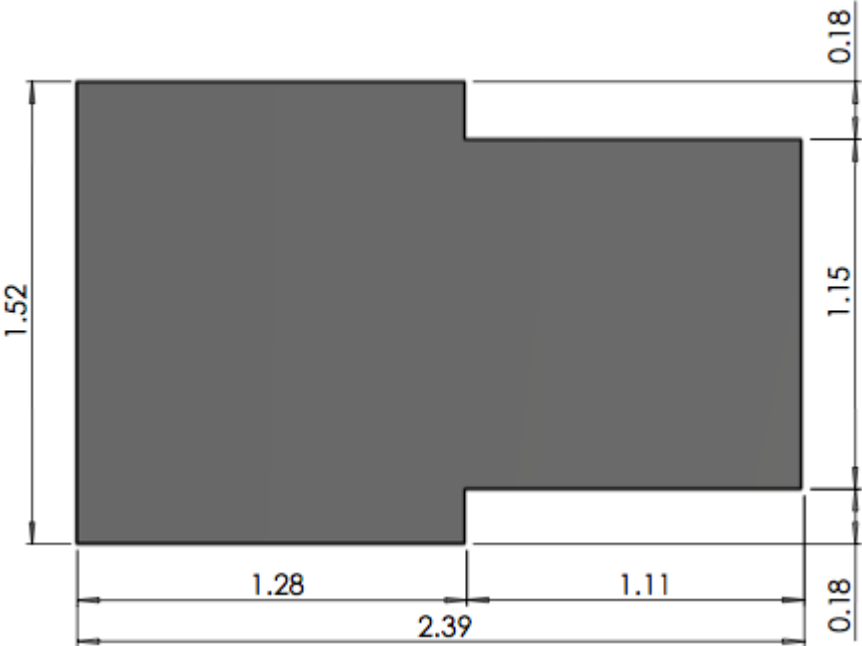

Figure 8-5: RS500 Recommended Pastemask Footprint – All Pads

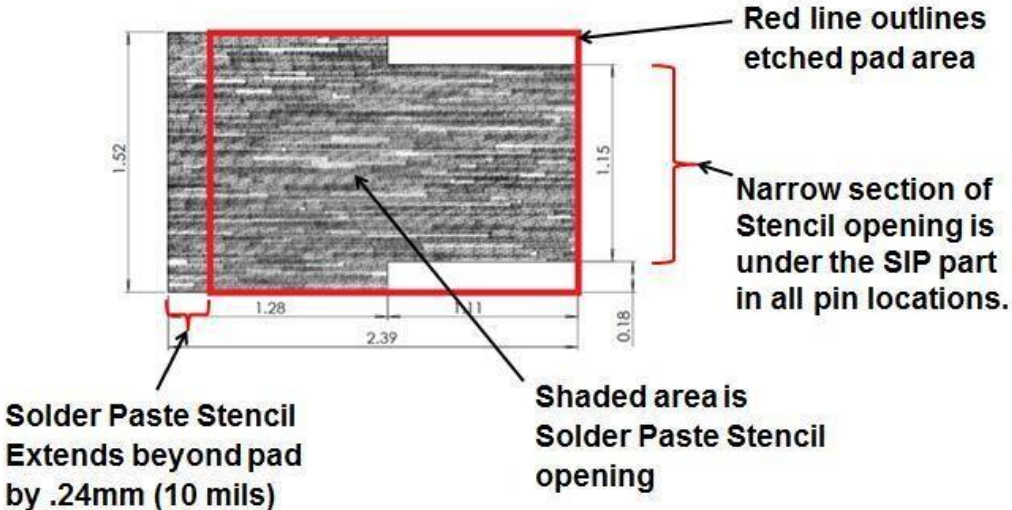

**Figure 8-6: RS500 Recommended Pastemask Footprint – Single Pad**



It is important to note that the optimal pad and stencil design results in a stencil aperture that is of a different shape than and that overhangs the etched pad. This design delivers the optimum amount of solder to the castellation of the SiP pad. Figure 8-7 depicts the pad/solder relationship.

**Figure 8-7: Recommended Solder Stencil Opening with Etched Pad for RS500**



## 7.4 SMT Reflow Information

No-clean Type 3 Sn3Ag0.5Cu Solder Paste (Koki S3X58- M650) was used during Impinj's testing of the Indy RS500. The solder manufacturer's recommended reflow profile is shown in Figure 8-8.

**Figure 8-8: Recommended Solder Reflow Profile for the Indy RS500**

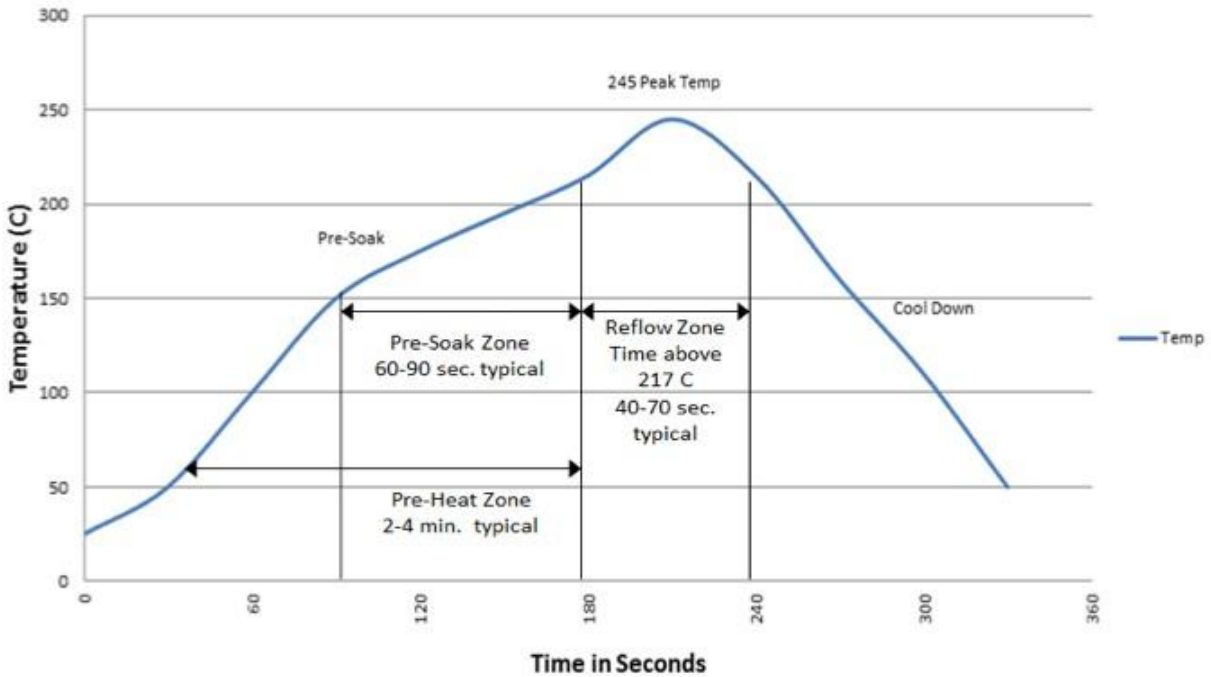

## 8 Document Change Log

Table 9-1: Document Change Log

Version	Date	Description
1.0		Initial version
1.1	4/30/2014	Package drawings updated Spec clarifications Regulatory information moved to Hardware User's Guide Formatting updates Change log added

## 9 Notices

Copyright © 2014, Impinj, Inc. All rights reserved.

Impinj gives no representation or warranty, express or implied, for accuracy or reliability of information in this document. Impinj reserves the right to change its products and services and this information at any time without notice.

EXCEPT AS PROVIDED IN IMPINJ'S TERMS AND CONDITIONS OF SALE (OR AS OTHERWISE AGREED IN A VALID WRITTEN INDIVIDUAL AGREEMENT WITH IMPINJ), IMPINJ ASSUMES NO LIABILITY WHATSOEVER AND IMPINJ DISCLAIMS ANY EXPRESS OR IMPLIED WARRANTY, RELATED TO SALE AND/OR USE OF IMPINJ PRODUCTS INCLUDING LIABILITY OR WARRANTIES RELATING TO FITNESS FOR A PARTICULAR PURPOSE, MERCHANTABILITY, OR INFRINGEMENT.

NO LICENSE, EXPRESS OR IMPLIED, BY ESTOPPEL OR OTHERWISE, TO ANY PATENT, COPYRIGHT, MASK WORK RIGHT, OR OTHER INTELLECTUAL PROPERTY RIGHT IS GRANTED BY THIS DOCUMENT.

Impinj assumes no liability for applications assistance or customer product design. Customers should provide adequate design and operating safeguards to minimize risks.

Impinj products are not designed, warranted or authorized for use in any product or application where a malfunction may reasonably be expected to cause personal injury or death or property or environmental damage ("hazardous uses") or for use in automotive environments. Customers must indemnify Impinj against any damages arising out of the use of Impinj products in any hazardous or automotive uses.

Indy is a trademark of Impinj, Inc. All other product or service names are trademarks of their respective companies.

[www.impinj.com](http://www.impinj.com)



## **Federal Communication Commission Interference Statement**

This device complies with Part 15 of the FCC Rules. Operation is subject to the following two conditions: (1) This device may not cause harmful interference, and (2) this device must accept any interference received, including interference that may cause undesired operation.

This equipment has been tested and found to comply with the limits for a Class B digital device, pursuant to Part 15 of the FCC Rules. These limits are designed to provide reasonable protection against harmful interference in a residential installation. This equipment generates, uses and can radiate radio frequency energy and, if not installed and used in accordance with the instructions, may cause harmful interference to radio communications. However, there is no guarantee that interference will not occur in a particular installation. If this equipment does cause harmful interference to radio or television reception, which can be determined by turning the equipment off and on, the user is encouraged to try to correct the interference by one of the following measures:

- Reorient or relocate the receiving antenna.
- Increase the separation between the equipment and receiver.
- Connect the equipment into an outlet on a circuit different from that to which the receiver is connected.
- Consult the dealer or an experienced radio/TV technician for help.

### **FCC Caution:**

- Any changes or modifications not expressly approved by the party responsible for compliance could void the user's authority to operate this equipment.
- This transmitter must not be co-located or operating in conjunction with any other antenna or transmitter.

**Radiation Exposure Statement:**

This equipment complies with FCC radiation exposure limits set forth for an uncontrolled environment. This module can be used with **T800** or similar platform with similar dimension, antenna location and RF characteristic.

**This device is intended only for OEM integrators under the following conditions:**

- 1) The antenna must be installed at the same location as tested in the certification filing, and the maximum antenna gain allowed for use with this device is **4.41** dBi.
- 2) The transmitter module may not be co-located with any other transmitter or antenna.
- 3) For portable usage condition, this module has been SAR evaluated in **T800** host with compliance result and can be used with this specific host as described in the certification filing. Other host or platform needs separate approval.

As long as 3 conditions above are met, further transmitter test will not be required.

However, the OEM integrator is still responsible for testing their end-product for any additional compliance requirements required with this module installed

**IMPORTANT NOTE:** In the event that these conditions can not be met (for example certain laptop configurations or co-location with another transmitter), then the FCC authorization is no longer considered valid and the FCC ID can not be used on the final product. In these circumstances, the OEM integrator will be responsible for re-evaluating the end product (including the transmitter) and obtaining a separate FCC authorization.

**End Product Labeling**

The final end product must be labeled in a visible area with the following: “**Contains FCC ID: QYLRS500**”. The grantee's FCC ID can be used only when all FCC compliance requirements are met.

**Manual Information To the End User**

The OEM integrator has to be aware not to provide information to the end user regarding how to install or remove this RF module in the user's manual of the end product which integrates this module. The end user manual shall include all required regulatory information/warning as show in this manual.