

# FCC Radio Test Report

## FCC ID: QYLRC7611B41

**Report No.** : BTL-FCCP-4-2202T096  
**Equipment** : Body Worn Camera  
**Model Name** : BC-4K  
**Brand Name** : Getac  
**Applicant** : Getac Technology Corporation  
**Address** : 5F., Building A, No.209, Sec.1, Nangang., Rd., Nangang Dist., Taipei City 11568, Taiwan, R.O.C.

**Radio Function** : LTE Band 14

**FCC Rule Part(s)** : FCC CFR Title 47, Part 2, 90(R)  
**Measurement Procedure(s)** : ANSI C63.26-2015  
ANSI/TIA-603-E-2016  
FCC KDB 971168 D01 Power Meas License Digital Systems v03r01

**Date of Receipt** : 2022/3/23  
**Date of Test** : 2022/8/2 ~ 2022/9/5  
**Issued Date** : 2022/10/26

The above equipment has been tested and found in compliance with the requirement of the above standards by BTL Inc.

**Prepared by** : Eric Lee  
Eric Lee, Engineer

**Approved by** : Jerry Chuang  
Jerry Chuang, Supervisor

**BTL Inc.**

No.18, Ln. 171, Sec. 2, Jiuzong Rd., Neihu Dist., Taipei City 114, Taiwan

Tel: +886-2-2657-3299

Fax: +886-2-2657-3331

Web: www.newbtl.com

**Declaration**

**BTL** represents to the client that testing is done in accordance with standard procedures as applicable and that test instruments used has been calibrated with standards traceable to international standard(s) and/or national standard(s).

**BTL's** reports apply only to the specific samples tested under conditions. It is manufacture's responsibility to ensure that additional production units of this model are manufactured with the identical electrical and mechanical components. **BTL** shall have no liability for any declarations, inferences or generalizations drawn by the client or others from **BTL** issued reports.

This report is the confidential property of the client. As a mutual protection to the clients, the public and ourselves, the test report shall not be reproduced, except in full, without our written approval.

**BTL's** laboratory quality assurance procedures are in compliance with the **ISO/IEC 17025** requirements, and accredited by the conformity assessment authorities listed in this test report.

**BTL** is not responsible for the sampling stage, so the results only apply to the sample as received.

The information, data and test plan are provided by manufacturer which may affect the validity of results, so it is manufacturer's responsibility to ensure that the apparatus meets the essential requirements of applied standards and in all the possible configurations as representative of its intended use.

**Limitation**

For the use of the authority's logo is limited unless the Test Standard(s)/Scope(s)/Item(s) mentioned in this test report is (are) included in the conformity assessment authorities acceptance respective.

Please note that the measurement uncertainty is provided for informational purpose only and are not use in determining the Pass/Fail results.

**CONTENTS**

1	SUMMARY OF TEST RESULTS	5
1.1	TEST FACILITY	6
1.2	MEASUREMENT UNCERTAINTY	6
1.3	TEST ENVIRONMENT CONDITIONS	6
2	GENERAL INFORMATION	7
2.1	DESCRIPTION OF EUT	7
2.2	TEST MODES	8
2.3	BLOCK DIAGRAM SHOWING THE CONFIGURATION OF SYSTEM TESTED	9
2.4	SUPPORT UNITS	10
3	AC POWER LINE CONDUCTED EMISSIONS TEST	11
3.1	LIMIT	11
3.2	TEST PROCEDURE	11
3.3	DEVIATION FROM TEST STANDARD	11
3.4	TEST SETUP	12
3.5	TEST RESULT	12
4	EFFECTIVE RADIATED POWER MEASUREMENT	13
4.1	LIMIT	13
4.2	TEST PROCEDURE	13
4.3	DEVIATION FROM TEST STANDARD	13
4.4	TEST SETUP	14
4.5	EUT OPERATING CONDITIONS	14
4.6	TEST RESULT	14
5	RADIATED SPURIOUS EMISSIONS MEASUREMENT	15
5.1	LIMIT	15
5.2	TEST PROCEDURE	15
5.3	DEVIATION FROM TEST STANDARD	15
5.4	TEST SETUP	16
5.5	EUT OPERATING CONDITIONS	16
5.6	TEST RESULT	16
6	LIST OF MEASURING EQUIPMENTS	17
7	EUT TEST PHOTO	18
8	EUT PHOTOS	18
APPENDIX A	AC POWER LINE CONDUCTED EMISSIONS	19
APPENDIX B	EFFECTIVE RADIATED POWER	24
APPENDIX C	RADIATED SPURIOUS EMISSIONS	29

**REVISION HISTORY**

Report No.	Version	Description	Issued Date	Note
BTL-FCCP-4-2202T096	R00	Original Report.	2022/10/3	Invalid
BTL-FCCP-4-2202T096	R01	Revised report to address TCB's comments.	2022/10/26	Valid

# 1 SUMMARY OF TEST RESULTS

Test procedures according to the technical standards.

Standard(s) Section	Description	Test Result	Judgement	Remark
15.207	AC Power Line Conducted Emissions	APPENDIX A	Pass	-----
2.1046 90.542 (a)(7)	Conducted Output Power Effective Radiated Power	APPENDIX B	Pass	NOTE (5)
-	Peak To Average Ratio	NOTE (3)	Pass	-----
2.1049	Occupied Bandwidth	NOTE (3)	Pass	-----
2.1053 90.543 (e)(2)(3)	Band Edge Measurements	NOTE (3)	Pass	-----
2.1051 90.210(n)	Mask Measurements	NOTE (3)	Pass	-----
2.1053 90.543 (e)(3)	Conducted Spurious Emissions	NOTE (3)	Pass	-----
2.1055 90.539 (e)	Frequency Stability Temperature & Voltage	NOTE (3)	Pass	-----
2.1053 90.543 (e)(3) 90.543 (f)	Radiated Spurious Emissions	APPENDIX C	Pass	-----

**NOTE:**

- (1) "N/A" denotes test is not applicable in this Test Report.
- (2) The report format version is TP.1.1.1.
- (3) This is to request a Class II permissive change for FCC ID: QYLRC7611B41 (This FCC ID is change ID based on Sierra Wireless Inc., the original application information follow as model: RC7611, FCC ID: N7NRC76B, approved on 02/05/2020)  
 Since the RF module has been certificated, after evaluation, above test items were criticized and reconfirmed in this report, for other test data can be refer report No.: 19B0422R-HPUSP50V00.
- (4) The ac power lines conducted emissions, output power and radiated emissions are tested to demonstrate full compliance of both module integrated into the host and host itself.
- (5) Due to the slight difference between each measurement, some of the new measured power values are larger than the original Module Report, but still within the tolerance range.

### 1.1 TEST FACILITY

The test facilities used to collect the test data in this report:

No. 72, Ln. 169, Sec. 2, Datong Rd., Xizhi Dist., New Taipei City 221, Taiwan

The test sites and facilities are covered under FCC RN: 674415 and DN: TW0659.

C06       CB21       CB22

No. 68-1, Ln. 169, Sec. 2, Datong Rd., Xizhi Dist., New Taipei City 221, Taiwan

The test sites and facilities are covered under FCC RN: 674415 and DN: TW0659.

C05       CB08       CB11       CB15       CB16  
 SR05

### 1.2 MEASUREMENT UNCERTAINTY

The reported uncertainty of measurement  $y \pm U$ , where expanded uncertainty  $U$  is based on a standard uncertainty multiplied by a coverage factor of  $k = 2$ , providing a level of confidence of approximately **95 %**. The measurement instrumentation uncertainty considerations contained in CISPR 16-4-2. The BTL measurement uncertainty is less than the CISPR 16-4-2  $U_{cispr}$  requirement.

A. AC power line conducted emissions test:

Test Site	Method	Measurement Frequency Range	U (dB)
C05	CISPR	150 kHz ~ 30MHz	3.44

B. Effective Radiated Power and Radiated emissions test :

Test Site	Measurement Frequency Range	U,(dB)
CB21	0.03 GHz ~ 0.2 GHz	4.17
	0.2 GHz ~ 1 GHz	4.72
	1 GHz ~ 6 GHz	5.21
	6 GHz ~ 18 GHz	5.51
	18 GHz ~ 26 GHz	3.69
	26 GHz ~ 40 GHz	4.23

NOTE:

Unless specifically mentioned, the uncertainty of measurement has not been taken into account to declare the compliance or non-compliance to the specification.

### 1.3 TEST ENVIRONMENT CONDITIONS

Test Item	Environment Condition	Test Voltage	Tested by
AC Power Line Conducted Emissions	22 °C, 50 %	AC 120V	Jay Tien
Conducted Output Power	24.3 °C, 61 %	AC 120V	Angela Wang
Effective Radiated Power	Refer to data	AC 120V	Mark Wang
Radiated Spurious Emissions	Refer to data	AC 120V	Mark Wang

## 2 GENERAL INFORMATION

### 2.1 DESCRIPTION OF EUT

Equipment	Body Worn Camera		
Model Name	BC-4K		
Brand Name	Getac		
Model Difference	N/A		
Power Source	(1) From host system or power adapter. (2) Battery supplied.		
Power Rating	(1)		
	BC-4K	Cable type	Input Voltage
	Pogo pins	Magnetic USB type A to pogo Cable	5V /1.5A
	USB type C	Type C To C cable	5V/3A and 9V/2.2A
	(2) Getac / BP1S1P5000P: Rated Voltage: 3.63 Vdc Rated capacity: 4750 mAh, 17.24 Wh Typical capacity: 5000 mAh, 18.15 Wh		
Products Covered	1 * Adjustable Pocket Mount 1 * Clip Mount 1 * Magnetic Mount 1 * Molle Mount 1 * Dual Magnetic Mount		
WWAN Module	AirPrime / RC7611		
Operation Frequency	Band	UL Frequency (MHz)	DL Frequency (MHz)
	LTE 14	788 ~ 798	758 ~ 768
Maximum ERP	Band	BW (MHz)	Mode
	LTE 14	5	QPSK
			16QAM
	LTE 14	10	QPSK
16QAM			
Test Model	BC-4K		
Sample Status	Engineering Sample		
EUT Modification(s)	N/A		

**NOTE:**

(1) The above EUT information is declared by manufacturer and for more detailed features description, please refers to the manufacturer's specifications or user's manual.

(2) Table for Filed Antenna:

Antenna	Brand Name	Model Name	Type	Connector	Gain (dBi)	Note
Main	Getac	BC-4K	Loop	N/A	-0.63	LTE Band 14
Aux	Getac	BC-4K	Loop	N/A	-	RX only

**2.2 TEST MODES**

Test Items	Band	Test Mode	Note
AC Power Line Conducted Emissions	-	Normal/Idle	-
Conducted Output Power	LTE Band 14	Refer to APPENDIX B	-
Effective Radiated Power	LTE Band 14	TX Mode (CH 23330)	-
Radiated Spurious Emissions	LTE Band 14	TX Mode (CH 23330)	-

**NOTE:**

- (1) All X, Y and Z axes are evaluated, but only the worst case (Y axis) is recorded.
- (2) For Radiated Spurious Emissions both QPSK and 16QAM are evaluated, but only the worst case (QPSK) is recorded.



**2.3 BLOCK DIAGRAM SHOWING THE CONFIGURATION OF SYSTEM TESTED**

Equipment letters and Cable numbers refer to item numbers described in the tables of clause 2.4.

AC Power Line Conducted Emissions Test

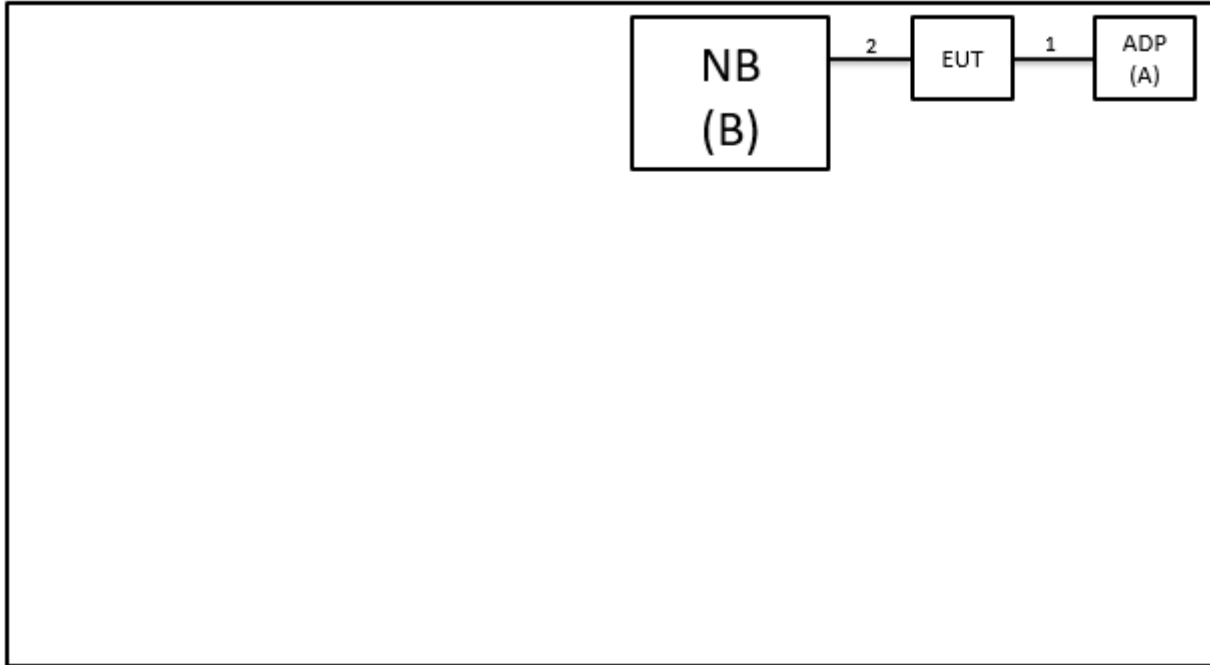

Radiated Emissions Test

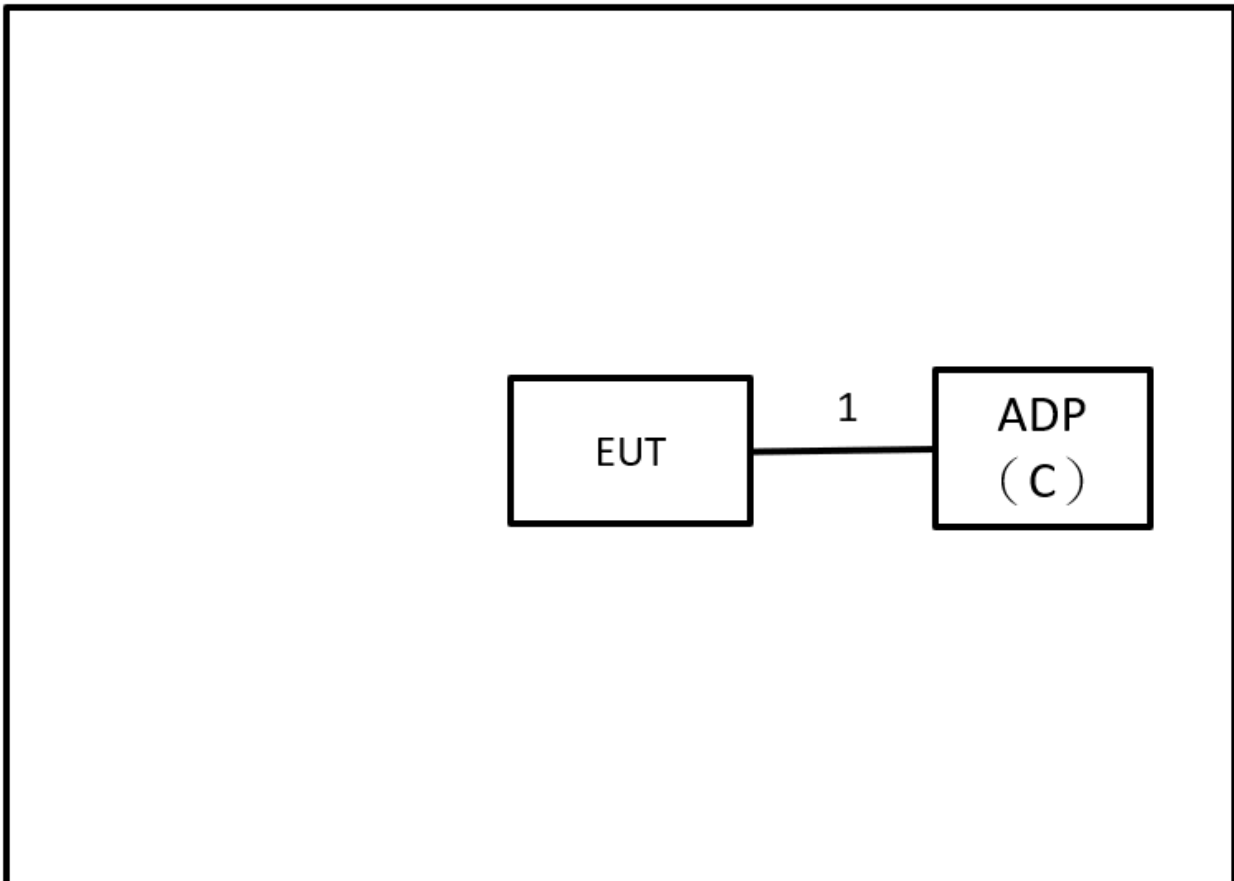

**2.4 SUPPORT UNITS**

Item	Equipment	Brand	Model No.	Series No.	Remarks
A	Adapter	SONY	AC-0051-TW	4017W29100317	Furnished by test lab.
B	NB	ASUS	X555LN-0021B4 210U	N/A	Furnished by test lab.
C	Adapter	SAMSUNG	EP-TA12JWS	N/A	Furnished by test lab.

Item	Shielded	Ferrite Core	Length	Cable Type	Remarks
1	N/A	N/A	1m	Magnetic USB typeA to pogo Cable	Supplied by test requester.
2	N/A	N/A	1.2m	USB Cable	Furnished by test lab.

### 3 AC POWER LINE CONDUCTED EMISSIONS TEST

#### 3.1 LIMIT

Frequency (MHz)	Limit (dB $\mu$ V)	
	Quasi-peak	Average
0.15 - 0.5	66 - 56 *	56 - 46 *
0.50 - 5.0	56	46
5.0 - 30.0	60	50

**NOTE:**

- (1) The tighter limit applies at the band edges.
- (2) The limit of " \* " marked band means the limitation decreases linearly with the logarithm of the frequency in the range.
- (3) The test result calculated as following:  
 Measurement Value = Reading Level + Correct Factor  
 Correct Factor = Insertion Loss + Cable Loss + Attenuator Factor (if use)  
 Margin Level = Measurement Value – Limit Value  
 Calculation example:

Reading Level		Correct Factor		Measurement Value
38.22	+	3.45	=	41.67

Measurement Value		Limit Value		Margin Level
41.67	-	60	=	-18.33

The following table is the setting of the receiver.

Receiver Parameter	Setting
Attenuation	10 dB
Start Frequency	0.15 MHz
Stop Frequency	30 MHz
IF Bandwidth	9 KHz

#### 3.2 TEST PROCEDURE

- a. The EUT was placed 0.8 m above the horizontal ground plane with the EUT being connected to the power mains through a line impedance stabilization network (LISN).  
 All other support equipment were powered from an additional LISN(s).  
 The LISN provides 50 Ohm/50uH of impedance for the measuring instrument.
- b. Interconnecting cables that hang closer than 40 cm to the ground plane shall be folded back and forth in the center forming a bundle to keep the cable above 40 cm.
- c. Excess I/O cables that are not connected to a peripheral shall be bundled in the center.  
 The end of the cable will be terminated, using the correct terminating impedance.  
 The overall length shall not exceed 1 m.
- d. The LISN is spaced at least 80 cm from the nearest part of the EUT chassis.
- e. For the actual test configuration, please refer to the related Item - EUT TEST PHOTO.

**NOTE:**

- (1) In the results, each reading is marked as Peak, QP or AVG per the detector used.  
 BW=9 kHz (6 dB Bandwidth)
- (2) All readings are Peak unless otherwise stated QP or AVG in column of Note. Both the QP and the AVG readings must be less than the limit for compliance.

#### 3.3 DEVIATION FROM TEST STANDARD

No deviation.

### 3.4 TEST SETUP

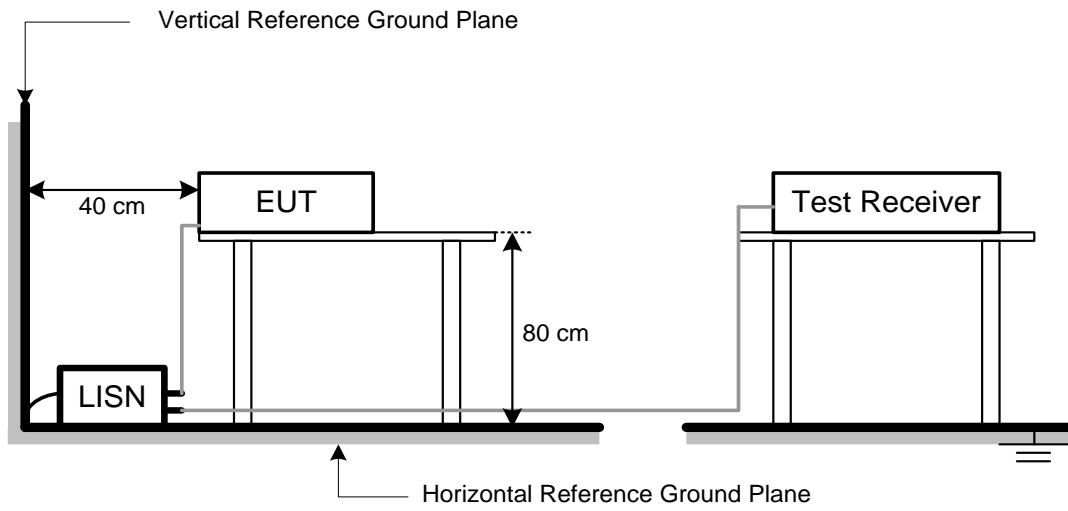

### 3.5 TEST RESULT

Please refer to the APPENDIX A.

## 4 EFFECTIVE RADIATED POWER MEASUREMENT

### 4.1 LIMIT

Mobile / Portable station are limited to 3 watts e.r.p.

NOTE:

(1) The test result calculated as following:

Measurement Value = Reading Level + Correct Factor

Correct Factor = Antenna Factor + Cable Loss - Amplifier Gain(if use)

Margin Level = Measurement Value - Limit Value

Calculation example:

Reading Level		Correct Factor		Measurement Value
-29.66	+	34.26	=	4.60

Measurement Value		Limit Value		Margin Level
4.60	-	38.45	=	-33.85

### 4.2 TEST PROCEDURE

The testing follows FCC KDB 971168 v03r01 Section 5.8.

- a. Substitution method is used for E.I.R.P measurement. In the semi-anechoic chamber, EUT placed on the 0.8m height of Turn Table, rotated the table around 360 degrees to search the maximum radiation power and receiver antenna shall be rotated vertical and horizontal polarization and moved height from 1m to 4m to find the maximum polar radiated power. The "Read Value" is the spectrum reading the maximum power value.
- b. The substitution horn antenna is substituted for EUT at the same position and signals generator export the CW signal to the substitution antenna via a TX cable. Rotated the Turn Table and moved receiving antenna to find the maximum radiation power. Adjust output power level of S.G to get a Value of spectrum reading equal to "Read Value " of step a. Record the power level of S.G
- c. EIRP = Output power level of S.G – TX cable loss + Antenna gain of substitution horn.
- d. ERP can be calculated form EIRP by subtracting the gain of dipole,  $ERP = EIPR - 2.15dBi.$
- e. The resolution bandwidth and video bandwidth of test receiver/spectrum analyzer is 1MHz/3MHz.

### 4.3 DEVIATION FROM TEST STANDARD

No deviation.

#### 4.4 TEST SETUP

##### Conducted Measurement:

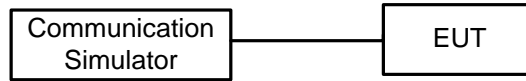

##### Radiated Measurement:

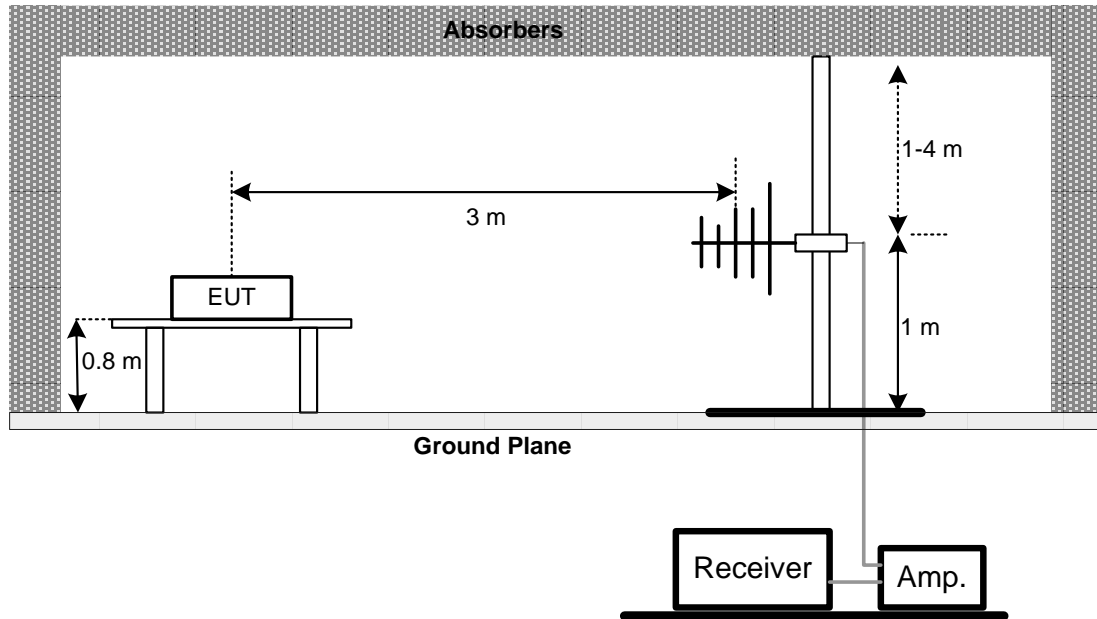

#### 4.5 EUT OPERATING CONDITIONS

The EUT was programmed to be in continuously transmitting mode.

#### 4.6 TEST RESULT

Please refer to the APPENDIX B.

## 5 RADIATED SPURIOUS EMISSIONS MEASUREMENT

### 5.1 LIMIT

The power of any emission outside of the authorized operating frequency ranges must be attenuated below the transmitting power (P) by a factor of at least  $43 + 10 \log(P)$  dB. The emission limit equal to -13dBm.

NOTE:

- (1) The measurements of emission power can be expressed in peak or average values, provided they are expressed in the same parameters as the transmitter power.
- (2) The test result calculated as following:

Measurement Value = Reading Level + Correct Factor  
 Correct Factor = Antenna Factor + Cable Loss - Amplifier Gain(if use)  
 Margin Level = Measurement Value - Limit Value

Calculation example:

Reading Level		Correct Factor		Measurement Value
-50.43	+	-2.11	=	-52.54

Measurement Value		Limit Value		Margin Level
-52.54	-	-13	=	-39.54

### 5.2 TEST PROCEDURE

The testing follows FCC KDB 971168 v03r01 Section 6.2.

- a. Substitution method is used for E.I.R.P measurement. In the semi-anechoic chamber, EUT placed on the 0.8m height of Turn Table, rotated the table around 360 degrees to search the maximum radiation power and receiver antenna shall be rotated vertical and horizontal polarization and moved height from 1m to 4m to find the maximum polar radiated power. The "Read Value" is the spectrum reading the maximum power value.
- b. The substitution horn antenna is substituted for EUT at the same position and signals generator export the CW signal to the substitution antenna via a TX cable. Rotated the Turn Table and moved receiving antenna to find the maximum radiation power. Adjust output power level of S.G to get a Value of spectrum reading equal to "Read Value " of step a. Record the power level of S.G
- c. EIRP = Output power level of S.G – TX cable loss + Antenna gain of substitution horn.
- d. ERP can be calculated form EIRP by subtracting the gain of dipole,  $ERP = EIPR - 2.15\text{dBi}$ .
- e. The resolution bandwidth and video bandwidth of test receiver/spectrum analyzer is 1MHz/3MHz.

### 5.3 DEVIATION FROM TEST STANDARD

No deviation.

## 5.4 TEST SETUP

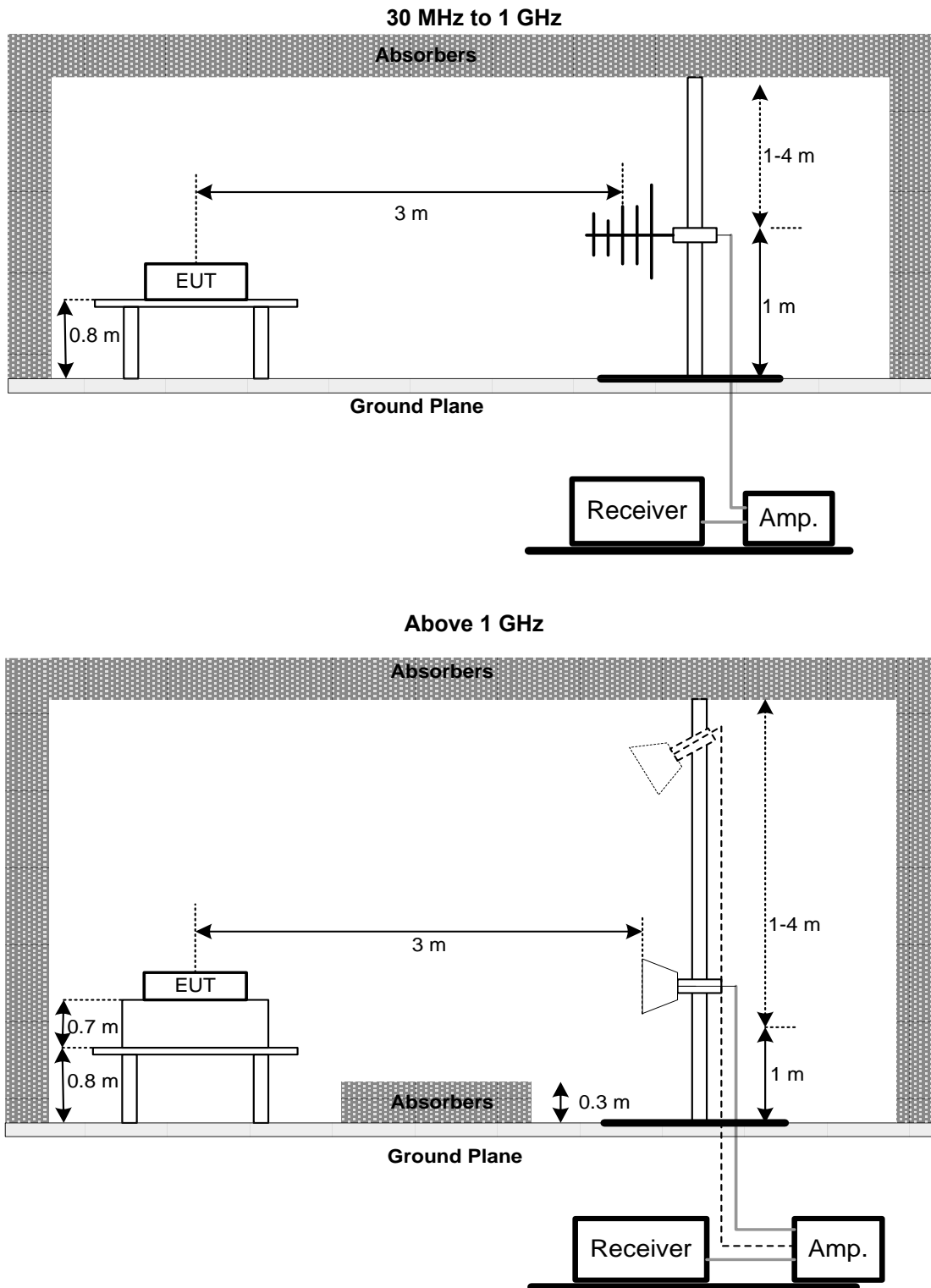

## 5.5 EUT OPERATING CONDITIONS

The EUT was programmed to be in continuously transmitting mode.

## 5.6 TEST RESULT

Please refer to the APPENDIX C.



## 6 LIST OF MEASURING EQUIPMENTS

AC Power Line Conducted Emissions						
Item	Kind of Equipment	Manufacturer	Type No.	Serial No.	Calibrated Date	Calibrated Until
1	TWO-LINE V-NETWORK	R&S	ENV216	101051	2022/6/15	2023/6/14
2	Test Cable	EMCI	EMCRG58-BM-B M-9000	210501	2022/5/2	2023/5/1
3	EMI Test Receiver	R&S	ESR 7	101433	2021/11/24	2022/11/23
4	Measurement Software	EZ	EZ EMC (Version NB-03A1-01)	N/A	N/A	N/A

Conducted Output Power						
Item	Kind of Equipment	Manufacturer	Type No.	Serial No.	Calibrated Date	Calibrated Until
1	Radio Communication Analyzer	Anritsu	MT8820C	6201381608	2021/12/15	2022/12/14

Effective Radiated Power and Radiated Emissions						
Item	Kind of Equipment	Manufacturer	Type No.	Serial No.	Calibrated Date	Calibrated Until
1	Preamplifier	EMCI	EMC330N	980850	2021/9/23	2022/9/22
2	Preamplifier	EMCI	EMC118A45SE	980819	2022/3/8	2023/3/7
3	Preamplifier	EMCI	EMC001340	980555	2022/4/6	2023/4/5
4	Test Cable	EMCI	EMC104-SM-SM-1000	220319	2022/3/15	2023/3/14
5	Test Cable	EMCI	EMC104-SM-SM-3000	220322	2022/3/15	2023/3/14
6	Test Cable	EMCI	EMC104-SM-SM-7000	220324	2022/3/15	2023/3/14
7	EXA Signal Analyzer	keysight	N9020A	MY57120120	2022/3/7	2023/3/6
8	Loop Ant	Electro-Metrics	EMCI-LPA600	274	2022/6/28	2023/6/27
9	Horn Antenna	RFSPIN	DRH18-E	211202A18EN	2022/5/18	2023/5/17
10	Horn Ant	Schwarzbeck	BBHA 9170D	1136	2022/5/18	2023/5/17
11	Log-bicon Antenna	Schwarzbeck	VULB9168	1369	2022/5/20	2023/5/19
12	6dB Attenuator	EMCI	EMCI-N-6-06	AT-N0625	2022/5/20	2023/5/19
13	Measurement Software	EZ	EZ EMC (Version NB-03A1-01)	N/A	N/A	N/A
14	Radio Communication Analyzer (LTE)	Anritsu	MT8820C	6201381608	2021/12/15	2022/12/14

Remark: "N/A" denotes no model name, no serial no. or no calibration specified.  
All calibration period of equipment list is one year.

## **7 EUT TEST PHOTO**

Please refer to document Appendix No.: TP-2202T096-FCCP-1 (APPENDIX-TEST PHOTOS).

## **8 EUT PHOTOS**

Please refer to document Appendix No.: EP-2202T096-2 (APPENDIX-EUT PHOTOS).

## **APPENDIX A AC POWER LINE CONDUCTED EMISSIONS**

Test Mode	Normal	Tested Date	2022/8/5
Test Frequency	-	Phase	Line

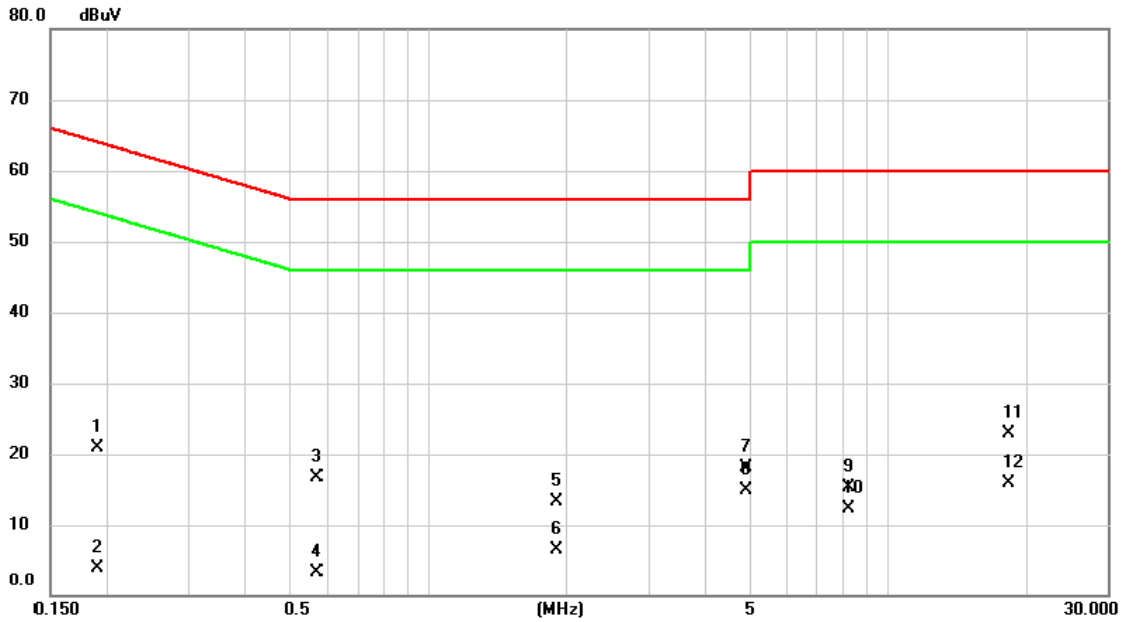

No.	Mk.	Freq. MHz	Reading Level dBuV	Correct Factor dB	Measure- ment dBuV	Limit dBuV	Margin dB	Detector	Comment
1		0.1905	11.25	9.63	20.88	64.01	-43.13	QP	
2		0.1905	-5.65	9.63	3.98	54.01	-50.03	AVG	
3		0.5714	7.15	9.62	16.77	56.00	-39.23	QP	
4		0.5714	-6.23	9.62	3.39	46.00	-42.61	AVG	
5		1.8957	3.54	9.69	13.23	56.00	-42.77	QP	
6		1.8957	-3.12	9.69	6.57	46.00	-39.43	AVG	
7		4.8945	8.41	9.75	18.16	56.00	-37.84	QP	
8	*	4.8945	5.21	9.75	14.96	46.00	-31.04	AVG	
9		8.2165	5.44	9.82	15.26	60.00	-44.74	QP	
10		8.2165	2.53	9.82	12.35	50.00	-37.65	AVG	
11		18.1755	13.08	9.82	22.90	60.00	-37.10	QP	
12		18.1755	6.12	9.82	15.94	50.00	-34.06	AVG	

**REMARKS:**

- (1) Measurement Value = Reading Level + Correct Factor.
- (2) Margin Level = Measurement Value - Limit Value.

Test Mode	Normal	Tested Date	2022/8/5
Test Frequency	-	Phase	Neutral

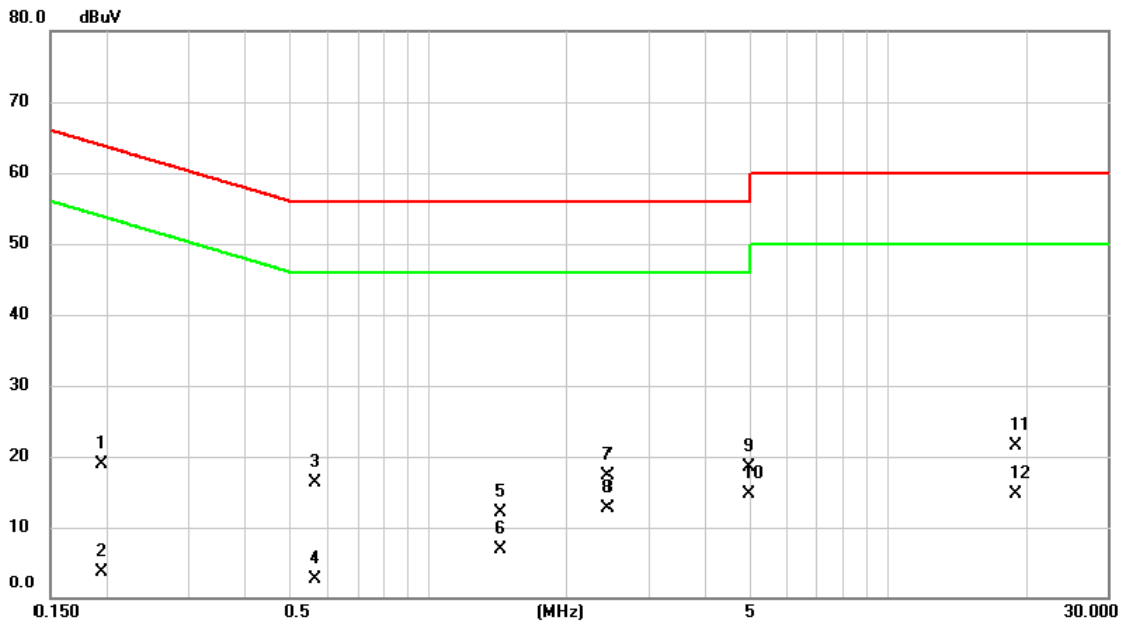

No. Mk.	Freq. MHz	Reading Level dBuV	Correct Factor dB	Measurement dBuV	Limit dBuV	Margin dB	Detector	Comment
1	0.1945	9.35	9.62	18.97	63.84	-44.87	QP	
2	0.1945	-5.84	9.62	3.78	53.84	-50.06	AVG	
3	0.5670	6.77	9.62	16.39	56.00	-39.61	QP	
4	0.5670	-6.98	9.62	2.64	46.00	-43.36	AVG	
5	1.4380	2.35	9.67	12.02	56.00	-43.98	QP	
6	1.4380	-2.84	9.67	6.83	46.00	-39.17	AVG	
7	2.4438	7.54	9.70	17.24	56.00	-38.76	QP	
8	2.4438	3.02	9.70	12.72	46.00	-33.28	AVG	
9	4.9537	8.65	9.76	18.41	56.00	-37.59	QP	
10 *	4.9537	4.88	9.76	14.64	46.00	-31.36	AVG	
11	18.9453	11.63	9.94	21.57	60.00	-38.43	QP	
12	18.9453	4.72	9.94	14.66	50.00	-35.34	AVG	

**REMARKS:**

- (1) Measurement Value = Reading Level + Correct Factor.
- (2) Margin Level = Measurement Value - Limit Value.

Test Mode	Idle	Tested Date	2022/8/5
Test Frequency	-	Phase	Line

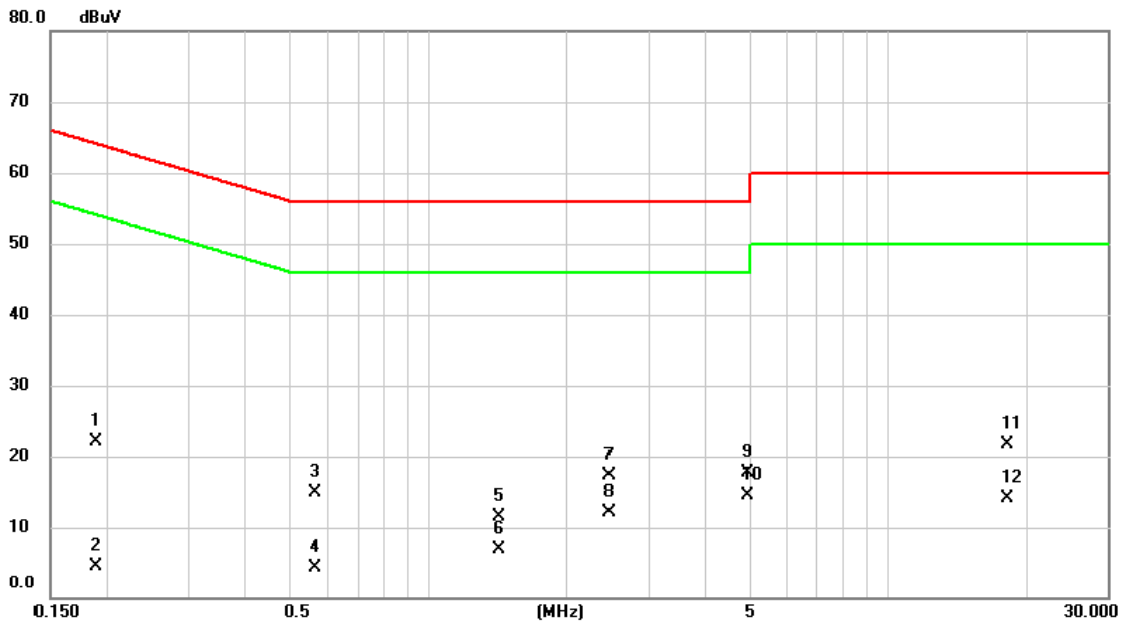

No. Mk.	Freq. MHz	Reading Level dBuV	Correct Factor dB	Measurement dBuV	Limit dBuV	Margin dB	Detector	Comment
1	0.1883	12.44	9.63	22.07	64.11	-42.04	QP	
2	0.1883	-5.12	9.63	4.51	54.11	-49.60	AVG	
3	0.5662	5.26	9.62	14.88	56.00	-41.12	QP	
4	0.5662	-5.34	9.62	4.28	46.00	-41.72	AVG	
5	1.4235	1.84	9.67	11.51	56.00	-44.49	QP	
6	1.4235	-2.84	9.67	6.83	46.00	-39.17	AVG	
7	2.4653	7.52	9.70	17.22	56.00	-38.78	QP	
8	2.4653	2.45	9.70	12.15	46.00	-33.85	AVG	
9	4.9290	7.98	9.75	17.73	56.00	-38.27	QP	
10 *	4.9290	4.84	9.75	14.59	46.00	-31.41	AVG	
11	18.1613	11.89	9.82	21.71	60.00	-38.29	QP	
12	18.1613	4.23	9.82	14.05	50.00	-35.95	AVG	

**REMARKS:**

- (1) Measurement Value = Reading Level + Correct Factor.
- (2) Margin Level = Measurement Value - Limit Value.

Test Mode	Idle	Tested Date	2022/8/5
Test Frequency	-	Phase	Neutral

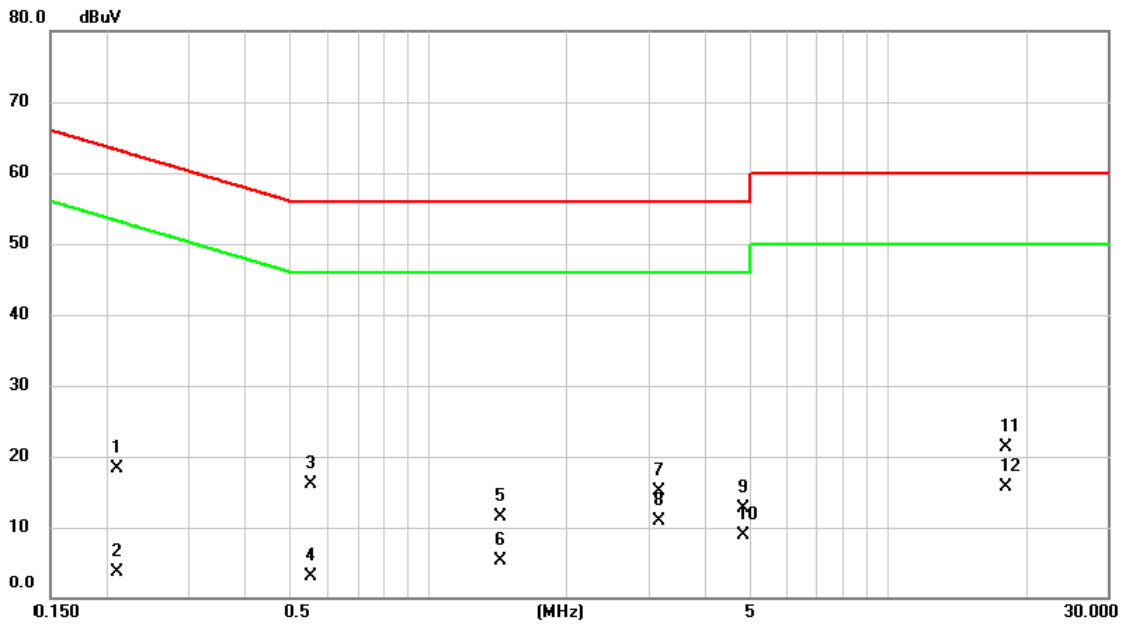

No.	Mk.	Freq. MHz	Reading Level dBuV	Correct Factor dB	Measure- ment dBuV	Limit dBuV	Margin dB	Detector	Comment
1		0.2100	8.75	9.62	18.37	63.21	-44.84	QP	
2		0.2100	-5.84	9.62	3.78	53.21	-49.43	AVG	
3		0.5571	6.54	9.62	16.16	56.00	-39.84	QP	
4		0.5571	-6.52	9.62	3.10	46.00	-42.90	AVG	
5		1.4351	1.84	9.67	11.51	56.00	-44.49	QP	
6		1.4351	-4.33	9.67	5.34	46.00	-40.66	AVG	
7		3.1540	5.41	9.73	15.14	56.00	-40.86	QP	
8		3.1540	1.23	9.73	10.96	46.00	-35.04	AVG	
9		4.8432	2.99	9.76	12.75	56.00	-43.25	QP	
10		4.8432	-0.95	9.76	8.81	46.00	-37.19	AVG	
11		18.0244	11.32	9.92	21.24	60.00	-38.76	QP	
12	*	18.0244	5.88	9.92	15.80	50.00	-34.20	AVG	

**REMARKS:**

- (1) Measurement Value = Reading Level + Correct Factor.
- (2) Margin Level = Measurement Value - Limit Value.

## APPENDIX B EFFECTIVE RADIATED POWER



**Conducted Output Power and Calculated ERP:**
**LTE Band 14 Power:**

Band	BW (MHz)	Channel	Frequency (MHz)	Mode	UL RB Allocation	UL RB Offset	MPR	Average power (dBm)	ERP power (dBm)	ERP power (W)
14	5	23305	790.5	QPSK	1	0	0	23.10	20.32	0.108
					1	12	0	23.38	20.60	0.115
					1	24	0	23.25	20.47	0.111
					12	0	1	22.21	19.43	0.088
					12	6	1	22.54	19.76	0.095
				12	11	1	22.40	19.62	0.092	
				25	0	1	22.24	19.46	0.088	
				1	0	1	22.20	19.42	0.087	
				1	12	1	22.48	19.70	0.093	
				1	24	1	22.36	19.58	0.091	
				12	0	2	21.29	18.51	0.071	
				12	6	2	21.48	18.70	0.074	
				12	11	2	21.44	18.66	0.073	
				25	0	2	21.41	18.63	0.073	
				1	0	0	23.13	20.35	0.108	
		1	12	0	23.41	20.63	0.115			
		1	24	0	23.29	20.51	0.112			
		12	0	1	22.25	19.47	0.088			
		12	6	1	22.57	19.79	0.095			
		12	11	1	22.43	19.65	0.092			
		25	0	1	22.25	19.47	0.088			
		1	0	1	22.23	19.45	0.088			
		1	12	1	22.51	19.73	0.094			
		1	24	1	22.40	19.62	0.092			
		12	0	2	21.34	18.56	0.072			
		12	6	2	21.52	18.74	0.075			
		12	11	2	21.47	18.69	0.074			
		25	0	2	21.44	18.66	0.073			
		1	0	0	23.12	20.34	0.108			
		1	12	0	23.39	20.61	0.115			
		1	24	0	23.27	20.49	0.112			
		12	0	1	22.23	19.45	0.088			
		12	6	1	22.55	19.77	0.095			
		12	11	1	22.41	19.63	0.092			
		25	0	1	22.23	19.45	0.088			
		1	0	1	22.21	19.43	0.088			
		1	12	1	22.49	19.71	0.094			
		1	24	1	22.38	19.60	0.091			
		12	0	2	21.32	18.54	0.071			
		12	6	2	21.50	18.72	0.075			
		12	11	2	21.45	18.67	0.074			
		25	0	2	21.42	18.64	0.073			
		1	0	0	23.12	20.34	0.108			
		1	12	0	23.39	20.61	0.115			
		1	24	0	23.27	20.49	0.112			
12	0	1	22.23	19.45	0.088					
12	6	1	22.55	19.77	0.095					
12	11	1	22.41	19.63	0.092					
25	0	1	22.23	19.45	0.088					
1	0	1	22.21	19.43	0.088					
1	12	1	22.49	19.71	0.094					
1	24	1	22.38	19.60	0.091					
12	0	2	21.32	18.54	0.071					
12	6	2	21.50	18.72	0.075					
12	11	2	21.45	18.67	0.074					
25	0	2	21.42	18.64	0.073					

**NOTE:**

- (1) EIRP = Average power + Antenna gain.
- (2) ERP = EIRP - 2.15.
- (3) P(W) =  $1 \text{ W} \cdot 10^{(P(\text{dBm}) / 10) / 1000}$

Band	BW (MHz)	Channel	Frequency (MHz)	Mode	UL RB Allocation	UL RB Offset	MPR	Average power (dBm)	ERP power (dBm)	ERP power (W)
14	10	23330	793.0	QPSK	1	0	0	<b>23.17</b>	20.39	0.109
					1	24	0	<b>23.44</b>	20.66	0.116
					1	49	0	<b>23.32</b>	20.54	0.113
					25	0	1	22.28	19.50	0.089
					25	12	1	22.60	19.82	0.096
					25	24	1	22.46	19.68	0.093
				16QAM	50	0	1	22.28	19.50	0.089
					1	0	1	22.26	19.48	0.089
					1	24	1	22.54	19.76	0.095
					1	49	1	22.43	19.65	0.092
					25	0	2	21.37	18.59	0.072
					25	12	2	21.55	18.77	0.075
					25	24	2	21.50	18.72	0.074
					50	0	2	21.47	18.69	0.074

**NOTE:**

- (1) EIRP = Average power + Antenna gain.
- (2) ERP = EIRP - 2.15.
- (3)  $P(W) = 1 W \cdot 10^{(P(dBm) / 10)} / 1000$

**Radiated ERP Power:**

Test Mode	LTE Band 14	Test Date	2022/8/30
Test Channel	CH23330	Polarization	Vertical
Temp	25°C	Hum.	60%

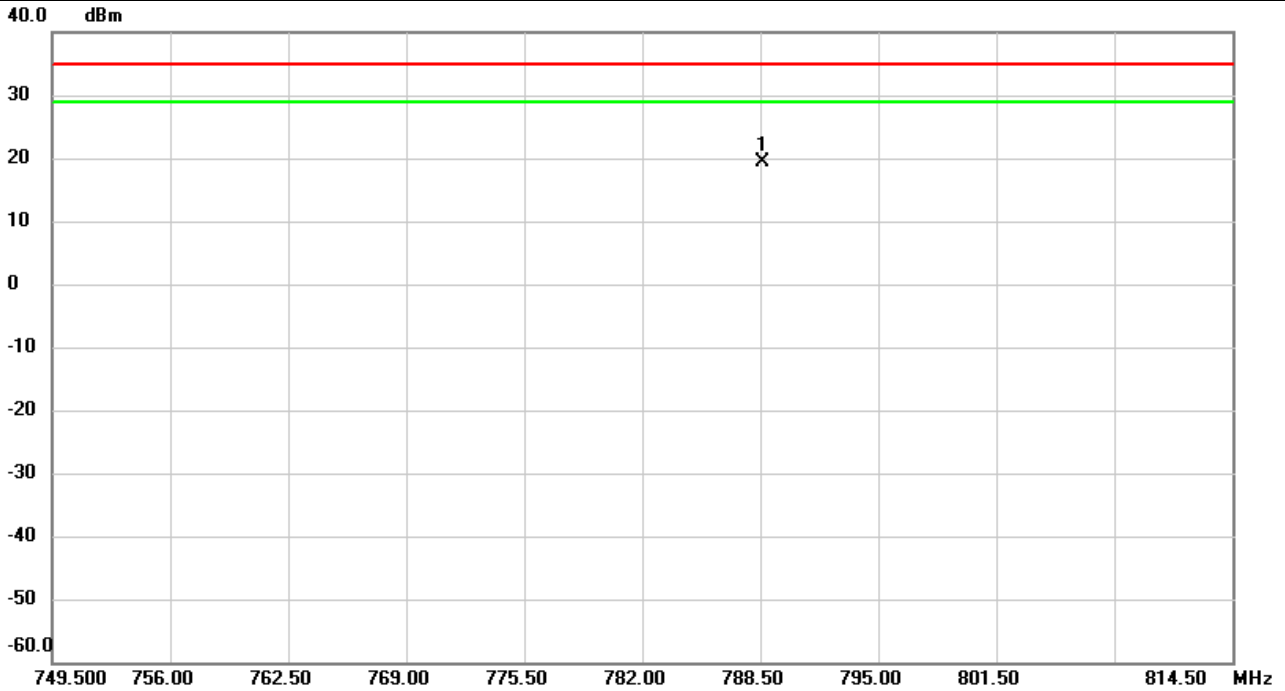

No.	Mk.	Freq.	Reading Level	Correct Factor	Measurement	Limit	Over	Detector	Comment
		MHz	dBm	dB	dBm	dBm	dB		
1	*	788.6408	9.57	9.69	19.26	34.77	-15.51	peak	

**REMARKS:**

- (1) Measurement Value = Reading Level + Correct Factor.
- (2) Margin Level = Measurement Value - Limit Value.

Test Mode	LTE Band 14	Test Date	2022/8/30
Test Channel	CH23330	Polarization	Horizontal
Temp	25°C	Hum.	60%

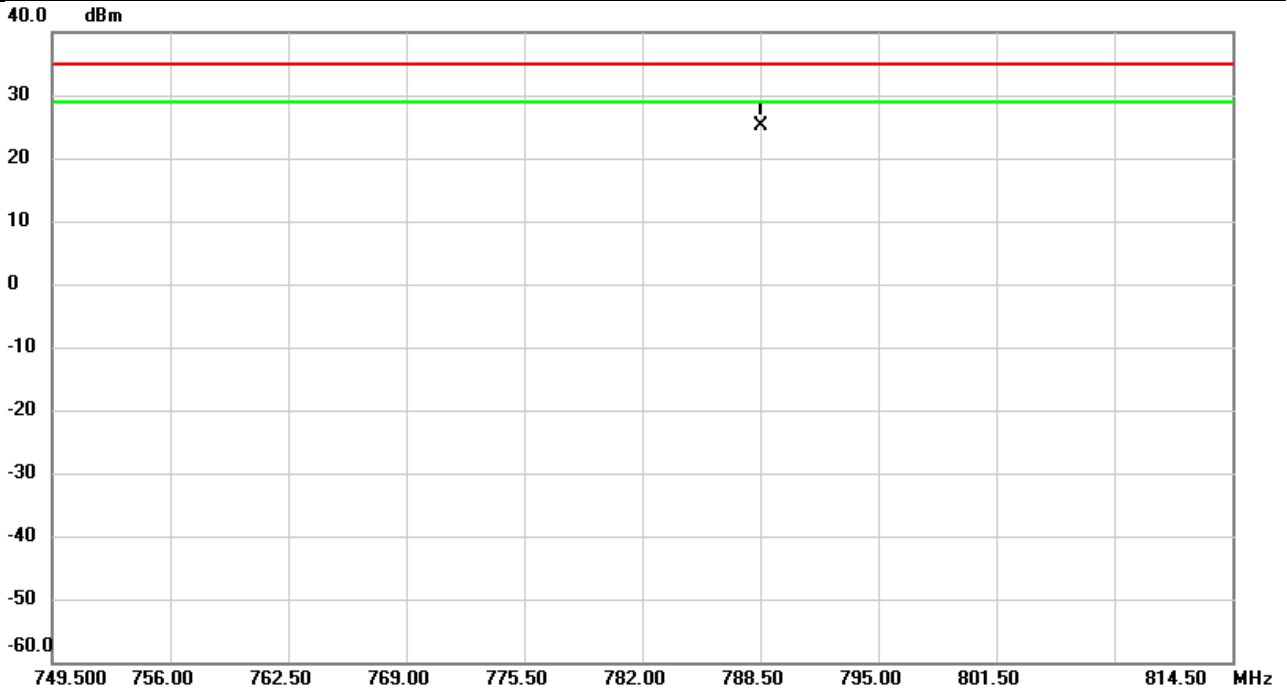

No.	Mk.	Freq.	Reading Level	Correct Factor	Measurement	Limit	Over	Detector	Comment
		MHz	dBm	dB	dBm	dBm	dB		
1	*	788.5585	14.78	10.25	25.03	34.77	-9.74	peak	

REMARKS:

- (1) Measurement Value = Reading Level + Correct Factor.
- (2) Margin Level = Measurement Value - Limit Value.

## APPENDIX C RADIATED SPURIOUS EMISSIONS

Test Mode	LTE Band 14	Test Date	2022/9/1
Test Channel	CH23330	Polarization	Vertical
Temp	26°C	Hum.	60%

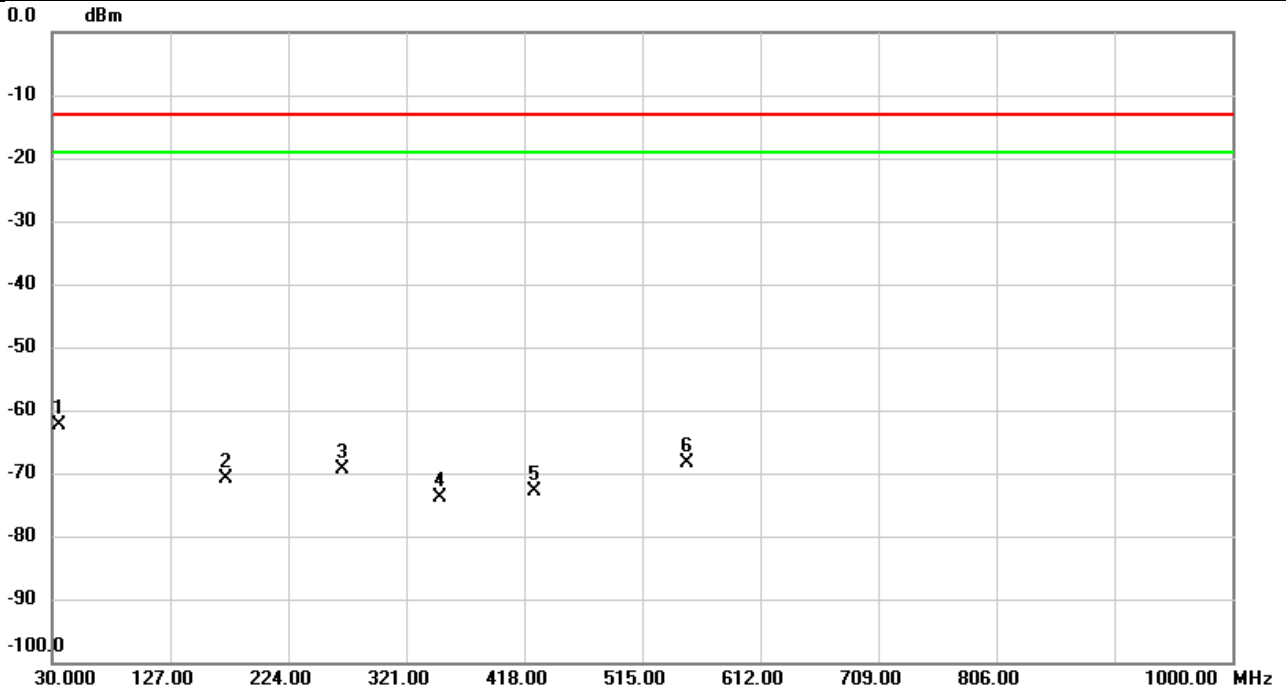

No.	Mk.	Freq.	Reading Level	Correct Factor	Measurement	Limit	Over	Detector	Comment
		MHz	dBm	dB	dBm	dBm	dB		
1	*	36.2403	-87.16	24.67	-62.49	-13.00	-49.49	peak	
2		173.4307	-89.04	18.12	-70.92	-13.00	-57.92	peak	
3		268.2643	-82.57	13.25	-69.32	-13.00	-56.32	peak	
4		349.1300	-84.89	11.04	-73.85	-13.00	-60.85	peak	
5		425.9863	-83.53	10.59	-72.94	-13.00	-59.94	peak	
6		552.3127	-80.90	12.65	-68.25	-13.00	-55.25	peak	

**REMARKS:**

- (1) Measurement Value = Reading Level + Correct Factor.
- (2) Margin Level = Measurement Value - Limit Value.

Test Mode	LTE Band 14	Test Date	2022/9/1
Test Channel	CH23330	Polarization	Horizontal
Temp	26°C	Hum.	60%

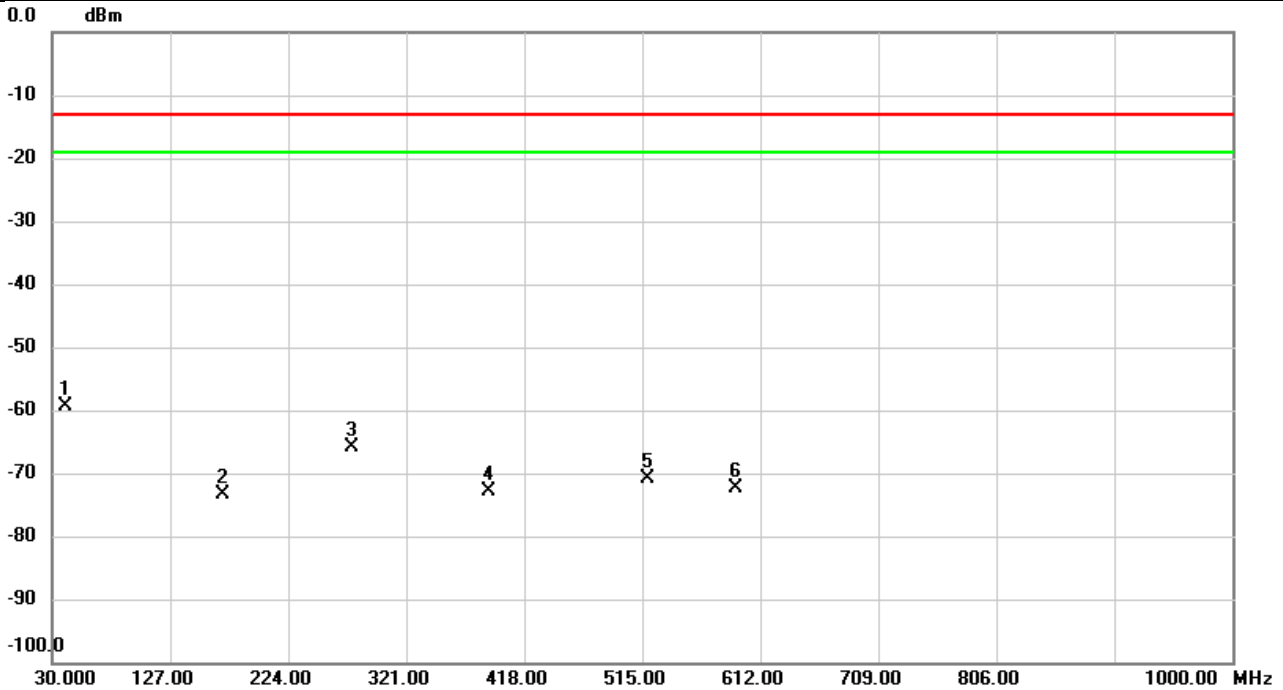

No.	Mk.	Freq.	Reading Level	Correct Factor	Measurement	Limit	Over	Detector	Comment
		MHz	dBm	dB	dBm	dBm	dB		
1	*	40.4437	-94.98	35.65	-59.33	-13.00	-46.33	peak	
2		170.2620	-88.61	15.23	-73.38	-13.00	-60.38	peak	
3		276.0242	-74.62	8.87	-65.75	-13.00	-52.75	peak	
4		389.4173	-83.41	10.64	-72.77	-13.00	-59.77	peak	
5		519.3650	-80.35	9.50	-70.85	-13.00	-57.85	peak	
6		592.3090	-81.91	9.66	-72.25	-13.00	-59.25	peak	

**REMARKS:**

- (1) Measurement Value = Reading Level + Correct Factor.
- (2) Margin Level = Measurement Value - Limit Value.

Test Mode	LTE Band 14	Test Date	2022/8/31
Test Channel	CH23330	Polarization	Vertical
Temp	26°C	Hum.	60%

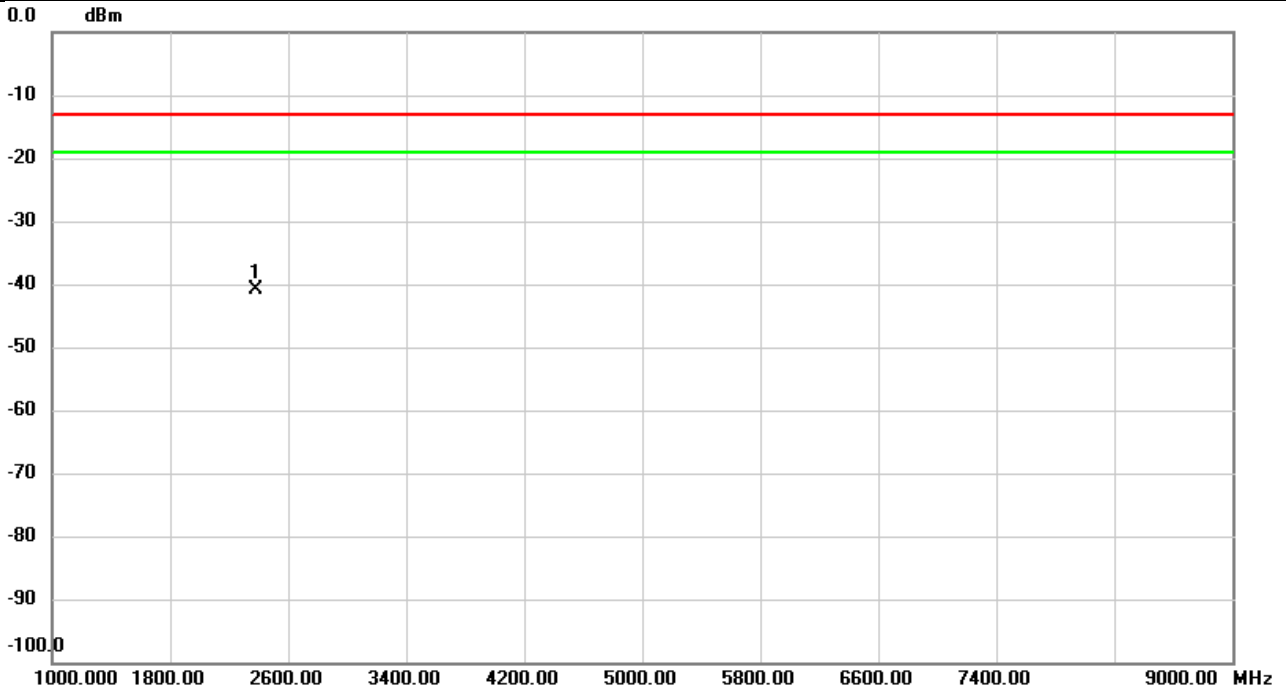

No.	Mk.	Freq.	Reading Level	Correct Factor	Measurement	Limit	Over	Detector	Comment
		MHz	dBm	dB	dBm	dBm	dB		
1	*	2382.133	-47.37	6.43	-40.94	-13.00	-27.94	peak	

REMARKS:

- (1) Measurement Value = Reading Level + Correct Factor.
- (2) Margin Level = Measurement Value - Limit Value.



Test Mode	LTE Band 14	Test Date	2022/8/31
Test Channel	CH23330	Polarization	Horizontal
Temp	26°C	Hum.	60%

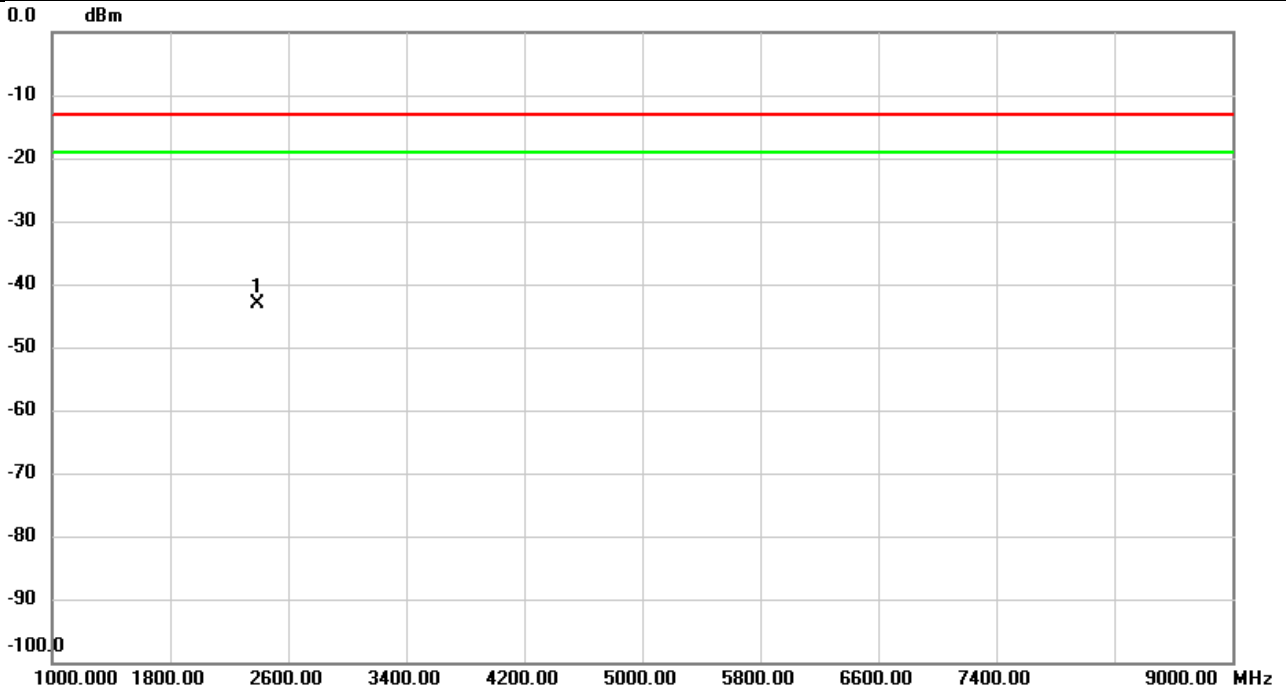

No.	Mk.	Freq.	Reading Level	Correct Factor	Measurement	Limit	Over	Detector	Comment
		MHz	dBm	dB	dBm	dBm	dB		
1	*	2386.933	-49.30	6.20	-43.10	-13.00	-30.10	peak	

**REMARKS:**

- (1) Measurement Value = Reading Level + Correct Factor.
- (2) Margin Level = Measurement Value - Limit Value.

**End of Test Report**