

RF Test Report

Applicant : Getac Technology Corporation
Product Type : NFC Module
Trade Name : Getac
Model Number : UX10 PN7462 NFC Module
Test Specification : FCC 47 CFR PART 15 SUBPART C
ANSI C63.10:2013
Receive Date : Mar. 08, 2019
Test Period : Mar. 26 ~ Mar. 29, 2019
Issue Date : Apr. 03, 2019

Issue by

A Test Lab Techno Corp.
No. 140-1, Changan Street, Bade District,
Taoyuan City 33465, Taiwan (R.O.C.)
Tel : +886-3-2710188 / Fax : +886-3-2710190



Taiwan Accreditation Foundation accreditation number: 1330
Test Firm MRA designation number: TW0010

Note: This report shall not be reproduced except in full, without the written approval of A Test Lab Techno Corp. This document may be altered or revised by A Test Lab Techno Corp. personnel only, and shall be noted in the revision section of the document. The client should not use it to claim product endorsement by TAF, or any government agencies. The test results in the report only apply to the tested sample.



Revision History

Rev.	Issue Date	Revisions	Revised By
00	Apr. 03, 2019	Initial Issue	Janet Chao

Verification of Compliance

Issued Date: Apr. 03, 2019

Applicant : Getac Technology Corporation
Product Type : NFC Module
Trade Name : Getac
Model Number : UX10 PN7462 NFC Module
FCC ID : QYLPN7462U
EUT Rated Voltage : DC 5 V
Test Voltage : 120 Vac / 60 Hz
Applicable Standard : FCC 47 CFR PART 15 SUBPART C
ANSI C63.10:2013
Test Result : Complied
Performing Lab. : A Test Lab Techno Corp.

No. 140-1, Changan Street, Bade District,
Taoyuan City 33465, Taiwan (R.O.C.)

Tel : +886-3-2710188 / Fax : +886-3-2710190

Taiwan Accreditation Foundation accreditation number: 1330

<http://www.atl-lab.com.tw/e-index.htm>



A Test Lab Techno Corp. tested the above equipment in accordance with the requirements set forth in the above standards. All indications of Pass/Fail in this report are opinions expressed by A Test Lab Techno Corp. based on interpretations and/or observations of test results. The test results show that the equipment tested is capable of demonstrating compliance with the requirements as documented in this report.

Approved By : Fly Lu Reviewed By : Eric Ou Yang
(Manager) (Fly Lu) (Testing Engineer) (Eric Ou Yang)



TABLE OF CONTENTS

1	General Information	5
1.1.	Summary of Test Result.....	5
1.2.	Measurement Uncertainty.....	6
2	EUT Description	7
3	Test Methodology.....	8
3.1.	Mode of Operation.....	8
3.2.	EUT Test Step.....	8
3.3.	Configuration of Test System Details	9
3.4.	Test Instruments	10
3.5.	Test Site Environment.....	11
4	Measurement Procedure.....	12
4.1.	AC Power Line Conducted Emission Measurement.....	12
4.2.	Radiated Emission Measurement	14
4.3.	Frequency Stability Measurement.....	18
4.4.	20 dB Bandwidth Measurement.....	20
4.5.	Antenna Requirement.....	21
5	Test Results.....	22
	Annex A. Conducted Emission	22
	Annex B. Conducted Test Results	24
	Annex C. Radiated Emission Measurement	26



1 General Information

1.1. Summary of Test Result

Standard	Item	Results	Remark
FCC			
15.203	Antenna Requirement	Meet Require	---
15.207(a)	Conducted Emissions Voltage	PASS	---
15.225 (a), (b), (c), (d) 15.209	Radiated Emission Limits	PASS	---
15.225(e)	Frequency Stability	PASS	---
15.215(c)	20 dB Bandwidth	-----	---
CFR 47 Part 15.225 / ANSI C63.10:2013			

The test results of this report relate only to the tested sample(s) identified in this report.

Standard	Description
CFR47, Part 15, Subpart C	Intentional Radiators
ANSI C63. 10: 2013	American National Standard of Procedures for Compliance Testing of Unlicensed Wireless Devices



1.2. Measurement Uncertainty

Test Item	Frequency Range	Uncertainty
Conducted Emission	9 kHz ~ 150 kHz	2.7
	150 kHz ~ 30 MHz	2.7
Radiated Emission	9 kHz ~ 30 MHz	1.7
	30 MHz ~ 1000 MHz	5.7
	1000 MHz ~ 18000 MHz	5.5
	18000 MHz ~ 26500 MHz	4.8
	26500 MHz ~ 40000 MHz	4.8
RF Bandwidth		4.96 %
Frequency Stability		+ 2.212 x 10 ⁻⁷ % / - 2.170 x 10 ⁻⁷

2 EUT Description

Applicant	Getac Technology Corporation 5F., Building A, No.209, Sec.1, Nangang Rd., Nangang Dist., Taipei City, 11568, Taiwan
Manufacturer	Infothink DaLing Village, DaLingShan Town, DongGuan city, GuangDong Province,China
Product	NFC Module
Trade Name	Getac
Model Number	UX10 PN7462 NFC Module
FCC ID	QYLPN7462U
Frequency Range	13.56 MHz
Modulation Type	PSK
Number of Channels	1 Channel
Antenna Type	Loop Antenna
Operate Temp. Range	-10 ~ +60 °C

3 Test Methodology

3.1. Mode of Operation

The following test mode(s) were scanned during the preliminary test :

Test Mode
Mode 1: Transmit Mode
Mode 2: Continuous TX Mode

After verification, all tests were carried out with the worst case test modes.

ATL has verified the construction and function in typical operation. All the test modes were carried out with the EUT in normal operation.

3.2. EUT Test Step

1.	Setup the EUT shown on "Configuration of Test System Details."
2.	Turn on the power of all equipment.
3.	The EUT will start to operate function.

Measurement Software			
No.	Description	Software	Version
1	Conducted Emission	EZ EMC	1.1.4.3
2	Radiated Emission	EZ EMC	1.1.4.4

3.3. Configuration of Test System Details

Conducted Emission

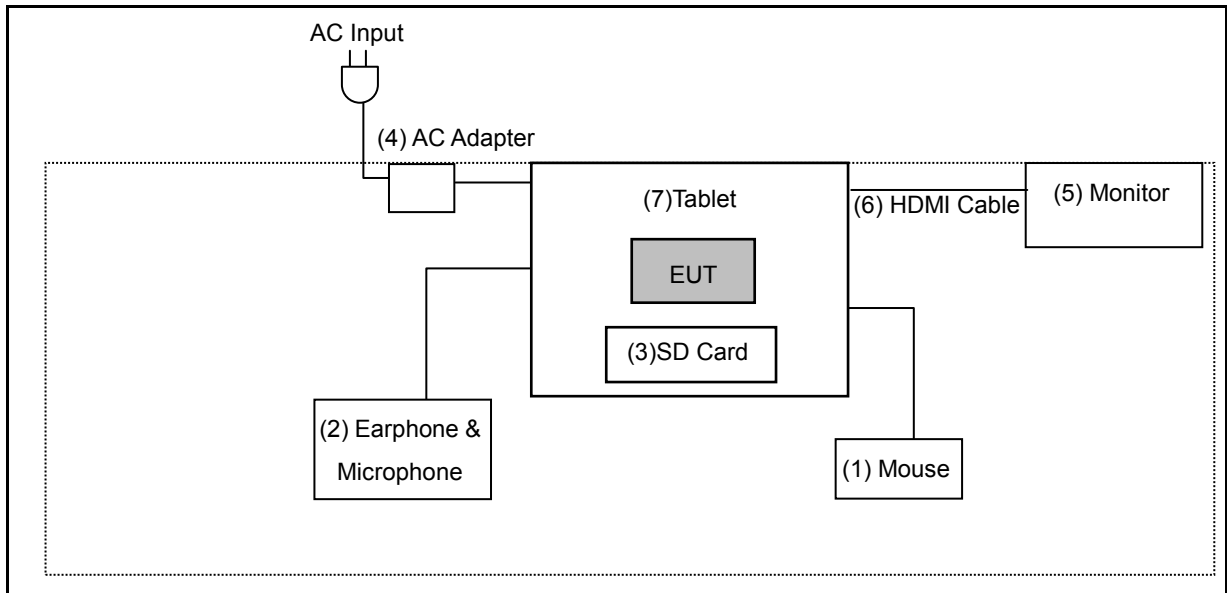

Radiated Emission

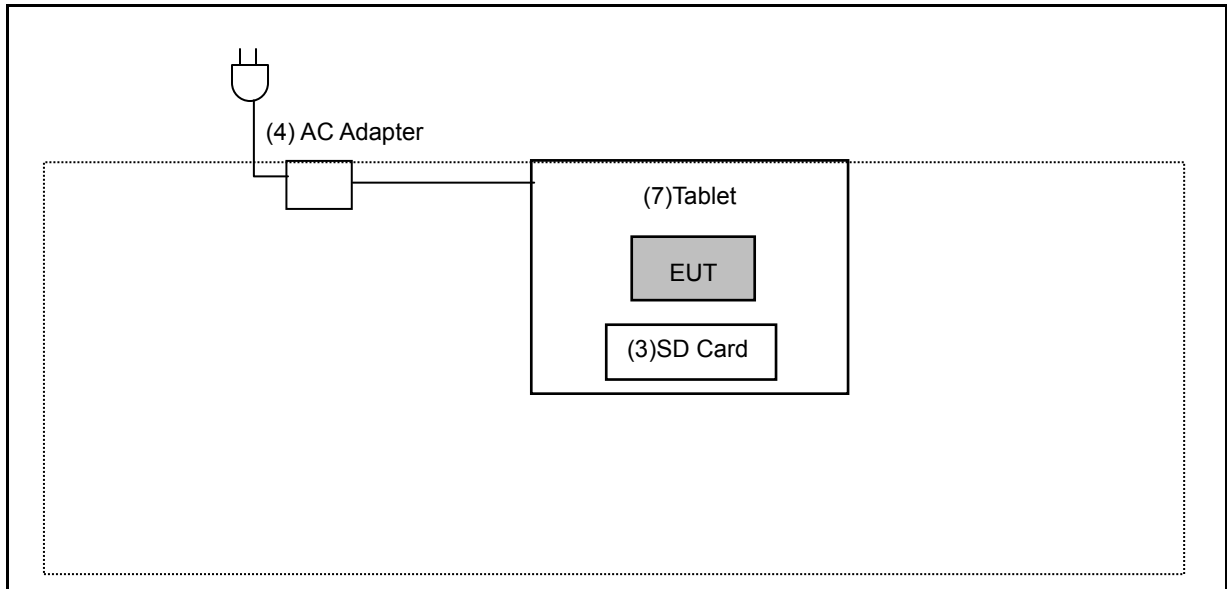

Devices Description					
Product		Manufacturer	Model Number	Serial Number	Power Cord
(1)	Mouse	Logitech	M-UAG96B	---	---
(2)	Earphone & Microphone	HTC	---	---	---
(3)	SD Card	Transcend	---	---	---
(4)	AC Adapter	FSP	FSP065-RBBN3	---	---
(5)	Monitor	DELL	P2415Qb	CN-0D3C8Y-74261-523-0HUL	---
(6)	HDMI Cable	Avier	K48GHS	---	---
(7)	Tablet	Getac	UX10	---	---

3.4. Test Instruments

Conducted Emission

Test Period: Mar. 27, 2019

名稱	廠牌	型號	序號	本次校驗日期	校驗年限
Test Receiver	R&S	ESCI	100367	05/21/2018	1 year
LISN	R&S	ENV216	101040	04/11/2018	1 year
RF Cable	Woken	00100D138019 4M	TE-02-03	05/17/2018	1 year

Conducted / Radiated Emissions

Test Period: Mar. 26 ~ Mar. 29, 2019

名稱	廠牌	型號	序號	本次校驗日期	校驗年限
Spectrum Analyzer (10 Hz~44 GHz)	Keysight	N9010A	MY52221312	01/14/2019	1 year
Pre Amplifier (100 kHz~1.3 GHz)	Agilent	8447D	2944A11119	01/14/2019	1 year
Broadband Antenna	Schwarzbeck	VULB9168	416	10/19/2018	1 year
Loop Antenna	Electro-Metrics	EMCI-LPA600	277	04/19/2018	1 year
RF Cable	EMCI	EMC104-N-N-600 0	TE01-1	02/20/2019	1 year
Microwave Cable	EMCI	EMC104-SM-SM- 13000	170814	10/30/2018	1 year
Microwave Cable	EMCI	EMC102-KM-KM- 14000	151001	02/20/2019	1 year

3.5. Test Site Environment

Items	Required (IEC 60068-1)	Actual
Temperature (°C)	15-35	26
Humidity (%RH)	25-75	60
Barometric pressure (mbar)	860-1060	990

4 Measurement Procedure

4.1. AC Power Line Conducted Emission Measurement

■ Limit

Frequency (MHz)	Quasi-peak	Average
0.15 - 0.5	66 to 56	56 to 46
0.50 - 5.0	56	46
5.0 - 30.0	60	50

■ Test Setup

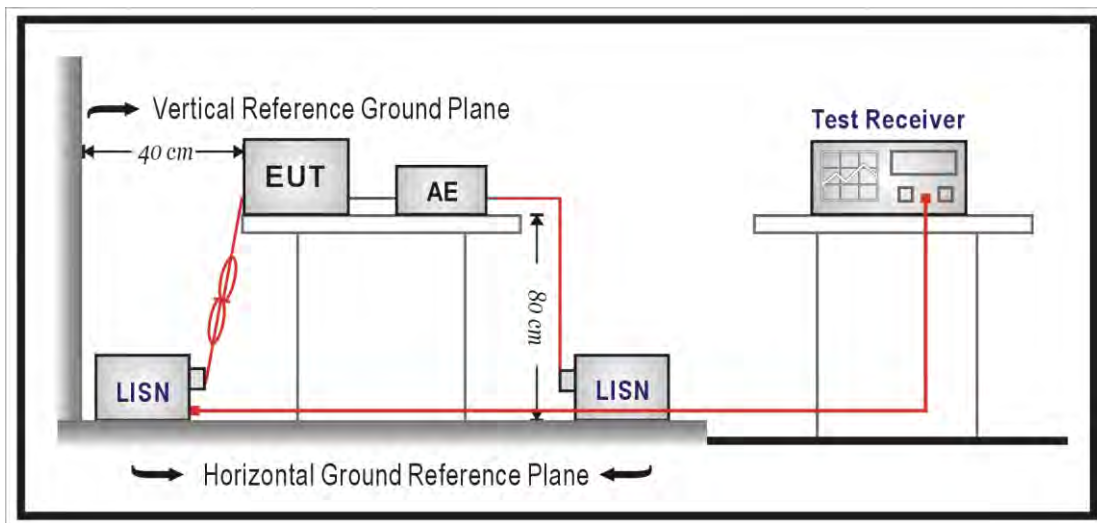

■ Test Procedure

The EUT and simulators are connected to the main power through a line impedance stabilization network (L.I.S.N.). This provides a $50 \Omega // 50 \mu\text{H}$ coupling impedance for the measuring equipment. The peripheral devices are also connected to the main power through a LISN that provides a $50 \Omega // 50 \mu\text{H}$ coupling impedance with 50 ohm termination.

Tabletop device shall be placed on a non-conducting platform, of nominal size 1 m by 1.5 m, raised 80 cm above the reference ground plane. The wall of screened room shall be located 40 cm to the rear of the EUT. Other surfaces of tabletop or floor standing EUT shall be at least 80 cm from any other ground conducting surface including one or more LISNs. For floor-standing device shall be placed under the EUT with a 12 mm insulating material.

Conducted emissions were investigated over the frequency range from 0.15 MHz to 30 MHz using a resolution bandwidth of 9 kHz. The equipment under test (EUT) shall be meet the limits in section 4.1, as applicable, including the average limit and the quasi-peak limit when using respectively, an average detector and quasi-peak detector measured in accordance with the methods described of related standard. When all of peak value were complied with quasi-peak and average limit from 150 kHz to 30 MHz then quasi-peak and average measurement was unnecessary.

The AMN shall be placed 0.8 m from the boundary of the unit under test and bonded to a ground reference plane for AMNs mounted on top of the ground reference plane. This distance is between the closest points of the AMN and the EUT. All other units of the EUT and associated equipment shall be at least 0.8 m from the AMN. If the mains power cable is longer than 1 m then the cable shall be folded back and forth at the centre of the lead to form a bundle no longer than 0.4 m. All of interconnecting cables that hang closer than 40 cm to the ground plane shall be folded back and forth in the center forming a bundle 30 cm to 40 cm long. All of EUT and AE shall be separate place more than 0.1 m. All 50Ω ports of the LISN shall be resistively terminated into 50Ω loads when not connected to the measuring instrument.

If the reading of the measuring receiver shows fluctuations close to the limit, the reading shall be observed for at least 15 s at each measurement frequency; the higher reading shall be recorded with the exception of any brief isolated high reading which shall be ignored.



4.2. Radiated Emission Measurement

■ Limit

According to §15.225,

- (a) The field strength of any emissions within the band 13.553 – 13.567 MHz shall not exceed 15,848 microvolt / meter at 30 meters.
- (b) Within the bands 13.410 – 13.553 MHz and 13.567 -13.710 MHz, the field strength of any emissions shall not exceed 334 microvolt / meter at 30 meters.
- (c) Within the bands 13.110 – 13.410 MHz and 13.710 – 14.010 MHz the field strength of any emissions shall not exceed 106 microvolt / meter at 30 meters.
- (d) The field strength of any emissions appearing outside of the 13.110 – 14.010 MHz and shall not exceed the general radiated emission limits in §15.209.

According to §15.225(a), except as provided elsewhere in this Subpart, the emissions from an intentional radiator shall not exceed the field strength levels specified in the following table:

Frequency (MHz)	Field Strength ($\mu\text{V}/\text{m}$ at meter)	Measurement Distance (meter)
0.009 – 0.490	2400 / F (kHz)	300
0.490 – 1.705	24000 / F (kHz)	30
1.705 – 30.0	30	30
30 - 88	100**	3
88-216	150**	3
216-960	200**	3
Above 960	500	3

** Except as provided in paragraph (g), fundamental emissions from intentional radiators operating under this Section shall not be located in the frequency bands 54-72 MHz, 76-88 MHz, 174-216 MHz or 470-806 MHz. However, operation within these frequency bands is permitted under other sections of this Part, e.g., Sections 15.231 and 15.241.

■ Setup
9 kHz ~ 30 MHz

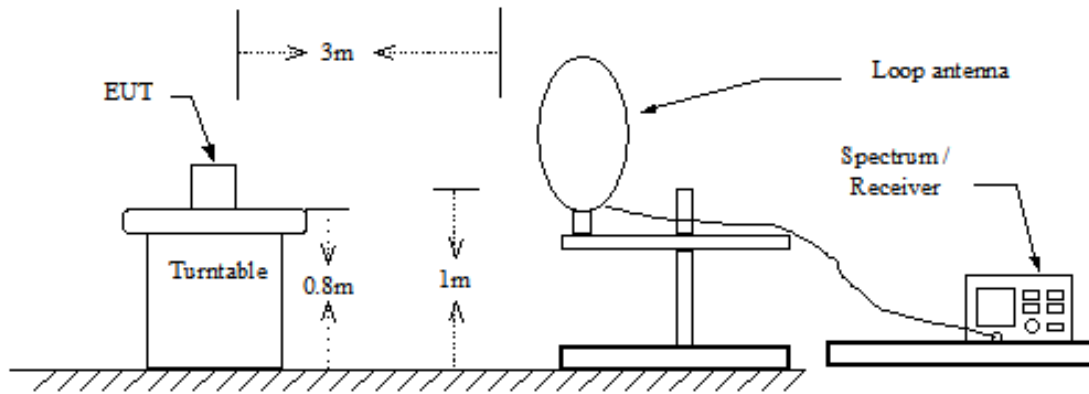

30 MHz ~ 1 GHz

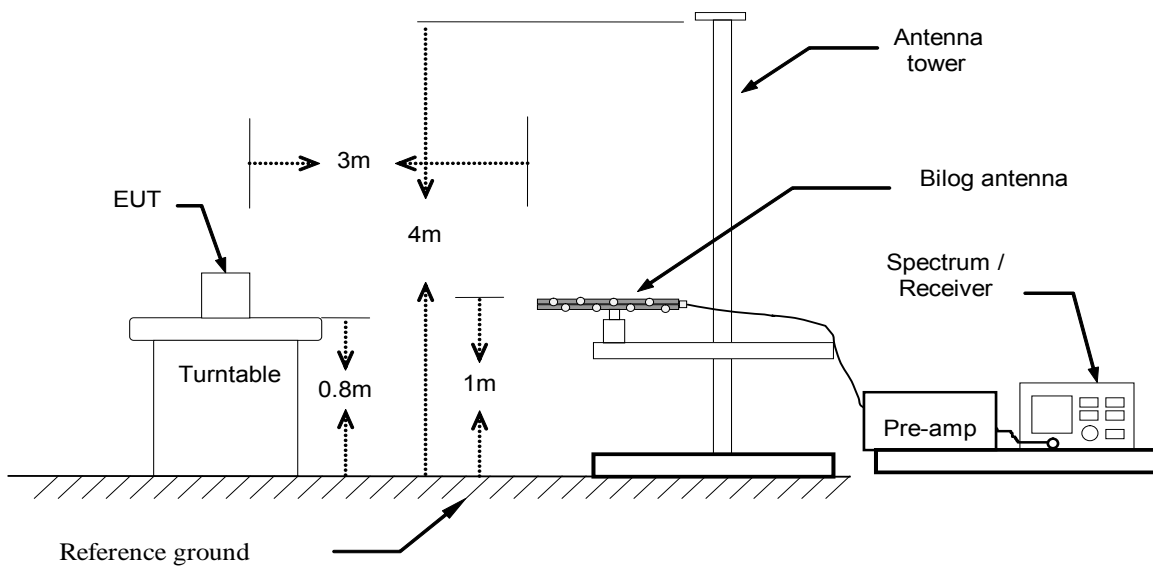

■ Test Procedure

Final radiation measurements were made on a three-meter Semi Anechoic Chamber. The EUT system was placed on a nonconductive turntable which is 0.8 meters height, top surface 1.0 x 1.5 meter. The spectrum was examined from 3 Hz to 44 GHz in order to cover the whole spectrum below 10th harmonic which could generate from the EUT. During the test, EUT was set to transmit continuously.

For measurements below 1 GHz the resolution bandwidth is set to 100 kHz for peak detection measurements or 120 kHz for quasi-peak detection measurements. Peak detection is used unless otherwise noted as quasi-peak.

For measurements above 1 GHz the resolution bandwidth is set to 1 MHz, and then the video bandwidth is set to 3 MHz for peak measurements and 10 Hz for average measurements.

A nonconductive material surrounded the EUT to supporting the EUT for standing on three orthogonal planes. At each condition, the EUT was rotated 360 degrees, and the antenna was raised and lowered from one to four meters to find the maximum emission levels. Measurements were taken using both horizontal and vertical antenna polarization.

Broadband/Horn Antenna were used in frequency 30 MHz to 18 GHz at a distance of 3 meter. Loop/Horn Antenna was used in frequency 9 kHz to 30 MHz and 18 to 26.5 GHz at a distance of 1 meter. All test results were extrapolated to equivalent signal at 3 meters utilizing an inverse linear distance extrapolation Factor (20 dB/decade).

For testing above 1 GHz, the emission level of the EUT in peak mode was 20 dB lower than average limit (that means the emission level in peak mode also complies with the limit in average mode), then testing will be stopped and peak values of EUT will be reported, otherwise, the emissions will be measured in average mode again and reported.

Appropriate preamplifiers were used for improving sensitivity and precautions were taken to avoid overloading or desensitizing the spectrum analyzer. No post – detector video filters were used in the test.

The spectrum analyzer's 6 dB bandwidth was set to 1 MHz, and the analyzer was operated in the peak detection mode, for frequencies both below and up 1 GHz. The average levels were obtained by subtracting the duty cycle correction factor from the peak readings.

The following procedures were used to convert the emission levels measured in decibels referenced to 1 microvolt (dBuV) into field intensity in microvolt per-meter (uV/m).

The actual field intensity in decibels referenced to 1 microvolt in to field intensity in microvolt per-meter (dBuV/m).



The actual field intensity in referenced to 1 microvolt per meter (dBuV/m) is determined by algebraically adding the measured reading in dBuV, the antenna factor (dB), and cable loss (dB) and Subtracting the gain of preamplifier (dB) is auto calculate in spectrum analyzer.

$$(1) \text{ Amplitude (dBuV/m) = FI (dBuV) +AF (dBuV) +CL (dBuV)-Gain (dB)}$$

FI= Reading of the field intensity.

AF= Antenna factor.

CL= Cable loss.

P.S Amplitude is auto calculate in spectrum analyzer.

$$(2) \text{ Actual Amplitude (dBuV/m) = Amplitude (dBuV)-Dis(dB)}$$

The FCC specified emission limits were calculated according the EUT operating frequency and by following linear interpolation equations:

(a) For fundamental frequency : Transmitter Output < +30 dBm

(b) For spurious frequency : Spurious emission limits = fundamental emission limit /10

Data of measurement within this frequency range without mark in the table above means the reading of emissions are attenuated more than 20 dB below the permissible limits or the field strength is too small to be measured.

4.3. Frequency Stability Measurement

■ Limit

According to §15.207(e), the frequency tolerance of the carrier signal shall be maintained within +/- 0.01 % of the operating frequency over a temperature variation of -20 degrees to +50 degrees C at normal supply voltage, and for a variation in the primary supply voltage from 85 % to 115 % of the rated supply voltage at a temperature of 20 degrees C. For battery operated equipment, the equipment tests shall be performed using a new battery.

■ Test Setup

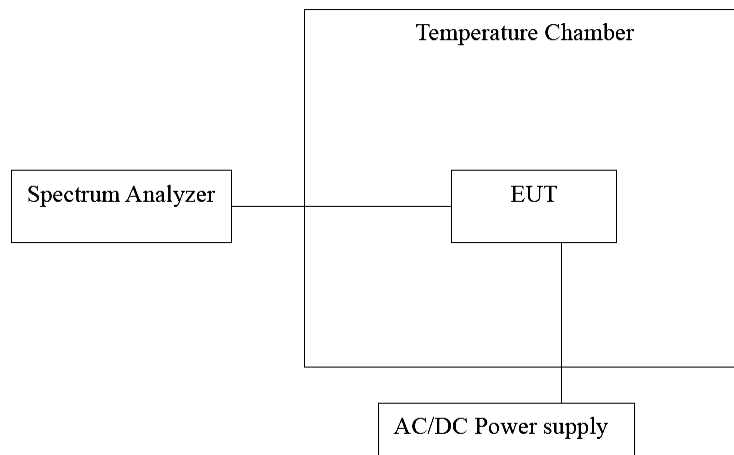



■ **Test Procedure**

1. Place the EUT on the table and set it in the transmitting mode.
2. Remove the antenna from the EUT and then connect a low loss RF cable from the antenna port to the spectrum analyzer.
3. Set the environment into appropriate environment.
4. Set the spectrum analyzer as RBW = 1 kHz, VBW = RBW, Span = 200 kHz, Sweep = auto.
5. Mark the peak frequency and measure the frequency tolerance using frequency counter function.
6. Repeat until all the results are investigated.

4.4. 20 dB Bandwidth Measurement

■ **Limit**

N/A

■ **Test Setup**

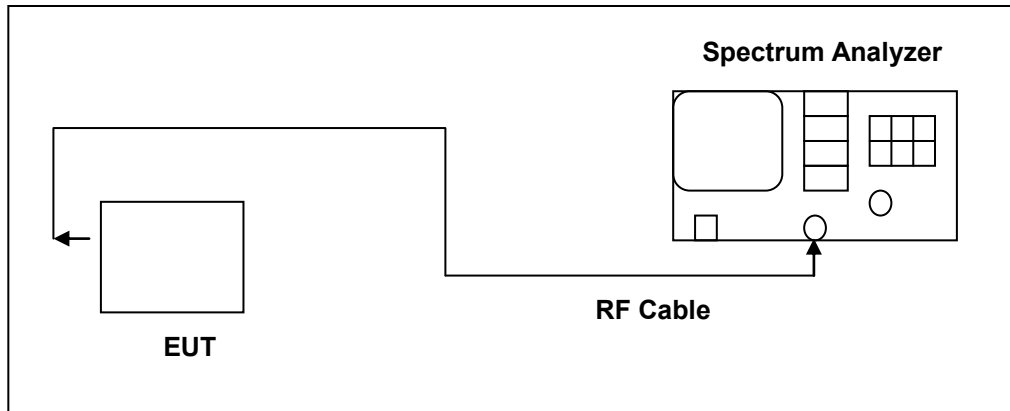

■ **Test Procedure**

Connect RF output port to the input of the spectrum analyzer. Connect the DUT to appropriate power supply. Turn RFID function of DUT on.

Analyzer used the following settings:

1. Span = 60 kHz
2. RBW \geq 1 % of the 20 dB span
3. VBW \geq RBW
4. Sweep = auto
5. Detector function = peak
6. Trace = max hold

The trace was allowed to stabilize. The EUT was transmitting at its maximum data rate. The marker-to-peak function was used to set the marker to the peak of the emission. The marker-delta function was used to measure 20 dB down one side of the emission. The marker-delta function and marker was moved to the other side of the emission until it was even with the reference marker. The marker-delta reading at this point was the 20 dB bandwidth of the emission.



4.5. Antenna Requirement

■ **Require**

An intentional radiator shall be designed to ensure that no antenna other than that furnished by the responsible party shall be used with the device. The use of a permanently attached antenna or of an antenna that uses a unique coupling to the intentional radiator shall be considered sufficient to comply with the provisions of this section. The manufacturer may design the unit so that a broken antenna can be replaced by the user, but the use of a standard antenna jack or electrical connector is prohibited.

■ **Antenna Connector Construction**

The antenna connector used in this product is internal antenna, cannot be replaced by the end-user. See section 2 – antenna information.



5 Test Results

Annex A. Conducted Emission

Standard:	FCC Part 15.225	Line:	L1
Test item:	Conducted Emission	Power:	AC 120 V/60 Hz
Test Mode:	Mode 1	Temp.(°C)/Hum.(%RH):	26(°C)/60 %RH
Description:			

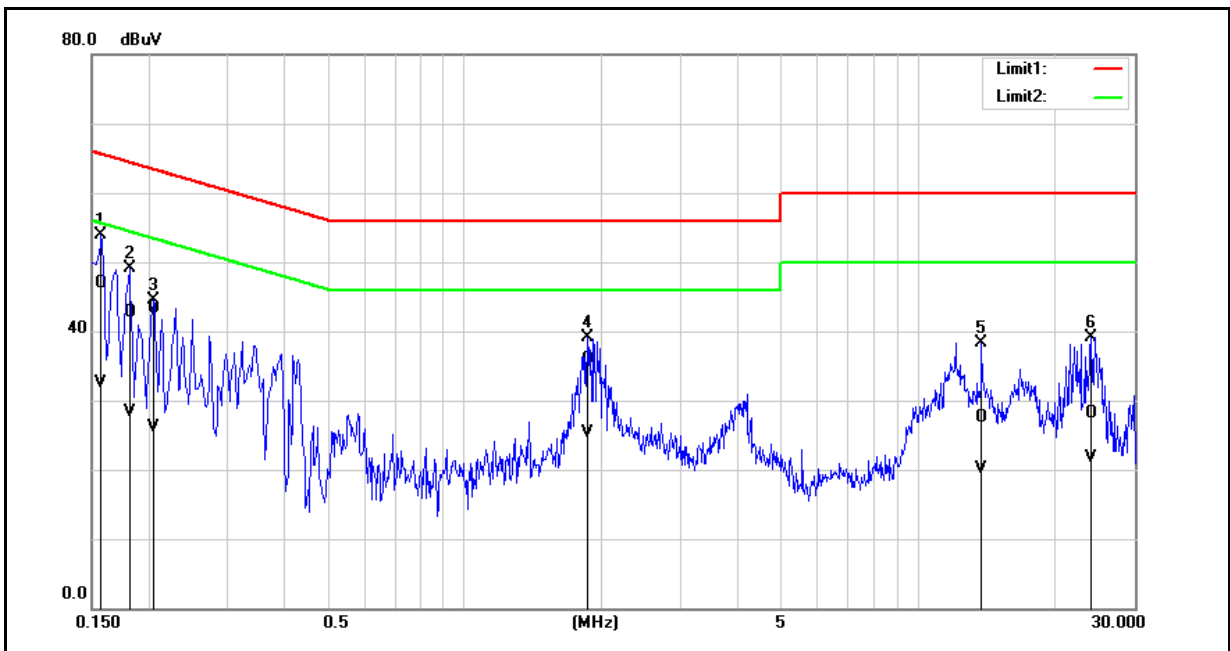

No.	Frequency (MHz)	QP reading (dBuV)	AVG reading (dBuV)	Correction factor (dB)	QP result (dBuV)	AVG result (dBuV)	QP limit (dBuV)	AVG limit (dBuV)	QP margin (dB)	AVG margin (dB)	Remark
1	0.1580	37.42	23.03	9.52	46.94	32.55	65.57	55.57	-18.63	-23.02	Pass
2	0.1820	33.09	18.75	9.52	42.61	28.27	64.39	54.39	-21.78	-26.12	Pass
3	0.2060	33.88	16.67	9.52	43.40	26.19	63.37	53.37	-19.97	-27.18	Pass
4	1.8660	26.29	15.70	9.60	35.89	25.30	56.00	46.00	-20.11	-20.70	Pass
5	13.7740	17.76	10.28	9.81	27.57	20.09	60.00	50.00	-32.43	-29.91	Pass
6	24.1060	18.24	11.84	9.88	28.12	21.72	60.00	50.00	-31.88	-28.28	Pass

Note: 1. Result (dBuV) = Correction factor (dB) + Reading(dBuV).

2. Correction factor (dB) = Cable loss (dB) + L.I.S.N. factor (dB).

Standard:	FCC Part 15.225	Line:	N
Test item:	Conducted Emission	Power:	AC 120 V/60 Hz
Test Mode:	Mode 1	Temp.(°C)/Hum.(%RH):	26(°C)/60 %RH
Description:			

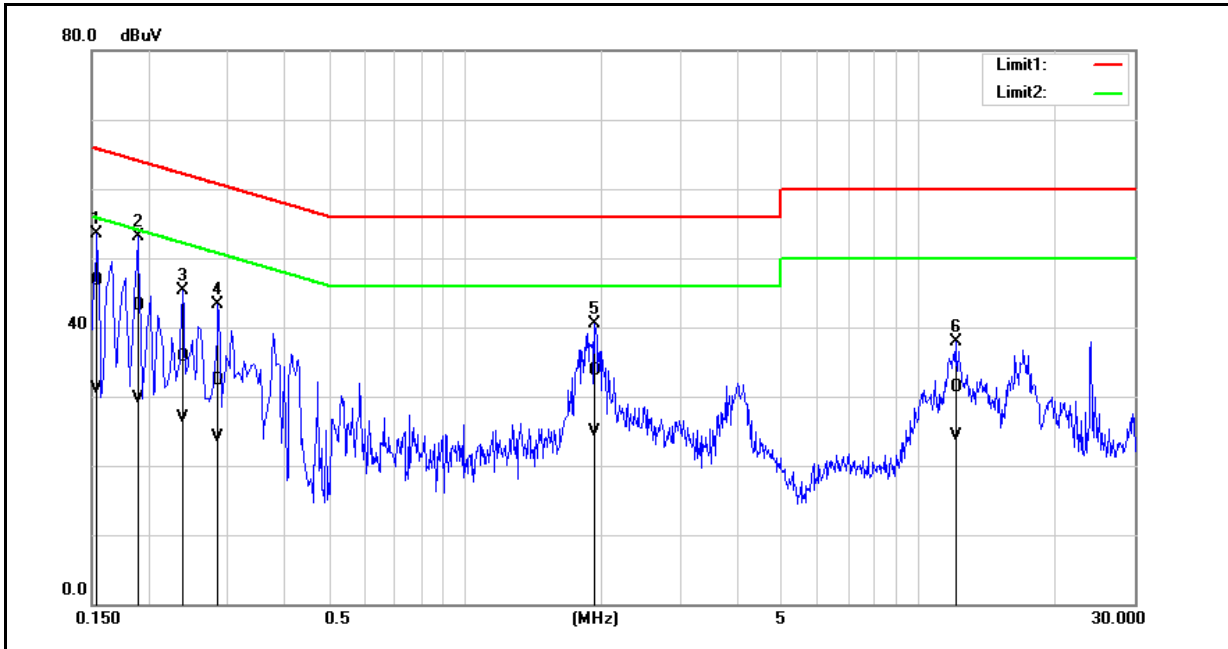

No.	Frequency (MHz)	QP reading (dBuV)	AVG reading (dBuV)	Correction factor (dB)	QP result (dBuV)	AVG result (dBuV)	QP limit (dBuV)	AVG limit (dBuV)	QP margin (dB)	AVG margin (dB)	Remark
1	0.1540	37.10	21.48	9.60	46.70	31.08	65.78	55.78	-19.08	-24.70	Pass
2	0.1900	33.58	20.08	9.59	43.17	29.67	64.04	54.04	-20.87	-24.37	Pass
3	0.2380	26.07	17.35	9.59	35.66	26.94	62.17	52.17	-26.51	-25.23	Pass
4	0.2860	22.72	14.52	9.59	32.31	24.11	60.64	50.64	-28.33	-26.53	Pass
5	1.9300	24.04	15.27	9.66	33.70	24.93	56.00	46.00	-22.30	-21.07	Pass
6	12.0700	21.33	14.49	9.89	31.22	24.38	60.00	50.00	-28.78	-25.62	Pass

Note: 1. Result (dBuV) = Correction factor (dB) + Reading(dBuV).

2. Correction factor (dB) = Cable loss (dB) + L.I.S.N. factor (dB).



Annex B. Conducted Test Results

Frequency Stability Measurement

Temperature Variations

Test Mode		Mode 2					
Temp. (°C)	Voltage (VAC)	0 minute Frequency Tolerance (%)	2 minutes Frequency Tolerance (%)	5 minutes Frequency Tolerance (%)	10 minutes Frequency Tolerance (%)	Limit (%)	Result (Pass/Fail)
-20	V _{Nom}	-0.0071	-0.0070	-0.0074	-0.0074	±0.01	Pass
-10	V _{Nom}	-0.0066	-0.0063	-0.0065	-0.0066	±0.01	Pass
0	V _{Nom}	-0.0058	-0.0055	-0.0058	-0.0059	±0.01	Pass
10	V _{Nom}	-0.0056	-0.0055	-0.0058	-0.0057	±0.01	Pass
20	V _{Nom}	-0.0055	-0.0055	-0.0055	-0.0055	±0.01	Pass
30	V _{Nom}	-0.0066	-0.0058	-0.0059	-0.0066	±0.01	Pass
40	V _{Nom}	-0.0055	-0.0055	-0.0065	-0.0066	±0.01	Pass
50	V _{Nom}	-0.0066	-0.0063	-0.0065	-0.0066	±0.01	Pass
60	V _{Nom}	-0.0066	-0.0063	-0.0065	-0.0074	±0.01	Pass

Voltage Variations

Test Mode		Mode 2					
Temp. (°C)	Voltage (VAC)	0 minute Frequency Tolerance (%)	2 minutes Frequency Tolerance (%)	5 minutes Frequency Tolerance (%)	10 minutes Frequency Tolerance (%)	Limit (%)	Result (Pass/Fail)
20	V _{Low}	-0.0055	-0.0055	-0.0065	-0.0066	±0.01	Pass
	V _{Nom}	-0.0055	-0.0055	-0.0055	-0.0055	±0.01	Pass
	V _{High}	-0.0055	-0.0063	-0.0065	-0.0055	±0.01	Pass

Note: V_{Low}=V_{Nom}-15 % ; V_{High}=V_{Nom}+15 %



20 dB Bandwidth Measurement

Test Mode	Mode 2		
Frequency (MHz)	20 dBc Low Point (MHz)	20 dBc High Point (MHz)	Operating Frequency Band (MHz)
13.5600	13.55865	13.56355	13.553~13.567

■ Test Graphs





Annex C. Radiated Emission Measurement

Fundamental Test Result:

Standard:	FCC Part 15.225	Test Distance:	1 m
Test item:	Fundamental	Power:	AC 120 V/60 Hz
Test Mode:	Mode 2	Temp.(°C)/Hum.(%RH):	26(°C)/60 %RH
Ant.Polar.:	Horizontal		

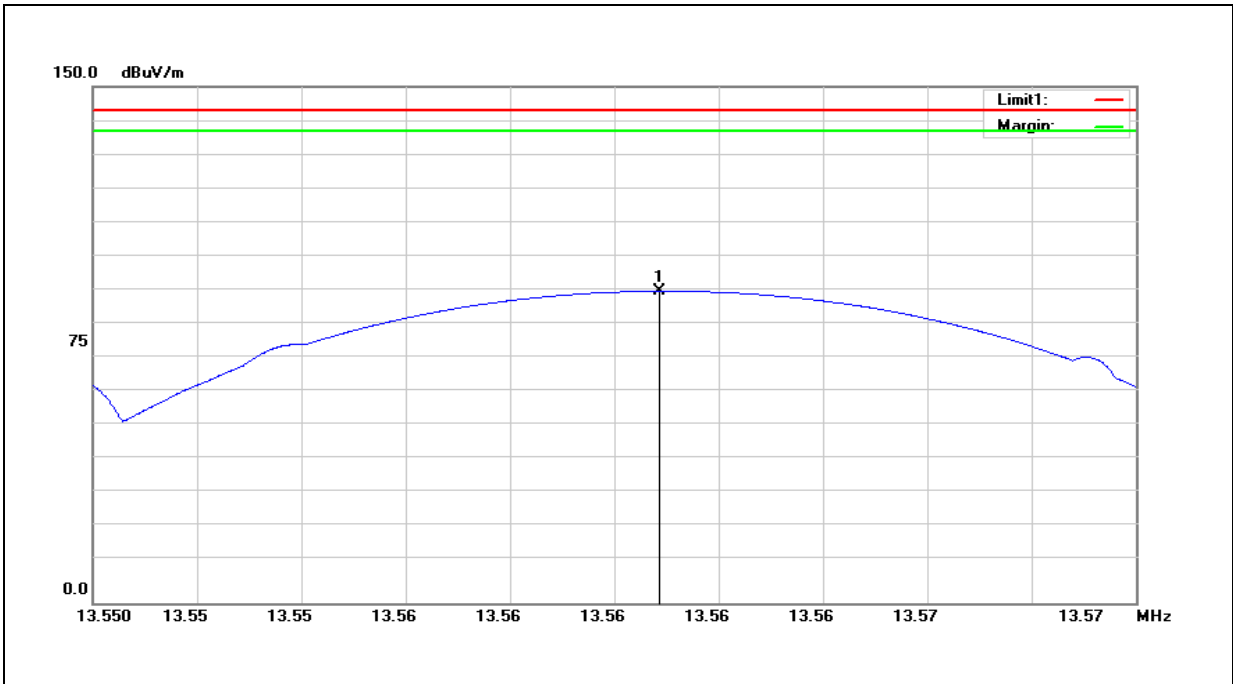

No.	Frequency (MHz)	Reading (dBuV)	Correct Factor (dB/m)	Near-Field Result (dBuV)	Derived Value (dBuV)	Limit (dBuV/m)	Margin (dB)	Remark
1	13.5610	52.80	37.80	90.60	50.13	84.00	-33.87	peak

Note: The level is measured at 1 meter and is converted into result at 30 meter.

The converted formula listed below:

Measure result (1 meter distance): a

Compute result (30 meter distance): A

$$d_{\text{near field}} = \lambda/2\pi \cdot d_{\text{measure}} = 1 \text{ meter distance}$$

$$A = a - 40 \cdot \log(d_{\text{near field}} / d_{\text{measure}}) - 20 \cdot \log(d_{\text{limit}} / d_{\text{near field}})$$

$$\text{ex. } a = 90.6 \text{ dBuV, } A = 90.6 - 40 \cdot \log(3.52 / 1) - 20 \cdot \log(30 / 3.52) \text{ dBuV} = 50.13 \text{ dBuV}$$



Standard:	FCC Part 15.225	Test Distance:	1 m
Test item:	Fundamental	Power:	AC 120 V/60 Hz
Test Mode:	Mode 2	Temp.(°C)/Hum.(%RH):	26(°C)/60 %RH
Ant.Polar.:	Vertical		

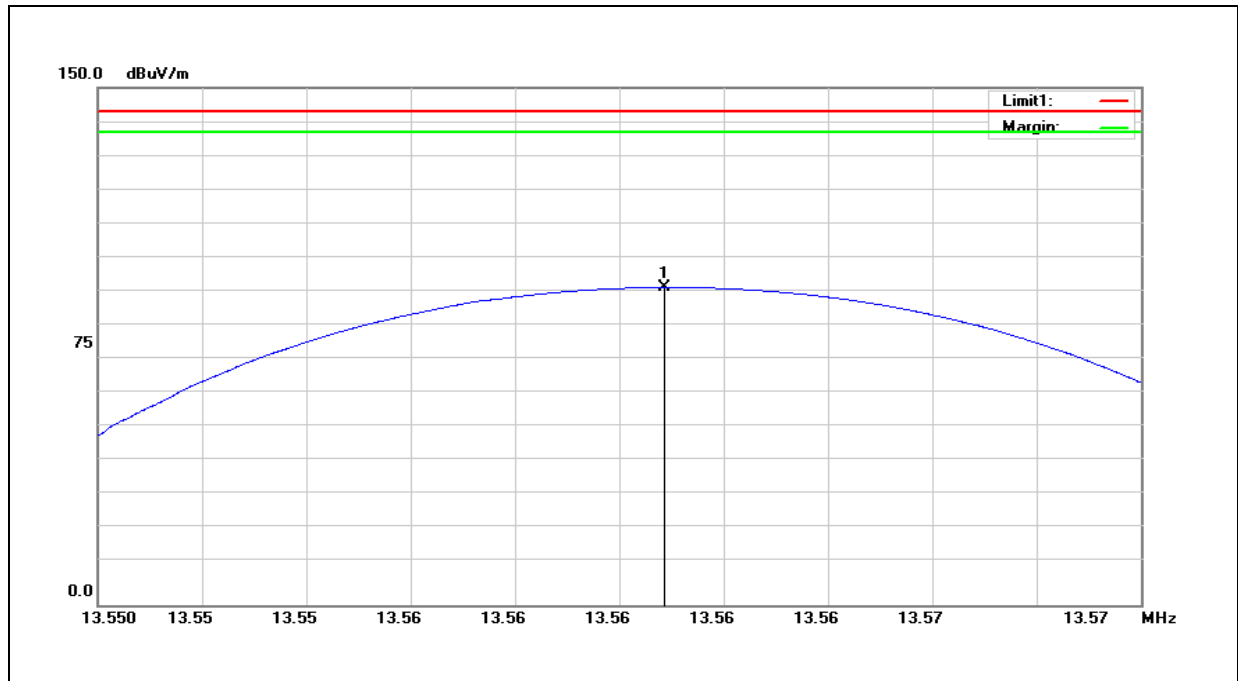

No.	Frequency (MHz)	Reading (dBuV)	Correct Factor (dB/m)	Near-Field Result (dBuV)	Derived Value (dBuV)	Limit (dBuV/m)	Margin (dB)	Remark
1	13.5610	54.29	37.80	92.09	51.62	84.00	-32.38	peak

Note: The level is measured at 1 meter and is converted into result at 30 meter.



9 kHz ~ 30 MHz:

Standard:	FCC Part 15.225	Test Distance:	300/30 m
Test item:	Harmonic	Power:	AC 120 V/60 Hz
Test Mode:	Mode 2	Temp.(°C)/Hum.(%RH):	26(°C)/60 %RH
Ant.Polar.:	Horizontal		

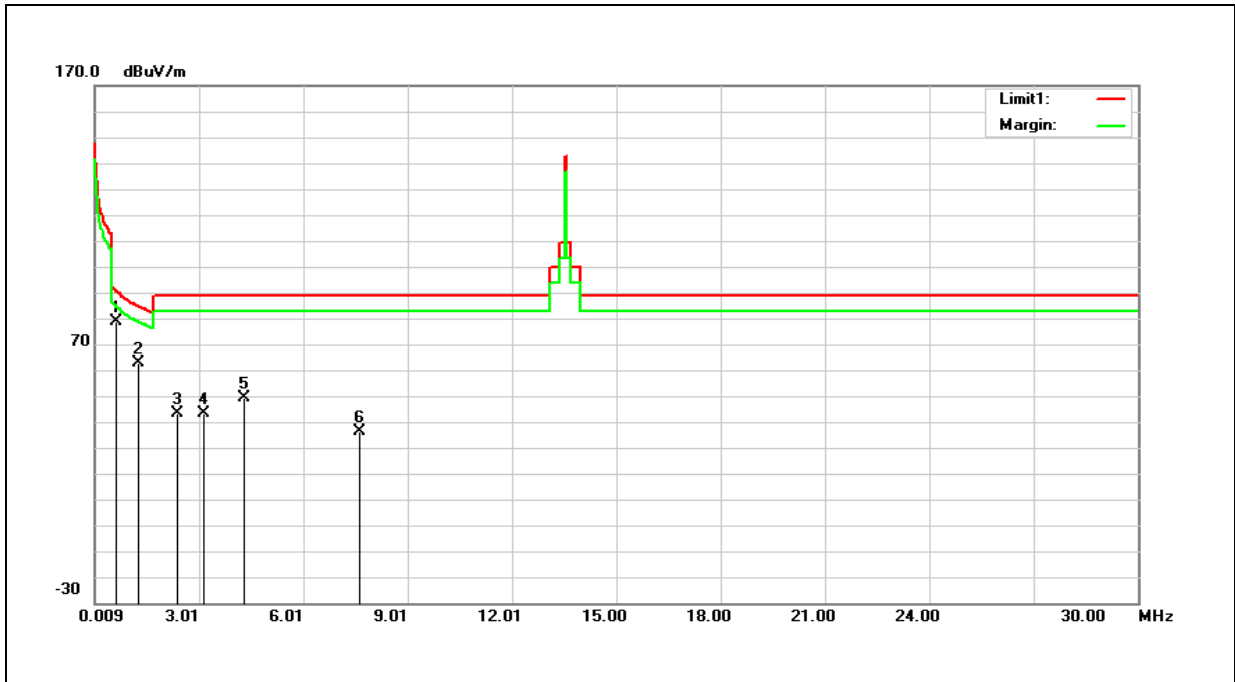

No.	Frequency (MHz)	Reading (dBuV)	Correct Factor (dB/m)	Near-Field Result (dBuV/m)	Derived Value (dBuV)	Limit (dBuV/m)	Margin (dB)	Remark
1	0.6088	34.39	44.31	78.70	11.27	31.91	-20.65	QP
2	1.2686	22.14	40.67	62.81	1.75	25.54	-23.78	QP
3	2.3783	4.88	38.38	43.26	-12.34	29.54	-41.88	QP
4	3.1281	6.24	37.06	43.30	-9.91	29.54	-39.46	QP
5	4.2977	12.08	37.06	49.14	-1.32	29.54	-30.86	QP
6	7.6267	-1.38	37.64	36.26	-9.21	29.54	-38.76	QP

Note: The level is measured at 1 meter and is converted into result at 300 or 30 meter.



Standard:	FCC Part 15.225	Test Distance:	300/30 m
Test item:	Harmonic	Power:	AC 120 V/60 Hz
Test Mode:	Mode 2	Temp.(°C)/Hum.(%RH):	26(°C)/60 %RH
Ant.Polar.:	Vertical		

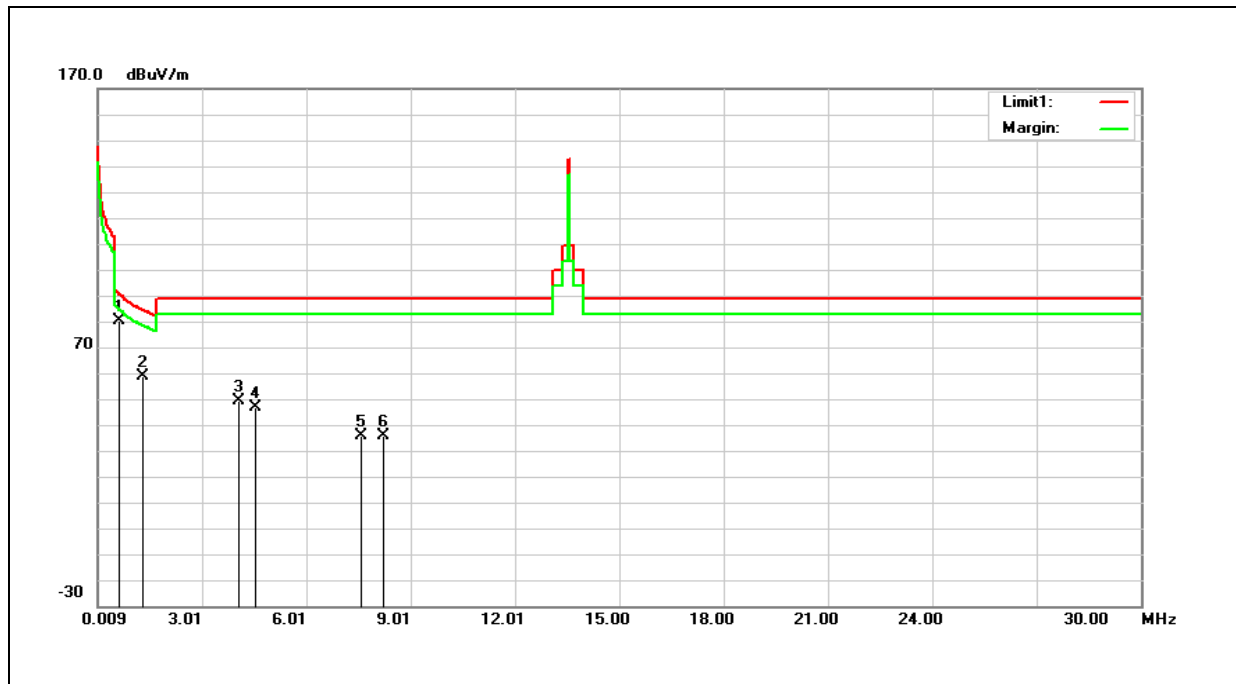

No.	Frequency (MHz)	Reading (dBuV)	Correct Factor (dB/m)	Near-Field Result (dBuV/m)	Derived Value (dBuV)	Limit (dBuV/m)	Margin (dB)	Remark
1	0.6088	36.18	44.31	80.49	13.06	31.91	-18.86	QP
2	1.2986	18.00	40.61	58.61	-2.24	25.33	-27.58	QP
3	4.0577	12.06	37.06	49.12	-1.84	29.54	-31.38	QP
4	4.5376	9.83	37.05	46.88	-3.10	29.54	-32.65	QP
5	7.5967	-1.79	37.63	35.84	-9.68	29.54	-39.22	QP
6	8.2265	-2.14	37.78	35.64	-9.17	29.54	-38.71	QP

Note: The level is measured at 1 meter and is converted into result at 300 or 30 meter.



30 MHz ~ 1 GHz:

Standard:	FCC Part 15.225	Test Distance:	3 m
Test item:	Harmonic	Power:	AC 120 V/60 Hz
Test Mode:	Mode 2	Temp.(°C)/Hum.(%RH):	26(°C)/60 %RH
Ant.Polar.:	Horizontal		

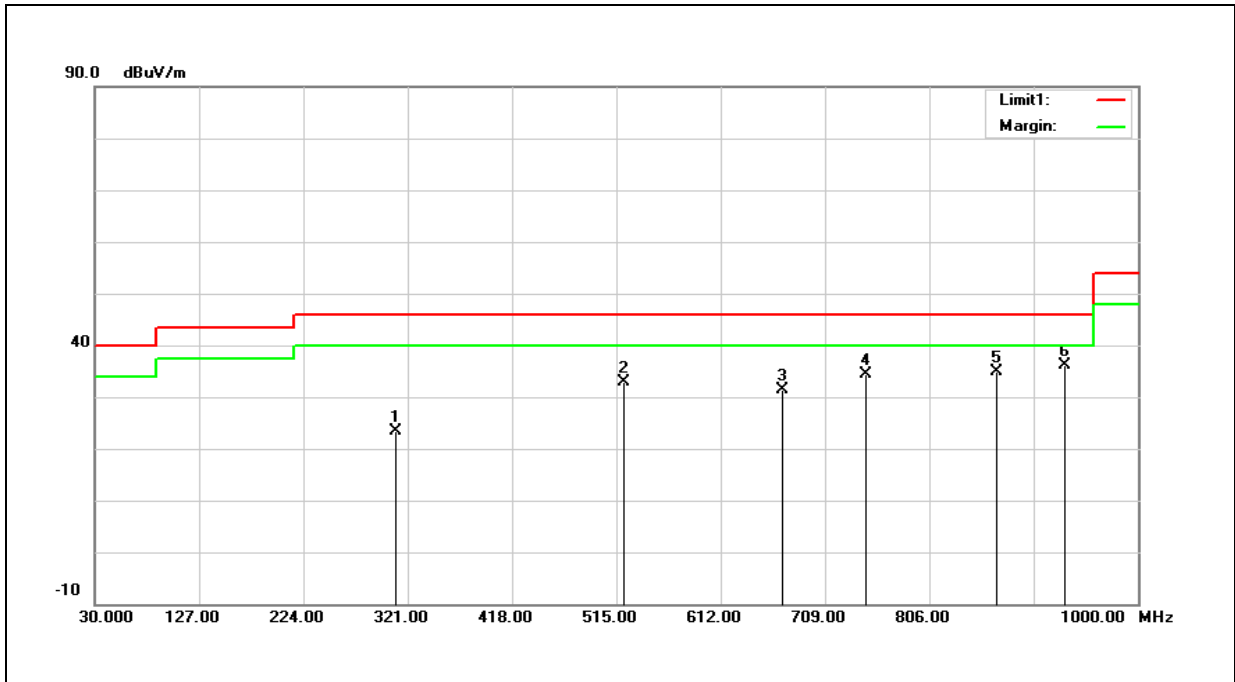

No.	Frequency (MHz)	Reading (dBuV)	Correct Factor (dB/m)	Result (dBuV/m)	Limit (dBuV/m)	Margin (dB)	Remark
1	310.3300	27.01	-3.58	23.43	46.00	-22.57	QP
2	521.7900	32.29	0.58	32.87	46.00	-13.13	QP
3	669.2300	27.70	3.60	31.30	46.00	-14.70	QP
4	746.8300	28.89	5.44	34.33	46.00	-11.67	QP
5	869.0500	27.62	7.30	34.92	46.00	-11.08	QP
6	932.1000	27.64	8.37	36.01	46.00	-9.99	QP



Standard:	FCC Part 15.225	Test Distance:	3 m
Test item:	Harmonic	Power:	AC 120 V/60 Hz
Test Mode:	Mode 2	Temp.(°C)/Hum.(%RH):	26(°C)/60 %RH
Ant.Polar.:	Vertical		

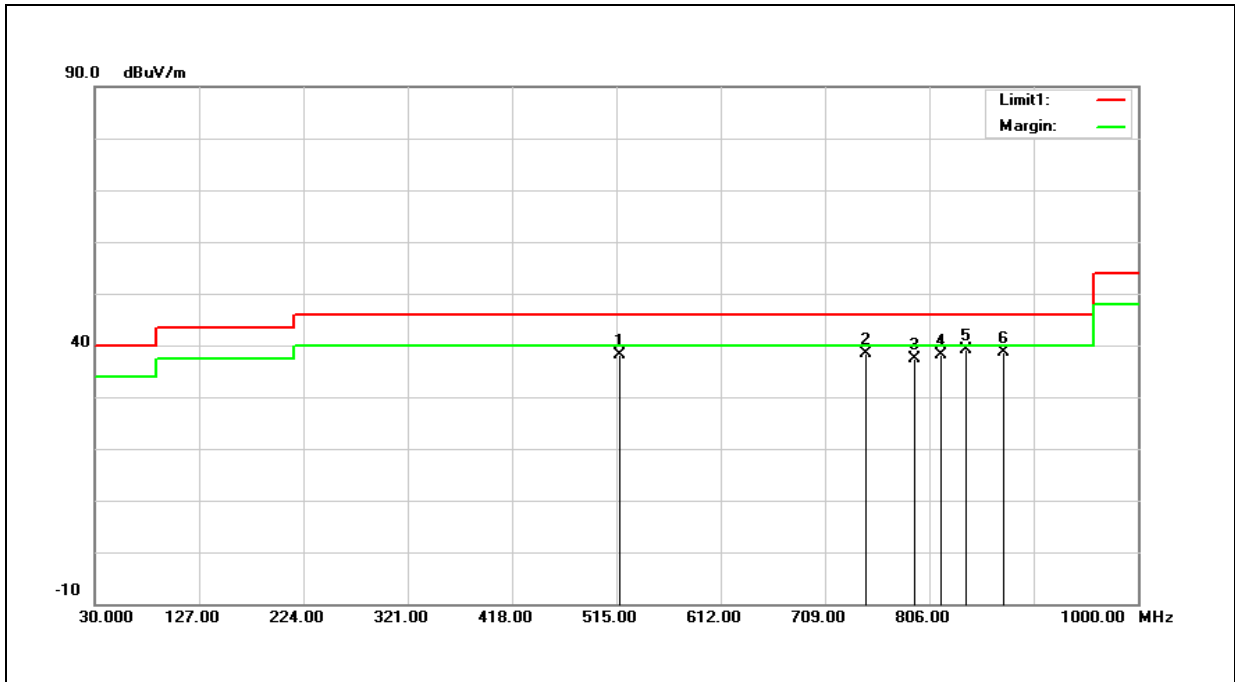

No.	Frequency (MHz)	Reading (dBuV)	Correct Factor (dB/m)	Result (dBuV/m)	Limit (dBuV/m)	Margin (dB)	Remark
1	517.9100	37.62	0.51	38.13	46.00	-7.87	QP
2	746.8300	32.90	5.44	38.34	46.00	-7.66	QP
3	792.4200	31.17	6.23	37.40	46.00	-8.60	QP
4	816.6700	31.48	6.56	38.04	46.00	-7.96	QP
5	839.9500	32.39	6.86	39.25	46.00	-6.75	QP
6	874.8700	31.27	7.39	38.66	46.00	-7.34	QP



Standard:	FCC Part 15.225	Test Distance:	3 m
Test item:	Harmonic	Power:	AC 120 V/60 Hz
Test Mode:	Mode 3	Temp.(°C)/Hum.(%RH):	26(°C)/60 %RH
Ant.Polar.:	Horizontal		

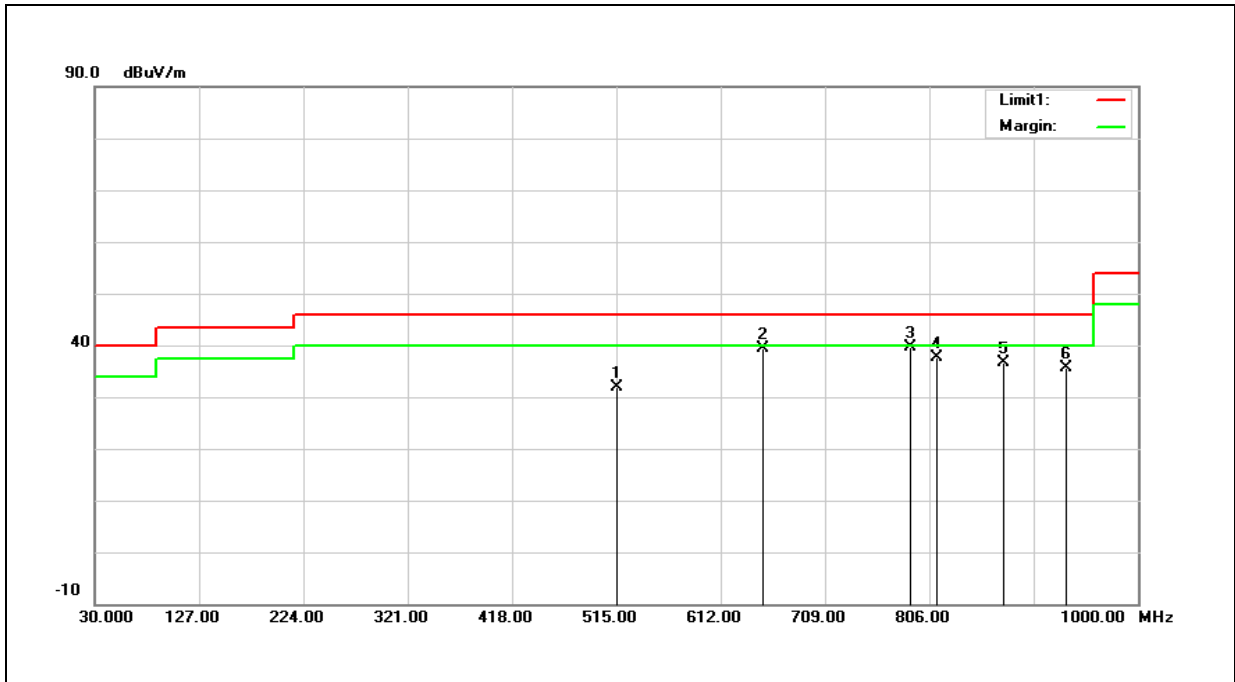

No.	Frequency (MHz)	Reading (dBuV)	Correct Factor (dB/m)	Result (dBuV/m)	Limit (dBuV/m)	Margin (dB)	Remark
1	515.9700	31.42	0.47	31.89	46.00	-14.11	QP
2	650.8000	36.08	3.25	39.33	46.00	-6.67	QP
3	788.5400	33.54	6.17	39.71	46.00	-6.29	QP
4	812.7900	31.04	6.51	37.55	46.00	-8.45	QP
5	874.8700	29.34	7.39	36.73	46.00	-9.27	QP
6	933.0700	27.24	8.39	35.63	46.00	-10.37	QP



Standard:	FCC Part 15.225	Test Distance:	3 m
Test item:	Harmonic	Power:	AC 120 V/60 Hz
Test Mode:	Mode 3	Temp.(°C)/Hum.(%RH):	26(°C)/60 %RH
Ant.Polar.:	Vertical		

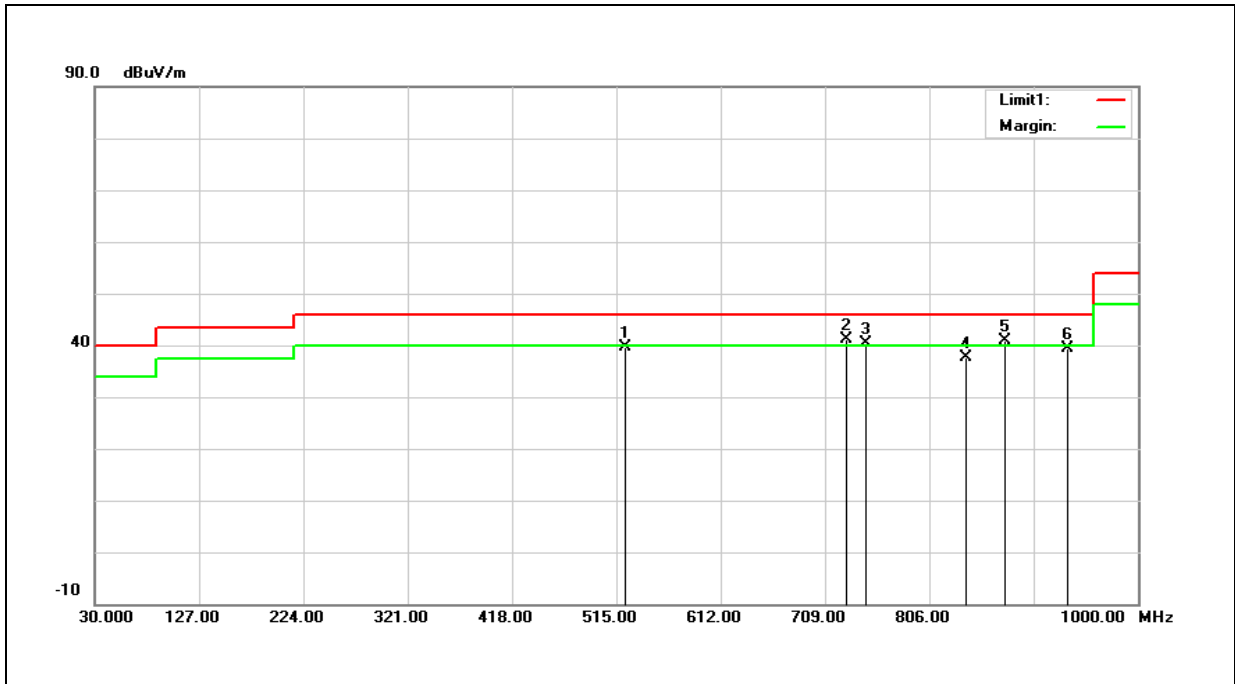

No.	Frequency (MHz)	Reading (dBuV)	Correct Factor (dB/m)	Result (dBuV/m)	Limit (dBuV/m)	Margin (dB)	Remark
1	522.7600	38.96	0.59	39.55	46.00	-6.45	QP
2	729.3700	36.24	4.97	41.21	46.00	-4.79	QP
3	746.8300	34.92	5.44	40.36	46.00	-5.64	QP
4	839.9500	30.83	6.86	37.69	46.00	-8.31	QP
5	875.8400	33.37	7.42	40.79	46.00	-5.21	QP
6	934.0400	30.94	8.40	39.34	46.00	-6.66	QP