

RF Test Report

Applicant : Getac Technology Corporation
Product Name : LN920 radio module
Trade Name : Telit
Model Number : LN920A12-WW
Applicable Standard : FCC 47 CFR PART 22H
FCC 47 CFR PART 24E
FCC 47 CFR PART 27
FCC 47 CFR PART 90S
ANSI C63.26 2015
Received Date : Mar. 27, 2024
Test Period : Apr. 11, 2024 ~ Apr. 12, 2024
Issued Date : May 27, 2024

Issued by

Eurofins E&E Wireless Taiwan Co., Ltd.
No. 140-1, Changan Street, Bade District,
Taoyuan City 334025, Taiwan (R.O.C.)
Tel : +886-3-2710188 / Fax : +886-3-2710190



Taiwan Accreditation Foundation accreditation number: 1330
Frequency Range: 9 kHz to 325 GHz
Bade test site :
Test Firm Registration Number: 226252
Test Firm Designation Number: TW0010
Wugu test site :
Test Firm Registration Number: 191812
Test Firm Designation Number: TW0034

Note:

- 1.The test results are valid only for samples provided by customers and under the test conditions described in this report.
- 2.This report shall not be reproduced except in full, without the written approval of Eurofins E&E Wireless Taiwan Co., Ltd.
- 3.The relevant information is provided by customers in this test report. According to the correctness, appropriateness or completeness of the information provided by the customer, if there is any doubt or error in the information which affects the validity of the test results, the laboratory does not take the responsibility.

Revision History

Rev.	Issued Date	Description	Revised by
00	May 27, 2024	Initial Issue	Snow Wang

Verification of Compliance

Applicant : Getac Technology Corporation

Product Name : LN920 radio module

Trade Name : Telit

Model Number : LN920A12-WW

FCC ID : QYLLN920U

Applicable Standard : FCC 47 CFR PART 22H
FCC 47 CFR PART 24E
FCC 47 CFR PART 27
FCC 47 CFR PART 90S
ANSI C63.26 2015

Test Result : Complied

Performing Lab. : Eurofins E&E Wireless Taiwan Co., Ltd.
No. 140-1, Changan Street, Bade District,
Taoyuan City 334025, Taiwan (R.O.C.)
Tel : +886-3-2710188 / Fax : +886-3-2710190
Taiwan Accreditation Foundation accreditation number: 1330



Eurofins E&E Wireless Taiwan Co., Ltd. tested the above equipment in accordance with the requirements set forth in the above standards. All indications of Pass/Fail in this report are opinions expressed by Eurofins E&E Wireless Taiwan Co., Ltd. based on interpretations and/or observations of test results. The test results show that the equipment tested is capable of demonstrating compliance with the requirements as documented in this report.

Approved By : Kai Yu Yang

TABLE OF CONTENTS

1	General Information.....	5
1.1.	Summary of Test Result.....	5
1.2.	Testing Location.....	6
1.3.	Measurement Uncertainty.....	6
1.4.	Test Site Environment.....	6
2	EUT Description.....	7
2.1.	Mode of Operation.....	9
2.2.	EUT Test Step.....	9
2.3.	Configuration of Test System Details.....	9
2.4.	Test Instruments.....	10
3	Measurement Procedure.....	11
3.1.	Radiated Emission Test.....	11
4	Test Results.....	13
4.1.	Radiated Emission.....	13

Appendix A. Test Setup Photographs

1 General Information

1.1. Summary of Test Result

FCC Rule	Description	Result
§2.1046	Conducted Output Average Power	N/A (Note 1)
§22.913 §24.232 §27.50 §90.542(Part 90R) §90.635(Part 90S) §96.41(b)	Equivalent Isotropic Radiated Power / Equivalent Radiated Power	N/A (Note 1)
§2.1055 §22.355 §24.235 §27.54	Frequency Stability	N/A (Note 1)
§2.1049	Emission Bandwidth & Occupied Bandwidth	N/A (Note 1)
§24.232 §27.50 §96.41(g)	Peak to average power ratio	N/A (Note 1)
§2.1051 §22.917 §24.238 §27.53 §90.543(Part 90R) §96.41(e)	Band Edge	N/A (Note 1)
§2.1051 §22.917 §24.238 §27.53 §90.543(Part 90R) §96.41(e)	Conducted Spurious Emissions	N/A (Note 1)
§2.1053 §22.917 §24.238 §27.53 §90.543(Part 90R) §96.41(e)	Radiated Spurious Emissions	Pass (Note 2)

Note 1: No need for verification.

Note 2: Only verify the Simultaneous Transmission.

Decision Rule

- Uncertainty is not included.
- Uncertainty is included.

1.2. Testing Location

Lab Name: Eurofins E&E Wireless Taiwan Co., Ltd.

Site Address: No. 140-1, Changan Street, Bade District, Taoyuan City 334025, Taiwan (R.O.C.)

Site Address: No. 2, Wuquan 5th Rd. Wugu Dist., New Taipei City, Taiwan (R.O.C.)

1.3. Measurement Uncertainty

Parameter	Uncertainty			
	96601-BD	96603-BD	96602-WG	96603-WG
Radiated Emission	4.9 dB	4.9 dB	4.9 dB	4.9 dB

1.4. Test Site Environment

Items	Required (IEC 68-1)	Interval(*)
Temperature (°C)	15-35	20-30
Humidity (%RH)	25-75	45-75
Barometric pressure (mbar)	860-1060	990-1005

(*)The measurement ambient temperature is within this range.

2 EUT Description

The product specifications of the EUT presented in the report are declared by the manufacturer who shall take full responsibility for the authenticity(except E.R.P. /E.I.R.P., Occupied Bandwidth, Emission Designator).

Applicant	Getac Technology Corporation 5F., Building A, No. 209, Sec. 1, Nangang Rd., Nangang Dist., Taipei City, 115018, Taiwan		
Product Name	LN920 radio module		
Trade Name	Telit		
Model Number	LN920A12-WW		
FCC ID	QYLLN920U		
Host Information	Product Name: Tablet Trade Name: Getac Model Name: UX10, UX10G3, UX10-301, UX10-321, UX10-Ex, UX10G4, UX10Y(Y= 10 characters, Y can be 0 to 9, A to Z, a to z, "/", "\", "-", "_ " or blank for marketing purpose) (All models are electrically identical, different model names are for marketing purpose.)		
Hardware Version	1.1		
Software Version / Firmware Version	M0L.00002		
IMEI No.	358989890008768		
Operate Band	Frequency Range (MHz)	Modulation	Channel Bandwidth
LTE Band 2	UL: 1850 ~ 1910	QPSK, 16QAM, 64QAM, 256QAM	1.4 MHz, 3 MHz, 5 MHz, 10 MHz, 15 MHz, 20 MHz
	DL: 1930 ~ 1990		
LTE Band 4	UL: 1710 ~ 1755		1.4 MHz, 3 MHz, 5 MHz, 10 MHz, 15 MHz, 20 MHz
	DL: 2110 ~ 2155		
LTE Band 5	UL: 824 ~ 849		1.4 MHz, 3 MHz, 5 MHz, 10 MHz
	DL: 869 ~ 894		
LTE Band 7	UL: 2500 ~ 2570		5 MHz, 10 MHz, 15 MHz, 20 MHz
	DL: 2620 ~ 2690		
LTE Band 12	UL: 699 ~ 716		1.4 MHz, 3 MHz, 5 MHz, 10 MHz
	DL: 728 ~ 746		
LTE Band 13	UL: 777 ~ 787		5 MHz, 10 MHz
	DL: 746 ~ 756		
LTE Band 14	UL: 788 ~ 798		5 MHz, 10 MHz
	DL: 758 ~ 768		
LTE Band 25	UL: 1850 ~ 1915		1.4 MHz, 3 MHz, 5 MHz, 10 MHz, 15 MHz, 20 MHz
	DL: 1930 ~ 1995		
LTE Band 26	UL: 824 ~ 849	1.4 MHz, 3 MHz, 5 MHz, 10 MHz, 15 MHz	
	DL: 869 ~ 894		
LTE Band 30(RX only)	DL: 2305 ~ 2315	5 MHz, 10 MHz	
LTE Band 38	UL/DL: 2500 ~ 2690	5 MHz, 10 MHz, 15 MHz, 20 MHz	

Operate Band	Frequency Range (MHz)	Modulation	Channel Bandwidth	
LTE Band 41	UL/DL: 2500 ~ 2690	QPSK, 16QAM, 64QAM, 256QAM	5 MHz, 10 MHz, 15 MHz, 20 MHz	
LTE Band 48	UL/DL: 3450 ~ 3900		5 MHz, 10 MHz, 15 MHz, 20 MHz	
	UL/DL: 3650 ~ 3700		5 MHz, 10 MHz, 15 MHz, 20 MHz	
LTE Band 66	UL: 1710 ~ 1780		1.4 MHz, 3 MHz, 5 MHz, 10 MHz, 15 MHz, 20 MHz	
	DL: 2110 ~ 2200			
LTE Band 71	UL: 663 ~ 698		5 MHz, 10 MHz, 15 MHz, 20 MHz	
	DL: 617 ~ 652			
Antenna information	Type	Max. Gain (dBi)		
	PIFA Antenna	LTE Band 2	2.5	
		LTE Band 4	3.0	
		LTE Band 5	0.8	
		LTE Band 7	2.8	
		LTE Band 12	1.8	
		LTE Band 13	1.1	
		LTE Band 14	1.1	
		LTE Band 25	2.4	
		LTE Band 26	1	
		LTE Band 38	2.8	
		LTE Band 41	2.8	
		LTE Band 48	0.5	
		LTE Band 66	2.7	
LTE Band 71	-2.5			
Operate Temp. Range	15 ~ 35 °C			
EUT Power Rating	DC 3.3 V			

EUT Modify Description :

Modify Description:
 1.Add host model: UX10, UX10G3, UX10-301, UX10-321, UX10-Ex, UX10G4, UX10Y(Y= 10 characters, Y can be 0 to 9, A to Z, a to z, “/”, “\”, “-”, “_” or blank for marketing purpose).
 2.Change antenna.

After replacing the antenna, the Gain is smaller than the original antenna.
 After Our evaluation, the retest of Radiated Emissions Below 1GHz and Simultaneous Transmitter of Spurious Radiated are required.
 The other test data refer to the original report

2.1. Mode of Operation

Eurofins has verified the construction and function in typical operation. All the test modes were carried out with the EUT in normal operation, which was shown in this test report and defined as:

Test Mode
Co-location

2.2. EUT Test Step

1	Setup the EUT shown on "Configuration of Test System Details".
2	Turn on the power of all equipment.

2.3. Configuration of Test System Details

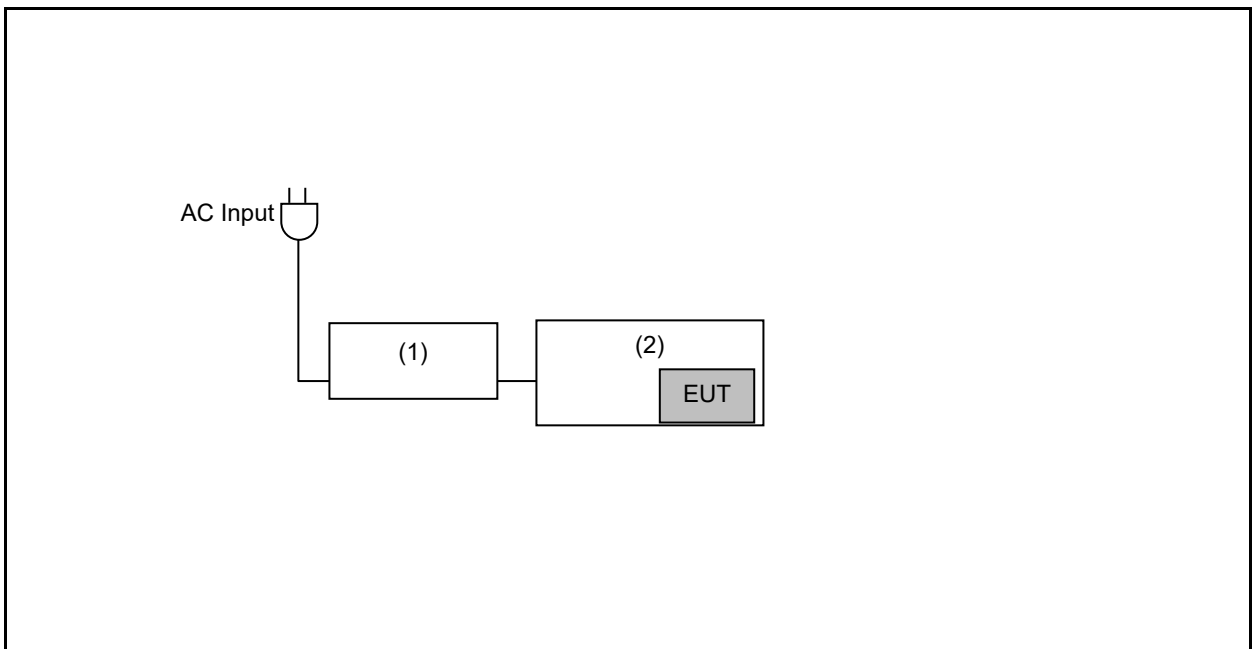

Devices Description					
	Product	Manufacturer	Model Number	Serial Number	Power Cord
(1)	Adapter	Chicony	A20-065N3A	---	---
(2)	Tablet	Getac	UX10G4	---	---

2.4. Test Instruments

For Radiated Emissions

Test Period: Apr. 11 ~ Apr. 12, 2024

Testing Engineer: Marin Lee

Radiation test sites		Semi Anechoic Room 96602-WG				
Use	Equipment	Manufacturer	Model Number	Serial Number	Cal. Date	Cal. Period
<input checked="" type="checkbox"/>	LOOP Antenna (9 kHz~30 MHz)	Schwarzbeck Mess-Elektronik	FMZB 1513-60	00031	Feb. 23, 2024	1 year
<input checked="" type="checkbox"/>	Broadband Horn Antenna (1 GHz~18 GHz)	RF SPIN	DRH18-E	210305A18ES	Feb. 22, 2024	1 year
<input checked="" type="checkbox"/>	Broadband Horn Antenna (15 GHz~40 GHz)	Schwarzbeck Mess-Elektronik	BBHA9170	01133	Jan. 18, 2024	1 year
<input checked="" type="checkbox"/>	Spectrum Analyzer (10 Hz~44 GHz)	KEYSIGHT	N9020B	MY60112362	Jan. 29, 2024	1 year
<input checked="" type="checkbox"/>	Radio Communication Analyzer	Anritsu	MT8821C	6272459653	Aug. 16, 2023	1 year
<input checked="" type="checkbox"/>	Pre-Amplifier	Agilent	8447D	2944A10961	Jul. 10, 2023	1 year
<input checked="" type="checkbox"/>	Pre-Amplifier	EMCI	EMC118A45SE	980822	Nov. 29, 2023	1 year
<input checked="" type="checkbox"/>	Pre-Amplifier	EMCI	EMC184045SE	980861	Dec. 21, 2023	1 year
<input checked="" type="checkbox"/>	Coaxial Cable (10 kHz~3000 MHz)	EMCI	EMCCFD400-NM-NM-2000	211006	Nov. 13, 2023	1 year
<input checked="" type="checkbox"/>	Coaxial Cable (10 kHz~3000 MHz)	EMCI	EMCCFD400-NM-NM-2000	211007	Nov. 13, 2023	1 year
<input checked="" type="checkbox"/>	Coaxial Cable (10 kHz~3000 MHz)	EMCI	EMCCFD400-NM-NM-6000	211015	Nov. 13, 2023	1 year
<input checked="" type="checkbox"/>	Coaxial Cable (1 GHz~18 GHz)	EMCI	EMC104-SM-SM-1000	211026	Nov. 13, 2023	1 year
<input checked="" type="checkbox"/>	Coaxial Cable (1 GHz~18 GHz)	EMCI	EMC104-SM-SM-2000	211035	Nov. 13, 2023	1 year
<input checked="" type="checkbox"/>	Coaxial Cable (1 GHz~18 GHz)	EMCI	EMC104-SM-SM-8000	211036	Nov. 13, 2023	1 year
<input checked="" type="checkbox"/>	Coaxial Cable (18 GHz~40 GHz)	EMCI	EMC101G-KM-KM-600	211211	Jan. 16, 2024	1 year
<input checked="" type="checkbox"/>	Coaxial Cable (18 GHz~40 GHz)	EMCI	EMC101G-KM-KM-2000	211210	Jan. 16, 2024	1 year
<input checked="" type="checkbox"/>	Coaxial Cable (18 GHz~40 GHz)	EMCI	EMC101G-KM-KM-6000	211209	Jan. 16, 2024	1 year
<input checked="" type="checkbox"/>	Highpass Filter	Warison	WFIL-H8000-26000F	001	Nov. 13, 2023	1 year
<input checked="" type="checkbox"/>	Software	R_RAM	V1.3	N/A	N.C.R.	---

Note: N.C.R. = No Calibration Request

3 Measurement Procedure

3.1. Radiated Emission Test

■ Limit

The power of any emission outside a licensee's frequency block shall be attenuated below the transmitter power (P) by at least $43 + 10 \log_{10}(P)$ dB. The limit of emission equal to -13 dBm

■ Setup

Below 1 GHz

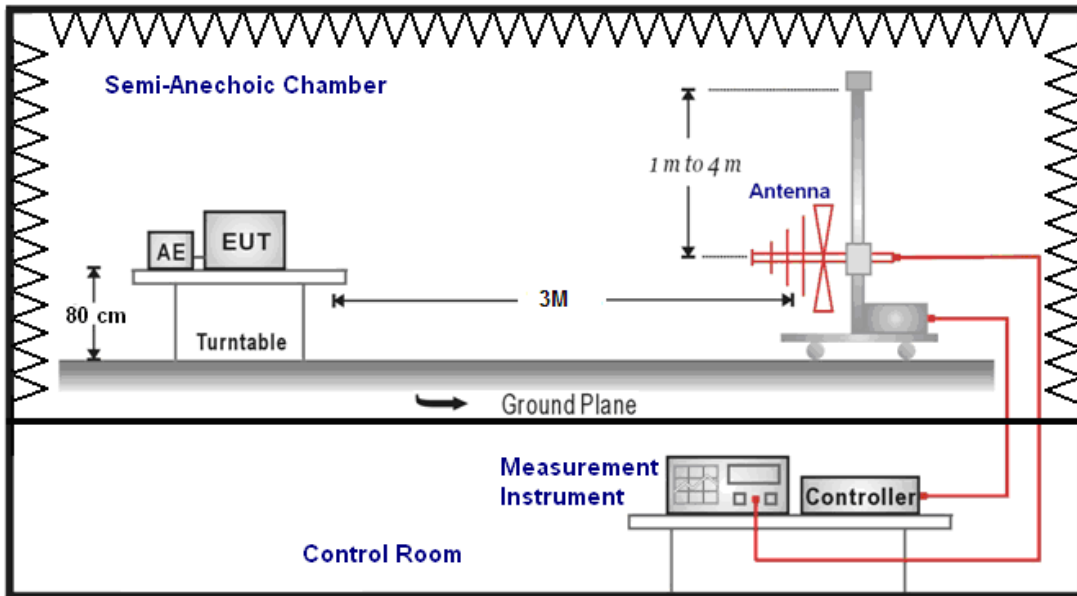

Above 1 GHz

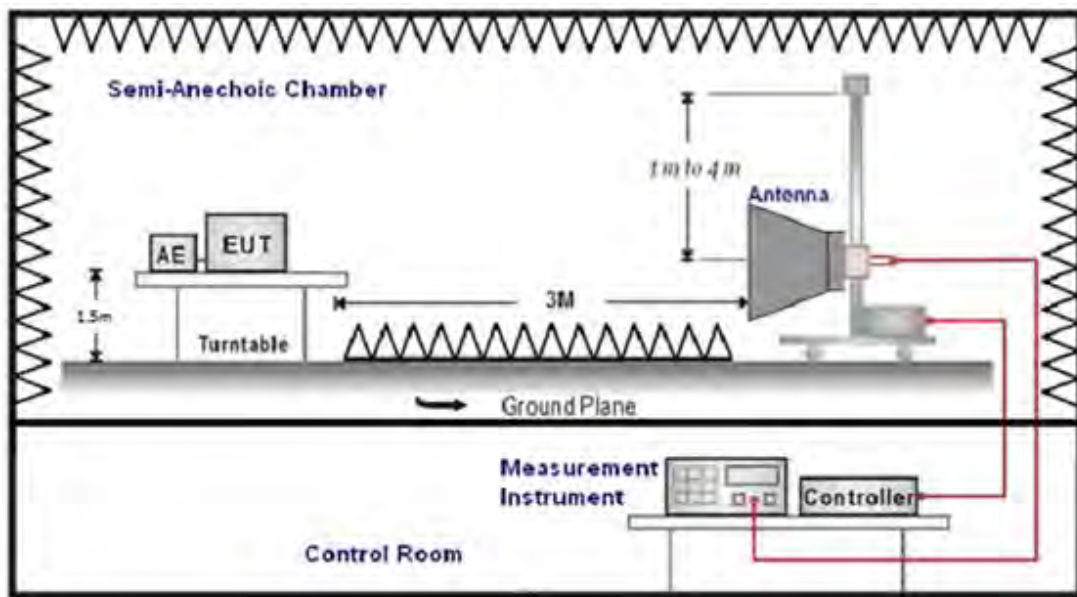

For Substituted Method Test Set-UP

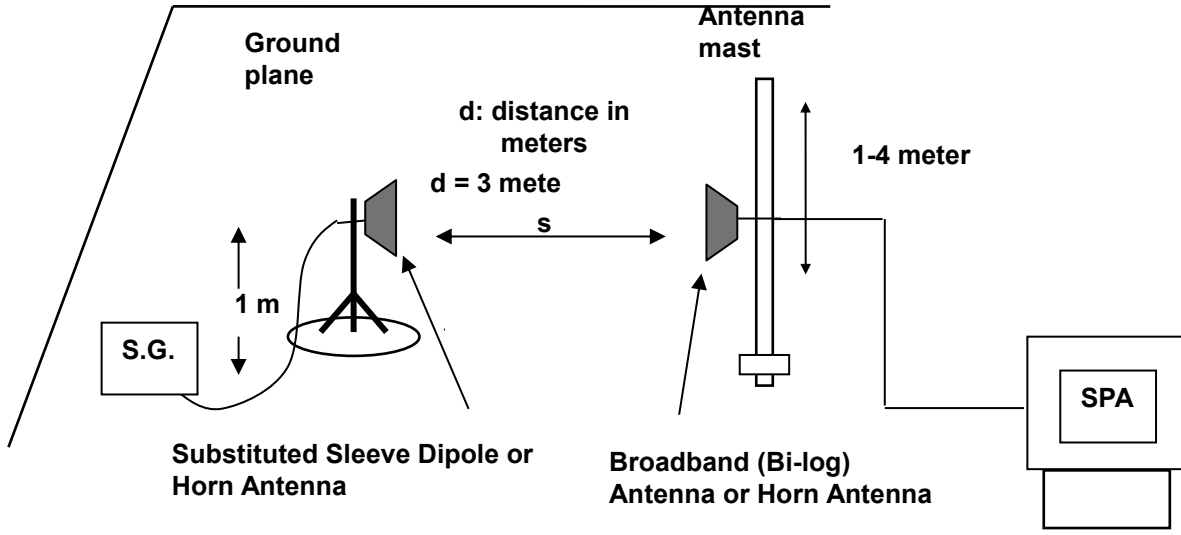

■ Test Procedure

- The EUT was set up for the maximum power with WWAN link data modulation. The power was measured with Spectrum Analyzer. All measurements were done at 3 channels (low, middle and high operational frequency range).
- Radiation Emission measurement. In the semi-anechoic chamber, EUT placed on the 0.8 m (1.5 m for above 1 GHz) height of Turn Table, rotated the table around 360 degrees to search the maximum radiation power and receiver antenna shall be rotated vertical and horizontal polarization and moved height from 1 m to 4 m to find the maximum polar radiated power. The "Read Value" is the spectrum reading the maximum power value.
- The substitution antenna (Note:1 & 2) is substituted for EUT at the same position and signals generator export the CW signal to the substitution antenna via a TX cable. Rotated the Turn Table and moved receiving antenna to find the maximum radiation power. Adjust output power level of S.G to get a Value of spectrum reading equal to "Read Value" of step a. Record the power level of S.G.
- $E.I.R.P. = \text{Output power level of S.G} - \text{TX cable loss} + \text{Antenna gain of substitution horn}$
- $E.R.P. = E.I.R.P. - 2.15 \text{ dB}$
- Measurement range 9 kHz - 10 th Harmonic

Note: 1. Below 1 GHz Substituted Method Test : Sleeve dipole antenna to Bi-Log Antenna

2. Above 1 GHz Substituted Method Test : Horn antenna to Horn Antenna

4 Test Results

4.1. Radiated Emission

Test Site:	96602 - WG	Standard:	Part 22_24_27_90_96
Test Mode:	Normal Operation		
Polarization:	Horizontal		
Remark:			

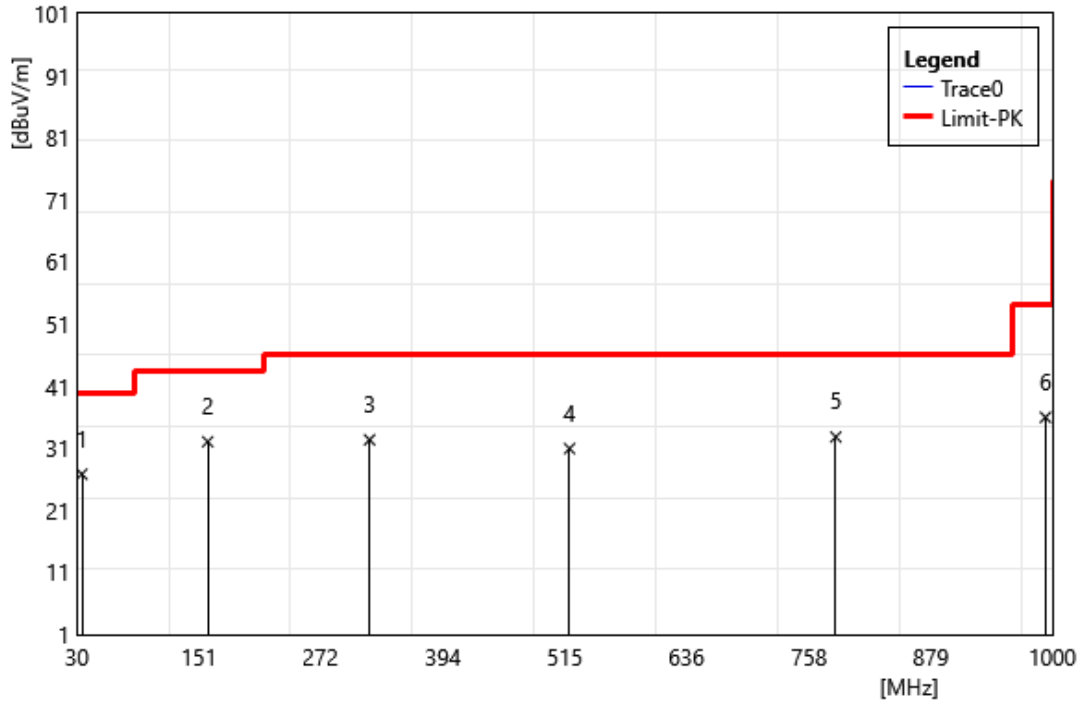

ID	Frequency MHz	Reading dBuV	Correct Factor dB/m	Result dBuV/m	Limit dBuV/m	Margin dB	Remark
1	34.85	35.69	-8.86	26.83	40.00	-13.17	QP
2	159.98	39.49	-7.43	32.06	43.50	-11.44	QP
3	321.00	38.36	-6.00	32.36	46.00	-13.64	QP
4	519.85	33.84	-2.89	30.95	46.00	-15.05	QP
5	784.66	30.67	2.15	32.82	46.00	-13.18	QP
6	993.21	30.41	5.57	35.98	54.00	-18.02	QP

Test Site:	96602 - WG	Standard:	Part 22_24_27_90_96
Test Mode:	Normal Operation		
Polarization:	Vertical		
Remark:			

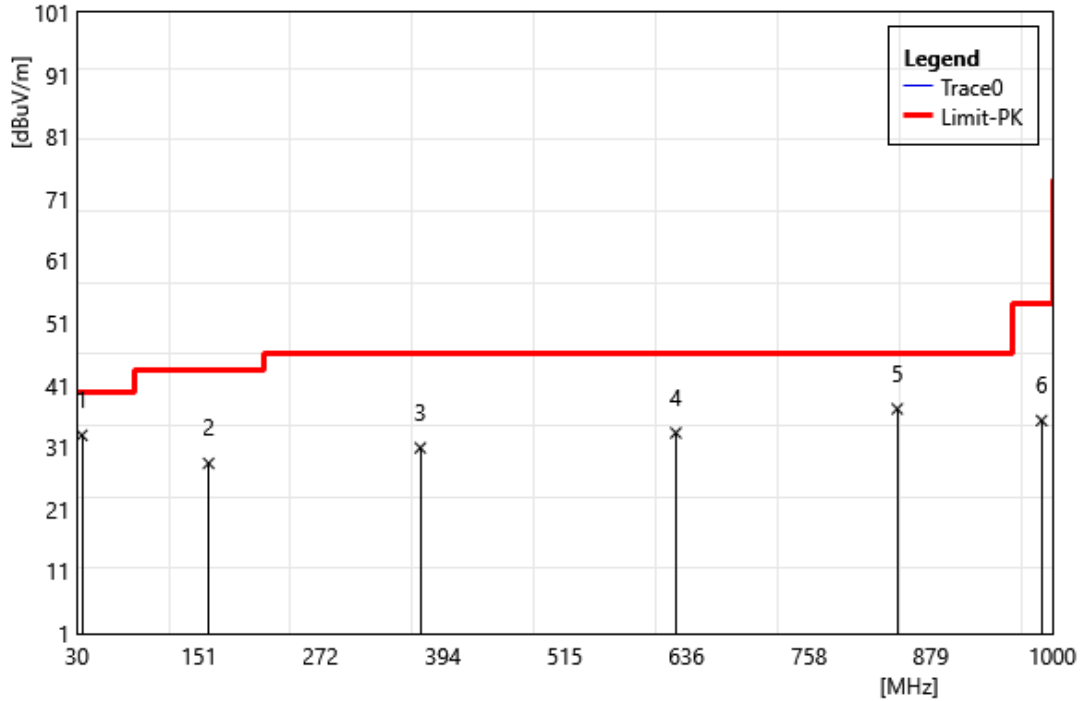

ID	Frequency MHz	Reading dBuV	Correct Factor dB/m	Result dBuV/m	Limit dBuV/m	Margin dB	Remark
1	34.85	41.78	-8.86	32.92	40.00	-7.08	QP
2	160.95	35.82	-7.41	28.41	43.50	-15.09	QP
3	371.44	36.17	-5.28	30.90	46.00	-15.11	QP
4	625.58	33.96	-0.65	33.31	46.00	-12.69	QP
5	845.77	34.13	3.06	37.19	46.00	-8.81	QP
6	989.33	29.84	5.47	35.31	54.00	-18.69	QP

Test Site:	96602-WG	Standard:	Part 22_24_27_90_96
Test Mode:	LTE+BT+2.4G		
Polarization:	Horizontal		
Remark:			

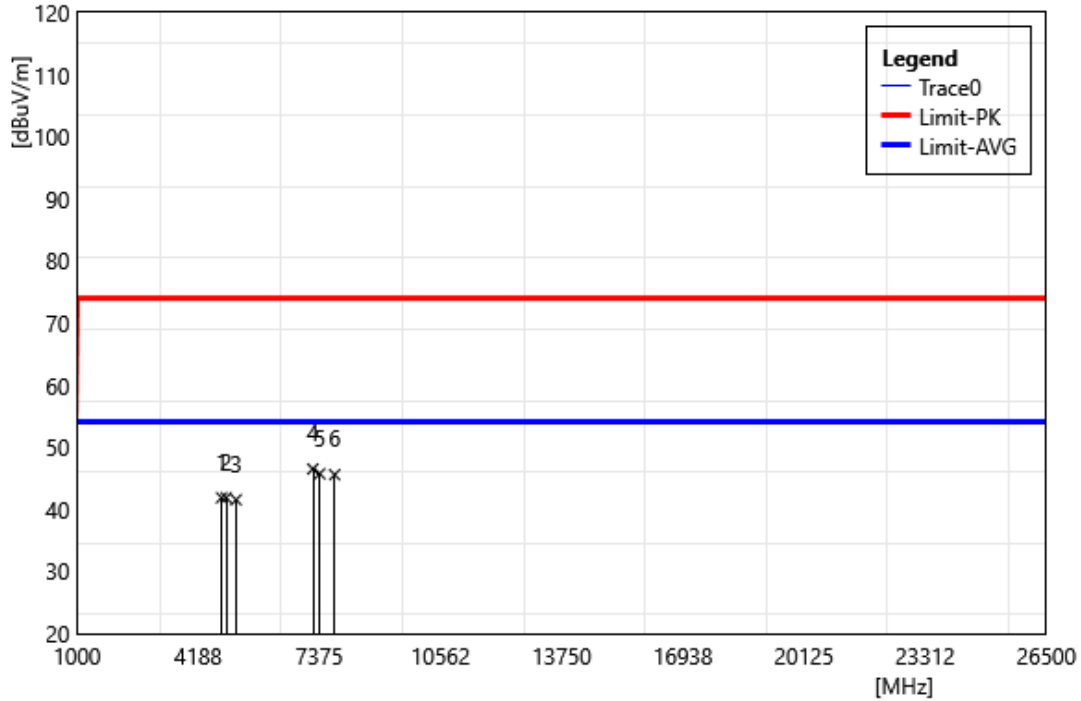

ID	Frequency MHz	Reading dBuV	Correct Factor dB/m	Result dBuV/m	Limit dBuV/m	Margin dB	Remark
1	4804.00	40.56	1.30	41.86	74.00	-32.14	PEAK
2	4924.00	40.51	1.35	41.86	74.00	-32.14	PEAK
3	5186.00	39.98	1.57	41.55	74.00	-32.45	PEAK
4	7206.00	40.23	6.27	46.50	74.00	-27.50	PEAK
5	7386.00	39.47	6.26	45.73	74.00	-28.27	PEAK
6	7779.00	39.36	6.23	45.59	74.00	-28.41	PEAK

Test Site:	96602-WG	Standard:	Part 22_24_27_90_96
Test Mode:	LTE+BT+2.4G		
Polarization:	Vertical		
Remark:			

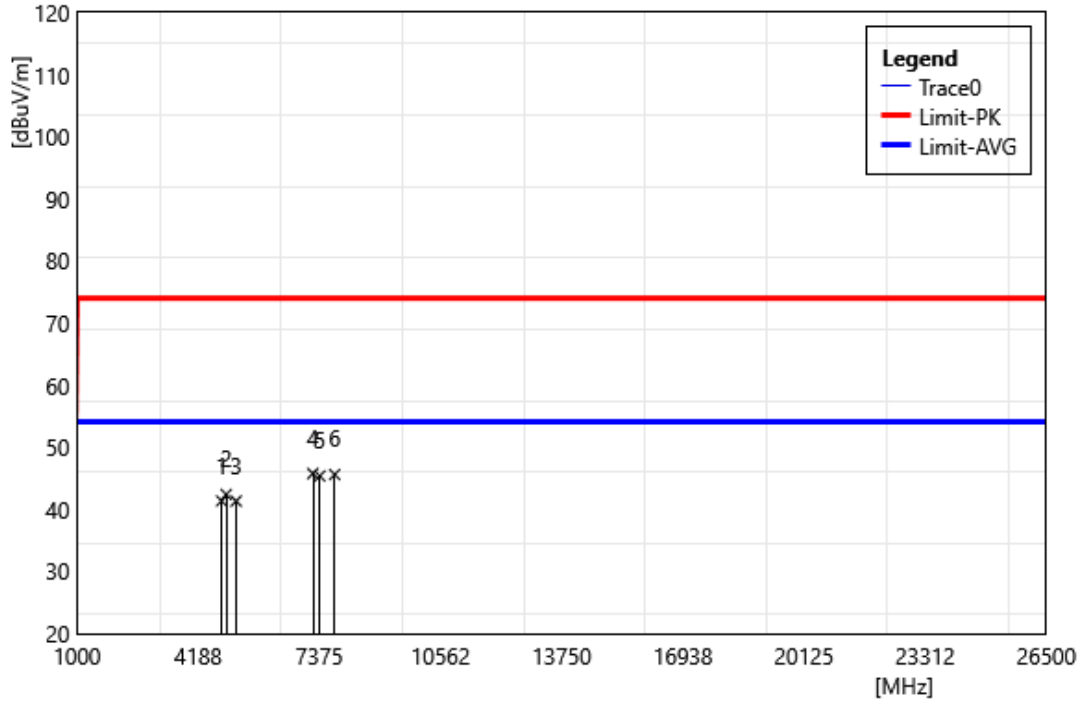

ID	Frequency MHz	Reading dBuV	Correct Factor dB/m	Result dBuV/m	Limit dBuV/m	Margin dB	Remark
1	4804.00	40.05	1.30	41.35	74.00	-32.65	PEAK
2	4924.00	41.05	1.35	42.40	74.00	-31.60	PEAK
3	5186.00	39.76	1.57	41.33	74.00	-32.67	PEAK
4	7206.00	39.49	6.27	45.76	74.00	-28.24	PEAK
5	7386.00	39.12	6.26	45.38	74.00	-28.62	PEAK
6	7779.00	39.37	6.23	45.60	74.00	-28.40	PEAK

Test Site:	96602-WG	Standard:	Part 22_24_27_90_96
Test Mode:	LTE+BT+5G		
Polarization:	Horizontal		
Remark:			

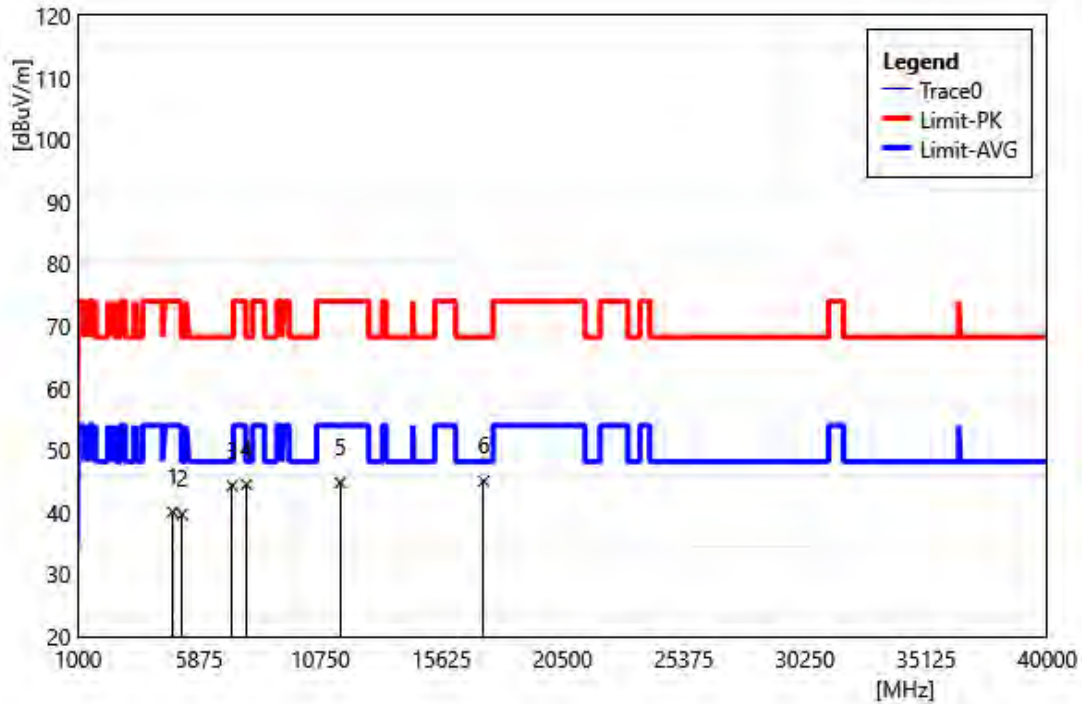

ID	Frequency MHz	Reading dBuV	Correct Factor dB/m	Result dBuV/m	Limit dBuV/m	Margin dB	Remark
1	4804.00	38.75	1.30	40.05	74.00	-33.95	PEAK
2	5186.00	38.09	1.57	39.66	68.20	-28.54	PEAK
3	7206.00	38.03	6.27	44.30	68.20	-23.90	PEAK
4	7779.00	38.27	6.23	44.50	68.20	-23.70	PEAK
5	11550.00	37.75	7.02	44.77	74.00	-29.23	PEAK
6	17325.00	38.48	6.55	45.03	68.20	-23.17	PEAK

Test Site:	96602-WG	Standard:	Part 22_24_27_90_96
Test Mode:	LTE+BT+5G		
Polarization:	Vertical		
Remark:			

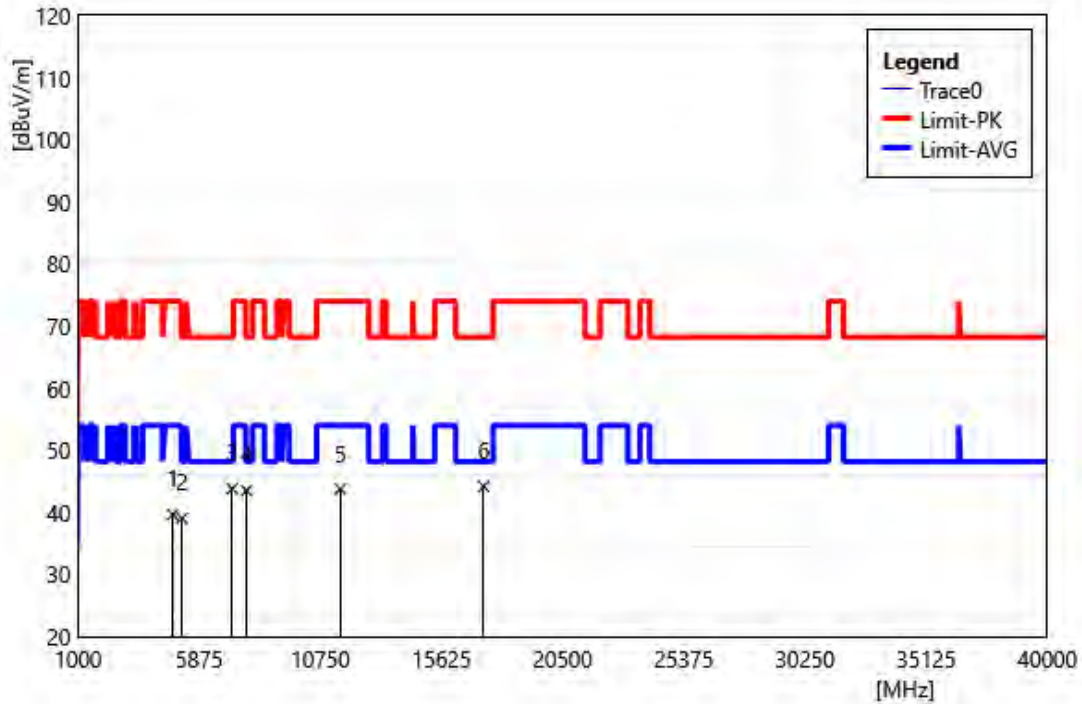

ID	Frequency MHz	Reading dBuV	Correct Factor dB/m	Result dBuV/m	Limit dBuV/m	Margin dB	Remark
1	4804.00	38.35	1.30	39.65	74.00	-34.35	PEAK
2	5186.00	37.46	1.57	39.03	68.20	-29.17	PEAK
3	7206.00	37.53	6.27	43.80	68.20	-24.40	PEAK
4	7779.00	37.28	6.23	43.51	68.20	-24.69	PEAK
5	11550.00	36.74	7.02	43.76	74.00	-30.24	PEAK
6	17325.00	37.64	6.55	44.19	68.20	-24.01	PEAK

Test Site:	96602-WG	Standard:	Part 22_24_27_90_96
Test Mode:	LTE+BT+6E		
Polarization:	Horizontal		
Remark:			

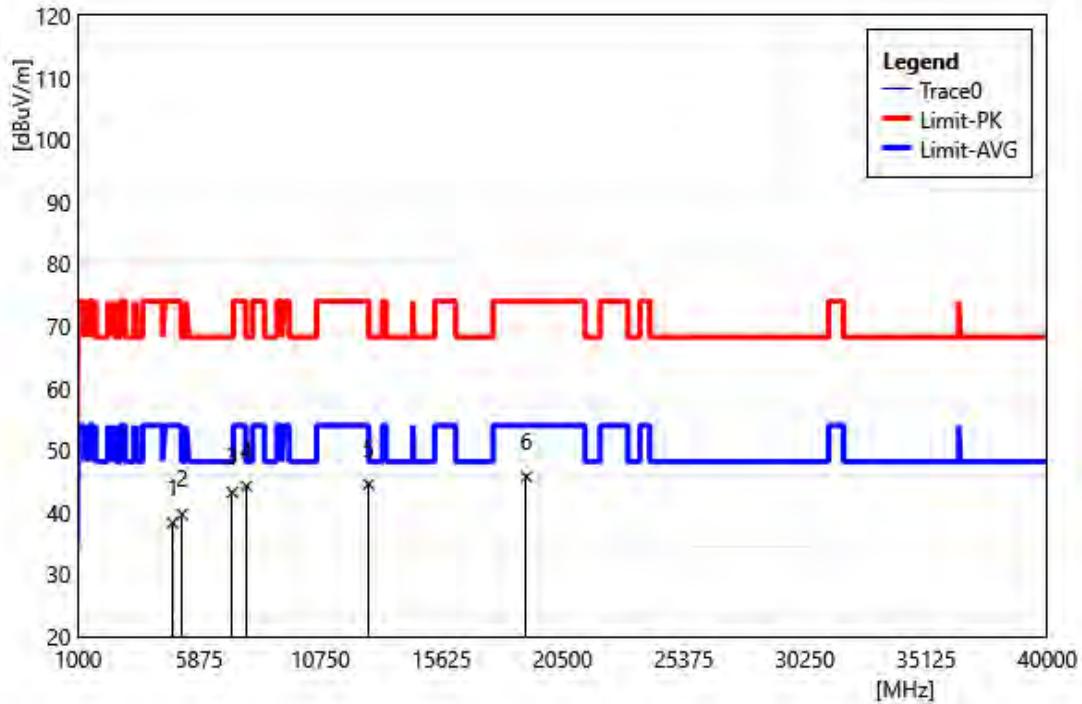

ID	Frequency MHz	Reading dBuV	Correct Factor dB/m	Result dBuV/m	Limit dBuV/m	Margin dB	Remark
1	4804.00	37.00	1.30	38.30	74.00	-35.70	PEAK
2	5186.00	38.09	1.57	39.66	68.20	-28.54	PEAK
3	7206.00	36.93	6.27	43.20	68.20	-25.00	PEAK
4	7779.00	37.98	6.23	44.21	68.20	-23.99	PEAK
5	12690.00	36.61	7.93	44.54	74.00	-29.46	PEAK
6	19035.00	38.30	7.47	45.77	74.00	-28.23	PEAK

Test Site:	96602-WG	Standard:	Part 22_24_27_90_96
Test Mode:	LTE+BT+6E		
Polarization:	Vertical		
Remark:			

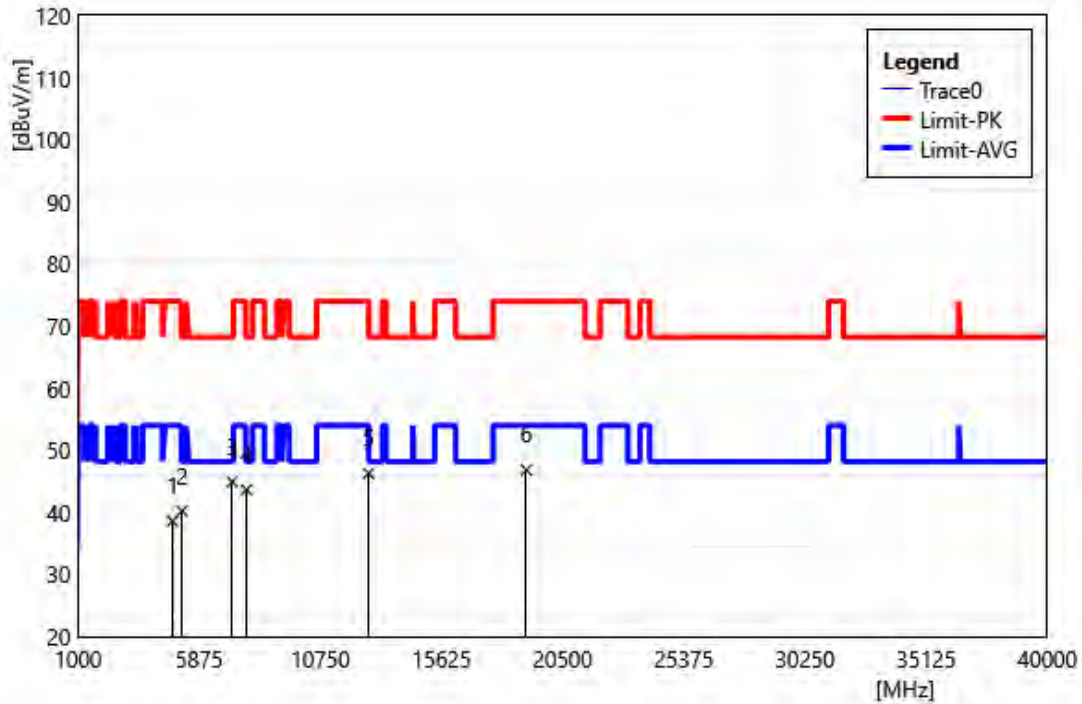

ID	Frequency MHz	Reading dBuV	Correct Factor dB/m	Result dBuV/m	Limit dBuV/m	Margin dB	Remark
1	4804.00	37.30	1.30	38.60	74.00	-35.40	PEAK
2	5186.00	38.64	1.57	40.21	68.20	-27.99	PEAK
3	7206.00	38.66	6.27	44.93	68.20	-23.27	PEAK
4	7779.00	37.39	6.23	43.62	68.20	-24.58	PEAK
5	12690.00	38.37	7.93	46.30	74.00	-27.70	PEAK
6	19035.00	39.37	7.47	46.84	74.00	-27.16	PEAK

--- END---