

Part 2: RF Exposure Evaluation Report for FCC (Test Under Dynamic Transmission Condition)

Applicant Name	: Getac Technology Corporation
Applicant Address	: 5F., Building A, No. 209, Sec. 1, Nangang Rd., Nangang Dist., Taipei City, 115018, Taiwan
Product Name	: 5G/LTE data card
Brand Name	: Telit
Model Number	: FN990A28
FCC ID	: QYLFN990ZX8
Report Number	: USSC23O359001
Compliant Standards	: FCC 47 CFR §2.1093
Sample Received Date	: Oct. 31, 2023
Date of Testing	: Jan. 15, 2024 ~ Jan. 19, 2024
Report Issue Date	: Mar. 01, 2024

The above equipment have been tested by **Eurofins E&E Wireless Taiwan Co., Ltd.**, and found compliance with the requirement of the above standards. The test record, data evaluation & Device Under Test (DUT) configurations represented herein are true and accurate accounts of the measurements of the sample's characteristics under the conditions specified in this report.

Note:

1. The test results are valid only for samples provided by customers and under the test conditions described in this report.
2. This report shall not be reproduced except in full, without the written approval of Eurofins E&E Wireless Taiwan Co., Ltd.
3. The relevant information is provided by customers in this test report. According to the correctness, appropriateness or completeness of the information provided by the customer, if there is any doubt or error in the information which affects the validity of the test results, the laboratory does not take the responsibility.

Approved By :

Roy Wu / SAR Technical Director

Table of Contents

Revision History	3
1. Information of Testing Laboratory	4
2. Device Under Test Information.....	5
3. Time-Averaging Algorithm Validation Strategy	7
4. Validation Test Plan for Sub-6 Transmission.....	9
4.1. Test Sequence Determination for Validation.....	9
4.2. Test Configuration Selection Criteria for Validating Smart Transmit	11
4.2.1. Test Configuration Selection for Time-Varying Tx Power Transmission	11
4.2.2. Test Configuration Selection for Change in Call	12
4.2.3. Test Configuration Selection for Change in Technology / Band.....	12
4.2.4. Test Configuration Selection for Change in Antenna	12
4.2.5. Test Configuration Selection for Change in Device State	13
4.2.6. Test Configuration Selection for Change in Time Window	13
4.2.7. Test Configuration Selection for SAR Exposure Switching.....	13
4.3. Test Procedures for Conducted Power Measurement.....	14
4.3.1. Time-Varying Tx Power Transmission Scenario	14
4.3.2. Change in Call Scenario.....	16
4.3.3. Change in Technology and Band	17
4.3.4. Change in Antenna.....	18
4.3.5. Change in Device State.....	18
4.3.6. Change in Time Window	18
4.3.7. SAR Exposure Switching	20
4.3.8. WWAN Backoff When Wi-Fi/BT is Transmitting	21
4.4. Test Procedure for Time-Varying SAR Measurements	22
4.5. Measurement Setup for Sub-6 Transmission	23
4.5.1. Test Setup for Conducted Power.....	23
4.5.2. SAR Measurement Setup.....	25
5. Test Result for Sub-6 Transmission	26
5.1. Test Configurations for Sub-6 Transmission.....	26
5.2. Test Result for Plimit and Pmax	28
5.3. Test Result for Time-Varying Transmit Power.....	29
5.4. Test Result for Call Drop	33
5.5. Test Result for Change in Technology / Band.....	34
5.6. Test Result for Change in Time-Window Switch.....	35
5.7. Test Result for Switch in SAR Exposure	39
5.8. Test Result for Time-varying SAR	41
6. Conclusions for Time-Averaging Feature Validation	46
7. Equipment List.....	47
Appendix A – Test Setup Photographs	
Appendix B – System Check Plots	
Appendix C – Calibration Certificate for Probe	
Appendix D – Calibration Certificate for Dipole	

1. Information of Testing Laboratory

Test Facilities

Company Name: Eurofins E&E Wireless Taiwan Co., Ltd.
 Address No.: 140-1, Changan Street, Bade District, Taoyuan City 334025, Taiwan
 Website: <https://www.atl.com.tw>
 Telephone: +886-3-271-0188
 Fax: +886-3-271-0190
 E-mail: infoEETW@eurofins.com

Test Site Location

- No. 140-1, Changan Street, Bade District, Taoyuan City 334025, Taiwan
 No. 2, Wuquan 5th Rd. Wugu Dist., New Taipei City, Taiwan

Laboratory Accreditation

Location	TAF	FCC	ISED
No. 140-1, Changan Street, Bade District, Taoyuan City 334025, Taiwan	Accreditation No.: 1330	Designation No.: TW0010	Company No.: 7381A CAB ID: TW1330
No. 2, Wuquan 5th Rd. Wugu Dist., New Taipei City, Taiwan	Accreditation No.: 1330	Designation No.: TW0034	Company No.: 28922 CAB ID: TW1330

2. Device Under Test Information

Product Name	5G/LTE data card	
Brand Name	Telit	
Model Name	FN990A28	
FCC ID	QYLFN990ZX8	
Host Information	Product Name: Tablet Trade Name: Getac Model Name: ZX80, ZX80Y(Y= 10 characters, Y can be 0 to 9, A to Z, a to z, "/", "\", "-", "_ " or blank for marketing purpose) All models are electrically identical, different model names are for marketing purpose.	
Supported Wireless Technologies	Tx Frequency (MHz)	Operating Mode
	WCDMA Band 2 : 1852.4 ~ 1907.6 Band 4 : 1712.4 ~ 1752.6 Band 5 : 826.4 ~ 846.6	UMTS Rel. 99 (Voice / Data) HSDPA (Rel. 5) HSUPA (Rel. 6) HSPA+ (Rel. 7) DC-HSDPA (Rel. 8)
	LTE Band 2 : 1850.7 ~ 1909.3 Band 4 : 1710.7 ~ 1754.3 Band 5 : 824.7 ~ 848.3 Band 7 : 2502.5 ~ 2567.5 Band 12 : 699.7 ~ 715.3 Band 13 : 779.5 ~ 784.5 Band 14 : 790.5 ~ 795.5 Band 17 : 706.5 ~ 713.5 Band 25 : 1850.7 ~ 1914.3 Band 26 : 814.7 ~ 848.3 Band 30 : 2307.5 ~ 2312.5 Band 38 : 2572.5 ~ 2617.5 Band 41 : 2498.5 ~ 2687.5 Band 42 : 3552.5 ~ 3597.5 Band 43 : 3652.5 ~ 3697.5 Band 48 : 3552.5 ~ 3697.5 Band 66 : 1710.7 ~ 1779.3 Band 71 : 665.5 ~ 695.5	QPSK, 16QAM, 64QAM, 256QAM
	5G NR FR1 n2 : 1852.5 ~ 1907.5 n5 : 826.5 ~ 846.5 n7 : 2502.5 ~ 2567.5 n25 : 1852.5 ~ 1912.5 n30 : 2307.5 ~ 2312.5 n38 : 2575 ~ 2615 n41 : 2501.01 ~ 2685, 2506.02 ~ 2679.99 n48 : 3555 ~ 3694.98 n66 : 1712.5 ~ 1777.5 n71 : 665.5 ~ 695.5 n77 : 3455.01 ~ 3645, 3705 ~ 3975 n78 : 3455.01 ~ 3544.98, 3705 ~ 3795	CP-OFDM $\pi/2$ BPSK, QPSK, 16QAM, 64QAM, 256QAM DFT-s-OFDM QPSK, 16QAM, 64QAM, 256QAM
	WLAN 2.4G : 2412 ~ 2462 5G : 5180 ~ 5240, 5260 ~ 5320, 5500 ~ 5700, 5745 ~ 5825 6G : 5935 ~ 6415, 6435 ~ 6515, 6535 ~ 6875, 6895 ~ 7115	2.4G : 802.11b/g/n/ac/ax 5G : 802.11a/n/ac/ax 6G : 802.11a/ax
	Bluetooth 2402 ~ 2480	BR, EDR, LE

Note:

The above DUT information is declared by manufacturer and for more detailed features description please refers to the manufacturer's specifications or User's Manual.

Time-Averaging for SAR

This device is enabled with Qualcomm Smart Transmit algorithm to control and manage transmitting power in real time and to ensure that the time-averaged RF exposure from 3G/LTE/5G NR WWAN is in compliance with FCC requirements. This *Part 0* report shows SAR characterization of WWAN radios for 3G/LTE/5G NR sub-6. The characterization is achieved by determining *Plimit* for 3G/LTE/5G NR sub-6 that corresponds to the exposure design targets after accounting for all device design related uncertainties. The SAR characterization is denoted as SAR Char in this report.

The compliance test under the static transmission scenario and simultaneous transmission analysis are reported in *Part 1* report. The validation of the time-averaging algorithm and compliance under the dynamic (time-varying) transmission scenario for WWAN technologies are reported in *Part 2* report.

DUT contains embedded file system (EFS) version 15 configured for the first generation (GEN1). Additionally, this device supports WLAN and Bluetooth technologies, but the output power of these modems is not controlled by the Smart Transmit algorithm.

Nomenclature for Part 0 Report

Technology	Term	Description
3G/LTE/5G NR	<i>Plimit</i>	Power level that corresponds to the exposure design target (<i>SAR_design_target</i>) after accounting for all device design related uncertainties
	<i>Pmax</i>	Maximum tune up output power
	<i>SAR_design_target</i>	Target SAR level < SAR limit after accounting for all device design related uncertainties
	<i>SAR Char</i>	Table containing <i>Plimit</i> for all technologies and bands

3. Time-Averaging Algorithm Validation Strategy

To validate the time averaging feature and demonstrate the compliance in Tx varying transmission conditions, the following transmission scenarios are covered in the *Part 2* test:

1. **During a time-varying Tx power transmission:** To prove that the Smart Transmit feature accounts for Tx power variations in time accurately.
2. **During a call disconnect and re-establish scenario:** To prove that the Smart Transmit feature accounts for history of past Tx power transmissions accurately.
3. **During a technology / band handover:** To prove that the Smart Transmit feature functions correctly during transitions in technology / band.
4. **During an antenna switch:** To prove that the Smart Transmit feature functions correctly during transitions in antenna (such as AsDiv scenario).
5. **During a DSI (Device State Index) change:** To prove that the Smart Transmit feature functions correctly during transition from one device state (DSI) to another.
6. **During time window switch:** To prove that the Smart Transmit feature correctly handles the transition from one time window to another specified by FCC while maintains the normalized time-averaged RF exposure to be less than normalized FCC limit of 1.0 at all times.
7. **SAR exposure switching between two active radios (radio1 and radio2):** To prove that the Smart Transmit feature functions correctly and ensures total RF exposure compliance when exposure varies among SAR_radio1 only, SAR_radio1 + SAR_radio2, and SAR_radio2 only scenarios.

As described in *Part 0* report, the RF exposure is proportional to the Tx power for a SAR-characterized wireless device. Thus, feature validation in *Part 2* can be effectively performed through conducted (for $f < 6$ GHz) power measurement. Therefore, the compliance demonstration under dynamic transmission conditions and feature validation are done in conducted/radiated power measurement setup for transmission scenario 1 through 7.

To add confidence in the feature validation, the time-averaged SAR measurements are also performed but only performed for transmission scenario 1 to avoid the complexity in SAR measurement (such as, for scenario 3 requiring change in SAR probe calibration file to accommodate different bands and/or tissue simulating liquid).

The strategy for testing in Tx varying transmission condition is outlined as follows:

Conducted Power / Radiated Power Measurement

- Demonstrate the total RF exposure averaged over FCC defined time windows does not exceed FCC's SAR and PD limits, through time-averaged power measurements.
- Measure conducted Tx power (for $f < 6$ GHz) versus time.
- Convert it into RF exposure and divide by respective FCC limits to get normalized exposure versus time.
- Perform running time-averaging over FCC defined time windows.
- Demonstrate that the total normalized time-averaged RF exposure is less than 1 for all transmission scenarios at all times.

Mathematical expression:

➤ For Sub-6 transmission only:

$$1g_or_10gSAR(t) = \frac{conducted_Tx_power(t)}{conducted_Tx_power_Plimit} * 1g_or_10gSAR_Plimit \quad (1)$$

$$\frac{1}{T_{SAR}} \int_{t-T_{SAR}}^t 1g_or_10gSAR(t) dt \leq \frac{FCC\ SAR_{limit}}{FCC\ SAR_{limit}} \leq 1 \quad (2)$$

where, *conducted_Tx_power(t)*, *conducted_Tx_power_Plimit*, and *1g_or_10gSAR_Plimit* correspond to the measured instantaneous conducted Tx power, measured conducted Tx power at *Plimit*, and measured 1gSAR or 10gSAR values at *Plimit* corresponding to sub-6 transmission. The *Plimit* is the parameters pre-defined in *Part 0* and loaded via Embedded File System (EFS) onto the DUT. *TSAR* is the FCC defined time window for sub-6 radio.

RF Exposure Measurement

- Demonstrate the total RF exposure averaged over FCC defined time windows does not exceed FCC’s SAR limits, through time-averaged SAR measurements. Note as mentioned earlier, this measurement is performed for transmission scenario 1 only.
- For Sub-6 transmission only, measure instantaneous SAR versus time; for LTE + Sub-6 NR transmission, request low power (or all-down bits) on LTE so that measured SAR predominantly corresponds to Sub-6 NR.
- Convert it into RF exposure and divide by respective FCC limits to obtain normalized exposure versus time.
- Perform time averaging over FCC defined time window.
- Demonstrate that the total normalized time-averaged RF exposure is less than 1 for transmission scenario 1 at all times.

Mathematical expression:

➤ For sub-6 transmission only:

$$1g_or_10gSAR(t) = \frac{pointSAR(t)}{pointSAR_{Plimit}} * 1g_or_10gSAR_Plimit \quad (6)$$

$$\frac{1}{T_{SAR}} \int_{t-T_{SAR}}^t 1g_or_10gSAR(t) dt \leq \frac{FCC\ SAR_{limit}}{FCC\ SAR_{limit}} \leq 1 \quad (7)$$

where, *pointSAR(t)*, *pointSAR_Plimit*, and *1g_or_10gSAR_Plimit* correspond to the measured instantaneous point SAR, measured point SAR at *Plimit*, and measured 1gSAR or 10gSAR values at *Plimit* corresponding to sub-6 transmission.

Note: SPEAG DASY8 measurement system measures relative E-field, and provides ratio in dB given by

$$10 * \log_{10} \left\{ \frac{[pointE(t)]^2}{([pointE_{input.power.limit}]^2)} \right\} \text{versus time} \quad (11)$$

4. Validation Test Plan for Sub-6 Transmission

This chapter provides the test plan and test procedure for validating Qualcomm Smart Transmit feature for Sub-6 transmission. The 100 seconds time window for operating $f < 3$ GHz is used as an example to detail the test procedures in this chapter. The same test plan and test procedures described in this chapter apply to 60 seconds time window for operating $3 \text{ GHz} \leq f < 6 \text{ GHz}$.

4.1. Test Sequence Determination for Validation

Following the FCC recommendation, two test sequences having time-variation in Tx power are predefined for Sub-6 ($f < 6 \text{ GHz}$) validation:

- Test Sequence 1: Request DUT to transmit at maximum power, measured P_{max} , for 80s, then requesting for half of the maximum power, i.e., measured $P_{max}/2$, for the rest of the time.
- Test Sequence 2: Request DUT to transmit at time-varying Tx power levels. This sequence is generated relative to measured P_{max} , measured P_{limit} and calculated $Preserve$ (= measured P_{limit} - $Reserve_power_margin$) of DUT based on measured P_{limit} .

Note: For test sequence generation, “measured P_{limit} ” and “measured P_{max} ” are used instead of the “ P_{limit} ” specified in EFS entry and “ P_{max} ” specified for the device, because the Smart Transmit feature operates against the actual power level of the “ P_{limit} ” that was calibrated for the DUT. The “measured P_{limit} ” accurately reflects what the feature is referencing to, therefore, it should be used during feature validation testing. The RF tune up and device-to-device variation are already considered in *Part 0: Evaluation Report for SAR Char* prior to determining P_{limit} .

1. Test sequence is generated based on below parameters of the DUT:
 - a. Measured maximum power (P_{max})
 - b. Measured $Tx_power_at_SAR_design_target$ (P_{limit})
 - c. $Reserve_power_margin$ ($Preserve$)
 $Preserve \text{ (dBm)} = \text{measured } P_{limit} \text{ (dBm)} - Reserve_power_margin \text{ (dB)}$
 - d. $FCC \ SAR_time_window$ (100s for $f < 3 \text{ GHz}$, 60s for $3 \text{ GHz} < f \leq 6 \text{ GHz}$, and 30s for $6 \text{ GHz} < f \leq 10 \text{ GHz}$)

2. Test Sequence 1 Waveform:

Based on the parameters above, the test sequence 1 is generated with one transition between high and low Tx powers. Here, high power = P_{max} ; low power = $P_{max}/2$, and the transition occurs after 80 seconds at high power P_{max} . As long as the power enforcement is taking into effective during one 100s/60s time window, the validation test with this defined test sequence 1 is valid, otherwise, select other radio configuration (band / DSI within the same technology group) having lower P_{limit} for this test. The test sequence 1 waveform is shown below:

Figure 4-1: Test Sequence 1 Waveform

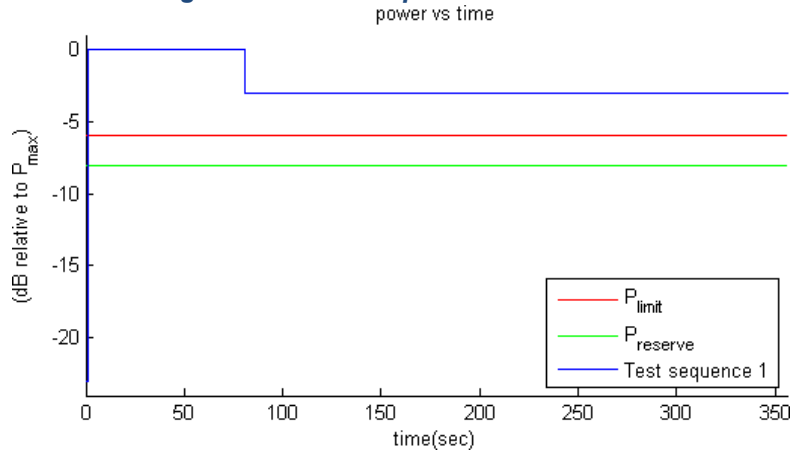

3. Test Sequence 2 Waveform:

Based on the parameters above, the test sequence 2 is generated as described in below Table, which contains two 170 second-long sequences (yellow and green highlighted rows) that are mirrored around the center row of 20s, resulting in a total duration of 360 seconds:

Time Duration (seconds)	dB relative to P _{limit} or P _{reserve}
15	Preserve – 2
20	P _{limit}
20	(P _{limit} + P _{max})/2 averaged in mW and rounded to nearest 0.1 dB step
10	Preserve – 6
20	P _{max}
15	P _{limit}
15	Preserve – 5
20	P _{max}
10	Preserve – 3
15	P _{limit}
10	Preserve – 4
20	(P _{limit} + P _{max})/2 averaged in mW and rounded to nearest 0.1 dB step
10	Preserve – 4
15	P _{limit}
10	Preserve – 3
20	P _{max}
15	Preserve – 5
15	P _{limit}
20	P _{max}
10	Preserve – 6
20	(P _{limit} + P _{max})/2 averaged in mW and rounded to nearest 0.1 dB step
20	P _{limit}
15	Preserve – 2

The test sequence 2 waveform is shown in Figure 4-2.

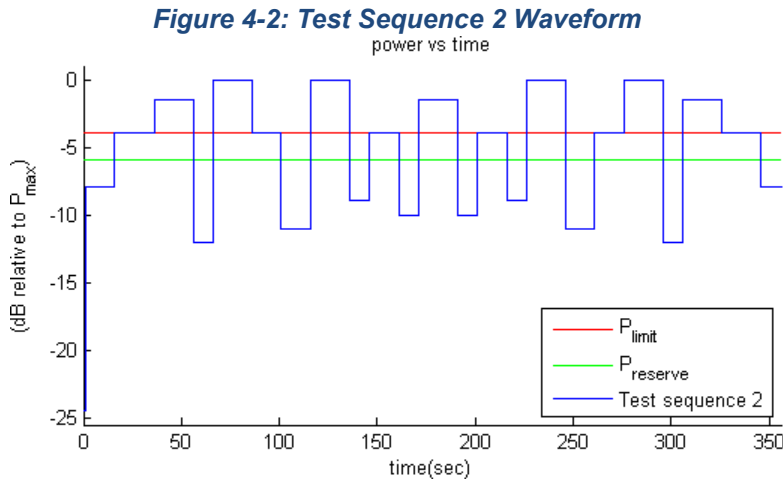

4.2. Test Configuration Selection Criteria for Validating Smart Transmit

For validating the Smart Transmit feature, this section provides the general guidance to select test cases.

4.2.1. Test Configuration Selection for Time-Varying Tx Power Transmission

The Smart Transmit time averaging feature operation is independent of bands, modes, and channels for a given technology. Hence, validation of Smart Transmit in one band / mode / channel per technology is sufficient.

The criteria for the selection are based on the *P_{limit}* values determined in *Part 0* report. Select the band* in each supported technology that correspond to least** or highest*** *P_{limit}* values that are less than *P_{max}* for validating Smart Transmit.

- * If one *P_{limit}* level applies to all the bands within a technology, then only one band needs to be tested. In this case, within the bands having the same *P_{limit}*, the radio configuration (e.g., # of RBs, channel#) and device position that correspond to the highest measured 1gSAR at *P_{limit}* shown in *Part 1* report is selected.
- ** In case of multiple bands having the same least *P_{limit}* within the technology, then select the band having the highest measured 1gSAR at *P_{limit}*.
- *** The band having a higher *P_{limit}* needs to be properly selected so that the power limiting enforced by Smart Transmit can be validated using the pre-defined test sequences. If the highest *P_{limit}* in a technology is too high where the power limiting enforcement is not needed when testing with the pre-defined test sequences, then the next highest level is checked. This process is continued within the technology until the second band for validation testing is determined.

4.2.2. Test Configuration Selection for Change in Call

The criteria to select a test configuration for call-drop measurement is:

- Select technology / band with least *Plimit* among all supported technologies / bands, and select the radio configuration (e.g., # of RBs, channel#) in this technology / band that corresponds to the highest measured 1gSAR at *Plimit* listed in *Part 1* report.
- In case of multiple bands having same least *Plimit*, then select the band having the highest measured 1gSAR at *Plimit* in *Part 1* report.
- Test for change in call is not required if all $Plimit > Pmax$.

This test is performed with the DUT being requested to transmit at maximum power, the above band selection will result in Tx power enforcement (i.e., DUT forced to have Tx power at *Preserve*) for longest duration in one FCC defined time window. The call change (call drop / reestablish) is performed during the Tx power enforcement duration (i.e., during the time when DUT is forced to have Tx power at *Preserve*). One test is sufficient as the feature operation is independent of technology and band.

4.2.3. Test Configuration Selection for Change in Technology / Band

The selection criteria for this measurement is, for a given antenna, to have DUT switch from a technology / band with lowest *Plimit* within the technology group (in case of multiple bands having the same *Plimit*, then select the band with highest measured 1gSAR at *Plimit*) to a technology/band with highest *Plimit* within the technology group, in case of multiple bands having the same *Plimit*, then select the band with lowest measured 1gSAR at *Plimit* in *Part 1* report, or vice versa.

This test is performed with the DUT being requested to transmit at maximum power, the technology / band switch is performed during Tx power enforcement duration (i.e., during the time when DUT is forced to have Tx power at *Preserve*). One test is sufficient as the feature operation is independent of technology and band.

4.2.4. Test Configuration Selection for Change in Antenna

The criteria to select a test configuration for antenna switch measurement is:

- Whenever possible and supported by the DUT, first select antenna switch configuration within the same technology / band (i.e., same technology and band combination).
- Then, select any technology / band that supports multiple Tx antennas, and has the highest difference in *Plimit* among all supported antennas.
- In case of multiple bands having same difference in *Plimit* among supported antennas, then select the band having the highest measured 1gSAR at *Plimit* in *Part 1* report.
- Test for change in antenna is not required if all $Plimit > Pmax$.

This test is performed with the DUT being requested to transmit in selected technology / band at maximum power, and antenna change is conducted during Tx power enforcement duration (i.e., during the time when DUT is forced to have Tx power at *Preserve*). One test is sufficient as the feature operation is independent of technology and band.

4.2.5. Test Configuration Selection for Change in Device State

The criteria to select a test configuration for device state switch measurement is:

- Select a technology / band / antenna having the $P_{limit} < P_{max}$ within any technology and DSI (Device State Index) group, and for the same technology/band/antenna having a different P_{limit} in any other DSI group. Note that the selected DSI transition need to be supported by the device.
- Test for change in device state is not required if all $P_{limit} > P_{max}$.

This test is performed with the DUT being requested to transmit at maximum power in selected technology / band / antenna / DSI, and DSI change is conducted during Tx power enforcement duration (i.e., during the time when DUT is forced to have Tx power at sustainable level). One test is sufficient as the feature operation is independent of technology, band, antenna and DSI.

4.2.6. Test Configuration Selection for Change in Time Window

The FCC specifies different time window for time averaging based on operation frequency. The criteria to select a test configuration for validating Smart Transmit feature and demonstrating the compliance during the change in time window is:

- Select any technology/band that has operation frequency classified in one time window defined by FCC (such as 100 seconds time window), and its corresponding P_{limit} is less than P_{max} if possible.
- Select the 2nd technology/band that has operation frequency classified in a different time window defined by FCC (such as 60 seconds time window), and its corresponding P_{limit} is less than P_{max} if possible.
- It is preferred both P_{limit} values of two selected technology/band are less than corresponding P_{max} , but if not possible or due to limitation of test setup, then at least one of technologies/bands has its P_{limit} less than P_{max} .

This test is performed with the DUT being requested to transmit at maximum power in selected technology / band. Test for one pair of time windows selected is sufficient as the feature operation is the same.

4.2.7. Test Configuration Selection for SAR Exposure Switching

If supported, the test configuration for SAR exposure switching should cover:

1. SAR exposure switch when two active radios are in the same time window.
2. SAR exposure switch when two active radios are in different time windows. One test with two active radios in any two different time windows is sufficient as Smart Transmit operation is the same for RF exposure switch in any combination of two different time windows. For device supporting LTE + mmW NR, this test is covered in SAR vs PD exposure switch validation.

The Smart Transmit time averaging operation is independent of the source of SAR exposure (for example, LTE vs. Sub-6 NR) and ensures total time-averaged RF exposure compliance. Hence, validation of Smart Transmit in any one simultaneous SAR transmission scenario (i.e., one combination for LTE + Sub-6 NR transmission) is sufficient, where the SAR exposure varies among SARradio1 only, SARradio1 + SARradio2, and SARradio2 only scenarios.

The criteria to select a test configuration for validating Smart Transmit feature during SAR exposure switching scenarios is:

- Select any two Sub-6 technologies/bands that the DUT supports simultaneous transmission (for example, LTE + Sub-6 NR).
- Among all supported simultaneous transmission configurations, the selection order is:
 1. Select one configuration where both P_{limit} of radio1 and radio2 is less than their corresponding P_{max} , preferably, with different P_{limit} . If this configuration is not available, then,
 2. Select one configuration that has P_{limit} less than its P_{max} for at least one radio. If this cannot be found, then,
 3. Select one configuration that has P_{limit} of radio1 and radio2 greater than P_{max} but with least delta ($P_{limit} - P_{max}$).

This test for one simultaneous transmission scenario is sufficient as the feature operation is the same.

4.3. Test Procedures for Conducted Power Measurement

This section provides general conducted power measurement procedures to perform compliance test under dynamic transmission scenarios described in Section 3. In practice, an adjustment can be made in these procedures. The justification / clarification may be provided.

4.3.1. Time-Varying Tx Power Transmission Scenario

This test is performed with the two pre-defined test sequences described in Section 4.1 for all the technologies and bands selected in Section 4.2.1. The purpose of the test is to demonstrate the effectiveness of power limiting enforcement and that the time-averaged SAR (corresponding time-averaged Tx power) does not exceed the FCC limit at all times (see Eq. (1) and (2)).

<Test Procedure>

1. Measure P_{max} , P_{limit} and calculate $Reserve$ (measured $P_{limit} - Reserve_power_margin$) and follow Section 4.1 to generate the test sequences for all the technologies and bands selected in Section 4.2.1. Both test sequence 1 and test sequence 2 are created based on measured P_{max} and measured P_{limit} of the DUT. Test condition to measure P_{max} and P_{limit} is:
 - a. Measure P_{max} with Smart Transmit disabled and callbox set to request maximum power.
 - b. Measure P_{limit} with Smart Transmit enabled and $Reserve_power_margin$ set to 0 dB, and callbox set to request maximum power.
2. Set $Reserve_power_margin$ to actual (intended) value (3 dB for this DUT based on Part 1 report) and reset power on DUT to enable Smart Transmit, establish radio link in desired radio configuration, with callbox requesting the DUT to transmit at pre-defined test sequence 1, measure and record Tx power versus time, and then convert the conducted Tx power into 1gSAR or 10gSAR value (see Eq. (1)) using measured P_{limit} from above Step 1. Perform running time average to determine time-averaged power and 1gSAR or 10gSAR versus time as illustrated in Figure 4-3 where using 100 seconds time window as an example.

Figure 4-3: Running Average Illustration

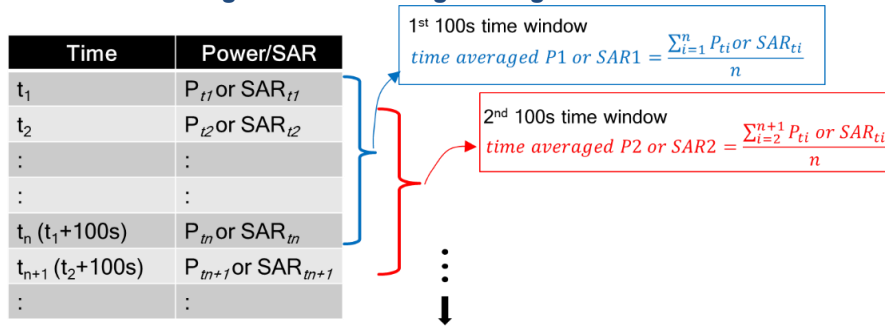

Note: In Eq. (1), instantaneous Tx power is converted into instantaneous 1gSAR or 10gSAR value by applying the measured worst-case 1gSAR or 10gSAR value at *P_{limit}* for the corresponding technology / band / antenna / DSI reported in *Part 1* report.

Note: For an easier computation of the running time average, 0 dBm can be added at the beginning of the test sequences the length of the responding time window, for example, add 0 dBm for 100 seconds so the running time average can be directly performed starting with the first 100 seconds data using excel spreadsheet. This technique applies to all tests performed in this *Part 2* report for easier time-averaged computation using excel spreadsheet.

3. Make one plot containing:
 - a. Instantaneous Tx power versus time measured in Step 2,
 - b. Requested Tx power used in Step 2 (test sequence 1),
 - c. Computed time-averaged power versus time determined in Step 2,
 - d. Time-averaged power limit (corresponding to FCC SAR limit of 1.6 W/kg for 1gSAR or 4.0 W/kg for 10gSAR) given by

$$Time\ averaged\ power\ limit = meas.P_{limit} + 10 * \log \left(\frac{FCC\ SAR\ limit}{meas.SAR_P_{limit}} \right) \tag{12}$$

where *meas.P_{limit}* and *meas.SAR_P_{limit}* correspond to measured power at *P_{limit}* and measured SAR at *P_{limit}*.

4. Make another plot containing:
 - a. Computed time-averaged 1gSAR or 10gSAR versus time determined in Step 2.
 - b. FCC 1gSARlimit of 1.6 W/kg or FCC 10gSARlimit of 4.0 W/kg.
5. Repeat Steps 2 to 4 for pre-defined test sequence 2 and replace the requested Tx power (test sequence 1) in Step 2 with test sequence 2.
6. Repeat Steps 2 to 5 for all the selected technologies and bands.

The validation criteria are, at all times, the time-averaged power versus time shown in Step 3 plot shall not exceed the time-averaged power limit (defined in Eq. (12)), in turn, the time-averaged 1gSAR or 10gSAR versus time shown in Step 4 plot shall not exceed the FCC limit of 1.6 W/kg for 1gSAR or 4.0 W/kg for 10gSAR (i.e., Eq. (2)).

4.3.2. Change in Call Scenario

This test is to demonstrate that Smart Transmit feature accurately accounts for the past Tx powers during time-averaging when a new call is established.

The call disconnection and re-establishment need to be performed during power limit enforcement (i.e., when the DUT's Tx power is at *Preserve* level) to demonstrate the continuity of RF exposure management and limiting in call change scenario. In other words, the RF exposure averaged over any FCC defined time window (including the time windows containing the call change) doesn't exceed the FCC limit of 1.6 W/kg for 1gSAR or 4.0 W/kg for 10gSAR.

<Test Procedure>

1. Measure *P_{limit}* for the technology / band selected in Section 4.2.2. Measure *P_{limit}* with Smart Transmit enabled and *Reserve_power_margin* set to 0 dB, and callbox set to request maximum power.
2. Set *Reserve_power_margin* to actual (intended) value and reset power on DUT to enable Smart Transmit.
3. Establish radio link with callbox in the selected technology/band.
4. Request DUT's Tx power at 0 dBm for at least one time window specified for the selected technology / band, followed by requesting DUT to transmit at maximum Tx power for about ~60 seconds, and then drop the call for ~10 seconds. Afterwards, re-establish another call in the same radio configuration (i.e., same technology / band / channel) and continue callbox requesting DUT to transmit at maximum Tx power for the remaining time of at least another entire duration of the specified time window. Measure and record Tx power versus time.
5. Once the measurement is done, extract instantaneous Tx power versus time, and convert the measured conducted Tx power into 1gSAR or 10gSAR value using Eq. (1), and then perform the running time average to determine time-averaged 1gSAR or 10gSAR versus time.

Note: In Eq. (1), instantaneous Tx power is converted into instantaneous 1gSAR or 10gSAR value by applying the measured worst-case 1gSAR or 10gSAR value at *P_{limit}* for the corresponding technology / band / antenna / DSI reported in *Part 1* report.

6. Make one plot containing: (a) instantaneous Tx power versus time, (b) requested power, (c) computed time-averaged power, (d) time-averaged power limit calculated using Eq. (12).
7. Make another plot containing: (a) computed time-averaged 1gSAR or 10gSAR versus time, and (b) FCC limit of 1.6 W/kg for 1gSAR or 4.0 W/kg for 10gSAR.

The validation criteria are, at all times, the time-averaged power versus time shall not exceed the time-averaged power limit (defined in Eq. (12)), in turn, the time-averaged 1gSAR or 10gSAR versus time shall not exceed the FCC limit of 1.6 W/kg for 1gSAR or 4.0 W/kg for 10gSAR (i.e., Eq. (2)).

4.3.3. Change in Technology and Band

This test is to demonstrate the correct power control by Smart Transmit during technology switches and/or band handovers.

Similar to the change in call test in Section 4.3.2, to validate the continuity of RF exposure limiting during the transition, the technology and band handover needs to be performed when DUT's Tx power is at *Preserve* level (i.e., during Tx power enforcement) to make sure that the DUT's Tx power from previous *Preserve* level to the new *Preserve* level (corresponding to new technology/band). Since the *Plimit* could vary with technology and band, Eq. (1) can be written as follows to convert the instantaneous Tx power in 1gSAR or 10gSAR exposure for the two given radios, respectively:

$$1g_or_10gSAR_1(t) = \frac{conducted_Tx_power_1(t)}{conducted_Tx_power_Plimit_1} * 1g_or_10gSAR_Plimit_1 \quad (13)$$

$$1g_or_10gSAR_2(t) = \frac{conducted_Tx_power_2(t)}{conducted_Tx_power_Plimit_2} * 1g_or_10gSAR_Plimit_2 \quad (14)$$

$$\frac{1}{T_{SAR}} \left[\int_{t-T_{SAR}}^{t_1} 1g_or_10gSAR_1(t) dt + \int_{t-T_{SAR}}^t 1g_or_10gSAR_2(t) dt \right] \leq 1g_or_10gSAR_{limit} \quad (15)$$

where, *conducted_Tx_power_1(t)*, *conducted_Tx_power_Plimit_1*, and *1g_or_10gSAR_Plimit_1* correspond to the measured instantaneous conducted Tx power, measured conducted Tx power at *Plimit*, and measured 1gSAR or 10gSAR value at *Plimit* of technology1 / band1; *conducted_Tx_power_2(t)*, *conducted_Tx_power_Plimit_2*, and *1g_or_10gSAR_Plimit_2* correspond to the measured instantaneous conducted Tx power, measured conducted Tx power at *Plimit*, and measured 1gSAR or 10gSAR value at *Plimit* of technology2 / band2. Transition from technology1 / band1 to the technology2 / band2 happens at time-instant 't1'.

<Test Procedure>

1. Measure *Plimit* for both the technologies and bands selected in Section 4.2.3. Measure *Plimit* with Smart Transmit enabled and *Reserve_power_margin* set to 0 dB, and callbox set to request maximum power.
2. Set *Reserve_power_margin* to actual (intended) value and reset power on DUT to enable Smart Transmit.
3. Establish radio link with callbox in first technology/band selected.
4. Request DUT to transmit at 0 dBm for at least one time window specified for the selected technology / band, followed by requesting DUT to transmit at maximum Tx power for about ~60 seconds, and then switch to second technology / band selected. Continue with callbox requesting DUT to transmit at maximum Tx power for the remaining time of at least another full duration of the specified time window. Measure and record Tx power versus time for the full duration of the test.
5. Once the measurement is done, extract instantaneous Tx power versus time, and convert the conducted Tx power into 1gSAR or 10gSAR value using Eq. (13) and (14) and corresponding measured *Plimit* values from Step 1 of this section. Perform the running time average to determine time-averaged power and 1gSAR or 10gSAR versus time.

Note: In Eq. (13) & (14), instantaneous Tx power is converted into instantaneous 1gSAR or 10gSAR value by applying the measured worst-case 1gSAR or 10gSAR value at *Plimit* for the corresponding technology / band / antenna / DSI reported in *Part 1* report.

6. Make one plot containing: (a) instantaneous Tx power versus time, (b) requested power, (c) computed time-averaged power, (d) time-averaged power limit calculated using Eq. (12).
7. Make another plot containing: (a) computed time-averaged 1gSAR or 10gSAR versus time, and (b) FCC limit of 1.6 W/kg for 1gSAR or 4.0 W/kg for 10gSAR.

The validation criteria are, at all times, the time-averaged 1gSAR or 10gSAR versus time shall not exceed the FCC limit of 1.6 W/kg for 1gSAR or 4.0 W/kg for 10gSAR (i.e., Eq. (15)).

4.3.4. Change in Antenna

This test is to demonstrate the correct power control by Smart Transmit during antenna switches from one antenna to another. The test procedure is identical to Section 4.3.3, by replacing technology / band switch operation with antenna switch. The validation criteria are, at all times, the time-averaged 1gSAR or 10gSAR versus time shall not exceed FCC limit of 1.6 W/kg for 1gSAR or 4.0 W/kg for 10gSAR.

Note: If the DUT does not support antenna switch within the same technology / band, but has multiple antennas to support different frequency bands, then the antenna switch test is included as part of change in technology and band (Section 4.3.3) test.

4.3.5. Change in Device State

This test is to demonstrate the correct power control by Smart Transmit during DSI switches from one DSI to another. The test procedure is identical to Section 4.3.3, by replacing technology / band switch operation with DSI switch. The validation criteria are, at all times, the time-averaged 1gSAR or 10gSAR versus time shall not exceed FCC limit of 1.6 W/kg for 1gSAR or 4.0 W/kg for 10gSAR.

4.3.6. Change in Time Window

This test is to demonstrate the correct power control by Smart Transmit during the change in averaging time window when a specific band handover occurs. The FCC specifies time-averaging windows of 100 seconds for Tx frequency < 3 GHz, and 60 seconds for Tx frequency between 3 GHz and 6 GHz.

To validate the continuity of RF exposure limiting during the transition, the band handover test needs to be performed when DUT handovers from operation band less than 3 GHz to greater than 3 GHz and vice versa. The equations (1) and (2) in Section 3 can be written as follows for transmission scenario having change in time window.

$$1g_or_10gSAR_1(t) = \frac{conducted_Tx_power_1(t)}{conducted_Tx_power_P_{limit_1}} * 1g_or_10gSAR_P_{limit_1} \quad (16)$$

$$1g_or_10gSAR_2(t) = \frac{conducted_Tx_power_2(t)}{conducted_Tx_power_P_{limit_2}} * 1g_or_10gSAR_P_{limit_2} \quad (17)$$

$$\frac{\frac{1}{T_{1SAR}} \left[\int_{t-T_{1SAR}}^{t_1} 1g_or_10gSAR_1(t) dt \right] + \frac{1}{T_{2SAR}} \left[\int_{t-T_{2SAR}}^t 1g_or_10gSAR_2(t) dt \right]}{1g_or_10gSAR_{limit}} \leq 1 \quad (18)$$

where, $conducted_Tx_power_1(t)$, $conducted_Tx_power_Plimit_1$, and $1g_or_10gSAR_Plimit_1$ correspond to the instantaneous Tx power, conducted Tx power at $Plimit$, and compliance $1gSAR$ or $10gSAR$ values at $Plimit_1$ of band1 with time-averaging window 'T1SAR'; $conducted_Tx_power_2(t)$, $conducted_Tx_power_Plimit_2$, and $1g_or_10gSAR_Plimit_2$ correspond to the instantaneous Tx power, conducted Tx power at $Plimit$, and compliance $1gSAR$ or $10gSAR$ values at $Plimit_2$ of band2 with time- averaging window 'T2SAR'. One of the two bands is less than 3 GHz, another is greater than 3 GHz.

Transition from first band with time-averaging window 'T1SAR' to the second band with time-averaging window 'T2SAR' happens at time-instant 't1'.

<Test Procedure>

1. Measure $Plimit$ for both the technologies and bands selected in Section 4.2.6. Measure $Plimit$ with Smart Transmit enabled and $Reserve_power_margin$ set to 0 dB, callbox set to request maximum power.
2. Set $Reserve_power_margin$ to actual (intended) value and enable Smart Transmit.

Transition from 100s time window to 60s time window, and vice versa

3. Establish radio link with callbox in the technology / band having 100s time window selected in Section 4.2.6.
4. Request DUT to transmit at 0 dBm for at least 100 seconds, followed by requesting DUT to transmit at maximum Tx power for about ~140 seconds, and then switch to second technology/band (having 60s time window) selected in Section 4.2.6. Continue with callbox requesting DUT to transmit at maximum Tx power for about ~60s in this second technology/band, and then switch back to the first technology / band. Continue with callbox requesting DUT to transmit at maximum Tx power for at least another 100 seconds. Measure and record Tx power versus time for the entire duration of the test.
5. Once the measurement is done, extract instantaneous Tx power versus time, and convert the conducted Tx power into $1gSAR$ or $10gSAR$ value (see Eq. (16) and (17)) using corresponding technology / band Step 1 result, and then perform 100 seconds running average to determine time-averaged $1gSAR$ or $10gSAR$ versus time. Note that in Eq. (16) & (17), instantaneous Tx power is converted into instantaneous $1gSAR$ or $10gSAR$ value by applying the worst-case $1gSAR$ or $10gSAR$ value tested in Part 1 for the selected technologies / bands at $Plimit$.
6. Make one plot containing: (a) instantaneous Tx power versus time measured in Step 4.
7. Make another plot containing: (a) instantaneous $1gSAR$ versus time determined in Step 5, (b) computed time-averaged $1gSAR$ versus time determined in Step 5, and (c) corresponding the FCC limit of 1.6 W/kg for $1gSAR$ or 4.0 W/kg for $10gSAR$.

Transition from 60s time window to 100s time window, and vice versa

8. Establish radio link with callbox in the technology/band having 60 seconds time window selected in Section 4.2.6.
9. Request DUT to transmit at 0 dBm for at least 60 seconds, followed by requesting DUT to transmit at maximum Tx power for about ~80 seconds, and then switch to second technology / band (having 100 seconds time window) selected in Section 4.2.6. Continue with callbox requesting DUT to transmit at maximum Tx power for about ~100 seconds in this second technology/band, and then switch back to the first technology / band. Continue with callbox requesting DUT to transmit at maximum Tx power for the remaining time for a total test time of 500 seconds. Measure and record Tx power versus time for the entire duration of the test.
10. Repeat above Step 5~7 to generate the plots.

The validation criteria are, at all times, the time-averaged $1gSAR$ or $10gSAR$ versus time shall not exceed the FCC limit of 1.6 W/kg for $1gSAR$ or 4.0 W/kg for $10gSAR$.

4.3.7. SAR Exposure Switching

This test is to demonstrate that Smart Transmit feature is accurately accounts for switching in exposures among SAR from radio1 only, SAR from both radio1 and radio2, and SAR from radio2 only scenarios, and ensures total time-averaged RF exposure complies with the FCC limit. Here, radio1 represents primary radio (for example, LTE anchor in a NR non-standalone mode call) and radio2 represents secondary radio (for example, Sub-6 NR or mmW NR).

<Test Procedure>

1. Measure conducted Tx power corresponding to P_{limit} for radio1 and radio2 in selected band. Test condition to measure conducted P_{limit} is:
 - Establish device in call with the callbox for radio1 technology / band. Measure conducted Tx power corresponding to radio1 P_{limit} with Smart Transmit enabled and $Reserve_power_margin$ set to 0 dB, callbox set to request maximum power.
 - Repeat above step to measure conducted Tx power corresponding to radio2 P_{limit} . If radio2 is dependent on radio1 (for example, non-standalone mode of Sub-6 NR requiring radio1 LTE as anchor), then establish radio1 + radio2 call with callbox, and request all down bits for radio1 LTE. In this scenario, with callbox requesting maximum power from radio2 Sub-6 NR, measured conducted Tx power corresponds to radio2 P_{limit} (as radio1 LTE is at all-down bits).
2. Set $Reserve_power_margin$ to actual (intended) value, with DUT setup for radio1 + radio2 call. In this description, it is assumed that radio2 has lower priority than radio1. Establish device in radio1+radio2 call, and request all-down bits or low power on radio1, with callbox requesting DUT to transmit at maximum Tx power in radio2 for at least one time window. After one time window, set callbox to request DUT to transmit at maximum Tx power on radio1 (i.e., all-up bits). Continue radio1 + radio2 call with both radios at maximum power for at least one time window, and drop (or request all-down bits on) radio2. Continue radio1 at maximum power for at least one time window. Record the conducted Tx power for both radio1 and radio2 for the entire duration of this test.
3. Once the measurement is done, extract instantaneous Tx power versus time for both radio1 and radio2 links. Convert the conducted Tx power for both these radios into 1gSAR or 10gSAR value (see Eq. (13) and (14)) using corresponding technology / band P_{limit} measured in Step 1, and then perform the running time average to determine time-averaged 1gSAR or 10gSAR versus time.
4. Make one plot containing: (a) instantaneous Tx power versus time measured in Step 2.
5. Make another plot containing: (a) instantaneous 1gSAR versus time determined in Step 3, (b) computed time-averaged 1gSAR versus time determined in Step 3, and (c) corresponding the FCC limit of 1.6 W/kg for 1gSAR or 4.0 W/kg for 10gSAR.

The validation criteria are, at all times, the time-averaged 1gSAR or 10gSAR versus time shall not exceed the FCC limit of 1.6 W/kg for 1gSAR or 4.0 W/kg for 10gSAR.

4.3.8. WWAN Backoff When Wi-Fi/BT is Transmitting

In the case of devices with Smart Transmit EFS version 16 (or higher), the Backoff (dB) entries per WWAN tech / band / DSI / antenna (Sub-6 antenna and mmW module) presented in the EFS are applied by Smart Transmit when Wi-Fi/BT is transmitting.

Smart Transmit operation is independent of tech / band / DSI / antenna, therefore, only two test cases are needed to verify that the WWAN backoff is enforced on WWAN technologies by Smart Transmit for GEN1 or GEN2_MMW configurations when Wi-Fi/BT is transmitting:

1. Sub-6 radio maximum power test for one of the Sub-6 bands that have backoffs configured for when Wi-Fi is transmitting. If backoffs are not configured for all Sub-6 WWAN radios, then this test is not required.
2. mmW NR radio maximum power test with one of the mmW NR bands that have backoffs configured for when Wi-Fi is transmitting. If backoffs are not configured for all mmW NR bands, then this test is not required.

<Test Procedure for Sub-6 WWAN Radio + Active Wi-Fi>

The purpose of the test is to demonstrate that Smart Transmit applies backoff for the selected Sub-6 band when Wi-Fi is transmitting. This test procedure is very similar to the transition tests described in Section 3.3 with the callbox requesting DUT to transmit at maximum power all the time.

1. Select any Sub-6 WWAN band that has backoff configured in the EFS. Measure conducted Tx power corresponding to P_{limit} for Sub-6 WWAN in selected band with Smart Transmit Peak enabled, callbox set to request maximum power and with Wi-Fi turned OFF.

Note: If any of the Sub-6 WWAN bands tested in Section 4.3 has backoff configured, then Step1 here can be avoided if this test is performed after that Section 4.3 test without disturbing the test setup.

2. Set *Reserve_power_margin* to actual (intended) value and reset power on DUT to enable Smart Transmit.
3. Enable Wi-Fi to transmit.
4. Establish Sub-6 WWAN radio link with callbox in selected Sub-6 WWAN band.
5. Request DUT to transmit at 0 dBm for at least 100 seconds, followed by requesting DUT to transmit at maximum Tx power for the remaining time for a total test time of 400 seconds. Measure and record Tx power versus time.
6. Once the measurement is done, extract instantaneous Tx power versus time, and convert the conducted Tx power into 1gSAR or 10gSAR value (see Eq. (1)) using Step 1 result, and then perform 100 seconds running average to determine time-averaged 1gSAR or 10gSAR versus time.

Note: In Eq. (1), instantaneous Tx power is converted into instantaneous 1gSAR or 10gSAR value by applying the worst-case 1gSAR or 10gSAR value of the technology / band at P_{limit} as reported in *Part 1* report.

7. Make plot containing: (a) computed time-averaged 1gSAR or 10gSAR versus time determined in Step 6, and (b) corresponding the FCC limit of 1.6 W/kg for 1gSAR or 4.0 W/kg for 10gSAR.

The validation criteria are, at all times, the time-averaged 1gSAR or 10gSAR versus time plotted in Step 7 shall not exceed $SAR_{design_target} \times 10^{(-Backoff\ (dB)/10)}$ within Sub-6 device uncertainty, where Backoff corresponds to the backoff in dB entered in v16 (or higher) EFS for the tested Sub-6 WWAN band.

4.4. Test Procedure for Time-Varying SAR Measurements

This section provides general time-varying SAR measurement procedures to perform compliance test under dynamic transmission scenarios described in Section 3. In practice, an adjustment can be made in these procedures. The justification / clarification may be provided.

To validate time averaging algorithm through SAR measurement for transmission scenario 1 described in Section 3, the “path loss” between callbox antenna and DUT needs to be calibrated to ensure that the DUT Tx power reacts to the requested power from callbox in a radiated call. It should be noted that when signaling in closed loop mode, protocol-level power control is in play, resulting in DUT not solely following callbox TPC (transmit power control) commands. In other words, DUT response has many dependencies (RSSI, quality of signal, path loss variation, fading, etc.) other than just TPC commands. These dependencies have less impact in conducted setup (as it is a controlled environment and the path loss can be very well calibrated) but have significant impact on radiated testing in an uncontrolled environment, such as SAR test setup. Therefore, the deviation in DUT Tx power from callbox requested power is expected.

The following steps are for time averaging algorithm validation through SAR measurement:

1. “Path Loss” calibration: Place the DUT against the flat section of the SAM Twin phantom in the worst-case position determined based on Section 4.2.1. For each band selected, prior to SAR measurement, perform “path loss” calibration between callbox antenna and DUT. Since the SAR test environment is not controlled and well calibrated for OTA (Over the Air) test, extreme care needs to be taken to avoid the influence from reflections.
2. Time averaging algorithm validation:
 - a. For a given radio configuration (technology / band) selected in Section 4.2.1, enable Smart Transmit and *Reserve_power_margin* set to 0 dB, with callbox to request maximum power, perform area scan, and conduct pointSAR measurement at peak location of the area scan. This pointSAR value, *pointSAR_Plimit* corresponds to pointSAR at the measured *Plimit* obtained in Step 1 of Section 4.3.1.
 - b. Set *Reserve_power_margin* to actual (intended) value and reset power on DUT to enable Smart Transmit, with callbox requesting the DUT to transmit at power levels described by test sequence 1 in Step 1 of Section 4.3.1, conduct pointSAR measurement versus time at peak location of the area scan determined in this section Step 2.a. Once the measurement is done, extract instantaneous pointSAR vs time data, *pointSAR(t)*, and convert it into instantaneous 1gSAR or 10gSAR vs. time by using equation (6) where, *pointSAR_Plimit* corresponds to the value determined in Step 2.a, and *pointSAR(t)* corresponds to instantaneous pointSAR determined in Step 2.a.
 - c. Perform 100 seconds running average to determine time-averaged 1gSAR or 10gSAR versus time.
 - d. Make one plot containing (a) computed time-averaged 1gSAR or 10gSAR versus time determined in Step 2.c, and (b) corresponding the FCC limit of 1.6 W/kg for 1gSAR or 4.0 W/kg for 10gSAR.
 - e. Repeat 2.b ~ 2.d for test sequence 2 generated in Step 1 of Section 4.3.1.
 - f. Repeat 2.a ~ 2.e for all the technologies and bands selected in Section 4.2.1.

The time-averaging validation criteria for SAR measurement are, at all times, the time-averaged 1gSAR or 10gSAR versus time shall not exceed the FCC limit of 1.6 W/kg for 1gSAR or 4.0 W/kg for 10gSAR.

4.5. Measurement Setup for Sub-6 Transmission

4.5.1. Test Setup for Conducted Power

<Legacy Test Setup>

The Rohde & Schwarz CMW500 callbox was used in this test. The test setup schematic is shown in Figure 4-4 for measurements with a single antenna of DUT, and in Figure 4-5 for measurements involving antenna switch. For single antenna measurement, one port (RF1 COM) of the callbox is connected to the RF port of the DUT using a directional coupler. For technology / band switch measurement, one port (RF1 COM) of the callbox used for signaling two different technologies is connected to a combiner, which is in turn connected to a directional coupler. The other end of the directional coupler is connected to a splitter to connect to two RF ports of the DUT corresponding to the two antennas of interest. In the setups, power meter is used to tap the directional coupler for measuring the conducted output power of the DUT. For all legacy conducted tests, only RF1 COM port of the callbox is used to communicate with the DUT.

Note: For this DUT, antenna switch test is included within time-window switch test as the selected technology / band combinations for the time-window switch test are on two different antennas.

All the path losses from RF port of DUT to the callbox RF COM port and to the power meter are calibrated and automatically entered as offsets in the callbox and the power meter via test scripts on the PC used to control callbox and power meter.

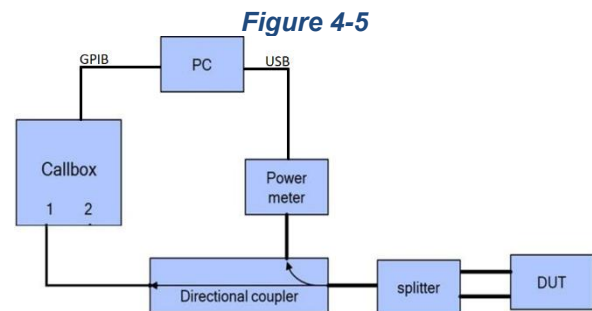
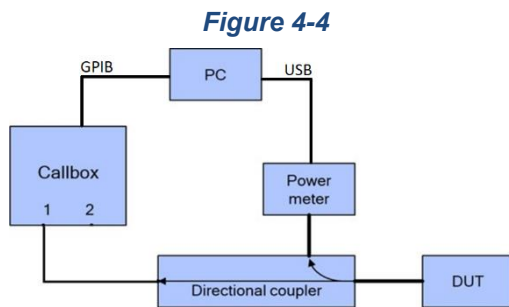

<Sub-6 NR Test Setup>

The MT8000A callbox was used in this test. The test setup schematic is the same as the Legacy Test Setup shown in Figure 4-4. One port of the callbox is connected to the RF port of the DUT using a directional coupler. In the setup, the power meter is used to tap the directional coupler for measuring the conducted output power of the DUT.

All the path losses from RF port of DUT to the callbox RF COM port and to the power meter are calibrated and automatically entered as offsets in the callbox and the power meter via test scripts on the PC used to control callbox and power meter.

<LTE + Sub-6 NR Test Setup>

LTE conducted port and Sub-6 NR conducted port are the same on this DUT, therefore, the LTE and Sub-6 NR signals for power meter measurement are performed on separate paths as shown in Figure 4-6.

All the path losses from RF port of DUT to the callbox RF COM port and to the power meter are calibrated and automatically entered as offsets in the callbox and the power meter via test scripts on the test PC used to control callbox and power meter.

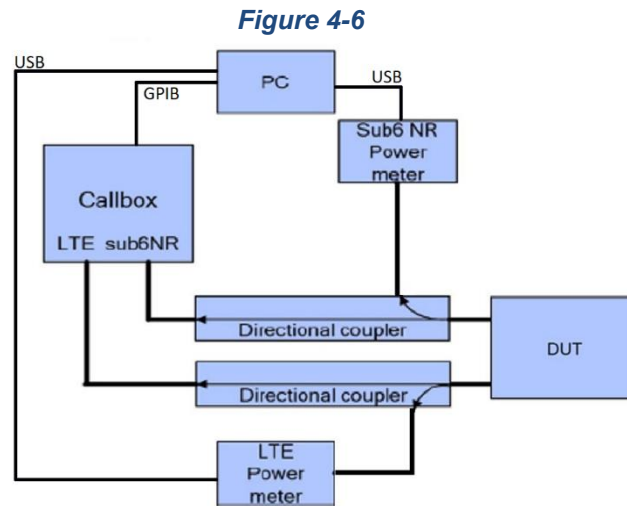

Both the callbox and power meter are connected to the test PC using GPIB and USB cables. Two test scripts are custom made for automation, and the test duration set in the test scripts is 500 seconds.

For time-varying Tx power measurement, the test PC runs the 1st test script to send GPIB commands to control the callbox's requested power versus time, while at the same time to record the conducted power measured at DUT RF port using the power meter. The commands sent to the callbox to request power are:

- 0 dBm for 100 seconds.
- Test sequence 1 or test sequence 2 (defined in Section 4.1 and generated in Section 4.2.1), for 360 seconds.
- Stay at the last power level of test sequence 1 or test sequence 2 for the remaining time.

Power meter readings are periodically recorded every 100 ms. A running average of this measured Tx power over 100 seconds is performed in the post-data processing to determine the 100s-time averaged power.

For call drop, technology / band / antenna switch, and DSI switch tests, after the call is established, the callbox is set to request the DUT to transmit at 0 dBm for 100 seconds while simultaneously starting the 2nd test script runs at the same time to start recording the Tx power measured at DUT RF port using the power meter. After the initial 100 seconds since starting the Tx power recording, the callbox is set to request maximum power from the DUT for the rest of the test. Note that the call drop / re-establish, or technology / band / antenna switch or DSI switch is manually performed when the Tx power of DUT is at *Preserve* level. See Section 4.3 for detailed test procedure of call drop test, technology / band / antenna switch test and DSI switch test.

4.5.2. SAR Measurement Setup

The measurement setup is similar to normal SAR measurement as described in *Part 1* test report. The difference in SAR measurement setup for time-averaging feature validation is that the callbox is signaling in close loop power control mode (instead of requesting maximum power in open loop control mode) and callbox is connected to the test PC using GPIB so that the test script executed on test PC can send GPIB commands to control the callbox's requested power over time (test sequence). The same test script used in conducted setup for time-varying Tx power measurement is also used in this section for running the test sequences during SAR measurements, and the recorded values from the disconnected power meter by the test script were discarded.

As mentioned in Section 4.4, for DUT to follow TPC command sent from the callbox wirelessly, the "path loss" between callbox antenna and the DUT needs to be very well calibrated. Since the SAR chamber is in uncontrolled environment, precautions must be taken to minimize the environmental influences on "path loss". Similarly, in the case of time-varying SAR measurements in Sub-6 NR (with LTE as anchor), "path loss" between callbox antenna and the DUT needs to be carefully calibrated for both LTE link as well as for Sub-6 NR link.

5. Test Result for Sub-6 Transmission

5.1. Test Configurations for Sub-6 Transmission

The *Plimit* values, corresponding to 0.95 W/kg (1gSAR) of *SAR_design_target*, for technologies and bands supported by DUT are derived in *Part 0* report and summarized in Table 5-1.

Table 5-1: Plimit for Supported Technologies and Bands (Plimit in EFS file)

DSI		0	Pmax (Maximum Tune-up Power, dBm)
Averaging Volume		1g	
Test Distance (mm)		0	
WWAN Bands	Tx Antenna	Plimit (dBm)	
WCDMA Band 2	Main	15.0	23.5
WCDMA Band 4	Main	15.4	23.5
WCDMA Band 5	Main	21.1	23.5
LTE B2	Main	14.9	23.0
LTE B4	Main	15.4	23.0
LTE B5	Main	20.3	23.0
LTE B7	Main	13.7	23.0
LTE B12	Main	19.9	23.0
LTE B13	Main	18.8	23.0
LTE B14	Main	19.8	23.0
LTE B17	Main	20.2	23.0
LTE B25	Main	14.8	23.0
LTE B26	Main	20.2	23.0
LTE B38	Main	15.0	23.0
LTE B41 (PC3)	Main	12.5	23.0
LTE B41 (PC2)	Main	12.7	25.5
LTE B42	MIMO 1	12.7	21.5
LTE B43	MIMO 1	14.4	21.5
LTE B48	MIMO 1	12.6	21.5
LTE B66	Main	14.9	23.0
LTE B71	Main	21.2	23.0
5G NR n2	Main	15.2	23.5
5G NR n5	Main	20.4	23.5
5G NR n7	Main	15.9	23.5
5G NR n25	Main	15.7	23.5
5G NR n30	Main	15.1	22.0
5G NR n38	Aux	27.9	24.0
5G NR n41 (PC2)	Aux	26.8	26.5
5G NR n48	MIMO 1	21.4	21.5
5G NR n66	Main	15.1	23.5
5G NR n71	Main	21.3	23.5
5G NR n77 / n78 (PC2)	MIMO 1	20.9	26.5

Note:

1. When $P_{max} < P_{limit}$, the DUT will operate at a power level up to P_{max} .
2. All P_{limit} power levels entered in Table 5-1 correspond to average power levels after accounting for duty cycle in the case of TDD modulation schemes (e.g., LTE-TDD, and Sub-6 NR TDD).
3. Maximum tune up target power, P_{max} , is configured in NV settings in DUT to limit maximum transmitting power. This power is converted into peak power in NV settings for TDD schemes. The DUT maximum allowed output power is equal to $P_{max} + 1.0$ dB device uncertainty.

Based on selection criteria described in Section 4.2.1, the selected technologies / bands for testing time-varying test sequences are highlighted in Table 5-1. Per the manufacturer, the *Reserve_power_margin* (dB) is set to 3 dB in EFS and is used in *Part 2* test.

The radio configurations used in *Part 2* test for selected technologies, bands, DSIs and antennas are listed in Table 5-2. The corresponding worst-case radio configuration 1gSAR values for selected technology / band / DSI are extracted from *Part 1* report and are listed in the last column of Table 5-2.

Based on equations (1) and (6), it is clear that *Part 2* testing outcome is normalized quantity, which implies that it can be applied to any radio configuration within a selected technology / band / DSI. Thus, as long as applying the worst-case SAR obtained from the worst radio configuration in *Part 1* testing to calculate time-varying SAR exposure in equations (1) and (6), the accuracy in compliance demonstration remains the same. Therefore, there may be some differences between the radio configuration selected for *Part 2* testing and the radio configuration associated with worst-case SAR obtained in the *Part 1* evaluation.

Table 5-2: Radio Configurations Selected for Part 2 Test

Test Case #	Test Scenario	Tech	Band	Antenna	DSI	Channel	Frequency (MHz)	Mode	SAR Exposure Scenario	Part 1 Worst Case Measured SAR at Plimit (W/kg)
1	Time-Varying Tx Power (Seq 1 & Seq 2)	WCDMA	4	Main	0	1312	1712.4	RMC12.2K	Tablet, Rear Face, 0 mm	0.949
2		LTE	4	Main	0	20300	1732.5	QPSK, 20M, 1RB, OS0	Tablet, Rear Face, 0 mm	0.95
3		NR	n25 / SA	Main	0	376500	1882.5	DFT-S-OFDM, QPSK 20M, 1RB, OS1	Tablet, Rear Face, 0 mm	0.941
4	Change in Call	LTE	38	Main	0	37850	2595	QPSK, 20M, 1RB, OS0	Tablet, Rear Face, 0 mm	0.936
5	Change in Technology / Band	LTE	43	MIMO 1	0	44340	3675	QPSK, 20M, 1RB, OS0	Tablet, Rear Face, 0 mm	0.805
		WCDMA	4	Main	0	1312	1712.4	RMC12.2K	Tablet, Rear Face, 0 mm	0.949
6	Change in Time Window	LTE	4	Main	0	20300	1732.5	QPSK, 20M, 1RB, OS0	Tablet, Rear Face, 0 mm	0.95
		LTE	43	MIMO 1	0	44340	3675	QPSK, 20M, 1RB, OS0	Tablet, Rear Face, 0 mm	0.805
7	SAR Exposure Switching (EN- DC, same time window)	LTE	2	Main	0	18900	1880	QPSK, 20M, 1RB, OS0	Tablet, Rear Face, 0 mm	0.949
		NR	n71 / NSA	Main	0	133322	666.61	DFT-S-OFDM, QPSK 20M, 1RB, OS1	Tablet, Rear Face, 0 mm	0.826

Based on the selection criteria described in Section 4.2, the radio configurations for the Tx varying transmission test cases listed in Section 3 are:

- 1. Technologies and Bands for Time-Varying Tx Power Transmission:** The test case 1~3 listed in Table 5-2 are selected to test with the test sequences defined in Section 4.1 in both time-varying conducted power measurement and time-varying SAR measurement.
- 2. Technology and Band for Change in Call Test:** LTE Band 38, having the lowest *Plimit* among all technologies and bands (test case 4 in Table 5-2), is selected for performing the call drop test in conducted power setup.
- 3. Technologies and Bands for Change in Technology / Band Test:** Following the guidelines in Section 4.2.3, test case 5 in Table 5-2 is selected for handover test from a technology / band within one technology group (LTE Band 43, Antenna MIMO 1), to a technology / band in the same DSI within another technology group (WCDMA Band 4, Antenna Main) in conducted power setup.
- 4. Technologies and Bands for Change in Time-Window:** Based on selection criteria in Section 4.2.6, for a given test case 6 in Table 5-2 is selected for time window switch between 60s window (LTE B43, Antenna MIMO 1) and 100s window (LTE B4, Antenna Main) in conducted power setup.
- 5. Technologies and Bands for Switch in SAR Exposure:** Based on selection criteria in Section 4.2.7 Scenario 1, test case 7 in Table 5-2 is selected for SAR exposure switching test in one of the supported simultaneous WWAN transmission scenario (i.e., LTE + Sub-6 NR active in the same 100s time window) in conducted power setup.

5.2. Test Result for Plimit and Pmax

The measured *Plimit* for all the selected radio configurations given in Table 5-2 are listed in Table 5-3. The *Pmax* was also measured for radio configurations selected for testing time-varying Tx power transmission scenarios in order to generate test sequences following the test procedures in Section 4.1.

Table 5-3: Measured Plimit and Pmax of Selected Radio Configurations

Test Case #	Test Scenario	Tech	Band	Antenna	DSI	Channel	Frequency (MHz)	Mode	SAR Exposure Scenario	EFS Plimit (dBm)	Tune-up Pmax (dBm)	Measured Plimit (dBm)	Measured Pmax (dBm)
1	Time-Varying Tx Power (Seq 1 & Seq 2)	WCDMA	4	Main	0	1312	1712.4	RMC12.2K	Body	15.4	23.5	15.38	23.53
2		LTE	4	Main	0	20300	1732.5	QPSK, 20M, 1RB, OS0	Body	15.4	23.0	15.10	22.50
3		NR	n25 / SA	Main	0	376500	1882.5	DFT-S-OFDM, QPSK 20M, 1RB, OS1	Body	15.7	23.5	14.81	22.88
4	Change in Call	LTE	38	Main	0	37850	2595	QPSK, 20M, 1RB, OS0	Body	15.0	23.0	14.74	23.26
5	Change in Technology/Band	LTE	43	MIMO 1	0	44340	3675	QPSK, 20M, 1RB, OS0	Body	14.4	21.5	13.53	21.73
		WCDMA	4	Main	0	1312	1712.4	RMC12.2K	Body	15.4	23.5	15.38	23.53
6	Change in Time Window	LTE	4	Main	0	20300	1732.5	QPSK, 20M, 1RB, OS0	Body	15.4	23.0	15.10	22.50
		LTE	43	MIMO 1	0	44340	3675	QPSK, 20M, 1RB, OS0	Body	14.4	21.5	13.53	21.75
7	SAR Exposure Switching (EN-DC, same time window)	LTE	2	Main	0	18900	1880	QPSK, 20M, 1RB, OS0	Body	14.9	23.0	15.02	22.86
		NR	n71 / NSA	Main	0	133322	666.61	DFT-S-OFDM, QPSK 20M, 1RB, OS1	Body	21.3	23.5	21.41	22.84

Note: The device uncertainty of *Pmax* is +/- 1 dB as provided by manufacturer.

5.3. Test Result for Time-Varying Transmit Power

The measurement setup is shown in section 4.5.1. The purpose of the time-varying Tx power measurement is to demonstrate the effectiveness of power limiting enforcement and that the time-averaged Tx power when represented in time-averaged 1gSAR or 10gSAR values does not exceed the FCC limit as shown in Eq. (1) and (2), rewritten below:

$$1g_or_10gSAR(t) = \frac{conducted_Tx_power(t)}{conducted_Tx_power_P_{limit}} * 1g_or_10gSAR_P_{limit} \quad (1)$$

$$\frac{1}{T_{SAR}} \int_{t-T_{SAR}}^t 1g_or_10gSAR(t) dt \leq \frac{FCC\ SAR_{limit}}{FCC\ SAR_{limit}} \leq 1 \quad (2)$$

where, *conducted_Tx_power(t)*, *conducted_Tx_power_Plimit*, and *1g_or_10gSAR_Plimit* correspond to the measured instantaneous conducted Tx power, measured conducted Tx power at *Plimit*, and measured 1gSAR or 10gSAR values at *Plimit* reported in *Part 1* test (listed in Table 5-2 of this report as well).

Following the test procedure in Section 4.3, the conducted Tx power measurement for all selected configurations is reported in this section. In all the conducted Tx power plots, the green curve represents time-averaged power and red line represents the conducted power limit that corresponds to the FCC limit of 1.6 W/kg for 1gSAR or 4.0 W/kg for 10gSAR.

Similarly, in all the 1g or 10gSAR plots (when converted using Eq. (1)), the green curve represents the 100s/60s-time averaged 1gSAR or 10gSAR value calculated based on instantaneous 1gSAR or 10gSAR; and the red line limit represents the FCC limit of 1.6 W/kg for 1gSAR or 4.0 W/kg for 10gSAR.

Time-varying Tx power measurements were conducted on test cases #1 ~ #3 in Table 5-2, by generating test sequence 1 and test sequence 2: using measured *Plimit* and measured *Pmax* (last two columns of Table 5-3) for each of these test cases. Measurement results for test cases #1 ~ #3 are given in following.

WCDMA Band 4:

<Test Result for Test Sequence 1>

Time-averaged conducted Tx power is converted / calculated into time-averaged 1gSAR using Equation (1) and plotted below to demonstrate that the time-averaged 1gSAR versus time does not exceed the FCC limit of 1.6 W/kg for 1gSAR:

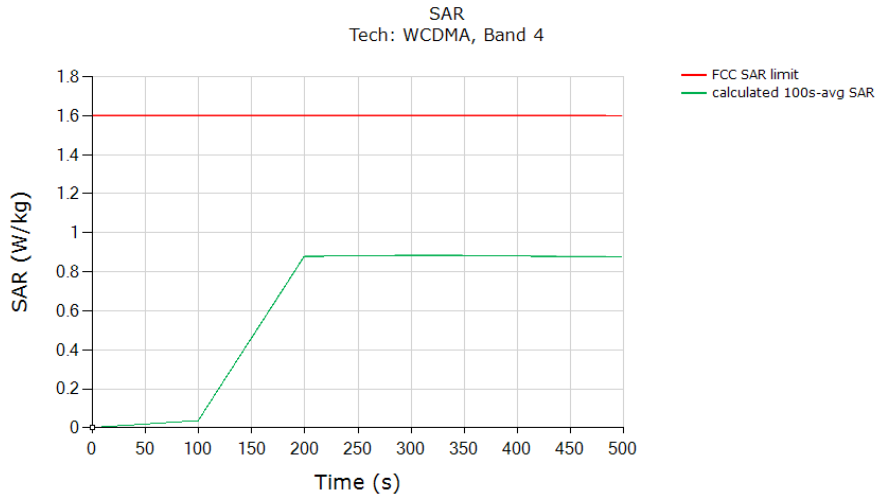

FCC Limit for 1gSAR (W/kg)	1.6
Max. Time-Averaged 1gSAR in Green Curve (W/kg)	0.882
Validated: Max time-averaged SAR in green curve is within 1 dB device uncertainty of measured SAR at <i>Plimit</i> (last column in Table 5-2).	

<Test Result for Test Sequence 2>

Time-averaged conducted Tx power is converted / calculated into time-averaged 1gSAR using Equation (1) and plotted below to demonstrate that the time-averaged 1gSAR versus time does not exceed the FCC limit of 1.6 W/kg for 1gSAR:

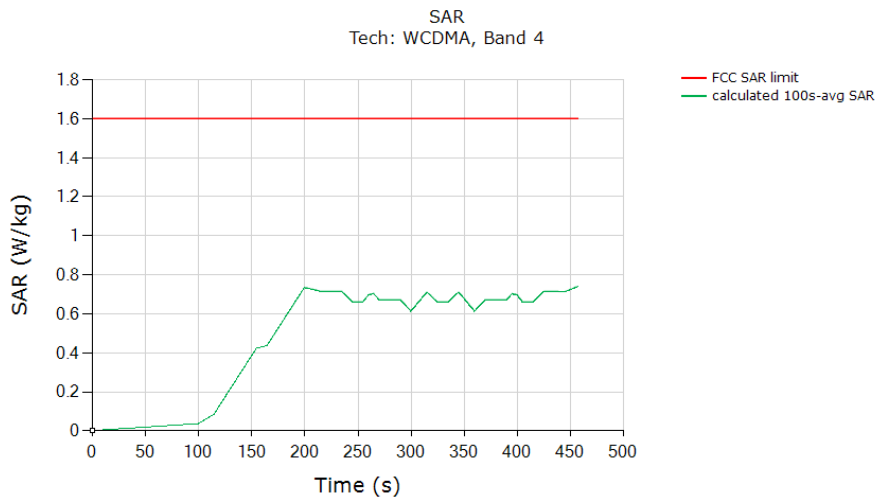

FCC Limit for 1gSAR (W/kg)	1.6
Max. Time-Averaged 1gSAR in Green Curve (W/kg)	0.74
Validated: Max time-averaged SAR in green curve is within 1 dB device uncertainty of measured SAR at <i>Plimit</i> (last column in Table 5-2).	

LTE Band 4:

<Test Result for Test Sequence 1>

Time-averaged conducted Tx power is converted / calculated into time-averaged 1gSAR using Equation (1) and plotted below to demonstrate that the time-averaged 1gSAR versus time does not exceed the FCC limit of 1.6 W/kg for 1gSAR:

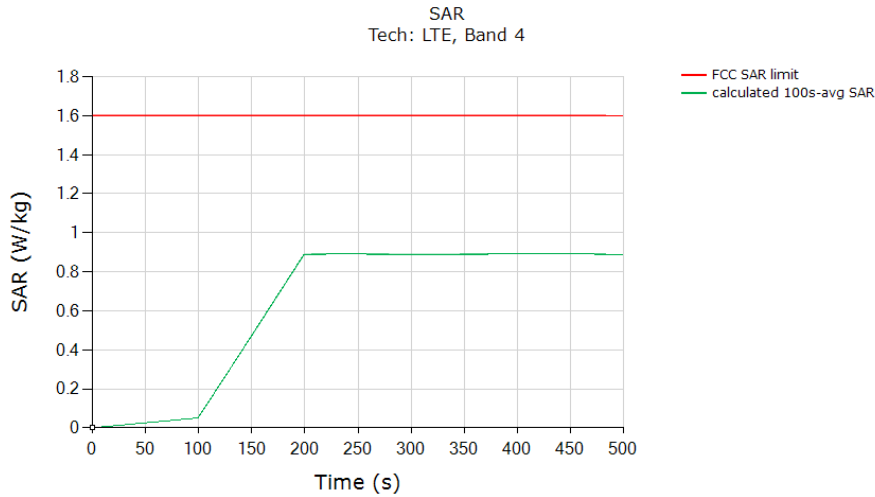

FCC Limit for 1gSAR (W/kg)	1.6
Max. Time-Averaged 1gSAR in Green Curve (W/kg)	0.891
Validated: Max time-averaged SAR in green curve is within 1 dB device uncertainty of measured SAR at <i>Plimit</i> (last column in Table 5-2).	

<Test Result for Test Sequence 2>

Time-averaged conducted Tx power is converted / calculated into time-averaged 1gSAR using Equation (1) and plotted below to demonstrate that the time-averaged 1gSAR versus time does not exceed the FCC limit of 1.6 W/kg for 1gSAR:

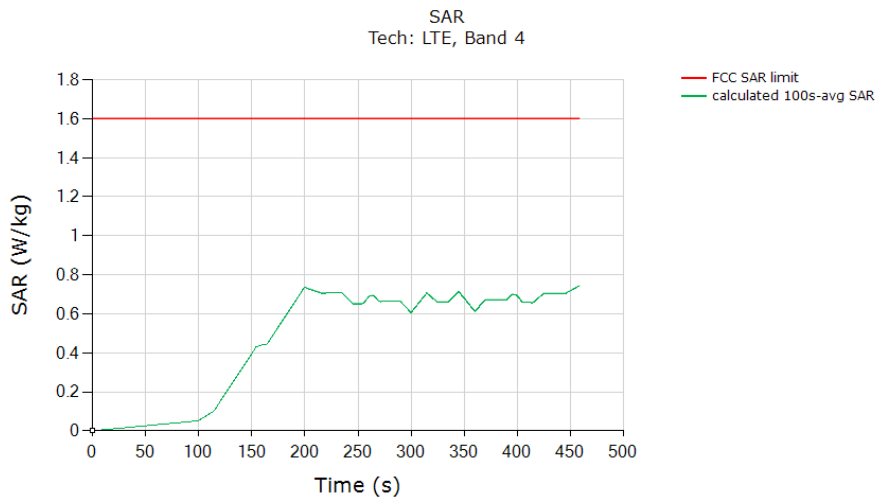

FCC Limit for 1gSAR (W/kg)	1.6
Max. Time-Averaged 1gSAR in Green Curve (W/kg)	0.743
Validated: Max time-averaged SAR in green curve is within 1 dB device uncertainty of measured SAR at <i>Plimit</i> (last column in Table 5-2).	

Sub-6 NR n25 SA:

<Test Result for Test Sequence 1>

Time-averaged conducted Tx power is converted / calculated into time-averaged 1gSAR using Equation (1) and plotted below to demonstrate that the time-averaged 1gSAR versus time does not exceed the FCC limit of 1.6 W/kg for 1gSAR:

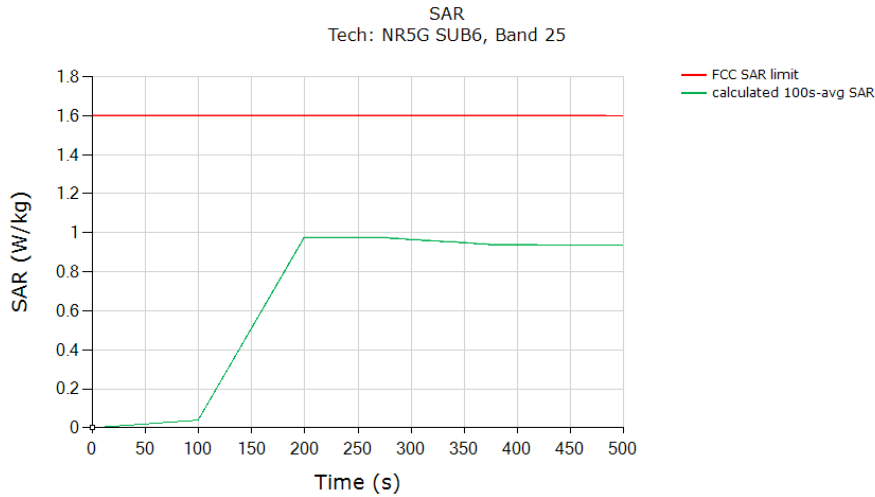

FCC Limit for 1gSAR (W/kg)	1.6
Max. Time-Averaged 1gSAR in Green Curve (W/kg)	0.976
Validated: Max time-averaged SAR in green curve is within 1 dB device uncertainty of measured SAR at <i>Plimit</i> (last column in Table 5-2).	

<Test Result for Test Sequence 2>

Time-averaged conducted Tx power is converted / calculated into time-averaged 1gSAR using Equation (1) and plotted below to demonstrate that the time-averaged 1gSAR versus time does not exceed the FCC limit of 1.6 W/kg for 1gSAR:

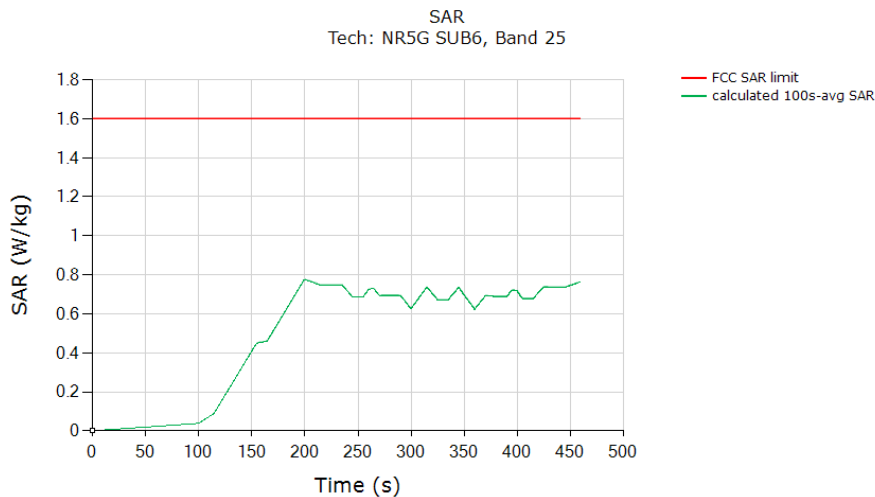

FCC Limit for 1gSAR (W/kg)	1.6
Max. Time-Averaged 1gSAR in Green Curve (W/kg)	0.774
Validated: Max time-averaged SAR in green curve is within 1 dB device uncertainty of measured SAR at <i>Plimit</i> (last column in Table 5-2).	

5.4. Test Result for Call Drop

This test was measured with **LTE Band 38, Antenna Main, DSI=0**, and with callbox requesting maximum power. The call drop was manually performed when the DUT is transmitting at *Preserve* level as shown in the plot below. The measurement setup is shown in Figure 4-4. The detailed test procedure is described in Section 4.3.2.

Plot 1: Measured Tx power (dBm) versus time shows that the transmitting power kept the same *Preserve* level of **LTE Band 38** after the call was re-established.

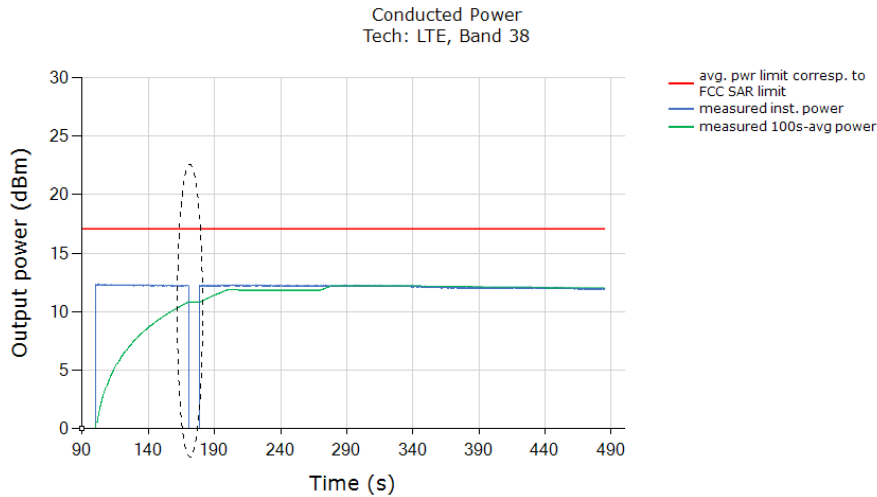

Plot 2: Time-averaged conducted Tx power is converted / calculated into time-averaged 1gSAR using Equation (1) and plotted below to demonstrate that the time-averaged 1gSAR versus time does not exceed the FCC limit of 1.6 W/kg for 1gSAR:

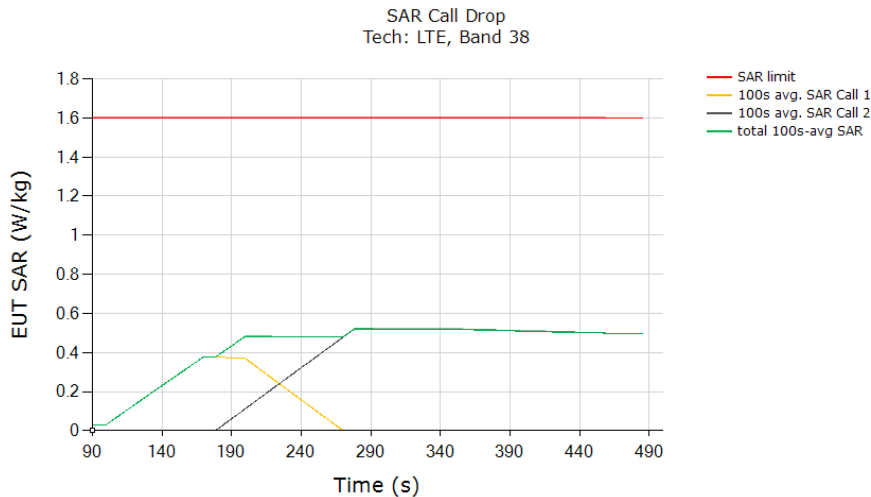

FCC Limit for 1gSAR (W/kg)	1.6
Max. Time-Averaged 1gSAR in Green Curve (W/kg)	0.52
Validated	

The test result validated the continuity of power limiting in call change scenario.

5.5. Test Result for Change in Technology / Band

This test was conducted with callbox requesting maximum power, and with a technology switch from **LTE Band 43, Antenna MIMO 1** to **WCDMA Band 4, Antenna Main**. Following procedure detailed in Section 4.3.3, and using the measurement setup shown in Figure 4-4, the technology / band switch was performed when the DUT is transmitting at *Preserve* level as shown in the plot below.

Plot 1: Measured Tx power (dBm) versus time shows that the transmitting power changed from **LTE Band 43, Antenna MIMO 1 Preserve** level to **WCDMA Band 4, Antenna Main Preserve** level (within 1 dB device uncertainty).

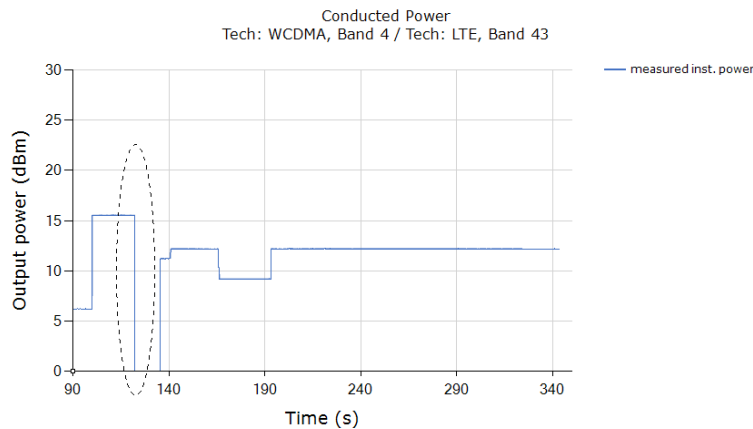

Plot 2: All the time-averaged conducted Tx power measurement results were converted into time-averaged normalized SAR values using Equation (13), (14) and (15), and plotted below to demonstrate that the time-averaged normalized SAR versus time does not exceed the normalized FCC limit of 1.0.

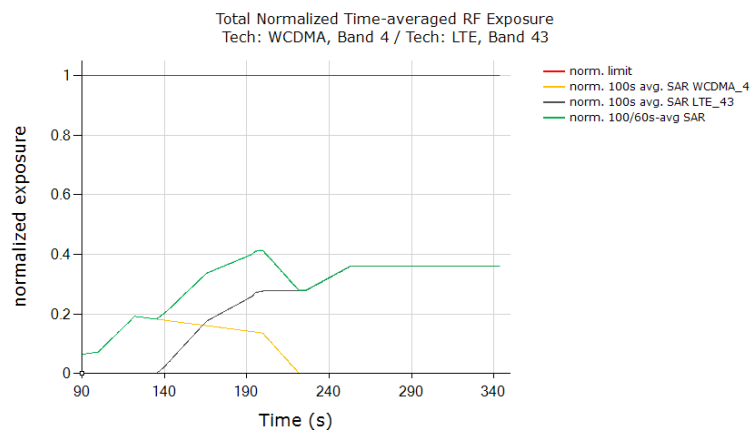

FCC Normalized SAR Limit	1.0
Max. Time-Averaged Normalized SAR in Green Curve	0.413
Validated	

The test result validated the continuity of power limiting in technology / band switch scenario.

5.6. Test Result for Change in Time-Window Switch

This test was conducted with callbox requesting maximum power, and with time-window / antenna switch between **LTE Band 4, Antenna Main** (100s window) and **LTE Band 43, Antenna MIMO 1** (60s window). Following procedure detailed in Section 4.3.6, and using the measurement setup shown in Figure 4-5, the time-window switch via tech / band / antenna switch was performed when the DUT is transmitting at *Preserve* level.

<Test Case 1: Transition from LTE B4 to LTE B43, then back to LTE B4 (from 100s to 60s to 100s)>

Plot 1: Measured Tx power (dBm) versus time shows that the transmitting power changed when **LTE Band 4** switches to **LTE Band 43** (~245s timestamp) and switches back to **LTE band 4** (~320s timestamp).

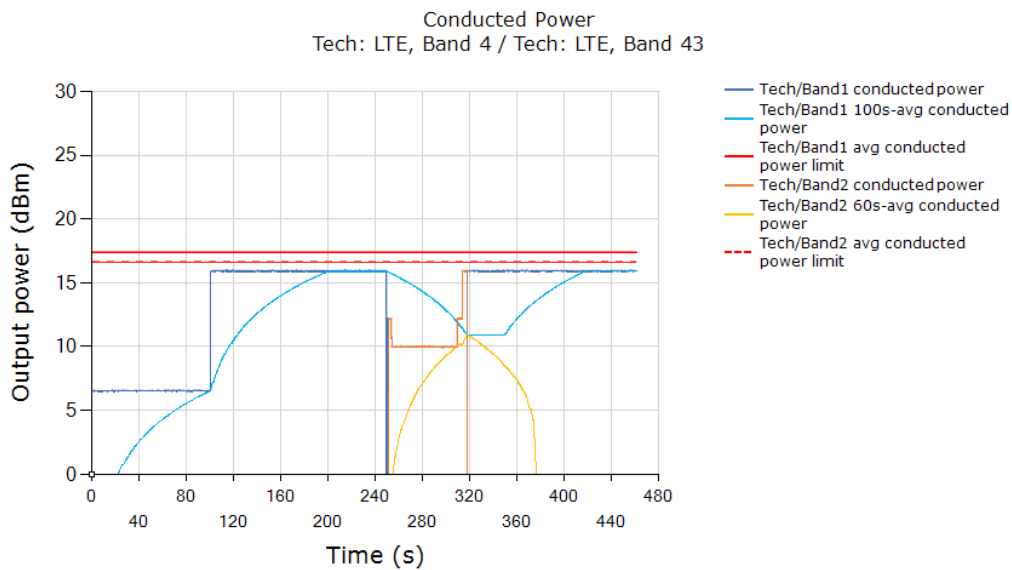

Plot Notes: The conducted power plot shows expected transitions in Tx power at ~245 seconds (100s to 60s transition) and at ~320 seconds (60s to 100s transition) in order to maintain total time-averaged RF exposure compliance across time-windows, as show in next plot.

Plot 2: All the conducted Tx power measurement results were converted into time-averaged normalized SAR values using Equation (16), (17) and (18), and plotted below to demonstrate that the time-averaged normalized SAR versus time does not exceed the FCC limit of 1. Equation (16) is used to convert the Tx power of device to obtain 100s-averaged normalized SAR in **LTE Band 4** as shown in black curve. Similarly, equation (17) is used to obtain 60s-averaged normalized SAR in **LTE Band 43** as shown in orange curve. Equation (18) is used to obtain total time-averaged normalized SAR as shown in green curve (i.e., sum of black and orange curves).

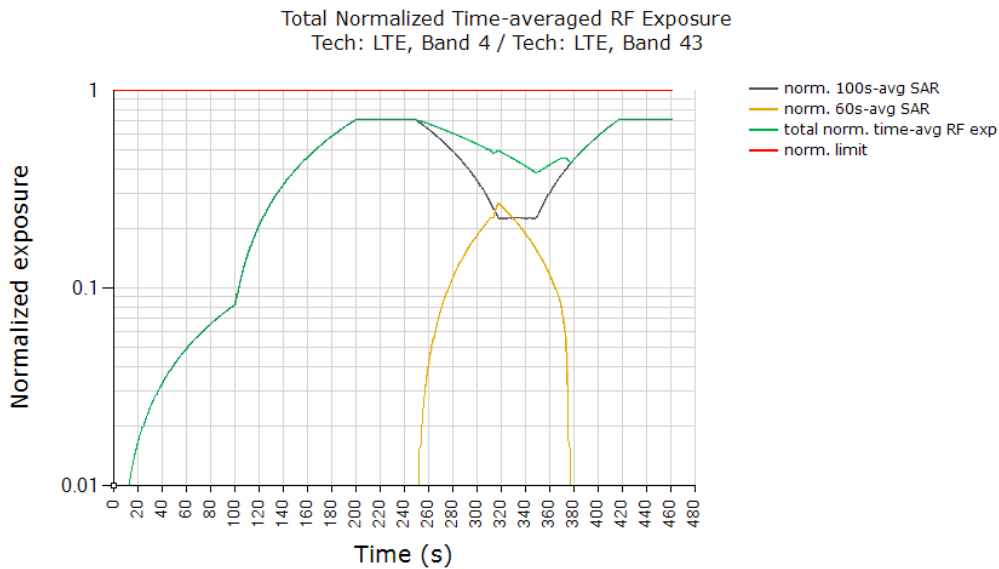

FCC Limit for Total RF Exposure (Normalized)	1.0
Max. Time-Averaged Normalized SAR in Green Curve	0.711
Validated	

Plot Notes: Maximum power is requested by callbox for the entire duration of the test, with tech / band switches from 100s to 60s window at ~245s timestamp, and from 60s to 100s window at ~320s timestamp. Smart Transmit controls the Tx power during these time-window switches to ensure total time-averaged RF exposure (i.e., sum of black and orange curves given by equation (18)) is always compliant. In time-window switch test, at all times the total time-averaged normalized RF exposure (green curve) should not exceed normalized *SAR_design_target* + 1 dB device uncertainty. In this test, with a maximum normalized SAR of 0.711 being ≤ 0.75 ($= 0.95 / 1.6 + 1$ dB device uncertainty), the above test result validated the continuity of power limiting in time-window switch scenario.

<Test Case 2: Transition from LTE B43 to LTE B4, then back to LTE B43 (from 60s to 100s to 60s)>

Plot 1: Measured Tx power (dBm) versus time shows that the transmitting power changed when **LTE Band 43** switches to **LTE Band 4** (~200s timestamp) and switches back to **LTE band 43** (~300s timestamp).

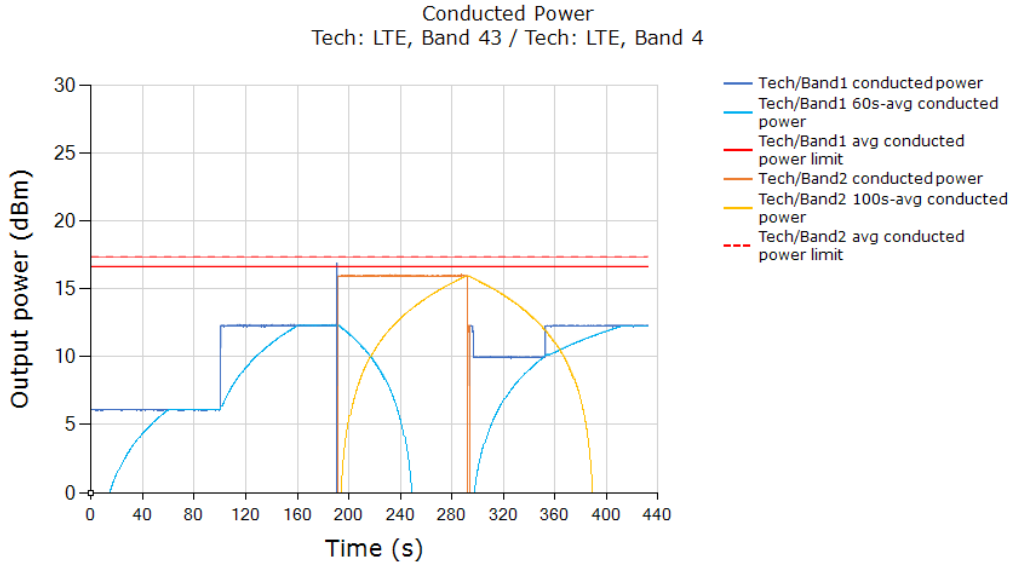

Plot Notes: The conducted power plot shows expected transitions in Tx power at ~200 seconds (60s to 100s transition) and at ~300 seconds (100s to 60s transition) in order to maintain total time-averaged RF exposure compliance across time-windows, as show in next plot.

Plot 2: All the conducted Tx power measurement results were converted into time-averaged normalized SAR values using Equation (16), (17) and (18), and plotted below to demonstrate that the time-averaged normalized SAR versus time does not exceed the FCC limit of 1. Equation (16) is used to convert the Tx power of device to obtain 100s-averaged normalized SAR in **LTE Band 43** as shown in black curve. Similarly, equation (17) is used to obtain 60s-averaged normalized SAR in **LTE Band 4** as shown in orange curve. Equation (18) is used to obtain total time-averaged normalized SAR as shown in green curve (i.e., sum of black and orange curves).

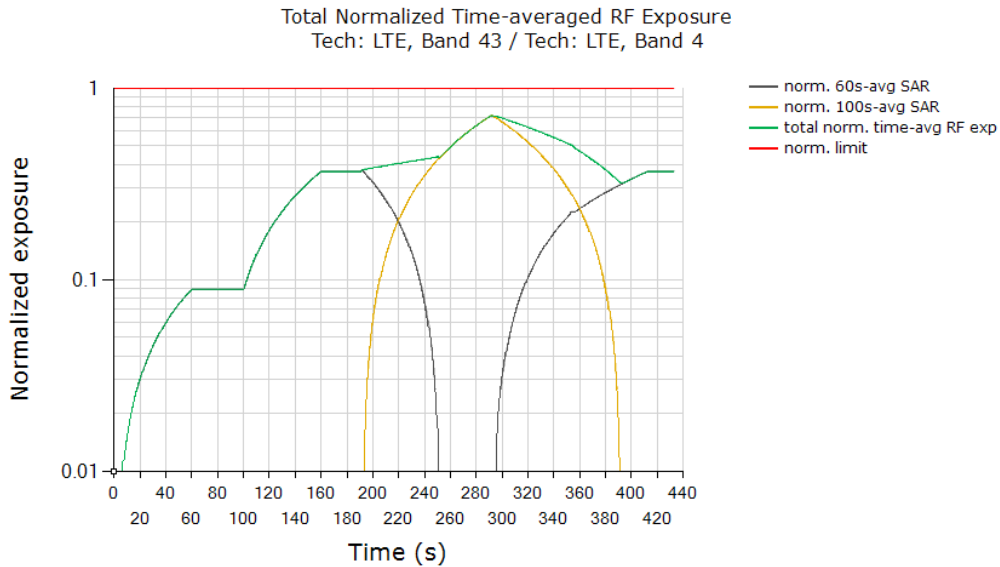

FCC Limit for Total RF Exposure (Normalized)	1.0
Max. Time-Averaged Normalized SAR in Green Curve	0.72
Validated	

Plot Notes: Maximum power is requested by callbox for the entire duration of the test, with tech / band switches from 60s to 100s window at ~200s timestamp, and from 100s to 60s window at ~300s timestamp. Smart Transmit controls the Tx power during these time-window switches to ensure total time-averaged RF exposure (i.e., sum of black and orange curves given by equation (18)) is always compliant. In time-window switch test, at all times the total time-averaged normalized RF exposure (green curve) should not exceed normalized *SAR_design_target* + 1 dB device uncertainty. In this test, with a maximum normalized SAR of 0.72 being ≤ 0.75 ($= 0.95 / 1.6 + 1$ dB device uncertainty), the above test result validated the continuity of power limiting in time-window switch scenario.

5.7. Test Result for Switch in SAR Exposure

This test was conducted with callbox requesting maximum power, and with the DUT in **LTE Band 2 + Sub-6 NR Band n71** call. Following procedure detailed in Section 4.3.7 and using the measurement setup shown in Figure 4-6 since LTE and Sub-6 NR are sharing the same antenna, the SAR exposure switch measurement is performed with the DUT in various SAR exposure scenarios (i.e., in SARSub6NR only scenario (t = 0s to 120s), SARSub6NR + SARLTE scenario (t = 120s to 240s) and SARLTE only scenario (t > 240s)).

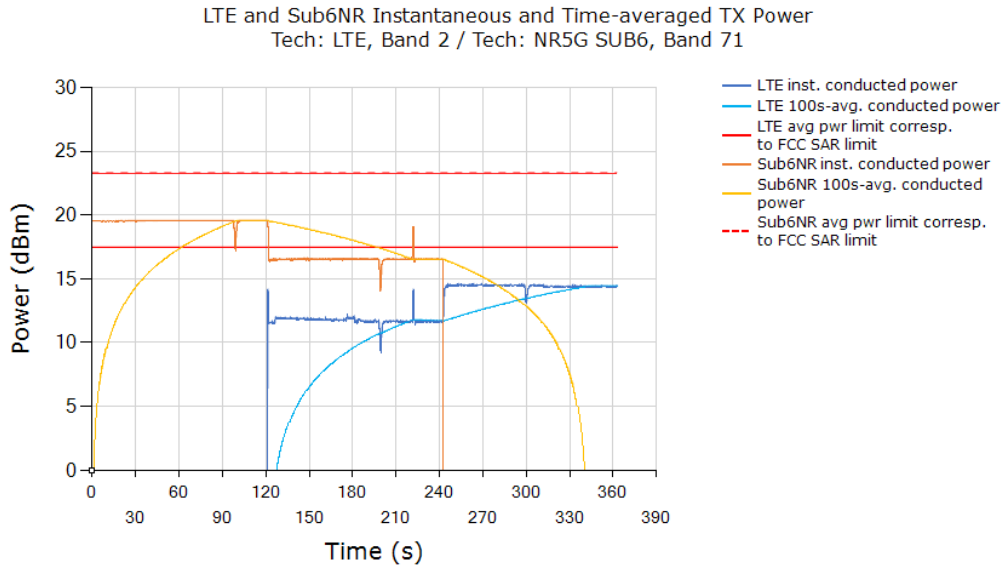

Plot Notes: All the conducted Tx power measurement results were converted into time-averaged normalized SAR values using Equation (16), (17) and (18), and plotted below to demonstrate that the time-averaged normalized SAR versus time does not exceed the FCC limit of 1. Equation (16) is used to convert the LTE Tx power of device to obtain 100s-averaged normalized SAR in **LTE Band 2** as shown in black curve. Similarly, equation (17) is used to obtain 100s-averaged normalized SAR in **Sub-6 NR n71** as shown in orange curve. Equation (18) is used to obtain total time-averaged normalized SAR as shown in green curve (i.e., sum of black and orange curves).

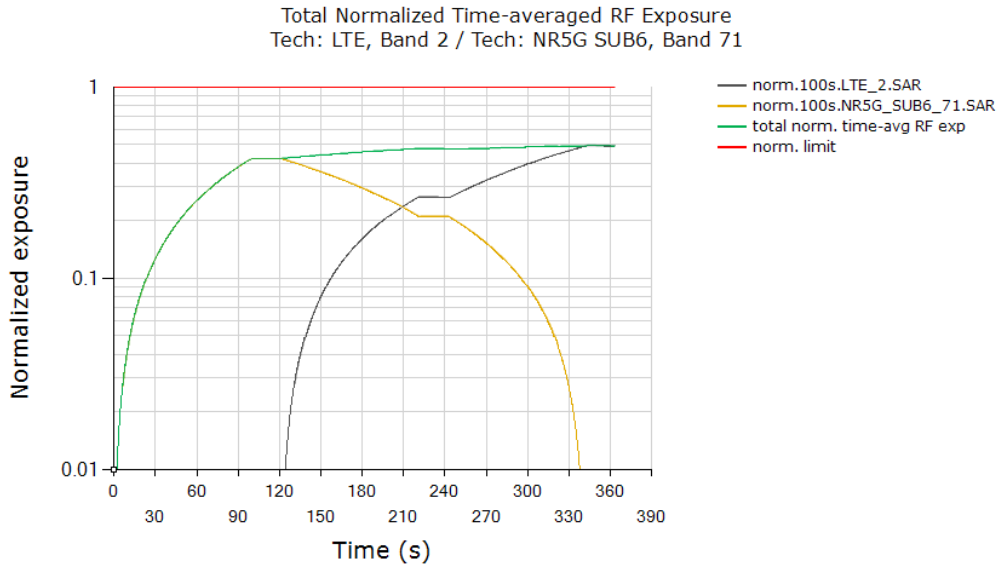

FCC Limit for Total RF Exposure (Normalized)	1.0
Max. Time-Averaged Normalized SAR in Green Curve	0.494
Validated	

Plot Notes: Device starts predominantly in Sub-6 NR SAR exposure scenario between 0s and 120s, and in LTE SAR + Sub-6 NR SAR exposure scenario between 120s and 240s, and in predominantly in LTE SAR exposure scenario after t = 240s. Here, Smart Transmit allocates a maximum of 100% of exposure margin (based on 3 dB reserve margin setting) for Sub-6 NR. This corresponds to a normalized 1gSAR exposure value = 100% x 0.826 W/kg measured SAR at Sub-6 NR *P*_{limit} / 1.6 W/kg limit = 0.516 ± 1 dB device related uncertainty (see orange curve between 0s and 120s). For predominantly LTE SAR exposure scenario, maximum normalized 1gSAR exposure should correspond to 100 % exposure margin = 0.949 W/kg measured SAR at LTE *P*_{limit} / 1.6 W/kg limit = 0.593 ± 1 dB device related uncertainty (see black curve after t = 240s). Additionally, in SAR exposure switch test, at all times the total time-averaged normalized RF exposure (green curve) should not exceed normalized SAR_{design_target} + 1 dB device uncertainty. In this test, with a maximum normalized SAR of 0.494 being ≤ 0.75 (= 0.95 / 1.6 + 1 dB device uncertainty), the above test result validated the continuity of power limiting in SAR exposure switch scenario.

5.8. Test Result for Time-varying SAR

Following Section 4.4 procedure, time-averaged SAR measurements are conducted using a SAR probe at peak location of area scan over 500 seconds. SAR probe integration times depend on the communication signal being tested as defined in the probe calibration parameters.

Since the sampling rate used by DASY8 for pointSAR measurements is not in user control, the number of points in 100s interval is determined from the scan duration setting in DASY8 time-average pointSAR measurement by (*Total Number of pointSAR * 100s DASY8 Scan Time Duration*). Running average is performed over these number of points in excel spreadsheet to obtain 100s-averaged pointSAR.

Following Section 4.4, for each of selected technology / band (listed in Table 5-2):

1. With *Reserve_power_margin* set to 0 dB, area scan is performed at *Plimit*, and time-averaged pointSAR measurements are conducted to determine the pointSAR at *Plimit* at peak location, denoted as *pointSARPlimit*.
2. With *Reserve_power_margin* set to actual (intended) value, two more time-averaged pointSAR measurements are performed at the same peak location for test sequences 1 and 2.

To demonstrate compliance, all the pointSAR measurement results were converted into 1gSAR or 10gSAR values by using Equation (6), re-written below:

$$1g_or_10gSAR(t) = \frac{pointSAR(t)}{pointSAR_{Plimit}} * 1g_or_10gSAR_{Plimit} \quad (6)$$

where, *pointSAR(t)*, *pointSARPlimit*, and *1g_or_10gSAR_Plimit* correspond to the measured instantaneous point SAR, measured point SAR at *Plimit* from above step 1 and 2, and measured 1gSAR or 10gSAR values at *Plimit* obtained from *Part 1* report and listed in Table 5-2 of this report.

DASY8 System Verification for SAR Measurement

<Tissue Verification>

The dielectric properties of the tissue simulating liquid have been measured within 24 hours before the SAR testing and within $\pm 10\%$ of the target values. Liquid temperature during the SAR testing has kept within $\pm 2^\circ\text{C}$.

Test Results for Tissue Simulating Liquid

Frequency (MHz)	Liquid Temp. ($^\circ\text{C}$)	Permittivity (ϵ_r)	Conductivity (σ)	Permittivity Target (ϵ_r)	Conductivity Target (σ)	Permittivity Deviation (%)	Conductivity Deviation (%)	Testing Date
1800	22.5	40.3	1.33	40.0	1.40	0.7	-5.0	Feb. 02, 2024
1800	21.3	42.1	1.38	40.0	1.40	5.3	-1.4	Feb. 07, 2024

<Test System Verification>

Before time-averaged SAR measurements, DASY8 system has been verified. The result normalized to 1W comparing to the reference SAR value provided by SPEAG in dipole calibration certificate, the deviation of system check results is within its specification of 10%. The below test results indicate the system check can meet the variation criterion.

Figure 6-1: System Verification Setup

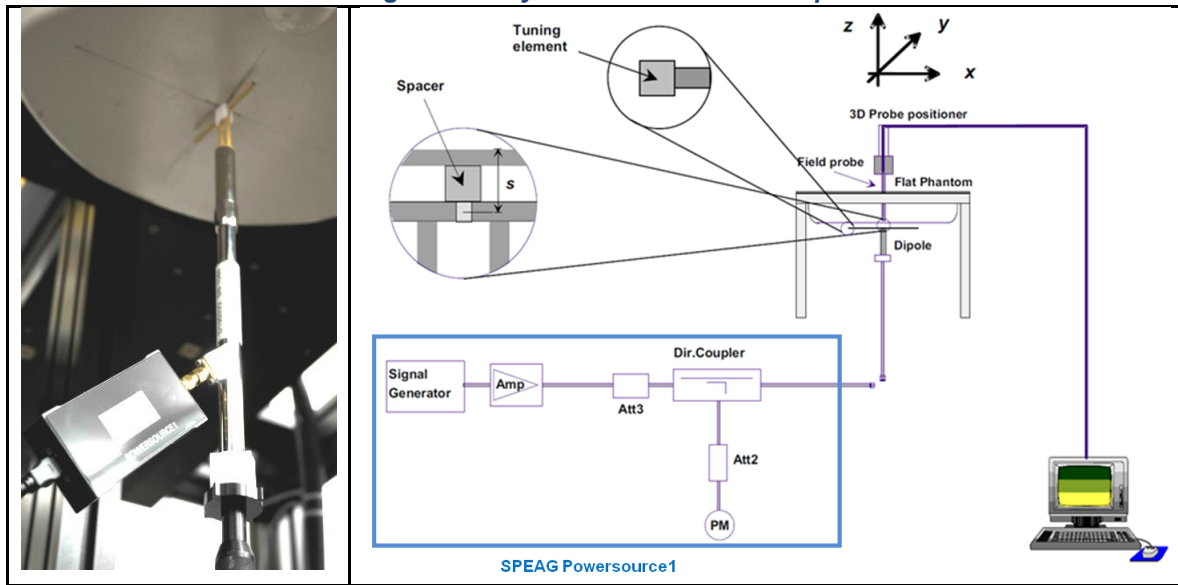

Test Results for System Verification

Date	Frequency (MHz)	Targeted 1g SAR (W/kg)	Measured 1g SAR (W/kg)	Normalized 1g SAR (W/kg)	Deviation (%)	Dipole S/N	Probe S/N	DAE S/N
Feb. 02, 2024	1800	38.0	1.82	36.31	-4.4	2d167	7650	1741
Feb. 07, 2024	1800	38.0	1.86	37.11	-2.3	2d167	7650	1741

WCDMA Band 4:

<SAR Test Result for Test Sequence 1>

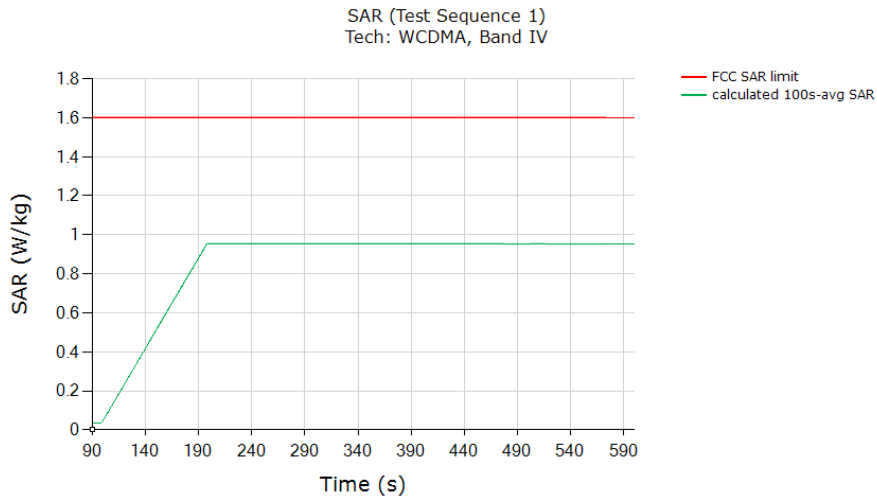

FCC Limit for 1gSAR (W/kg)	1.6
Max. Time-Averaged 1gSAR in Green Curve (W/kg)	0.953
Validated: Max time-averaged SAR in green curve is within 1 dB device uncertainty of measured SAR at <i>Plimit</i> (last column in Table 5-2).	

<SAR Test Result for Test Sequence 2>

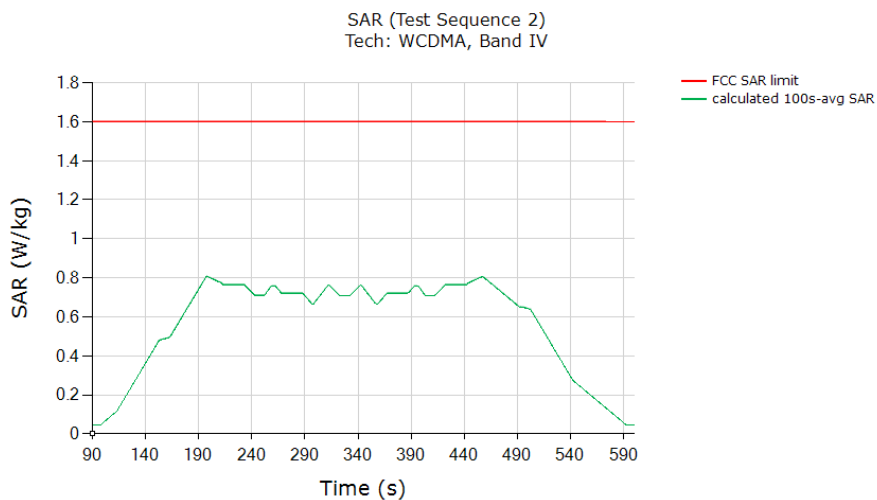

FCC Limit for 1gSAR (W/kg)	1.6
Max. Time-Averaged 1gSAR in Green Curve (W/kg)	0.806
Validated: Max time-averaged SAR in green curve is within 1 dB device uncertainty of measured SAR at <i>Plimit</i> (last column in Table 5-2).	

LTE Band 4:

<SAR Test Result for Test Sequence 1>

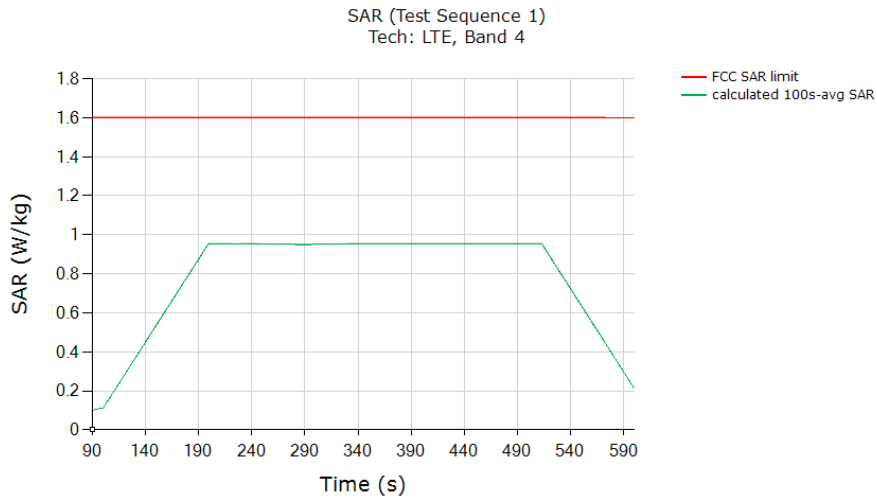

FCC Limit for 1gSAR (W/kg)	1.6
Max. Time-Averaged 1gSAR in Green Curve (W/kg)	0.953
Validated: Max time-averaged SAR in green curve is within 1 dB device uncertainty of measured SAR at <i>Plimit</i> (last column in Table 5-2).	

<SAR Test Result for Test Sequence 2>

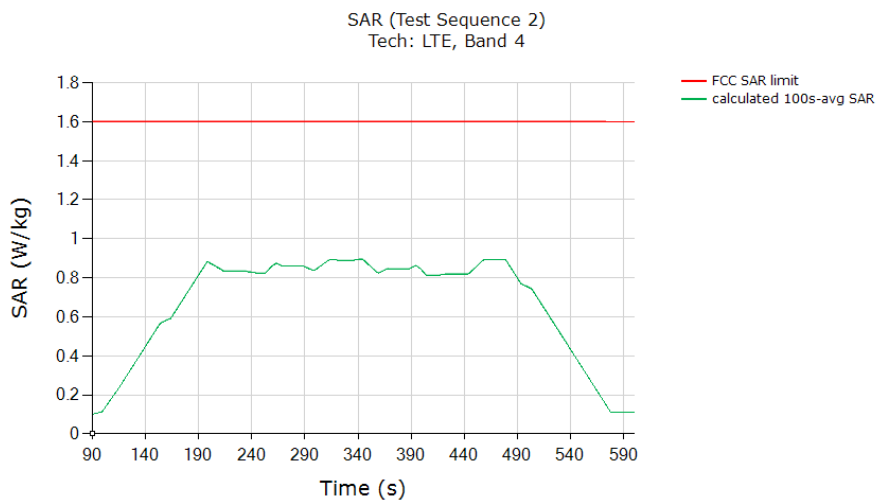

FCC Limit for 1gSAR (W/kg)	1.6
Max. Time-Averaged 1gSAR in Green Curve (W/kg)	0.895
Validated: Max time-averaged SAR in green curve is within 1 dB device uncertainty of measured SAR at <i>Plimit</i> (last column in Table 5-2).	

Sub-6 NR n25 SA:

<SAR Test Result for Test Sequence 1>

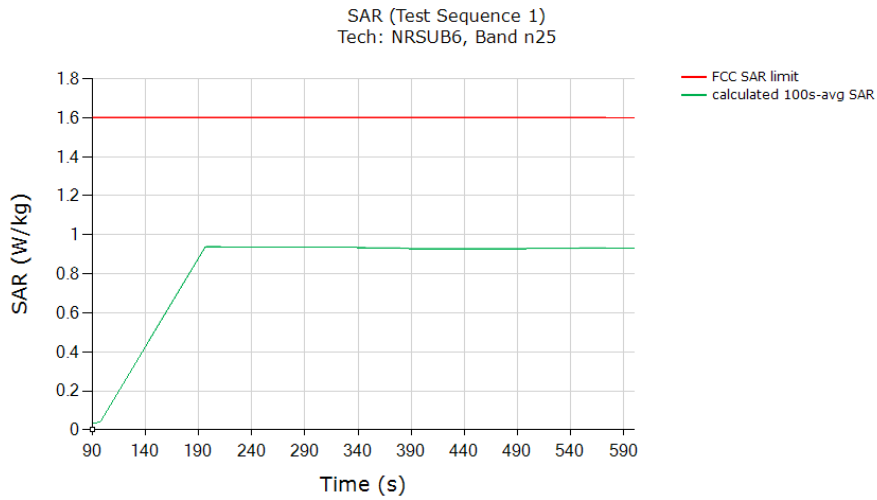

FCC Limit for 1gSAR (W/kg)	1.6
Max. Time-Averaged 1gSAR in Green Curve (W/kg)	0.936
Validated: Max time-averaged SAR in green curve is within 1 dB device uncertainty of measured SAR at <i>Plimit</i> (last column in Table 5-2).	

<SAR Test Result for Test Sequence 2>

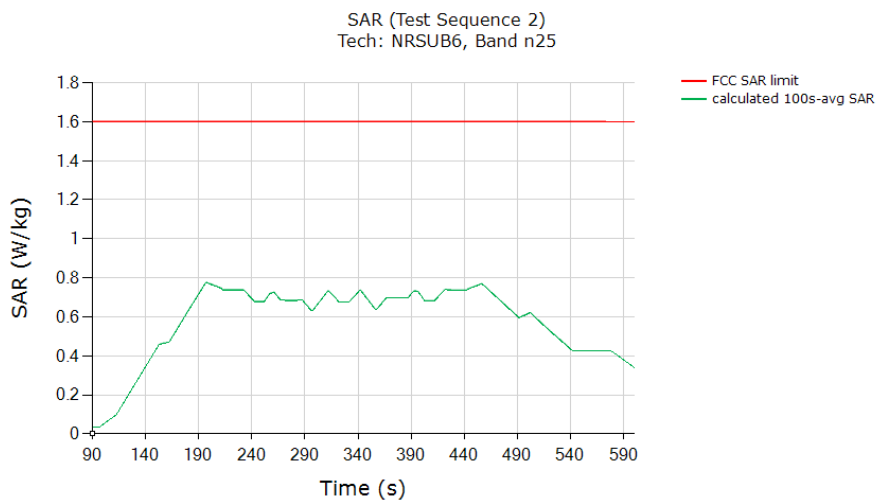

FCC Limit for 1gSAR (W/kg)	1.6
Max. Time-Averaged 1gSAR in Green Curve (W/kg)	0.774
Validated: Max time-averaged SAR in green curve is within 1 dB device uncertainty of measured SAR at <i>Plimit</i> (last column in Table 5-2).	

6. Conclusions for Time-Averaging Feature Validation

The Qualcomm Smart Transmit employed in this device has been validated through the conducted power measurement and SAR measurement (as demonstrated in Chapter 5).

With the combination of the **Part 0: Evaluation Report for SAR Char** for Qualcomm Smart Transmit, **Part 1: SAR Evaluation Report (Test Under Static Transmission Scenario)** for FCC equipment authorization, and this **Part 2: RF Exposure Evaluation Report (Test Under Dynamic Transmission Condition)** for time-averaging feature validation, it can be concluded that the time-averaged RF exposure for this device is compliant with the FCC limits in all transmission scenarios for all the supported radios.

7. Equipment List

Manufacturer	Equipment	Model No.	Serial No.	Cal. Date	Cal. Interval
SPEAG	1800 MHz System Validation Kit	D1800V2	2d167	Jul. 12, 2023	1 year
SPEAG	Dosimetric E-Field Probe	EX3DV4	7650	May 22, 2023	1 year
SPEAG	Data Acquisition Electronics	DAE4	1741	Aug. 23, 2023	1 year
SPEAG	Dielectric Probe Kit	DAKS-3.5	1158	Dec. 11, 2023	1 year
SPEAG	POWERSOURCE1	SE UMS 160 CA	4283	Aug. 16, 2023	1 year
R&S	Wireless Communication Test Set	CMW500	170768	Nov. 30, 2022	2 years
Anritsu	Radio Communication Analyzer	MT8821C	6272459653	Aug. 16, 2023	1 year
Anritsu	Radio Communication Analyzer	MT8000	6272466193	Aug. 16, 2023	1 year
R&S	Power Sensor	NRP8S	111511	Nov. 30, 2023	1 year
R&S	Power Sensor	NRP8S	111512	Nov. 30, 2023	1 year
Woken	Directional Coupler	0110A05801M-10	N/A	CBT	N/A
Woken	Directional Coupler	0110A05801M-10	N/A	CBT	N/A

Note: CBT (Calibrated Before Testing). Prior to testing, the measurement paths containing a cable, attenuator, coupler, or filter were connected to a calibrated source to determine the losses of the measurement path. The power meter offset was then adjusted to compensate for the measurement system losses. This level offset is stored within the power meter before measurements are made. This calibration verification procedure applies to output power measurements. The calibrated reading is then taken directly from the power meter after compensation of the losses for all final power measurements.

Test Engineer : Raymond Wu

***** End of Report *****