

RF Test Report

Applicant : Getac Technology Corporation
 Product Name : Wireless Module
 Trade Name : Getac
 Model Number : EM7511U
 Applicable Standard : FCC 47 CFR PART 22H
 FCC 47 CFR PART 24E
 FCC 47 CFR PART 27
 FCC 47 CFR PART 90
 ANSI C63.26 2015
 Received Date : Oct. 13, 2022
 Test Period : Nov. 08, 2022
 Issued Date : Jan. 04, 2023

Issued by

Eurofins E&E Wireless Taiwan Co., Ltd.
 No. 140-1, Changan Street, Bade District,
 Taoyuan City 334025, Taiwan (R.O.C.)
 Tel : +886-3-2710188 / Fax : +886-3-2710190



Taiwan Accreditation Foundation accreditation number: 1330

Frequency Range : 9 kHz to 40 GHz

Test Firm MRA designation number: TW0010

Note:

- 1.The test results are valid only for samples provided by customers and under the test conditions described in this report.
- 2.This report shall not be reproduced except in full, without the written approval of Eurofins E&E Wireless Taiwan Co., Ltd.
- 3.The relevant information is provided by customers in this test report. According to the correctness, appropriateness or completeness of the information provided by the customer, if there is any doubt or error in the information which affects the validity of the test results, the laboratory does not take the responsibility.

Revision History

Version	Issued Date	Revisions	Revised By
00	Dec. 23, 2022	Initial Issue	Snow Wang
01	Jan. 04, 2023	Update chapter 1.3 (P.7)	Snow Wang

Verification of Compliance

Applicant : Getac Technology Corporation

Product Name : Wireless Module

Trade Name : Getac

Model Number : EM7511U

FCC ID : QYLEM7511U

Applicable Standard : FCC 47 CFR PART 22H
FCC 47 CFR PART 24E
FCC 47 CFR PART 27
FCC 47 CFR PART 90
ANSI C63.26 2015

Test Result : Complied

Performing Lab. : Eurofins E&E Wireless Taiwan Co., Ltd.
No. 140-1, Changan Street, Bade District,
Taoyuan City 334025, Taiwan (R.O.C.)
Tel : +886-3-2710188 / Fax : +886-3-2710190
Taiwan Accreditation Foundation accreditation number: 1330



Eurofins E&E Wireless Taiwan Co., Ltd. tested the above equipment in accordance with the requirements set forth in the above standards. All indications of Pass/Fail in this report are opinions expressed by Eurofins E&E Wireless Taiwan Co., Ltd. based on interpretations and/or observations of test results. The test results show that the equipment tested is capable of demonstrating compliance with the requirements as documented in this report.

Approved By : _____

TABLE OF CONTENTS

1	General Information.....	5
1.1.	EUT Description	5
1.2.	Testing Location	7
1.3.	Mode of Operation	7
1.4.	EUT Test Step	8
1.5.	Configuration of Test System Details	8
1.6.	Test Instruments.....	9
1.7.	Test Site Environment	10
1.8.	Measurement Uncertainty	10
1.9.	Summary of Test Result	11
2	Measurement Procedure.....	12
2.1.	Radiated Emission Test.....	12
3	Test Results	14
3.1.	Radiated Emission	14

Appendix A. Test Setup Photographs

1 General Information

1.1. EUT Description

Applicant	Getac Technology Corporation 5F.,Building A,No.209,Sec.1 Nangang.,Rd., Taipei City, 11568, Taiwan		
Product Name	Wireless Module		
Trade Name	Getac		
Model Number	EM7511U		
FCC ID	QYLEM7511U		
Host Information	Product Name: Tablet Trade Name: Getac Model Name: UX10, UX10G3, UX10-301, UX10-321, UX10-Ex, UX10Y(Y= 10 characters, Y can be 0 to 9, A to Z, a to z, “/”, “\”, “-”, “_” or blank for marketing purpose) (Different model numbers are for market purpose.)		
IMEI No.	351664100388162		
Operate Band	Frequency Range (MHz)	Modulation	Channel Bandwidth
LTE Band 2	UL: 1850 ~ 1910	QPSK, 16QAM	1.4 MHz, 3 MHz, 5 MHz, 10 MHz, 15 MHz, 20 MHz
	DL: 1930 ~ 1990	QPSK, 16QAM	
LTE Band 4	UL: 1710 ~ 1755	QPSK, 16QAM	1.4 MHz, 3 MHz, 5 MHz, 10 MHz, 15 MHz, 20 MHz
	DL: 2110 ~ 2155	QPSK, 16QAM	
LTE Band 5	UL: 824 ~ 849	QPSK, 16QAM	1.4 MHz, 3 MHz, 5 MHz, 10 MHz
	DL: 869 ~ 894	QPSK, 16QAM	
LTE Band 7	UL: 2500 ~ 2570	QPSK, 16QAM	5 MHz, 10 MHz, 15 MHz, 20 MHz
	DL: 2620 ~ 2690	QPSK, 16QAM	
LTE Band 12	UL: 699 ~ 716	QPSK, 16QAM	1.4 MHz, 3 MHz, 5 MHz, 10 MHz
	DL: 728 ~ 746	QPSK, 16QAM	
LTE Band 13	UL: 777 ~ 787	QPSK, 16QAM	5 MHz, 10 MHz
	DL: 746 ~ 756	QPSK, 16QAM	
LTE Band 14	UL: 788 ~ 798	QPSK, 16QAM	5 MHz, 10 MHz
	DL: 758 ~ 768	QPSK, 16QAM	
LTE Band 26(Part 22)	UL: 824 ~ 849	QPSK, 16QAM	1.4 MHz, 3 MHz, 5 MHz, 10 MHz, 15 MHz
	DL: 869 ~ 894	QPSK, 16QAM	
LTE Band 26(Part 90S)	UL: 814.7 ~ 823.3	QPSK, 16QAM	1.4 MHz, 3 MHz, 5 MHz, 10 MHz
	DL: 859.7 ~ 868.3	QPSK, 16QAM	
LTE Band 41	UL/DL: 2496 ~ 2690	QPSK, 16QAM	5 MHz, 10 MHz, 15 MHz, 20 MHz
LTE Band 66	UL: 1710 ~ 1780	QPSK, 16QAM	1.4 MHz, 3 MHz, 5 MHz, 10 MHz, 15 MHz, 20 MHz
	DL: 2110 ~ 2200	QPSK, 16QAM	

Antenna information	Antenna	Type	Max. Gain (dBi)	
	Main	FPC Antenna	LTE Band 2	2.76
LTE Band 4			2.00	
LTE Band 5			0.08	
LTE Band 7			2.73	
LTE Band 12			0.43	
LTE Band 13			0.51	
LTE Band 14			0.73	
LTE Band 26			0.37	
LTE Band 41			2.93	
LTE Band 66			2.16	
AUX	FPC Antenna	LTE Band 2	-3.25	
		LTE Band 4	-0.57	
		LTE Band 5	1.65	
		LTE Band 7	1.03	
		LTE Band 12	0.93	
		LTE Band 13	1.36	
		LTE Band 14	1.01	
		LTE Band 26	1.31	
LTE Band 41	1.02			
LTE Band 66	-0.36			
Operate Temp. Range	-10 ~ 55 °C			
EUT Power Rating	DC 3.3 V			

EUT Modify Description :

Modify Description: 1. Added Host Model: UX10, UX10G3, UX10-301, UX10-321, UX10-Ex, UX10Y(Y= 10 characters, Y can be 0 to 9, A to Z, a to z, “/”, “\”, “-”, “_” or blank for marketing purpose) 2. Disable Band 48 by software After our evaluation, the retest of Simultaneous Transmission of Field Strength of Spurious Radiation is required. The other test data refer to the original report.
--

1.2. Testing Location

Lab Name: Eurofins E&E Wireless Taiwan Co., Ltd.

Site Address: No. 140-1, Changan Street, Bade District, Taoyuan City 334025, Taiwan (R.O.C.)

Site Address: No. 2, Wuquan 5th Rd. Wugu Dist., New Taipei City, Taiwan (R.O.C.)

1.3. Mode of Operation

Three channels had been tested for each channel bandwidth.

LTE Band 41				
Channel Bandwidth	5 MHz		10 MHz	
	Channel	Frequency (MHz)	Channel	Frequency (MHz)
Low CH	39675	2498.5	39700	2501.0
Middle CH	40620	2593.0	40620	2593.0
High CH	41565	2687.5	41540	2685.0
Channel Bandwidth	15 MHz		20 MHz	
	Channel	Frequency (MHz)	Channel	Frequency (MHz)
Low CH	39725	2503.5	39750	2506.0
Middle CH	40620	2593.0	40620	2593.0
High CH	41515	2682.5	41490	2680.0

By preliminary testing and verifying three axis (X, Y and Z) position of EUT transmitted status, it was found that "Y axis" position was the worst, then the final test was executed the worst condition and test data were recorded in this report.

1.4. EUT Test Step

1	Setup the EUT by "Configuration of Test System Details" shown below.
2	Turn on the power of all equipment.
3	The EUT was programmed to be in continuously transmitting mode.
4	The EUT get into the test mode to provide data rate, channel, bandwidth and power level.

1.5. Configuration of Test System Details

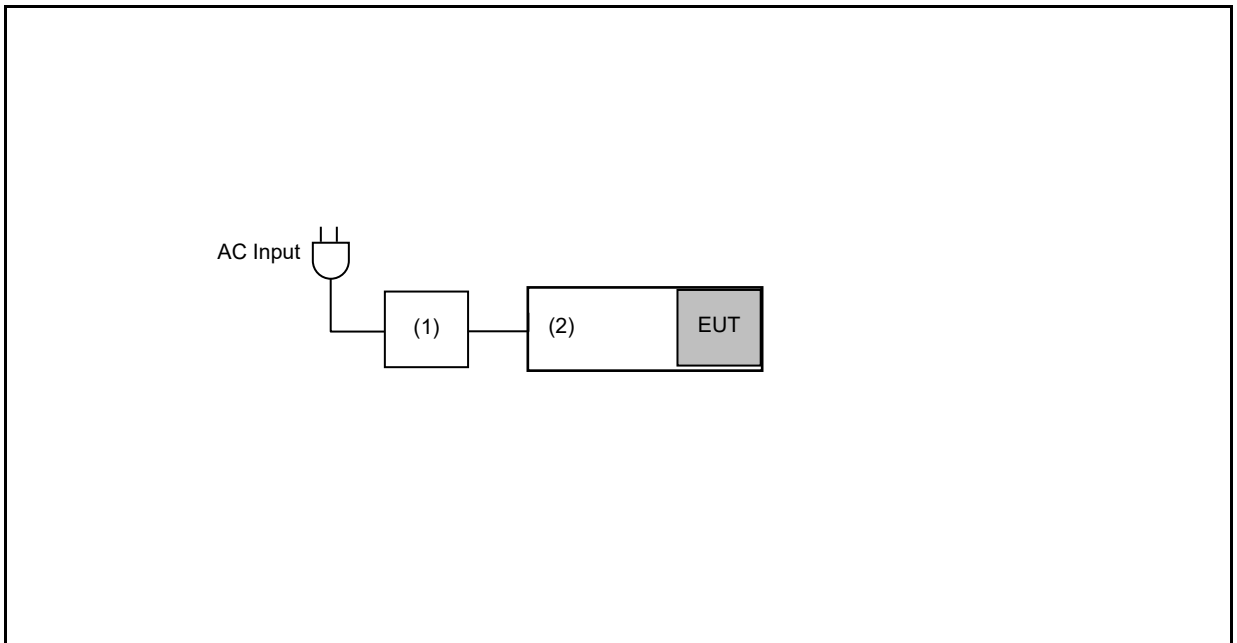

Devices Description					
	Product	Manufacturer	Model Number	Serial Number	Power Cord
(1)	Adapter	FSP	FSP065-RBBN3	---	---
(2)	Tablet	Getac	UX10G3	---	---

1.6. Test Instruments

For Radiated Emissions

Test Period: Nov. 08, 2022

Testing Engineer: Hung Chou

Test Site		96603-BD				
Radiation test sites		Semi Anechoic Room				
Use	Equipment	Manufacturer	Model Number	Serial Number	Cal. Date	Cal. Period
<input checked="" type="checkbox"/>	Spectrum Analyzer (10 Hz~44 GHz)	Keysight	N9020B	MY60112363	Feb. 27, 2022	1 year
<input checked="" type="checkbox"/>	Amplifier (100 kHz~1.3 GHz)	Agilent	8447D	2944A11119	Jan. 14, 2022	1 year
<input type="checkbox"/>	Amplifier (100 kHz~1.3 GHz)	Agilent	8447D	2944A10961	Jul. 07, 2022	1 year
<input type="checkbox"/>	Broadband Amplifier (100 kHz~1 GHz)	Titan	T0910E00014330 A1F	001	Jul. 21, 2022	1 year
<input checked="" type="checkbox"/>	Broadband Amplifier (1 GHz~26.5 GHz)	Titan	T0912E01263025 A1F	002	Jul. 21, 2022	1 year
<input checked="" type="checkbox"/>	Preamplifier (26.5 GHz~40 GHz)	EMCI	EMC2654045	980028	Sep. 02, 2022	1 year
<input checked="" type="checkbox"/>	Loop Antenna (9 kHz~30 MHz)	COM-POWER CORPORATION	AL-130	121014	Mar. 28, 2022	1 year
<input checked="" type="checkbox"/>	Trilog Broadband Antenna (30 kHz~1 GHz)	Schwarzbeck Mess-Elektronik	VULB9168	01146	Jul. 22, 2022	1 year
<input type="checkbox"/>	Trilog Broadband Antenna (30 kHz~1 GHz)	Schwarzbeck Mess-Elektronik	VULB9168	416	Nov. 17, 2021	1 year
<input checked="" type="checkbox"/>	Broadband Horn Antenna (1 GHz~18 GHz)	Schwarzbeck Mess-Elektronik	9120D	02207	Jul. 13, 2022	1 year
<input type="checkbox"/>	Broadband Horn Antenna (1 GHz~18 GHz)	Schwarzbeck Mess-Elektronik	9120D	9120D-550	Aug. 25, 2022	1 year
<input checked="" type="checkbox"/>	Broadband Horn Antenna (18 GHz~40 GHz)	Schwarzbeck Mess-Elektronik	9170	9170-320	Aug. 25, 2022	1 year
<input checked="" type="checkbox"/>	Coaxial Cable	Titan	T0710AT327A10A 100	J11005	Aug. 04, 2022	1 year
<input checked="" type="checkbox"/>	Coaxial Cable	Titan	T0710AT327A10A 900	J11004	Aug. 04, 2022	1 year
<input checked="" type="checkbox"/>	Coaxial Cable	Titan	CFD400NL-LW	001	Aug. 04, 2022	1 year
<input checked="" type="checkbox"/>	Universal Radio Communication Tester	R&S	CMU200	112387	Feb. 27, 2022	1 year
<input checked="" type="checkbox"/>	Software	EZ EMC	1.1.4.4	N/A	N.C.R.	---

Note: N.C.R. = No Calibration Request.

1.7. Test Site Environment

Items	Required (IEC 68-1)	Actual
Temperature (°C)	15-35	20-30
Humidity (%RH)	25-75	45-75

1.8. Measurement Uncertainty

Parameter	Uncertainty
Radiated Emission	6.3 dB

1.9. Summary of Test Result

FCC Rule	Description	Result
§2.1046	Conducted Output Average Power	N/A (Note1)
§22.913 §24.232 §27.50 §90.635	Equivalent Isotropic Radiated Power / Equivalent Radiated Power	N/A (Note1)
§2.1055 §22.355 §24.235 §27.54	Frequency Stability	N/A (Note1)
§2.1049	Emission Bandwidth & Occupied Bandwidth	N/A (Note1)
§24.232 §27.50	Peak to average ratio	N/A (Note1)
§2.1051 §22.917 §24.238 §27.53	Band Edge	N/A (Note1)
§2.1051 §22.917 §24.238 §27.53	Conducted Spurious Emissions	N/A (Note1)
§2.1053 §22.917 §24.238 §27.53 §90.691	Radiated Spurious Emissions	Pass (Note2)

Note 1: Class II permissive change. No need for verification.

Note 2: Only verify the Simultaneous Transmission.

Decision Rule

- Uncertainty is not included.
- Uncertainty is included.

2 Measurement Procedure

2.1. Radiated Emission Test

■ Limit

The power of any emission outside a licensee's frequency block shall be attenuated below the transmitter power (P) by at least $43 + 10 \log_{10}(P)$ dB. The limit of emission equal to -13 dBm

■ Setup

Below 1 GHz

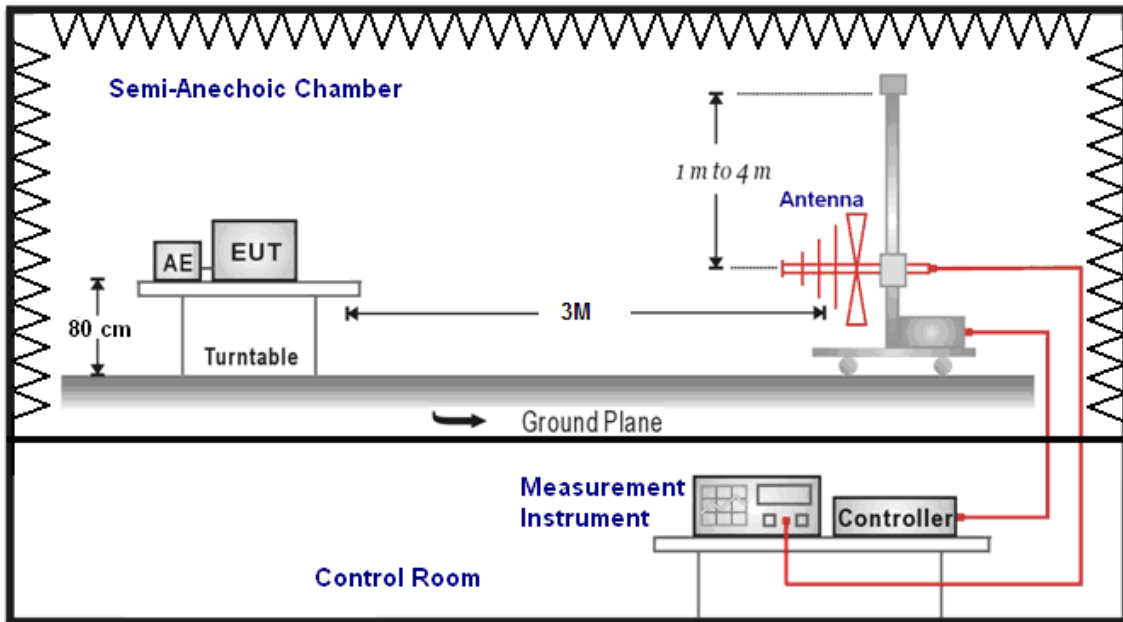

Above 1 GHz

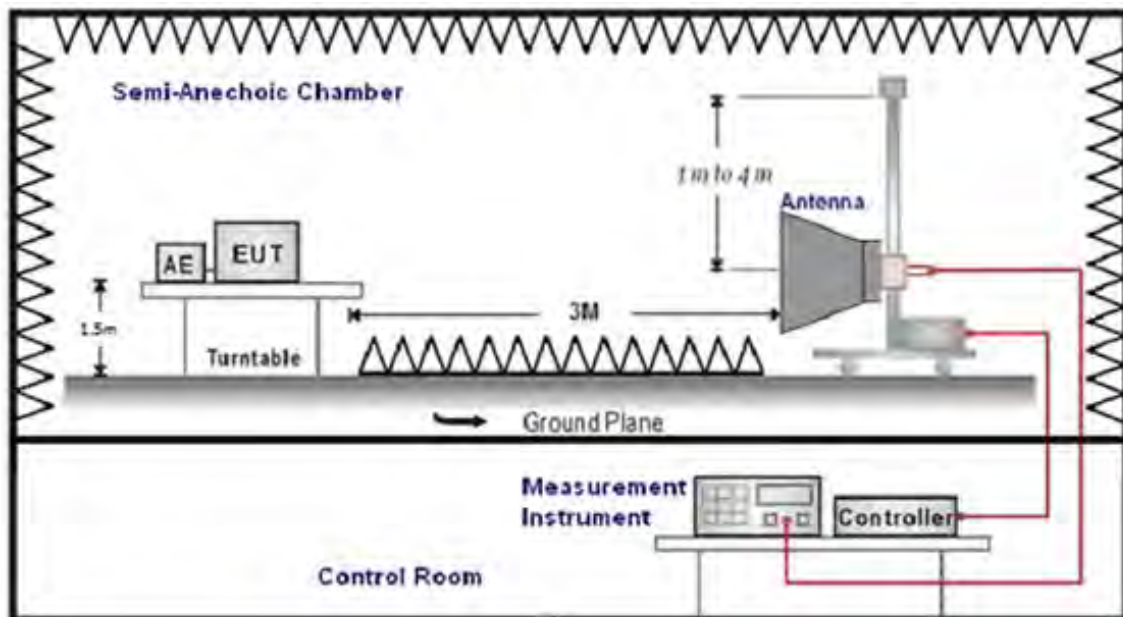

For Substituted Method Test Set-UP

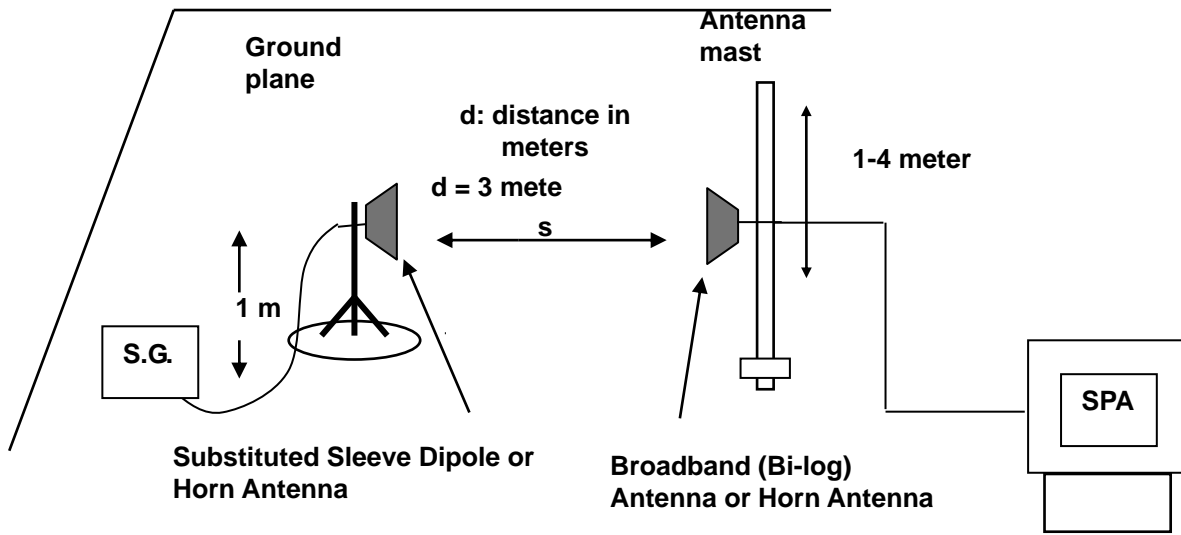

■ Test Procedure

- a. The EUT was set up for the maximum power with WWAN link data modulation. The power was measured with Spectrum Analyzer. All measurements were done at 3 channels (low, middle and high operational frequency range).
- b. Radiation Emission measurement. In the semi-anechoic chamber, EUT placed on the 0.8 m (1.5 m for above 1 GHz) height of Turn Table, rotated the table around 360 degrees to search the maximum radiation power and receiver antenna shall be rotated vertical and horizontal polarization and moved height from 1 m to 4 m to find the maximum polar radiated power. The “Read Value” is the spectrum reading the maximum power value.
- c. The substitution antenna (Note:1 & 2) is substituted for EUT at the same position and signals generator export the CW signal to the substitution antenna via a TX cable. Rotated the Turn Table and moved receiving antenna to find the maximum radiation power. Adjust output power level of S.G to get a Value of spectrum reading equal to “Read Value” of step a. Record the power level of S.G.
- d. E.I.R.P. = Output power level of S.G - TX cable loss + Antenna gain of substitution horn
- e. E.R.P. = E.I.R.P- 2.15 dB
- f. Measurement range 9 kHz - 10 th Harmonic

Note: 1. Below 1 GHz Substituted Method Test : Sleeve dipole antenna to Bi-Log Antenna

2. Above 1 GHz Substituted Method Test : Horn antenna to Horn Antenna

3 Test Results

3.1. Radiated Emission

Standard:	Part 22H/24E/27/90/96	Test Site:	966 Chamber
Polarization:	Horizontal		
Test Mode:	LTE(B41_CA 20+20)+BT+2.4G		
Remark:			

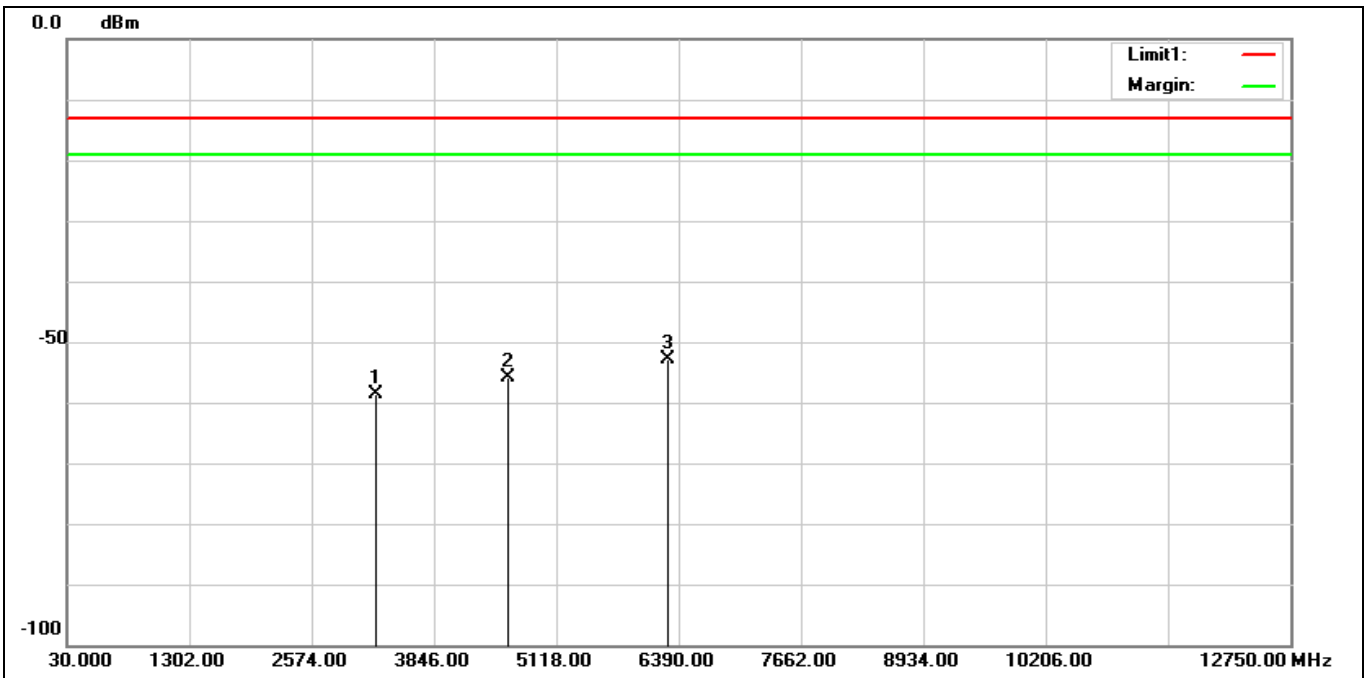

No.	Frequency (MHz)	Reading (dBm)	Correction (dB)	Result (dBm)	Limit (dBm)	Margin (dB)	Remark
1	3244.250	-66.16	7.47	-58.69	-13.00	-45.69	peak
2	4619.000	-67.10	11.31	-55.79	-13.00	-42.79	peak
3*	6264.000	-68.92	16.09	-52.83	-13.00	-39.83	peak

Standard:	Part 22H/24E/27/90/96	Test Site:	966 Chamber
Polarization:	Vertical		
Test Mode:	LTE(B41_CA 20+20)+BT+2.4G		
Remark:			

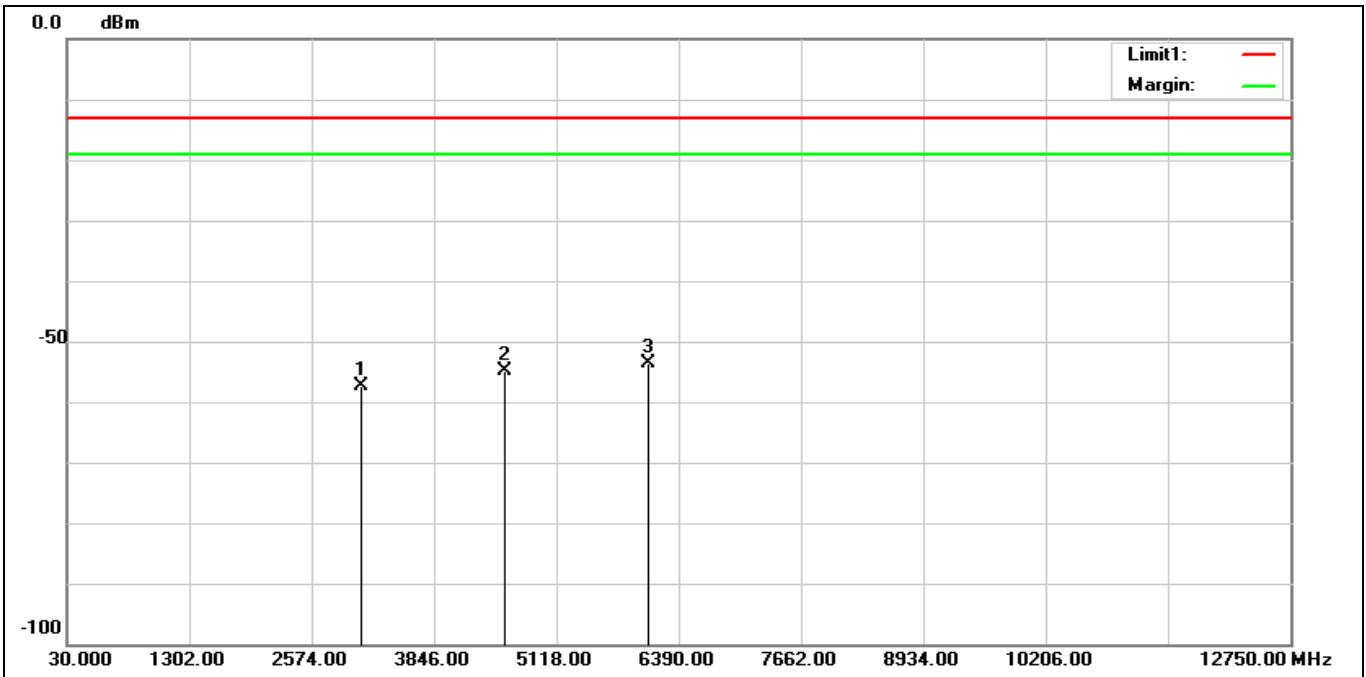

No.	Frequency (MHz)	Reading (dBm)	Correction (dB)	Result (dBm)	Limit (dBm)	Margin (dB)	Remark
1	3091.500	-64.60	7.32	-57.28	-13.00	-44.28	peak
2	4572.000	-66.01	11.15	-54.86	-13.00	-41.86	peak
3*	6064.250	-69.09	15.35	-53.74	-13.00	-40.74	peak

Standard:	Part 22H/24E/27/90/96	Test Site:	966 Chamber
Polarization:	Horizontal		
Test Mode:	LTE(B41_CA 20+20)+BT+5G		
Remark:			

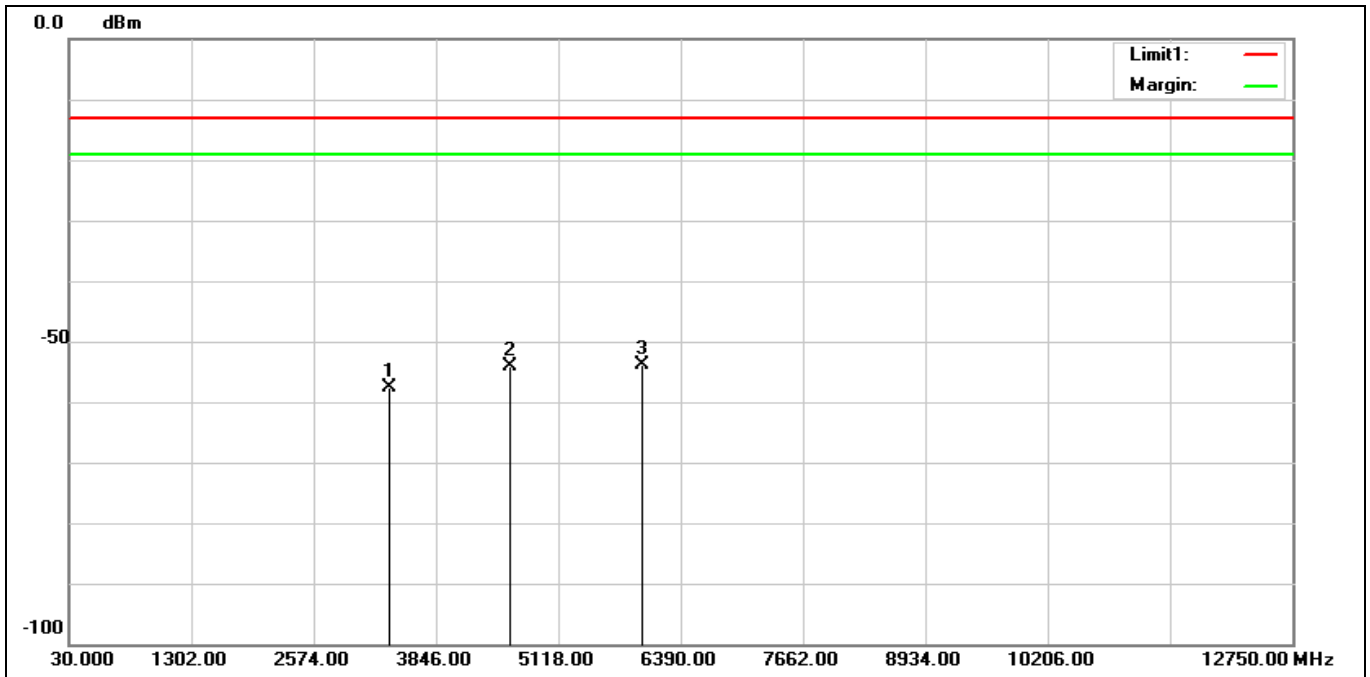

No.	Frequency (MHz)	Reading (dBm)	Correction (dB)	Result (dBm)	Limit (dBm)	Margin (dB)	Remark
1	3361.750	-65.11	7.58	-57.53	-13.00	-44.53	peak
2	4607.250	-65.49	11.26	-54.23	-13.00	-41.23	peak
3*	5982.000	-69.00	15.06	-53.94	-13.00	-40.94	peak

Standard:	Part 22H/24E/27/90/96	Test Site:	966 Chamber
Polarization:	Vertical		
Test Mode:	LTE(B41_CA 20+20)+BT+5G		
Remark:			

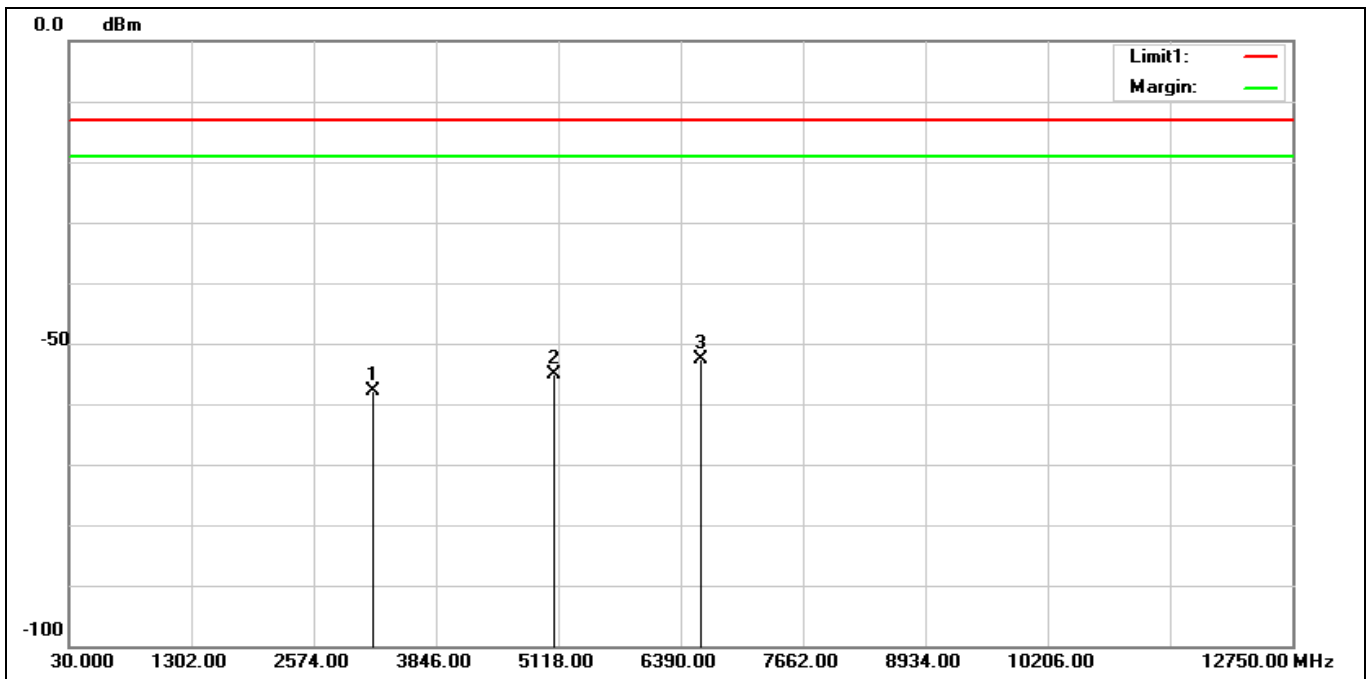

No.	Frequency (MHz)	Reading (dBm)	Correction (dB)	Result (dBm)	Limit (dBm)	Margin (dB)	Remark
1	3173.750	-65.39	7.40	-57.99	-13.00	-44.99	peak
2	5077.250	-67.91	12.72	-55.19	-13.00	-42.19	peak
3*	6581.250	-69.79	17.19	-52.60	-13.00	-39.60	peak

Standard:	Part 22H/24E/27/90/96	Test Site:	966 Chamber
Polarization:	Horizontal		
Test Mode:	LTE(B41_CA 20+20)+BT+WIFI 6E		
Remark:			

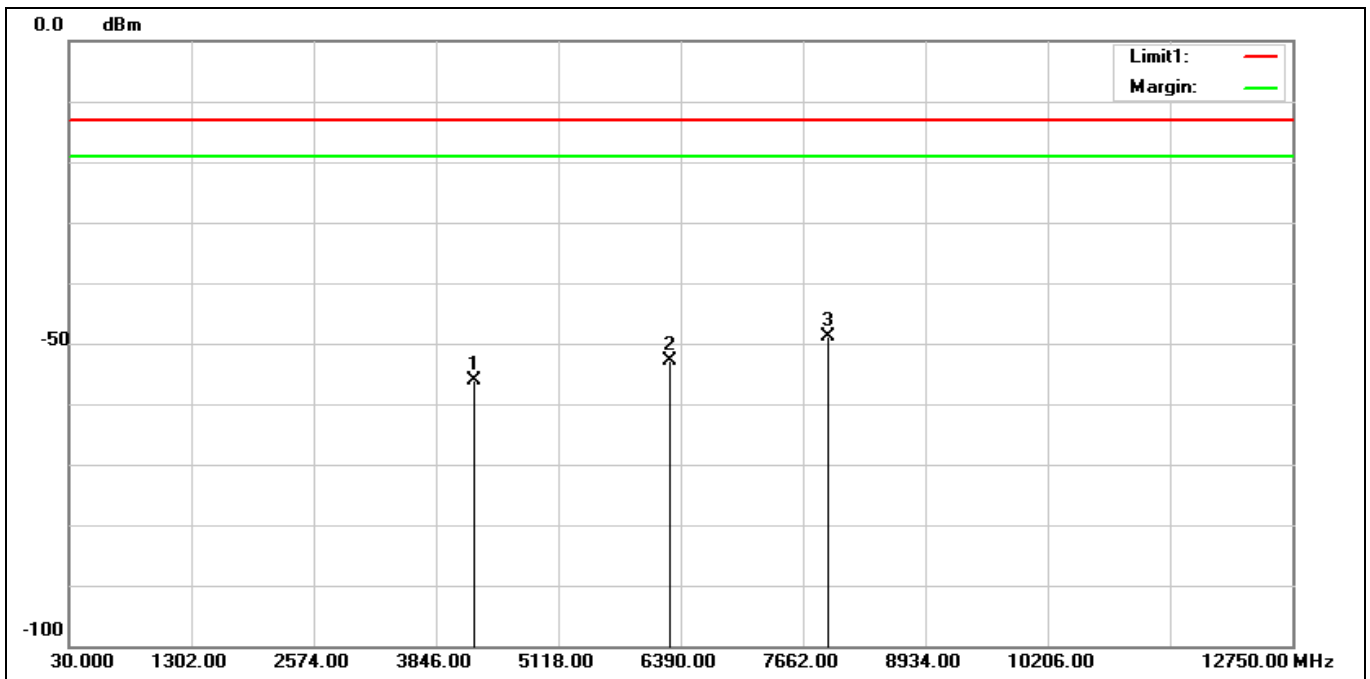

No.	Frequency (MHz)	Reading (dBm)	Correction (dB)	Result (dBm)	Limit (dBm)	Margin (dB)	Remark
1	4231.250	-66.25	10.16	-56.09	-13.00	-43.09	peak
2	6264.000	-68.92	16.09	-52.83	-13.00	-39.83	peak
3*	7909.000	-69.91	21.00	-48.91	-13.00	-35.91	peak

Standard:	Part 22H/24E/27/90/96	Test Site:	966 Chamber
Polarization:	Vertical		
Test Mode:	LTE(B41_CA 20+20)+BT+WIFI 6E		
Remark:			

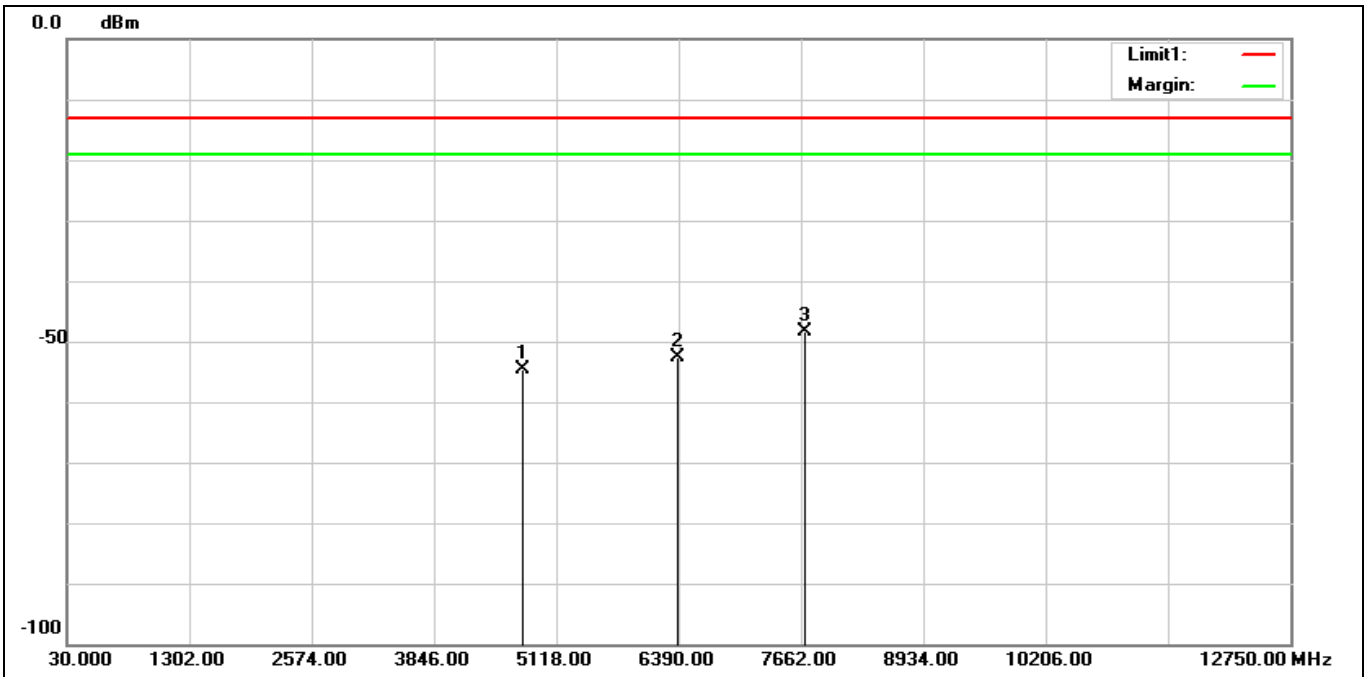

No.	Frequency (MHz)	Reading (dBm)	Correction (dB)	Result (dBm)	Limit (dBm)	Margin (dB)	Remark
1	4771.750	-66.54	11.80	-54.74	-13.00	-41.74	peak
2	6369.750	-68.98	16.48	-52.50	-13.00	-39.50	peak
3*	7697.500	-69.08	20.62	-48.46	-13.00	-35.46	peak

--- END---