

FCC Test Report

(PART 27)

Report No.: RFBASM-WTW-P20120917-6

FCC ID: QYLEM7511K

Test Model: EM7511

Received Date: Dec. 29, 2020

Test Date: Jan. 15 ~ Feb. 20, 2021

Issued Date: Jun. 09, 2021

Applicant: Getac Technology Corporation.

Address: 5F., Building A, No. 209, Sec.1, Nangang Rd., Nangang Dist., Taipei City
11568, Taiwan, R.O.C.

Issued By: Bureau Veritas Consumer Products Services (H.K.) Ltd., Taoyuan Branch
Lin Kou Laboratories

Lab Address: No. 47-2, 14th Ling, Chia Pau Vil., Lin Kou Dist., New Taipei City, Taiwan

Test Location (1): No.19, Hwa Ya 2nd Rd., Wen Hwa Vil., Kwei Shan Dist., Taoyuan City
33383, Taiwan

Test Location (2): B2F., No.215, Sec. 3, Beixin Rd., Xindian Dist., New Taipei City 231,
Taiwan

FCC Registration / 788550 / TW0003

Designation Number: 427177 / TW0011



This report is for your exclusive use. Any copying or replication of this report to or for any other person or entity, or use of our name or trademark, is permitted only with our prior written permission. This report sets forth our findings solely with respect to the test samples identified herein. The results set forth in this report are not indicative or representative of the quality or characteristics of the lot from which a test sample was taken or any similar or identical product unless specifically and expressly noted. Our report includes all of the tests requested by you and the results thereof based upon the information that you provided to us. You have 60 days from date of issuance of this report to notify us of any material error or omission caused by our negligence, provided, however, that such notice shall be in writing and shall specifically address the issue you wish to raise. A failure to raise such issue within the prescribed time shall constitute your unqualified acceptance of the completeness of this report, the tests conducted and the correctness of the report contents. Unless specific mention, the uncertainty of measurement has been explicitly taken into account to declare the compliance or non-compliance to the specification.

Table of Contents

Release Control Record	3
1 Certificate of Conformity	4
2 Summary of Test Results.....	5
2.1 Measurement Uncertainty.....	5
2.2 Test Site and Instruments	6
3 General Information	7
3.1 General Description of EUT	7
3.2 Configuration of System under Test.....	9
3.2.1 Description of Support Units	9
3.3 Test Mode Applicability and Tested Channel Detail	10
3.4 EUT Operating Conditions	11
3.5 General Description of Applied Standards.....	11
4 Test Types and Results	12
4.1 Output Power Measurement.....	12
4.1.1 Limits of Output Power Measurement	12
4.1.2 Test Procedures.....	12
4.1.3 Test Setup.....	13
4.1.4 Test Results	14
4.2 Radiated Emission Measurement.....	22
4.2.1 Limits of Radiated Emission Measurement	22
4.2.2 Test Procedure	22
4.2.3 Deviation from Test Standard	22
4.2.4 Test Setup.....	23
4.2.5 Test Results	24
5 Pictures of Test Arrangements.....	48
Appendix – Information of the Testing Laboratories	49

Release Control Record

Issue No.	Description	Date Issued
RFBASM-WTW-P20120917-6	Original Release	Jun. 09, 2021

1 Certificate of Conformity

Product: Wireless Modules

Brand: Sierra Wireless, Inc.

Test Model: EM7511

Sample Status: Mass product

Applicant: Getac Technology Corporation.

Test Date: Jan. 15 ~ Feb. 20, 2021

Standards: FCC Part 27, Subpart C, M

The above equipment has been tested by **Bureau Veritas Consumer Products Services (H.K.) Ltd., Taoyuan Branch**, and found compliance with the requirement of the above standards. The test record, data evaluation & Equipment Under Test (EUT) configurations represented herein are true and accurate accounts of the measurements of the sample's RF characteristics under the conditions specified in this report.

Prepared by : Gina Liu, **Date:** Jun. 09, 2021
Gina Liu / Specialist

Approved by : Dylan Chiou, **Date:** Jun. 09, 2021
Dylan Chiou / Project Engineer

2 Summary of Test Results

Applied Standard: FCC Part 27 & Part 2			
FCC Clause	Test Item	Result	Remarks
2.1046 27.50(h)(2)	Equivalent Isotropic Radiated Power	Pass	Meet the requirement of limit.
2.1047	Modulation Characteristics	N/A	Refer to Note
2.1055 27.54	Frequency Stability	N/A	Refer to Note
2.1049 27.53(m)(6)	Occupied Bandwidth	N/A	Refer to Note
--	Peak to Average Ratio	N/A	Refer to Note
2.1051 27.53(m)(4)(6)	Out-of-Band Emissions Measurements	N/A	Refer to Note
2.1051 27.53(m)(4)(6)	Conducted Spurious Emissions	N/A	Refer to Note
2.1053 27.53(m)(4)(6)	Radiated Spurious Emissions	Pass	Meet the requirement of limit. Minimum passing margin is -6.01 dB at 12550.00 MHz.

Note:

1. This report is a partial report, only test item of Equivalent Isotropic Radiated Power & Radiated Emissions were performed for this report. Other testing data please refer to TTL report no.: FG791919B for module (Brand: Sierra, Model: EM7511).
2. Determining compliance based on the results of the compliance measurement, not taking into account measurement instrumentation uncertainty.

2.1 Measurement Uncertainty

Where relevant, the following measurement uncertainty levels have been estimated for tests performed on the EUT as specified in CISPR 16-4-2:

Measurement	Frequency	Expanded Uncertainty (k=2) (\pm)
Radiated Emissions up to 1 GHz	9 kHz ~ 30 MHz	3.0400 dB
	30 MHz ~ 200 MHz	2.0153 dB
	200 MHz ~ 1000 MHz	2.0224 dB
Radiated Emissions above 1 GHz	1 GHz ~ 18 GHz	1.0121 dB
	18 GHz ~ 40 GHz	1.1508 dB

2.2 Test Site and Instruments

Description & Manufacturer	Model No.	Serial No.	Date of Calibration	Due Date of Calibration
Test Receiver Agilent Technologies	N9038A	MY52260177	Aug. 24, 2020	Aug. 23, 2021
Spectrum Analyzer ROHDE & SCHWARZ	FSU43	101261	Apr. 16, 2020	Apr. 15, 2021
HORN Antenna ETS-Lindgren	3117	00143293	Nov. 22, 2020	Nov. 21, 2021
BILOG Antenna SCHWARZBECK	VULB 9168	9168-616	Nov. 09, 2020	Nov. 08, 2021
HORN Antenna SCHWARZBECK	BBHA 9170	9170-480	Nov. 22, 2020	Nov. 21, 2021
Fixed Attenuator Mini-Circuits	MDCS18N-10	MDCS18N-10-01	Apr. 14, 2020	Apr. 13, 2021
MXG Vector signal generator Agilent	N5182B	MY53050430	Nov. 25, 2020	Nov. 24, 2021
Preamplifier Agilent	310N	187226	Jun. 17, 2020	Jun. 16, 2021
Preamplifier Agilent	83017A	MY39501357	Jun. 17, 2020	Jun. 16, 2021
Preamplifier EMCI	EMC 184045	980116	Oct. 07, 2020	Oct. 06, 2021
RF signal cable ETS-LINDGREN	5D-FB	Cable-CH1-01(RFC-SMS-100-SMS-120+RFC-SMS-100-SMS-400)	Jun. 17, 2020	Jun. 16, 2021
RF signal cable ETS-LINDGREN	8D-FB	Cable-CH1-02(RFC-SMS-100-SMS-24)	Jun. 17, 2020	Jun. 17, 2021
Boresight Antenna Fixture	FBA-01	FBA-SIP01	NA	NA
Software BV ADT	E3 8.130425b	NA	NA	NA
Antenna Tower MF	NA	NA	NA	NA
Turn Table MF	NA	NA	NA	NA
Antenna Tower & Turn Table Controller MF	MF-7802	NA	NA	NA
Radio Communication Analyzer Anritsu	MT8820C	6201010284	Dec. 28, 2020	Dec. 27, 2021

- Note: 1. The calibration interval of the above test instruments is 12 months and the calibrations are traceable to NML/ROC and NIST/USA.
 2. The test was performed in HsinTien Chamber 1.
 3. The horn antenna and preamplifier (model: 83017A) are used only for the measurement of emission frequency above 1 GHz if tested.

3 General Information

3.1 General Description of EUT

Product	Wireless Modules	
Brand	Sierra Wireless, Inc.	
Test Model	EM7511	
Status of EUT	Mass product	
Power Supply Rating	19 Vdc (adapter) 11.1 Vdc (battery)	
Modulation Type	QPSK, 16QAM, 64QAM	
Frequency Range	LTE Band 7 (Channel Bandwidth: 5 MHz)	2502.5 ~ 2567.5 MHz
	LTE Band 7 (Channel Bandwidth: 10 MHz)	2505 ~ 2565 MHz
	LTE Band 7 (Channel Bandwidth: 15 MHz)	2507.5 ~ 2562.5 MHz
	LTE Band 7 (Channel Bandwidth: 20 MHz)	2510 ~ 2560 MHz
	LTE Band 41 (Channel Bandwidth: 5 MHz)	2498.5 ~ 2687.5 MHz
	LTE Band 41 (Channel Bandwidth: 10 MHz)	2501.0 ~ 2685.0 MHz
	LTE Band 41 (Channel Bandwidth: 15 MHz)	2503.5 ~ 2682.5 MHz
	LTE Band 41 (Channel Bandwidth: 20 MHz)	2506.0 ~ 2680.0 MHz
Max. EIRP Power	LTE Band 7 (Channel Bandwidth: 5 MHz)	483.17 mW
	LTE Band 7 (Channel Bandwidth: 10 MHz)	462.70 mW
	LTE Band 7 (Channel Bandwidth: 15 MHz)	483.95 mW
	LTE Band 7 (Channel Bandwidth: 20 MHz)	473.15 mW
	LTE Band 41 (Channel Bandwidth: 5 MHz)	400.04 mW
	LTE Band 41 (Channel Bandwidth: 10 MHz)	389.31 mW
	LTE Band 41 (Channel Bandwidth: 15 MHz)	403.46 mW
	LTE Band 41 (Channel Bandwidth: 20 MHz)	398.75 mW
Antenna Type	PIFA Antenna with 3.72 dBi gain	
Accessory Device	Refer to Note as below	
Data Cable Supplied	Refer to Note as below	

Note:

1. The EUT is authorized for use in specific End-product. Please refer to below for more details.

Product	Brand	Model	Description
Tablet	Getac	K120	For marketing purpose
		K120G2	
		K120Y (Y= 10 characters, Y can be 0-9, a-z, A-Z, "-", "_", or blank for marketing purpose and no impact safety related critical components and constructions)	

2. The End-product contains following accessory devices.

Product	Brand	Model	Description
Adapter	Chicony	A15-090P1A	INPUT: 100-240Vac, 1.2A max, 50-60Hz OUTPUT: 19.0Vdc, 4.74A, 90W
Battery	Getac	BP3S1P2100S-01	Rating: 11.1Vdc 2040mAh, 23Wh Typical Capacity: 2100mAh, 24Wh
Earphone	N/A	N/A	--
USB Cable	N/A	N/A	--
LCD Panel	Innolux	N125HCE-HN1	FHD
Camera	Foxlink	FN20FF-679H	FHD
	Foxlink	FN80AF-443H-2	8M
	FOXLINK	FO20FF-790H	FHD
WiFi & BT Module	Intel	AX201NGW	--
WWAN Module	Sierra	EM7511	--

3. The above Antenna information is declared by manufacturer and for more detailed features description, please refer to the manufacturer's specifications, the laboratory shall not be held responsible.
4. The above EUT information is declared by manufacturer and for more detailed features description, please refers to the manufacturer's specifications or user's manual.

3.2 Configuration of System under Test

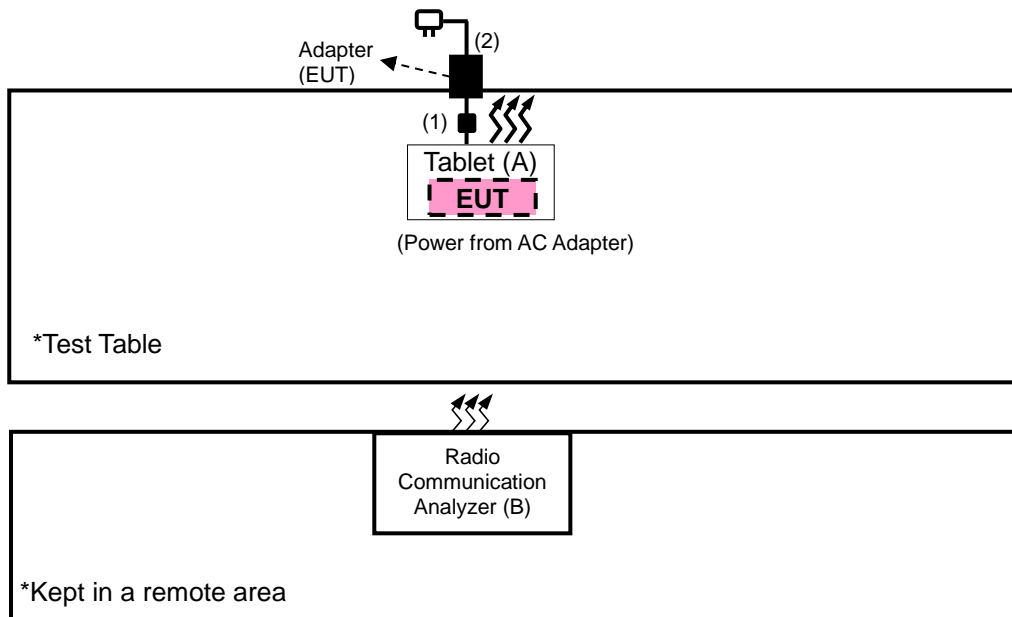

3.2.1 Description of Support Units

The EUT has been tested as an independent unit together with other necessary accessories or support units. The following support units or accessories were used to form a representative test configuration during the tests.

ID	Product	Brand	Model No.	Serial No.	FCC ID	Remarks
A.	Tablet	K120	N/A	N/A	N/A	Provided by Client
B.	Radio Communication Analyzer	Anritsu	MT8820C	6201010284	N/A	-

ID	Cable Descriptions	Qty.	Length (m)	Shielding (Yes/No)	Cores (Qty.)	Remarks
1.	DC Cable	1	1.5	N	1	Accessory of the EUT
2.	AC Power Cable	1	1.7	N	0	Accessory of the EUT

Note:

1. All power cords of the above support units are non-shielded (1.8m).
2. Item B acted as communication partner to transfer data.

3.3 Test Mode Applicability and Tested Channel Detail

Pre-Scan has been conducted to determine the worst-case mode from all possible combinations between available modulations, data rates, XYZ axis, and antenna ports.

The worst case was found when positioned as the table below. Following channel(s) was (were) selected for the final test as listed below:

Band	EIRP	Radiated Emission
LTE Band 7	Z-plane	Z-axis
LTE Band 41	X-plane	Z-axis

LTE Band 7

EUT Configure Mode	Test Item	Available Channel	Tested Channel	Channel Bandwidth	Modulation	Mode
-	EIRP	20775 to 21425	20775, 21100, 21425	5 MHz	QPSK, 16QAM, 64QAM	1 RB / 0 RB Offset
		20800 to 21400	20800, 21100, 21400	10 MHz	QPSK, 16QAM, 64QAM	1 RB / 0 RB Offset
		20825 to 21375	20825, 21100, 21375	15 MHz	QPSK, 16QAM, 64QAM	1 RB / 0 RB Offset
		20850 to 21350	20850, 21100, 21350	20 MHz	QPSK, 16QAM, 64QAM	1 RB / 0 RB Offset
-	Radiated Emission	20775 to 21425	20775, 21100, 21425	5 MHz	QPSK	1 RB / 0 RB Offset
		20850 to 21350	20850, 21100, 21350	20 MHz	QPSK	1 RB / 0 RB Offset

Note:

1. This device was tested under all bandwidths, RB configurations and modulations. The worst case was found in QPSK modulation.
2. For radiated emission above 1 GHz, according to 3GPP 36.521 Section 6.6.3.1.4, choose the lowest, 5 MHz & highest channel bandwidth for final test.
3. For radiated emissions below 1 GHz, select the worst radiated emission channel for final testing.

LTE Band 41

EUT Configure Mode	Test Item	Available Channel	Tested Channel	Channel Bandwidth	Modulation	Mode
-	EIRP	39675 to 41565	39675, 40620, 41565	5 MHz	QPSK, 16QAM, 64QAM	1 RB / 0 RB Offset
		39700 to 41540	39700, 40620, 41540	10 MHz	QPSK, 16QAM, 64QAM	1 RB / 0 RB Offset
		39725 to 41515	39725, 40620, 41515	15 MHz	QPSK, 16QAM, 64QAM	1 RB / 0 RB Offset
		39750 to 41490	39750, 40620, 41490	20 MHz	QPSK, 16QAM, 64QAM	1 RB / 0 RB Offset
-	Radiated Emission	39675 to 41565	39675, 40620, 41565	5 MHz	QPSK	1 RB / 0 RB Offset
		39750 to 41490	39750, 40620, 41490	20 MHz	QPSK	1 RB / 0 RB Offset

Note:

1. This device was tested under all bandwidths, RB configurations and modulations. The worst case was found in QPSK modulation.
2. For radiated emission above 1 GHz, according to 3GPP 36.521 Section 6.6.3.1.4, choose the lowest, 5 MHz & highest channel bandwidth for final test.
3. For radiated emissions below 1 GHz, select the worst radiated emission channel for final testing.

Test Condition:

Test Item	Environmental Conditions	Input Power	Tested By
EIRP	25 deg. C, 65 % RH	120 Vac, 60 Hz	Charles Hsiao
Radiated Emission	25 deg. C, 65 % RH	120 Vac, 60 Hz	Charles Hsiao

3.4 EUT Operating Conditions

The EUT makes a call to the communication simulator. The communication simulator station system controlled a EUT to export maximum output power under transmission mode and specific channel frequency

3.5 General Description of Applied Standards

The EUT is a RF Product. According to the specifications of the manufacturer, it must comply with the requirements of the following standards:

Test Standard:

FCC 47 CFR Part 2

FCC 47 CFR Part 27

ANSI 63.26-2015

Note: All test items have been performed and recorded as per the above standards.

References Test Guidance:

KDB 971168 D01 Power Meas License Digital Systems v03r01

ANSI/TIA/EIA-603-E 2016

Note: All test items have been performed as a reference to the above KDB test guidance.

4 Test Types and Results

4.1 Output Power Measurement

4.1.1 Limits of Output Power Measurement

The radiated peak output power shall be according to the specific rule Part 27.50(h)(2) that “Mobile stations are limited to 2.0 watts EIRP. All user stations are limited to 2 watts transmitter output power” and 27.50(i) specific that “Peak transmit power must be measure over any interval of continuous transmission using instrumentation calibration in terms of rms-equivalent voltage.”

4.1.2 Test Procedures

EIRP Measurement:

- a. All measurements were done at low, middle and high operational frequency range. RBW and VBW is 10 MHz for LTE mode.
- b. Substitution method is used for E.I.R.P measurement. In the semi-anechoic chamber, EUT placed on the 0.8 m (below or equal 1 GHz) and/or 1.5 m (above 1 GHz) height of Turn Table, rotated the table around 360 degrees to search the maximum radiation power and receiver antenna shall be rotated vertical and horizontal polarization and moved height from 1 m to 4 m to find the maximum polar radiated power. The “Read Value” is the spectrum reading the maximum power value.
- c. The substitution horn antenna is substituted for EUT at the same position and signals generator export the CW signal to the substitution antenna via a tx cable. Rotated the Turn Table and moved receiving antenna to find the maximum radiation power. Adjust output power level of S.G to get a Value of spectrum reading equal to “Read Value“ of step b. Record the power level of S.G.
- d. $EIRP = \text{Output power level of S.G} - \text{TX cable loss} + \text{Antenna gain of substitution horn}.$

Conducted Power Measurement:

- a. The EUT was set up for the maximum power with LTE link data modulation and link up with simulator.
- b. Set the EUT to transmit under low, middle and high channel and record the power level shown on simulator.

4.1.3 Test Setup

EIRP / ERP Measurement:

<Radiated Emission below or equal 1 GHz>

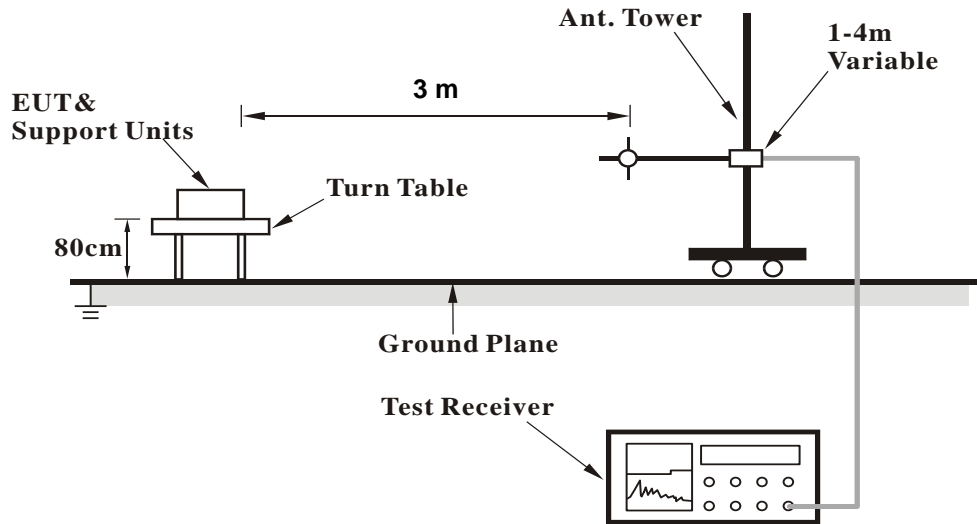

<Radiated Emission above 1 GHz>

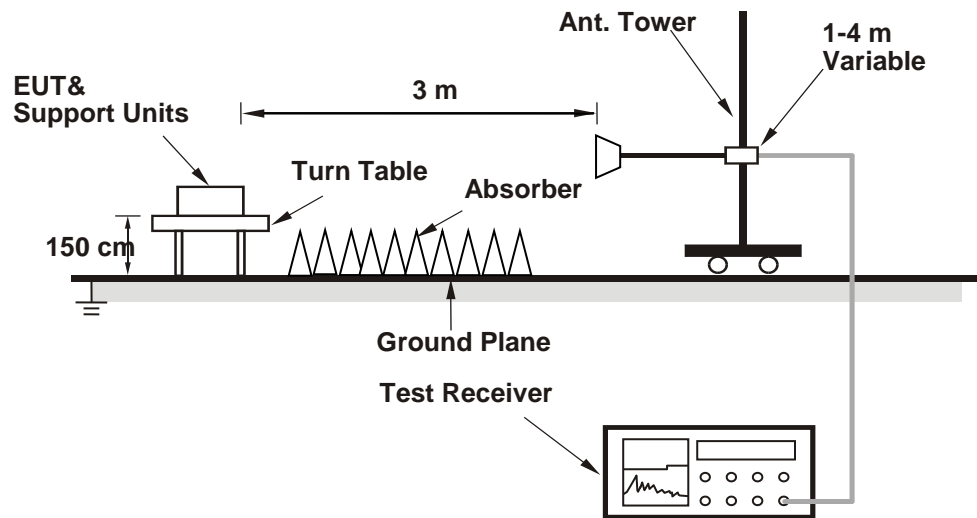

For the actual test configuration, please refer to the attached file (Test Setup Photo).

4.1.4 Test Results

EIRP Power (dBm)

LTE Band 7							
Channel Bandwidth: 5 MHz / QPSK							
Plane	Channel	Frequency (MHz)	Reading (dBm)	Correction Factor (dB)	EIRP (dBm)	EIRP (mW)	Polarization (H/V)
Z	20775	2502.5	-17.92	44.24	26.32	428.35	H
	21100	2535.0	-17.69	44.20	26.51	447.40	
	21425	2567.5	-17.96	44.80	26.84	483.17	
	20775	2502.5	-23.31	44.19	20.88	122.49	V
	21100	2535.0	-23.62	44.09	20.47	111.38	
	21425	2567.5	-23.62	44.50	20.88	122.43	
Channel Bandwidth: 5 MHz / 16QAM							
Z	20775	2502.5	-18.94	44.24	25.30	338.69	H
	21100	2535.0	-18.56	44.20	25.64	366.18	
	21425	2567.5	-19.23	44.80	25.57	360.66	
	20775	2502.5	-24.67	44.19	19.52	89.56	V
	21100	2535.0	-24.78	44.09	19.31	85.27	
	21425	2567.5	-24.93	44.50	19.57	90.55	
Channel Bandwidth: 5 MHz / 64QAM							
Z	20775	2502.5	-19.76	44.24	24.48	280.41	H
	21100	2535.0	-19.93	44.20	24.27	267.12	
	21425	2567.5	-20.03	44.80	24.77	299.99	
	20775	2502.5	-25.51	44.19	18.68	73.81	V
	21100	2535.0	-26.13	44.09	17.96	62.46	
	21425	2567.5	-25.90	44.50	18.60	72.43	

Note: EIRP (dBm) = Reading (dBm) + Correction Factor (dB)

LTE Band 7							
Channel Bandwidth: 10 MHz / QPSK							
Plane	Channel	Frequency (MHz)	Reading (dBm)	Correction Factor (dB)	EIRP (dBm)	EIRP (mW)	Polarization (H/V)
Z	20800	2505.0	-17.98	44.34	26.36	432.61	H
	21100	2535.0	-17.85	44.20	26.35	431.22	
	21400	2565.0	-18.07	44.72	26.65	462.70	
	20800	2505.0	-23.77	44.23	20.46	111.07	V
	21100	2535.0	-24.07	44.09	20.02	100.42	
	21400	2565.0	-24.02	44.41	20.39	109.29	
Channel Bandwidth: 10 MHz / 16QAM							
Z	20800	2505.0	-18.78	44.34	25.56	359.83	H
	21100	2535.0	-18.61	44.20	25.59	361.99	
	21400	2565.0	-19.10	44.72	25.62	365.01	
	20800	2505.0	-24.44	44.23	19.79	95.19	V
	21100	2535.0	-24.53	44.09	19.56	90.43	
	21400	2565.0	-24.95	44.41	19.46	88.23	
Channel Bandwidth: 10 MHz / 64QAM							
Z	20800	2505.0	-19.89	44.34	24.45	278.68	H
	21100	2535.0	-19.88	44.20	24.32	270.21	
	21400	2565.0	-20.07	44.72	24.65	291.94	
	20800	2505.0	-25.65	44.23	18.58	72.04	V
	21100	2535.0	-25.84	44.09	18.25	66.80	
	21400	2565.0	-26.48	44.41	17.93	62.03	

Note: EIRP (dBm) = Reading (dBm) + Correction Factor (dB)

LTE Band 7							
Channel Bandwidth: 15 MHz / QPSK							
Plane	Channel	Frequency (MHz)	Reading (dBm)	Correction Factor (dB)	EIRP (dBm)	EIRP (mW)	Polarization (H/V)
Z	20825	2507.5	-17.47	44.32	26.85	483.95	H
	21100	2535.0	-17.59	44.20	26.60	457.40	
	21375	2562.5	-18.39	44.85	26.46	442.38	
	20825	2507.5	-23.87	43.99	20.12	102.85	V
	21100	2535.0	-23.89	44.09	20.20	104.66	
	21375	2562.5	-24.17	44.51	20.34	108.14	
Channel Bandwidth: 15 MHz / 16QAM							
Z	20825	2507.5	-18.77	44.32	25.55	358.76	H
	21100	2535.0	-18.71	44.20	25.49	353.75	
	21375	2562.5	-19.07	44.85	25.78	378.27	
	20825	2507.5	-24.92	43.99	19.07	80.76	V
	21100	2535.0	-24.97	44.09	19.12	81.62	
	21375	2562.5	-25.19	44.51	19.32	85.51	
Channel Bandwidth: 15 MHz / 64QAM							
Z	20825	2507.5	-19.88	44.32	24.44	277.84	H
	21100	2535.0	-19.99	44.20	24.21	263.45	
	21375	2562.5	-20.40	44.85	24.45	278.48	
	20825	2507.5	-25.84	43.99	18.15	65.34	V
	21100	2535.0	-25.62	44.09	18.47	70.27	
	21375	2562.5	-26.62	44.51	17.89	61.52	

Note: EIRP (dBm) = Reading (dBm) + Correction Factor (dB)

LTE Band 7							
Channel Bandwidth: 20 MHz / QPSK							
Plane	Channel	Frequency (MHz)	Reading (dBm)	Correction Factor (dB)	EIRP (dBm)	EIRP (mW)	Polarization (H/V)
Z	20850	2510.0	-17.41	44.16	26.75	473.15	H
	21100	2535.0	-17.82	44.20	26.38	434.21	
	21350	2560.0	-18.16	44.81	26.65	462.06	
	20850	2510.0	-24.20	44.78	20.58	114.29	V
	21100	2535.0	-23.75	44.09	20.34	108.09	
	21350	2560.0	-24.25	44.72	20.47	111.43	
Channel Bandwidth: 20 MHz / 16QAM							
Z	20850	2510.0	-18.28	44.16	25.88	387.26	H
	21100	2535.0	-18.77	44.20	25.43	348.90	
	21350	2560.0	-19.04	44.81	25.77	377.31	
	20850	2510.0	-25.81	44.78	18.97	78.89	V
	21100	2535.0	-25.29	44.09	18.80	75.82	
	21350	2560.0	-25.33	44.72	19.39	86.90	
Channel Bandwidth: 20 MHz / 64QAM							
Z	20850	2510.0	-19.77	44.16	24.39	274.79	H
	21100	2535.0	-19.81	44.20	24.39	274.60	
	21350	2560.0	-20.01	44.81	24.80	301.79	
	20850	2510.0	-26.80	44.78	17.98	62.81	V
	21100	2535.0	-26.27	44.09	17.82	60.51	
	21350	2560.0	-25.99	44.72	18.73	74.64	

Note: EIRP (dBm) = Reading (dBm) + Correction Factor (dB)

LTE Band 41							
Channel Bandwidth: 5 MHz / QPSK							
Plane	Channel	Frequency (MHz)	Reading (dBm)	Correction Factor (dB)	EIRP (dBm)	EIRP (mW)	Polarization (H/V)
X	39675	2498.5	-18.37	44.24	25.87	386.19	H
	40620	2593.0	-18.72	44.20	25.48	352.94	
	41565	2687.5	-18.78	44.80	26.02	400.04	
	39675	2498.5	-21.27	44.19	22.92	195.93	V
	40620	2593.0	-21.57	44.09	22.52	178.57	
	41565	2687.5	-21.45	44.50	23.05	201.79	
Channel Bandwidth: 5 MHz / 16QAM							
X	39675	2498.5	-19.60	44.24	24.64	290.94	H
	40620	2593.0	-19.50	44.20	24.70	294.92	
	41565	2687.5	-19.86	44.80	24.94	311.96	
	39675	2498.5	-22.17	44.19	22.02	159.26	V
	40620	2593.0	-22.68	44.09	21.41	138.29	
	41565	2687.5	-22.48	44.50	22.02	159.33	
Channel Bandwidth: 5 MHz / 64QAM							
X	39675	2498.5	-20.51	44.24	23.73	235.94	H
	40620	2593.0	-20.71	44.20	23.49	223.20	
	41565	2687.5	-20.89	44.80	23.91	246.09	
	39675	2498.5	-23.18	44.19	21.01	126.21	V
	40620	2593.0	-23.69	44.09	20.40	109.60	
	41565	2687.5	-23.45	44.50	21.05	127.32	

Note: EIRP (dBm) = Reading (dBm) + Correction Factor (dB)

LTE Band 41							
Channel Bandwidth: 10 MHz / QPSK							
Plane	Channel	Frequency (MHz)	Reading (dBm)	Correction Factor (dB)	EIRP (dBm)	EIRP (mW)	Polarization (H/V)
X	39700	2501.0	-18.44	44.34	25.90	389.13	H
	40620	2593.0	-18.60	44.20	25.60	362.83	
	41540	2685.0	-18.82	44.72	25.90	389.31	
	39700	2501.0	-21.42	44.23	22.81	190.81	V
	40620	2593.0	-21.42	44.09	22.67	184.84	
	41540	2685.0	-21.38	44.41	23.03	200.72	
Channel Bandwidth: 10 MHz / 16QAM							
X	39700	2501.0	-19.64	44.34	24.70	295.19	H
	40620	2593.0	-19.54	44.20	24.66	292.21	
	41540	2685.0	-19.63	44.72	25.09	323.07	
	39700	2501.0	-22.44	44.23	21.79	150.87	V
	40620	2593.0	-22.56	44.09	21.53	142.17	
	41540	2685.0	-22.33	44.41	22.08	161.29	
Channel Bandwidth: 10 MHz / 64QAM							
X	39700	2501.0	-20.53	44.34	23.81	240.49	H
	40620	2593.0	-20.54	44.20	23.66	232.11	
	41540	2685.0	-20.79	44.72	23.93	247.34	
	39700	2501.0	-23.26	44.23	20.97	124.91	V
	40620	2593.0	-23.54	44.09	20.55	113.45	
	41540	2685.0	-23.38	44.41	21.03	126.65	

Note: EIRP (dBm) = Reading (dBm) + Correction Factor (dB)

LTE Band 41							
Channel Bandwidth: 15 MHz / QPSK							
Plane	Channel	Frequency (MHz)	Reading (dBm)	Correction Factor (dB)	EIRP (dBm)	EIRP (mW)	Polarization (H/V)
X	39725	2503.5	-18.42	44.32	25.90	388.87	H
	40620	2593.0	-18.64	44.20	25.56	359.50	
	41515	2682.5	-18.79	44.85	26.06	403.46	
	39725	2503.5	-21.04	43.99	22.95	197.33	V
	40620	2593.0	-21.39	44.09	22.70	186.12	
	41515	2682.5	-21.57	44.51	22.94	196.79	
Channel Bandwidth: 15 MHz / 16QAM							
X	39725	2503.5	-19.45	44.32	24.87	306.76	H
	40620	2593.0	-19.52	44.20	24.68	293.56	
	41515	2682.5	-19.74	44.85	25.11	324.19	
	39725	2503.5	-22.14	43.99	21.85	153.18	V
	40620	2593.0	-22.60	44.09	21.49	140.86	
	41515	2682.5	-22.57	44.51	21.94	156.31	
Channel Bandwidth: 15 MHz / 64QAM							
X	39725	2503.5	-20.44	44.32	23.88	244.23	H
	40620	2593.0	-20.58	44.20	23.62	229.99	
	41515	2682.5	-20.93	44.85	23.92	246.49	
	39725	2503.5	-22.99	43.99	21.00	125.95	V
	40620	2593.0	-23.48	44.09	20.61	115.03	
	41515	2682.5	-23.52	44.51	20.99	125.60	

Note: EIRP (dBm) = Reading (dBm) + Correction Factor (dB)

LTE Band 41							
Channel Bandwidth: 20 MHz / QPSK							
Plane	Channel	Frequency (MHz)	Reading (dBm)	Correction Factor (dB)	EIRP (dBm)	EIRP (mW)	Polarization (H/V)
X	39750	2506.0	-18.28	44.16	25.88	387.26	H
	40620	2593.0	-18.56	44.20	25.64	366.18	
	41490	2680.0	-18.80	44.81	26.01	398.75	
	39750	2506.0	-21.82	44.78	22.96	197.70	V
	40620	2593.0	-21.36	44.09	22.73	187.41	
	41490	2680.0	-21.74	44.72	22.98	198.61	
Channel Bandwidth: 20 MHz / 16QAM							
X	39750	2506.0	-19.25	44.16	24.91	309.74	H
	40620	2593.0	-19.41	44.20	24.79	301.09	
	41490	2680.0	-19.68	44.81	25.13	325.61	
	39750	2506.0	-22.73	44.78	22.05	160.32	V
	40620	2593.0	-22.45	44.09	21.64	145.81	
	41490	2680.0	-22.56	44.72	22.16	164.44	
Channel Bandwidth: 20 MHz / 64QAM							
X	39750	2506.0	-20.25	44.16	23.91	246.04	H
	40620	2593.0	-20.46	44.20	23.74	236.43	
	41490	2680.0	-20.77	44.81	24.04	253.34	
	39750	2506.0	-23.90	44.78	20.88	122.46	V
	40620	2593.0	-23.41	44.09	20.68	116.90	
	41490	2680.0	-23.67	44.72	21.05	127.35	

Note: EIRP (dBm) = Reading (dBm) + Correction Factor (dB)

4.2 Radiated Emission Measurement

4.2.1 Limits of Radiated Emission Measurement

The power of any emission outside a licensee's frequency block shall be attenuated below the transmitter power (P) by at least $55 + 10 \log (P)$ dB. The limit of emission is equal to -25 dBm.

4.2.2 Test Procedure

- a. Substitution method is used for E.I.R.P measurement. In the semi-anechoic chamber, EUT placed on the 0.8 m (below or equal 1 GHz) and/or 1.5 m (above 1 GHz) height of Turn Table, rotated the table around 360 degrees to search the maximum radiation power and receiver antenna shall be rotated vertical and horizontal polarization and moved height from 1 m to 4 m to find the maximum polar radiated power. The "Read Value" is the spectrum reading the maximum power value.
- b. EIRP = Output power level of S.G – TX cable loss + Antenna gain of substitution horn.
- c. E.R.P power can be calculated form E.I.R.P power by subtracting the gain of dipole, E.R.P power = E.I.R.P power - 2.15 dB.

NOTE:

1. The resolution bandwidth and video bandwidth of test receiver/spectrum analyzer is 1 MHz/3 MHz.
2. The emission levels were against the limit of frequency range 9 kHz ~ 30 MHz:

The amplitude of spurious emissions attenuated more than 20 dB below the permissible value is not required to be report.

4.2.3 Deviation from Test Standard

No deviation.

4.2.4 Test Setup

<Radiated Emission below or equal 1 GHz>

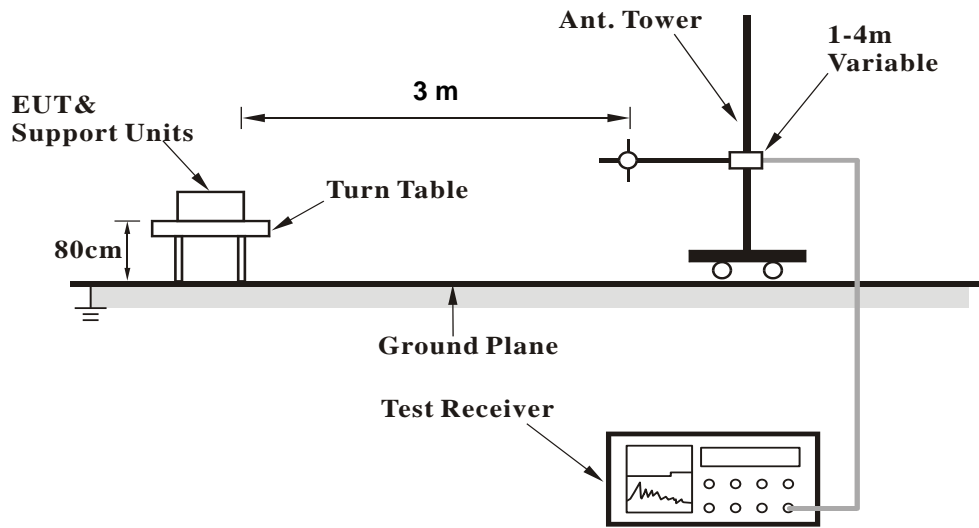

<Radiated Emission above 1 GHz>

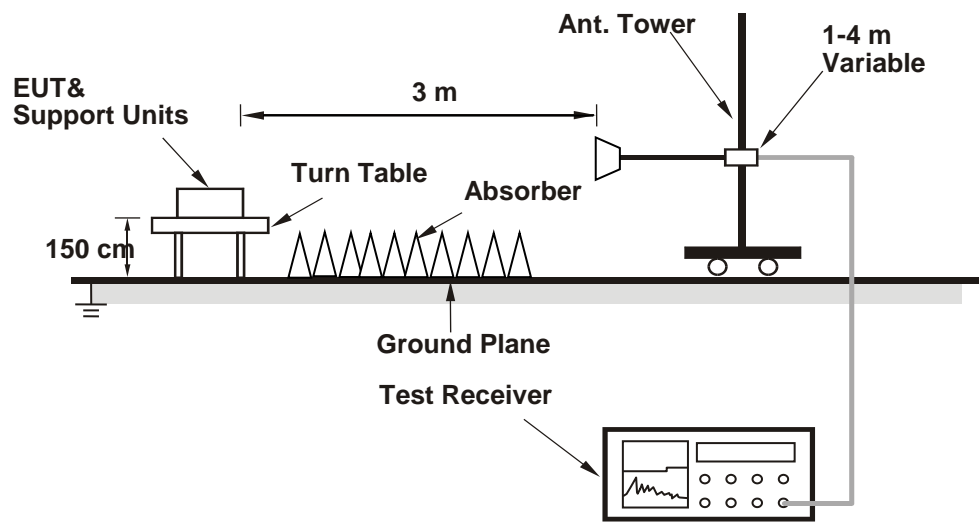

For the actual test configuration, please refer to the attached file (Test Setup Photo).

4.2.5 Test Results

LTE Band 7

Channel Bandwidth: 5 MHz / QPSK

Low Channel



Bureau Veritas Consumer Products Services Ltd., Taoyuan Branch

A D T

Data: 9

Date: 2021-01-15

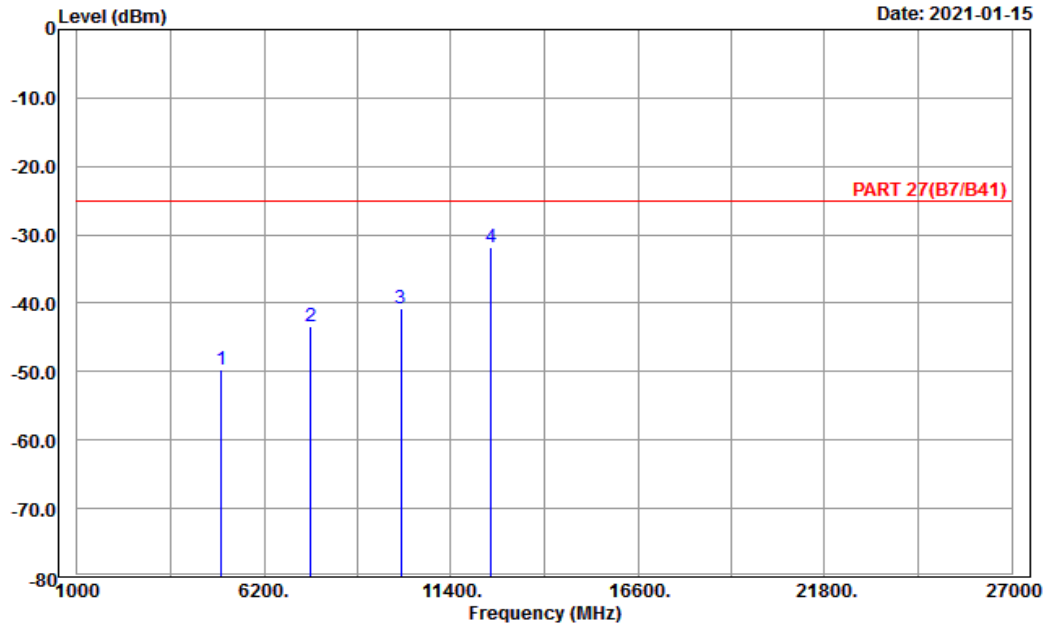

Site : 966 chamber 1
 Condition: PART 27(B7/B41) Horizontal
 Remark : LTE_Band 7_Link_L-Ch
 Tested by: Charles Hsiao

	Freq	Level	Read Level	Factor	Limit Line	Over Limit	Remark
	MHz	dBm	dBm	dB	dBm	dB	
1	5005.00	-49.63	-69.21	19.58	-25.00	-24.63	Peak
2	7507.50	-43.34	-66.02	22.68	-25.00	-18.34	Peak
3	10010.00	-40.75	-67.00	26.25	-25.00	-15.75	Peak
4 pp	12512.50	-31.73	-61.59	29.86	-25.00	-6.73	Peak



A D T

Data: 10

Date: 2021-01-15

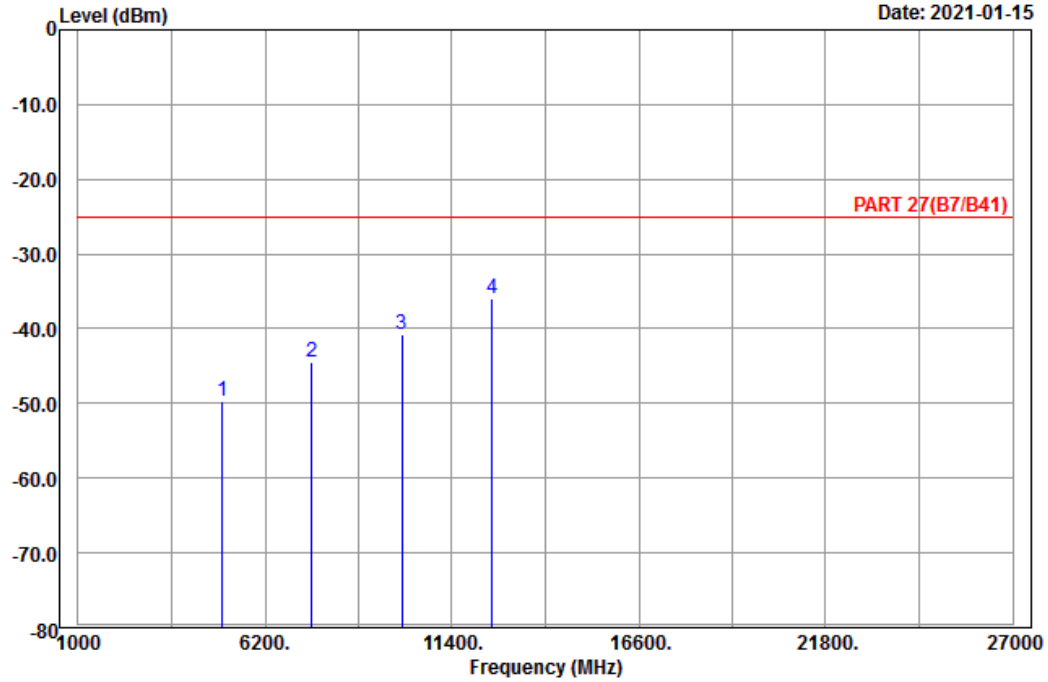

Site : 966 chamber 1
 Condition: PART 27(B7/B41) Vertical
 Remark : LTE_Band 7_Link_L-Ch
 Tested by: Charles Hsiao

	Freq	Level	Read Level	Factor	Limit Line	Over Limit	Remark
	MHz	dBm	dBm	dB	dBm	dB	
1	5005.00	-49.78	-69.36	19.58	-25.00	-24.78	Peak
2	7507.50	-44.45	-67.13	22.68	-25.00	-19.45	Peak
3	10010.00	-40.72	-66.97	26.25	-25.00	-15.72	Peak
4 pp	12512.50	-36.03	-65.89	29.86	-25.00	-11.03	Peak

Middle Channel



Bureau Veritas Consumer Products Services Ltd., Taoyuan Branch

A D T

Data: 3

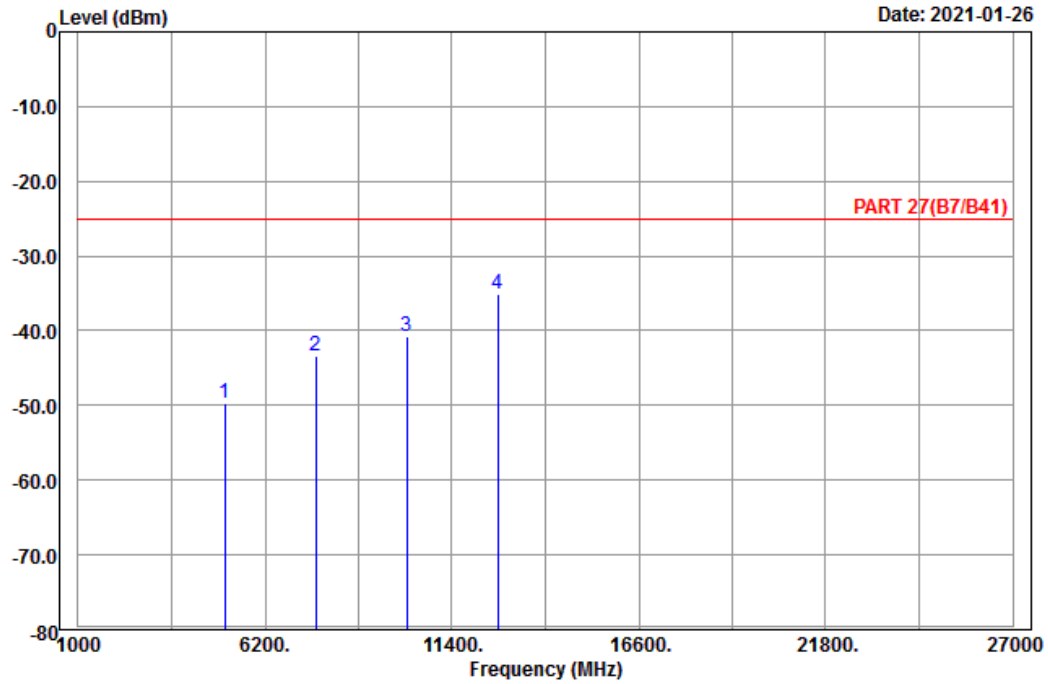

Site : 966 chamber 1
 Condition: PART 27(B7/B41) Horizontal
 Remark : LTE_Band 7_Link_M-Ch
 Tested by: Charles Hsiao

	Freq	Level	Read Level	Factor	Limit Line	Over Limit	Remark
	MHz	dBm	dBm	dB	dBm	dB	
1	5070.00	-49.62	-69.01	19.39	-25.00	-24.62	Peak
2	7605.00	-43.48	-66.47	22.99	-25.00	-18.48	Peak
3	10140.00	-40.68	-67.10	26.42	-25.00	-15.68	Peak
4 pp	12675.00	-35.13	-65.25	30.12	-25.00	-10.13	Peak



Bureau Veritas Consumer Products Services Ltd., Taoyuan Branch

A D T

Data: 4

Date: 2021-01-26

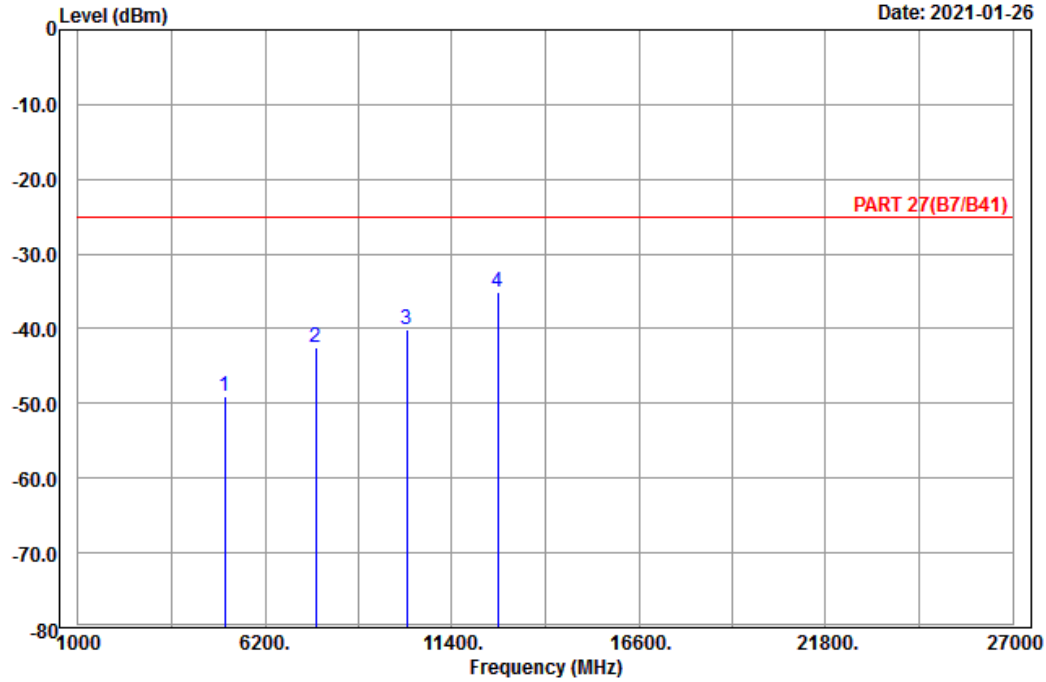

Site : 966 chamber 1
 Condition: PART 27(B7/B41) Vertical
 Remark : LTE_Band 7_Link_M-Ch
 Tested by: Charles Hsiao

	Freq	Level	Read Level	Factor	Limit Line	Over Limit	Remark
	MHz	dBm	dBm	dB	dBm	dB	
1	5070.00	-49.14	-68.53	19.39	-25.00	-24.14	Peak
2	7605.00	-42.51	-65.50	22.99	-25.00	-17.51	Peak
3	10140.00	-40.03	-66.45	26.42	-25.00	-15.03	Peak
4 pp	12675.00	-35.17	-65.29	30.12	-25.00	-10.17	Peak

High Channel



Bureau Veritas Consumer Products Services Ltd., Taoyuan Branch

A D T

Data: 9

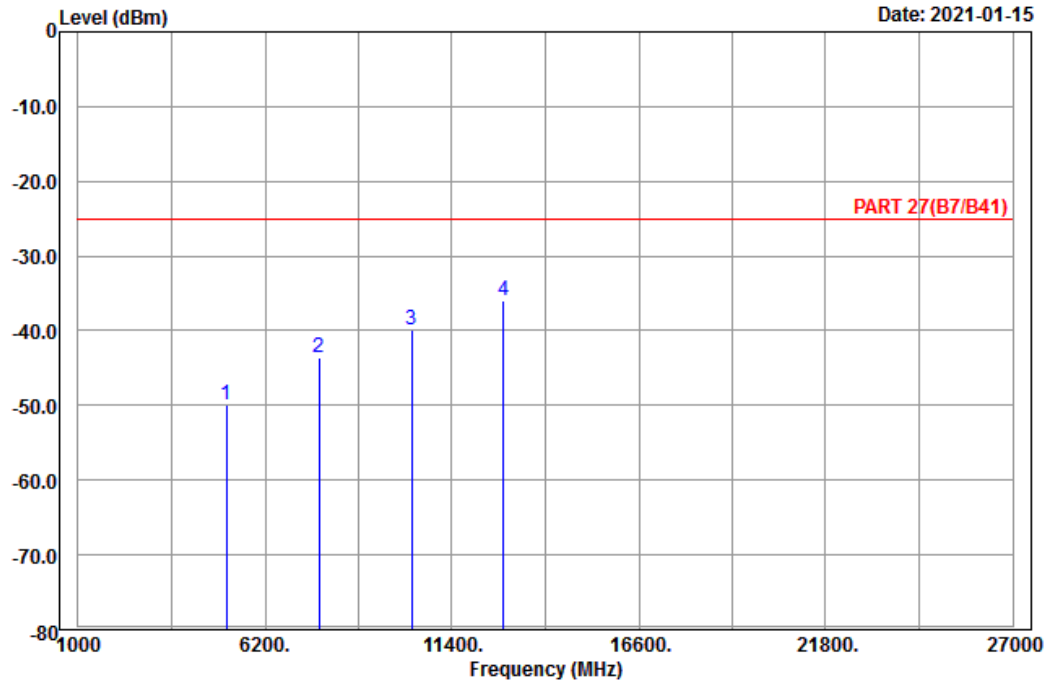

Site : 966 chamber 1
 Condition: PART 27(B7/B41) Horizontal
 Remark : LTE_Band 7_Link_H-Ch
 Tested by: Charles Hsiao

	Freq	Level	Read Level	Factor	Limit Line	Over Limit	Remark
	MHz	dBm	dBm	dB	dBm	dB	
1	5135.00	-50.00	-69.81	19.81	-25.00	-25.00	Peak
2	7702.50	-43.66	-66.82	23.16	-25.00	-18.66	Peak
3	10270.00	-39.79	-66.38	26.59	-25.00	-14.79	Peak
4 pp	12837.50	-36.06	-66.43	30.37	-25.00	-11.06	Peak



Bureau Veritas Consumer Products Services Ltd., Taoyuan Branch

A D T

Data: 10

Date: 2021-01-15

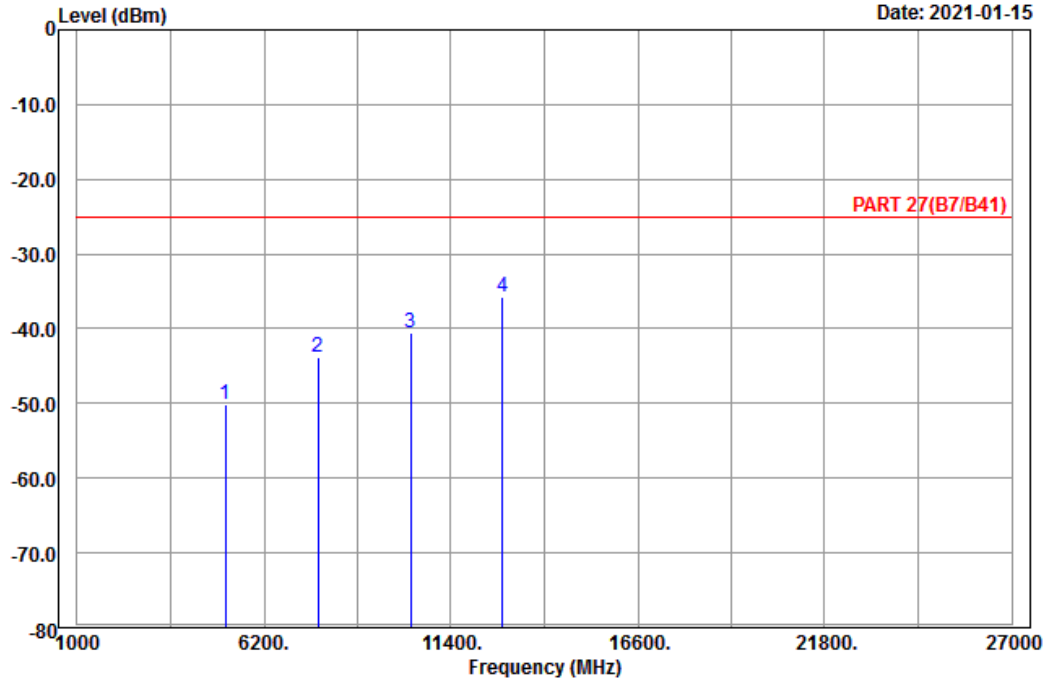

Site : 966 chamber 1
 Condition: PART 27(B7/B41) Vertical
 Remark : LTE_Band 7_Link_H-Ch
 Tested by: Charles Hsiao

	Freq	Level	Read Level	Factor	Limit Line	Over Limit	Remark
	MHz	dBm	dBm	dB	dBm	dB	
1	5135.00	-50.18	-69.99	19.81	-25.00	-25.18	Peak
2	7702.50	-43.81	-66.97	23.16	-25.00	-18.81	Peak
3	10270.00	-40.54	-67.13	26.59	-25.00	-15.54	Peak
4 pp	12837.50	-35.66	-66.03	30.37	-25.00	-10.66	Peak

Channel Bandwidth: 20 MHz / QPSK
Low Channel



Bureau Veritas Consumer Products Services Ltd., Taoyuan Branch

A D T

Data: 7

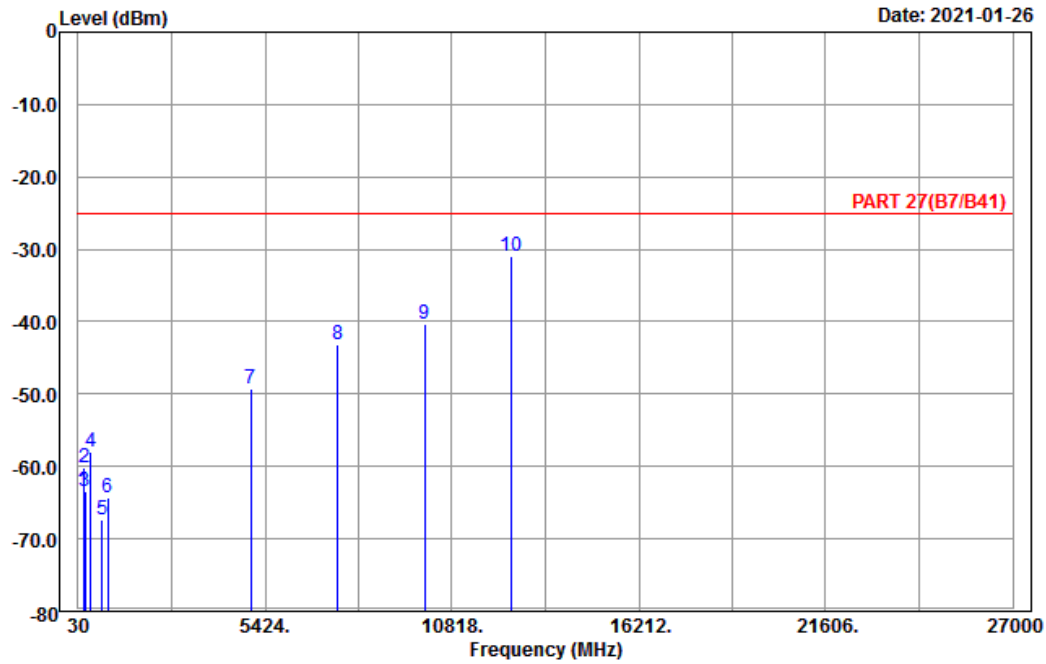

Site : 966 chamber 1
Condition: PART 27(B7/B41) Horizontal
Remark : LTE_Band 7_Link_L-Ch
Tested by: Charles Hsiao

	Freq	Level	Read Level	Factor	Limit Line	Over Limit	Remark
	MHz	dBm	dBm	dB	dBm	dB	
1	175.80	-63.46	-57.37	-6.09	-25.00	-38.46	Peak
2	207.39	-60.19	-54.11	-6.08	-25.00	-35.19	Peak
3	224.67	-63.35	-57.50	-5.85	-25.00	-38.35	Peak
4	398.00	-58.07	-55.23	-2.84	-25.00	-33.07	Peak
5	714.40	-67.33	-66.68	-0.65	-25.00	-42.33	Peak
6	878.20	-64.41	-66.66	2.25	-25.00	-39.41	Peak
7	5020.00	-49.23	-68.31	19.08	-25.00	-24.23	Peak
8	7530.00	-43.09	-65.94	22.85	-25.00	-18.09	Peak
9	10040.00	-40.24	-66.51	26.27	-25.00	-15.24	Peak
10 pp	12550.00	-31.01	-60.93	29.92	-25.00	-6.01	Peak



Bureau Veritas Consumer Products Services Ltd., Taoyuan Branch

A D T

Data: 8

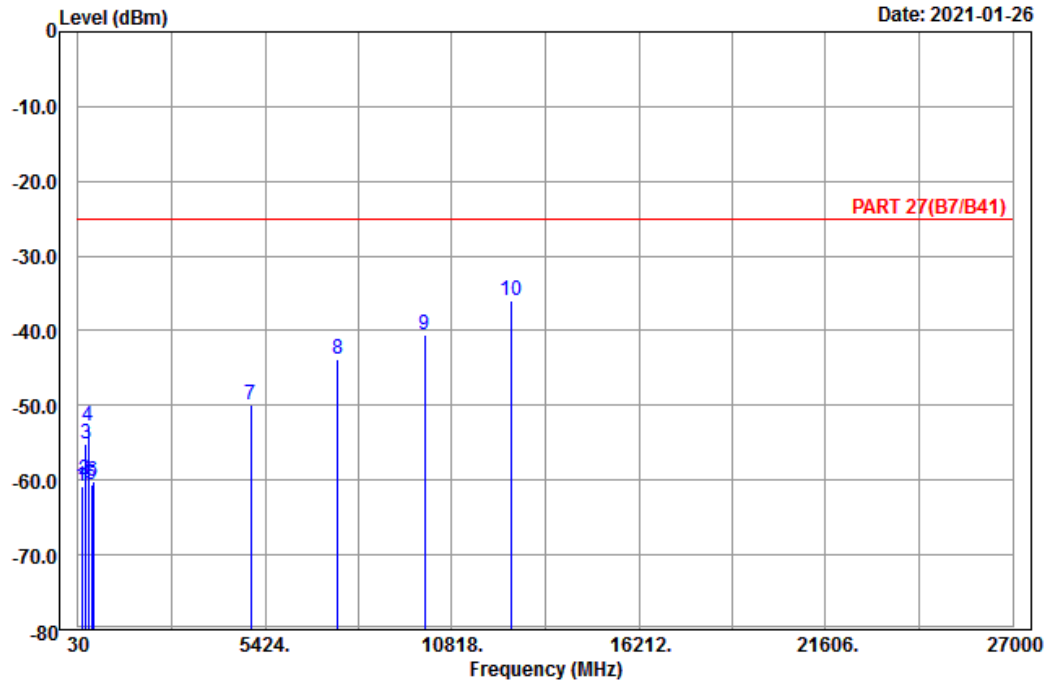

Site : 966 chamber 1
 Condition: PART 27(B7/B41) Vertical
 Remark : LTE_Band 7_Link_L-Ch
 Tested by: Charles Hsiao

	Freq	Level	Read Level	Factor	Limit Line	Over Limit	Remark
	MHz	dBm	dBm	dB	dBm	dB	
1	132.60	-60.84	-53.18	-7.66	-25.00	-35.84	Peak
2	219.81	-59.87	-53.96	-5.91	-25.00	-34.87	Peak
3	256.53	-55.25	-49.68	-5.57	-25.00	-30.25	Peak
4	316.10	-52.85	-47.08	-5.77	-25.00	-27.85	Peak
5	409.20	-60.62	-57.67	-2.95	-25.00	-35.62	Peak
6	454.00	-60.08	-56.12	-3.96	-25.00	-35.08	Peak
7	5020.00	-50.01	-69.09	19.08	-25.00	-25.01	Peak
8	7530.00	-43.80	-66.65	22.85	-25.00	-18.80	Peak
9	10040.00	-40.53	-66.80	26.27	-25.00	-15.53	Peak
10 pp	12550.00	-35.93	-65.85	29.92	-25.00	-10.93	Peak

Middle Channel



Bureau Veritas Consumer Products Services Ltd., Taoyuan Branch

A D T

Data: 9

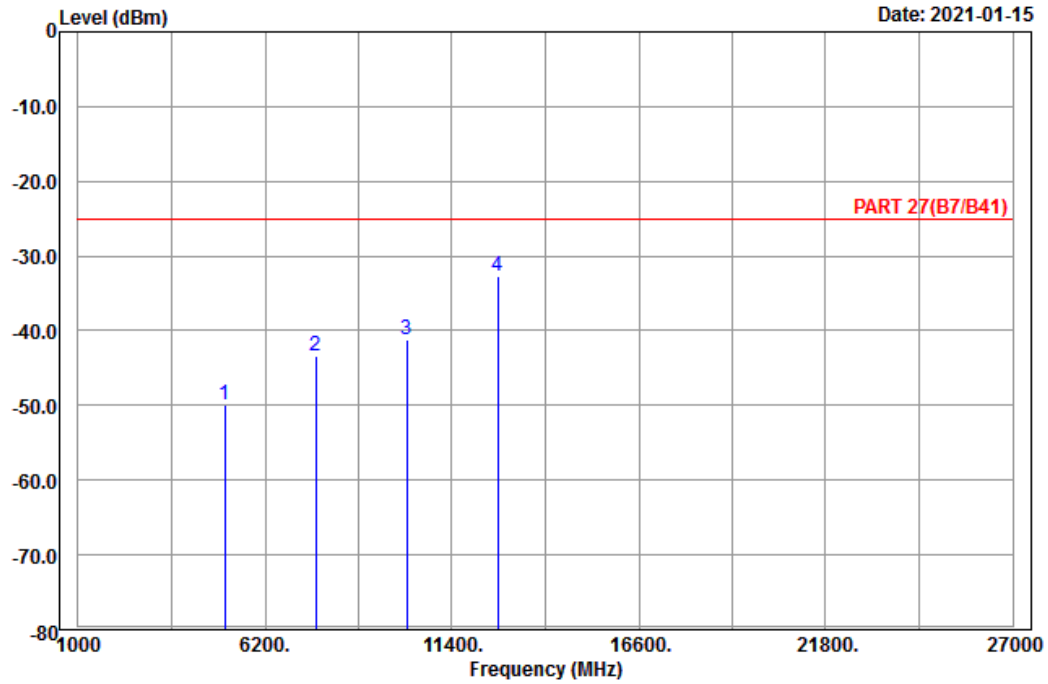

Site : 966 chamber 1
 Condition: PART 27(B7/B41) Horizontal
 Remark : LTE_Band 7_Link_M-Ch
 Tested by: Charles Hsiao

	Freq	Level	Read Level	Factor	Limit Line	Over Limit	Remark
	MHz	dBm	dBm	dB	dBm	dB	
1	5070.00	-49.91	-69.30	19.39	-25.00	-24.91	Peak
2	7605.00	-43.46	-66.45	22.99	-25.00	-18.46	Peak
3	10140.00	-41.20	-67.62	26.42	-25.00	-16.20	Peak
4 pp	12675.00	-32.72	-62.84	30.12	-25.00	-7.72	Peak



Bureau Veritas Consumer Products Services Ltd., Taoyuan Branch

A D T

Data: 10

Date: 2021-01-15

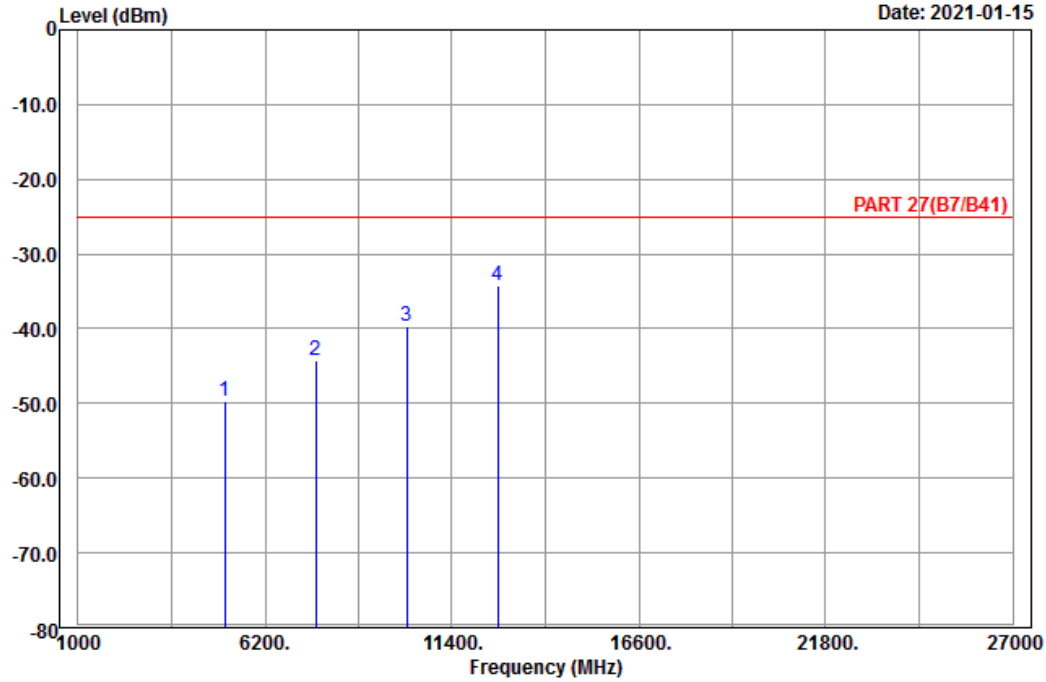

Site : 966 chamber 1
 Condition: PART 27(B7/B41) Vertical
 Remark : LTE_Band 7_Link_M-Ch
 Tested by: Charles Hsiao

	Freq	Level	Read Level	Factor	Limit Line	Over Limit	Remark
	MHz	dBm	dBm	dB	dBm	dB	
1	5070.00	-49.64	-69.03	19.39	-25.00	-24.64	Peak
2	7605.00	-44.27	-67.26	22.99	-25.00	-19.27	Peak
3	10140.00	-39.66	-66.08	26.42	-25.00	-14.66	Peak
4 pp	12675.00	-34.18	-64.30	30.12	-25.00	-9.18	Peak

High Channel



Bureau Veritas Consumer Products Services Ltd., Taoyuan Branch

A D T

Data: 3

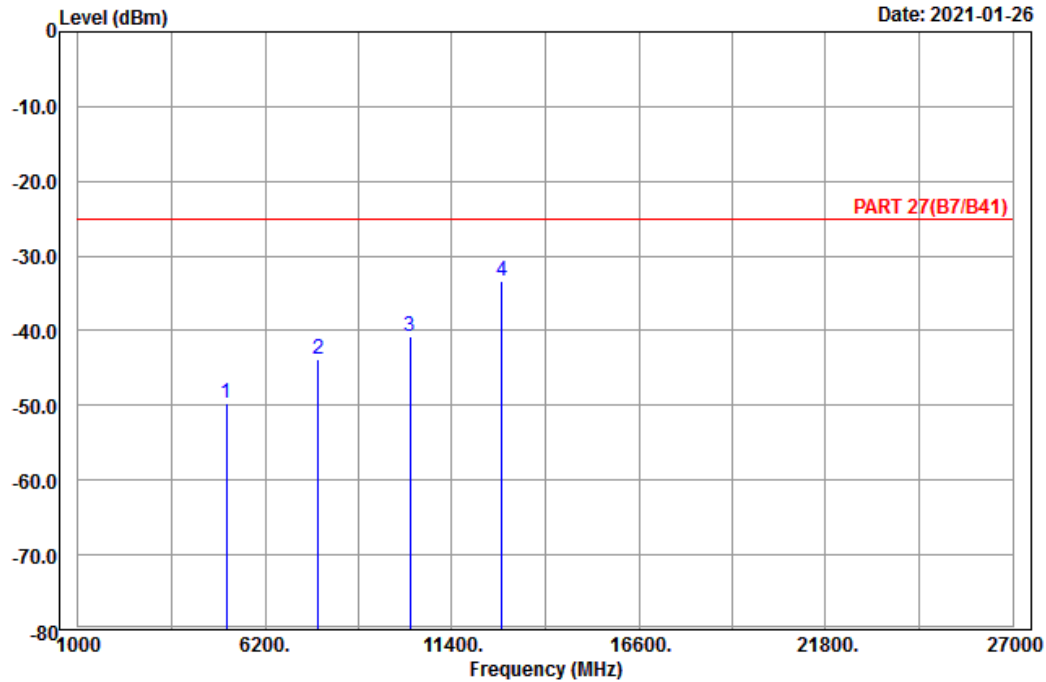

Site : 966 chamber 1
 Condition: PART 27(B7/B41) Horizontal
 Remark : LTE_Band 7_Link_H-Ch
 Tested by: Charles Hsiao

	Freq	Level	Read Level	Factor	Limit Line	Over Limit	Remark
	MHz	dBm	dBm	dB	dBm	dB	
1	5120.00	-49.73	-69.44	19.71	-25.00	-24.73	Peak
2	7680.00	-43.71	-66.83	23.12	-25.00	-18.71	Peak
3	10240.00	-40.86	-67.40	26.54	-25.00	-15.86	Peak
4 pp	12800.00	-33.37	-63.68	30.31	-25.00	-8.37	Peak



Bureau Veritas Consumer Products Services Ltd., Taoyuan Branch

A D T

Data: 4

Date: 2021-01-26

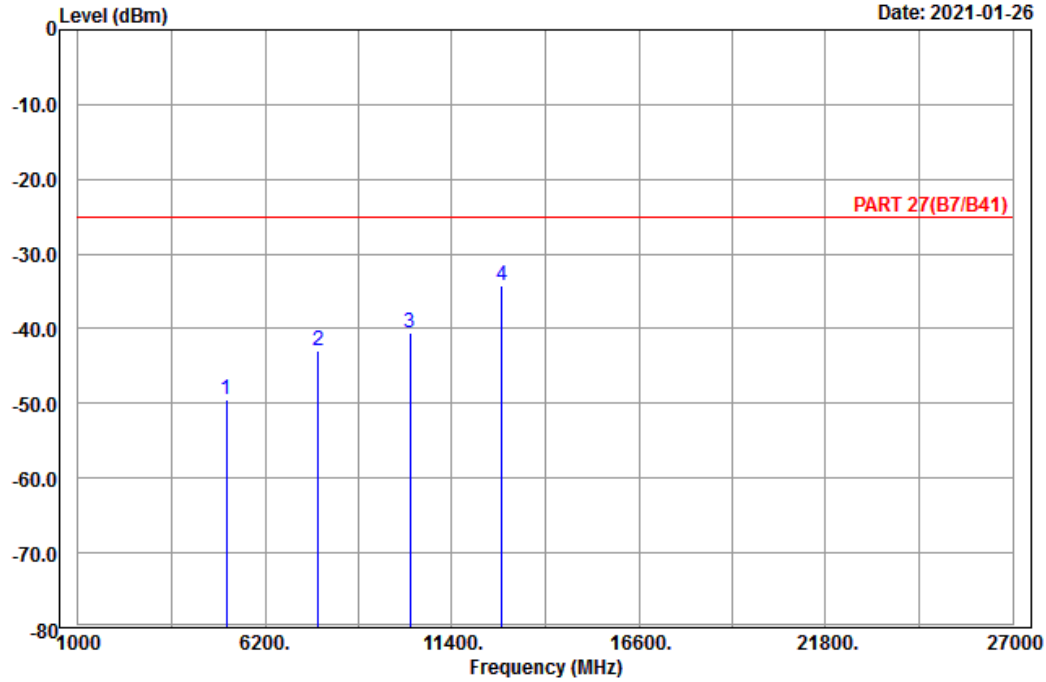

Site : 966 chamber 1
 Condition: PART 27(B7/B41) Vertical
 Remark : LTE_Band 7_Link_H-Ch
 Tested by: Charles Hsiao

	Freq	Level	Read Level	Factor	Limit Line	Over Limit	Remark
	MHz	dBm	dBm	dB	dBm	dB	
1	5120.00	-49.38	-69.09	19.71	-25.00	-24.38	Peak
2	7680.00	-42.98	-66.10	23.12	-25.00	-17.98	Peak
3	10240.00	-40.55	-67.09	26.54	-25.00	-15.55	Peak
4 pp	12800.00	-34.24	-64.55	30.31	-25.00	-9.24	Peak

LTE Band 41
 Channel Bandwidth: 5 MHz / QPSK
 Low Channel



Bureau Veritas Consumer Products Services Ltd., Taoyuan Branch

A D T

Data: 3

Date: 2021-02-20

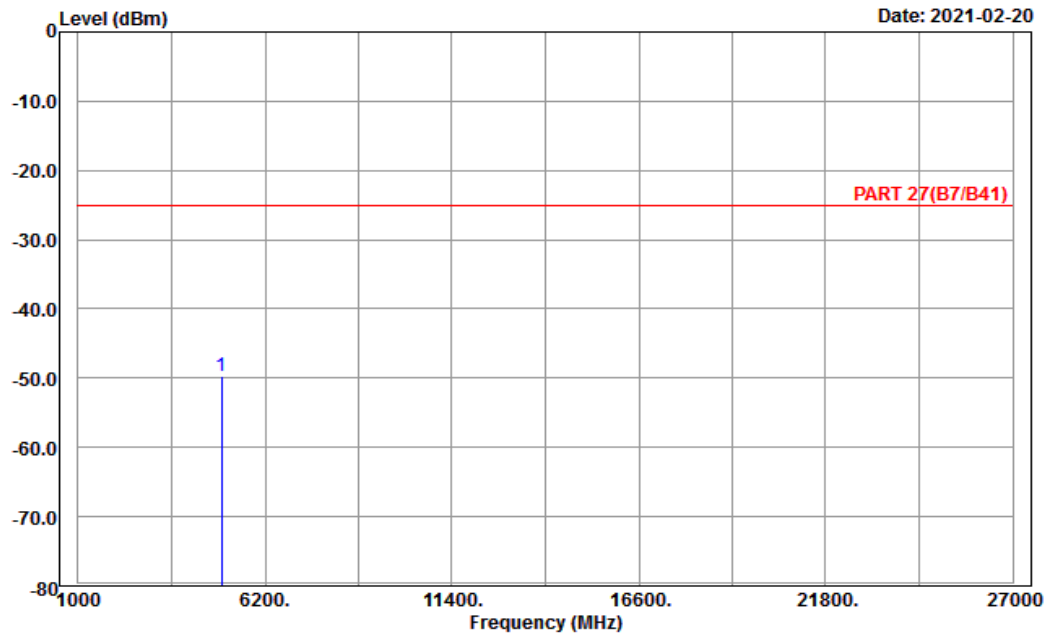

Site : 966 chamber 1
 Condition: PART 27(B7/B41) Horizontal
 Remark : LTE_Band 41_Link_L-Ch
 Tested by: Charles Hsiao

	Freq	Level	Read Level	Factor	Limit Line	Over Limit	Remark
	MHz	dBm	dBm	dB	dBm	dB	
1	pp 4997.00	-49.60	-69.18	19.58	-25.00	-24.60	Peak



Bureau Veritas Consumer Products Services Ltd., Taoyuan Branch

A D T

Data: 4

Date: 2021-02-20

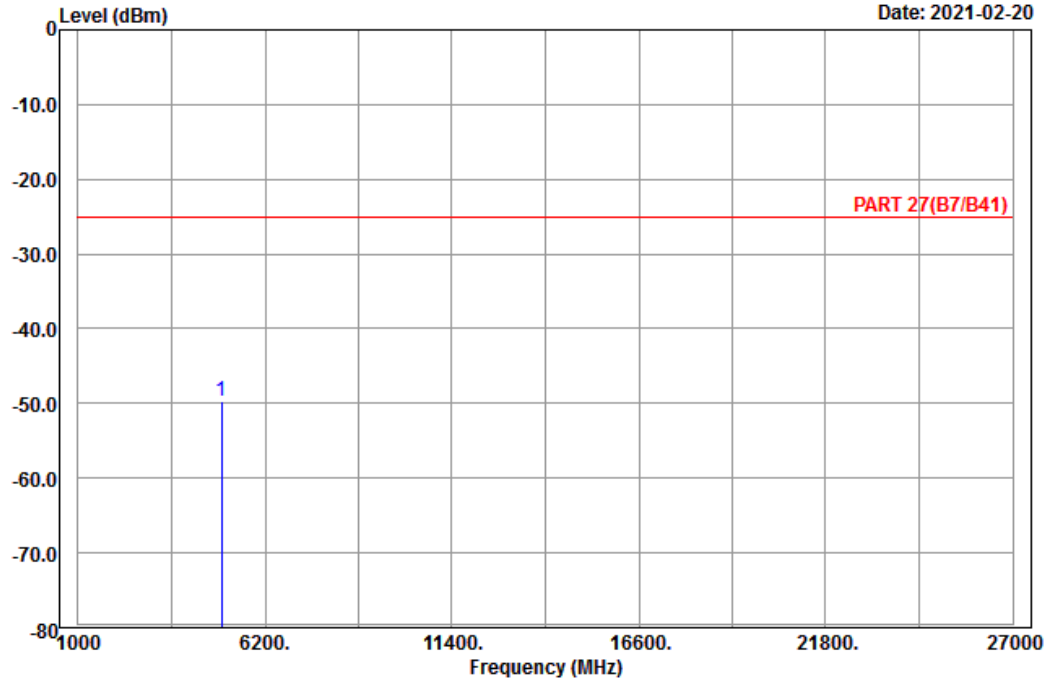

Site : 966 chamber 1
 Condition: PART 27(B7/B41) Vertical
 Remark : LTE_Band 41_Link_L-Ch
 Tested by: Charles Hsiao

Freq	Level	Read Level	Factor	Limit Line	Over Limit	Remark
MHz	dBm	dBm	dB	dBm	dB	
1 pp 4997.00	-49.78	-69.36	19.58	-25.00	-24.78	Peak

Middle Channel



Bureau Veritas Consumer Products Services Ltd., Taoyuan Branch

A D T

Data: 3

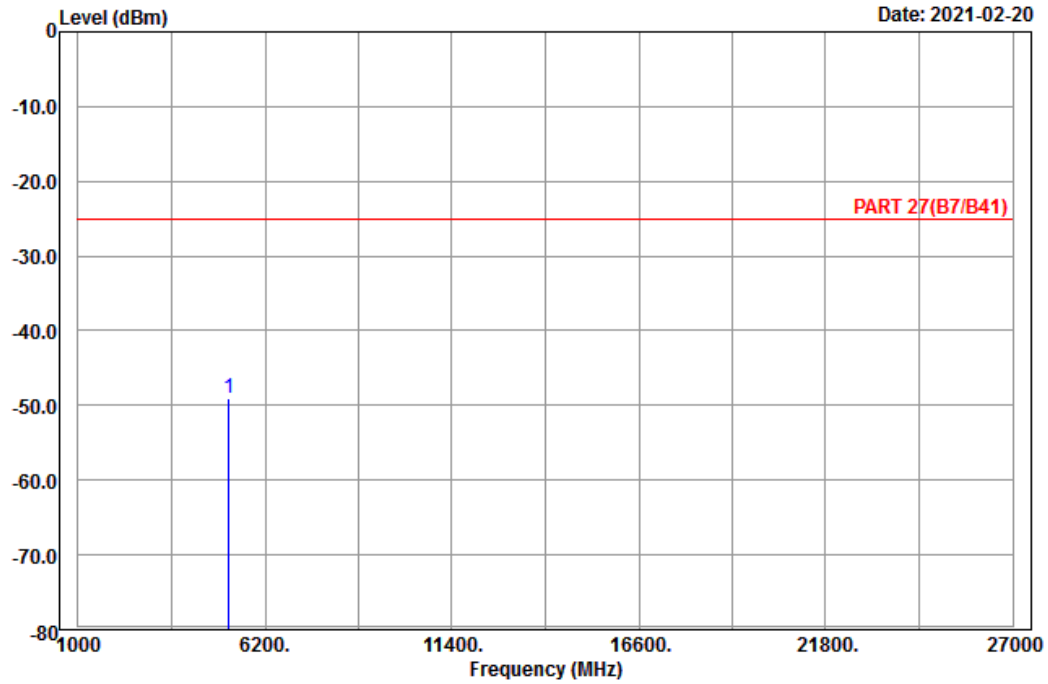

Site : 966 chamber 1
 Condition: PART 27(B7/B41) Horizontal
 Remark : LTE_Band 41_Link_M-Ch
 Tested by: Charles Hsiao

	Freq	Level	Read Level	Factor	Limit Line	Over Limit	Remark
	MHz	dBm	dBm	dB	dBm	dB	
1	pp 5186.00	-49.12	-69.24	20.12	-25.00	-24.12	Peak



Bureau Veritas Consumer Products Services Ltd., Taoyuan Branch

A D T

Data: 4

Date: 2021-02-20

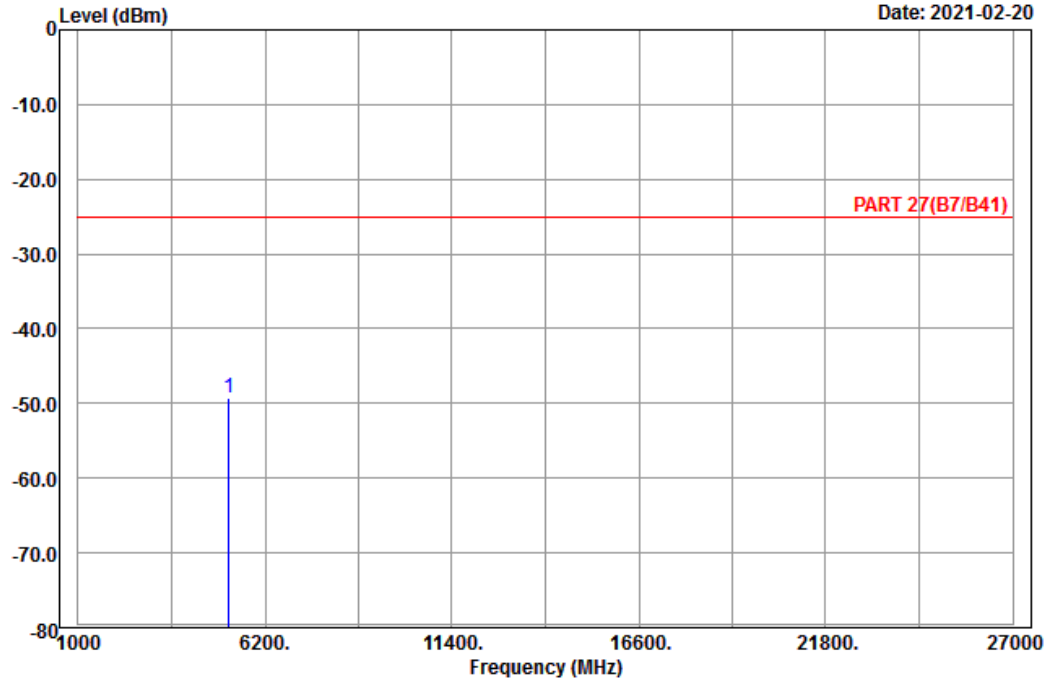

Site : 966 chamber 1
 Condition: PART 27(B7/B41) Vertical
 Remark : LTE_Band 41_Link_M-Ch
 Tested by: Charles Hsiao

Freq	Level	Read Level	Factor	Limit Line	Over Limit	Remark
MHz	dBm	dBm	dB	dBm	dB	
1 pp 5186.00	-49.24	-69.36	20.12	-25.00	-24.24	Peak

High Channel



Bureau Veritas Consumer Products Services Ltd., Taoyuan Branch

A D T

Data: 3

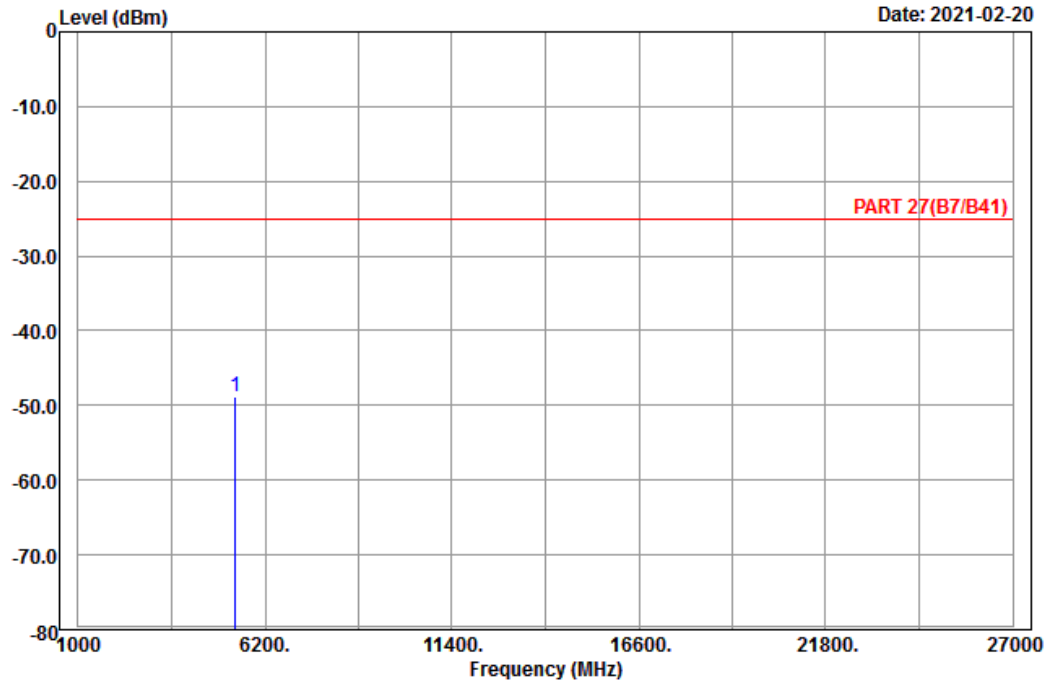

Site : 966 chamber 1
 Condition: PART 27(B7/B41) Horizontal
 Remark : LTE_Band 41_Link_H-Ch
 Tested by: Charles Hsiao

	Freq	Level	Read Level	Factor	Limit Line	Over Limit	Remark
	MHz	dBm	dBm	dB	dBm	dB	
1	pp 5375.00	-48.83	-69.15	20.32	-25.00	-23.83	Peak



Bureau Veritas Consumer Products Services Ltd., Taoyuan Branch

A D T

Data: 4

Date: 2021-02-20

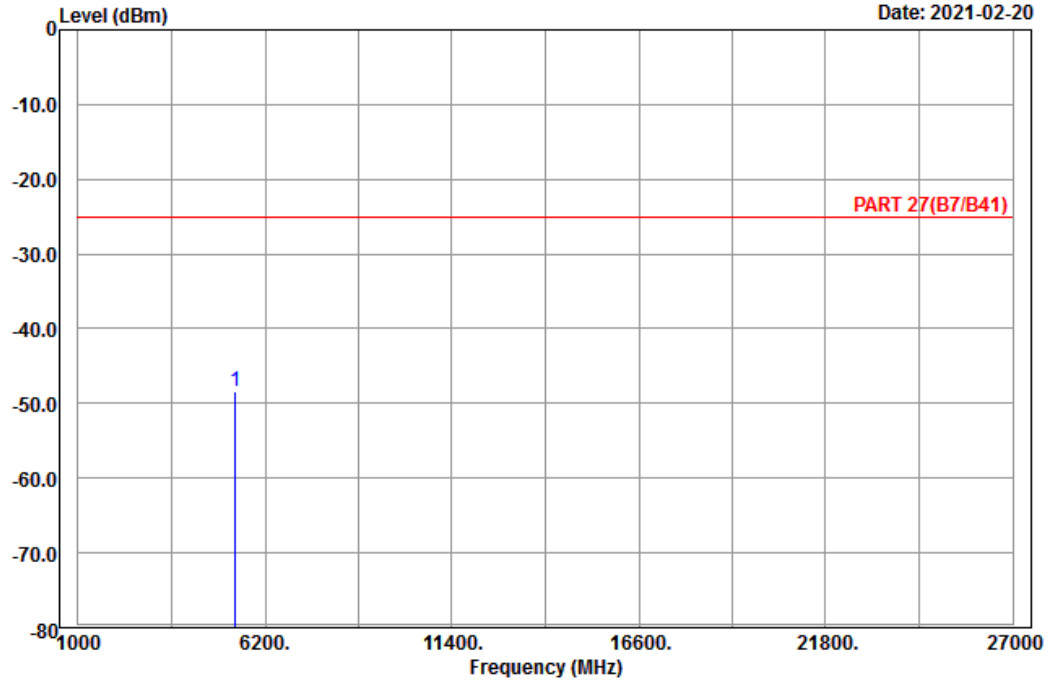

Site : 966 chamber 1
 Condition: PART 27(B7/B41) Vertical
 Remark : LTE_Band 41_Link_H-Ch
 Tested by: Charles Hsiao

Freq	Level	Read Level	Factor	Limit Line	Over Limit	Remark
MHz	dBm	dBm	dB	dBm	dB	
1 pp 5375.00	-48.31	-68.63	20.32	-25.00	-23.31	Peak

Channel Bandwidth: 20 MHz / QPSK
Low Channel



Bureau Veritas Consumer Products Services Ltd., Taoyuan Branch

A D T

Data: 3

Date: 2021-02-20

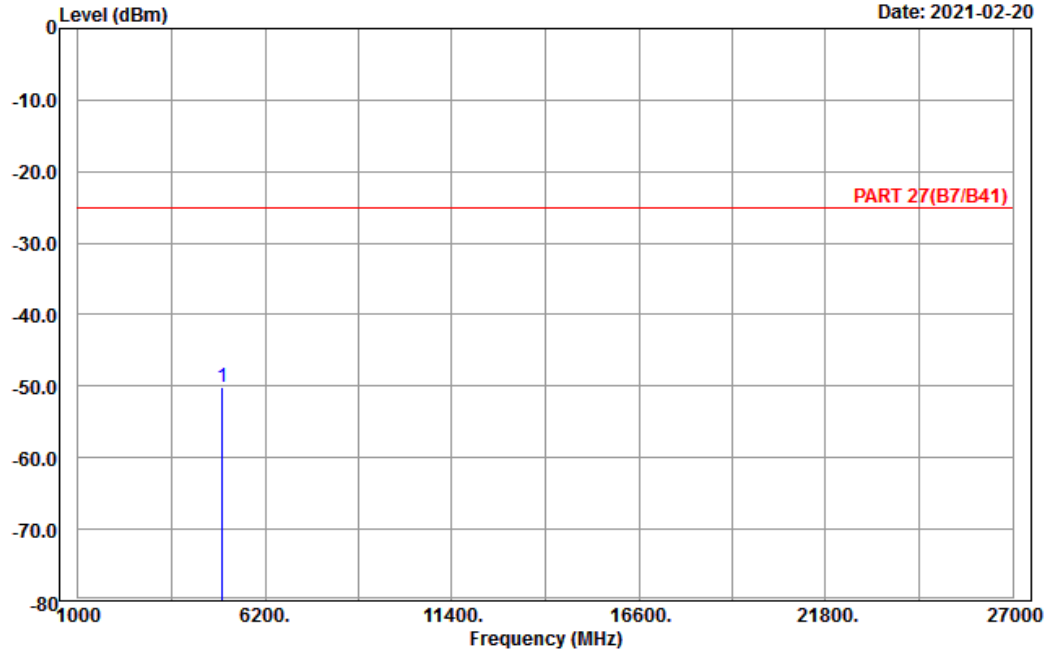

Site : 966 chamber 1
Condition: PART 27(B7/B41) Horizontal
Remark : LTE_Band 41_Link_L-Ch
Tested by: Charles Hsiao

	Freq	Level	Read Level	Factor	Limit Line	Over Limit	Remark
	MHz	dBm	dBm	dB	dBm	dB	
1 pp	5012.00	-50.17	-69.25	19.08	-25.00	-25.17	Peak



Bureau Veritas Consumer Products Services Ltd., Taoyuan Branch

A D T

Data: 4

Date: 2021-02-20

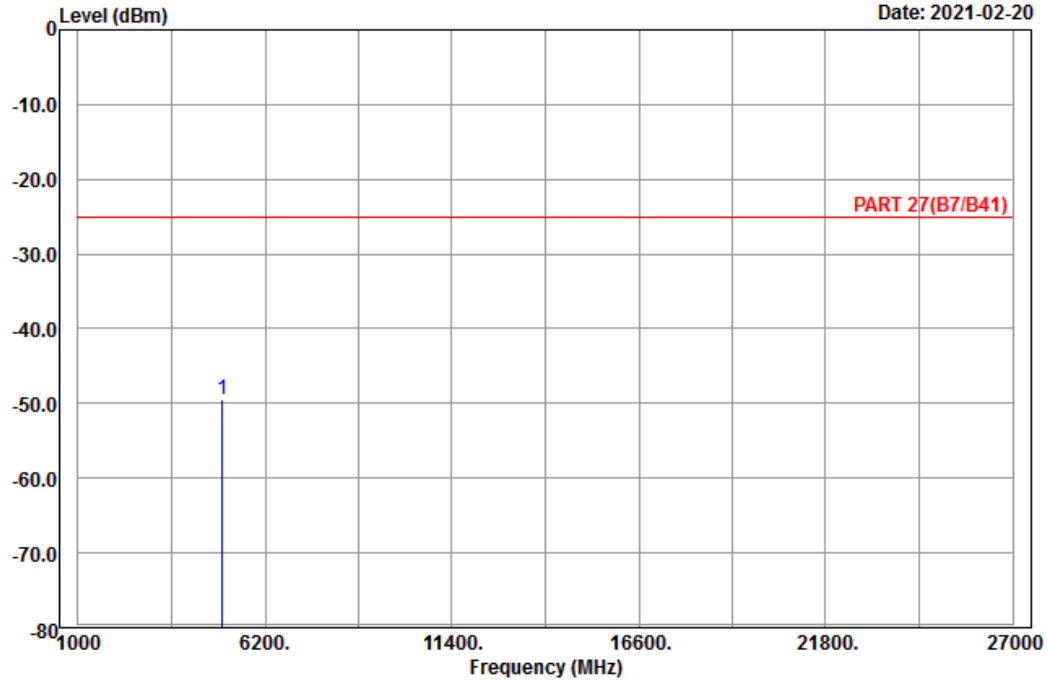

Site : 966 chamber 1
 Condition: PART 27(B7/B41) Vertical
 Remark : LTE_Band 41_Link_L-Ch
 Tested by: Charles Hsiao

Freq	Level	Read Level	Factor	Limit Line	Over Limit	Remark
MHz	dBm	dBm	dB	dBm	dB	
1 pp 5012.00	-49.45	-68.53	19.08	-25.00	-24.45	Peak

Middle Channel



Bureau Veritas Consumer Products Services Ltd., Taoyuan Branch

A D T

Data: 3

Date: 2021-02-20

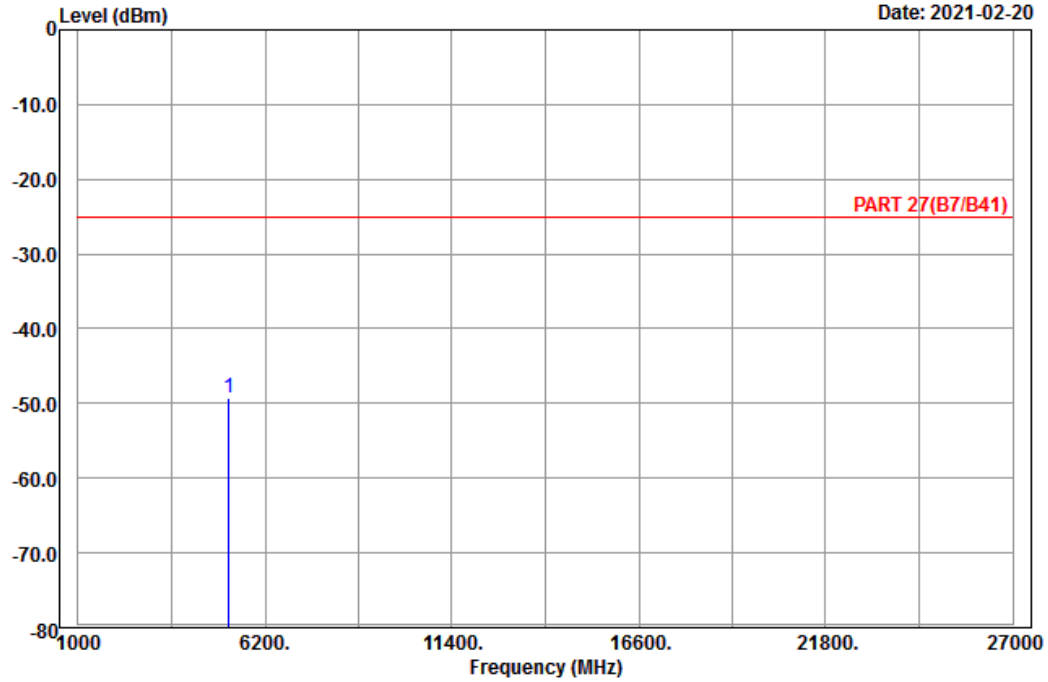

Site : 966 chamber 1
 Condition: PART 27(B7/B41) Horizontal
 Remark : LTE_Band 41_Link_M-Ch
 Tested by: Charles Hsiao

Freq	Level	Read Level	Factor	Limit Line	Over Limit	Remark
MHz	dBm	dBm	dB	dBm	dB	
1 pp 5186.00	-49.17	-69.29	20.12	-25.00	-24.17	Peak



Bureau Veritas Consumer Products Services Ltd., Taoyuan Branch

A D T

Data: 4

Date: 2021-02-20

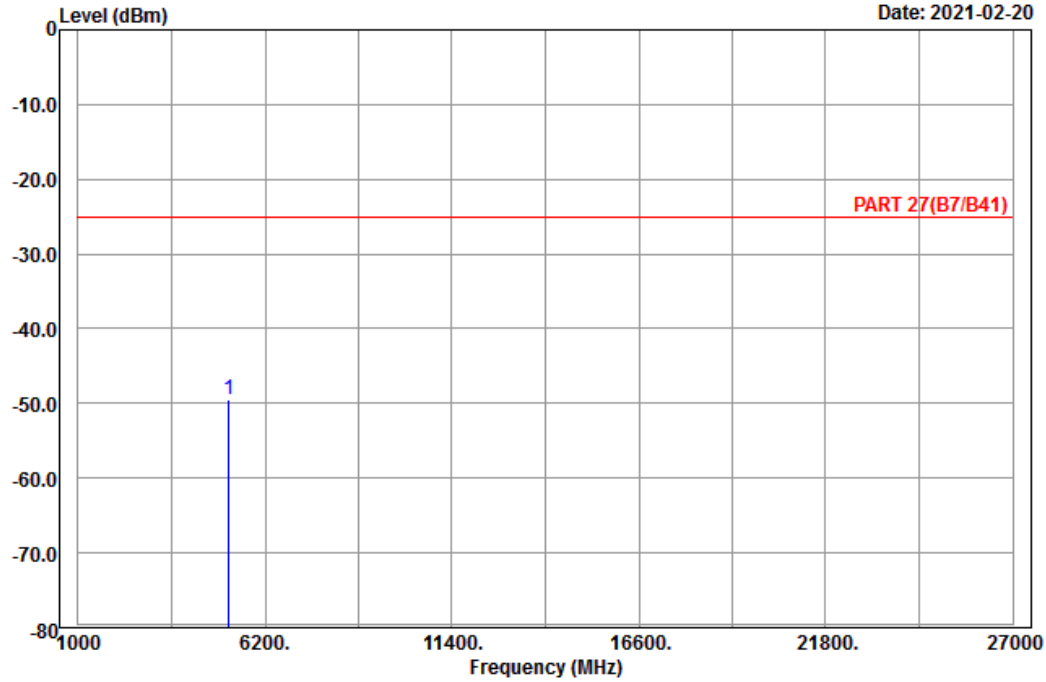

Site : 966 chamber 1
 Condition: PART 27(B7/B41) Vertical
 Remark : LTE_Band 41_Link_M-Ch
 Tested by: Charles Hsiao

Freq	Level	Read Level	Factor	Limit Line	Over Limit	Remark
MHz	dBm	dBm	dB	dBm	dB	
1 pp 5186.00	-49.59	-69.71	20.12	-25.00	-24.59	Peak

High Channel



Bureau Veritas Consumer Products Services Ltd., Taoyuan Branch

A D T

Data: 7

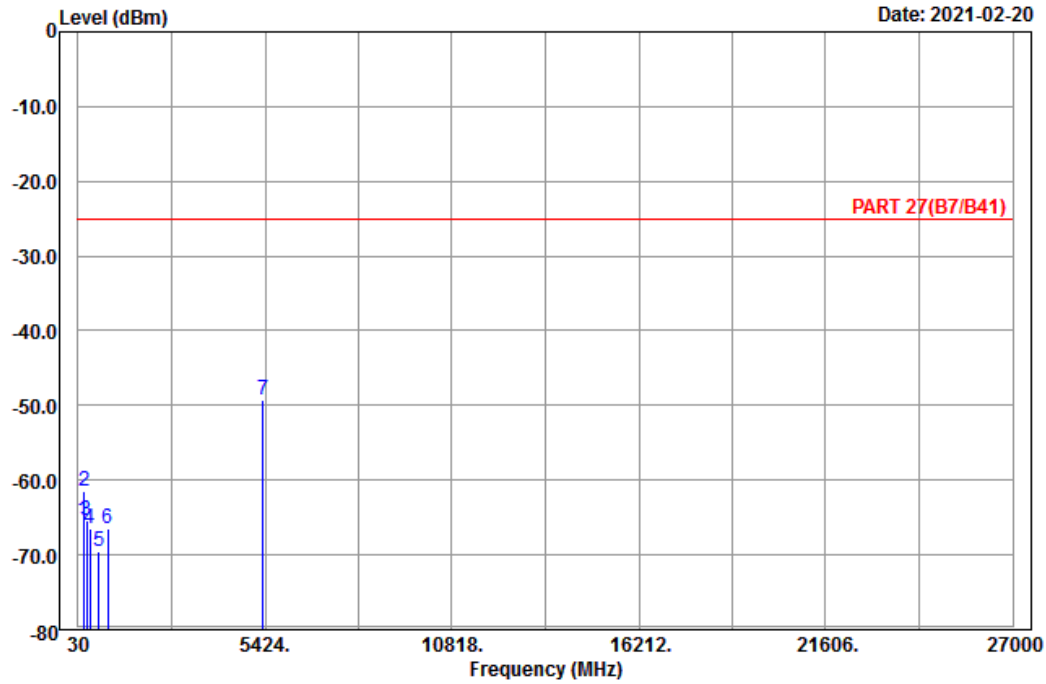

Site : 966 chamber 1
 Condition: PART 27(B7/B41) Horizontal
 Remark : LTE_Band 41_Link_M-Ch
 Tested by: Charles Hsiao

	Freq	Level	Read Level	Factor	Limit Line	Over Limit	Remark
	MHz	dBm	dBm	dB	dBm	dB	
1	189.84	-65.50	-59.77	-5.73	-25.00	-40.50	Peak
2	213.33	-61.58	-55.58	-6.00	-25.00	-36.58	Peak
3	268.68	-65.32	-59.64	-5.68	-25.00	-40.32	Peak
4	370.00	-66.51	-62.22	-4.29	-25.00	-41.51	Peak
5	631.10	-69.48	-69.55	0.07	-25.00	-44.48	Peak
6	876.10	-66.57	-68.77	2.20	-25.00	-41.57	Peak
7 pp	5360.00	-49.17	-69.47	20.30	-25.00	-24.17	Peak



Bureau Veritas Consumer Products Services Ltd., Taoyuan Branch

A D T

Data: 8

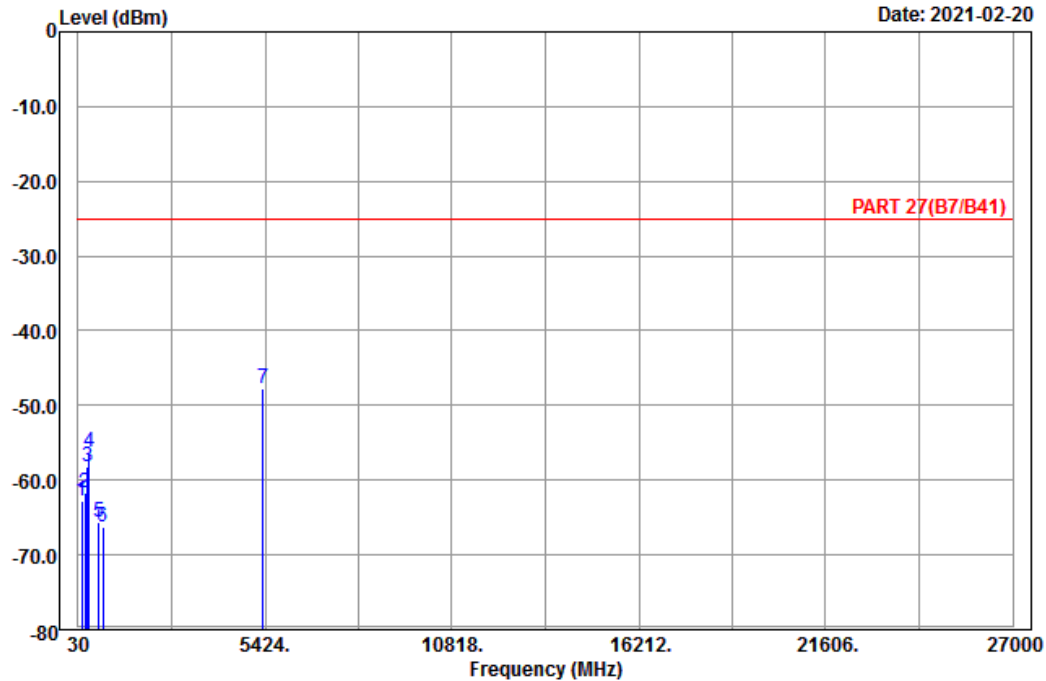

Site : 966 chamber 1
 Condition: PART 27(B7/B41) Vertical
 Remark : LTE_Band 41_Link_H-Ch
 Tested by: Charles Hsiao

	Freq	Level	Read Level	Factor	Limit Line	Over Limit	Remark
	MHz	dBm	dBm	dB	dBm	dB	
1	135.03	-62.80	-55.13	-7.67	-25.00	-37.80	Peak
2	229.80	-61.63	-55.85	-5.78	-25.00	-36.63	Peak
3	288.93	-58.15	-52.29	-5.86	-25.00	-33.15	Peak
4	342.70	-56.20	-50.73	-5.47	-25.00	-31.20	Peak
5	639.50	-65.62	-65.61	-0.01	-25.00	-40.62	Peak
6	744.50	-66.35	-65.13	-1.22	-25.00	-41.35	Peak
7 pp	5360.00	-47.72	-68.02	20.30	-25.00	-22.72	Peak

5 Pictures of Test Arrangements

Please refer to the attached file (Test Setup Photo).

Appendix – Information of the Testing Laboratories

We, Bureau Veritas Consumer Products Services (H.K.) Ltd., Taoyuan Branch, were founded in 1988 to provide our best service in EMC, Radio, Telecom and Safety consultation. Our laboratories are FCC recognized accredited test firms and accredited according to ISO/IEC 17025.

If you have any comments, please feel free to contact us at the following:

Lin Kou EMC/RF Lab

Tel: 886-2-26052180

Fax: 886-2-26051924

Hsin Chu EMC/RF/Telecom Lab

Tel: 886-3-6668565

Fax: 886-3-6668323

Hwa Ya EMC/RF/Safety Lab

Tel: 886-3-3183232

Fax: 886-3-3270892

Email: service.adt@tw.bureauveritas.com

Web Site: www.bureauveritas-adt.com

The address and road map of all our labs can be found in our web site also.

--- END ---