

802.11ax (HE40)

Channel	Frequency (MHz)	PSD (dBm/MHz)	Maximum Limit (dBm/MHz)	Pass / Fail
38	5190	3.60	11	Pass
46	5230	3.62	11	Pass
54	5270	3.58	11	Pass
62	5310	1.93	11	Pass
102	5510	-0.22	11	Pass
110	5550	-0.12	11	Pass
134	5670	0.02	11	Pass
142	5710 (U-NII-2C)	2.24	11	Pass

802.11ax (HE80):

Channel	Frequency (MHz)	PSD (dBm/MHz)	Maximum Limit (dBm/MHz)	Pass / Fail
42	5210	0.92	11	Pass
58	5290	0.25	11	Pass
106	5530	-2.88	11	Pass
122	5610	-2.70	11	Pass
138	5690 (U-NII-2C)	-2.84	11	Pass

802.11ax (HE160):

Channel	Frequency (MHz)	PSD (dBm/MHz)	Maximum Limit (dBm/MHz)	Pass / Fail
50	5250 (U-NII-1)	-4.30	11	Pass
50	5250 (U-NII-2A)	-4.40	11	Pass
114	5570	-5.15	11	Pass

Spectrum Plot of Worst Value

802.11a

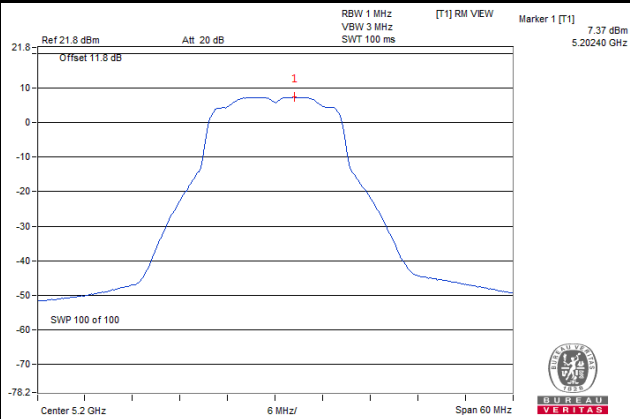

802.11ax (HE20)

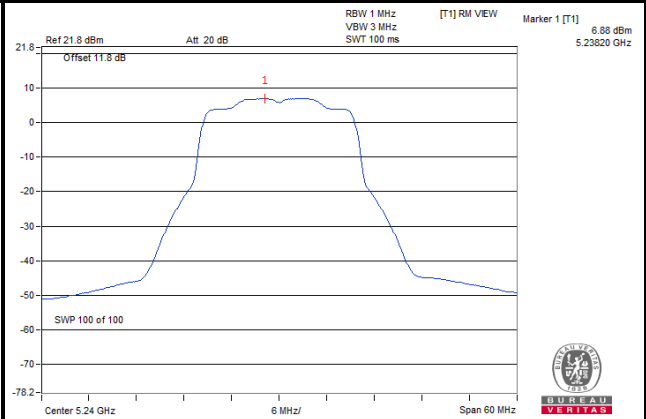

802.11ax (HE40)

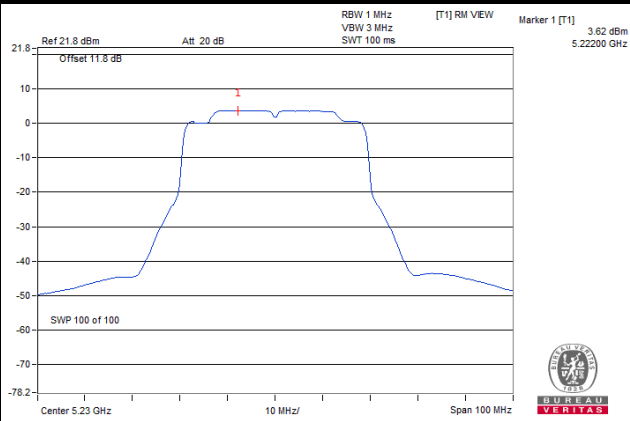

802.11ax (HE80)

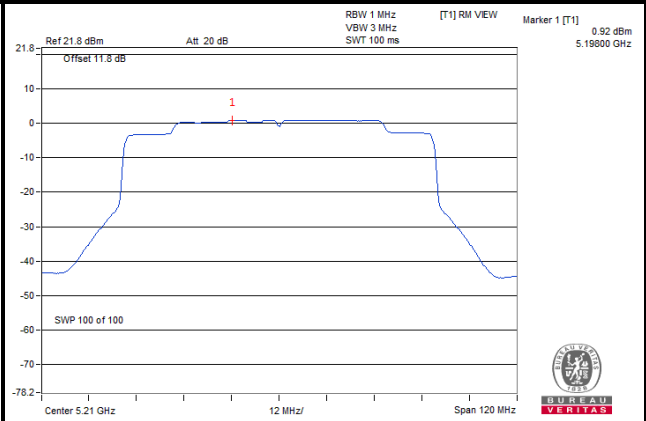

802.11ax (HE160)

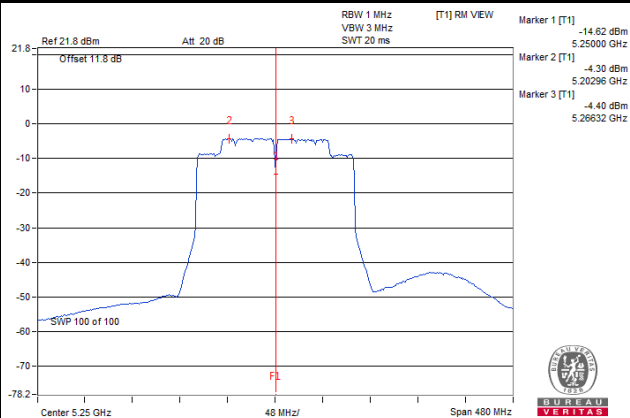

For U-NII-3 Band

802.11a

Channel	Frequency (MHz)	PSD w/o Duty Factor		Duty Factor (dB)	PSD with Duty Factor (dBm/500 kHz)	Limit (dBm/500 kHz)	Pass / Fail
		(dBm/300 kHz)	(dBm/500 kHz)				
149	5745	-0.31	1.91	0.1	2.01	30	Pass
157	5785	0.03	2.25	0.1	2.35	30	Pass
165	5825	0.01	2.23	0.1	2.33	30	Pass

Note: Refer to section 3.3 for duty cycle spectrum plot.

802.11ax (HE20)

Channel	Freq. (MHz)	PSD (dBm/300 kHz)	PSD (dBm/500 kHz)	Limit (dBm/500 kHz)	Pass / Fail
144	5720 (U-NII-3)	-3.61	-1.39	30	Pass
149	5745	-0.91	1.31	30	Pass
157	5785	-0.62	1.6	30	Pass
165	5825	-0.81	1.41	30	Pass

802.11ax (HE40)

Channel	Freq. (MHz)	PSD (dBm/300 kHz)	PSD (dBm/500 kHz)	Limit (dBm/500 kHz)	Pass / Fail
142	5710 (U-NII-3)	-5.24	-3.02	30	Pass
151	5755	-4.09	-1.87	30	Pass
159	5795	-3.89	-1.67	30	Pass

802.11ax (HE80)

Channel	Freq. (MHz)	PSD (dBm/300 kHz)	PSD (dBm/500 kHz)	Limit (dBm/500 kHz)	Pass / Fail
138	5690 (U-NII-3)	-12.05	-9.83	30	Pass
155	5775	-6.64	-4.42	30	Pass

Spectrum Plot of Worst Value

802.11a

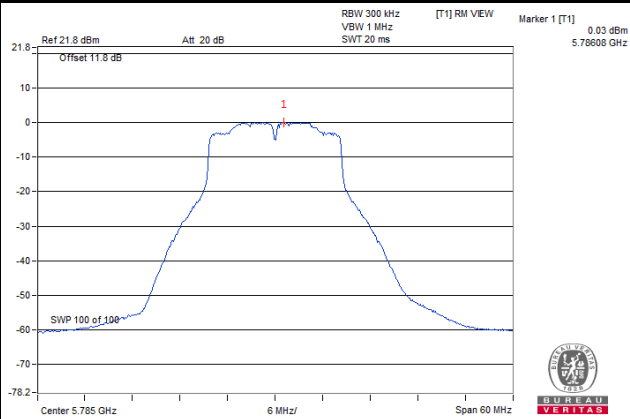

802.11ax (HE20)

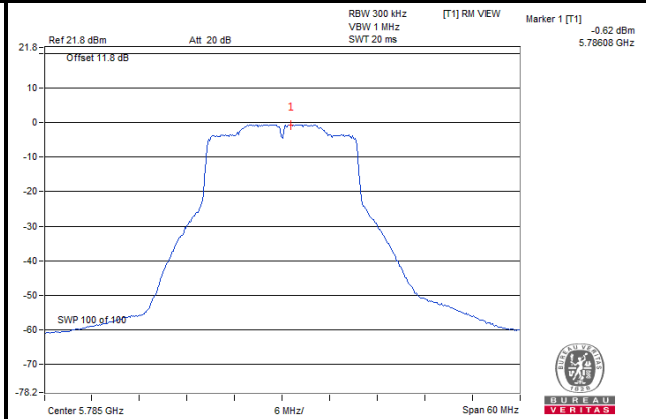

802.11ax (HE40)

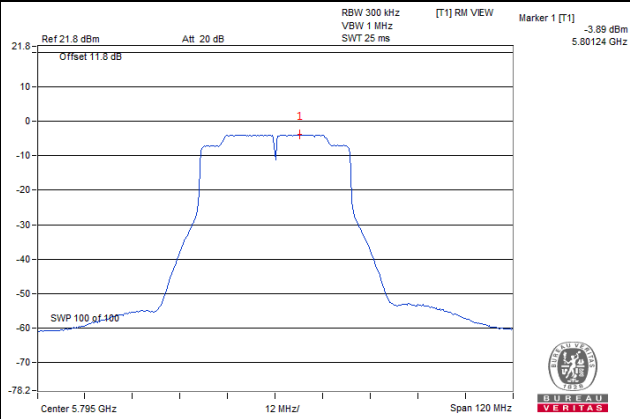

802.11ax (HE80)

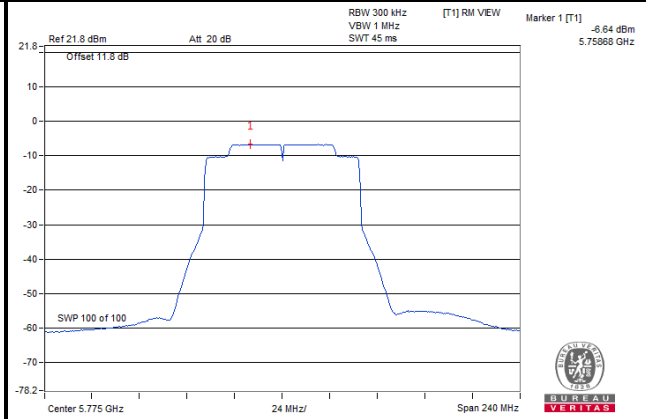

4.6 Frequency Stability

4.6.1 Limit of Frequency Stability Measurement

The frequency of the carrier signal shall be maintained within band of operation.

4.6.2 Test Setup

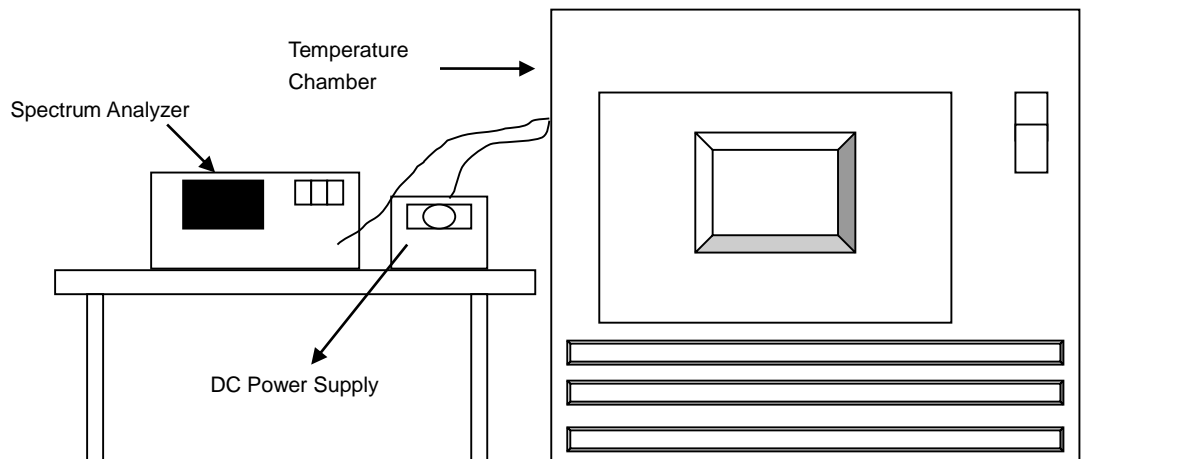

4.6.3 Test Instruments

Refer to section 4.1.2 to get information of above instrument.

4.6.4 Test Procedure

- The EUT was placed inside the environmental test chamber and powered by nominal DC voltage.
- Turn the EUT on and couple its output to a spectrum analyzer.
- Turn the EUT off and set the chamber to the highest temperature specified.
- Allow sufficient time (approximately 30 min) for the temperature of the chamber to stabilize, turn the EUT on and measure the operating frequency after 2, 5, and 10 Minutes.
- Repeat step (d) with the temperature chamber set to the next desired temperature until measurements down to the lowest specified temperature have been completed.
- The test chamber was allowed to stabilize at +20 degree C for a minimum of 30 Minutes. The supply voltage was then adjusted on the EUT from 85% to 115% and the frequency record.

4.6.5 Deviation from Test Standard

No deviation.

4.6.6 EUT Operating Condition

Set the EUT transmit at un-modulation mode to test frequency stability.

4.6.7 Test Results

Frequency Stability Versus Temp.									
Operating Frequency: 5180 MHz									
Temp. (°C)	Power Supply (Vdc)	0 Minute		2 Minute		5 Minute		10 Minute	
		Measured Frequency (MHz)	Result	Measured Frequency (MHz)	Result	Measured Frequency (MHz)	Result	Measured Frequency (MHz)	Result
40	14.4	5180.0149	PASS	5180.0159	PASS	5180.012	PASS	5180.0141	PASS
30	14.4	5180.01	PASS	5180.0101	PASS	5180.0114	PASS	5180.0078	PASS
20	14.4	5179.9818	PASS	5179.9828	PASS	5179.9813	PASS	5179.9826	PASS
10	14.4	5179.9773	PASS	5179.9725	PASS	5179.9737	PASS	5179.9757	PASS
0	14.4	5180.0228	PASS	5180.0231	PASS	5180.0192	PASS	5180.0231	PASS

Frequency Stability Versus Voltage									
Operating Frequency: 5180 MHz									
Temp. (°C)	Power Supply (Vdc)	0 Minute		2 Minute		5 Minute		10 Minute	
		Measured Frequency (MHz)	Result	Measured Frequency (MHz)	Result	Measured Frequency (MHz)	Result	Measured Frequency (MHz)	Result
20	16.56	5179.981	PASS	5179.983	PASS	5179.981	PASS	5179.982	PASS
	14.4	5179.9818	PASS	5179.9828	PASS	5179.9813	PASS	5179.9826	PASS
	12.24	5179.9816	PASS	5179.9831	PASS	5179.9819	PASS	5179.983	PASS

4.7 6 dB Bandwidth Measurement

4.7.1 Limits of 6 dB Bandwidth Measurement

The minimum of 6 dB Bandwidth Measurement is 0.5 MHz.

4.7.2 Test Setup

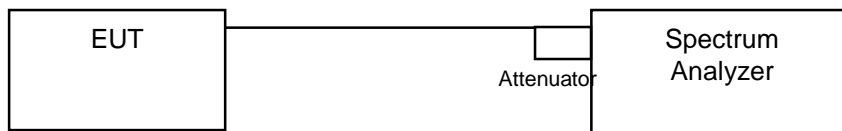

4.7.3 Test Instruments

Refer to section 4.1.2 to get information of above instrument.

4.7.4 Test Procedure

MEASUREMENT PROCEDURE REF

- Set resolution bandwidth (RBW) = 100 kHz
- Set the video bandwidth (VBW) $\geq 3 \times$ RBW, Detector = Peak.
- Trace mode = max hold.
- Sweep = auto couple.
- Measure the maximum width of the emission that is constrained by the frequencies associated with the two amplitude points (upper and lower) that are attenuated by 6 dB relative to the maximum level measured in the fundamental emission

4.7.5 Deviation from Test Standard

No deviation.

4.7.6 EUT Operating Condition

The software provided by client to enable the EUT under transmission condition continuously at lowest, middle and highest channel frequencies individually.

4.7.7 Test Results

802.11a

Channel	Frequency (MHz)	6 dB Bandwidth (MHz)	Minimum Limit (MHz)	Pass / Fail
149	5745	15.19	0.5	Pass
157	5785	15.19	0.5	Pass
165	5825	15.18	0.5	Pass

802.11ax (HE20)

Channel	Frequency (MHz)	6 dB Bandwidth (MHz)	Minimum Limit (MHz)	Pass / Fail
144	5720 (U-NII-3)	3.72	0.5	Pass
149	5745	16.79	0.5	Pass
157	5785	17.58	0.5	Pass
165	5825	16.07	0.5	Pass

802.11ax (HE40)

Channel	Frequency (MHz)	6 dB Bandwidth (MHz)	Minimum Limit (MHz)	Pass / Fail
142	5710 (U-NII-3)	2.56	0.5	Pass
151	5755	35.68	0.5	Pass
159	5795	35.80	0.5	Pass

802.11ax (HE80)

Channel	Frequency (MHz)	6 dB Bandwidth (MHz)	Minimum Limit (MHz)	Pass / Fail
138	5690 (U-NII-3)	1.45	0.5	Pass
155	5775	74.06	0.5	Pass

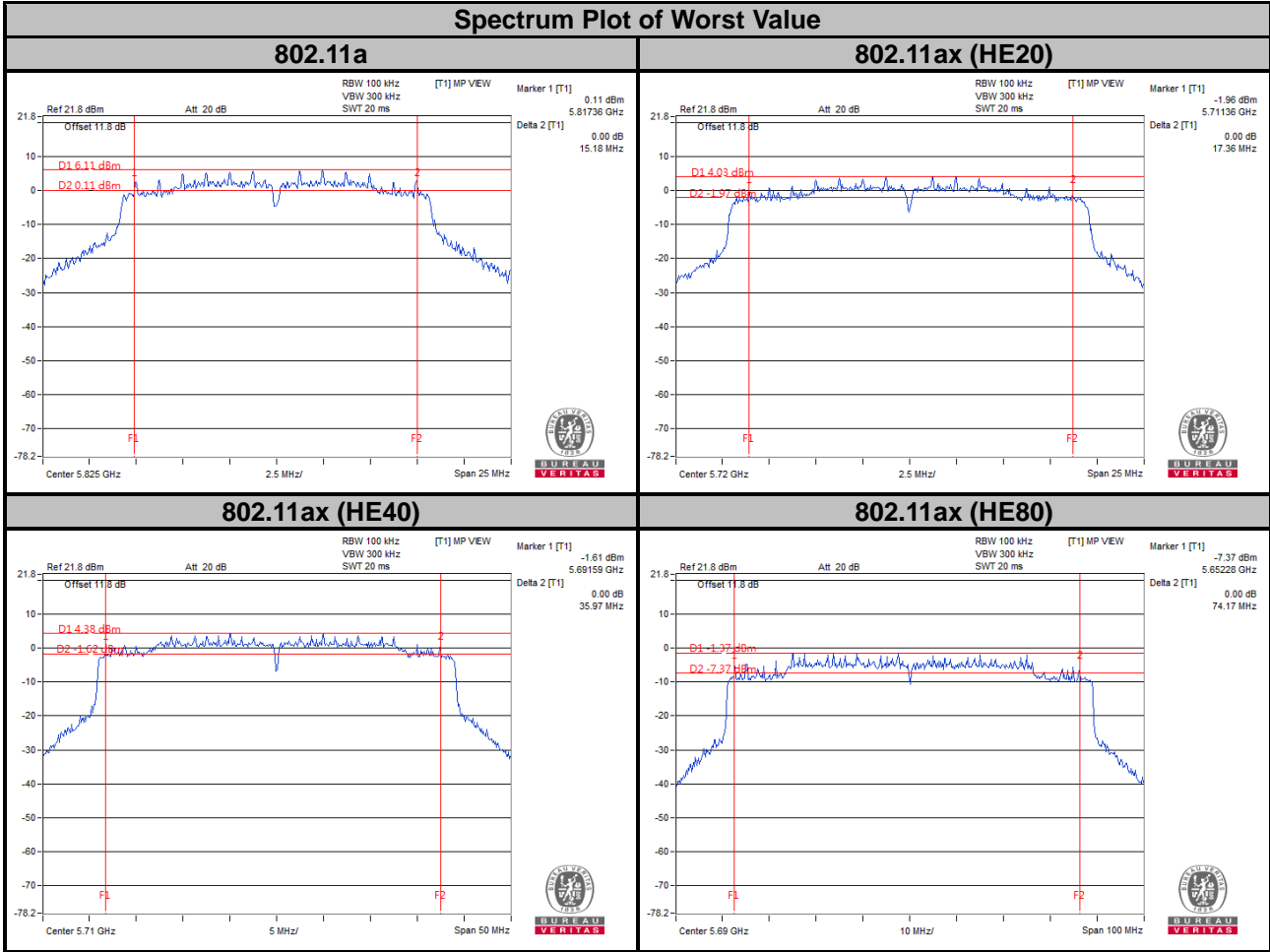

Note:

For Ch138 (UNII-3 Band): The 6 dB bandwidth above 5725 MHz = Marker 1 + Delta 2 – 5725 MHz
 For Ch144 (UNII-3 Band): The 6 dB bandwidth above 5725 MHz = Marker 1 + Delta 2 – 5725 MHz
 For Ch142 (UNII-3 Band): The 6 dB bandwidth above 5725 MHz = Marker 1 + Delta 2 – 5725 MHz

5 Pictures of Test Arrangements

Please refer to the attached file (Test Setup Photo).

Annex A- Radiated Out of Band Emission (OOBE) Measurement (For U-NII-3 band)

802.11a

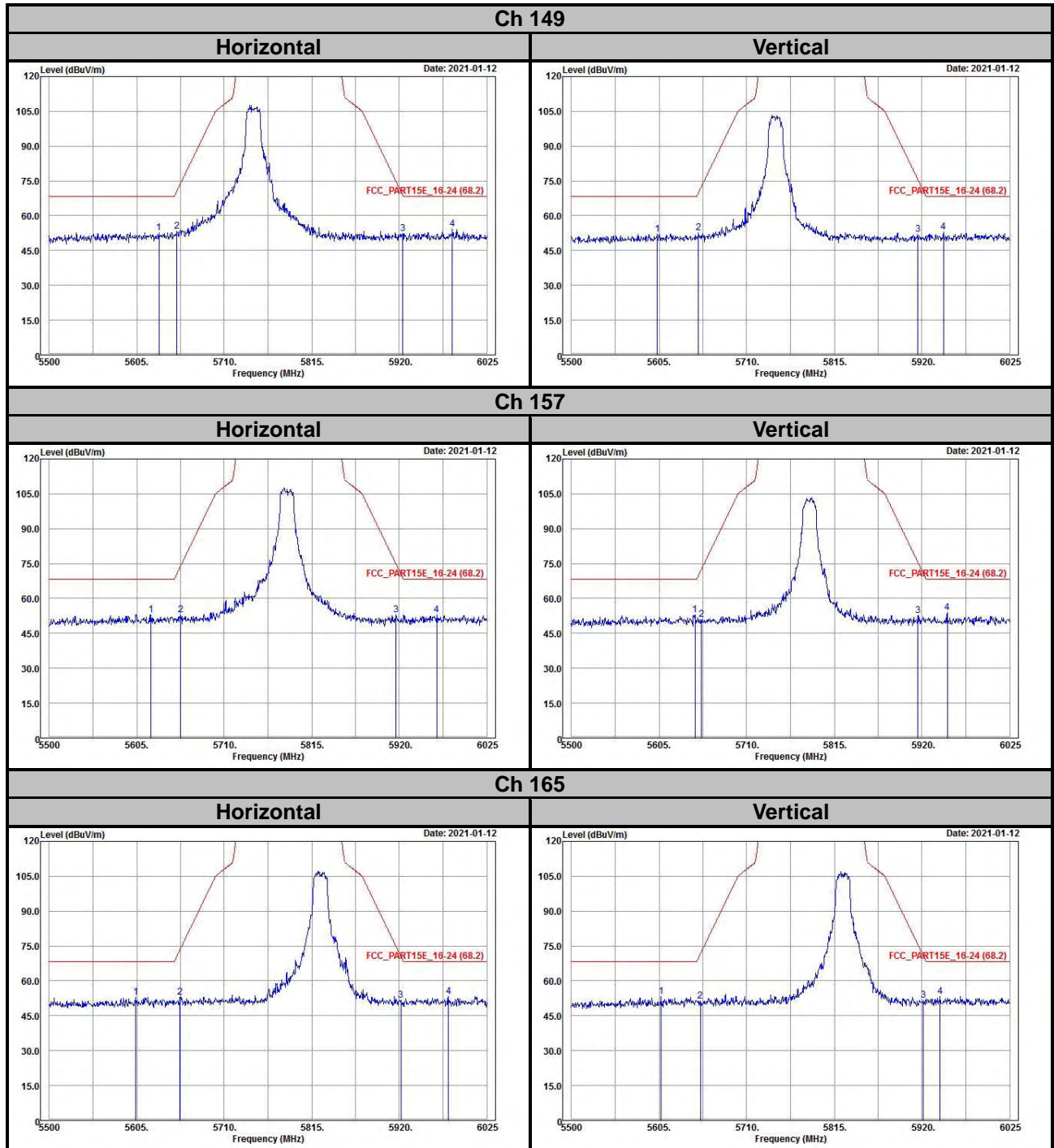

802.11ax (HE20)

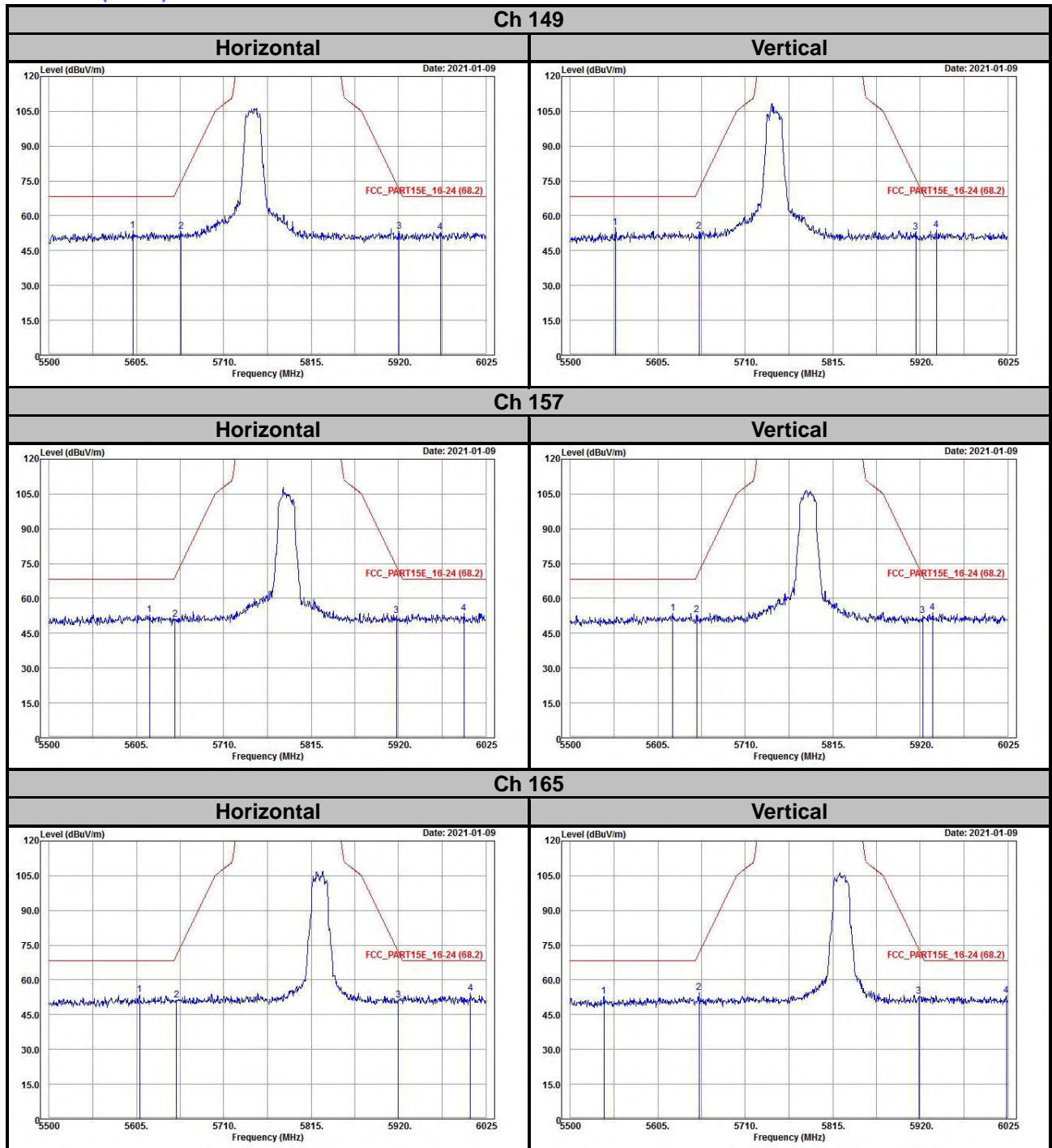

802.11ax (HE40)

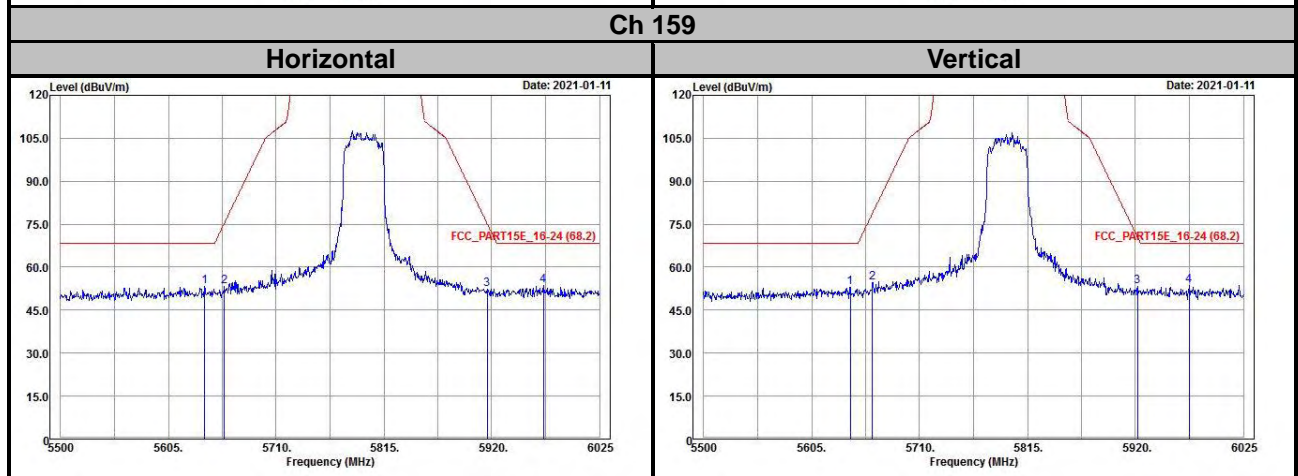
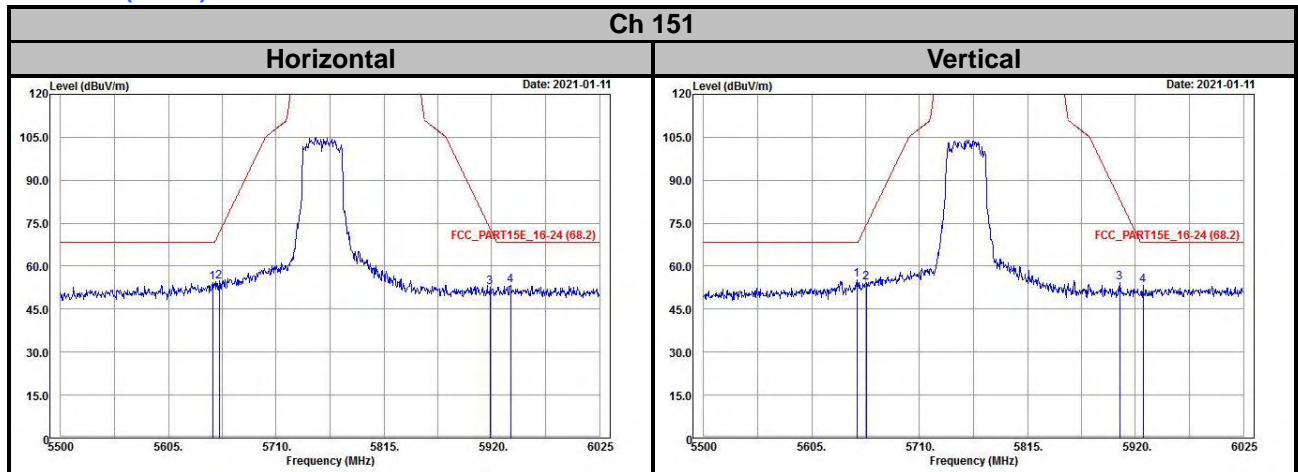

802.11ax (HE80)

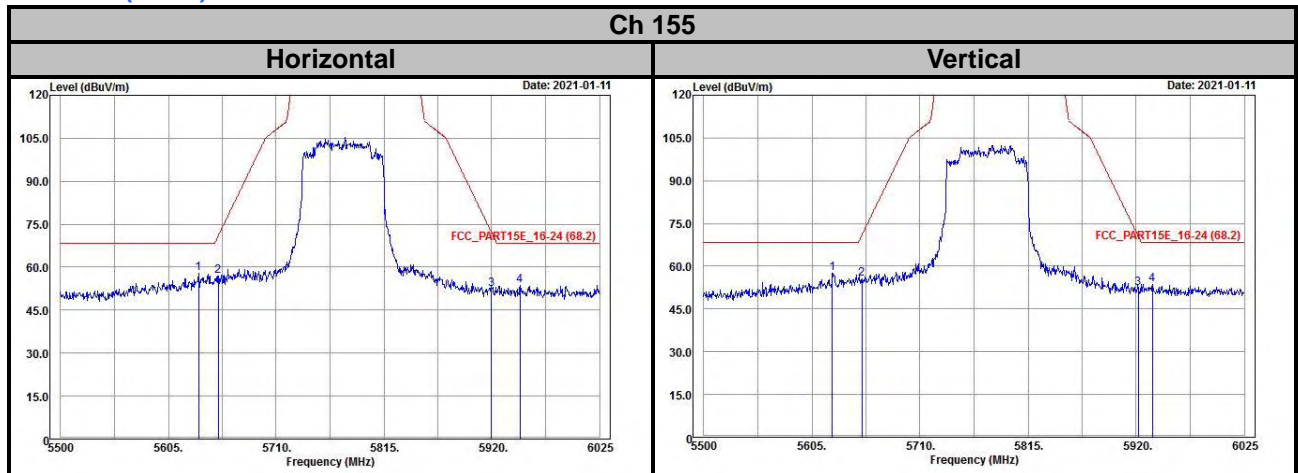

Annex B- Band-edge measurement (For U-NII-1, U-NII-2A, U-NII-2C band)

802.11a

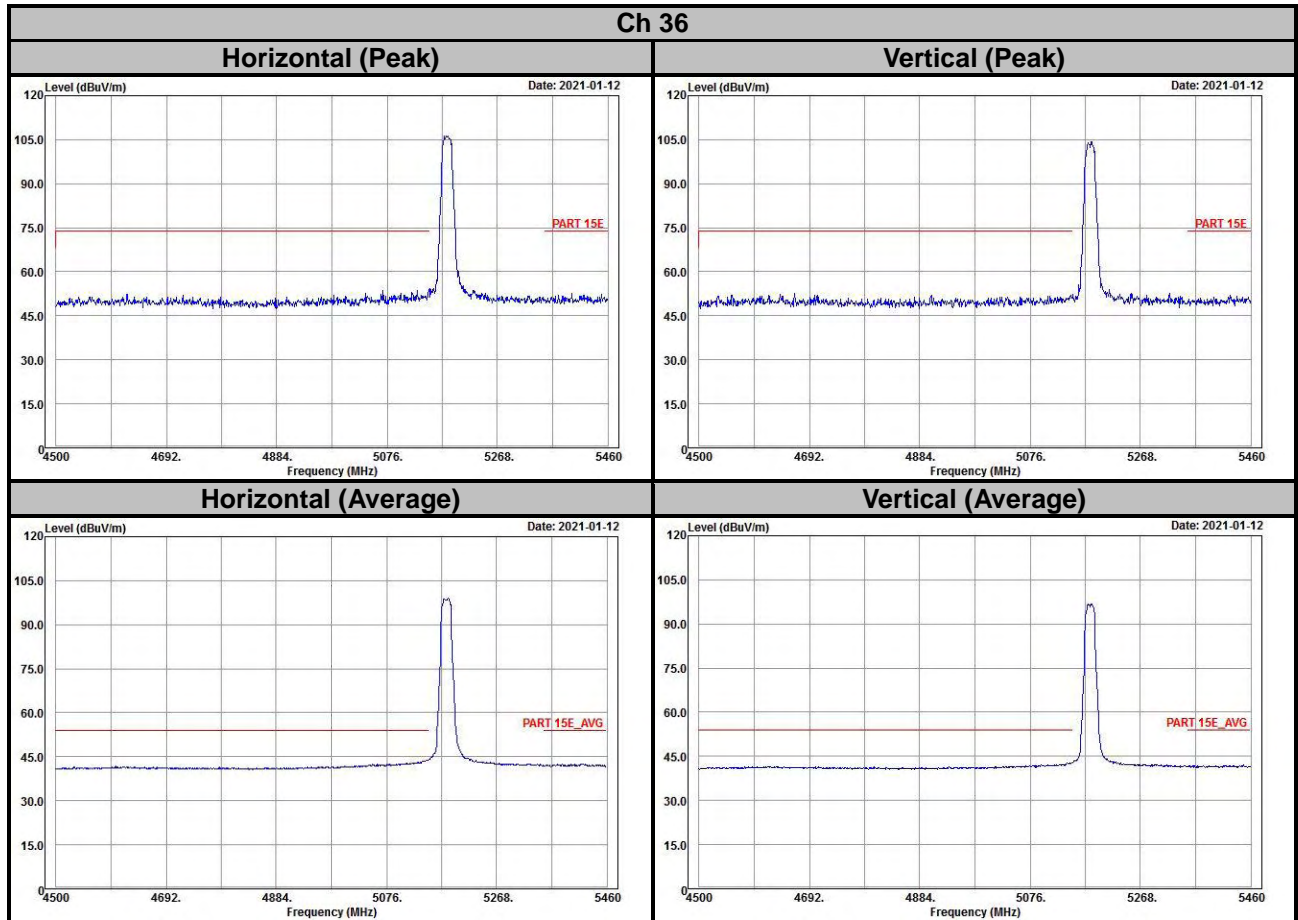

Ch 40

Horizontal (Peak)

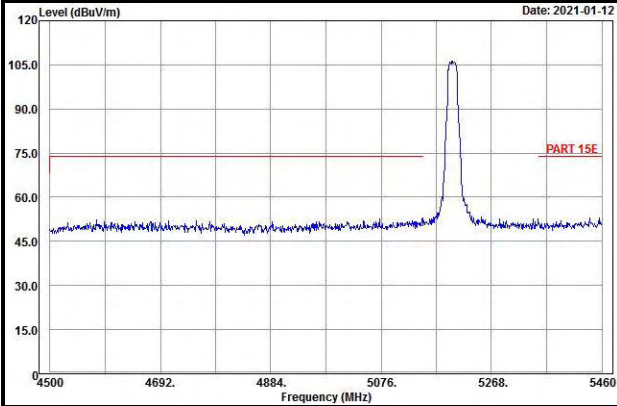

Vertical (Peak)

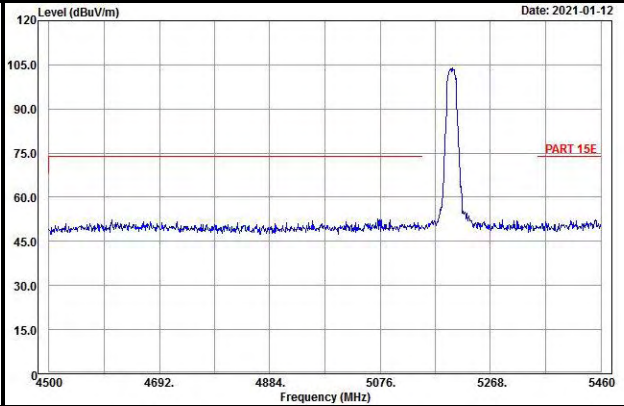

Horizontal (Average)

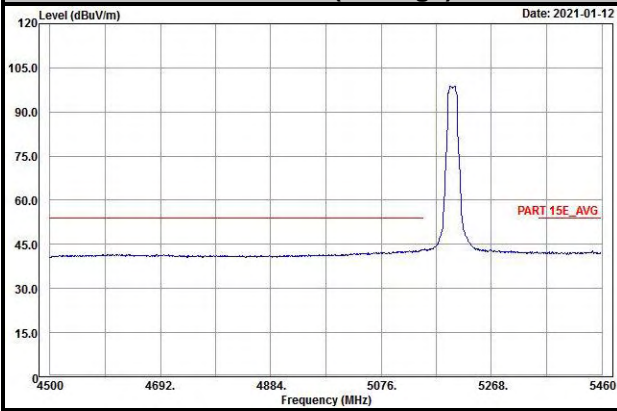

Vertical (Average)

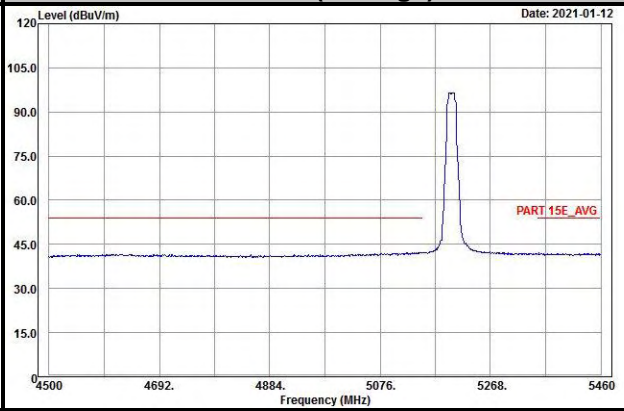

Ch 48

Horizontal (Peak)

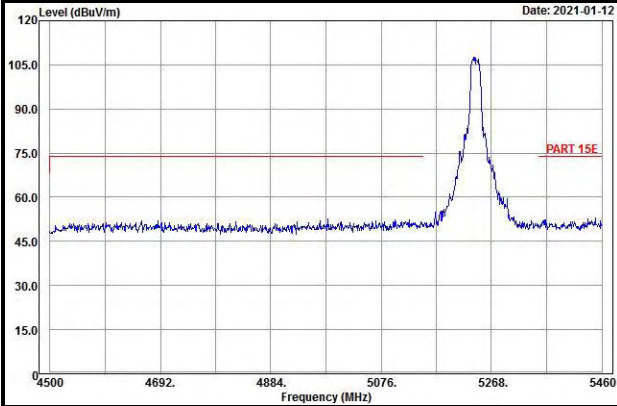

Vertical (Peak)

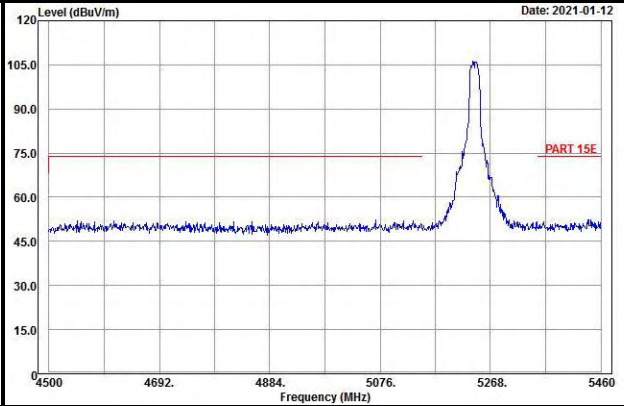

Horizontal (Average)

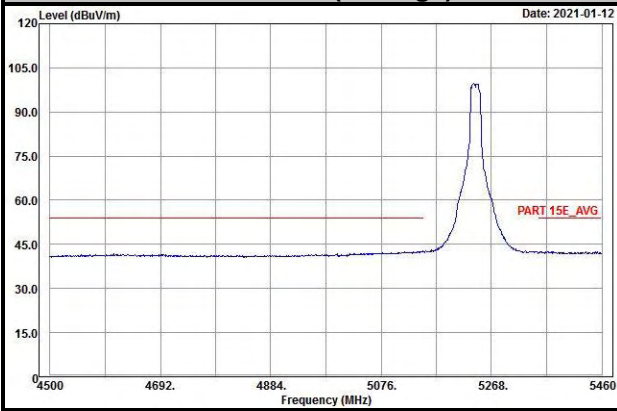

Vertical (Average)

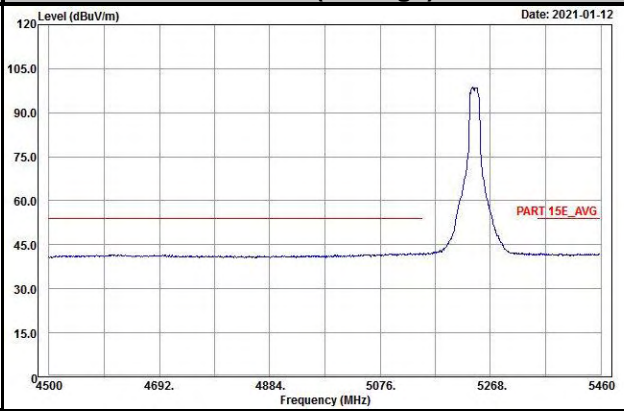

Ch 52

Horizontal (Peak)

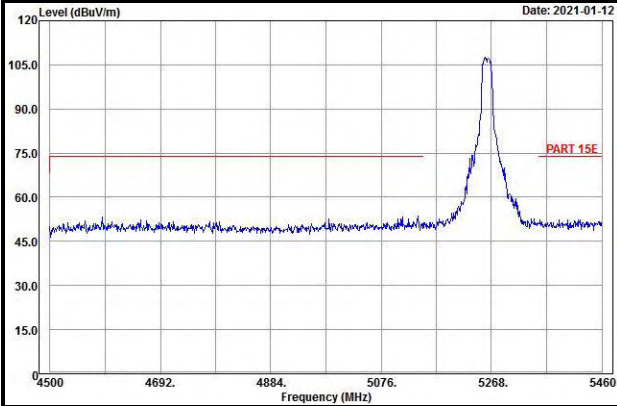

Vertical (Peak)

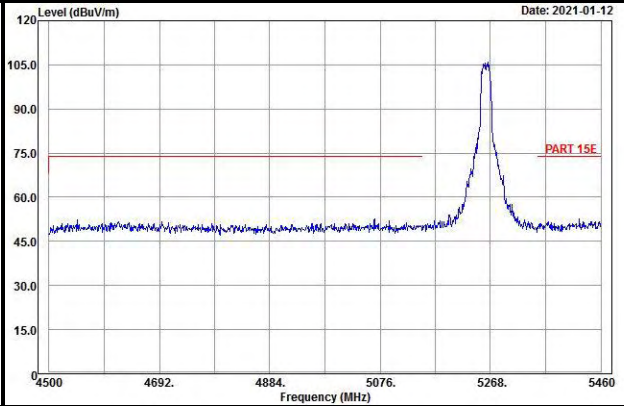

Horizontal (Average)

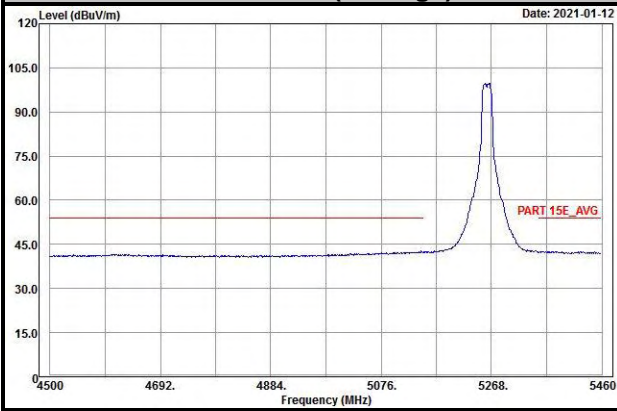

Vertical (Average)

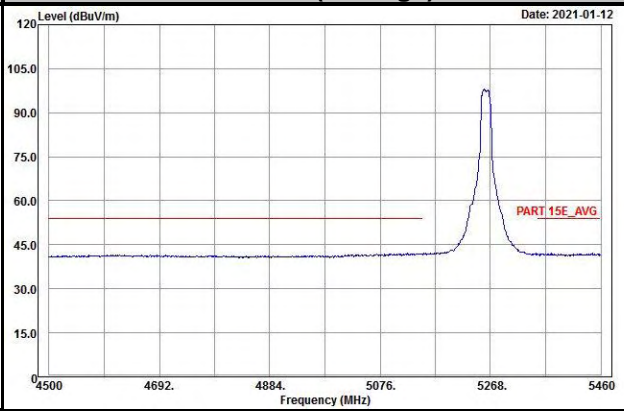

Ch 60

Horizontal (Peak)

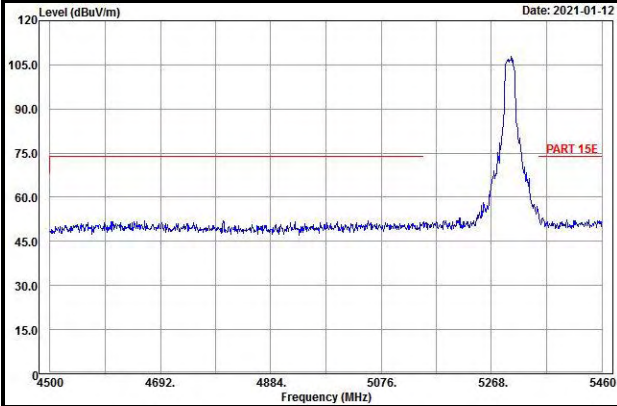

Vertical (Peak)

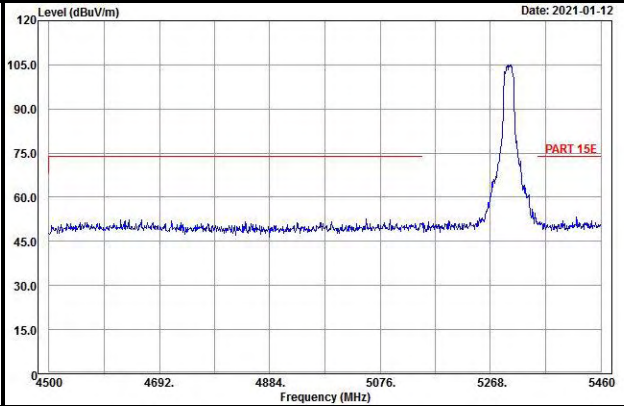

Horizontal (Average)

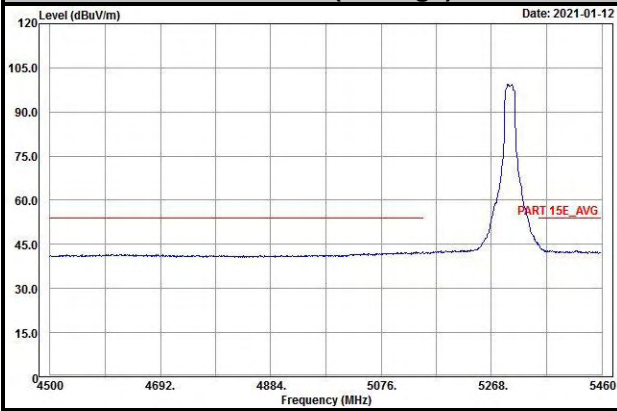

Vertical (Average)

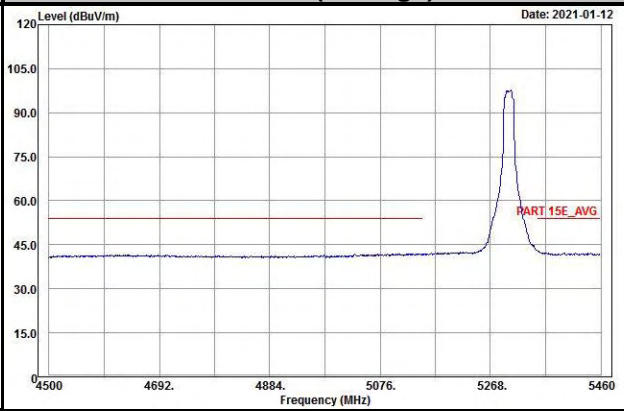

Ch 64

Horizontal (Peak)

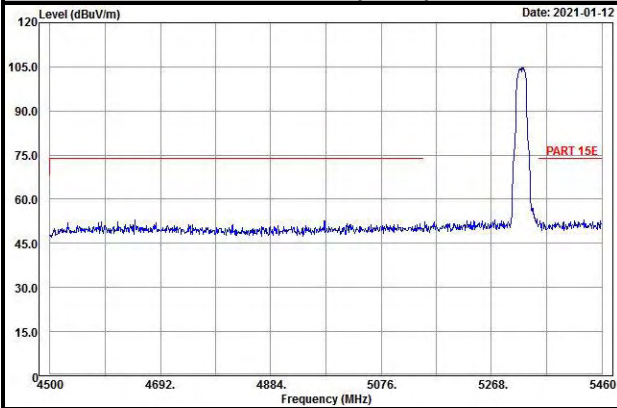

Vertical (Peak)

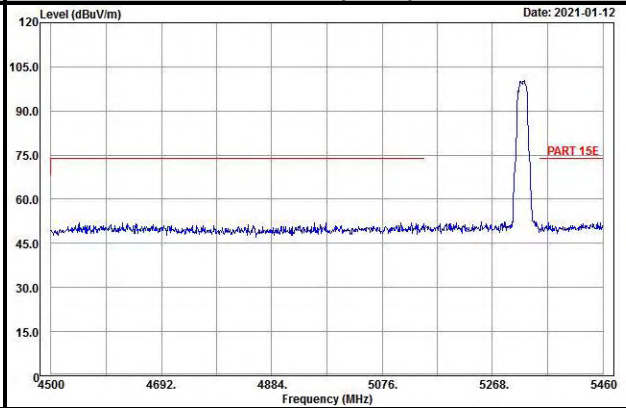

Horizontal (Average)

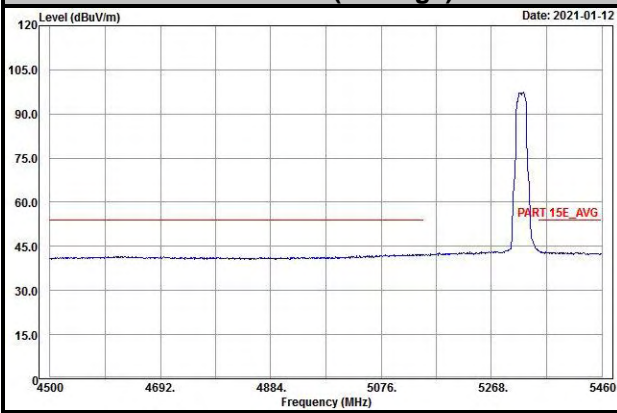

Vertical (Average)

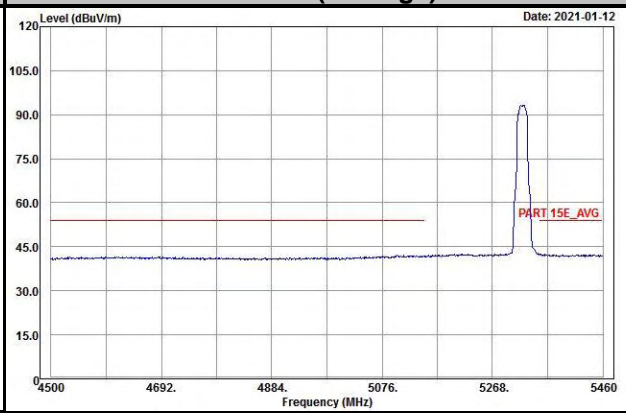

Ch 100

Horizontal (Peak)

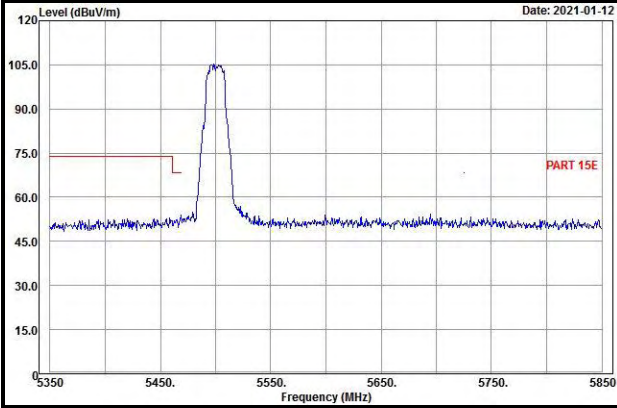

Vertical (Peak)

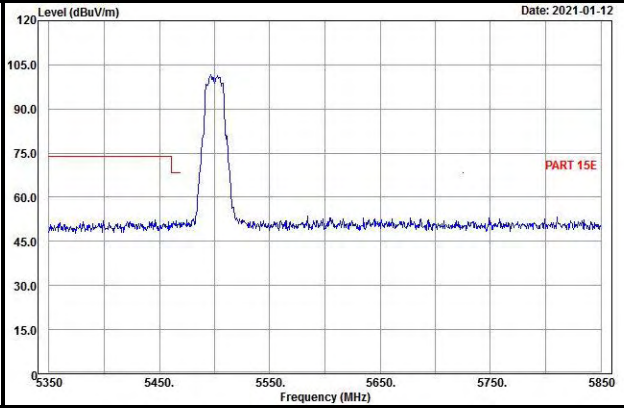

Horizontal (Average)

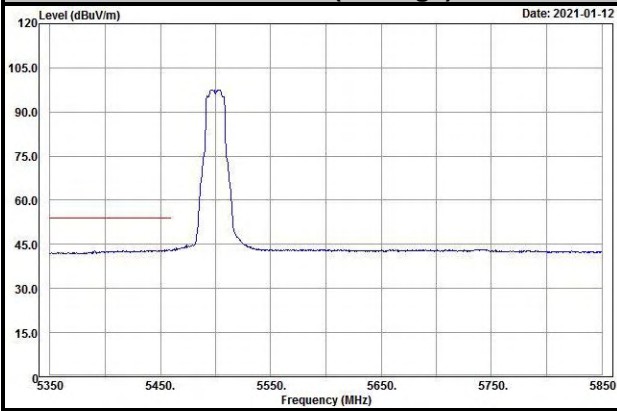

Vertical (Average)

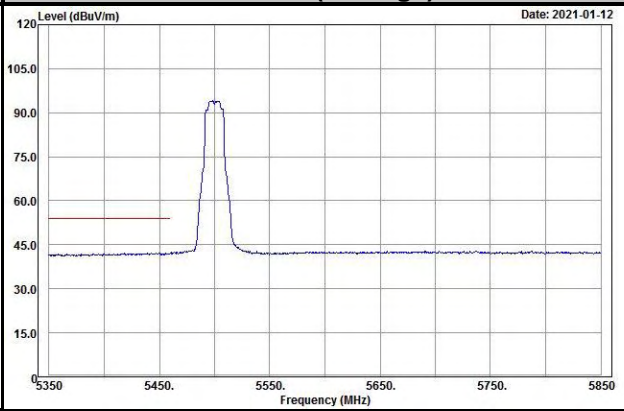

Ch 116

Horizontal (Peak)

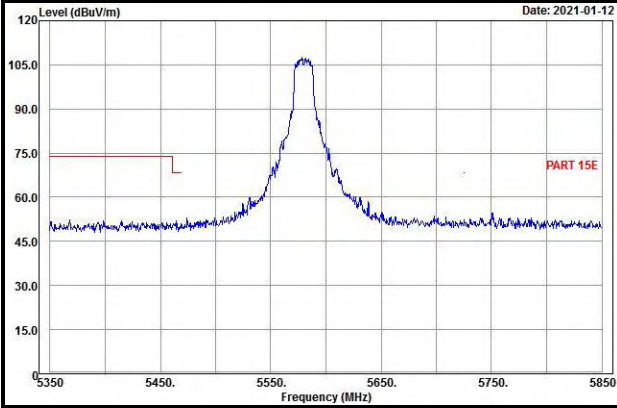

Vertical (Peak)

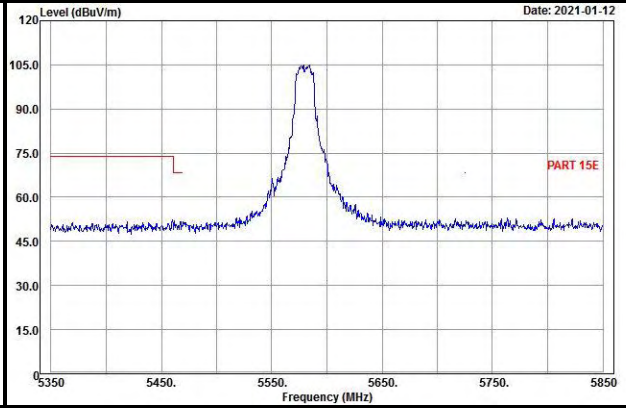

Horizontal (Average)

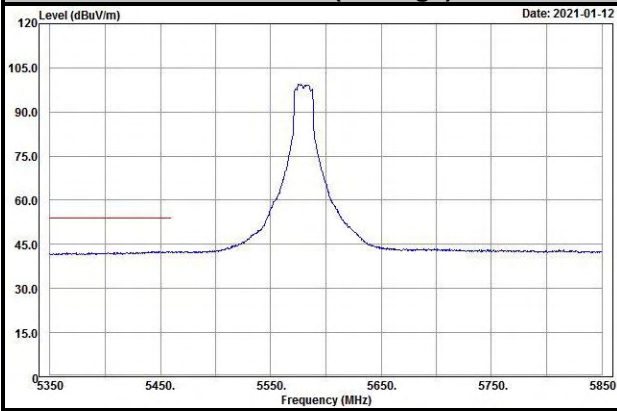

Vertical (Average)

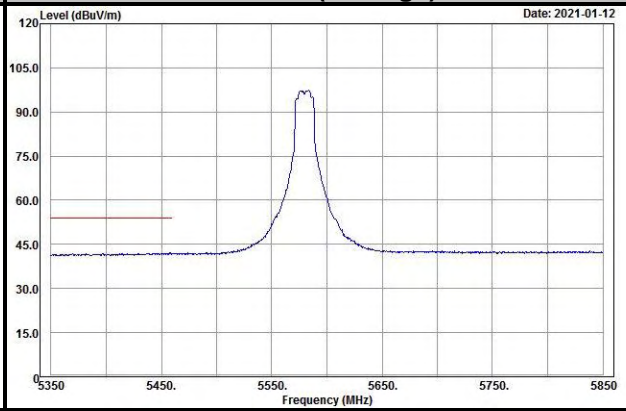

Ch 140

Horizontal (Peak)

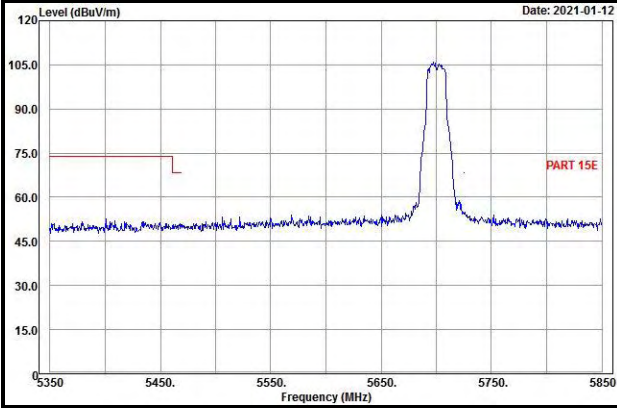

Vertical (Peak)

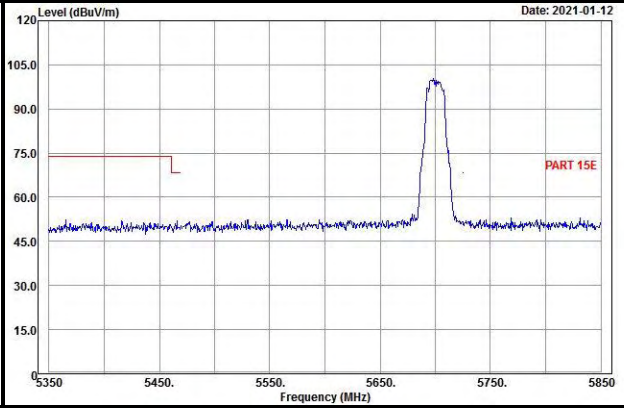

Horizontal (Average)

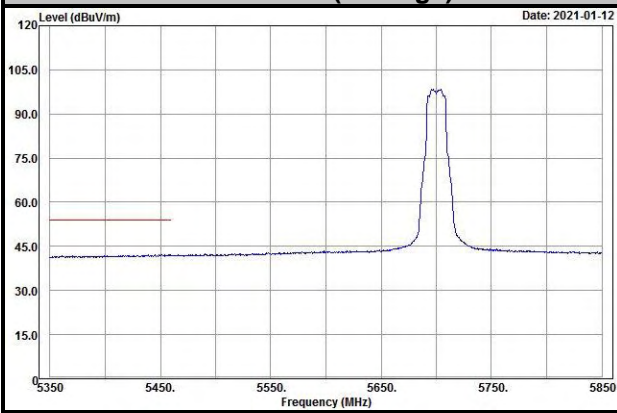

Vertical (Average)

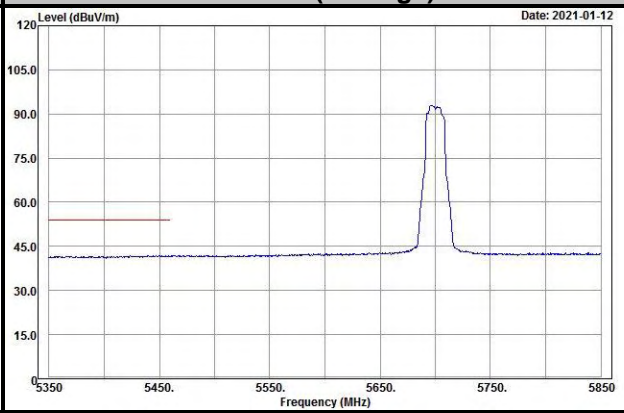

802.11ax (HE20)

Ch 36

Horizontal (Peak)

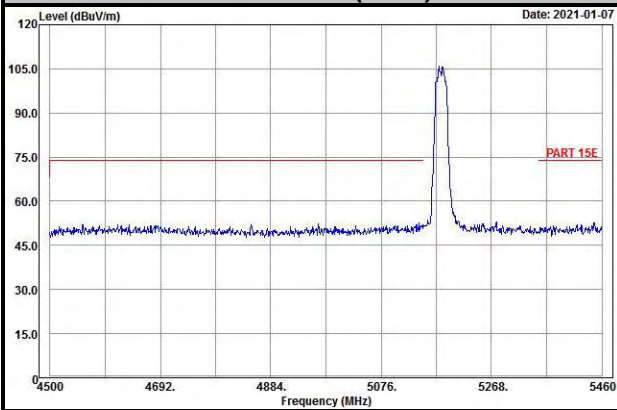

Vertical (Peak)

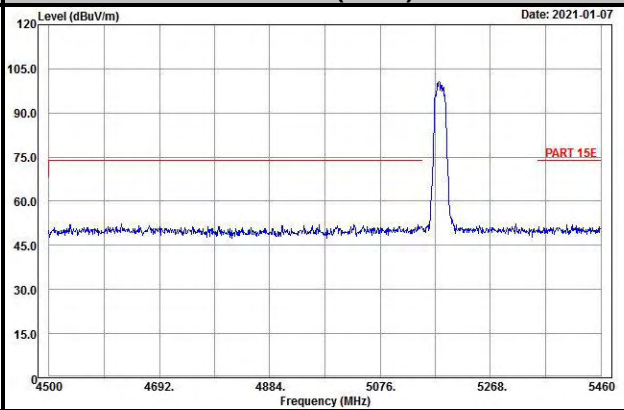

Horizontal (Average)

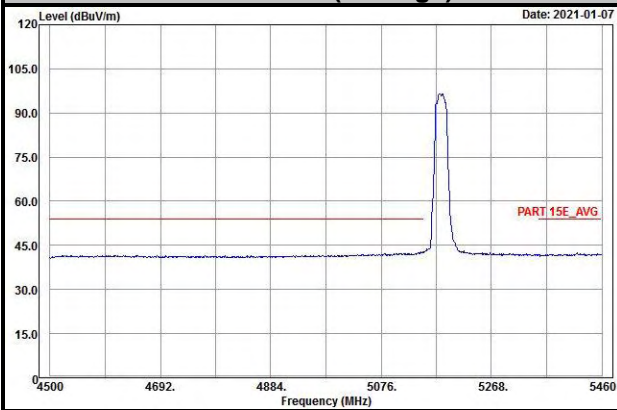

Vertical (Average)

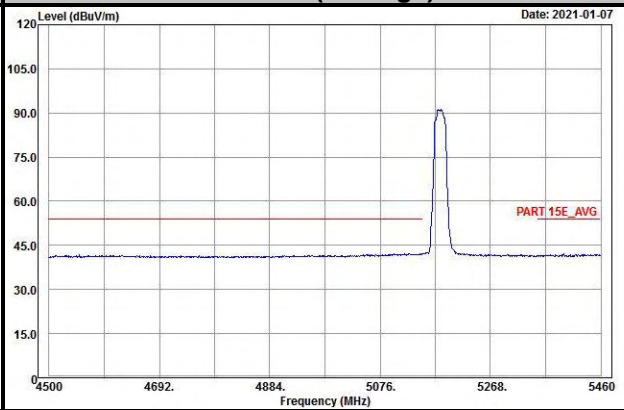

Ch 40

Horizontal (Peak)

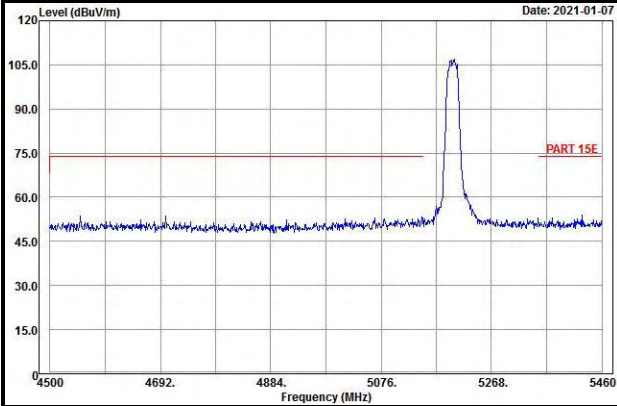

Vertical (Peak)

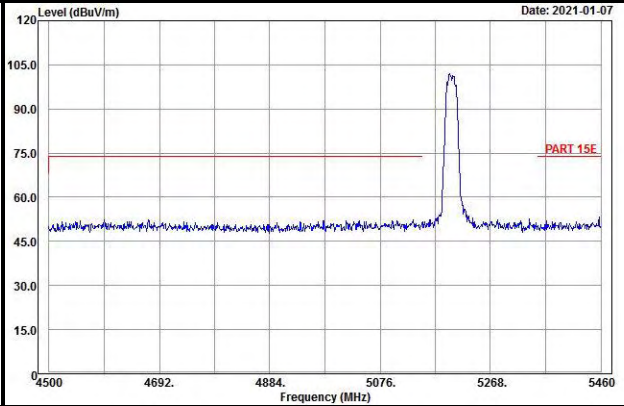

Horizontal (Average)

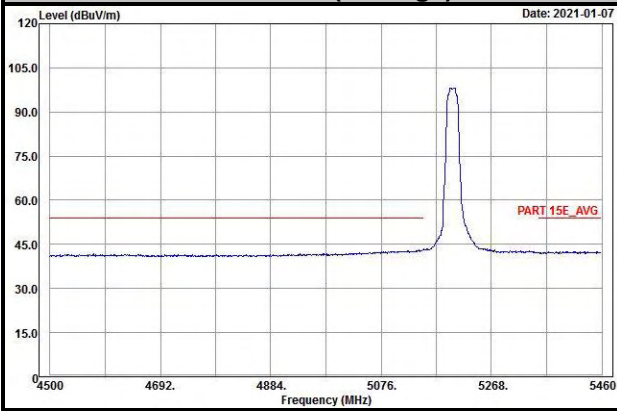

Vertical (Average)

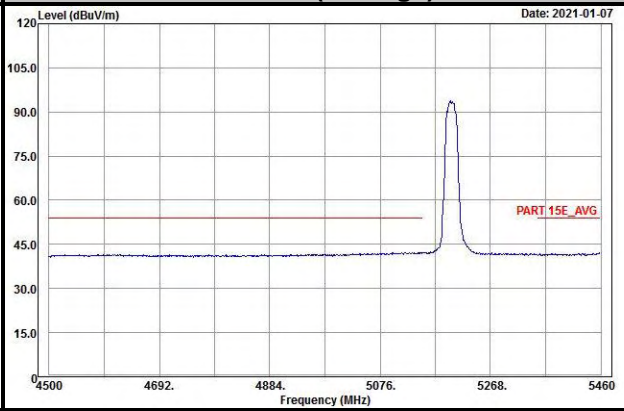

Ch 48

Horizontal (Peak)

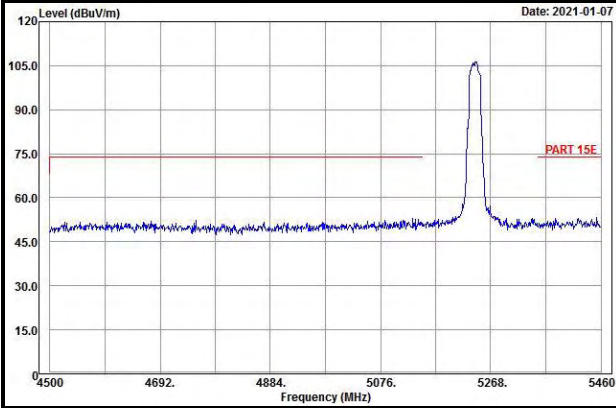

Vertical (Peak)

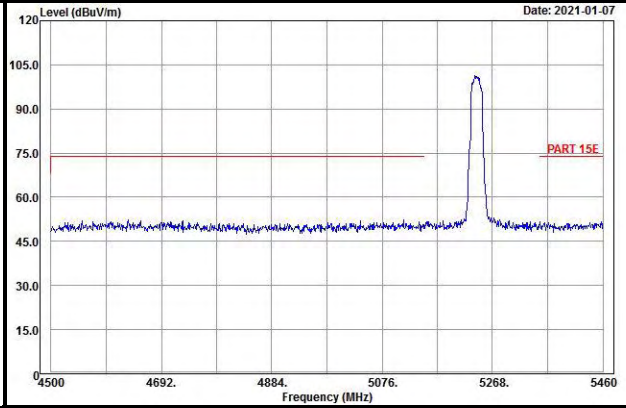

Horizontal (Average)

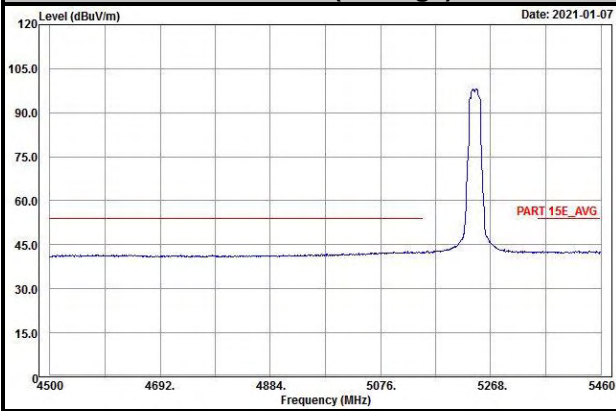

Vertical (Average)

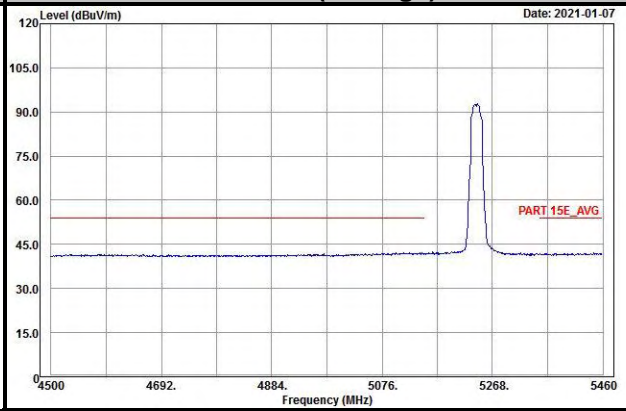

Ch 52

Horizontal (Peak)

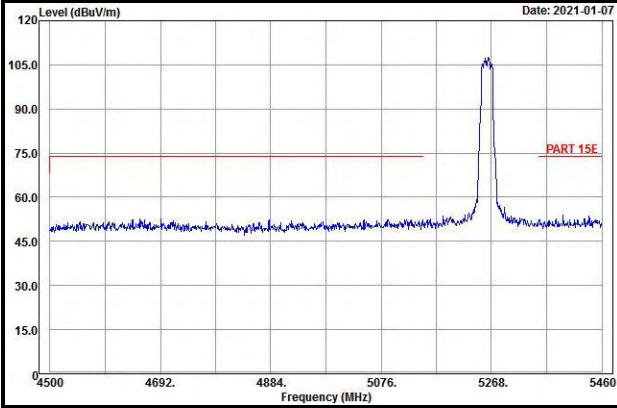

Vertical (Peak)

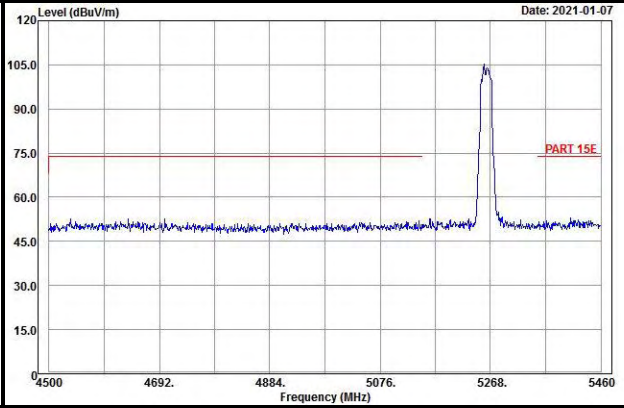

Horizontal (Average)

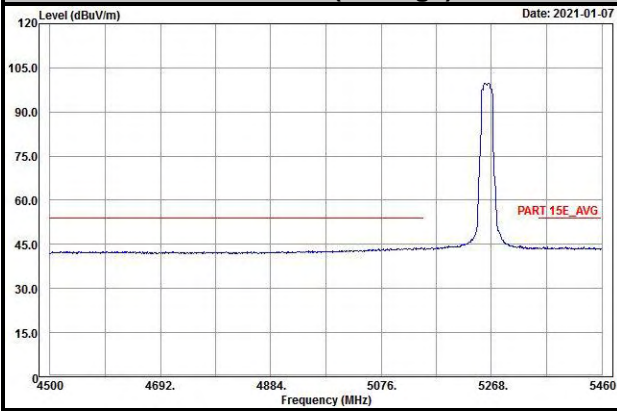

Vertical (Average)

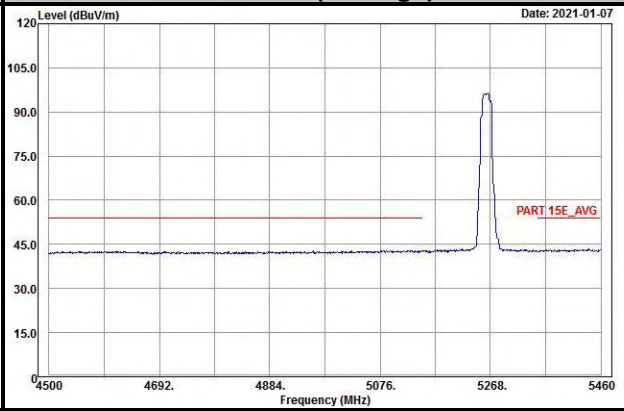

Ch 60

Horizontal (Peak)

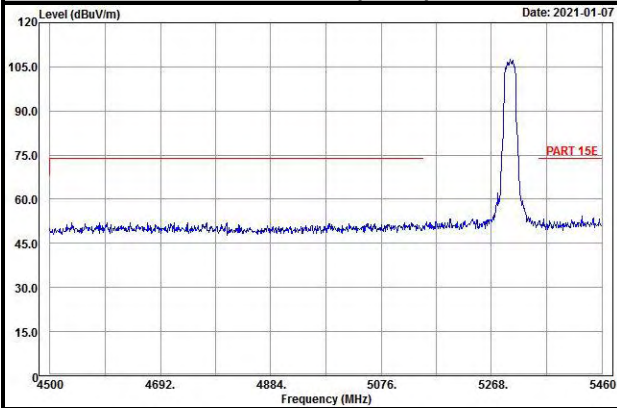

Vertical (Peak)

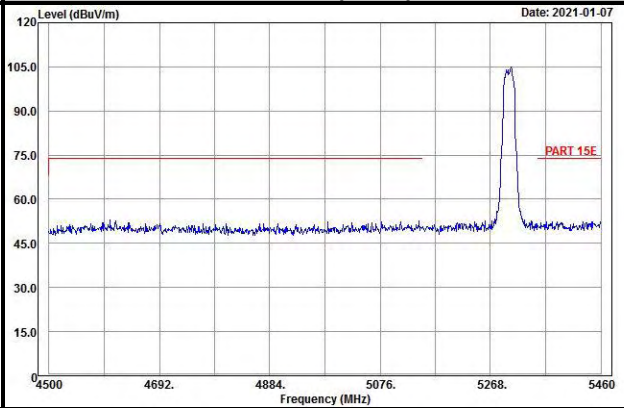

Horizontal (Average)

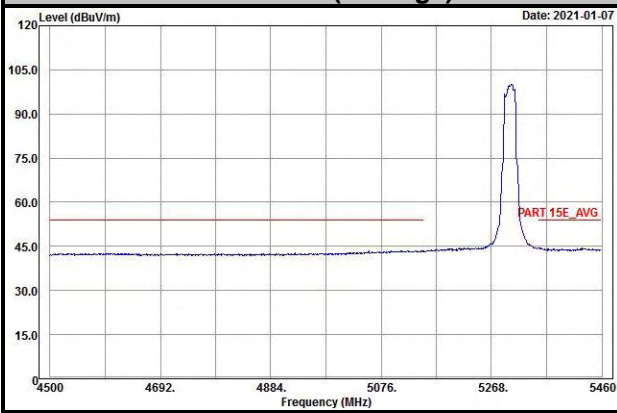

Vertical (Average)

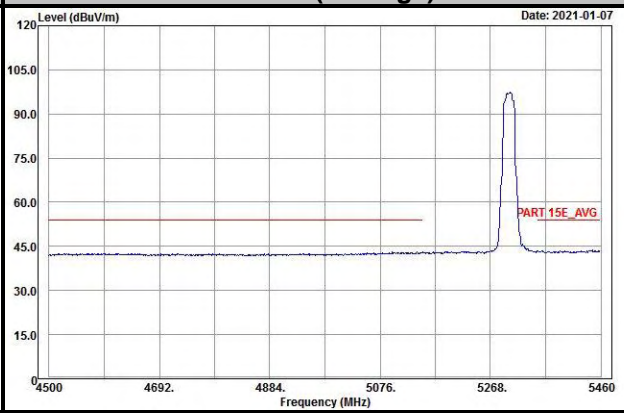

Ch 64

Horizontal (Peak)

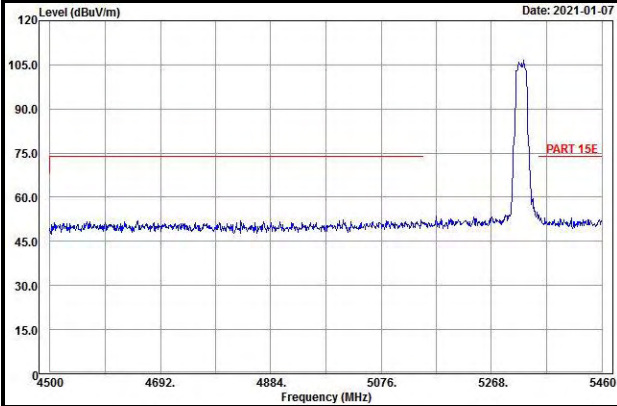

Vertical (Peak)

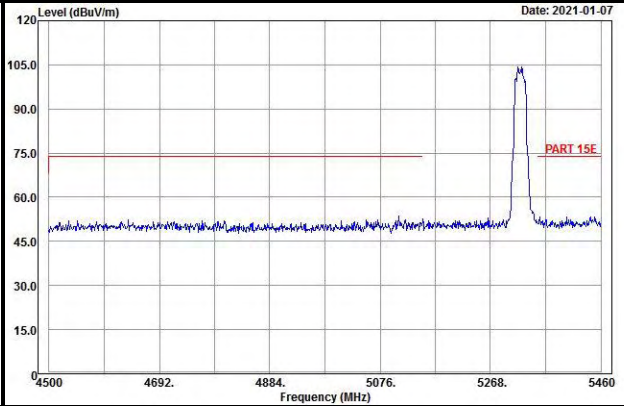

Horizontal (Average)

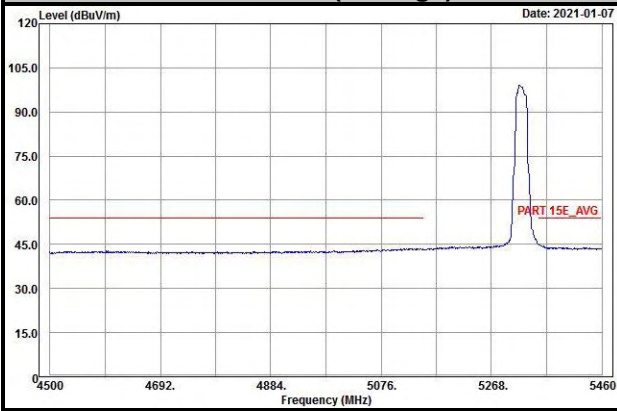

Vertical (Average)

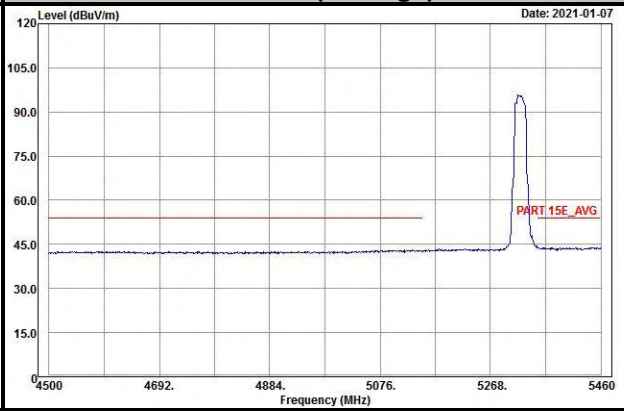

Ch 100

Horizontal (Peak)

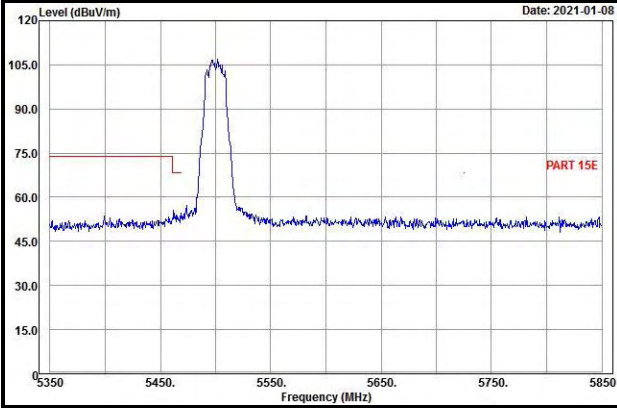

Vertical (Peak)

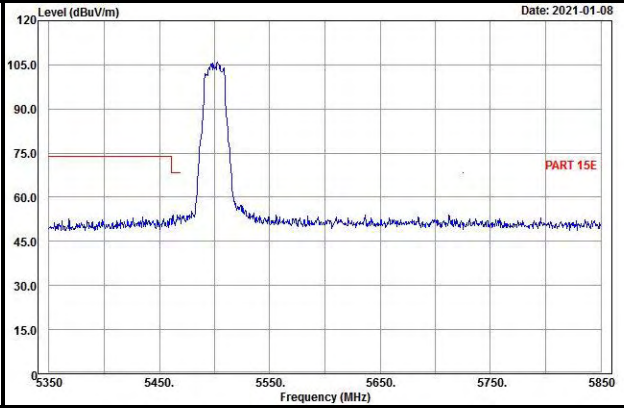

Horizontal (Average)

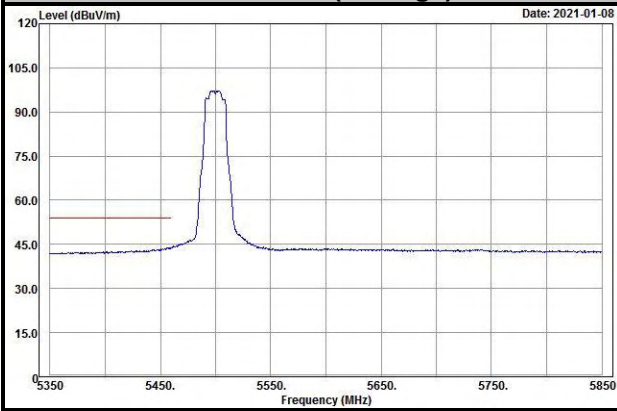

Vertical (Average)

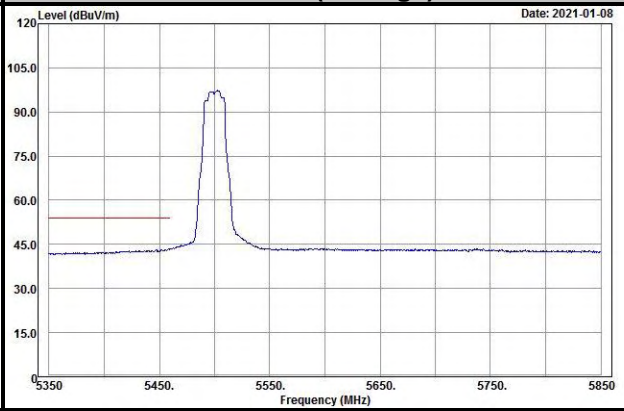

Ch 116

Horizontal (Peak)

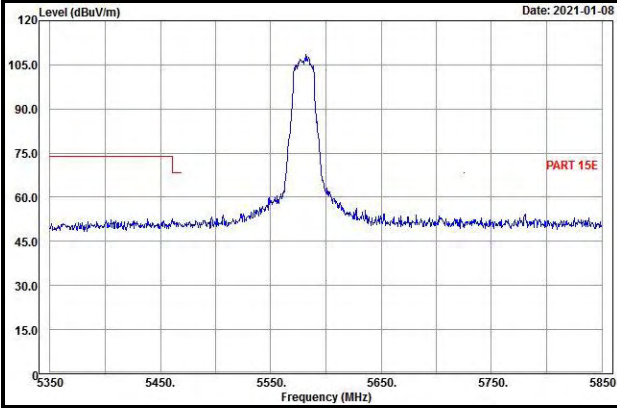

Vertical (Peak)

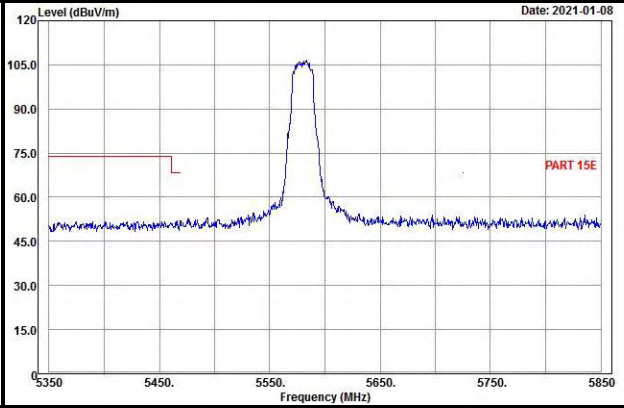

Horizontal (Average)

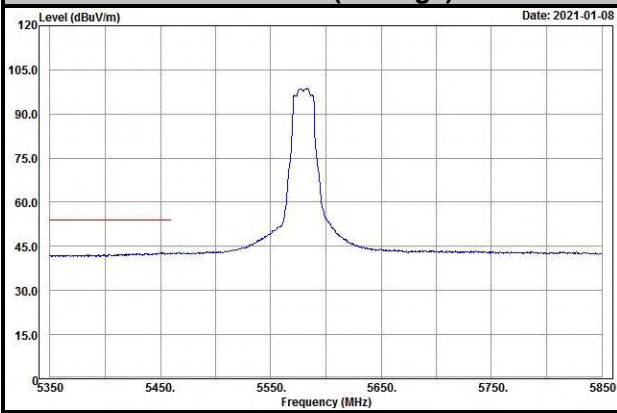

Vertical (Average)

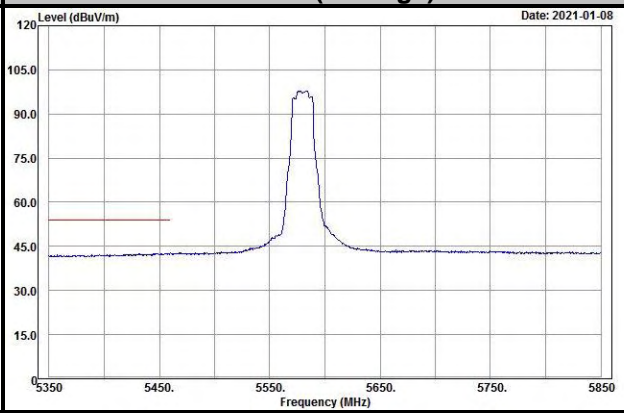

Ch 140

Horizontal (Peak)

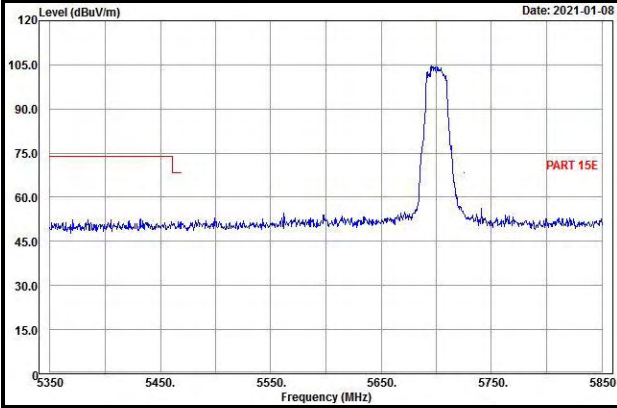

Vertical (Peak)

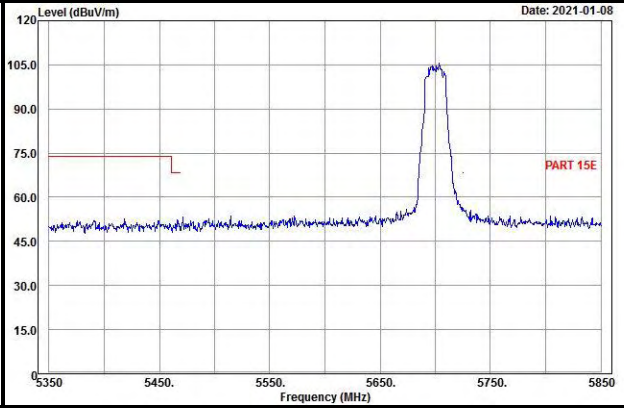

Horizontal (Average)

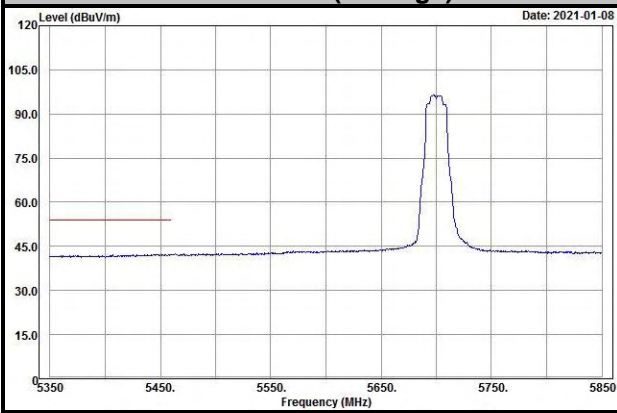

Vertical (Average)

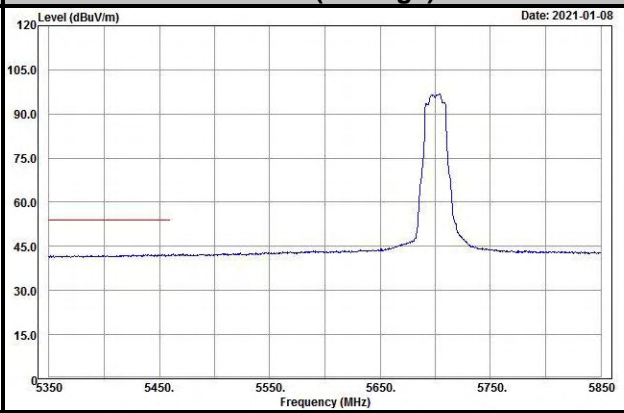

Ch 144

Horizontal (Peak)

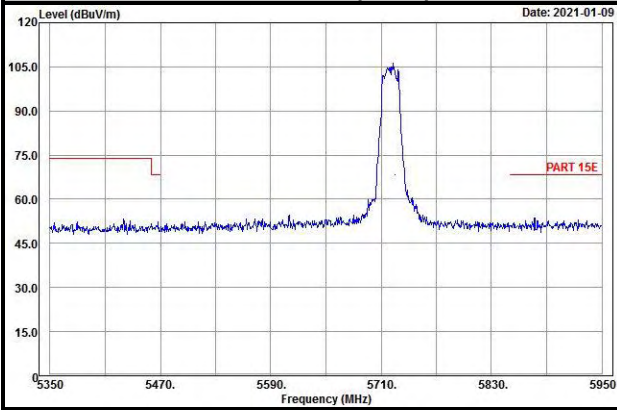

Vertical (Peak)

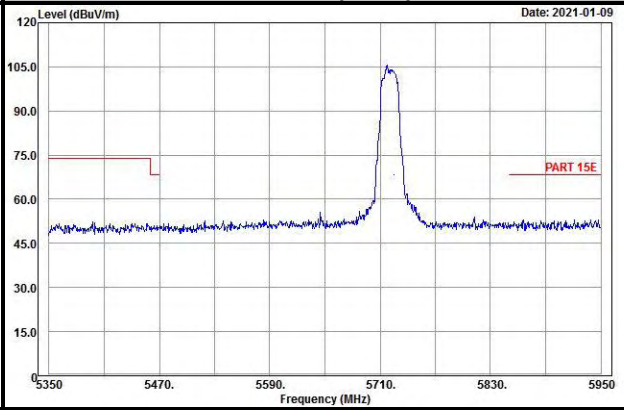

Horizontal (Average)

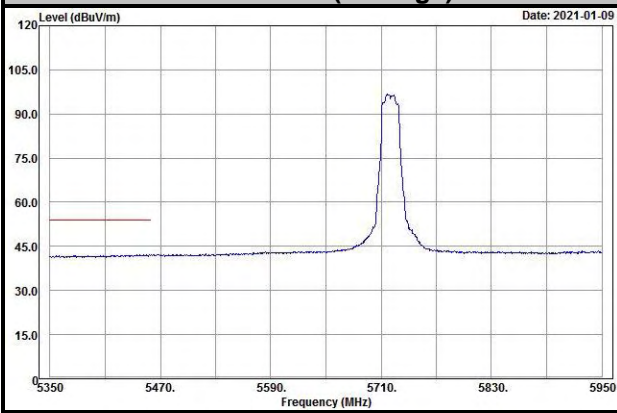

Vertical (Average)

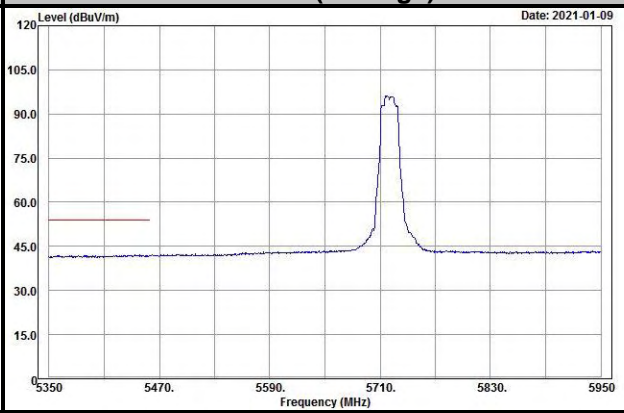

802.11ax (HE40)

Ch 38

Horizontal (Peak)

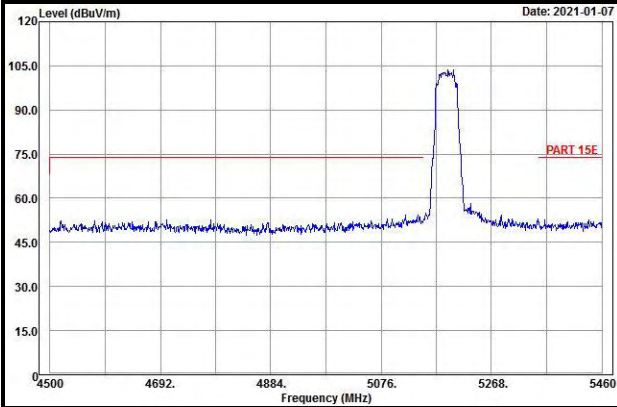

Vertical (Peak)

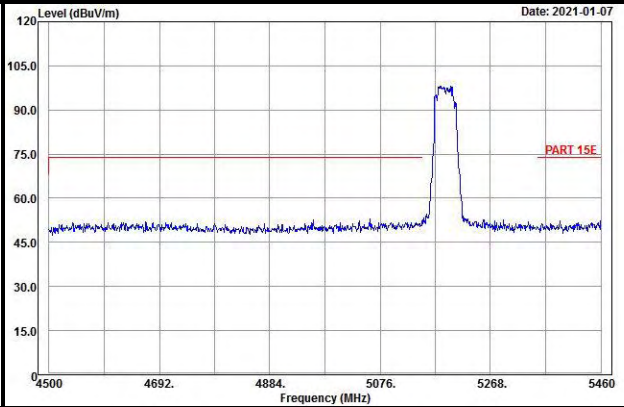

Horizontal (Average)

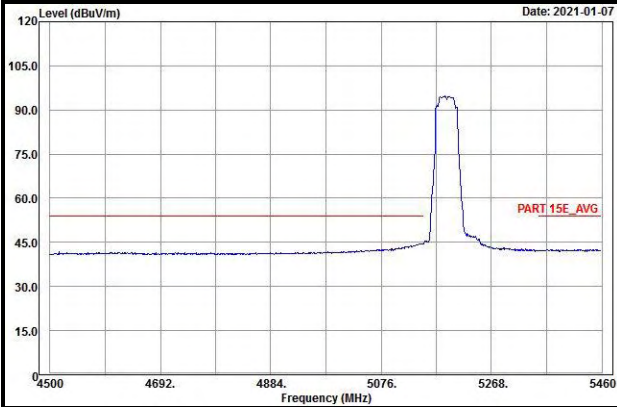

Vertical (Average)

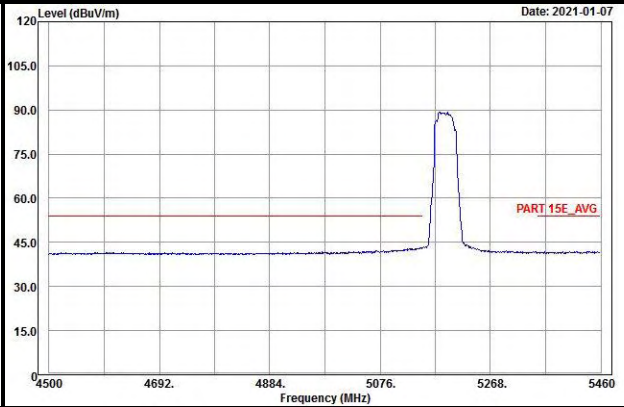

Ch 46

Horizontal (Peak)

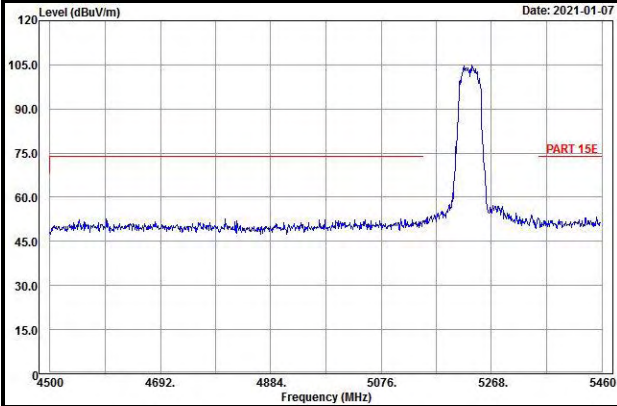

Vertical (Peak)

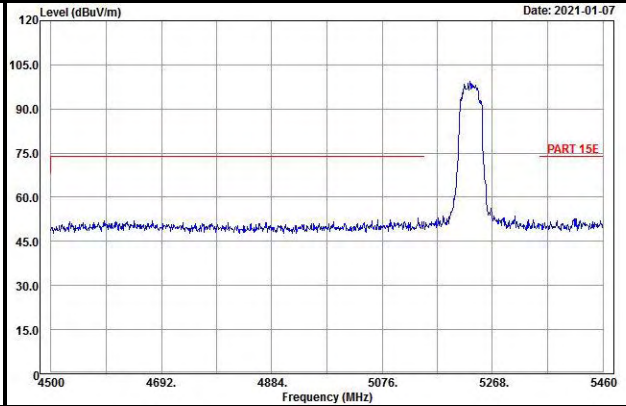

Horizontal (Average)

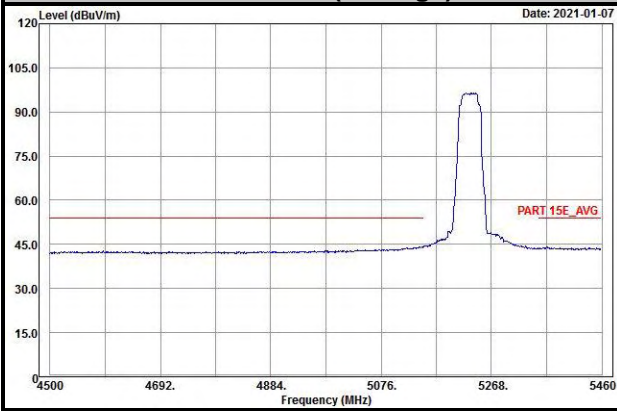

Vertical (Average)

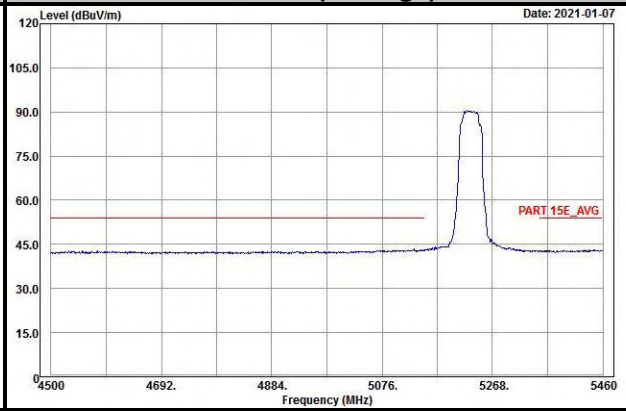

Ch 54

Horizontal (Peak)

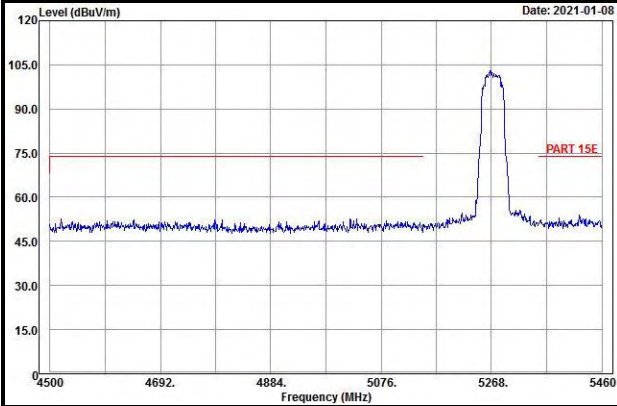

Vertical (Peak)

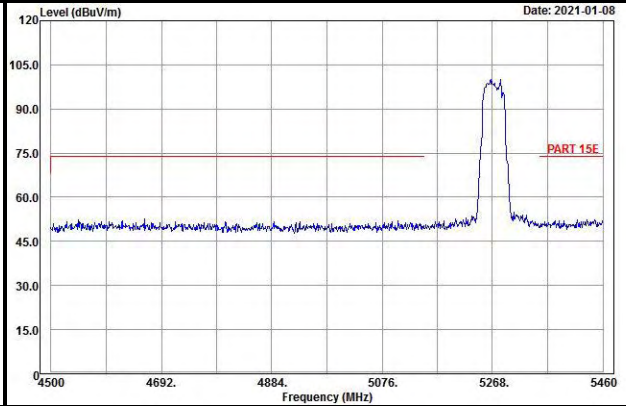

Horizontal (Average)

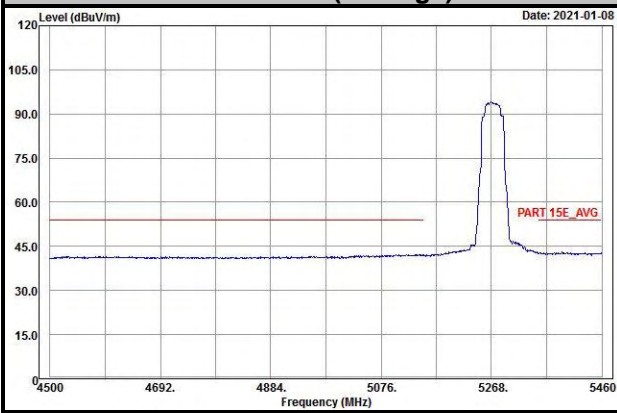

Vertical (Average)

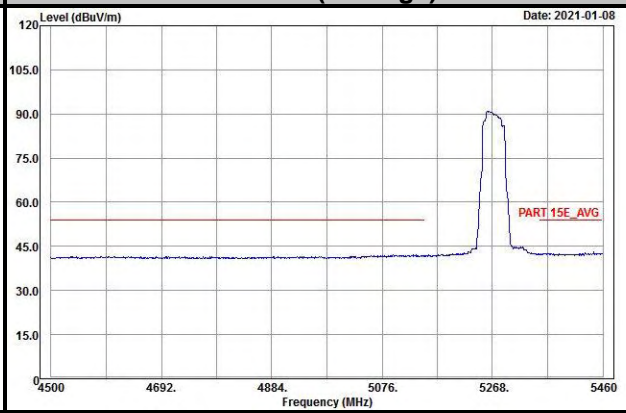

Ch 62

Horizontal (Peak)

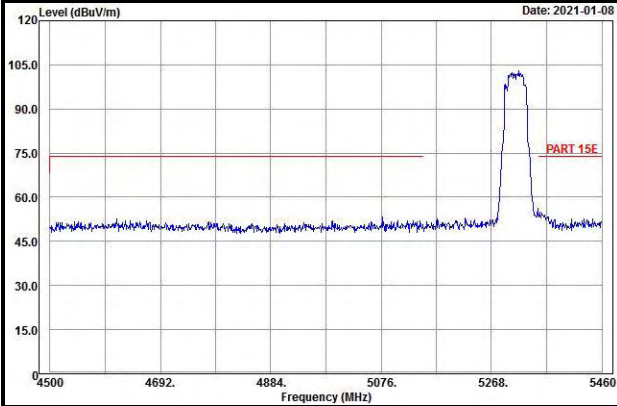

Vertical (Peak)

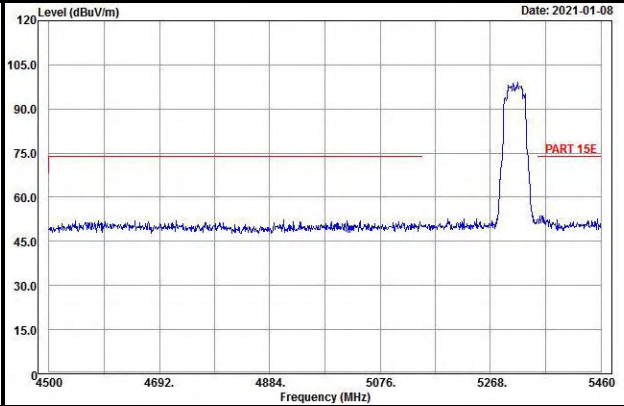

Horizontal (Average)

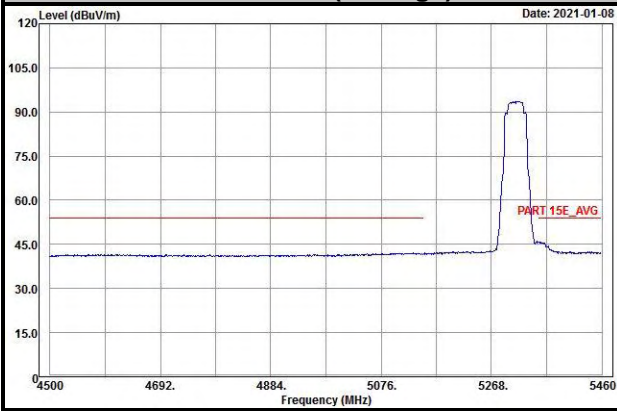

Vertical (Average)

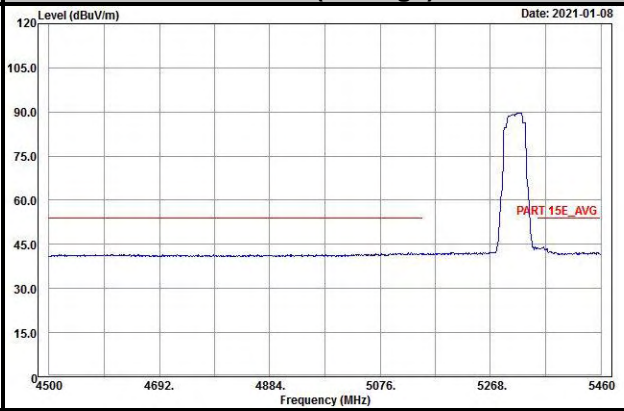

Ch 102

Horizontal (Peak)

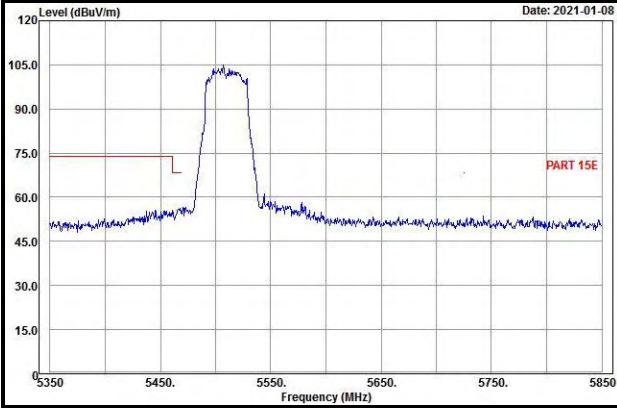

Vertical (Peak)

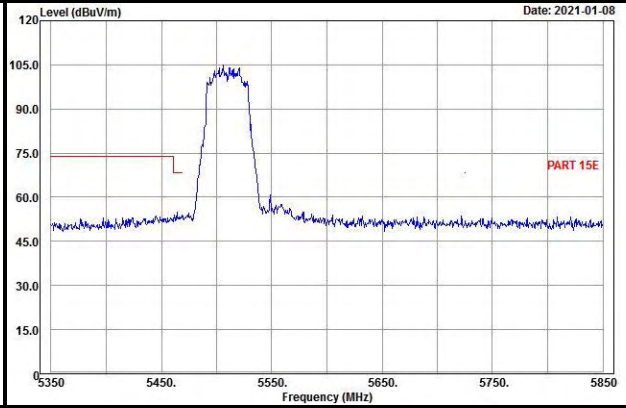

Horizontal (Average)

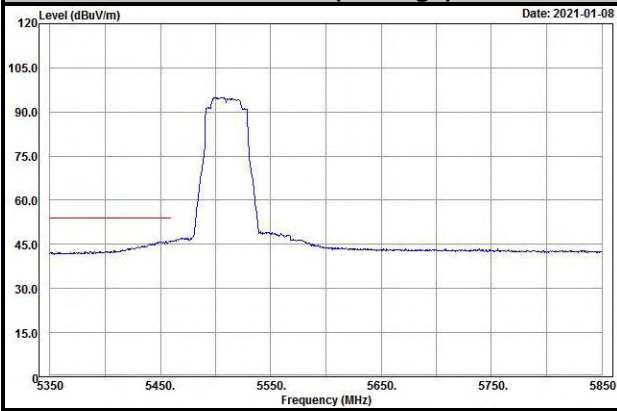

Vertical (Average)

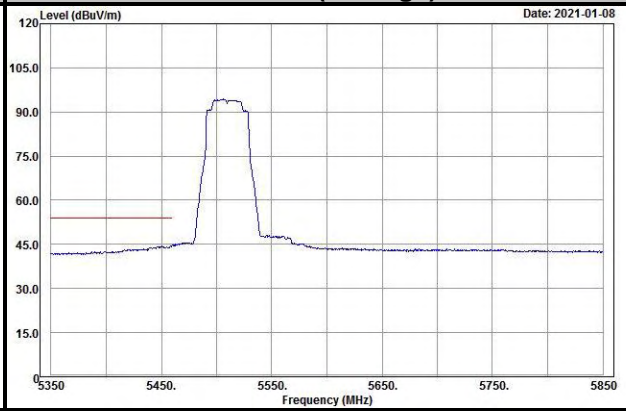

Ch 110

Horizontal (Peak)

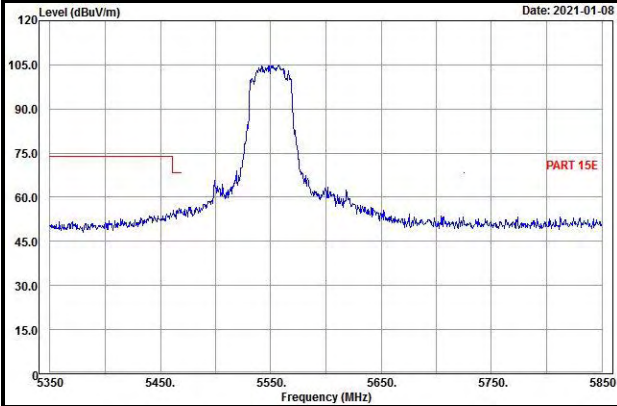

Vertical (Peak)

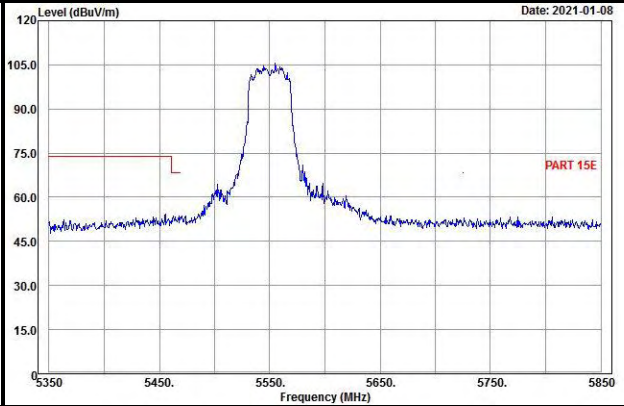

Horizontal (Average)

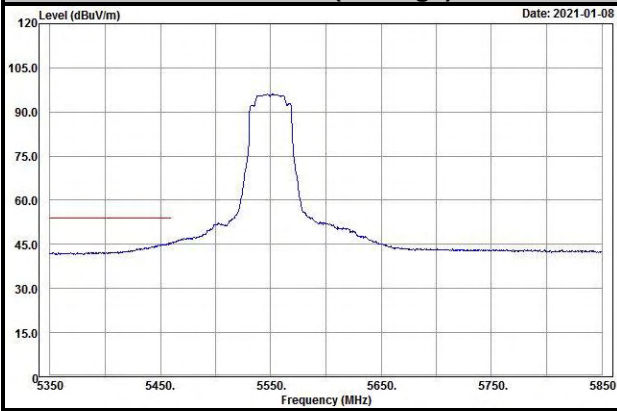

Vertical (Average)

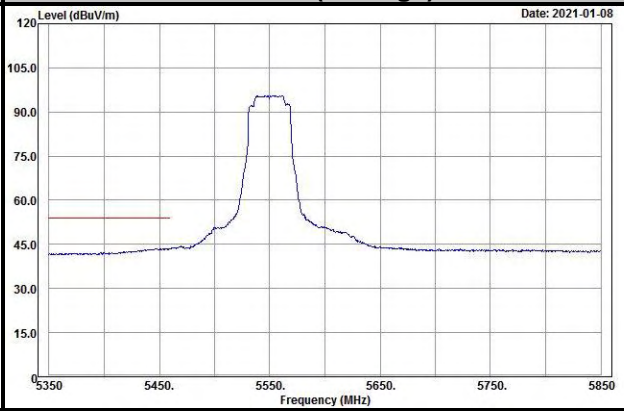

Ch 134

Horizontal (Peak)

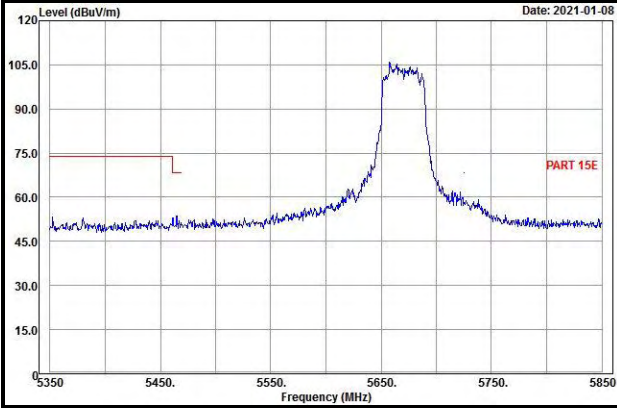

Vertical (Peak)

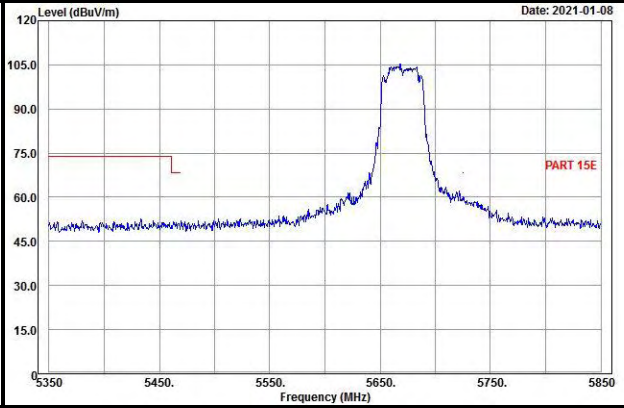

Horizontal (Average)

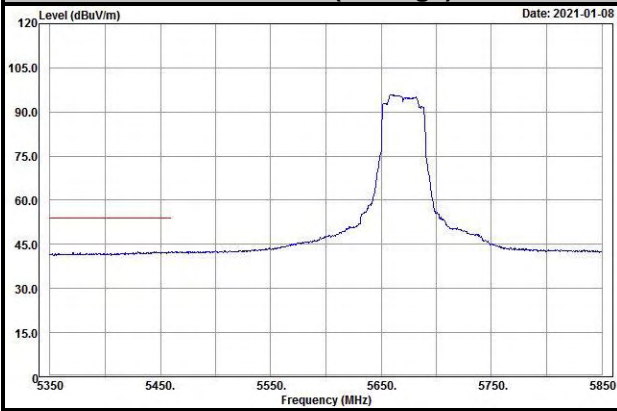

Vertical (Average)

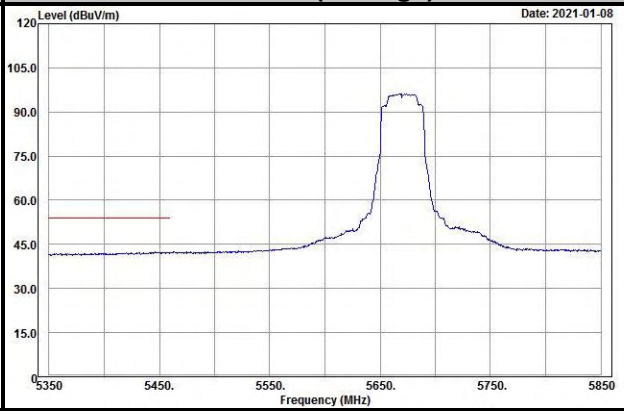

Ch 142

Horizontal (Peak)

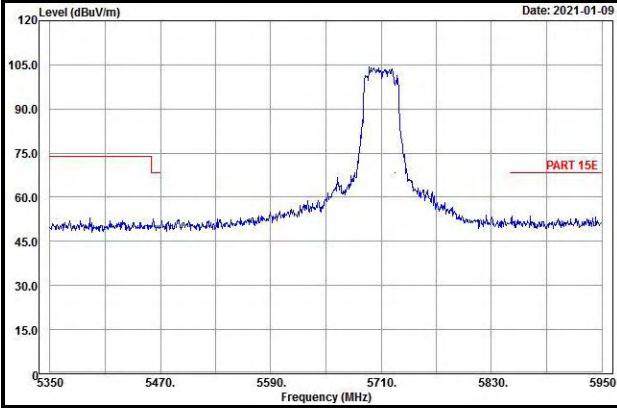

Vertical (Peak)

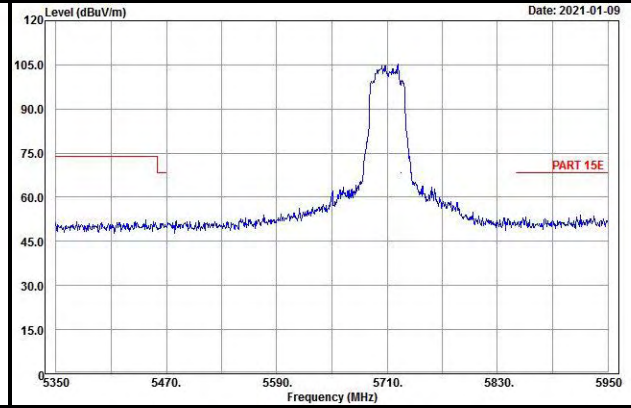

Horizontal (Average)

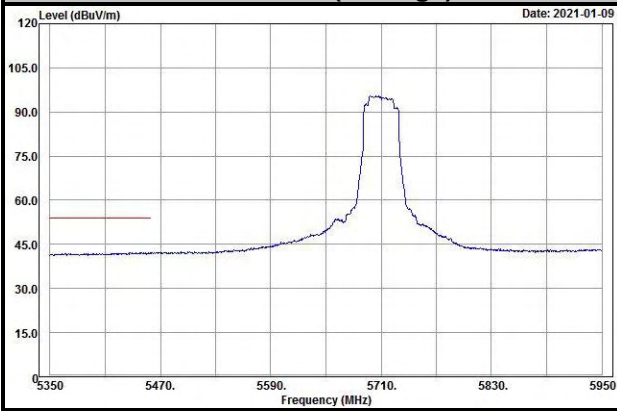

Vertical (Average)

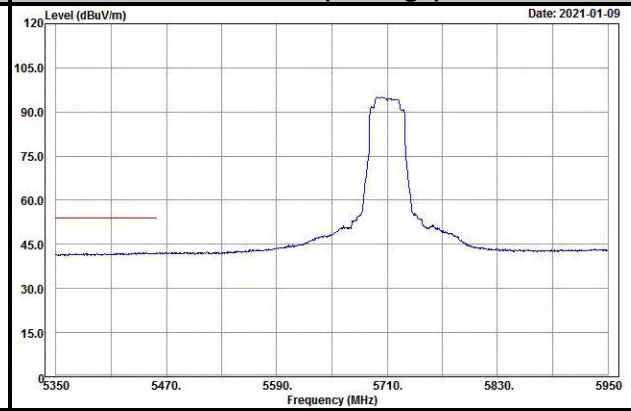

802.11ax (HE80)

Ch 42

Horizontal (Peak)

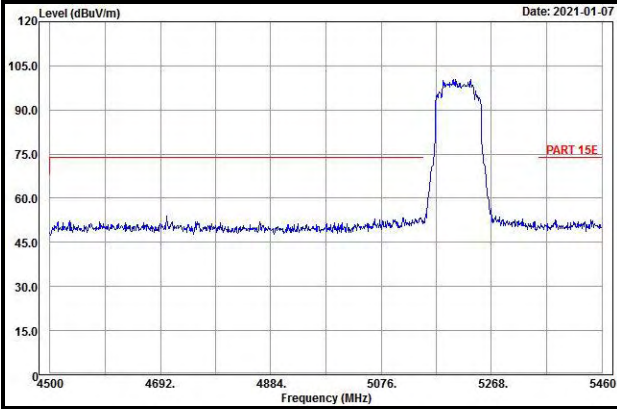

Vertical (Peak)

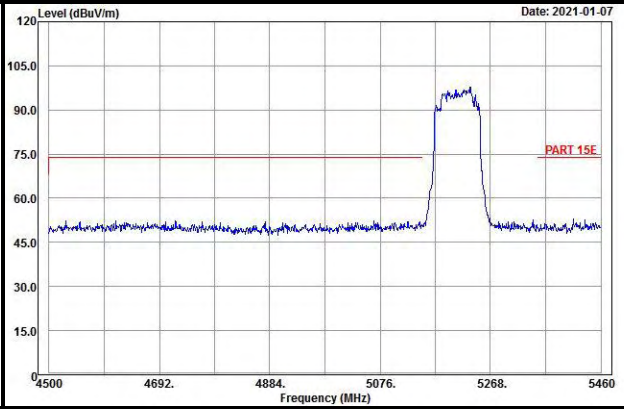

Horizontal (Average)

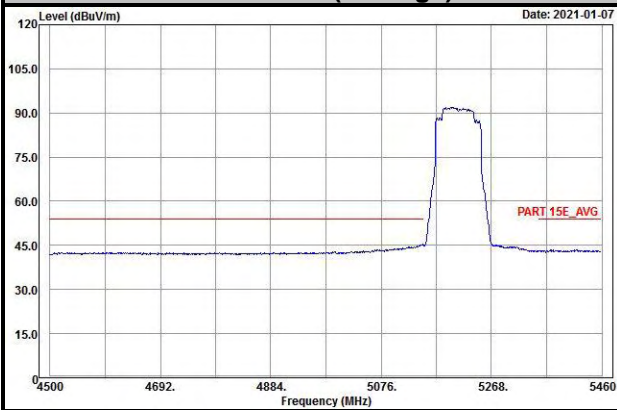

Vertical (Average)

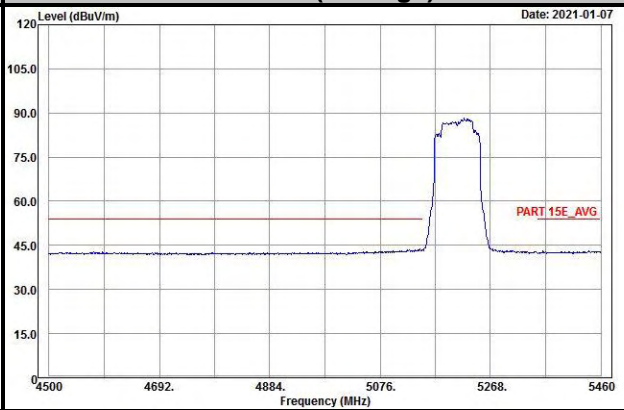

Ch 58

Horizontal (Peak)

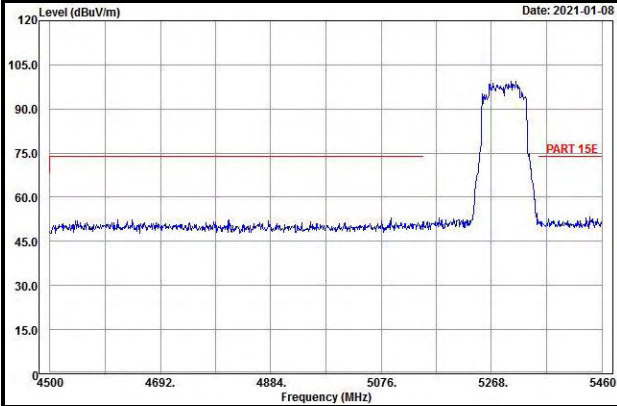

Vertical (Peak)

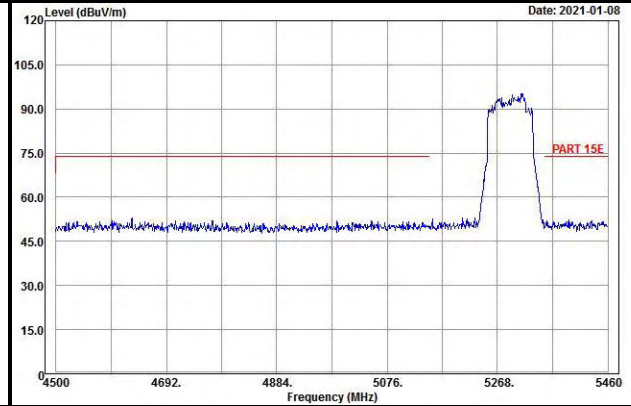

Horizontal (Average)

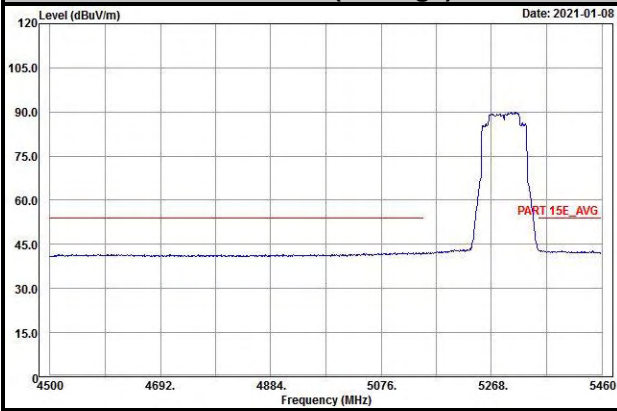

Vertical (Average)

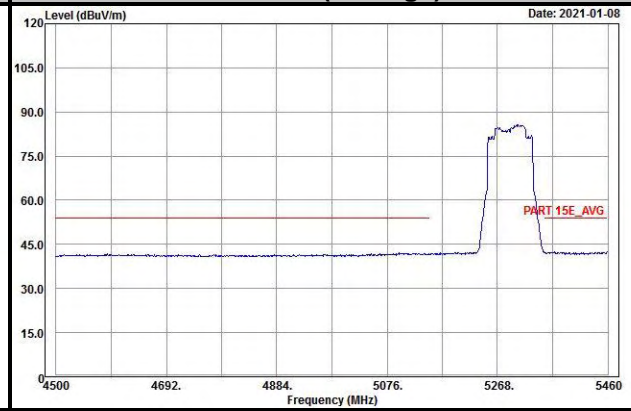

Ch 106

Horizontal (Peak)

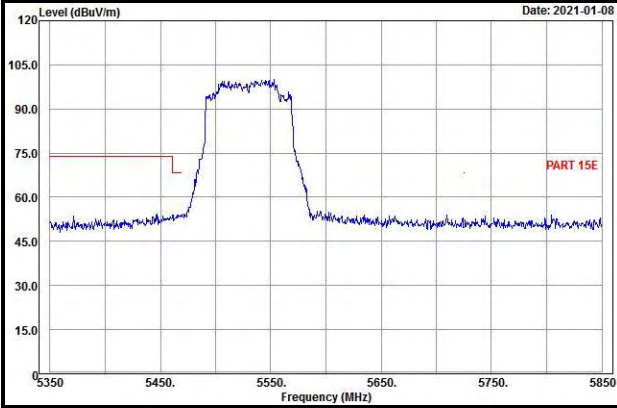

Vertical (Peak)

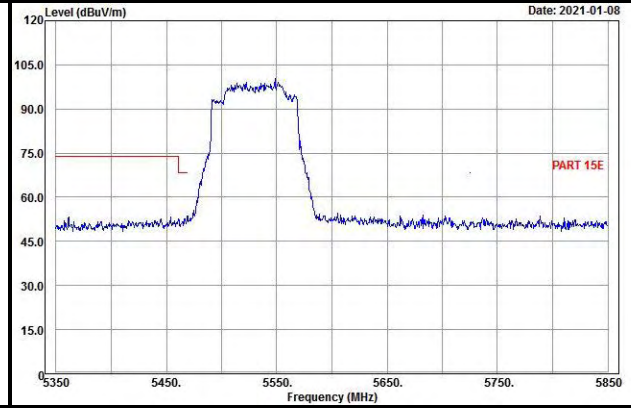

Horizontal (Average)

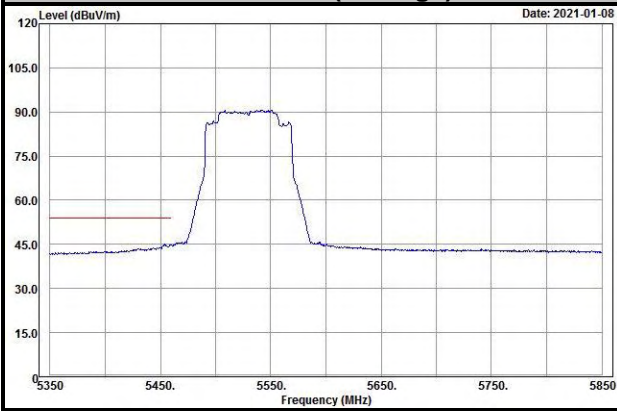

Vertical (Average)

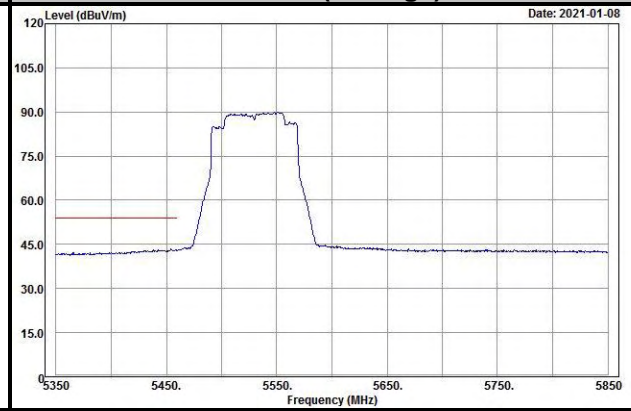

Ch 122

Horizontal (Peak)

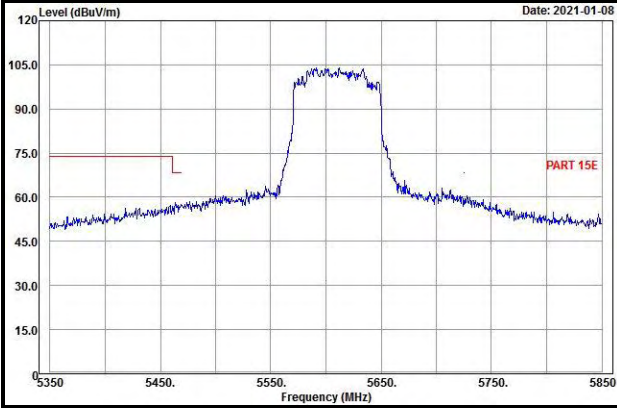

Vertical (Peak)

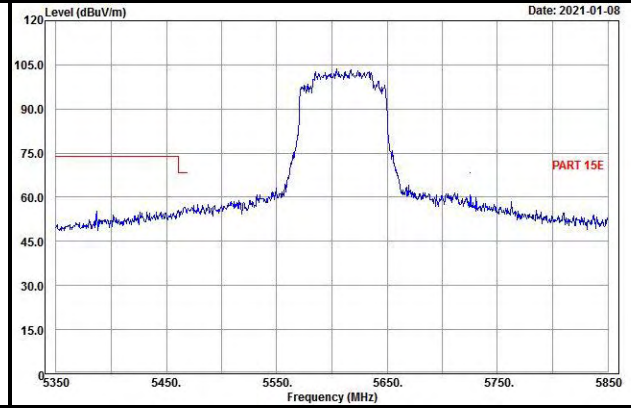

Horizontal (Average)

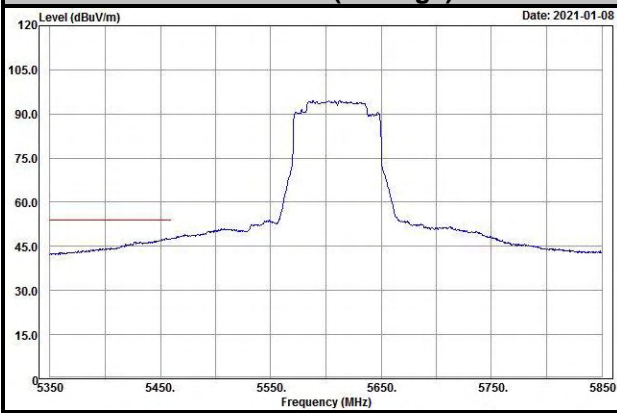

Vertical (Average)

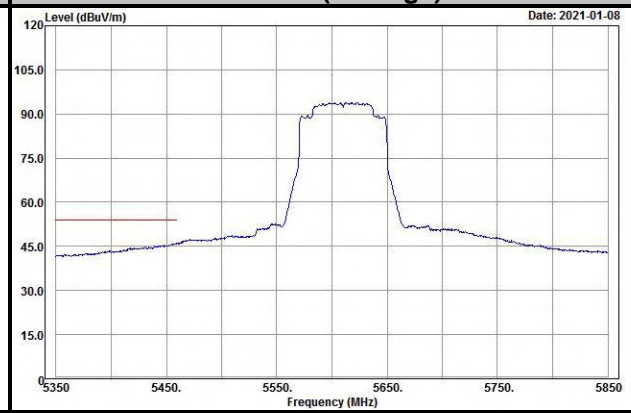

802.11ax (HE160)

Ch 50

Horizontal (Peak)

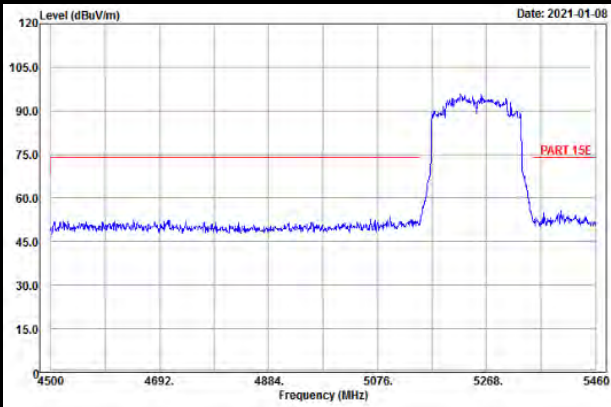

Vertical (Peak)

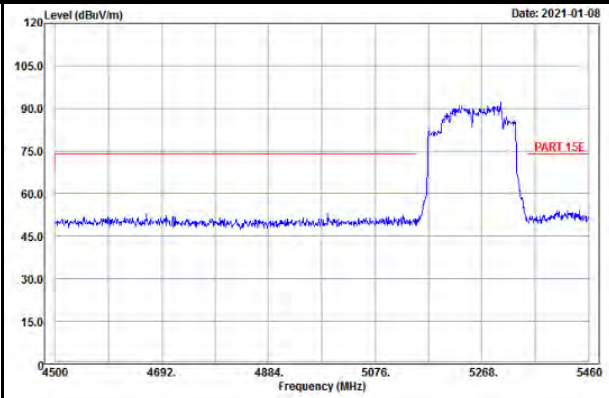

Horizontal (Average)

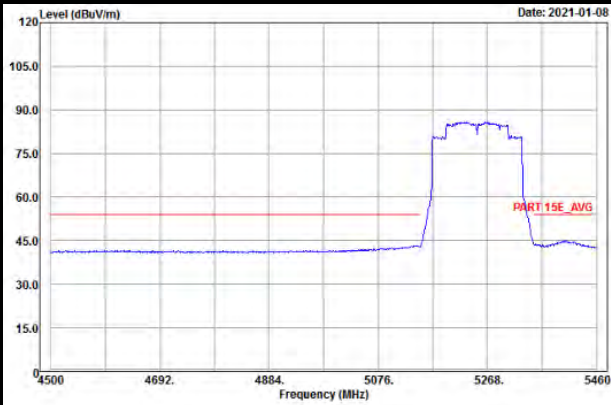

Vertical (Average)

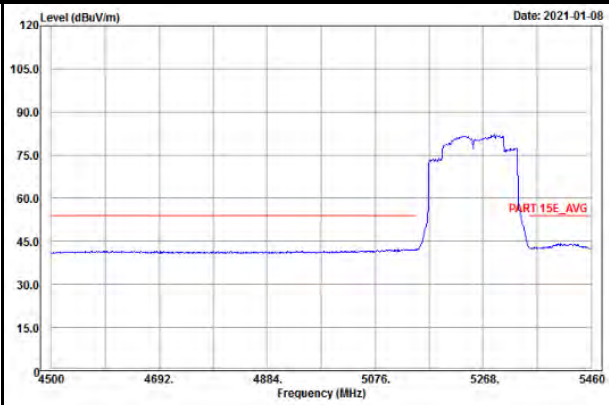

Ch 114

Horizontal (Peak)

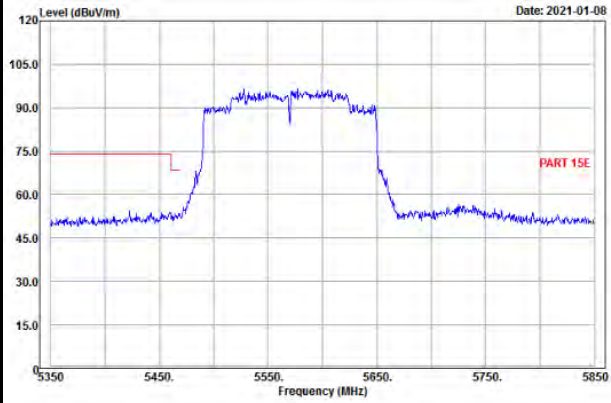

Vertical (Peak)

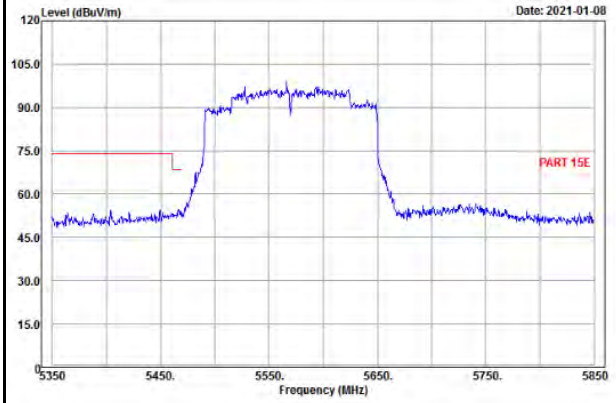

Horizontal (Average)

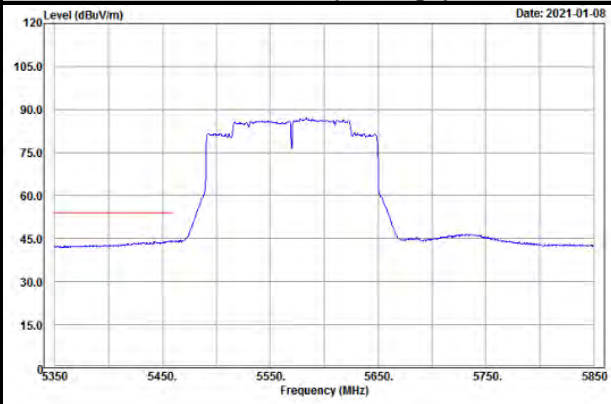

Vertical (Average)

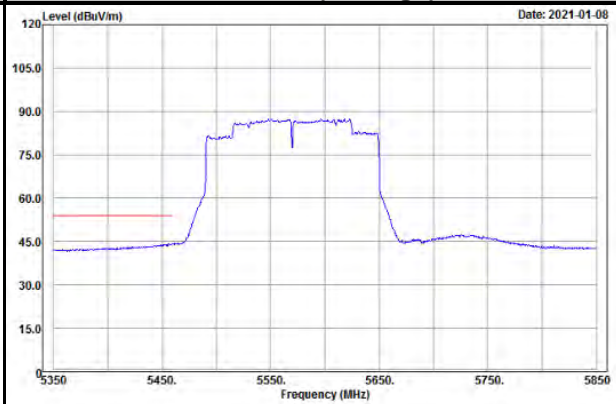

Appendix – Information of the Testing Laboratories

We, Bureau Veritas Consumer Products Services (H.K.) Ltd., Taoyuan Branch, were founded in 1988 to provide our best service in EMC, Radio, Telecom and Safety consultation. Our laboratories are FCC recognized accredited test firms and accredited according to ISO/IEC 17025.

If you have any comments, please feel free to contact us at the following:

Lin Kou EMC/RF Lab

Tel: 886-2-26052180

Fax: 886-2-26051924

Hsin Chu EMC/RF/Telecom Lab

Tel: 886-3-6668565

Fax: 886-3-6668323

Hwa Ya EMC/RF/Safety Lab

Tel: 886-3-3183232

Fax: 886-3-3270892

Email: service.adt@tw.bureauveritas.com

Web Site: www.bureauveritas-adt.com

The address and road map of all our labs can be found in our web site also.

--- END ---