

# Variant FCC SAR Test Report

**Report No.** : SA180907C14B  
**Applicant** : Getac Technology Corporation.  
**Address** : 5F., Building A, No. 209, Sec.1, Nangang Rd., Nangang Dist., Taipei City 11568, Taiwan, R.O.C.  
**Product** : Notebook  
**FCC ID** : QYL9260NG  
**Brand** : Getac  
**Model No.** : V110, V110G5  
**Standards** : FCC 47 CFR Part 2 (2.1093), IEEE C95.1:1992, IEEE Std 1528:2013  
 KDB 865664 D01 v01r04, KDB 865664 D02 v01r02, KDB 248227 D01 v02r02  
 KDB 447498 D01 v06, KDB 616217 D04 v01r02, KDB 941225 D01 v03r01,  
 KDB 941225 D05 v02r05, KDB 941225 D05A v01r02  
**Sample Received Date** : May 06, 2019  
**Date of Testing** : Jun. 19, 2019 ~ Jul. 08, 2019  
**Lab Address** : No. 47-2, 14th Ling, Chia Pau Vil., Lin Kou Dist., New Taipei City, Taiwan, R.O.C.  
**Test Location** : No. 19, Hwa Ya 2nd Rd, Wen Hwa Vil, Kwei Shan Dist., Taoyuan City 33383, Taiwan (R.O.C)

**CERTIFICATION:** The above equipment have been tested by **Bureau Veritas Consumer Products Services (H.K.) Ltd., Taoyuan Branch – Lin Kou Laboratories**, and found compliance with the requirement of the above standards. The test record, data evaluation & Equipment Under Test (EUT) configurations represented herein are true and accurate accounts of the measurements of the sample’s SAR characteristics under the conditions specified in this report. It should not be reproduced except in full, without the written approval of our laboratory. The client should not use it to claim product certification, approval, or endorsement by TAF or any government agencies.

This report is issued as a supplementary report to BV CPS report no.: SA180907C14A. Refer to Section 2 for change list.

**Prepared By :** Rona Chen  
 Rona Chen / Specialist

**Approved By :** Gordon Lin  
 Gordon Lin / Assistant Manager



FCC Accredited No.: TW0003

This report is for your exclusive use. Any copying or replication of this report to or for any other person or entity, or use of our name or trademark, is permitted only with our prior written permission. This report sets forth our findings solely with respect to the test samples identified herein. The results set forth in this report are not indicative or representative of the quality or characteristics of the lot from which a test sample was taken or any similar or identical product unless specifically and expressly noted. Our report includes all of the tests requested by you and the results thereof based upon the information that you provided to us. You have 60 days from date of issuance of this report to notify us of any material error or omission caused by our negligence, provided, however, that such notice shall be in writing and shall specifically address the issue you wish to raise. A failure to raise such issue within the prescribed time shall constitute your unqualified acceptance of the completeness of this report, the tests conducted and the correctness of the report contents. Unless specific mention, the uncertainty of measurement has been explicitly taken into account to declare the compliance or non-compliance to the specification.

## Table of Contents

<b>Release Control Record .....</b>	<b>3</b>
<b>1. Summary of Maximum SAR Value .....</b>	<b>4</b>
<b>2. Description of Equipment Under Test .....</b>	<b>5</b>
<b>3. SAR Measurement System .....</b>	<b>7</b>
3.1 Definition of Specific Absorption Rate (SAR) .....	7
3.2 SPEAG DASY52 System .....	7
3.2.1 Robot.....	8
3.2.2 Probes.....	9
3.2.3 Data Acquisition Electronics (DAE) .....	9
3.2.4 Phantoms .....	10
3.2.5 Device Holder.....	11
3.2.6 System Validation Dipoles.....	11
3.2.7 Tissue Simulating Liquids.....	12
3.3 SAR System Verification .....	14
3.4 SAR Measurement Procedure .....	15
3.4.1 Area & Zoom Scan Procedure .....	15
3.4.2 Volume Scan Procedure.....	15
3.4.3 Power Drift Monitoring.....	16
3.4.4 Spatial Peak SAR Evaluation .....	16
3.4.5 SAR Averaged Methods .....	16
<b>4. SAR Measurement Evaluation .....</b>	<b>17</b>
4.1 EUT Configuration and Setting.....	17
4.2 EUT Testing Position .....	29
4.2.1 Body Exposure Conditions .....	29
4.2.2 SAR Test Exclusion Evaluations .....	31
4.3 Tissue Verification .....	33
4.4 System Validation.....	33
4.5 System Verification.....	34
4.6 Maximum Output Power.....	35
4.6.1 Maximum Target Conducted Power .....	35
4.6.2 Measured Conducted Power Result.....	37
4.7 SAR Testing Results .....	50
4.7.1 SAR Test Reduction Considerations .....	50
4.7.2 SAR Results for Body Exposure Condition (Test Separation Distance is 0 mm) .....	54
4.7.3 SAR Measurement Variability.....	57
4.7.4 Simultaneous Multi-band Transmission Evaluation .....	58
<b>5. Calibration of Test Equipment.....</b>	<b>66</b>
<b>6. Measurement Uncertainty.....</b>	<b>67</b>
<b>7. Information on the Testing Laboratories.....</b>	<b>69</b>

- Appendix A. SAR Plots of System Verification**
- Appendix B. SAR Plots of SAR Measurement**
- Appendix C. Calibration Certificate for Probe and Dipole**
- Appendix D. Photographs of EUT and Setup**



**1. Summary of Maximum SAR Value**

Equipment Class	Mode	Highest SAR-1g Body Tested at 0 mm (W/kg)	
		Laptop PC Mode	Tablet PC Mode
PCB	WCDMA II	N/A	1.17
	WCDMA IV	N/A	1.08
	WCDMA V	N/A	0.72
	LTE 2	N/A	1.10
	LTE 7	N/A	0.78
	LTE 12	N/A	0.84
	LTE 13	N/A	0.98
	LTE 14	N/A	0.89
	LTE 26 / 5	N/A	0.80
	LTE 41	N/A	0.33
	LTE 66 / 4	N/A	1.19
DTS	2.4G WLAN	N/A	0.60
NII	5.3G WLAN	N/A	1.36
	5.6G WLAN	N/A	1.19
	5.8G WLAN	N/A	1.09
DSS	Bluetooth	N/A	0.04
DXX	NFC	N/A	N/A

Highest Simultaneous Transmission SAR	Highest SAR-1g Body Tested at 0 mm (W/kg)	
	Laptop PC Mode	Tablet PC Mode
	N/A	1.59

**Note:**

1. The SAR criteria (**Head & Body: SAR-1g 1.6 W/kg, and Extremity: SAR-10g 4.0 W/kg**) for general population / uncontrolled exposure is specified in FCC 47 CFR part 2 (2.1093) and ANSI/IEEE C95.1-1992.
2. This device supports both LTE band 66 and band 4. The frequency span of LTE band 66 can completely cover LTE band 4, and they has the same tune-up power. SAR was tested for LTE band 66 only.
3. This device supports both LTE band 26 and band 5. The frequency span of LTE band 26 can completely cover LTE band 5, and they has the same tune-up power. SAR was tested for LTE band 26 only.

## 2. Description of Equipment Under Test

<b>EUT Type</b>	Notebook
<b>FCC ID</b>	QYL9260NG
<b>Brand Name</b>	Getac
<b>Model Name</b>	V110, V110G5
<b>Tx Frequency Bands (Unit: MHz)</b>	WCDMA Band II : 1852.4 ~ 1907.6 WCDMA Band IV : 1712.4 ~ 1752.6 WCDMA Band V : 826.4 ~ 846.6 LTE Band 2 : 1850.7 ~ 1909.3 (BW: 1.4M, 3M, 5M, 10M, 15M, 20M) LTE Band 4 : 1710.7 ~ 1754.3 (BW: 1.4M, 3M, 5M, 10M, 15M, 20M) LTE Band 5 : 824.7 ~ 848.3 (BW: 1.4M, 3M, 5M, 10M) LTE Band 7 : 2502.5 ~ 2567.5 (BW: 5M, 10M, 15M, 20M) LTE Band 12 : 699.7 ~ 715.3 (BW: 1.4M, 3M, 5M, 10M) LTE Band 13 : 779.5 ~ 784.5 (BW: 5M, 10M) LTE Band 14 : 790.5 ~ 795.5 (BW: 5M, 10M) LTE Band 26 : 814.7 ~ 848.3 (BW: 1.4M, 3M, 5M, 10M, 15M) LTE Band 41 : 2498.5 ~ 2687.5 (BW: 5M, 10M, 15M, 20M) LTE Band 66 : 1710~178- MHz (BW: 5M, 10M, 15M, 20M) WLAN : 2412 ~ 2472, 5180 ~ 5250, 5260 ~ 5320, 5500 ~ 5700, 5745 ~ 5825 Bluetooth : 2402 ~ 2480 NFC : 13.56
<b>Uplink Modulations</b>	WCDMA : QPSK LTE : QPSK, 16QAM, 64QAM 802.11b : DSSS 802.11a/g/n/ac : OFDM Bluetooth : GFSK, $\pi/4$ -DQPSK, 8-DPSK NFC : ASK
<b>Maximum Tune-up Conducted Power (Unit: dBm)</b>	Please refer to section 4.6.1 of this report
<b>Antenna Type</b>	Fixed Internal Antenna
<b>EUT Stage</b>	Identical Prototype

**Note:**

- This report is issued as a supplementary report to BV CPS report no.: SA180907C14A. The difference compared with original report is adding new SKU for host (Brand: Getac, Model: V110G5) with new WLAN module (Brand: Intel, Model: 9260NGW) and components as below. Therefore, the EUT was verified on WWAN worse case and retested on WLAN, except tested WCDMA IV and LTE Band 66 completely.

Component	EUT (Model: V110)			EUT (Model: V110G5)		
	Brand	Model	Spec.	Brand	Model	Spec.
Battery	Getac Technology Corp.	BP3S1P2100-S	11.1 Vdc, 2100 mAh	Getac Technology Corp.	BP3S1P2100-S	11.1 Vdc, 2100 mAh
WWAN Module	Sierra Wireless, Inc.	EM7511	--	Sierra Wireless, Inc.	EM7511	--
WiFi & BT Module	Intel	8265NGW	--	Intel	9260NGW	--
	Intel	9260NGW	--			
LCD Panel	New IPS KD	KD116N11-30NP-A9	11.6"	AUO	B116XAN05.0	11.6"
				New IPS KD	KD116N11-30NP-A9	11.6"
CPU	Intel	Kabylake	i7-7600U VPRO	Intel	Kabylake	I5-8265U (Non Vpro)
				Intel	Kabylake	I7--8565U (Non Vpro)
DDR	Transcend	N/A	8GB *2	Kingston	N/A	16GB (8GB+8GB)
				Kingston	N/A	32GB (16GB+16GB)
				N/A	N/A	16GB*1
SSD	Lite-on	N/A	256GB *1	Lite-on	N/A	256GB *1
				Lite-on	N/A	512GB *1
				Sandisk	N/A	1TB *1
RFID module	NXP	PN-7462	--	NXP	PN-7462	--
Digitizer module	Microchip	PIC32MX270	--	Microchip	PIC32MX270	--
GPS	GlobalSat	MC1010	--	GlobalSat	MC1010	--

# FCC SAR Test Report

2. The EUT is authorized for use in specific End-product. Please refer to below for more details.

Product	Brand	Model	Difference
Notebook	Getac	V110	All models are electrically identical, different model names are for marketing purpose.
		V110G5 (Tested model)	

3. The configurations of EUT (Brand: Getac, Model: V110G5) are listed as below.

Component	Brand	Model	Spec.	Configurations		
				SKU 1	SKU 2	SKU 3
CPU	Intel	Kabylake	i5-8265U (Non Vpro)	V		
	Intel	Kabylake	i7-8565U (Non Vpro)		V	
	Intel	Kabylake	i5-8265U (Non Vpro)			V
DDR	Kingston	N/A	16GB (8GB+8GB)	V		
	Kingston	N/A	32GB (16GB+16GB)		V	
	Kingston	N/A	16GB			V
SSD	Lite-on	N/A	256GB	V		
	Lite-on	N/A	512GB		V	
	Sandisk	N/A	1TB			V
LCD Panel	AUO	B116XAN05.0	11.6"	V		
	New IPS KD	KD116N11-30NP-A9	11.6"		V	V
Barcode	ZEBRA	SE4710	N/A	V		
SD Card reader	N/A	N/A	N/A		V	
Smart Card	N/A	N/A	N/A		V	
USB 3.1 (Type C)	N/A	N/A	N/A			V
WLAN/ BT Module	Intel	Intel 9260NGW	--	V	V	V
WWAN Module	Sierra Wireless, Inc.	EM7511	--	V	V	V
GPS	GlobalSat	MC1010	--	V	V	
Battery	Getac Technology Corp.	BP3S1P2100-S	11.1Vdc, 2100mAh	V	V	V
Bottom Camera	Foxlink	FN80AF-443H	8M		V	
RFID	NXP	PN-7462	13.56MHz	V	V	

4. The above EUT information is declared by manufacturer and for more detailed features description please refers to the manufacturer's specifications or User's Manual.

### List of Accessory of End-product:

Battery	Brand Name	Getac Technology Corp.
	Model Name	BP3S1P2100-S
	Power Rating	11.1Vdc, 2100mAh
	Type	Li-ion

### **3. SAR Measurement System**

#### **3.1 Definition of Specific Absorption Rate (SAR)**

SAR is related to the rate at which energy is absorbed per unit mass in an object exposed to a radio field. The SAR distribution in a biological body is complicated and is usually carried out by experimental techniques or numerical modeling. The standard recommends limits for two tiers of groups, occupational/controlled and general population/uncontrolled, based on a person's awareness and ability to exercise control over his or her exposure. In general, occupational/controlled exposure limits are higher than the limits for general population/uncontrolled.

The SAR definition is the time derivative (rate) of the incremental energy (dW) absorbed by (dissipated in) an incremental mass (dm) contained in a volume element (dv) of a given density ( $\rho$ ). The equation description is as below:

$$\text{SAR} = \frac{d}{dt} \left( \frac{dW}{dm} \right) = \frac{d}{dt} \left( \frac{dW}{\rho dv} \right)$$

SAR is expressed in units of Watts per kilogram (W/kg)

SAR measurement can be related to the electrical field in the tissue by

$$\text{SAR} = \frac{\sigma |E|^2}{\rho}$$

Where:  $\sigma$  is the conductivity of the tissue,  $\rho$  is the mass density of the tissue and E is the RMS electrical field strength.

#### **3.2 SPEAG DASY52 System**

DASY52 system consists of high precision robot, probe alignment sensor, phantom, robot controller, controlled measurement server and near-field probe. The robot includes six axes that can move to the precision position of the DASY52 software defined. The DASY52 software can define the area that is detected by the probe. The robot is connected to controlled box. Controlled measurement server is connected to the controlled robot box. The DAE includes amplifier, signal multiplexing, AD converter, offset measurement and surface detection. It is connected to the Electro-optical coupler (ECO). The ECO performs the conversion from the optical into digital electric signal of the DAE and transfers data to the PC.

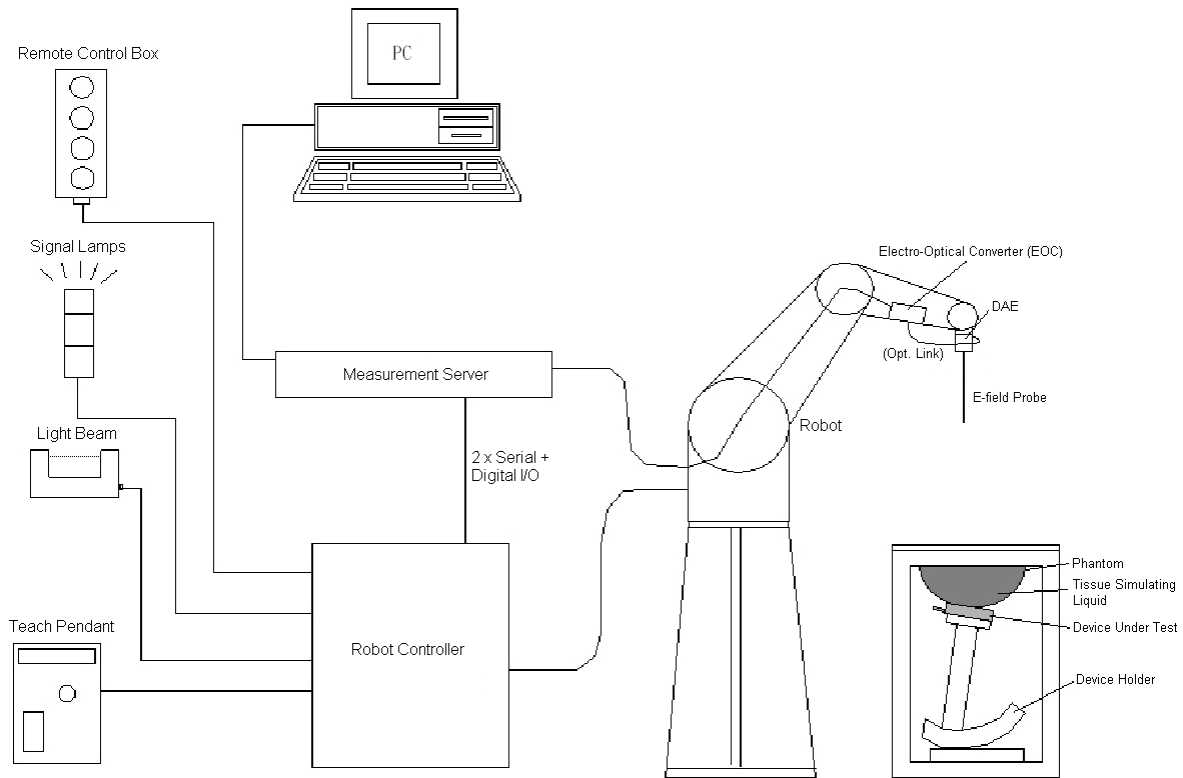

**Fig-3.1 SPEAG DASY52 System Setup**

### 3.2.1 Robot

The DASY52 systems use the high precision robots from Stäubli SA (France). For the 6-axis controller system, the robot controller version of CS8c from Stäubli is used. The Stäubli robot series have many features that are important for our application:

- High precision (repeatability  $\pm 0.035$  mm)
- High reliability (industrial design)
- Jerk-free straight movements
- Low ELF interference (the closed metallic construction shields against motor control fields)



**Fig-3.2 SPEAG DASY52 System**





# FCC SAR Test Report

## 3.2.2 Probes

The SAR measurement is conducted with the dosimetric probe. The probe is specially designed and calibrated for use in liquid with high permittivity. The dosimetric probe has special calibration in liquid at different frequency.

<b>Model</b>	EX3DV4	
<b>Construction</b>	Symmetrical design with triangular core. Built-in shielding against static charges. PEEK enclosure material (resistant to organic solvents, e.g., DGBE).	
<b>Frequency</b>	10 MHz to 6 GHz Linearity: $\pm 0.2$ dB	
<b>Directivity</b>	$\pm 0.3$ dB in HSL (rotation around probe axis) $\pm 0.5$ dB in tissue material (rotation normal to probe axis)	
<b>Dynamic Range</b>	10 $\mu$ W/g to 100 mW/g Linearity: $\pm 0.2$ dB (noise: typically $< 1 \mu$ W/g)	
<b>Dimensions</b>	Overall length: 337 mm (Tip: 20 mm) Tip diameter: 2.5 mm (Body: 12 mm) Typical distance from probe tip to dipole centers: 1 mm	

<b>Model</b>	ES3DV3	
<b>Construction</b>	Symmetrical design with triangular core. Interleaved sensors. Built-in shielding against static charges. PEEK enclosure material (resistant to organic solvents, e.g., DGBE).	
<b>Frequency</b>	10 MHz to 4 GHz Linearity: $\pm 0.2$ dB	
<b>Directivity</b>	$\pm 0.2$ dB in HSL (rotation around probe axis) $\pm 0.3$ dB in tissue material (rotation normal to probe axis)	
<b>Dynamic Range</b>	5 $\mu$ W/g to 100 mW/g Linearity: $\pm 0.2$ dB	
<b>Dimensions</b>	Overall length: 337 mm (Tip: 20 mm) Tip diameter: 3.9 mm (Body: 12 mm) Distance from probe tip to dipole centers: 2.0 mm	

<b>Model</b>	ET3DV6	
<b>Construction</b>	Symmetrical design with triangular core Built-in optical fiber for surface detection system. Built-in shielding against static charges. PEEK enclosure material (resistant to organic solvents, e.g., DGBE)	
<b>Frequency</b>	10 MHz to 2.3 GHz; Linearity: $\pm 0.2$ dB	
<b>Directivity</b>	$\pm 0.2$ dB in TSL (rotation around probe axis) $\pm 0.4$ dB in TSL (rotation normal to probe axis)	
<b>Dynamic Range</b>	5 $\mu$ W/g to 100 mW/g; Linearity: $\pm 0.2$ dB	
<b>Dimensions</b>	Overall length: 337 mm (Tip: 16 mm) Tip diameter: 6.8 mm (Body: 12 mm) Distance from probe tip to dipole centers: 2.7 mm	

## 3.2.3 Data Acquisition Electronics (DAE)

<b>Model</b>	DAE3, DAE4	
<b>Construction</b>	Signal amplifier, multiplexer, A/D converter and control logic. Serial optical link for communication with DASY embedded system (fully remote controlled). Two step probe touch detector for mechanical surface detection and emergency robot stop.	
<b>Measurement Range</b>	-100 to +300 mV (16 bit resolution and two range settings: 4mV, 400mV)	
<b>Input Offset Voltage</b>	$< 5\mu$ V (with auto zero)	
<b>Input Bias Current</b>	$< 50$ fA	
<b>Dimensions</b>	60 x 60 x 68 mm	

# FCC SAR Test Report

## 3.2.4 Phantoms

<b>Model</b>	Twin SAM	
<b>Construction</b>	The shell corresponds to the specifications of the Specific Anthropomorphic Mannequin (SAM) phantom defined in IEEE 1528 and IEC 62209-1. It enables the dosimetric evaluation of left and right hand phone usage as well as body mounted usage at the flat phantom region. A cover prevents evaporation of the liquid. Reference markings on the phantom allow the complete setup of all predefined phantom positions and measurement grids by teaching three points with the robot.	
<b>Material</b>	Vinylester, glass fiber reinforced (VE-GF)	
<b>Shell Thickness</b>	2 ± 0.2 mm (6 ± 0.2 mm at ear point)	
<b>Dimensions</b>	Length: 1000 mm Width: 500 mm Height: adjustable feet	
<b>Filling Volume</b>	approx. 25 liters	

<b>Model</b>	ELI	
<b>Construction</b>	Phantom for compliance testing of handheld and body-mounted wireless devices in the frequency range of 30 MHz to 6 GHz. ELI is fully compatible with the IEC 62209-2 standard and all known tissue simulating liquids. ELI has been optimized regarding its performance and can be integrated into our standard phantom tables. A cover prevents evaporation of the liquid. Reference markings on the phantom allow installation of the complete setup, including all predefined phantom positions and measurement grids, by teaching three points. The phantom is compatible with all SPEAG dosimetric probes and dipoles.	
<b>Material</b>	Vinylester, glass fiber reinforced (VE-GF)	
<b>Shell Thickness</b>	2.0 ± 0.2 mm (bottom plate)	
<b>Dimensions</b>	Major axis: 600 mm Minor axis: 400 mm	
<b>Filling Volume</b>	approx. 30 liters	

# FCC SAR Test Report

## 3.2.5 Device Holder

<b>Model</b>	Mounting Device	
<b>Construction</b>	In combination with the Twin SAM Phantom or ELI4, the Mounting Device enables the rotation of the mounted transmitter device in spherical coordinates. Rotation point is the ear opening point. Transmitter devices can be easily and accurately positioned according to IEC, IEEE, FCC or other specifications. The device holder can be locked for positioning at different phantom sections (left head, right head, flat).	
<b>Material</b>	POM	

<b>Model</b>	Laptop Extensions Kit	
<b>Construction</b>	Simple but effective and easy-to-use extension for Mounting Device that facilitates the testing of larger devices according to IEC 62209-2 (e.g., laptops, cameras, etc.). It is lightweight and fits easily on the upper part of the Mounting Device in place of the phone positioner.	
<b>Material</b>	POM, Acrylic glass, Foam	

## 3.2.6 System Validation Dipoles

<b>Model</b>	D-Serial	
<b>Construction</b>	Symmetrical dipole with 1/4 balun. Enables measurement of feed point impedance with NWA. Matched for use near flat phantoms filled with tissue simulating solutions.	
<b>Frequency</b>	750 MHz to 5800 MHz	
<b>Return Loss</b>	> 20 dB	
<b>Power Capability</b>	> 100 W (f < 1GHz), > 40 W (f > 1GHz)	

**3.2.7 Tissue Simulating Liquids**

For SAR measurement of the field distribution inside the phantom, the phantom must be filled with homogeneous tissue simulating liquid to a depth of at least 15 cm. For head SAR testing, the liquid height from the ear reference point (ERP) of the phantom to the liquid top surface is larger than 15 cm. For body SAR testing, the liquid height from the center of the flat phantom to the liquid top surface is larger than 15 cm. The nominal dielectric values of the tissue simulating liquids in the phantom and the tolerance of 5% are listed in Table-3.1.

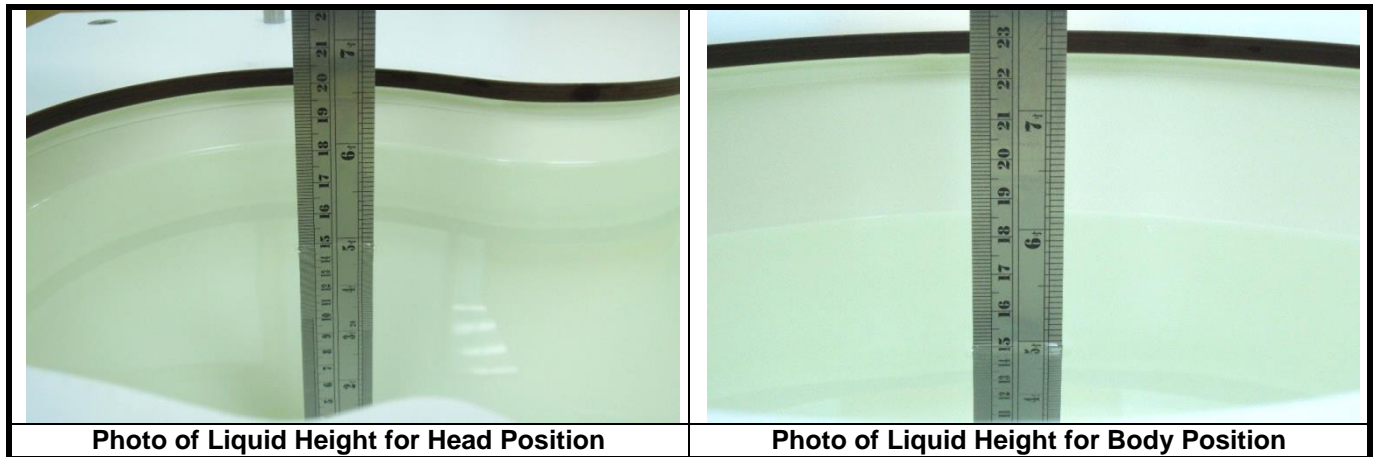

The dielectric properties of the head tissue simulating liquids are defined in IEEE 1528, and KDB 865664 D01 Appendix A. For the body tissue simulating liquids, the dielectric properties are defined in KDB 865664 D01 Appendix A. The dielectric properties of the tissue simulating liquids were verified prior to the SAR evaluation using a dielectric assessment kit and a network analyzer.

**Table-3.1 Targets of Tissue Simulating Liquid**

Frequency (MHz)	Target Permittivity	Range of $\pm 5\%$	Target Conductivity	Range of $\pm 5\%$
750	41.9	39.8 ~ 44.0	0.89	0.85 ~ 0.93
835	41.5	39.4 ~ 43.6	0.90	0.86 ~ 0.95
900	41.5	39.4 ~ 43.6	0.97	0.92 ~ 1.02
1450	40.5	38.5 ~ 42.5	1.20	1.14 ~ 1.26
1640	40.3	38.3 ~ 42.3	1.29	1.23 ~ 1.35
1750	40.1	38.1 ~ 42.1	1.37	1.30 ~ 1.44
1800	40.0	38.0 ~ 42.0	1.40	1.33 ~ 1.47
1900	40.0	38.0 ~ 42.0	1.40	1.33 ~ 1.47
2000	40.0	38.0 ~ 42.0	1.40	1.33 ~ 1.47
2300	39.5	37.5 ~ 41.5	1.67	1.59 ~ 1.75
2450	39.2	37.2 ~ 41.2	1.80	1.71 ~ 1.89
2600	39.0	37.1 ~ 41.0	1.96	1.86 ~ 2.06
3500	37.9	36.0 ~ 39.8	2.91	2.76 ~ 3.06
5200	36.0	34.2 ~ 37.8	4.66	4.43 ~ 4.89
5300	35.9	34.1 ~ 37.7	4.76	4.52 ~ 5.00
5500	35.6	33.8 ~ 37.4	4.96	4.71 ~ 5.21
5600	35.5	33.7 ~ 37.3	5.07	4.82 ~ 5.32
5800	35.3	33.5 ~ 37.1	5.27	5.01 ~ 5.53

The following table gives the recipes for tissue simulating liquids.

**Table-3.2 Recipes of Tissue Simulating Liquid**

Tissue Type	Bactericide	DGBE	HEC	NaCl	Sucrose	Triton X-100	Water	Diethylene Glycol Mono-hexylether
H750	0.2	-	0.2	1.5	56.0	-	42.1	-
H835	0.2	-	0.2	1.5	57.0	-	41.1	-
H900	0.2	-	0.2	1.4	58.0	-	40.2	-
H1450	-	43.3	-	0.6	-	-	56.1	-
H1640	-	45.8	-	0.5	-	-	53.7	-
H1750	-	47.0	-	0.4	-	-	52.6	-
H1800	-	44.5	-	0.3	-	-	55.2	-
H1900	-	44.5	-	0.2	-	-	55.3	-
H2000	-	44.5	-	0.1	-	-	55.4	-
H2300	-	44.9	-	0.1	-	-	55.0	-
H2450	-	45.0	-	0.1	-	-	54.9	-
H2600	-	45.1	-	0.1	-	-	54.8	-
H3500	-	8.0	-	0.2	-	20.0	71.8	-
H5G	-	-	-	-	-	17.2	65.5	17.3

### 3.3 SAR System Verification

The system check verifies that the system operates within its specifications. It is performed daily or before every SAR measurement. The system check uses normal SAR measurements in the flat section of the phantom with a matched dipole at a specified distance. The system verification setup is shown as below.

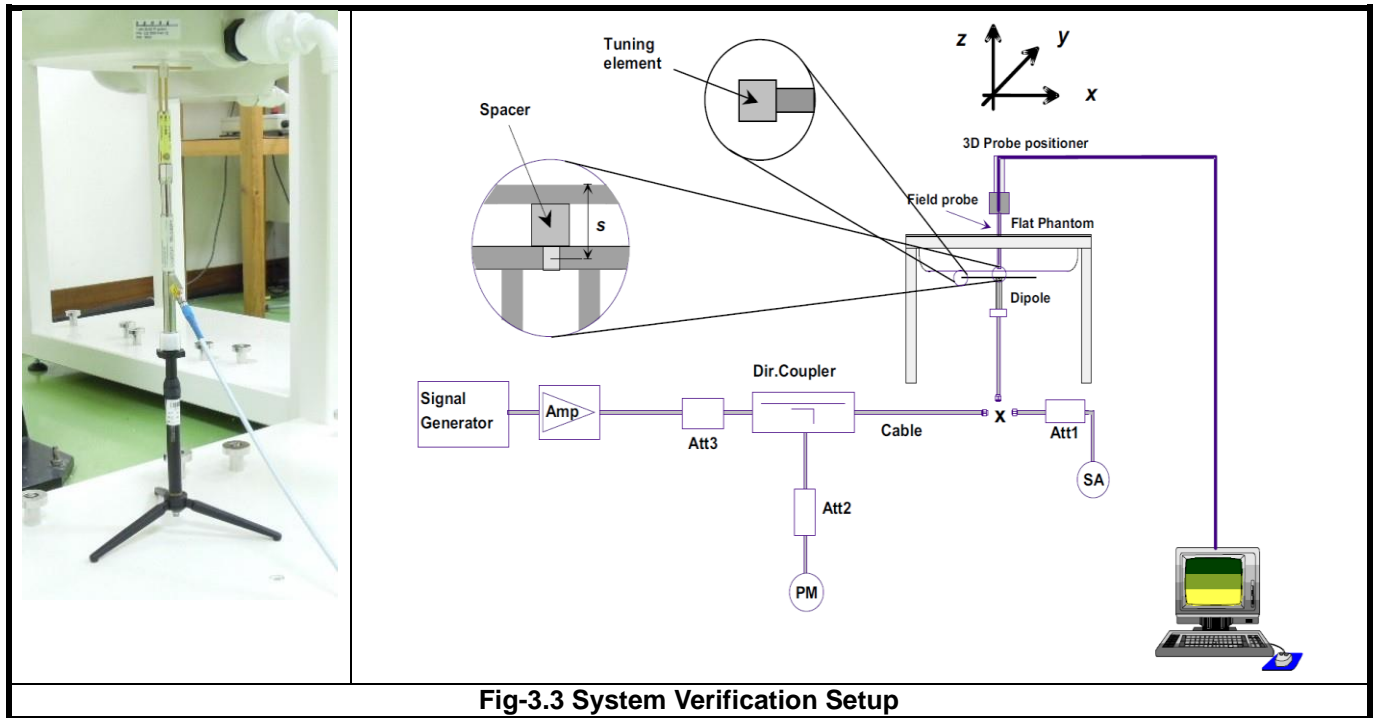

**Fig-3.3 System Verification Setup**

The validation dipole is placed beneath the flat phantom with the specific spacer in place. The distance spacer is touch the phantom surface with a light pressure at the reference marking and be oriented parallel to the long side of the phantom. The spectrum analyzer measures the forward power at the location of the system check dipole connector. The signal generator is adjusted for the desired forward power (250 mW is used for 700 MHz to 3 GHz, 100 mW is used for 3.5 GHz to 6 GHz) at the dipole connector and the power meter is read at that level. After connecting the cable to the dipole, the signal generator is readjusted for the same reading at power meter.

After system check testing, the SAR result will be normalized to 1W forward input power and compared with the reference SAR value derived from validation dipole certificate report. The deviation of system check should be within 10 %.

**3.4 SAR Measurement Procedure**

According to the SAR test standard, the recommended procedure for assessing the peak spatial-average SAR value consists of the following steps:

- (a) Power reference measurement
- (b) Area scan
- (c) Zoom scan
- (d) Power drift measurement

The SAR measurement procedures for each of test conditions are as follows:

- (a) Make EUT to transmit maximum output power
- (b) Measure conducted output power through RF cable
- (c) Place the EUT in the specific position of phantom
- (d) Perform SAR testing steps on the DASY system
- (e) Record the SAR value

**3.4.1 Area & Zoom Scan Procedure**

First Area Scan is used to locate the approximate location(s) of the local peak SAR value(s). The measurement grid within an Area Scan is defined by the grid extent, grid step size and grid offset. Next, in order to determine the EM field distribution in a three-dimensional spatial extension, Zoom Scan is required. The Zoom Scan is performed around the highest E-field value to determine the averaged SAR-distribution over 10 g. According to KDB 865664 D01, the resolution for Area and Zoom scan is specified in the table below.

Items	<= 2 GHz	2-3 GHz	3-4 GHz	4-5 GHz	5-6 GHz
Area Scan ( $\Delta x, \Delta y$ )	<= 15 mm	<= 12 mm	<= 12 mm	<= 10 mm	<= 10 mm
Zoom Scan ( $\Delta x, \Delta y$ )	<= 8 mm	<= 5 mm	<= 5 mm	<= 4 mm	<= 4 mm
Zoom Scan ( $\Delta z$ )	<= 5 mm	<= 5 mm	<= 4 mm	<= 3 mm	<= 2 mm
Zoom Scan Volume	>= 30 mm	>= 30 mm	>= 28 mm	>= 25 mm	>= 22 mm

**Note:**

When zoom scan is required and report SAR is <= 1.4 W/kg, the zoom scan resolution of  $\Delta x / \Delta y$  (2-3GHz: <= 8 mm, 3-4GHz: <= 7 mm, 4-6GHz: <= 5 mm) may be applied.

**3.4.2 Volume Scan Procedure**

The volume scan is used for assess overlapping SAR distributions for antennas transmitting in different frequency bands. It is equivalent to an oversized zoom scan used in standalone measurements. The measurement volume will be used to enclose all the simultaneous transmitting antennas. For antennas transmitting simultaneously in different frequency bands, the volume scan is measured separately in each frequency band. In order to sum correctly to compute the 1g aggregate SAR, the EUT remain in the same test position for all measurements and all volume scan use the same spatial resolution and grid spacing. When all volume scan were completed, the software, SEMCAD postprocessor can combine and subsequently superpose these measurement data to calculating the multiband SAR.



### 3.4.3 Power Drift Monitoring

All SAR testing is under the EUT install full charged battery and transmit maximum output power. In DASY measurement software, the power reference measurement and power drift measurement procedures are used for monitoring the power drift of EUT during SAR test. Both these procedures measure the field at a specified reference position before and after the SAR testing. The software will calculate the field difference in dB. If the power drift more than 5%, the SAR will be retested.

### 3.4.4 Spatial Peak SAR Evaluation

The procedure for spatial peak SAR evaluation has been implemented according to the test standard. It can be conducted for 1g and 10g, as well as for user-specific masses. The DASY software includes all numerical procedures necessary to evaluate the spatial peak SAR value.

The base for the evaluation is a "cube" measurement. The measured volume must include the 1g and 10g cubes with the highest averaged SAR values. For that purpose, the center of the measured volume is aligned to the interpolated peak SAR value of a previously performed area scan.

The entire evaluation of the spatial peak values is performed within the post-processing engine (SEMCAD). The system always gives the maximum values for the 1g and 10g cubes. The algorithm to find the cube with highest averaged SAR is divided into the following stages:

- (a) Extraction of the measured data (grid and values) from the Zoom Scan
- (b) Calculation of the SAR value at every measurement point based on all stored data (A/D values and measurement parameters)
- (c) Generation of a high-resolution mesh within the measured volume
- (d) Interpolation of all measured values from the measurement grid to the high-resolution grid
- (e) Extrapolation of the entire 3-D field distribution to the phantom surface over the distance from sensor to surface
- (f) Calculation of the averaged SAR within masses of 1g and 10g

### 3.4.5 SAR Averaged Methods

In DASY, the interpolation and extrapolation are both based on the modified Quadratic Shepard's method. The interpolation scheme combines a least-square fitted function method and a weighted average method which are the two basic types of computational interpolation and approximation.

Extrapolation routines are used to obtain SAR values between the lowest measurement points and the inner phantom surface. The extrapolation distance is determined by the surface detection distance and the probe sensor offset. The uncertainty increases with the extrapolation distance. To keep the uncertainty within 1% for the 1 g and 10 g cubes, the extrapolation distance should not be larger than 5 mm.



## 4. SAR Measurement Evaluation

### 4.1 EUT Configuration and Setting

#### <Connections between EUT and System Simulator>

For WWAN SAR testing, the EUT was linked and controlled by base station emulator. Communication between the EUT and the emulator was established by air link. The distance between the EUT and the communicating antenna of the emulator is larger than 50 cm and the output power radiated from the emulator antenna is at least 30 dB smaller than the output power of EUT. The EUT was set from the emulator to radiate maximum output power during SAR testing.

#### <Considerations Related to WCDMA for Setup and Testing>

##### Release 5 HSDPA Data Devices

The 3G SAR test reduction procedure is applied to body SAR with 12.2 kbps RMC as the primary mode. Otherwise, body SAR for HSDPA is measured using an FRC with H-Set 1 in Sub-test 1 and a 12.2 kbps RMC configured in Test Loop Mode 1, for the highest reported SAR configuration in 12.2 kbps RMC without HSDPA. HSDPA is configured according to the applicable UE category of a test device. The number of HS-DSCH / HS-PDSCHs, HARQ processes, minimum inter-TTI interval, transport block sizes and RV coding sequence are defined by the H-set. To maintain a consistent test configuration and stable transmission conditions, QPSK is used in the H-set for SAR testing. HS-DPCCH should be configured with a CQI feedback cycle of 4 ms and a CQI repetition factor of 2 to maintain a constant rate of active CQI slots. DPCCH and DPDCH gain factors ( $\beta_c$ ,  $\beta_d$ ), and HS-DPCCH power offset parameters ( $\Delta_{ACK}$ ,  $\Delta_{NACK}$ ,  $\Delta_{CQI}$ ) are set according to values indicated in below. The CQI value is determined by the UE category, transport block size, number of HS-PDSCHs and modulation used in the H-set.

Sub-test	$\beta_c$	$\beta_d$	$\beta_d$ (SF)	$\beta_d/\beta_c$	$\beta_{HS}^{(1)(2)}$	CM <sup>(3)</sup> (dB)	MPR <sup>(3)</sup> (dB)
1	2/15	15/15	64	2/15	4/15	0.0	0.0
2	12/15 <sup>(4)</sup>	15/15 <sup>(4)</sup>	64	12/15 <sup>(4)</sup>	24/15	1.0	0.0
3	15/15	8/15	64	15/8	30/15	1.5	0.5
4	15/15	4/15	64	15/4	30/15	1.5	0.5

Note 1:  $\Delta_{ACK}$ ,  $\Delta_{NACK}$  and  $\Delta_{CQI}$  = 30/15 with  $\beta_{HS}$  = 30/15 \*  $\beta_c$ .  
 Note 2: For the HS-DPCCH power mask requirement test in clause 5.2C, 5.7A, and the Error Vector Magnitude (EVM) with HS-DPCCH test in clause 5.13.1A, and HSDPA EVM with phase discontinuity in clause 5.13.1AA,  $\Delta_{ACK}$  and  $\Delta_{NACK}$  = 30/15 with  $\beta_{HS}$  = 30/15 \*  $\beta_c$ , and  $\Delta_{CQI}$  = 24/15 with  $\beta_{HS}$  = 24/15 \*  $\beta_c$ .  
 Note 3: CM = 1 for  $\beta_d/\beta_c$  = 12/15,  $\beta_{HS}/\beta_c$  = 24/15. For all other combinations of DPDCH, DPCCH and HS-DPCCH the MPR is based on the relative CM difference. This is applicable for only UEs that support HSDPA in release 6 and later releases.  
 Note 4: For subtest 2 the  $\beta_d/\beta_c$  ratio of 12/15 for the TFC during the measurement period (TF1, TF0) is achieved by setting the signalled gain factors for the reference TFC (TF1, TF1) to  $\beta_c$  = 11/15 and  $\beta_d$  = 15/15.

# FCC SAR Test Report

## Release 6 HSUPA Data Devices

The 3G SAR test reduction procedure is applied to body SAR with 12.2 kbps RMC as the primary mode. Otherwise, body SAR for HSPA is measured with E-DCH Sub-test 5, using H-Set 1 and QPSK for FRC and a 12.2 kbps RMC configured in Test Loop Mode 1 and power control algorithm 2, according to the highest reported body SAR configuration in 12.2 kbps RMC without HSPA. When VOIP applies to head exposure, the 3G SAR test reduction procedure is applied with 12.2 kbps RMC as the primary mode. Otherwise, the same HSPA configuration used for body SAR measurements are applied to head exposure testing. Due to inner loop power control requirements in HSPA, a communication test set is required for output power and SAR tests. The 12.2 kbps RMC, FRC H-set 1 and E-DCH configurations for HSPA are configured according to the  $\beta$  values indicated in below.

Sub-test	$\beta_c$	$\beta_d$	$\beta_d$ (SF)	$\beta_c / \beta_d$	$\beta_{HS}^{(1)}$	$\beta_{ec}$	$\beta_{ed}^{(4)(5)}$	$\beta_{ed}$ (SF)	$\beta_{ed}$ (Codes)	CM <sup>(2)</sup> (dB)	MPR <sup>(2)(6)</sup> (dB)	AG <sup>(5)</sup> Index	E-TFCI
1	11/15 <sup>(3)</sup>	15/15 <sup>(3)</sup>	64	11/15 <sup>(3)</sup>	22/15	209/225	1309/225	4	1	1.0	0.0	20	75
2	6/15	15/15	64	6/15	12/15	12/15	94/75	4	1	3.0	2.0	12	67
3	15/15	9/15	64	15/9	30/15	30/15	$\beta_{ed1}$ : 47/15 $\beta_{ed2}$ : 47/15	4 4	2	2.0	1.0	15	92
4	2/15	15/15	64	2/15	4/15	2/15	56/75	4	1	3.0	2.0	17	71
5	15/15	0	-	-	5/15	5/15	47/15	4	1	1.0	0.0	12	67

Note 1: For sub-test 1 to 4,  $\Delta_{ACK}$ ,  $\Delta_{NACK}$  and  $\Delta_{CQI} = 30/15$  with  $\beta_{HS} = 30/15 * \beta_c$ . For sub-test 5,  $\Delta_{ACK}$ ,  $\Delta_{NACK}$  and  $\Delta_{CQI} = 5/15$  with  $\beta_{HS} = 5/15 * \beta_c$ .  
 Note 2: CM = 1 for  $\beta_c/\beta_d = 12/15$ ,  $\beta_{HS}/\beta_c = 24/15$ . For all other combinations of DPDCH, DPCCCH, HS-DPCCH, E-DPDCH and E-DPCCH the MPR is based on the relative CM difference.  
 Note 3: For subtest 1 the  $\beta_c/\beta_d$  ratio of 11/15 for the TFC during the measurement period (TF1, TF0) is achieved by setting the signalled gain factors for the reference TFC (TF1, TF1) to  $\beta_c = 10/15$  and  $\beta_d = 15/15$ .  
 Note 4: In case of testing by UE using E-DPDCH Physical Layer category 1, Sub-test 3 is omitted according to TS25.306 Table 5.1g.  
 Note 5:  $\beta_{ed}$  can not be set directly; it is set by Absolute Grant Value.  
 Note 6: For subtests 2, 3 and 4, UE may perform E-DPDCH power scaling at max power which could results in slightly smaller MPR values.

## HSPA+ SAR Guidance

The 3G SAR test reduction procedure is applied to HSPA+ (uplink) with 12.2 kbps RMC as the primary mode. Otherwise, when SAR is required for Rel. 6 HSPA, SAR is required for Rel. 7 HSPA+. Power is measured for HSPA+ that supports uplink 16QAM according to configurations in Table C.11.1.4 of 3GPP TS 34.121-1 to determine SAR test reduction.

Sub-test	$\beta_c^{(3)}$	$\beta_d$	$\beta_{HS}^{(1)}$	$\beta_{ec}$	$\beta_{ed}^{(4)}$ (2xSF2)	$\beta_{ed}^{(4)}$ (2xSF4)	CM <sup>(2)</sup> (dB)	MPR <sup>(2)</sup> (dB)	AG <sup>(4)</sup> Index	E-TFCI <sup>(5)</sup>	E-TFCI (boost)
1	1	0	30/15	30/15	$\beta_{ed1}$ : 30/15 $\beta_{ed2}$ : 30/15	$\beta_{ed3}$ : 24/15 $\beta_{ed4}$ : 24/15	3.5	2.5	14	105	105

Note 1:  $\Delta_{ACK}$ ,  $\Delta_{NACK}$  and  $\Delta_{CQI} = 30/15$  with  $\beta_{HS} = 30/15 * \beta_c$ .  
 Note 2: CM = 3.5 and the MPR is based on the relative CM difference, MPR = MAX(CM-1,0).  
 Note 3: DPDCH is not configured, therefore the  $\beta_c$  is set to 1 and  $\beta_d = 0$  by default.  
 Note 4:  $\beta_{ed}$  can not be set directly; it is set by Absolute Grant Value.  
 Note 5: All the sub-tests require the UE to transmit 2SF2+2SF4 16QAM EDCH and they apply for UE using E-DPDCH category 7. E-DCH TTI is set to 2ms TTI and E-DCH table index = 2. To support these E-DCH configurations DPDCH is not allocated. The UE is signalled to use the extrapolation algorithm.

## DC-HSDPA SAR Guidance

The 3G SAR test reduction procedure is applied to DC-HSDPA with 12.2 kbps RMC as the primary mode. Otherwise, when SAR is required for Rel. 5 HSDPA, SAR is required for Rel. 8 DC-HSDPA. Power is measured for DC-HSDPA according to the H-Set 12, FRC configuration in Table C.8.1.12 of 3GPP TS 34.121-1 to determine SAR test reduction. A primary and a secondary serving HS-DSCH Cell are required to perform the power measurement and for the results to be acceptable.

## FCC SAR Test Report

### <Considerations Related to LTE for Setup and Testing>

This device contains LTE transmitter which follows 3GPP standards, is category 3, supports both QPSK and QAM modulations, and supported LTE band and channel bandwidth is listed in below. The output power was tested per 3GPP TS 36.521-1 maximum transmit procedures for both QPSK and QAM modulation. The results please refer to section 4.6 of this report.

EUT Supported LTE Band and Channel Bandwidth						
LTE Band	BW 1.4 MHz	BW 3 MHz	BW 5 MHz	BW 10 MHz	BW 15 MHz	BW 20 MHz
2	V	V	V	V	V	V
4	V	V	V	V	V	V
5	V	V	V	V		
7			V	V	V	V
12	V	V	V	V		
13			V	V		
14			V	V		
26	V	V	V	V	V	
41			V	V	V	V
66	V	V	V	V	V	V

The LTE maximum power reduction (MPR) in accordance with 3GPP TS 36.101 is active all times during LTE operation. The allowed MPR for the maximum output power is specified in below.

LTE Band	Modulation	Channel Bandwidth / RB Configurations						LTE MPR Setting (dB)
		BW 1.4 MHz	BW 3 MHz	BW 5 MHz	BW 10 MHz	BW 15 MHz	BW 20 MHz	
12	QPSK	> 5	> 4	> 8	> 12	> 16	> 18	1
	16QAM	<= 5	<= 4	<= 8	<= 12	<= 16	<= 18	1
	16QAM	> 5	> 4	> 8	> 12	> 16	> 18	2
	64QAM	<= 5	<= 4	<= 8	<= 12	<= 16	<= 18	2
	64QAM	> 5	> 4	> 8	> 12	> 16	> 18	3

LTE Band	Modulation	Channel Bandwidth / RB Configurations						LTE MPR Setting (dB)
		BW 1.4 MHz	BW 3 MHz	BW 5 MHz	BW 10 MHz	BW 15 MHz	BW 20 MHz	
2, 4, 5, 7, 13, 14, 26, 41, 66	QPSK	> 5	> 4	> 8	> 12	> 16	> 18	0
	16QAM	<= 5	<= 4	<= 8	<= 12	<= 16	<= 18	0
	16QAM	> 5	> 4	> 8	> 12	> 16	> 18	0
	64QAM	<= 5	<= 4	<= 8	<= 12	<= 16	<= 18	0
	64QAM	> 5	> 4	> 8	> 12	> 16	> 18	0

**Note:** MPR is according to the standard and implemented in the circuit (mandatory).

In addition, the device is compliant with additional maximum power reduction (A-MPR) requirements defined in 3GPP TS 36.101 section 6.2.4 that was disabled for all FCC compliance testing.

During LTE SAR testing, the related parameters of operating band, channel bandwidth, uplink channel number, modulation type, and RB was set in base station simulator. When the EUT has registered and communicated to base station simulator, the simulator set to make EUT transmitting the maximum radiated power.

# FCC SAR Test Report

## TDD-LTE Setup Configurations

According to KDB 941225 D05, SAR testing for TDD-LTE device must be tested using a fixed periodic duty factor according to the highest transmission duty factor implemented for the device and supported by the defined 3GPP TDD-LTE configurations. The TDD-LTE of this device supports frame structure type 2 defined in 3GPP TS 36.211 section 4.2, and the frame structure configuration can be referred to below.

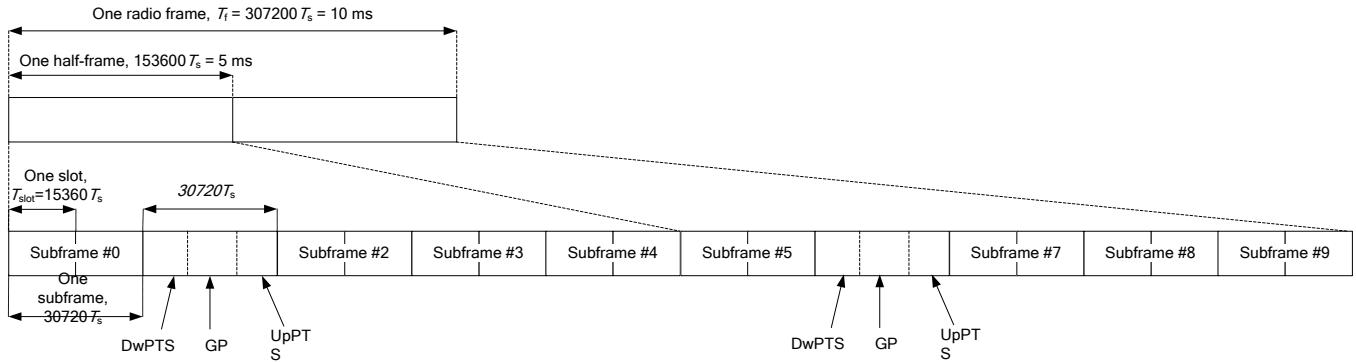

3GPP TS 36.211 Figure 4.2-1: Frame Structure Type 2

Special Subframe Configuration	Normal Cyclic Prefix in Downlink			Extended Cyclic Prefix in Downlink		
	DwPTS	UpPTS		DwPTS	UpPTS	
		Normal Cyclic Prefix in Uplink	Extended Cyclic Prefix in Uplink		Normal Cyclic Prefix in Uplink	Extended Cyclic Prefix in Uplink
0	6592 · Ts	2192 · Ts	2560 · Ts	7680 · Ts	2192 · Ts	2560 · Ts
1	19760 · Ts			20480 · Ts		
2	21952 · Ts			23040 · Ts		
3	24144 · Ts			25600 · Ts		
4	26336 · Ts			7680 · Ts		
5	6592 · Ts	4384 · Ts	5120 · Ts	20480 · Ts	4384 · Ts	5120 · Ts
6	19760 · Ts			23040 · Ts		
7	21952 · Ts			12800 · Ts		
8	24144 · Ts	-	-	-	-	-
9	13168 · Ts	-	-	-	-	-

3GPP TS 36.211 Table 4.2-1: Configuration of Special Subframe

Uplink-Downlink Configuration	Downlink-to-Uplink Switch-Point Periodicity	Subframe Number										
		0	1	2	3	4	5	6	7	8	9	
0	5 ms	D	S	U	U	U	D	S	U	U	U	
1	5 ms	D	S	U	U	D	D	S	U	U	D	
2	5 ms	D	S	U	D	D	D	S	U	D	D	
3	10 ms	D	S	U	U	U	D	D	D	D	D	
4	10 ms	D	S	U	U	D	D	D	D	D	D	
5	10 ms	D	S	U	D	D	D	D	D	D	D	
6	5 ms	D	S	U	U	U	D	S	U	U	D	

3GPP TS 36.211 Table 4.2-2: Uplink-Downlink Configurations

## FCC SAR Test Report

The variety of different TD-LTE uplink-downlink configurations allows a network operator to allocate the network's capacity between uplink and downlink traffic to meet the needs of the network. The uplink duty cycle of these seven configurations can readily be computed and shown in below.

UL-DL Configuration	0	1	2	3	4	5	6
Highest Duty-Cycle	63.33%	43.33%	23.33%	31.67%	21.67%	11.67%	53.33%

Considering the highest transmission duty cycle, TDD-LTE was tested using Uplink-Downlink Configuration 0 with 6 uplink subframe and 2 special subframe. The special subframe was set to special subframe configuration 7 using extended cyclic prefix uplink. Therefore, SAR testing for TDD-LTE was performed at the maximum output power with highest transmission duty cycle of 63.33%.

### LTE Downlink Carrier Aggregation (CA) Setup Configurations

LTE Carrier Aggregation (CA) was defined in 3GPP release 10 and higher. The LTE device in CA mode has one Primary Component Carrier (PCC) and one or more Secondary Component Carriers (SCC). PCC acts as the anchor carrier and can optionally cross-schedule data transmission on SCC. The RRC connection is only handled by one cell, the PCC for downlink and uplink communications. After making a data connection to the PCC, the LTE device adds the SCC on the downlink only. All uplink communications and acknowledgements remain identical to release 8 specifications on the PCC. The combinations of downlink carrier aggregation supported by this device are listed in below.

### LTE CA Configurations and Bandwidth Combination Sets defined for Intra-Band Contiguous CA

Downlink CA Configuration	Component carriers in order of increasing carrier frequency			Maximum Aggregated Bandwidth (MHz)	Bandwidth Combination Set
	Channel bandwidths for carrier-1 (MHz)	Channel bandwidths for carrier-2 (MHz)	Channel bandwidths for carrier-3 (MHz)		
CA_2C	5	20		40	0
	10	15, 20			
	15	10, 15, 20			
	20	5, 10, 15, 20			
CA_7B	15	5		20	0
CA_7C	15	15		40	0
	20	20			
	10	20		40	1
	15	15, 20			
	20	10, 15, 20			
	15	10, 15			
CA_41D	20	15, 20		60	0
	10	20	15		
	15	20	10, 15		
	15	10, 15, 20	20		
	20	15, 20	10		
	20	10, 15, 20	15, 20		
CA_66B	5	5, 10, 15		20	0
	10	5, 10			
	15	5			
CA_66C	5	20		40	0
	10	15, 20			
	15	10, 15, 20			
	20	5, 10, 15, 20			

# FCC SAR Test Report

## LTE CA Configurations and Bandwidth Combination Sets defined for Intra-Band Non-Contiguous CA

Downlink CA Configuration	Component Carriers in order of Increasing Carrier Frequency			Maximum Aggregated Bandwidth (MHz)	Bandwidth Combination Set
	Channel Bandwidths for Carrier-1 (MHz)	Channel Bandwidths for Carrier-2 (MHz)	Channel Bandwidths for Carrier-3 (MHz)		
CA_2A-2A	5, 10, 15, 20	5, 10, 15, 20		40	0
CA_4A-4A	5, 10, 15, 20	5, 10, 15, 20		40	0
	5, 10	5, 10		20	1
CA_66A-66B	5, 10, 15, 20	Refer to CA_66B (BCS0)		40	0
	Refer to CA_66B (BCS0)		5, 10, 15, 20		
CA_66A-66C	5, 10, 15, 20	Refer to CA_66C (BCS0)		60	0
	Refer to CA_66C (BCS0)		5, 10, 15, 20		

## LTE CA Configurations and Bandwidth Combination Sets defined for Inter-Band CA (Two Bands)

Downlink CA Configuration	LTE Bands	Channel Bandwidths for Carrier (MHz)	Maximum Aggregated Bandwidth (MHz)	Bandwidth Combination Set
CA_2A-4A	2	1.4, 3, 5, 10, 15, 20	40	0
	4	5, 10, 15, 20		
	2	5, 10	20	1
	4	5, 10		
CA_2A-2A-5A	2	5, 10, 15, 20	40	2
	4	5, 10, 15, 20		
CA_2A-7A	2	Refer to CA_2A-2A (BCS0)	50	0
	5	5, 10		
CA_2A-7A-7A	2	5, 10, 15, 20	40	0
	7	5, 10, 15, 20		
CA_2A-12A	2	5, 10, 15, 20	60	0
	7	Refer to CA_7A-7A (BCS1)		
	2	5, 10, 15, 20	30	0
	12	5, 10		
	2	5, 10, 15, 20		
CA_2A-12A-12A	12	3, 5, 10	30	1
	2	5, 10		
CA_2A-13A	2	5, 10	20	2
	12	5, 10		
	2	Refer to CA_2A-2A (BCS0)	50	0
	12	5, 10		
CA_2A-2A-13A	2	5, 10, 15, 20	30	0
	13	10		
	2	5, 10	20	1
13	10			
CA_2A-29A	2	Refer to CA_2A-2A (BCS0)	50	0
	13	10		
	2	5, 10	20	0
	29	3, 5, 10		
	2	5, 10	20	1
	29	5, 10		
CA_2A-46A	2	5, 10, 15, 20	30	2
	29	5, 10		
	2	5, 10, 15, 20	40	0
46	20			

# FCC SAR Test Report

CA_2A-66A	2	1.4, 3, 5, 10, 15, 20	40	0
	66	5, 10, 15, 20		
	2	5, 10	20	1
	66	5, 10		
	2	5, 10, 15, 20	40	2
66	5, 10, 15, 20			
CA_2A-66B	2	5, 10, 15, 20	40	0
	66	Refer to CA_66B (BCS0)		
CA_2A-66C	2	5, 10, 15, 20	60	0
	66	Refer to CA_66C (BCS0)		
CA_2A-66A-66A	2	5, 10, 15, 20	60	0
	66	Refer to CA_66A-66A (BCS0)		
CA_4A-5A	4	5, 10	20	0
	5	5, 10		
	4	5, 10, 15, 20	30	1
	5	5, 10		
CA_4A-4A-5A	4	Refer to CA_4A-4A (BCS0)	50	0
	5	5, 10		
CA_4A-7A	4	5, 10	30	0
	7	5, 10, 15, 20		
	4	5, 10, 15, 20	40	1
	7	5, 10, 15, 20		
CA_4A-7A-7A	4	5, 10, 15, 20	60	0
	7	Refer to the CA_7A-7A (BCS1)		
CA_4A-12A	4	1.4, 3, 5, 10	20	0
	12	5, 10		
	4	1.4, 3, 5, 10, 15, 20	30	1
	12	5, 10		
	4	5, 10, 15, 20	30	2
	12	3, 5, 10		
	4	5, 10	20	3
	12	5, 10		
	4	5, 10, 15, 20	30	4
	12	5, 10		
4	5, 10, 15	20	5	
12	5			
CA_4A-4A-12A	4	Refer to CA_4A-4A (BCS0)	50	0
	12	5, 10		
CA_4A-13A	4	5, 10, 15, 20	30	0
	13	10		
	4	5, 10	20	1
	13	10		
CA_4A-4A-13A	4	Refer to CA_4A-4A (BCS0)	50	0
	13	10		
CA_4A-29A	4	5, 10	20	0
	29	3, 5, 10		
	4	5, 10	20	1
	29	5, 10		
	4	5, 10, 15, 20	30	2
29	5, 10			
CA_4A-46A	4	5, 10, 15, 20	40	0
	46	20		

# FCC SAR Test Report

CA_5A-66A	5	5, 10	30	0
	66	5, 10, 15, 20		
CA_5A-66A-66A	5	5, 10	50	0
	66	Refer to CA_66A-66A (BCS0)		
CA_5A-66C	5	5, 10	50	0
	66	Refer to CA_66C (BCS0)		
CA_7A-12A	7	5, 10, 15, 20	30	0
	12	5, 10		
CA_12A-66A	12	5, 10	20	0
	66	1.4, 3, 5, 10		
	12	5, 10	30	1
	66	1.4, 3, 5, 10, 15, 20		
	12	3, 5, 10	30	2
	66	5, 10, 15, 20		
	12	5, 10	20	3
	66	5, 10		
	12	5, 10	30	4
	66	5, 10, 15, 20		
	12	5	20	5
66	5, 10, 15			
CA_13A-66A	13	5, 10	30	0
	66	5, 10, 15, 20		
CA_13A-66A-66A	13	5, 10	50	0
	66	Refer to CA_66A-66A (BCS0)		
CA_13A-66B	13	5, 10	30	0
	66	Refer to CA_66B (BCS0)		
CA_29A-66A	29	5, 10	30	0
	66	5, 10, 15, 20		

## LTE CA Configurations and Bandwidth Combination Sets defined for Inter-Band CA (Three Bands)

Downlink CA Configuration	LTE Bands	Channel Bandwidths for Carrier (MHz)	Maximum Aggregated Bandwidth (MHz)	Bandwidth Combination Set
CA_2A-4A-5A	2	5, 10, 15, 20	50	0
	4	5, 10, 15, 20		
	5	5, 10		
CA_2A-4A-7A	2	5, 10, 15, 20	60	0
	4	5, 10, 15, 20		
	7	5, 10, 15, 20		
CA_2A-4A-12A	2	5, 10, 15, 20	50	0
	4	5, 10, 15, 20		
	12	5, 10		
CA_2A-4A-13A	2	5, 10, 15, 20	50	0
	4	5, 10, 15, 20		
	13	10		
CA_2A-4A-29A	2	5, 10, 15, 20	50	0
	4	5, 10, 15, 20		
	29	5, 10		
CA_2A-13A-66A	2	5, 10, 15, 20	50	0
	13	5, 10		
	66	5, 10, 15, 20		
CA_4A-7A-12A	4	5, 10	40	0
	7	5, 10, 15, 20		
	12	5, 10		
	4	5, 10, 15, 20	50	1
	7	5, 10, 15, 20		
	12	5, 10		
	66	5, 10, 15, 20		



# FCC SAR Test Report

## <SAR Test Exclusion Evaluations for LTE Downlink CA>

According to Nov 2017 TCB Workshop, SAR test exclusion for LTE downlink Carrier Aggregation is determined by power measurements according to the number of component carriers (CCs) supported by the product implementation. The downlink Carrier Aggregation configurations are tabulated in separate columns. DL CA would be listed in the columns corresponding to Intra Band contiguous, Intra Band Non-contiguous, 2bands/2CCs, 2bands/3CCs, 3bands/3CCs. The CA/CC combinations in each columns are sorted so that frequency bands listed in subsequent columns on each row are ascending subsets, as following LTE Downlink CA table ; i.e., columns to the right correspond to increasing number of frequency bands and CCs.

	Intra Band		Inter Band		
	Contiguous	Non-Contiguous	2 Bands / 2CC	2 Bands / 3CC	3 Bands / 3CC
LTE Downlink CA-Configure	CA_2C	CA_2A-2A	CA_2A-4A	CA_2A-2A-5A	CA_2A-4A-5A
		CA_4A-4A	CA_4A-5A	CA_4A-4A-5A	
	CA_7B		CA_2A-7A	CA_2A-7A-7A	CA_2A-4A-7A
				CA_4A-7A-7A	
			CA_2A-12A	CA_2A-2A-12A	CA_2A-4A-12A
			CA_4A-12A	CA_4A-4A-12A	
			CA_2A-13A	CA_2A-2A-13A	CA_2A-4A-13A
			CA_4A-13A	CA_4A-4A-13A	
			CA_2A-29A		CA_2A-4A-29A
			CA_4A-29A		
			CA_2A-66A	CA_2A-66B	CA_2A-13A-66A
			CA_13A-66A	CA_2A-66C	
				CA_13A-66B	
				CA_2A-66A-66A	
			CA_4A-7A	CA_13A-66A-66A	CA_4A-7A-12A
	CA_7C		CA_7A-12A		
	CA_66B	CA_66A-66B	CA_5A-66A	CA_5A-66C	
	CA_66C	CA_66A-66C		CA_5A-66A-66A	
			CA_2A-46A		
			CA_4A-46A		
		CA_12A-66A			
		CA_66A-29A			
	CA_41D				

- Only yellow highlighted cells need power measurement.

**LTE Uplink Carrier Aggregation (CA) Setup Configurations**

This device supports LTE uplink CA for band 7 and 41 only with a maximum of two 20 MHz carrier components in the uplink. The maximum output power for uplink intra-band contiguous CA specified in Table 6.2.2A-1 of 3GPP TS 36.101 is the same as single carrier specified in Table 6.2.2-1 of 3GPP TS 36.101. In Table 6.2.3A-1 of 3GPP TS 36.101, the MPR (maximum power reduction) for several dB is allowed due to modulation and contiguously aggregated transmit bandwidth configuration. All the RF parameters in this device have followed above 3GPP criteria.

**LTE CA Configurations and Bandwidth Combination Sets defined for Intra-Band Contiguous CA**

Uplink CA Configuration	Component carriers in order of increasing carrier frequency			Maximum Aggregated Bandwidth (MHz)	Bandwidth Combination Set
	Channel bandwidths for carrier-1 (MHz)	Channel bandwidths for carrier-2 (MHz)	Channel bandwidths for carrier-3 (MHz)		
CA_7C	15	15		40	0
	20	20			
	10	20		40	1
	15	15, 20			
	20	10, 15, 20			
	15	10, 15		40	2
20	15, 20				
CA_41C	10	20	15	60	0
	10	15, 20	20		
	15	20	10, 15		
	15	10, 15, 20	20		
	20	15, 20	10		
	20	10, 15, 20	15, 20		

This device does not support full CA (Carrier Aggregation) features on 3GPP release 12. Its capability for LTE CA is for LTE band 41 only and supported configuration is shown in above. For network enhancement features, it does not support Wi-Fi Offloading, Enhanced SC-FDMA, Uplink MIMO, CoMP, HetNet, Relay, SON, Cross-Carrier Scheduling, eICIC, Enhanced Downlink MIMO, MBMS, M2M/D2D. All other uplink communications are identical to the LTE Release 8 specifications.

**<Considerations Related to WLAN for Setup and Testing>**

In general, various vendor specific external test software and chipset based internal test modes are typically used for SAR measurement. These chipset based test mode utilities are generally hardware and manufacturer dependent, and often include substantial flexibility to reconfigure or reprogram a device. A Wi-Fi device must be configured to transmit continuously at the required data rate, channel bandwidth and signal modulation, using the highest transmission duty factor supported by the test mode tools for SAR measurement. The test frequencies established using test mode must correspond to the actual channel frequencies. When 802.11 frame gaps are accounted for in the transmission, a maximum transmission duty factor of 92 - 96% is typically achievable in most test mode configurations. A minimum transmission duty factor of 85% is required to avoid certain hardware and device implementation issues related to wide range SAR scaling. In addition, a periodic transmission duty factor is required for current generation SAR systems to measure SAR correctly. The reported SAR must be scaled to 100% transmission duty factor to determine compliance at the maximum tune-up tolerance limit.

## FCC SAR Test Report

---

According to KDB 248227 D01, this device has installed WLAN engineering testing software which can provide continuous transmitting RF signal. During WLAN SAR testing, this device was operated to transmit continuously at the maximum transmission duty with specified transmission mode, operating frequency, lowest data rate, and maximum output power.

### Initial Test Configuration

An initial test configuration is determined for OFDM transmission modes in 2.4 GHz and 5 GHz bands according to the channel bandwidth, modulation and data rate combination(s) with the highest maximum output power specified for production units in each standalone and aggregated frequency band. When the same maximum power is specified for multiple transmission modes in a frequency band, the largest channel bandwidth, lowest order modulation, lowest data rate and lowest order 802.11a/g/n/ac mode is used for SAR measurement, on the highest measured output power channel in the initial test configuration, for each frequency band.

### Subsequent Test Configuration

SAR measurement requirements for the remaining 802.11 transmission mode configurations that have not been tested in the initial test configuration are determined separately for each standalone and aggregated frequency band, in each exposure condition, according to the maximum output power specified for production units. Additional power measurements may be required to determine if SAR measurements are required for subsequent highest output power channels in a subsequent test configuration. When the highest reported SAR for the initial test configuration according to the initial test position or fixed exposure position requirements, is adjusted by the ratio of the subsequent test configuration to initial test configuration specified maximum output power and the adjusted SAR is  $\leq 1.2$  W/kg, SAR is not required for that subsequent test configuration.

### SAR Test Configuration and Channel Selection

When multiple channel bandwidth configurations in a frequency band have the same specified maximum output power, the initial test configuration is using largest channel bandwidth, lowest order modulation, lowest data rate, and lowest order 802.11 mode (i.e., 802.11a is chosen over 802.11n then 802.11ac or 802.11g is chosen over 802.11n). After an initial test configuration is determined, if multiple test channels have the same measured maximum output power, the channel chosen for SAR measurement is determined according to the following.

- 1) The channel closest to mid-band frequency is selected for SAR measurement.
- 2) For channels with equal separation from mid-band frequency; for example, high and low channels or two mid-band channels, the higher frequency (number) channel is selected for SAR measurement.

## Test Reduction for U-NII-1 (5.2 GHz) and U-NII-2A (5.3 GHz) Bands

For devices that operate in both U-NII bands using the same transmitter and antenna(s), SAR test reduction is determined according to the following.

- 1) When the same maximum output power is specified for both bands, begin SAR measurement in U-NII-2A band by applying the OFDM SAR requirements. If the highest reported SAR for a test configuration is  $\leq 1.2$  W/kg, SAR is not required for U-NII-1 band for that configuration (802.11 mode and exposure condition).
- 2) When different maximum output power is specified for the bands, begin SAR measurement in the band with higher specified maximum output power. The highest reported SAR for the tested configuration is adjusted by the ratio of lower to higher specified maximum output power for the two bands. When the adjusted SAR is  $\leq 1.2$  W/kg, SAR is not required for the band with lower maximum output power in that test configuration.

### <Considerations Related to Bluetooth for Setup and Testing>

This device has installed Bluetooth engineering testing software which can provide continuous transmitting RF signal. During Bluetooth SAR testing, this device was operated to transmit continuously at the maximum transmission duty with specified transmission mode, operating frequency, lowest data rate, and maximum output power.

The Bluetooth call box has been used during SAR measurement and the EUT was set to DH5 mode at the maximum output power. Its duty factor was calculated as below and the measured SAR for Bluetooth would be scaled to the 100% transmission duty factor to determine compliance.

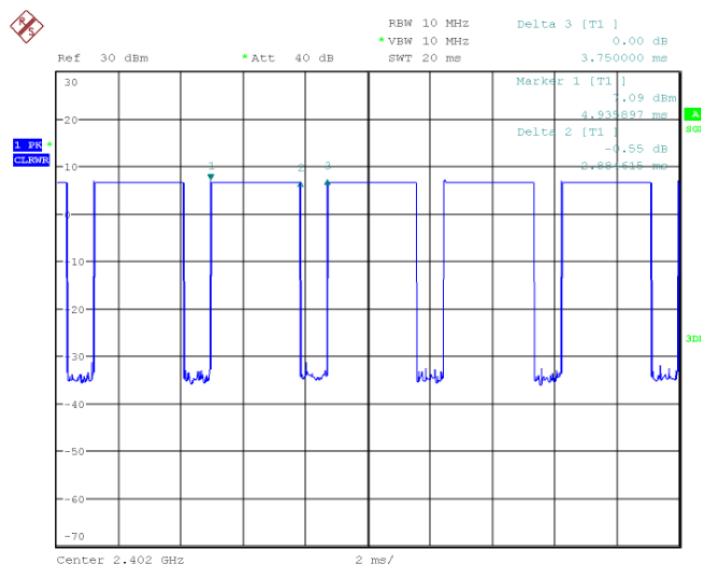

Date: 23.MAY.2019 19:08:35

**Time-domain plot for Bluetooth transmission signal**

The duty factor of Bluetooth signal has been calculated as following.

$$\text{Duty Factor} = \text{Pulse Width} / \text{Total Period} = 2.884615 / 3.75 = 76.9 \%$$

## 4.2 EUT Testing Position

This variant report is made for verification. The worst WWAN SAR configurations specified in the original SAR report was repeated and verified to ensure the device remains compliant, except tested WCDMA IV and LTE Band 66 completely.

### 4.2.1 Body Exposure Conditions

For laptop PC, according to KDB 616217 D04, SAR evaluation is required for the bottom surface of the keyboard. This EUT was tested in the base of EUT directly against the flat phantom. The required minimum test separation distance for incorporating transmitters and antennas into laptop computer display is determined with the display screen opened at an angle of 90° to the keyboard compartment.

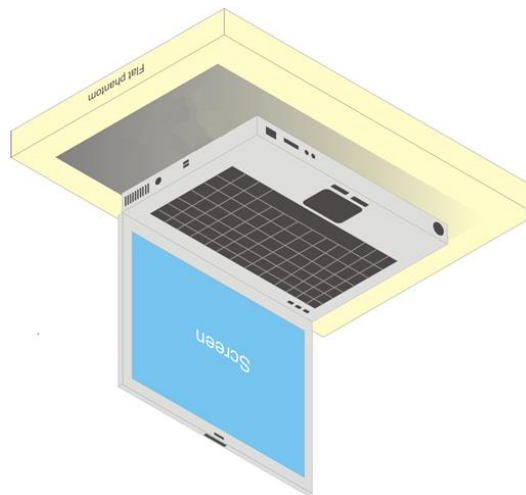

**Fig-4.1 Illustration for Laptop Setup**

## FCC SAR Test Report

For full-size tablet, according to KDB 616217 D04, SAR evaluation is required for back surface and edges of the devices. The back surface and edges of the tablet are tested with the tablet touching the phantom. Exposures from antennas through the front surface of the display section of a tablet are generally limited to the user's hands. Exposures to hands for typical consumer transmitters used in tablets are not expected to exceed the extremity SAR limit; therefore, SAR evaluation for the front surface of tablet display screens are generally not necessary. When voice mode is supported on a tablet and it is limited to speaker mode or headset operations only, additional SAR testing for this type of voice use is not required.

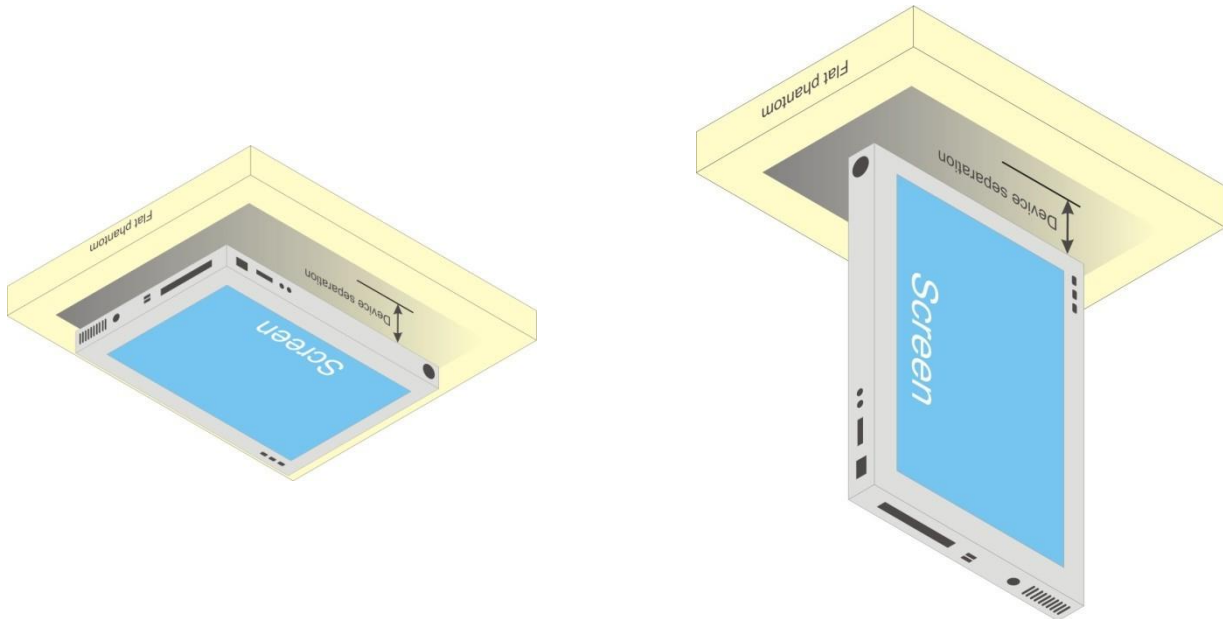

**Fig-4.2 Illustration for Tablet Setup**

# FCC SAR Test Report

## 4.2.2 SAR Test Exclusion Evaluations

According to KDB 447498 D01, the SAR test exclusion condition is based on source-based time-averaged maximum conducted output power, adjusted for tune-up tolerance, and the minimum test separation distance required for the exposure conditions. The SAR exclusion threshold is determined by the following formula.

1. For the test separation distance  $\leq 50$  mm

$$\frac{\text{Max. Tune up Power}_{(mW)}}{\text{Min. Test Separation Distance}_{(mm)}} \times \sqrt{f_{(GHz)}} \leq 3.0 \text{ for SAR-1g, } \leq 7.5 \text{ for SAR-10g}$$

When the minimum test separation distance is  $< 5$  mm, a distance of 5 mm is applied to determine SAR test exclusion.

2. For the test separation distance  $> 50$  mm, and the frequency at 100 MHz to 1500 MHz

$$\left[ (\text{Threshold at 50 mm in Step 1}) + (\text{Test Separation Distance} - 50 \text{ mm}) \times \left( \frac{f_{(MHz)}}{150} \right) \right]_{(mW)}$$

3. For the test separation distance  $> 50$  mm, and the frequency at  $> 1500$  MHz to 6 GHz

$$[(\text{Threshold at 50 mm in Step 1}) + (\text{Test Separation Distance} - 50 \text{ mm}) \times 10]_{(mW)}$$

### Laptop PC Mode:

#### <For WLAN Ant-0>

Mode	Max. Tune-up Power (dBm)	Max. Tune-up Power (mW)	Body-Worn		
			Ant. to Surface (mm)	Calculated Result	Require SAR Testing?
WLAN 2.4G	23.5	224	183	1426 mW	No
WLAN 5.2G	21.5	141	183	1396 mW	No
WLAN 5.3G	21.5	141	183	1395 mW	No
WLAN 5.6G	21.5	141	183	1393 mW	No
WLAN 5.8G	22.0	158	183	1392 mW	No

#### <For WLAN Ant-1>

Mode	Max. Tune-up Power (dBm)	Max. Tune-up Power (mW)	Body-Worn		
			Ant. to Surface (mm)	Calculated Result	Require SAR Testing?
WLAN 2.4G	23.0	200	183	1426 mW	No
WLAN 5.2G	21.5	141	183	1396 mW	No
WLAN 5.3G	22.0	158	183	1395 mW	No
WLAN 5.6G	21.5	141	183	1393 mW	No
WLAN 5.8G	22.0	158	183	1392 mW	No
BT	10.5	11	183	1425 mW	No

# FCC SAR Test Report

## <For WLAN Ant-0 + Ant-1>

Mode	Max. Tune-up Power (dBm)	Max. Tune-up Power (mW)	Body-Worn		
			Ant. to Surface (mm)	Calculated Result	Require SAR Testing?
WLAN 2.4G	22.5	178	183	1426 mW	No
WLAN 5.2G	23.0	200	183	1396 mW	No
WLAN 5.3G	23.5	224	183	1395 mW	No
WLAN 5.6G	23.5	224	183	1393 mW	No
WLAN 5.8G	25.0	316	183	1392 mW	No

## Tablet PC Mode:

### <For WLAN Ant-0>

Mode	Max. Tune-up Power (dBm)	Max. Tune-up Power (mW)	Rear Face			Left Side			Right Side			Top Side		Bottom Side			
			Ant. to Surface (mm)	Calculated Result	Require SAR Testing?	Ant. to Surface (mm)	Calculated Result	Require SAR Testing?	Ant. to Surface (mm)	Calculated Result	Require SAR Testing?	Ant. to Surface (mm)	Calculated Result	Require SAR Testing?	Ant. to Surface (mm)	Calculated Result	Require SAR Testing?
WLAN 2.4G	23.5	224	5	70.29	Yes	2	70.29	Yes	283	2426 mW	No	68	276 mW	No	131	906 mW	No
WLAN 5.2G	21.5	141	5	64.55	Yes	2	64.55	Yes	283	2396 mW	No	68	246	No	131	876 mW	No
WLAN 5.3G	21.5	141	5	65.04	Yes	2	65.04	Yes	283	2395 mW	No	68	245 mW	No	131	875 mW	No
WLAN 5.6G	21.5	141	5	67.44	Yes	2	67.44	Yes	283	2393 mW	No	68	243 mW	No	131	873 mW	No
WLAN 5.8G	22.0	158	5	76.27	Yes	2	76.27	Yes	283	2392 mW	No	68	242 mW	No	131	872 mW	No

### <For WLAN Ant-1/BT>

Mode	Max. Tune-up Power (dBm)	Max. Tune-up Power (mW)	Rear Face			Left Side			Right Side			Top Side		Bottom Side			
			Ant. to Surface (mm)	Calculated Result	Require SAR Testing?	Ant. to Surface (mm)	Calculated Result	Require SAR Testing?	Ant. to Surface (mm)	Calculated Result	Require SAR Testing?	Ant. to Surface (mm)	Calculated Result	Require SAR Testing?	Ant. to Surface (mm)	Calculated Result	Require SAR Testing?
WLAN 2.4G	23.0	200	5	62.76	Yes	283	2426 mW	No	2	62.76	Yes	68	276 mW	No	131	906 mW	No
WLAN 5.2G	21.5	141	5	64.55	Yes	283	2396 mW	No	2	64.55	Yes	68	246 mW	No	131	876 mW	No
WLAN 5.3G	22.0	158	5	72.89	Yes	283	2395 mW	No	2	72.89	Yes	68	245 mW	No	131	875 mW	No
WLAN 5.6G	21.5	141	5	67.44	Yes	283	2393 mW	No	2	67.44	Yes	68	243 mW	No	131	873 mW	No
WLAN 5.8G	22.0	158	5	76.27	Yes	283	2392 mW	No	2	76.27	Yes	68	242 mW	No	131	872 mW	No
BT	10.5	11	5	3.46	Yes	283	2425 mW	No	2	3.46	Yes	68	275 mW	No	131	905 mW	No

### <For WLAN Ant-0 + Ant-1>

Mode	Max. Tune-up Power (dBm)	Max. Tune-up Power (mW)	Rear Face			Left Side			Right Side			Top Side		Bottom Side			
			Ant. to Surface (mm)	Calculated Result	Require SAR Testing?	Ant. to Surface (mm)	Calculated Result	Require SAR Testing?	Ant. to Surface (mm)	Calculated Result	Require SAR Testing?	Ant. to Surface (mm)	Calculated Result	Require SAR Testing?	Ant. to Surface (mm)	Calculated Result	Require SAR Testing?
WLAN 2.4G	22.5	178	5	55.86	Yes	2	55.86	Yes	2	55.86	Yes	68	276 mW	No	131	906 mW	No
WLAN 5.2G	23.0	200	5	91.56	Yes	2	91.56	Yes	2	91.56	Yes	68	246	No	131	876 mW	No
WLAN 5.3G	23.5	224	5	103.33	Yes	2	103.33	Yes	2	103.33	Yes	68	245 mW	No	131	875 mW	No
WLAN 5.6G	23.5	224	5	107.15	Yes	2	107.15	Yes	2	107.15	Yes	68	243 mW	No	131	873 mW	No
WLAN 5.8G	25.0	316	5	152.53	Yes	2	152.53	Yes	2	152.53	Yes	68	242 mW	No	131	872 mW	No



**4.3 Tissue Verification**

The measuring results for tissue simulating liquid are shown as below.

Test Date	Frequency (MHz)	Liquid Temp. (°C)	Measured Conductivity ( $\sigma$ )	Measured Permittivity ( $\epsilon_r$ )	Target Conductivity ( $\sigma$ )	Target Permittivity ( $\epsilon_r$ )	Conductivity Deviation (%)	Permittivity Deviation (%)
Jun. 20, 2019	750	23.5	0.891	42.928	0.89	41.9	0.11	2.45
Jun. 29, 2019	750	23.2	0.894	43.418	0.89	41.9	0.45	3.62
Jun. 19, 2019	835	23.1	0.901	42.636	0.9	41.5	0.11	2.74
Jun. 29, 2019	835	23.2	0.903	41.283	0.9	41.5	0.33	-0.52
Jun. 20, 2019	1750	23.3	1.328	40.136	1.37	40.1	-3.07	0.09
Jul. 03, 2019	1750	23.3	1.323	39.716	1.37	40.1	-3.43	-0.96
Jul. 08, 2019	1750	23.2	1.325	40.333	1.37	40.1	-3.28	0.58
Jun. 19, 2019	1900	23.2	1.456	38.805	1.4	40	4.00	-2.99
Jun. 27, 2019	1900	23.3	1.458	39.791	1.4	40	4.14	-0.52
Jun. 29, 2019	1900	23.2	1.455	39.708	1.4	40	3.93	-0.73
Jun. 26, 2019	2450	23.2	1.885	38.248	1.8	39.2	4.72	-2.43
Jun. 19, 2019	2600	23.1	2.035	38.57	1.96	39	3.83	-1.10
Jun. 29, 2019	2600	23.2	2.004	38.246	1.96	39	2.24	-1.93
Jul. 04, 2019	5250	23.4	4.741	36.971	4.71	35.9	0.66	2.98
Jun. 26, 2019	5600	23.2	4.897	35.581	5.07	35.5	-3.41	0.23
Jun. 27, 2019	5750	23.3	5.04	35.375	5.22	35.4	-3.45	-0.07

**Note:**

The dielectric properties of the tissue simulating liquid must be measured within 24 hours before the SAR testing and within  $\pm 5\%$  of the target values. Liquid temperature during the SAR testing must be within  $\pm 2$  °C.

**4.4 System Validation**

The SAR measurement system was validated according to procedures in KDB 865664 D01. The validation status in tabulated summary is as below.

Test Date	Probe S/N	Calibration Point	Measured Conductivity ( $\sigma$ )	Measured Permittivity ( $\epsilon_r$ )	Validation for CW			Validation for Modulation		
					Sensitivity Range	Probe Linearity	Probe Isotropy	Modulation Type	Duty Factor	PAR
Jun. 20, 2019	7375	750	0.891	42.928	Pass	Pass	Pass	N/A	N/A	N/A
Jun. 29, 2019	7375	750	0.894	43.418	Pass	Pass	Pass	N/A	N/A	N/A
Jun. 19, 2019	7375	835	0.901	42.636	Pass	Pass	Pass	N/A	N/A	N/A
Jun. 29, 2019	7375	835	0.903	41.283	Pass	Pass	Pass	N/A	N/A	N/A
Jun. 20, 2019	3971	1750	1.328	40.136	Pass	Pass	Pass	N/A	N/A	N/A
Jul. 03, 2019	7472	1750	1.323	39.716	Pass	Pass	Pass	N/A	N/A	N/A
Jul. 08, 2019	7375	1750	1.325	40.333	Pass	Pass	Pass	N/A	N/A	N/A
Jun. 19, 2019	7375	1900	1.456	38.805	Pass	Pass	Pass	N/A	N/A	N/A
Jun. 27, 2019	7375	1900	1.458	39.791	Pass	Pass	Pass	N/A	N/A	N/A
Jun. 29, 2019	7375	1900	1.455	39.708	Pass	Pass	Pass	N/A	N/A	N/A
Jun. 26, 2019	7375	2450	1.885	38.248	Pass	Pass	Pass	OFDM	N/A	Pass
Jun. 19, 2019	7375	2600	2.035	38.57	Pass	Pass	Pass	N/A	N/A	N/A
Jun. 29, 2019	7375	2600	2.004	38.246	Pass	Pass	Pass	N/A	N/A	N/A
Jul. 04, 2019	7472	5250	4.741	36.971	Pass	Pass	Pass	OFDM	N/A	Pass
Jun. 26, 2019	7375	5600	4.897	35.581	Pass	Pass	Pass	OFDM	N/A	Pass
Jun. 27, 2019	7375	5750	5.04	35.375	Pass	Pass	Pass	OFDM	N/A	Pass

# FCC SAR Test Report

## 4.5 System Verification

The measuring result for system verification is tabulated as below.

Test Date	Frequency (MHz)	1W Target SAR-1g (W/kg)	Measured SAR-1g (W/kg)	Normalized to 1W SAR-1g (W/kg)	Deviation (%)	Dipole S/N	Probe S/N	DAE S/N
Jun. 20, 2019	750	8.15	1.97	7.88	-3.31	1013	7375	916
Jun. 29, 2019	750	8.15	2.08	8.32	2.09	1013	7375	1277
Jun. 19, 2019	835	9.44	2.41	9.64	2.12	4d121	7375	916
Jun. 29, 2019	835	9.44	2.39	9.56	1.27	4d121	7375	1277
Jun. 20, 2019	1750	36.90	9.47	37.88	2.66	1055	3971	1431
Jul. 03, 2019	1750	36.90	9.17	36.68	-0.60	1055	7472	579
Jul. 08, 2019	1750	36.90	9.2	36.80	-0.27	1055	7375	1277
Jun. 19, 2019	1900	40.20	10.5	42.00	4.48	5d036	7375	916
Jun. 27, 2019	1900	40.20	10.4	41.60	3.48	5d036	7375	1277
Jun. 29, 2019	1900	40.20	10.1	40.40	0.50	5d036	7375	1277
Jun. 26, 2019	2450	51.50	13.5	54.00	4.85	737	7375	1277
Jun. 19, 2019	2600	55.70	13.7	54.80	-1.62	1020	7375	916
Jun. 29, 2019	2600	55.70	14.9	59.60	7.00	1020	7375	1277
Jul. 04, 2019	5250	80.70	7.74	77.40	-4.09	1019	7472	579
Jun. 26, 2019	5600	85.80	8.17	81.70	-4.78	1019	7375	1277
Jun. 27, 2019	5750	81.50	8.19	81.90	0.49	1019	7375	1277

### Note:

Comparing to the reference SAR value provided by SPEAG, the validation data should be within its specification of 10 %. The result indicates the system check can meet the variation criterion and the plots can be referred to Appendix A of this report.

# FCC SAR Test Report

## 4.6 Maximum Output Power

### 4.6.1 Maximum Target Conducted Power

The maximum conducted average power (Unit: dBm) including tune-up tolerance is shown as below.

Mode	WCDMA Band II	WCDMA Band IV	WCDMA Band V
RMC 12.2K	19.5	20.5	20.0
HSDPA / HSUPA / DC-HSDPA	19.5	20.5	20.0

Mode	LTE 2	LTE 4	LTE 5	LTE 7
Maximum Target Power	19.5	21.5	21.0	17.0

Mode	LTE 12	LTE 13	LTE 14	LTE 26
Maximum Target Power	24.0	22.5	22.5	21.0

Mode	LTE 41	LTE 66
Maximum Target Power	19.0	21.5

### <WLAN 2.4G>

Mode	Channel	Frequency (MHz)	Ant-0	Ant-1	Ant-0 + Ant-1
802.11b	1	2412	19.0	18.5	-
	6	2437	21.5	21.0	-
	11	2462	18.5	18.5	-
	12	2467	17.0	17.0	-
	13	2472	16.5	15.5	-
802.11g	1	2412	17.5	17.5	-
	6	2437	22.0	21.5	-
	11	2462	17.5	17.5	-
	12	2467	15.5	15.0	-
	13	2472	-2.0	-2.5	-
802.11n (HT20)	1	2412	20.5	20.0	21.5
	6	2437	23.5	23.0	22.5
	11	2462	21.0	21.0	22.5
	12	2467	18.0	17.5	19.5
	13	2472	-3.0	-3.0	-2.0
802.11n (HT40)	3	2422	18.5	18.0	19.0
	6	2437	21.5	21.5	22.5
	9	2452	19.5	19.5	15.0
	10	2457	14.0	13.5	16.5
	11	2462	3.5	4.0	6.5

# FCC SAR Test Report

## <WLAN 5.2G>

Mode	Channel	Frequency (MHz)	Ant-0	Ant-1	Ant-0 + Ant-1
802.11a	36	5180	17.5	18.0	-
	40	5200	21.0	20.5	-
	44	5220	21.0	20.5	-
	48	5240	21.0	21.5	-
802.11n (HT20)	36	5180	17.0	17.5	20.5
	40	5200	20.0	20.5	22.0
	44	5220	20.0	20.5	22.5
	48	5240	21.5	21.0	23.0
802.11n (HT40)	38	5190	18.0	17.5	17.5
	46	5230	19.0	18.5	21.0
802.11ac (VHT80)	42	5210	17.0	17.5	20.5

## <WLAN 5.3G>

Mode	Channel	Frequency (MHz)	Ant-0	Ant-1	Ant-0 + Ant-1
802.11a	52	5260	21.5	22.0	-
	56	5280	21.0	21.5	-
	60	5300	21.0	21.5	-
	64	5320	17.5	17.0	-
802.11n (HT20)	52	5260	21.5	22.0	23.5
	56	5280	21.0	21.0	22.5
	60	5300	21.0	21.0	22.5
	64	5320	17.0	17.0	19.0
802.11n (HT40)	54	5270	18.5	18.5	20.0
	62	5310	15.5	15.5	17.5
802.11ac (VHT80)	58	5290	16.5	15.5	16.5
802.11ac (VHT160)	50	5250	12.5	13.0	12.5

## <WLAN 5.6G>

Mode	Channel	Frequency (MHz)	Ant-0	Ant-1	Ant-0 + Ant-1
802.11a	100	5500	18.5	18.0	-
	116	5580	21.5	21.5	-
	120	5600	21.0	21.5	-
	124	5620	21.0	21.5	-
	132	5660	21.0	21.0	-
	140	5700	19.0	19.0	-
802.11n (HT20)	100	5500	16.5	18.5	19.5
	116	5580	21.0	21.5	22.5
	120	5600	21.0	21.5	22.5
	124	5620	21.0	21.5	22.5
	132	5660	21.0	21.5	22.5
	140	5700	18.5	18.5	20.0
802.11n (HT40)	144	5720	20.0	20.0	22.0
	102	5510	17.0	17.5	19.5
	110	5550	21.0	21.5	23.5
	118	5590	21.0	21.5	23.0
	126	5630	21.0	21.5	23.0
	134	5670	18.5	19.0	19.5
802.11ac (VHT80)	142	5710	20.0	21.5	22.0
	106	5530	18.0	17.5	18.0
	122	5610	20.0	20.0	22.5
802.11ac (VHT160)	138	5690	21.0	21.0	23.0
	114	5570	15.0	14.5	15.5

# FCC SAR Test Report

## <WLAN 5.8G>

Mode	Channel	Frequency (MHz)	Ant-0	Ant-1	Ant-0 + Ant-1
802.11a	149	5745	22.0	21.5	-
	153	5765	22.0	21.5	-
	157	5785	21.0	22.0	-
	161	5805	21.5	21.5	-
	165	5825	21.5	21.5	-
802.11n (HT20)	149	5745	22.0	21.0	24.5
	153	5765	22.0	21.5	24.5
	157	5785	21.0	22.0	25.0
	161	5805	21.5	21.5	24.5
	165	5825	21.5	21.5	24.5
802.11n (HT40)	151	5755	19.5	21.5	21.5
	159	5795	20.0	20.0	23.0
802.11ac (VHT80)	155	5775	19.0	19.0	21.0

## <Bluetooth>

Mode	Channel	Frequency (MHz)	Tune-up
Bluetooth EDR	0	2402	9.5
	39	2441	10.0
	78	2480	10.5
Bluetooth LE	0	2402	8.0
	19	2440	8.5
	39	2480	8.5

### 4.6.2 Measured Conducted Power Result

The measuring conducted average power (Unit: dBm) is shown as below.

Band Channel	WCDMA Band II			WCDMA Band IV			WCDMA Band V			3GPP MPR (dB)
	9262	9400	9538	1312	1413	1513	4132	4182	4233	
Frequency (MHz)	1852.4	1880.0	1907.6	1712.4	1732.6	1752.6	826.4	836.4	846.6	
RMC 12.2K	<b>19.18</b>	19.11	19.10	<b>20.49</b>	20.47	20.44	19.81	<b>19.89</b>	19.73	-
HSDPA Subtest-1	18.17	18.21	18.08	20.06	20.06	20.07	18.76	18.84	18.68	0
HSDPA Subtest-2	18.14	18.17	18.05	20.17	19.75	20.08	18.68	18.76	18.60	0
HSDPA Subtest-3	17.64	17.63	17.55	19.48	19.54	19.59	18.19	18.27	18.11	0.5
HSDPA Subtest-4	17.63	17.69	17.22	19.59	19.55	19.63	18.23	18.31	18.15	0.5
DC-HSDPA Subtest-1	18.13	18.15	18.11	20.00	20.00	20.01	18.66	18.74	18.58	0
DC-HSDPA Subtest-2	18.14	18.13	18.05	20.11	19.69	20.02	18.61	18.69	18.53	0
DC-HSDPA Subtest-3	18.10	<b>18.19</b>	18.03	19.42	19.48	19.53	18.63	18.71	18.55	0.5
DC-HSDPA Subtest-4	18.03	18.06	18.01	19.53	19.49	19.57	18.68	<b>18.76</b>	18.60	0.5
HSUPA Subtest-1	18.18	18.21	18.13	20.00	19.95	20.30	18.71	18.79	18.63	0
HSUPA Subtest-2	16.14	16.21	16.20	18.01	18.03	17.96	16.73	16.81	16.65	2
HSUPA Subtest-3	17.14	17.18	17.11	19.02	18.98	19.05	17.76	17.84	17.68	1
HSUPA Subtest-4	16.22	16.23	16.16	18.14	18.02	17.99	16.78	16.86	16.70	2
HSUPA Subtest-5	18.00	18.20	18.00	20.00	19.80	20.00	18.73	18.81	18.65	0

# FCC SAR Test Report

LTE Band 2																	
BW	MCS Index	RB Size	RB Offset	Low	Mid	High	3GPP MPR (dB)	BW	MCS Index	RB Size	RB Offset	Low	Mid	High	3GPP MPR (dB)		
		Channel		18700	18900	19100				Channel		18675	18900	19125			
		Frequency (MHz)		1860.0	1880.0	1900.0				Frequency (MHz)		1857.5	1880.0	1902.5			
20M	QPSK	1	0	19.36	19.42	19.38	0	15M	QPSK	1	0	19.29	19.41	19.31	0		
		1	50	19.00	19.06	19.02	0			1	37	18.97	18.97	19.01	0		
		1	99	19.05	19.11	19.07	0			1	74	19.03	19.06	19.03	0		
		50	0	19.17	19.23	19.19	0			36	0	19.15	19.15	19.11	0		
		50	25	19.11	19.17	19.13	0			36	19	19.01	19.08	19.08	0		
		50	50	19.07	19.13	19.09	0			36	39	19.06	19.05	19.07	0		
	16QAM	100	0	19.13	19.19	19.15	0		75	0	19.07	19.16	19.13	0			
		1	0	19.29	19.39	19.30	0		16QAM	1	0	19.25	19.27	19.22	0		
		1	50	18.96	19.03	19.00	0			1	37	18.93	18.97	18.95	0		
		1	99	18.96	19.07	19.05	0			1	74	18.89	18.98	19.00	0		
		50	0	19.11	19.15	19.19	0			36	0	19.07	19.05	19.05	0		
		50	25	19.06	19.16	19.13	0			36	19	19.07	18.99	19.03	0		
	50	50	18.98	19.05	19.02	0	36			39	18.89	19.03	19.02	0			
	64QAM	100	0	19.03	19.14	19.05	0		75	0	18.99	19.06	19.05	0			
		1	0	19.33	19.39	19.35	0		64QAM	1	0	19.20	19.33	19.22	0		
		1	50	18.99	18.96	19.01	0			1	37	18.93	18.92	18.99	0		
		1	99	18.97	19.04	18.98	0			1	74	18.99	19.00	19.04	0		
		50	0	19.09	19.22	19.15	0			36	0	19.14	19.15	19.10	0		
		50	25	19.08	19.10	19.04	0			36	19	18.99	19.06	19.00	0		
	50	50	19.00	19.06	19.06	0	36			39	19.04	19.05	19.00	0			
	100	0	19.12	19.14	19.11	0	75		0	19.07	19.04	19.06	0				
	10M	QPSK	1	0	19.31	19.40	19.33		0	5M	QPSK	1	0	19.34	19.36	19.32	0
			1	24	18.93	19.02	18.96		0			1	12	18.98	19.01	18.99	0
			1	49	19.02	19.10	18.99		0			1	24	19.01	19.01	19.07	0
25			0	19.15	19.18	19.09	0	12	0			19.16	19.16	19.15	0		
25			12	19.10	19.12	19.09	0	12	6			19.09	19.08	19.08	0		
25			25	18.97	19.11	19.06	0	12	13			18.97	19.05	19.00	0		
16QAM		50	0	19.08	19.17	19.10	0	25	0		19.03	19.19	19.14	0			
		1	0	19.16	19.35	19.27	0	16QAM	1		0	19.29	19.29	19.22	0		
		1	24	18.93	18.93	18.95	0		1		12	19.00	18.90	18.94	0		
		1	49	19.02	18.95	18.97	0		1		24	18.97	18.94	18.96	0		
		25	0	19.02	19.20	19.14	0		12		0	19.07	19.13	19.09	0		
		25	12	19.07	19.12	19.07	0		12		6	18.94	19.05	19.03	0		
25		25	19.01	19.08	18.98	0	12		13		19.01	18.97	18.98	0			
64QAM		50	0	19.00	19.02	19.04	0	25	0		19.10	19.09	19.06	0			
		1	0	19.23	19.31	19.30	0	64QAM	1		0	19.23	19.33	19.24	0		
		1	24	18.96	18.91	18.93	0		1		12	18.92	18.96	18.90	0		
		1	49	18.96	19.04	19.02	0		1		24	18.97	19.05	18.97	0		
		25	0	19.05	19.08	19.12	0		12		0	19.09	19.06	19.09	0		
		25	12	18.96	18.99	19.07	0		12		6	19.05	18.99	19.07	0		
25		25	18.97	19.06	18.97	0	12		13		18.95	19.00	18.90	0			
50		0	19.03	19.04	19.06	0	25	0	19.01		19.07	18.98	0				
3M		QPSK	1	0	19.34	19.42	19.35	0	1.4M		QPSK	1	0	19.28	19.36	19.28	0
			1	7	18.97	19.01	18.97	0				1	2	18.98	19.06	18.96	0
			1	14	19.05	19.07	18.97	0				1	5	19.00	19.07	18.97	0
	8		0	19.12	19.22	19.09	0	3		0		19.08	19.17	19.12	0		
	8		3	19.05	19.17	19.07	0	3		1		19.08	19.17	19.10	0		
	8		7	19.07	19.12	19.02	0	3		3		19.06	19.10	18.99	0		
	16QAM	15	0	19.12	19.13	19.09	0	6		0	19.04	19.13	19.15	0			
		1	0	19.22	19.29	19.21	0	16QAM		1	0	19.28	19.27	19.37	0		
		1	7	18.91	18.95	18.84	0			1	2	18.86	18.90	18.90	0		
		1	14	18.91	19.07	18.92	0			1	5	18.86	18.93	18.98	0		
		8	0	19.07	19.21	19.03	0			3	0	19.13	19.17	19.14	0		
		8	3	18.98	19.05	19.02	0			3	1	19.03	19.07	19.05	0		
	8	7	18.90	19.03	18.92	0	3			3	18.90	19.00	19.00	0			
	64QAM	15	0	19.05	19.14	18.97	0	6		0	19.00	19.08	19.04	0			
		1	0	19.26	19.26	19.32	0	64QAM		1	0	19.32	19.36	19.19	0		
		1	7	18.98	19.03	18.87	0			1	2	18.89	19.04	18.88	0		
		1	14	18.92	19.04	18.98	0			1	5	18.98	19.07	18.91	0		
		8	0	19.12	19.15	19.06	0			3	0	19.12	19.17	19.13	0		
		8	3	19.09	19.13	18.94	0			3	1	19.05	19.07	19.02	0		
	8	7	18.93	19.10	19.01	0	3			3	19.02	19.02	18.94	0			
	15	0	19.05	19.12	19.06	0	6	0		19.05	19.10	19.04	0				

# FCC SAR Test Report

LTE Band 4															
BW	MCS Index	RB Size	RB Offset	Low	Mid	High	3GPP MPR (dB)	BW	MCS Index	RB Size	RB Offset	Low	Mid	High	3GPP MPR (dB)
		Channel		20050	20175	20300				Channel		20025	20175	20325	
		Frequency (MHz)		1720.0	1732.5	1745.0				Frequency (MHz)		1717.5	1732.5	1747.5	
20M	QPSK	1	0	21.15	21.27	21.40	0	15M	QPSK	1	0	21.14	21.20	21.33	0
		1	50	21.11	21.22	21.40	0			1	37	21.06	21.12	21.35	0
		1	99	21.09	21.17	21.30	0			1	74	21.01	21.15	21.20	0
		50	0	21.07	21.19	21.36	0			36	0	21.03	21.11	21.29	0
		50	25	21.03	21.18	21.35	0			36	19	20.94	21.14	21.25	0
		50	50	21.00	21.11	21.25	0			36	39	20.99	21.01	21.20	0
	100	0	21.15	21.17	21.31	0	75		0	21.12	21.11	21.23	0		
	16QAM	1	0	21.13	21.25	21.36	0		1	0	21.08	21.14	21.30	0	
		1	50	21.08	21.21	21.36	0		1	37	21.09	21.13	21.26	0	
		1	99	21.04	21.17	21.20	0		1	74	21.02	21.05	21.21	0	
		50	0	21.07	21.09	21.36	0		36	0	20.95	21.04	21.22	0	
		50	25	20.93	21.17	21.31	0		36	19	20.91	21.10	21.26	0	
		50	50	20.98	21.08	21.16	0		36	39	20.95	21.08	21.23	0	
	100	0	21.08	21.10	21.25	0	75		0	21.14	21.06	21.19	0		
	64QAM	1	0	21.14	21.21	21.38	0		1	0	21.14	21.12	21.32	0	
		1	50	21.03	21.15	21.37	0		1	37	21.03	21.11	21.35	0	
		1	99	21.07	21.11	21.22	0		1	74	20.99	21.06	21.26	0	
		50	0	20.97	21.14	21.31	0		36	0	21.00	21.06	21.30	0	
50		25	20.94	21.13	21.34	0	36	19	20.94	21.06	21.18	0			
50		50	20.99	21.04	21.21	0	36	39	20.99	20.99	21.11	0			
100	0	21.05	21.12	21.24	0	75	0	20.96	21.07	21.13	0				
10M	QPSK	1	0	21.00	21.07	21.39	0	5M	QPSK	1	0	20.96	21.11	21.20	0
		1	24	20.97	21.15	21.26	0			1	12	21.02	21.06	21.15	0
		1	49	21.06	21.06	21.18	0			1	24	21.02	21.06	21.11	0
		25	0	21.00	21.03	21.21	0			12	0	20.94	21.01	21.16	0
		25	12	20.89	21.17	21.26	0			12	6	20.90	21.02	21.12	0
		25	25	20.82	20.96	21.13	0			12	13	20.85	20.94	21.04	0
	50	0	21.11	21.08	21.22	0	25		0	21.08	21.14	21.11	0		
	16QAM	1	0	21.03	21.09	21.23	0		1	0	21.02	21.18	21.26	0	
		1	24	20.92	20.94	21.29	0		1	12	20.99	20.95	21.20	0	
		1	49	20.80	20.87	21.19	0		1	24	20.93	20.98	21.21	0	
		25	0	20.92	21.02	21.17	0		12	0	20.90	21.01	21.17	0	
		25	12	20.87	21.01	21.15	0		12	6	20.74	21.01	21.06	0	
		25	25	20.76	20.92	21.18	0		12	13	20.67	21.00	21.19	0	
	50	0	21.02	20.98	21.11	0	25		0	20.85	21.01	21.08	0		
	64QAM	1	0	20.90	20.99	21.18	0		1	0	21.03	21.06	21.26	0	
		1	24	20.96	20.93	21.18	0		1	12	20.92	21.05	21.16	0	
		1	49	20.92	21.02	21.07	0		1	24	20.91	21.01	21.23	0	
		25	0	20.85	20.94	21.10	0		12	0	20.90	21.07	21.18	0	
25		12	20.96	21.15	21.14	0	12	6	20.76	21.01	21.10	0			
25		25	20.80	20.98	21.15	0	12	13	20.83	20.86	21.01	0			
50	0	21.05	21.10	21.17	0	25	0	21.00	21.08	21.22	0				
3M	QPSK	1	0	20.90	21.13	21.21	0	1.4M	QPSK	1	0	21.00	21.22	21.27	0
		1	7	21.01	20.97	21.37	0			1	2	20.94	21.14	21.23	0
		1	14	21.03	21.11	21.10	0			1	5	20.98	21.03	21.06	0
		8	0	21.00	21.00	21.21	0			3	0	20.99	21.01	21.14	0
		8	3	20.91	21.07	21.32	0			3	1	20.87	20.96	21.29	0
		8	7	20.92	21.00	21.23	0			3	3	20.95	20.89	21.19	0
	15	0	21.01	21.03	21.27	0	6		0	21.12	21.03	21.21	0		
	16QAM	1	0	20.99	21.17	21.27	0		1	0	20.91	21.09	21.20	0	
		1	7	20.86	21.12	21.21	0		1	2	20.85	21.06	21.22	0	
		1	14	20.95	20.87	21.16	0		1	5	20.97	21.09	21.06	0	
		8	0	20.91	21.01	21.24	0		3	0	20.74	21.04	21.29	0	
		8	3	20.89	21.09	21.25	0		3	1	20.80	20.95	21.21	0	
		8	7	20.72	20.90	21.03	0		3	3	20.86	20.89	21.04	0	
	15	0	20.98	20.90	21.14	0	6		0	20.98	20.95	21.22	0		
	64QAM	1	0	21.00	21.21	21.26	0		1	0	21.07	21.08	21.27	0	
		1	7	20.91	20.90	21.32	0		1	2	20.95	20.99	21.25	0	
		1	14	20.93	21.07	21.14	0		1	5	21.02	21.03	21.05	0	
		8	0	20.85	21.04	21.12	0		3	0	20.89	21.15	21.23	0	
8		3	20.81	20.94	21.14	0	3	1	20.75	21.01	21.15	0			
8		7	20.79	21.01	20.98	0	3	3	20.72	21.02	21.02	0			
15	0	20.87	20.97	21.16	0	6	0	21.00	20.89	21.26	0				

# FCC SAR Test Report

LTE Band 5																	
BW	MCS Index	RB Size	RB Offset	Low	Mid	High	3GPP MPR (dB)	BW	MCS Index	RB Size	RB Offset	Low	Mid	High	3GPP MPR (dB)		
		Channel		20450	20525	20600				Channel		20425	20525	20625			
		Frequency (MHz)		829.0	836.5	844.0				Frequency (MHz)		826.5	836.5	846.5			
10M	QPSK	1	0	20.92	20.99	20.95	0	5M	QPSK	1	0	20.91	20.93	20.98	0		
		1	24	20.84	20.96	20.93	0			1	12	20.75	20.80	20.89	0		
		1	49	20.66	20.87	20.75	0			1	24	20.57	20.64	20.75	0		
		25	0	20.94	20.95	20.93	0			12	0	20.93	20.92	20.99	0		
		25	12	20.90	20.93	20.91	0			12	6	20.92	20.98	20.97	0		
		25	25	20.73	20.86	20.82	0			12	13	20.69	20.75	20.79	0		
	16QAM	50	0	20.87	20.97	20.96	0		25	0	20.83	20.87	20.94	0			
		1	0	20.84	20.90	20.89	0		16QAM	1	0	20.86	20.89	20.84	0		
		1	24	20.82	20.86	20.75	0			1	12	20.81	20.80	20.80	0		
		1	49	20.61	20.60	20.57	0			1	24	20.46	20.75	20.66	0		
		25	0	20.94	20.95	20.85	0			12	0	20.82	20.92	20.93	0		
		25	12	20.85	20.88	20.84	0			12	6	20.90	20.99	20.89	0		
	25	25	20.72	20.73	20.70	0	12			13	20.65	20.68	20.68	0			
	64QAM	50	0	20.83	20.87	20.80	0		25	0	20.70	20.93	20.91	0			
		1	0	20.87	20.85	20.86	0		64QAM	1	0	20.83	20.96	20.95	0		
		1	24	20.74	20.81	20.74	0			1	12	20.83	20.70	20.80	0		
		1	49	20.63	20.69	20.57	0			1	24	20.61	20.68	20.58	0		
		25	0	20.87	20.89	20.78	0			12	0	20.85	20.90	20.88	0		
		25	12	20.88	20.96	20.88	0			12	6	20.94	20.98	20.98	0		
	25	25	20.70	20.76	20.66	0	12			13	20.61	20.68	20.75	0			
	3M	QPSK	50	0	20.85	20.80	20.74		0	25	0	20.77	20.87	20.81	0		
3M			QPSK	1	0	20.84	20.93	20.93	0	1.4M	QPSK	1	0	20.91	20.94	20.94	0
				1	7	20.78	20.85	20.89	0			1	2	20.78	20.80	20.92	0
				1	14	20.63	20.70	20.72	0			1	5	20.65	20.70	20.71	0
				8	0	20.93	20.97	20.99	0			3	0	20.90	20.89	20.96	0
				8	3	20.84	20.90	20.97	0			3	1	20.92	20.73	20.98	0
		8		7	20.66	20.70	20.77	0	3			3	20.72	20.72	20.75	0	
		16QAM	15	0	20.83	20.89	20.96	0	6		0	20.82	20.90	20.92	0		
			16QAM	1	0	20.82	20.85	20.91	0		16QAM	1	0	20.75	20.90	20.91	0
				1	7	20.72	20.77	20.80	0			1	2	20.77	20.81	20.79	0
				1	14	20.59	20.60	20.56	0			1	5	20.53	20.61	20.69	0
				8	0	20.82	20.85	20.96	0			3	0	20.81	20.85	20.95	0
				8	3	20.80	20.90	20.93	0			3	1	20.82	20.83	20.95	0
		8		7	20.56	20.78	20.72	0	3			3	20.60	20.79	20.69	0	
		64QAM	15	0	20.76	20.85	20.83	0	6		0	20.78	20.80	20.84	0		
			64QAM	1	0	20.84	20.89	20.91	0		64QAM	1	0	20.74	20.87	20.95	0
				1	7	20.71	20.81	20.82	0			1	2	20.76	20.70	20.85	0
				1	14	20.55	20.75	20.69	0			1	5	20.56	20.65	20.72	0
				8	0	20.87	20.93	20.91	0			3	0	20.91	20.95	20.94	0
				8	3	20.86	20.87	20.93	0			3	1	20.90	20.97	20.89	0
		8		7	20.71	20.60	20.75	0	3			3	20.61	20.75	20.66	0	
	15	0	20.73	20.85	20.80	0	6	0	20.71		20.74	20.89	0				



# FCC SAR Test Report

LTE Band 7															
BW	MCS Index	RB Size	RB Offset	Low	Mid	High	3GPP MPR (dB)	BW	MCS Index	RB Size	RB Offset	Low	Mid	High	3GPP MPR (dB)
		Channel		20850	21100	21350				Channel		20825	21100	21375	
		Frequency (MHz)		2510.0	2535.0	2560.0				Frequency (MHz)		2507.5	2535.0	2562.5	
20M	QPSK	1	0	16.62	16.59	16.71	0	15M	QPSK	1	0	16.52	16.55	16.69	0
		1	50	16.48	16.45	16.57	0			1	37	16.38	16.39	16.50	0
		1	99	16.45	16.42	16.54	0			1	74	16.42	16.40	16.44	0
		50	0	16.61	16.58	16.70	0			36	0	16.52	16.54	16.63	0
		50	25	16.61	16.58	16.70	0			36	19	16.57	16.56	16.68	0
		50	50	16.56	16.53	16.65	0			36	39	16.48	16.43	16.62	0
	16QAM	100	0	16.60	16.57	16.69	0		75	0	16.58	16.50	16.62	0	
		1	0	16.53	16.52	16.69	0		1	0	16.57	16.47	16.62	0	
		1	50	16.48	16.45	16.47	0		1	37	16.39	16.33	16.41	0	
		1	99	16.41	16.34	16.49	0		1	74	16.37	16.30	16.49	0	
		50	0	16.56	16.57	16.68	0		36	0	16.55	16.41	16.61	0	
		50	25	16.57	16.53	16.66	0		36	19	16.53	16.51	16.55	0	
	64QAM	50	50	16.54	16.49	16.57	0		36	39	16.47	16.50	16.52	0	
		100	0	16.57	16.55	16.64	0		75	0	16.55	16.51	16.60	0	
		1	0	16.52	16.51	16.67	0		1	0	16.46	16.46	16.55	0	
		1	50	16.41	16.39	16.49	0		1	37	16.41	16.34	16.48	0	
		1	99	16.35	16.34	16.49	0		1	74	16.35	16.33	16.38	0	
		50	0	16.55	16.52	16.70	0		36	0	16.47	16.47	16.69	0	
	10M	QPSK	50	25	16.55	16.54	16.64		0	36	19	16.45	16.50	16.59	0
			50	50	16.51	16.43	16.59		0	36	39	16.45	16.39	16.48	0
			100	0	16.60	16.53	16.69		0	75	0	16.47	16.44	16.52	0
			1	0	16.61	16.55	16.67		0	1	0	16.53	16.53	16.67	0
			1	24	16.43	16.37	16.48		0	1	12	16.38	16.40	16.54	0
			1	49	16.40	16.42	16.51		0	1	24	16.41	16.34	16.44	0
16QAM		25	0	16.59	16.52	16.62	0	12	0	16.55	16.48	16.62	0		
		25	12	16.56	16.49	16.61	0	12	6	16.55	16.53	16.62	0		
		25	25	16.55	16.48	16.55	0	12	13	16.49	16.44	16.59	0		
		50	0	16.54	16.53	16.59	0	25	0	16.53	16.52	16.66	0		
		1	0	16.46	16.48	16.61	0	1	0	16.52	16.48	16.63	0		
		1	24	16.39	16.40	16.47	0	1	12	16.38	16.30	16.48	0		
64QAM		1	49	16.30	16.31	16.36	0	1	24	16.29	16.40	16.46	0		
		25	0	16.54	16.52	16.59	0	12	0	16.53	16.54	16.62	0		
		25	12	16.61	16.46	16.52	0	12	6	16.47	16.53	16.65	0		
		25	25	16.43	16.41	16.57	0	12	13	16.38	16.37	16.54	0		
		50	0	16.54	16.39	16.53	0	25	0	16.47	16.50	16.63	0		
		1	0	16.56	16.48	16.60	0	1	0	16.53	16.49	16.61	0		
16QAM		1	24	16.38	16.40	16.47	0	1	12	16.36	16.41	16.43	0		
		1	49	16.33	16.28	16.35	0	1	24	16.30	16.32	16.42	0		
		25	0	16.42	16.46	16.55	0	12	0	16.53	16.55	16.65	0		
		25	12	16.55	16.46	16.60	0	12	6	16.48	16.45	16.62	0		
		25	25	16.45	16.38	16.53	0	12	13	16.51	16.42	16.63	0		
		50	0	16.47	16.49	16.58	0	25	0	16.47	16.54	16.55	0		

# FCC SAR Test Report

## LTE Band 12

BW	MCS Index	RB Size	RB Offset	Low	Mid	High	3GPP MPR (dB)	BW	MCS Index	RB Size	RB Offset	Low	Mid	High	3GPP MPR (dB)
		Channel		23060	23095	23130				Channel		23035	23095	23155	
		Frequency (MHz)		704.0	707.5	711.0				Frequency (MHz)		701.5	707.5	713.5	
10M	QPSK	1	0	23.56	23.55	23.36	0	5M	QPSK	1	0	23.53	23.46	23.29	0
		1	24	23.50	23.49	23.30	0			1	12	23.46	23.41	23.24	0
		1	49	23.51	23.50	23.31	0			1	24	23.44	23.48	23.30	0
		25	0	22.54	22.53	22.34	1			12	0	22.48	22.47	22.32	1
		25	12	22.65	22.64	22.45	1			12	6	22.61	22.61	22.41	1
		25	25	22.60	22.59	22.40	1			12	13	22.58	22.51	22.37	1
	50	0	22.62	22.61	22.42	1	25		0	22.58	22.58	22.38	1		
	16QAM	1	0	22.54	22.45	22.31	1		16QAM	1	0	22.47	22.51	22.23	1
		1	24	22.46	22.49	22.23	1			1	12	22.48	22.44	22.19	1
		1	49	22.50	22.46	22.28	1			1	24	22.35	22.40	22.23	1
		25	0	21.47	21.45	21.26	2			12	0	21.37	21.50	21.24	2
		25	12	21.60	21.59	21.36	2			12	6	21.59	21.54	21.35	2
		25	25	21.50	21.52	21.38	2			12	13	21.50	21.46	21.28	2
	50	0	21.54	21.53	21.39	2	25		0	21.46	21.52	21.31	2		
	64QAM	1	0	21.49	21.50	21.32	2		64QAM	1	0	21.48	21.49	21.30	2
		1	24	21.45	21.41	21.22	2			1	12	21.43	21.45	21.25	2
		1	49	21.45	21.48	21.29	2			1	24	21.41	21.34	21.28	2
		25	0	20.45	20.48	20.34	3			12	0	20.38	20.44	20.17	3
		25	12	20.59	20.57	20.42	3			12	6	20.57	20.46	20.39	3
		25	25	20.57	20.58	20.36	3			12	13	20.56	20.43	20.35	3
	50	0	20.55	20.56	20.32	3	25		0	20.61	20.47	20.28	3		
BW	MCS Index	RB Size	RB Offset	Low	Mid	High	3GPP MPR (dB)	BW	MCS Index	RB Size	RB Offset	Low	Mid	High	3GPP MPR (dB)
		Channel		23025	23095	23165				Channel		23017	23095	23173	
		Frequency (MHz)		700.5	707.5	714.5				Frequency (MHz)		699.7	707.5	715.3	
3M	QPSK	1	0	23.39	23.45	23.28	0	1.4M	QPSK	1	0	23.50	23.47	23.20	0
		1	7	23.32	23.31	23.21	0			1	2	23.43	23.32	23.21	0
		1	14	23.36	23.35	23.20	0			1	5	23.36	23.39	23.25	0
		8	0	22.51	22.35	22.28	1			3	0	23.33	23.49	23.15	0
		8	3	22.57	22.61	22.31	1			3	1	23.44	23.46	23.26	0
		8	7	22.48	22.40	22.38	1			3	3	23.46	23.46	23.35	0
	15	0	22.42	22.48	22.25	1	6		0	22.56	22.38	22.40	1		
	16QAM	1	0	22.49	22.36	22.10	1		16QAM	1	0	22.47	22.42	22.07	1
		1	7	22.37	22.36	21.96	1			1	2	22.41	22.23	22.21	1
		1	14	22.26	22.22	22.25	1			1	5	22.43	22.30	22.09	1
		8	0	21.42	21.39	21.27	2			3	0	22.42	22.35	22.07	1
		8	3	21.41	21.40	21.24	2			3	1	22.45	22.51	22.17	1
		8	7	21.32	21.52	21.31	2			3	3	22.47	22.27	22.29	1
	15	0	21.33	21.46	21.23	2	6		0	21.47	21.56	21.35	2		
	64QAM	1	0	21.33	21.43	21.10	2		64QAM	1	0	21.25	21.31	21.19	2
		1	7	21.37	21.26	21.17	2			1	2	21.25	21.29	21.16	2
		1	14	21.40	21.24	21.08	2			1	5	21.29	21.27	21.04	2
		8	0	20.48	20.34	20.17	3			3	0	21.28	21.26	21.14	2
		8	3	20.42	20.43	20.33	3			3	1	21.48	21.51	21.20	2
		8	7	20.54	20.47	20.12	3			3	3	21.40	21.42	21.37	2
	15	0	20.37	20.39	20.30	3	6		0	20.54	20.52	20.19	3		

# FCC SAR Test Report

LTE Band 13															
BW	MCS Index	RB Size	RB Offset	Low	Mid	High	3GPP MPR (dB)	BW	MCS Index	RB Size	RB Offset	Low	Mid	High	3GPP MPR (dB)
		Channel		23230	Channel					23205	23230	23225			
		Frequency (MHz)		782.0	Frequency (MHz)					779.5	782.0	784.5			
10M	QPSK	1	0		22.13		0	5M	QPSK	1	0	22.04	22.11	22.08	0
		1	24		22.05		0			1	12	21.95	22.02	21.99	0
		1	49		21.95		0			1	24	21.83	21.90	21.87	0
		25	0		22.12		0			12	0	21.99	22.06	22.03	0
		25	12		22.11		0			12	6	21.97	22.04	22.01	0
		25	25		22.08		0			12	13	22.01	22.08	22.05	0
	50	0		22.11		0	25		0	22.00	22.07	22.04	0		
	16QAM	1	0		21.96		0		16QAM	1	0	21.84	21.91	21.88	0
		1	24		22.05		0			1	12	21.87	21.94	21.91	0
		1	49		21.87		0			1	24	21.82	21.89	21.86	0
		25	0		22.05		0			12	0	21.92	21.99	21.96	0
		25	12		22.04		0			12	6	21.92	21.99	21.96	0
		25	25		22.03		0			12	13	21.88	21.95	21.92	0
	50	0		22.06		0	25		0	21.98	22.05	22.02	0		
	64QAM	1	0		22.03		0		64QAM	1	0	21.90	21.97	21.94	0
		1	24		22.03		0			1	12	21.94	22.01	21.98	0
		1	49		21.93		0			1	24	21.80	21.87	21.84	0
		25	0		22.12		0			12	0	21.96	22.03	22.00	0
		25	12		22.10		0			12	6	21.87	21.94	21.91	0
		25	25		22.06		0			12	13	21.84	21.91	21.88	0
	50	0		22.01		0	25		0	21.99	22.06	22.03	0		

# FCC SAR Test Report

LTE Band 14															
BW	MCS Index	RB Size	RB Offset	Low	Mid	High	3GPP MPR (dB)	BW	MCS Index	RB Size	RB Offset	Low	Mid	High	3GPP MPR (dB)
		Channel								Channel					
		Frequency (MHz)								Frequency (MHz)					
10M	QPSK	1	0		22.27		0	5M	QPSK	1	0	22.14	22.17	22.08	0
		1	24		22.17		0			1	12	22.11	22.14	22.05	0
		1	49		22.22		0			1	24	22.12	22.15	22.06	0
		25	0		22.23		0			12	0	22.17	22.20	22.11	0
		25	12		22.22		0			12	6	22.16	22.19	22.10	0
		25	25		22.26		0			12	13	22.22	22.25	22.16	0
	50	0		22.23		0	25		0	22.12	22.15	22.06	0		
	16QAM	1	0		22.11		0		16QAM	1	0	22.05	22.08	21.99	0
		1	24		22.09		0			1	12	22.06	22.09	22.00	0
		1	49		22.19		0			1	24	22.04	22.07	21.98	0
		25	0		22.16		0			12	0	22.08	22.11	22.02	0
		25	12		22.12		0			12	6	22.14	22.17	22.08	0
		25	25		22.19		0			12	13	22.12	22.15	22.06	0
	50	0		22.13		0	25		0	22.11	22.14	22.05	0		
	64QAM	1	0		22.11		0		64QAM	1	0	21.99	22.02	21.93	0
		1	24		22.17		0			1	12	22.06	22.09	22.00	0
		1	49		22.19		0			1	24	22.15	22.18	22.09	0
		25	0		22.16		0			12	0	22.17	22.20	22.11	0
		25	12		22.15		0			12	6	22.07	22.10	22.01	0
		25	25		22.25		0			12	13	22.07	22.10	22.01	0
	50	0		22.20		0	25		0	22.05	22.08	21.99	0		

# FCC SAR Test Report

LTE Band 26																						
BW	MCS Index	RB Size	RB Offset	Low	Mid	High	3GPP MPR (dB)	BW	MCS Index	RB Size	RB Offset	Low	Mid	High	3GPP MPR (dB)							
		Channel		26765	26865	26965				Channel		26740	26865	26990								
		Frequency (MHz)		821.5	831.5	841.5				Frequency (MHz)		819.0	831.5	844.0								
15M	QPSK	1	0	20.93	20.96	20.92	0	10M	QPSK	1	0	20.63	20.73	20.70	0							
		1	37	20.89	20.93	20.89	0			1	24	20.69	20.72	20.66	0							
		1	74	20.85	20.88	20.84	0			1	49	20.58	20.58	20.60	0							
		36	0	20.86	20.89	20.85	0			25	0	20.60	20.60	20.63	0							
		36	19	20.89	20.92	20.90	0			25	12	20.67	20.66	20.67	0							
		36	39	20.84	20.87	20.83	0			25	25	20.57	20.60	20.63	0							
		75	0	20.88	20.91	20.87	0			50	0	20.65	20.65	20.67	0							
	16QAM	1	0	20.64	20.75	20.64	0		1	0	20.55	20.62	20.61	0								
		1	37	20.70	20.68	20.65	0		1	24	20.55	20.59	20.55	0								
		1	74	20.55	20.64	20.59	0		1	49	20.50	20.63	20.55	0								
		36	0	20.56	20.67	20.65	0		25	0	20.56	20.59	20.55	0								
		36	19	20.59	20.72	20.59	0		25	12	20.63	20.62	20.56	0								
		36	39	20.57	20.65	20.54	0		25	25	20.47	20.60	20.52	0								
		75	0	20.60	20.63	20.64	0		50	0	20.65	20.62	20.63	0								
	64QAM	1	0	20.72	20.69	20.69	0		1	0	20.53	20.63	20.63	0								
		1	37	20.63	20.69	20.62	0		1	24	20.69	20.56	20.58	0								
		1	74	20.65	20.65	20.58	0		1	49	20.53	20.55	20.58	0								
		36	0	20.62	20.59	20.56	0		25	0	20.61	20.57	20.55	0								
		36	19	20.63	20.65	20.58	0		25	12	20.58	20.60	20.53	0								
		36	39	20.61	20.62	20.56	0		25	25	20.60	20.65	20.57	0								
		75	0	20.59	20.66	20.67	0		50	0	20.68	20.67	20.65	0								
5M	QPSK	1	0	20.65	20.63	20.51	0	3M	QPSK	1	0	20.57	20.65	20.55	0							
		1	12	20.47	20.59	20.44	0			1	7	20.62	20.61	20.51	0							
		1	24	20.49	20.61	20.59	0			1	14	20.47	20.57	20.51	0							
		12	0	20.45	20.56	20.58	0			8	0	20.52	20.57	20.47	0							
		12	6	20.59	20.64	20.54	0			8	3	20.62	20.61	20.64	0							
		12	13	20.52	20.64	20.48	0			8	7	20.52	20.50	20.40	0							
		25	0	20.47	20.64	20.57	0			15	0	20.57	20.60	20.47	0							
	16QAM	1	0	20.52	20.49	20.57	0		1	0	20.61	20.56	20.52	0								
		1	12	20.46	20.45	20.44	0		1	7	20.50	20.65	20.50	0								
		1	24	20.48	20.59	20.48	0		1	14	20.47	20.56	20.45	0								
		12	0	20.61	20.52	20.54	0		8	0	20.35	20.62	20.45	0								
		12	6	20.54	20.52	20.45	0		8	3	20.51	20.53	20.45	0								
		12	13	20.54	20.42	20.50	0		8	7	20.49	20.62	20.52	0								
		25	0	20.51	20.58	20.47	0		15	0	20.56	20.58	20.53	0								
	64QAM	1	0	20.47	20.55	20.50	0		1	0	20.63	20.44	20.54	0								
		1	12	20.48	20.49	20.41	0		1	7	20.50	20.50	20.57	0								
		1	24	20.41	20.44	20.49	0		1	14	20.37	20.49	20.54	0								
		12	0	20.45	20.62	20.54	0		8	0	20.41	20.47	20.55	0								
		12	6	20.38	20.45	20.41	0		8	3	20.46	20.64	20.40	0								
		12	13	20.49	20.55	20.42	0		8	7	20.47	20.53	20.45	0								
		25	0	20.49	20.46	20.36	0		15	0	20.53	20.57	20.58	0								
1.4M	MCS Index	RB Size	RB Offset	Low	Mid	High	3GPP MPR (dB)	[REDACTED]														
		Channel		26697	26865	27033										Channel		26705	26865	27025		
		Frequency (MHz)		814.7	831.5	848.3										Frequency (MHz)		815.5	831.5	847.5		
	QPSK	1	0	20.56	20.58	20.60	0									QPSK	1	0	20.57	20.65	20.55	0
		1	2	20.59	20.57	20.54	0										1	7	20.62	20.61	20.51	0
		1	5	20.60	20.48	20.59	0										1	14	20.47	20.57	20.51	0
		3	0	20.52	20.53	20.49	0										8	0	20.52	20.57	20.47	0
		3	1	20.57	20.66	20.53	0										8	3	20.62	20.61	20.64	0
		3	3	20.57	20.56	20.54	0										8	7	20.52	20.50	20.40	0
		6	0	20.53	20.58	20.59	0										15	0	20.57	20.60	20.47	0
	16QAM	1	0	20.68	20.54	20.53	0									1	0	20.61	20.56	20.52	0	
		1	2	20.43	20.50	20.48	0									1	7	20.50	20.65	20.50	0	
		1	5	20.49	20.58	20.57	0									1	14	20.47	20.56	20.45	0	
		3	0	20.57	20.48	20.51	0									8	0	20.35	20.62	20.45	0	
		3	1	20.50	20.53	20.49	0									8	3	20.51	20.53	20.45	0	
		3	3	20.47	20.49	20.48	0									8	7	20.49	20.62	20.52	0	
		6	0	20.49	20.39	20.46	0									15	0	20.56	20.58	20.53	0	
	64QAM	1	0	20.57	20.58	20.59	0									1	0	20.63	20.44	20.54	0	
		1	2	20.60	20.49	20.54	0									1	7	20.50	20.50	20.57	0	
		1	5	20.49	20.43	20.56	0									1	14	20.37	20.49	20.54	0	
		3	0	20.44	20.61	20.37	0									8	0	20.41	20.47	20.55	0	
3		1	20.47	20.53	20.53	0	8	3	20.46	20.64	20.40	0										
3		3	20.34	20.43	20.38	0	8	7	20.47	20.53	20.45	0										
6		0	20.44	20.53	20.46	0	15	0	20.53	20.57	20.58	0										

# FCC SAR Test Report

## LTE Band 41

BW	MCS Index	RB Size	RB Offset	Low	Mid	Mid	Mid	High	3GPP MPR (dB)	BW	MCS Index	RB Size	RB Offset	Low	Mid	Mid	Mid	High	3GPP MPR (dB)		
		Channel		39750	40185	40620	41055	41490				Channel		39725	40173	40620	41068	41515			
		Frequency (MHz)		2506.0	2549.5	2593.0	2636.5	2680.0				Frequency (MHz)		2503.5	2548.3	2593.0	2637.8	2682.5			
20M	QPSK	1	0	18.41	18.39	18.38	18.29	18.88	0	15M	QPSK	1	0	18.36	18.30	18.37	18.20	18.82	0		
		1	50	18.34	18.32	18.31	18.22	18.81	0			1	37	18.27	18.27	18.21	18.20	18.75	0		
		1	99	18.29	18.27	18.26	18.17	18.76	0			1	74	18.28	18.22	18.26	18.15	18.71	0		
		50	0	18.40	18.38	18.37	18.28	18.87	0			36	0	18.36	18.30	18.27	18.28	18.81	0		
		50	25	18.38	18.36	18.35	18.26	18.85	0			36	19	18.33	18.36	18.31	18.22	18.79	0		
		50	50	18.34	18.32	18.31	18.22	18.81	0			36	39	18.29	18.23	18.23	18.18	18.80	0		
	100	0	18.37	18.35	18.34	18.25	18.84	0	75		0	18.33	18.26	18.29	18.22	18.82	0				
	16QAM	1	0	18.37	18.35	18.35	18.23	18.78	0		16QAM	1	0	18.37	18.37	18.37	18.28	18.81	0		
		1	50	18.26	18.31	18.27	18.21	18.71	0			1	37	18.28	18.26	18.28	18.15	18.72	0		
		1	99	18.26	18.27	18.20	18.15	18.76	0			1	74	18.27	18.20	18.22	18.09	18.72	0		
		50	0	18.33	18.33	18.33	18.28	18.79	0			36	0	18.36	18.33	18.37	18.19	18.83	0		
		50	25	18.31	18.33	18.32	18.26	18.77	0			36	19	18.37	18.29	18.29	18.21	18.78	0		
		50	50	18.32	18.29	18.26	18.22	18.80	0			36	39	18.27	18.27	18.23	18.22	18.72	0		
	100	0	18.36	18.27	18.26	18.20	18.80	0	75		0	18.37	18.25	18.32	18.19	18.83	0				
	64QAM	1	0	18.41	18.33	18.35	18.26	18.83	0		64QAM	1	0	18.41	18.39	18.34	18.24	18.78	0		
		1	50	18.33	18.32	18.26	18.14	18.77	0			1	37	18.29	18.32	18.23	18.21	18.80	0		
		1	99	18.27	18.23	18.22	18.15	18.75	0			1	74	18.29	18.22	18.25	18.10	18.72	0		
		50	0	18.30	18.31	18.35	18.19	18.87	0			36	0	18.35	18.29	18.30	18.20	18.77	0		
		50	25	18.28	18.31	18.25	18.22	18.80	0			36	19	18.33	18.31	18.26	18.24	18.84	0		
		50	50	18.30	18.32	18.21	18.21	18.77	0			36	39	18.28	18.22	18.29	18.19	18.74	0		
	100	0	18.34	18.32	18.25	18.16	18.80	0	75		0	18.27	18.33	18.31	18.22	18.75	0				
	BW	MCS Index	RB Size	RB Offset	Low	Mid	Mid	Mid	High		3GPP MPR (dB)	BW	MCS Index	RB Size	RB Offset	Low	Mid	Mid	Mid	High	3GPP MPR (dB)
			Channel		39700	40160	40620	41080	41540					Channel		39675	40148	40620	41093	41565	
			Frequency (MHz)		2501.0	2547.0	2593.0	2639.0	2685.0					Frequency (MHz)		2498.5	2545.8	2593.0	2640.3	2687.5	
10M	QPSK	1	0	18.37	18.38	18.37	18.28	18.82	0	5M	QPSK	1	0	18.37	18.39	18.33	18.21	18.79	0		
		1	24	18.27	18.29	18.25	18.14	18.81	0			1	12	18.33	18.32	18.30	18.15	18.78	0		
		1	49	18.25	18.23	18.16	18.13	18.69	0			1	24	18.20	18.25	18.26	18.15	18.66	0		
		25	0	18.31	18.31	18.37	18.28	18.86	0			12	0	18.33	18.35	18.32	18.26	18.85	0		
		25	12	18.34	18.31	18.29	18.16	18.75	0			12	6	18.35	18.28	18.34	18.17	18.77	0		
		25	25	18.29	18.27	18.24	18.12	18.78	0			12	13	18.34	18.31	18.21	18.18	18.77	0		
	50	0	18.32	18.26	18.33	18.15	18.81	0	25		0	18.34	18.29	18.25	18.16	18.80	0				
	16QAM	1	0	18.37	18.32	18.38	18.23	18.82	0		16QAM	1	0	18.36	18.29	18.34	18.29	18.84	0		
		1	24	18.32	18.28	18.21	18.15	18.79	0			1	12	18.32	18.32	18.29	18.12	18.78	0		
		1	49	18.26	18.18	18.23	18.09	18.74	0			1	24	18.25	18.19	18.24	18.17	18.76	0		
		25	0	18.30	18.32	18.31	18.18	18.83	0			12	0	18.35	18.30	18.32	18.22	18.80	0		
		25	12	18.32	18.36	18.31	18.19	18.79	0			12	6	18.36	18.31	18.28	18.21	18.82	0		
		25	25	18.28	18.29	18.22	18.16	18.73	0			12	13	18.33	18.32	18.27	18.18	18.75	0		
	50	0	18.33	18.33	18.34	18.15	18.83	0	25		0	18.31	18.28	18.32	18.17	18.80	0				
	64QAM	1	0	18.39	18.29	18.37	18.25	18.79	0		64QAM	1	0	18.31	18.31	18.34	18.21	18.79	0		
		1	24	18.27	18.28	18.21	18.12	18.73	0			1	12	18.26	18.25	18.23	18.17	18.73	0		
		1	49	18.20	18.26	18.22	18.10	18.66	0			1	24	18.19	18.27	18.25	18.15	18.67	0		
		25	0	18.32	18.37	18.27	18.22	18.77	0			12	0	18.33	18.37	18.33	18.19	18.82	0		
		25	12	18.34	18.27	18.35	18.25	18.78	0			12	6	18.28	18.26	18.27	18.19	18.76	0		
		25	25	18.29	18.32	18.22	18.17	18.72	0			12	13	18.34	18.31	18.27	18.20	18.72	0		
	50	0	18.30	18.35	18.26	18.25	18.81	0	25		0	18.30	18.27	18.29	18.25	18.75	0				

# FCC SAR Test Report

## LTE Band 66

BW	MCS Index	RB Size	RB Offset	Low	Mid	High	3GPP MPR (dB)	BW	MCS Index	RB Size	RB Offset	Low	Mid	High	3GPP MPR (dB)
				Channel	132072	132322						132572	Channel	132047	
		Frequency (MHz)	1720.0	1745.0	1770.0	Frequency (MHz)	1717.5			1745.0	1772.5				
20M	QPSK	1	0	21.49	21.47	21.45	0	15M	QPSK	1	0	21.48	21.39	21.35	0
		1	50	21.30	21.28	21.26	0			1	37	21.29	21.19	21.22	0
		1	99	21.02	21.00	20.98	0			1	74	21.00	21.00	20.89	0
		50	0	21.39	21.37	21.35	0			36	0	21.35	21.32	21.25	0
		50	25	21.38	21.36	21.34	0			36	19	21.38	21.31	21.30	0
		50	50	20.46	20.44	20.42	0			36	39	20.46	20.41	20.40	0
	100	0	21.31	21.29	21.27	0	75		0	21.25	21.22	21.26	0		
	16QAM	1	0	21.41	21.39	21.37	0		16QAM	1	0	21.31	21.39	21.36	0
		1	50	21.40	21.38	21.36	0			1	37	21.39	21.30	21.26	0
		1	99	21.37	21.35	21.33	0			1	74	21.29	21.26	21.27	0
		50	0	21.43	21.41	21.39	0			36	0	21.37	21.35	21.36	0
		50	25	21.39	21.37	21.35	0			36	19	21.33	21.29	21.29	0
		50	50	21.19	21.17	21.15	0			36	39	21.19	21.15	21.12	0
	100	0	21.39	21.37	21.35	0	75		0	21.39	21.37	21.29	0		
	64QAM	1	0	21.48	21.48	21.46	0		64QAM	1	0	21.38	21.44	21.37	0
		1	50	21.42	21.40	21.38	0			1	37	21.40	21.32	21.29	0
		1	99	21.34	21.32	21.30	0			1	74	21.30	21.32	21.23	0
		50	0	20.98	20.96	20.94	0			36	0	20.94	20.89	20.85	0
50		25	20.87	20.85	20.83	0	36	19		20.87	20.85	20.74	0		
50		50	20.73	20.71	20.69	0	36	39		20.72	20.67	20.59	0		
100	0	20.80	20.78	20.76	0	75	0	20.77	20.77	20.71	0				
10M	QPSK	1	0	21.46	21.42	21.39	0	5M	QPSK	1	0	21.32	21.29	21.10	0
		1	24	21.14	21.16	21.09	0			1	12	21.19	21.19	21.10	0
		1	49	20.92	20.86	20.77	0			1	24	20.85	20.89	20.89	0
		25	0	21.16	21.16	21.27	0			12	0	21.16	21.15	21.18	0
		25	12	21.28	21.15	21.29	0			12	6	21.14	21.36	21.26	0
		25	25	20.33	20.28	20.35	0			12	13	20.23	20.21	20.22	0
	50	0	21.09	21.14	21.08	0	25		0	21.13	21.16	21.02	0		
	16QAM	1	0	21.35	21.19	21.21	0		16QAM	1	0	21.37	21.30	21.30	0
		1	24	21.25	21.28	21.17	0			1	12	21.25	21.25	21.26	0
		1	49	21.22	21.29	21.20	0			1	24	21.26	21.22	21.12	0
		25	0	21.19	21.25	21.19	0			12	0	21.34	21.32	21.33	0
		25	12	21.20	21.28	21.28	0			12	6	21.37	21.32	21.30	0
		25	25	21.10	21.08	21.03	0			12	13	21.09	21.07	20.96	0
	50	0	21.21	21.22	21.27	0	25		0	21.32	21.21	21.15	0		
	64QAM	1	0	21.32	21.40	21.26	0		64QAM	1	0	21.38	21.34	21.35	0
		1	24	21.30	21.23	21.19	0			1	12	21.28	21.31	21.21	0
		1	49	21.19	21.24	21.23	0			1	24	21.13	21.18	21.25	0
		25	0	20.88	20.80	20.77	0			12	0	20.89	20.81	20.80	0
25		12	20.74	20.77	20.76	0	12	6		20.74	20.76	20.77	0		
25		25	20.52	20.50	20.62	0	12	13		20.55	20.56	20.67	0		
50	0	20.68	20.62	20.68	0	25	0	20.76	20.63	20.62	0				
3M	QPSK	1	0	21.31	21.36	21.23	0	1.4M	QPSK	1	0	21.33	21.29	21.34	0
		1	7	21.13	21.12	21.14	0			1	2	21.12	21.18	21.24	0
		1	14	20.96	20.87	20.87	0			1	5	20.91	20.88	20.89	0
		8	0	21.25	21.19	21.13	0			3	0	21.23	21.20	21.18	0
		8	3	21.33	21.27	21.25	0			3	1	21.31	21.23	21.11	0
		8	7	20.45	20.39	20.25	0			3	3	20.30	20.34	20.27	0
	15	0	21.24	21.21	21.26	0	6		0	21.21	21.07	21.12	0		
	16QAM	1	0	21.26	21.34	21.22	0		16QAM	1	0	21.22	21.32	21.23	0
		1	7	21.22	21.22	21.18	0			1	2	21.23	21.20	21.27	0
		1	14	21.24	21.20	21.22	0			1	5	21.26	21.29	21.31	0
		8	0	21.30	21.34	21.34	0			3	0	21.28	21.22	21.27	0
		8	3	21.22	21.20	21.16	0			3	1	21.33	21.28	21.27	0
		8	7	21.09	21.13	20.97	0			3	3	21.09	20.99	21.10	0
	15	0	21.33	21.20	21.10	0	6		0	21.21	21.22	21.19	0		
	64QAM	1	0	21.27	21.39	21.29	0		64QAM	1	0	21.29	21.40	21.34	0
		1	7	21.27	21.31	21.20	0			1	2	21.31	21.27	21.17	0
		1	14	21.20	21.31	21.14	0			1	5	21.15	21.10	21.19	0
		8	0	20.86	20.80	20.88	0			3	0	20.83	20.81	20.85	0
8		3	20.80	20.70	20.81	0	3	1		20.82	20.75	20.65	0		
8		7	20.62	20.58	20.67	0	3	3		20.72	20.65	20.51	0		
15	0	20.73	20.71	20.59	0	6	0	20.76	20.68	20.59	0				

# FCC SAR Test Report

## <WLAN 2.4G>

Mode	Channel	Frequency (MHz)	Average Power (Ant-0)	Average Power (Ant-1)	Average Power (Ant-0 + Ant-1)
802.11b	1	2412	18.52	18.43	-
	6	2437	21.04	20.91	-
	11	2462	18.42	18.32	-
	12	2467	16.67	16.56	-
	13	2472	16.00	15.31	-
802.11n (HT40)	3	2422	-	-	18.88
	6	2437	-	-	22.49
	9	2452	-	-	14.88
	10	2457	-	-	16.35
	11	2462	-	-	6.02

## <WLAN 5.3G>

Mode	Channel	Frequency (MHz)	Average Power (Ant-0)	Average Power (Ant-1)	Average Power (Ant-0 + Ant-1)
802.11a	52	5260	21.06	21.52	-
	56	5280	20.58	21.02	-
	60	5300	20.52	21.01	-
	64	5320	17.31	16.93	-
802.11n (HT20)	52	5260	-	21.52	23.21
	56	5280	-	20.99	22.38
	60	5300	-	20.94	22.32
	64	5320	-	16.89	18.96

## <WLAN 5.6G>

Mode	Channel	Frequency (MHz)	Average Power (Ant-0)	Average Power (Ant-1)	Average Power (Ant-0 + Ant-1)
802.11a	100	5500	18.33	-	-
	116	5580	21.05	-	-
	120	5600	21.00	-	-
	124	5620	20.94	-	-
	132	5660	20.95	-	-
	140	5700	18.76	-	-
802.11n (HT40)	102	5510	-	17.50	19.17
	110	5550	-	21.11	23.01
	118	5590	-	21.04	22.92
	126	5630	-	21.05	22.90
	134	5670	-	18.78	19.17
	142	5710	-	20.27	22.00

## <WLAN 5.8G>

Mode	Channel	Frequency (MHz)	Average Power (Ant-0)	Average Power (Ant-1)	Average Power (Ant-0 + Ant-1)
802.11a	149	5745	21.65	21.44	-
	153	5765	21.61	21.41	-
	157	5785	20.92	21.56	-
	161	5805	21.21	21.33	-
	165	5825	21.26	21.21	-
802.11n (HT20)	149	5745	-	-	24.09
	153	5765	-	-	24.29
	157	5785	-	-	24.51
	161	5805	-	-	24.27
	165	5825	-	-	24.18



## FCC SAR Test Report

---

### <Bluetooth>

Mode	Channel	Frequency (MHz)	Average Power
Bluetooth EDR	0	2402	9.36
	39	2441	9.89
	78	2480	10.35
Bluetooth LE	0	2402	7.82
	19	2440	8.24
	39	2480	8.48

## 4.7 SAR Testing Results

### 4.7.1 SAR Test Reduction Considerations

#### <KDB 447498 D01, General RF Exposure Guidance>

Testing of other required channels within the operating mode of a frequency band is not required when the reported SAR for the mid-band or highest output power channel is:

- (1)  $\leq 0.8$  W/kg or 2.0 W/kg, for 1-g or 10-g respectively, when the transmission band is  $\leq 100$  MHz
- (2)  $\leq 0.6$  W/kg or 1.5 W/kg, for 1-g or 10-g respectively, when the transmission band is between 100 MHz and 200 MHz
- (3)  $\leq 0.4$  W/kg or 1.0 W/kg, for 1-g or 10-g respectively, when the transmission band is  $\geq 200$  MHz

When SAR is not measured at the maximum power level allowed for production units, the measured SAR will be scaled to the maximum tune-up tolerance limit to determine compliance. The scaling factor for the tune-up power is defined as maximum tune-up limit (mW) / measured conducted power (mW). The reported SAR would be calculated by measured SAR x tune-up power scaling factor.

The SAR has been measured with highest transmission duty factor supported by the test mode tools for WLAN and/or Bluetooth. When the transmission duty factor could not achieve 100%, the reported SAR will be scaled to 100% transmission duty factor to determine compliance at the maximum tune-up power. The scaling factor for the duty factor is defined as 100% / transmission duty cycle (%). The reported SAR would be calculated by measured SAR x tune-up power scaling factor x duty cycle scaling factor.

#### <KDB 941225 D01, 3G SAR Measurement Procedures>

The mode tested for SAR is referred to as the primary mode. The equivalent modes considered for SAR test reduction are denoted as secondary modes. Both primary and secondary modes must be in the same frequency band. When the maximum output power and tune-up tolerance specified for production units in a secondary mode is  $\leq 1/4$  dB higher than the primary mode or when the highest reported SAR of the primary mode is scaled by the ratio of specified maximum output power and tune-up tolerance of secondary to primary mode and the adjusted SAR is  $\leq 1.2$  W/kg, SAR measurement is not required for the secondary mode.

#### <KDB 941225 D05, SAR Evaluation Considerations for LTE Devices>

- (1) QPSK with 1 RB and 50% RB allocation

Start with the largest channel bandwidth and measure SAR, using the RB offset and required test channel combination with the highest maximum output power among RB offsets at the upper edge, middle and lower edge of each required test channel. When the reported SAR is  $\leq 0.8$  W/kg, testing of the remaining RB offset configurations and required test channels is not required; otherwise, SAR is required for the remaining required test channels and only for the RB offset configuration with the highest output power for that channel. When the reported SAR of a required test channel is  $> 1.45$  W/kg, SAR is required for all three RB offset configurations for that required test channel.

# FCC SAR Test Report

## (2) QPSK with 100% RB allocation

SAR is not required when the highest maximum output power for 100% RB allocation is less than the highest maximum output power in 50% and 1 RB allocations and the highest reported SAR for 1 RB and 50% RB allocation are  $\leq 0.8$  W/kg. Otherwise, SAR is measured for the highest output power channel; and if the reported SAR is  $> 1.45$  W/kg, the remaining required test channels must also be tested.

## (3) Higher order modulations

SAR is required only when the highest maximum output power for the configuration in the higher order modulation is  $> 1/2$  dB higher than the same configuration in QPSK or when the reported SAR for the QPSK configuration is  $> 1.45$  W/kg.

## (4) Other channel bandwidth

SAR is required when the highest maximum output power of the smaller channel bandwidth is  $> 1/2$  dB higher than the equivalent channel configurations in the largest channel bandwidth configuration or the reported SAR of a configuration for the largest channel bandwidth is  $> 1.45$  W/kg.

### <Power Confirmation for SAR Test Exclusion for LTE Downlink CA>

According to KDB 941225 D05A, the uplink maximum output power below was measured with downlink CA active on the channel with highest measured maximum output power when downlink CA is inactive. The downlink SCC channel was paired with the uplink channel as normal operation. For intra-band contiguous CA, the downlink channel spacing between the component carriers was set to multiple of 300 kHz less than the nominal channel spacing per section 5.4.1A of 3GPP TS36.521. For intra-band non-contiguous CA, the downlink channel spacing between the component carriers was set to maximum separation from PCC and remain fully within the downlink transmission band. For Inter-band CA, the SCC downlink channel was set to near the middle of its transmission band.

### Power Measurements Laptop Mode for Intra-Band Contiguous Downlink CA

CA Combination	PCC								SCC1				SCC2				Power	
	LTE Band	BW (MHz)	UL Ch	UL Freq. (MHz)	RB Size	RB Offset	DL Ch	DL Freq. (MHz)	LTE Band	BW (MHz)	DL Ch	DL Freq. (MHz)	LTE Band	BW (MHz)	DL Ch	DL Freq. (MHz)	Single Carrier Tx Power (dBm)	Tx Power with DL-CA Active (dBm)
CA_41D	41	20	41490	2680	1	0	41094	2640.4	41	20	41292	2660.2	41	20	41490	2680	18.88	18.72

### Power Measurements Laptop Mode for Inter-Band Contiguous Downlink CA(Two Band)

CA Combination	PCC								SCC1				Power	
	LTE Band	BW (MHz)	UL Ch	UL Freq. (MHz)	RB Size	RB Offset	DL Ch	DL Freq. (MHz)	LTE Band	BW (MHz)	DL Ch	DL Freq. (MHz)	Single Carrier Tx Power (dBm)	Tx Power with DL-CA Active (dBm)
CA_2A-46A	2	20	18900	1880	1	0	900	1960	46	20	50665	5537.5	19.42	19.40
CA_4A-46A	4	20	20300	1745	1	0	2300	2145	46	20	50665	5537.5	21.40	21.25
CA_12A-66A	12	10	23060	704	1	0	5060	734	66	20	66786	2145	23.56	23.46
CA_66A-29A	66	20	132322	1745	1	0	66786	2145	29	10	9715	722.5	21.30	21.23

# FCC SAR Test Report

## Power Measurements Laptop Mode for Inter-Band Contiguous Downlink CA(Three Band)

CA Combination	PCC								SCC1				SCC2				Power	
	LTE Band	BW (MHz)	UL Ch	UL Freq. (MHz)	RB Size	RB Offset	DL Ch	DL Freq. (MHz)	LTE Band	BW (MHz)	DL Ch	DL Freq. (MHz)	LTE Band	BW (MHz)	DL Ch	DL Freq. (MHz)	Single Carrier Tx Power (dBm)	Tx Power with DL-CA Active (dBm)
CA_2A-4A-5A	2	20	18900	1880	1	0	900	1960	4	20	2175	2132.5	5	10	2525	881.5	19.42	19.41
CA_2A-4A-7A	2	20	18900	1880	1	0	900	1960	4	20	2175	2132.5	7	20	3100	2655	19.42	19.39
CA_2A-4A-12A	2	20	18900	1880	1	0	900	1960	4	20	2175	2132.5	12	10	5095	737.5	19.42	19.40
CA_2A-4A-13A	2	20	18900	1880	1	0	900	1960	4	20	2175	2132.5	13	10	5230	751	19.42	19.38
CA_2A-4A-29A	2	20	18900	1880	1	0	900	1960	4	20	2175	2132.5	29	10	9715	722.5	19.42	19.22
CA_2A-13A-66A	2	20	18900	1880	1	0	900	1960	13	10	5230	751	66	20	66786	2145	19.42	19.35
CA_4A-7A-12A	4	20	20300	1745	1	0	2300	2145	7	20	3100	2655	12	10	5095	737.5	21.40	21.30
CA_5A-66C	5	10	20525	836.5	1	0	2525	881.5	66	20	66786	2145	66	20	66984	2164.8	20.99	20.79
CA_5A-66A-66A	5	10	20525	836.5	1	0	2525	881.5	66	20	66786	2145	66	20	67036	2170	20.99	20.85

### Summary for SAR Test Exclusion for LTE Downlink CA

Per power confirmation results in above, the uplink maximum output power with downlink CA active remains within the specified tune-up tolerance and not more than 0.25 dB higher than the maximum output power with downlink CA inactive. According to KDB 941225 D05A, the SAR test exclusion applies to LTE downlink CA operation.

### <Power Confirmation for SAR Testing for LTE Uplink CA>

The conducted power for uplink CA active was measured on the highest reported SAR configuration for each exposure condition with both two carrier components was set to largest channel bandwidth.

PCC							SCC							Power	
Band	BW (MHz)	Modulation	RB Size	RB Offset	UL Channel	UL Frequency (MHz)	Band	BW (MHz)	Modulation	RB Size	RB Offset	UL Channel	UL Frequency (MHz)	Single Carrier Tx Power (dBm)	Tx Power with UL-CA Active (dBm)
7	20	QPSK	1	0	20850	2510.0	7	20	QPSK	1	99	21048	2529.8	16.62	14.90
			1	99						16.45	16.42				
7	20	QPSK	1	0	21100	2535.0	7	20	QPSK	1	99	21298	2554.8	16.59	15.01
			1	99						16.42	16.36				
7	20	QPSK	1	0	21152	2540.2	7	20	QPSK	1	99	21350	2560.0	16.71	15.08
			1	99						16.54	16.39				
41	20	QPSK	1	0	39750	2506.0	41	20	QPSK	1	99	39948	2525.8	18.41	14.91
			1	99						18.29	18.27				
41	20	QPSK	1	0	40185	2549.5	41	20	QPSK	1	99	40383	2569.3	18.39	15.15
			1	99						18.27	18.22				
41	20	QPSK	1	0	40620	25930	41	20	QPSK	1	99	40818	2612.8	18.38	14.76
			1	99						18.26	18.23				
41	20	QPSK	1	0	41055	2636.5	41	20	QPSK	1	99	41253	2656.3	18.29	14.61
			1	99						18.17	18.06				
41	20	QPSK	1	0	41292	2660.2	41	20	QPSK	1	99	41490	2680.0	18.88	14.47
			1	99						18.76	18.37				

### SAR Measurements for Intra-Band Contiguous CA

The SAR testing was performed with the single carrier (uplink CA is inactive) for all test positions for each exposure condition. The LTE uplink CA active was verified with maximum output power on the highest SAR configuration of single carrier for each exposure condition. For intra-band contiguous CA, the SCC channel was set to closest available contiguous channel.

### <KDB 248227 D01, SAR Guidance for Wi-Fi Transmitters>

- (1) For handsets operating next to ear, hotspot mode or mini-tablet configurations, the initial test position procedures were applied. The test position with the highest extrapolated peak SAR will be used as the initial test position. When the reported SAR of initial test position is  $\leq 0.4$  W/kg, SAR testing for remaining test positions is not required. Otherwise, SAR is evaluated at the subsequent highest peak SAR positions until the reported SAR result is  $\leq 0.8$  W/kg or all test positions are measured.
- (2) For WLAN 2.4 GHz, the highest measured maximum output power channel for DSSS was selected for SAR measurement. When the reported SAR is  $\leq 0.8$  W/kg, no further SAR testing is required. Otherwise, SAR is evaluated at the next highest measured output power channel. When any reported SAR is  $> 1.2$  W/kg, SAR is required for the third channel. For OFDM modes (802.11g/n), SAR is not required when the highest reported SAR for DSSS is adjusted by the ratio of OFDM to DSSS specified maximum output power and it is  $\leq 1.2$  W/kg.
- (3) For WLAN 5 GHz, the initial test configuration was selected according to the transmission mode with the highest maximum output power. When the reported SAR of initial test configuration is  $> 0.8$  W/kg, SAR is required for the subsequent highest measured output power channel until the reported SAR result is  $\leq 1.2$  W/kg or all required channels are measured. For other transmission modes, SAR is not required when the highest reported SAR for initial test configuration is adjusted by the ratio of subsequent test configuration to initial test configuration specified maximum output power and it is  $\leq 1.2$  W/kg.
- (4) For WLAN MIMO mode, the power-based standalone SAR test exclusion or the sum of SAR provision in KDB 447498 to determine simultaneous transmission SAR test exclusion should be applied. Otherwise, SAR for MIMO mode will be measured with all applicable antennas transmitting simultaneously at the specified maximum output power of MIMO operation.

# FCC SAR Test Report

## 4.7.2 SAR Results for Body Exposure Condition (Test Separation Distance is 0 mm)

**Table PC Mode**

Plot No.	Band	Mode	Test Position	Ch.	EUT Config.	Max. Tune-up Power (dBm)	Measured Conducted Power (dBm)	Scaling Factor	Power Drift (dB)	Measured SAR-1g (W/kg)	Scaled SAR-1g (W/kg)
01	WCDMA II	RMC12.2K	Top Side	9262	SKU 2	19.5	19.18	1.08	-0.03	1.08	<b>1.17</b>
	WCDMA II	RMC12.2K	Top Side	9400	SKU 2	19.5	19.11	1.09	0.02	0.851	0.93
	WCDMA II	RMC12.2K	Top Side	9538	SKU 2	19.5	19.10	1.10	0.08	0.792	0.87
	WCDMA II	RMC12.2K	Right Side	9262	SKU 2	19.5	19.18	1.08	0.00	<0.001	0.00
	WCDMA II	RMC12.2K	Top Side	9262	SKU 2	19.5	19.18	1.08	0.02	1.03	1.11
	WCDMA IV	RMC12.2K	Rear Face	1312	SKU 2	20.5	20.49	1.00	0.00	<0.001	0.00
	WCDMA IV	RMC12.2K	Left Side	1312	SKU 2	20.5	20.49	1.00	0.03	0.132	0.13
	WCDMA IV	RMC12.2K	Right Side	1312	SKU 2	20.5	20.49	1.00	0.00	<0.001	0.00
02	WCDMA IV	RMC12.2K	Top Side	1312	SKU 2	20.5	20.49	1.00	0.18	1.08	<b>1.08</b>
	WCDMA IV	RMC12.2K	Top Side	1413	SKU 2	20.5	20.47	1.01	0.01	0.755	0.76
	WCDMA IV	RMC12.2K	Top Side	1513	SKU 2	20.5	20.44	1.01	0.11	0.741	0.75
	WCDMA IV	RMC12.2K	Top Side	1312	SKU 2	20.5	20.49	1.00	0.03	1.06	1.06
03	WCDMA V	RMC12.2K	Top Side	4233	SKU 2	20.0	19.73	1.06	-0.08	0.677	<b>0.72</b>
	WCDMA V	RMC12.2K	Right Side	4182	SKU 2	20.0	19.89	1.03	0.00	<0.001	0.00

**Note:**

1. The SAR testing above was verified based on the worst case of original report.
2. The "< 0.001" means there is no SAR value or the SAR is too low to be measured.

Plot No.	Band	Mode	Test Position	Ch.	RB#	RB Offset	EUT Config.	Max. Tune-up Power (dBm)	Measured Conducted Power (dBm)	Scaling Factor	Power Drift (dB)	Measured SAR-1g (W/kg)	Scaled SAR-1g (W/kg)
04	LTE2	QPSK20M	Top Side	18700	1	0	SKU 2	19.5	19.36	1.03	-0.05	1.07	<b>1.10</b>
	LTE2	QPSK20M	Top Side	18900	1	0	SKU 2	19.5	19.42	1.02	0.08	1.05	1.07
	LTE2	QPSK20M	Top Side	19100	1	0	SKU 2	19.5	19.38	1.03	0.01	1.01	1.04
	LTE2	QPSK20M	Right Side	18900	1	0	SKU 2	19.5	19.42	1.02	0.00	<0.001	0.00
	LTE2	QPSK20M	Right Side	18900	50	0	SKU 2	19.5	19.23	1.06	0.00	<0.001	0.00
	LTE2	QPSK20M	Top Side	18700	1	0	SKU 2	19.5	19.36	1.03	0.05	1.01	1.04
05	LTE7	QPSK20M	Top Side	20850	1	0	SKU 2	17.0	16.62	1.09	-0.04	0.717	<b>0.78</b>
	LTE7	QPSK20M	Right Side	21350	1	0	SKU 2	17.0	16.71	1.07	0.00	<0.001	0.00
	LTE7	QPSK20M	Right Side	21350	50	0	SKU 2	17.0	16.70	1.07	0.00	<0.001	0.00
06	LTE12	QPSK10M	Top Side	23060	1	0	SKU 2	24.0	23.56	1.11	-0.15	0.758	<b>0.84</b>
	LTE12	QPSK10M	Top Side	23095	1	0	SKU 2	24.0	23.55	1.11	0.08	0.732	0.81
	LTE12	QPSK10M	Top Side	23130	1	0	SKU 2	24.0	23.36	1.16	-0.02	0.711	0.82
	LTE12	QPSK10M	Right Side	23060	1	0	SKU 2	24.0	23.56	1.11	0.00	<0.001	0.00
	LTE12	QPSK10M	Right Side	23060	25	12	SKU 2	23.0	22.65	1.08	0.00	<0.001	0.00
07	LTE13	QPSK10M	Top Side	23230	1	0	SKU 2	22.5	22.13	1.09	-0.07	0.900	<b>0.98</b>
	LTE13	QPSK10M	Right Side	23230	1	0	SKU 2	22.5	22.13	1.09	0.00	<0.001	0.00
	LTE13	QPSK10M	Right Side	23230	25	0	SKU 2	22.5	22.12	1.09	0.00	<0.001	0.00
	LTE13	QPSK10M	Top Side	23230	1	0	SKU 2	22.5	22.13	1.09	0.02	0.888	0.97
08	LTE14	QPSK10M	Top Side	23330	25	25	SKU 2	22.5	22.26	1.06	-0.02	0.837	<b>0.89</b>
	LTE14	QPSK10M	Right Side	23330	1	0	SKU 2	22.5	22.27	1.05	0.00	<0.001	0.00
	LTE14	QPSK10M	Right Side	23330	25	25	SKU 2	22.5	22.26	1.06	0.00	<0.001	0.00
	LTE14	QPSK10M	Top Side	23330	25	25	SKU 2	22.5	22.26	1.06	0.02	0.811	0.86

**Note:**

1. The SAR testing above was verified based on the worst case of original report.
2. The "< 0.001" means there is no SAR value or the SAR is too low to be measured.

# FCC SAR Test Report

Plot No.	Band	Mode	Test Position	Ch.	RB#	RB Offset	EUT Config.	Max. Tune-up Power (dBm)	Measured Conducted Power (dBm)	Scaling Factor	Power Drift (dB)	Measured SAR-1g (W/kg)	Scaled SAR-1g (W/kg)
09	LTE26	QPSK15M	Top Side	26965	36	19	SKU 2	21.0	20.90	1.02	-0.06	0.789	<b>0.80</b>
	LTE26	QPSK15M	Top Side	26765	36	19	SKU 2	21.0	20.89	1.03	0.01	0.732	0.75
	LTE26	QPSK15M	Top Side	26865	36	19	SKU 2	21.0	20.92	1.02	-0.05	0.743	0.76
	LTE26	QPSK10M	Right Side	26865	1	0	SKU 2	21.0	20.96	1.01	0.00	<0.001	0.00
	LTE26	QPSK10M	Right Side	26865	36	19	SKU 2	21.0	20.92	1.02	0.00	<0.001	0.00
10	LTE41	QPSK20M	Top Side	41490	1	0	SKU 2	19.0	18.88	1.03	-0.15	0.316	<b>0.33</b>
	LTE41	QPSK20M	Right Side	41490	1	0	SKU 2	19.0	18.88	1.03	0.00	<0.001	0.00
	LTE41	QPSK20M	Right Side	41490	50	0	SKU 2	19.0	18.87	1.03	0.00	<0.001	0.00
	LTE 66	QPSK20M	Rear Face	132072	1	0	SKU 2	21.5	21.49	1.00	0.05	0.056	0.06
	LTE 66	QPSK20M	Left Side	132072	1	0	SKU 2	21.5	21.49	1.00	0.14	0.144	0.14
	LTE 66	QPSK20M	Right Side	132072	1	0	SKU 2	21.5	21.49	1.00	0.00	<0.001	0.00
11	LTE 66	QPSK20M	Top Side	132072	1	0	SKU 2	21.5	21.49	1.00	-0.13	1.19	<b>1.19</b>
	LTE 66	QPSK20M	Rear Face	132072	50	0	SKU 2	21.5	21.39	1.03	0.02	0.053	0.05
	LTE 66	QPSK20M	Left Side	132072	50	0	SKU 2	21.5	21.39	1.03	0.09	0.128	0.13
	LTE 66	QPSK20M	Right Side	132072	50	0	SKU 2	21.5	21.39	1.03	0.00	<0.001	0.00
	LTE 66	QPSK20M	Top Side	132072	50	0	SKU 2	21.5	21.39	1.03	0.11	1.12	1.15
	LTE 66	QPSK20M	Top Side	132322	1	0	SKU 2	21.5	21.47	1.01	0.06	1.09	1.10
	LTE 66	QPSK20M	Top Side	132572	1	0	SKU 2	21.5	21.45	1.01	-0.13	1.1	1.11
	LTE 66	QPSK20M	Top Side	132322	50	0	SKU 2	21.5	21.37	1.03	0.05	1.06	1.09
	LTE 66	QPSK20M	Top Side	132572	50	0	SKU 2	21.5	21.35	1.04	0.02	1.03	1.07
	LTE 66	QPSK20M	Top Side	132072	100	0	SKU 2	21.5	21.31	1.04	0.09	1.06	1.10
	LTE 66	QPSK20M	Top Side	132072	1	0	SKU 2	21.5	21.49	1.00	0.01	1.15	1.15

**Note:**

1. The SAR testing above was verified based on the worst case of original report.
2. The "< 0.001" means there is no SAR value or the SAR is too low to be measured.

Plot No.	Band	Mode	Test Position	Ch.	EUT Config.	Tx Antenna	Duty Cycle	Crest Factor	Max. Tune-up Power (dBm)	Measured Conducted Power (dBm)	Scaling Factor	Power Drift (dB)	Measured SAR-1g (W/kg)	Scaled SAR-1g (W/kg)
	WLAN2.4G	802.11b	Rear Face	6	SKU 2	Ant 0	97.00	1.03	21.5	21.04	1.11	0.00	<0.001	0.00
	WLAN2.4G	802.11b	Left Side	6	SKU 2	Ant 0	97.00	1.03	21.5	21.04	1.11	-0.16	0.440	0.50
	WLAN2.4G	802.11b	Rear Face	6	SKU 2	Ant 1	97.00	1.03	21.0	20.91	1.02	0.00	<0.001	0.00
12	WLAN2.4G	802.11b	Right Side	6	SKU 2	Ant 1	97.00	1.03	21.0	20.91	1.02	0.13	0.573	<b>0.60</b>
	WLAN2.4G	802.11n HT40	Rear Face	6	SKU 2	Ant 0+1	83.70	1.19	22.5	22.49	1.00	0.00	0.001	0.00
	WLAN2.4G	802.11n HT40	Left Side	6	SKU 2	Ant 0+1	83.70	1.19	22.5	22.49	1.00	-0.19	0.366	0.44
	WLAN2.4G	802.11n HT40	Right Side	6	SKU 2	Ant 0+1	83.70	1.19	22.5	22.49	1.00	0.03	0.425	0.51
	WLAN2.4G	802.11b	Right Side	6	SKU 1	Ant 1	97.00	1.03	21.0	20.91	1.02	-0.14	0.552	0.58
	WLAN2.4G	802.11b	Right Side	6	SKU 3	Ant 1	97.00	1.03	21.0	20.91	1.02	-0.06	0.545	0.57

**Note:** The "< 0.001" means there is no SAR value or the SAR is too low to be measured.



# FCC SAR Test Report

Plot No.	Band	Mode	Test Position	Ch.	EUT Config.	Tx Antenna	Duty Cycle	Crest Factor	Max. Tune-up Power (dBm)	Measured Conducted Power (dBm)	Scaling Factor	Power Drift (dB)	Measured SAR-1g (W/kg)	Scaled SAR-1g (W/kg)
	WLAN5.3G	802.11a	Rear Face	52	SKU 2	Ant 0	84.50	1.18	21.5	21.06	1.11	0.00	<0.001	0.00
	WLAN5.3G	802.11a	Left Side	52	SKU 2	Ant 0	84.50	1.18	21.5	21.06	1.11	-0.01	0.75	0.98
	WLAN5.3G	802.11a	Rear Face	52	SKU 2	Ant 1	84.50	1.18	22.0	21.52	1.12	0.00	<0.001	0.00
	WLAN5.3G	802.11a	Right Side	52	SKU 2	Ant 1	84.50	1.18	22.0	21.52	1.12	-0.17	1.01	1.33
	WLAN5.3G	802.11n HT20	Rear Face	52	SKU 2	Ant 0+1	84.00	1.19	23.5	23.21	1.07	0.00	<0.001	0.00
	WLAN5.3G	802.11n HT20	Left Side	52	SKU 2	Ant 0+1	84.00	1.19	23.5	23.21	1.07	-0.19	0.623	0.79
	WLAN5.3G	802.11n HT20	Right Side	52	SKU 2	Ant 0+1	84.00	1.19	23.5	23.21	1.07	0.07	0.624	0.79
	WLAN5.3G	802.11a	Left Side	56	SKU 2	Ant 0	84.50	1.18	21.0	20.58	1.10	-0.01	0.633	0.82
	WLAN5.3G	802.11a	Right Side	56	SKU 2	Ant 1	84.50	1.18	21.5	21.02	1.12	-0.01	1.01	1.33
13	WLAN5.3G	802.11a	Right Side	60	SKU 2	Ant 1	84.50	1.18	21.5	21.01	1.12	-0.05	1.03	1.36
	WLAN5.3G	802.11a	Right Side	64	SKU 2	Ant 1	84.50	1.18	17.0	16.93	1.02	0.11	0.504	0.61
	WLAN5.3G	802.11n HT20	Right Side	52	SKU 2	Ant 1	84.00	1.19	22.0	21.52	1.12	0.13	0.901	1.20
	WLAN5.3G	802.11n HT20	Right Side	56	SKU 2	Ant 1	84.00	1.19	21.0	20.99	1.00	0.02	0.932	1.11
	WLAN5.3G	802.11a	Right Side	60	SKU 1	Ant 1	84.50	1.18	21.5	21.01	1.12	-0.10	0.899	1.19
	WLAN5.3G	802.11a	Right Side	52	SKU 1	Ant 1	84.50	1.18	22.0	21.52	1.12	0.02	0.883	1.17
	WLAN5.3G	802.11a	Right Side	60	SKU 3	Ant 1	84.50	1.18	21.5	21.01	1.12	0.03	0.894	1.18
	WLAN5.3G	802.11a	Right Side	52	SKU 3	Ant 1	84.50	1.18	22.0	21.52	1.12	0.13	0.886	1.17
	WLAN5.3G	802.11a	Right Side	60	SKU 2	Ant 1	84.50	1.18	21.5	21.01	1.12	0.02	0.995	1.31
	WLAN5.6G	802.11a	Rear Face	116	SKU 2	Ant 0	84.50	1.18	21.5	21.05	1.11	0.00	<0.001	0.00
	WLAN5.6G	802.11a	Left Side	116	SKU 2	Ant 0	84.50	1.18	21.5	21.05	1.11	0.19	0.533	0.70
	WLAN5.6G	802.11n HT40	Rear Face	110	SKU 2	Ant 1	84.00	1.19	21.5	21.11	1.09	0.00	<0.001	0.00
14	WLAN5.6G	802.11n HT40	Right Side	110	SKU 2	Ant 1	84.00	1.19	21.5	21.11	1.09	0.13	0.917	1.19
	WLAN5.6G	802.11n HT40	Rear Face	110	SKU 2	Ant 0+1	84.00	1.19	23.5	23.01	1.12	0.00	<0.001	0.00
	WLAN5.6G	802.11n HT40	Left Side	110	SKU 2	Ant 0+1	84.00	1.19	23.5	23.01	1.12	0.18	0.382	0.51
	WLAN5.6G	802.11n HT40	Right Side	110	SKU 2	Ant 0+1	84.00	1.19	23.5	23.01	1.12	-0.15	0.558	0.74
	WLAN5.6G	802.11n HT40	Right Side	126	SKU 2	Ant 1	84.00	1.19	21.5	21.05	1.11	-0.10	0.731	0.97
	WLAN5.6G	802.11n HT40	Right Side	110	SKU 1	Ant 1	84.00	1.19	21.5	21.11	1.09	0.14	0.877	1.14
	WLAN5.6G	802.11n HT40	Right Side	126	SKU 1	Ant 1	84.00	1.19	21.5	21.05	1.11	0.03	0.726	0.96
	WLAN5.6G	802.11n HT40	Right Side	110	SKU 3	Ant 1	84.00	1.19	21.5	21.11	1.09	0.06	0.888	1.15
	WLAN5.6G	802.11n HT40	Right Side	126	SKU 3	Ant 1	84.00	1.19	21.5	21.05	1.11	0.18	0.714	0.94
	WLAN5.6G	802.11n HT40	Right Side	110	SKU 2	Ant 1	84.00	1.19	21.5	21.11	1.09	0.02	0.911	1.18
	WLAN5.8G	802.11a	Rear Face	149	SKU 2	Ant 0	84.50	1.18	22.0	21.65	1.08	0.00	<0.001	0.00
	WLAN5.8G	802.11a	Left Side	149	SKU 2	Ant 0	84.50	1.18	22.0	21.65	1.08	0.11	0.433	0.55
	WLAN5.8G	802.11a	Rear Face	157	SKU 2	Ant 1	84.50	1.18	22.0	21.56	1.11	0.00	<0.001	0.00
	WLAN5.8G	802.11a	Right Side	157	SKU 2	Ant 1	84.50	1.18	22.0	21.56	1.11	-0.12	0.816	1.07
	WLAN5.8G	802.11n HT20	Rear Face	157	SKU 2	Ant 0+1	84.00	1.19	25.0	24.51	1.12	0.00	<0.001	0.00
	WLAN5.8G	802.11n HT20	Left Side	157	SKU 2	Ant 0+1	84.00	1.19	25.0	24.51	1.12	0.19	0.237	0.32
	WLAN5.8G	802.11n HT20	Right Side	157	SKU 2	Ant 0+1	84.00	1.19	25.0	24.51	1.12	-0.16	0.774	1.03
	WLAN5.8G	802.11a	Right Side	149	SKU 2	Ant 1	84.50	1.18	21.5	21.44	1.01	0.03	0.703	0.84
15	WLAN5.8G	802.11n HT20	Right Side	153	SKU 2	Ant 0+1	84.00	1.19	24.5	24.29	1.05	-0.04	0.875	1.09
	WLAN5.8G	802.11n HT20	Right Side	153	SKU 1	Ant 0+1	84.00	1.19	24.5	24.29	1.05	-0.09	0.811	1.01
	WLAN5.8G	802.11n HT20	Right Side	157	SKU 1	Ant 0+1	84.00	1.19	25.0	24.51	1.12	0.03	0.788	1.05
	WLAN5.8G	802.11n HT20	Right Side	153	SKU 3	Ant 0+1	84.00	1.19	24.5	24.29	1.05	0.10	0.796	0.99
	WLAN5.8G	802.11n HT20	Right Side	157	SKU 3	Ant 0+1	84.00	1.19	25.0	24.51	1.12	0.12	0.764	1.02
	WLAN5.8G	802.11n HT20	Right Side	153	SKU 2	Ant 0+1	84.00	1.19	24.5	24.29	1.05	0.01	0.832	1.04
	BT	BDR	Rear Face	78	SKU 2	Ant 1	76.90	1.30	10.5	10.35	1.04	0.00	<0.001	0.00
16	BT	BDR	Right Side	78	SKU 2	Ant 1	76.90	1.30	10.5	10.35	1.04	-0.12	0.033	0.04
	BT	BDR	Right Side	78	SKU 1	Ant 1	76.90	1.30	10.5	10.35	1.04	0.12	0.031	0.04
	BT	BDR	Right Side	78	SKU 3	Ant 1	76.90	1.30	10.5	10.35	1.04	-0.08	0.028	0.04

Note: The "< 0.001" means there is no SAR value or the SAR is too low to be measured.



**4.7.3 SAR Measurement Variability**

According to KDB 865664 D01, SAR measurement variability was assessed for each frequency band, which is determined by the SAR probe calibration point and tissue-equivalent medium used for the device measurements. When both head and body tissue-equivalent media are required for SAR measurements in a frequency band, the variability measurement procedures should be applied to the tissue medium with the highest measured SAR, using the highest measured SAR configuration for that tissue-equivalent medium. Alternatively, if the highest measured SAR for both head and body tissue-equivalent media are  $\leq 1.45$  W/kg and the ratio of these highest SAR values, i.e., largest divided by smallest value, is  $\leq 1.10$ , the highest SAR configuration for either head or body tissue-equivalent medium may be used to perform the repeated measurement. These additional measurements are repeated after the completion of all measurements requiring the same head or body tissue-equivalent medium in a frequency band. The test device should be returned to ambient conditions (normal room temperature) with the battery fully charged before it is re-mounted on the device holder for the repeated measurement(s) to minimize any unexpected variations in the repeated results.

SAR repeated measurement procedure:

1. When the highest measured SAR is  $< 0.80$  W/kg, repeated measurement is not required.
2. When the highest measured SAR is  $\geq 0.80$  W/kg, repeat that measurement once.
3. If the ratio of largest to smallest SAR for the original and first repeated measurements is  $> 1.20$ , or when the original or repeated measurement is  $\geq 1.45$  W/kg, perform a second repeated measurement.
4. If the ratio of largest to smallest SAR for the original, first and second repeated measurements is  $> 1.20$ , and the original, first or second repeated measurement is  $\geq 1.5$  W/kg, perform a third repeated measurement.

Band	Mode	Test Position	Ch.	Original Measured SAR-1g (W/kg)	1st Repeated SAR-1g (W/kg)	L/S Ratio	2nd Repeated SAR-1g (W/kg)	L/S Ratio	3rd Repeated SAR-1g (W/kg)	L/S Ratio
WCDMA II	RMC12.2K	Top Side	9262	1.08	1.03	1.05	N/A	N/A	N/A	N/A
WCDMA IV	RMC12.2K	Top Side	1312	1.08	1.06	1.02	N/A	N/A	N/A	N/A
LTE2	QPSK20M	Top Side	18700	1.07	1.01	1.06	N/A	N/A	N/A	N/A
LTE13	QPSK10M	Top Side	23230	0.9	0.888	1.01	N/A	N/A	N/A	N/A
LTE14	QPSK10M	Top Side	23330	0.837	0.811	1.03	N/A	N/A	N/A	N/A
LTE66	QPSK20M	Top Side	132072	1.19	1.15	1.03	N/A	N/A	N/A	N/A
WLAN5.3G	802.11a	Right Side	60	1.03	0.995	1.04	N/A	N/A	N/A	N/A
WLAN5.6G	802.11n HT40	Right Side	110	0.917	0.911	1.01	N/A	N/A	N/A	N/A
WLAN5.8G	802.11n HT20	Right Side	153	0.875	0.832	1.05	N/A	N/A	N/A	N/A

## FCC SAR Test Report

### 4.7.4 Simultaneous Multi-band Transmission Evaluation

#### <Possibilities of Simultaneous Transmission>

The simultaneous transmission possibilities for this device are listed as below.

Simultaneous TX Combination	Capable Transmit Configurations	Body Exposure Condition
1	WCDMA + WLAN 2.4G	Yes
2	WCDMA + WLAN 5G	Yes
3	WCDMA + BT	Yes
4	LTE + WLAN 2.4G	Yes
5	LTE + WLAN 5G	Yes
6	LTE + BT	Yes

#### Note :

1. The WLAN 2.4G and WLAN 5G cannot transmit simultaneously.

# FCC SAR Test Report

## <Estimated SAR Calculation>

According to KDB 447498 D01, when standalone SAR test exclusion applies to an antenna that transmits simultaneously with other antennas, the standalone SAR was estimated according to following formula to result in substantially conservative SAR values of  $\leq 0.4$  W/kg to determine simultaneous transmission SAR test exclusion.

$$\text{Estimated SAR} = \frac{\text{Max. Tune up Power}_{(mW)}}{\text{Min. Test Separation Distance}_{(mm)}} \times \frac{\sqrt{f_{(GHz)}}}{7.5}$$

If the minimum test separation distance is  $< 5$  mm, a distance of 5 mm is used for estimated SAR calculation. When the test separation distance is  $> 50$  mm, the 0.4 W/kg is used for SAR-1g.

Mode / Band	Frequency (GHz)	Max. Tune-up Power (dBm)	Test Position	Separation Distance (mm)	Estimated SAR (W/kg)
WCDMA II	1.9076	19.5	Body	5	0.40
WCDMA IV	1.7526	20.5	Body	5	0.40
WCDMA V	0.8466	20.0	Body	5	0.40
LTE 2	1.91	19.5	Body	5	0.40
LTE 4	1.754	21.5	Body	5	0.40
LTE 5	0.848	21.0	Body	5	0.40
LTE 7	2.57	17.0	Body	5	0.40
LTE 12	0.716	24.0	Body	5	0.40
LTE 13	0.787	22.5	Body	5	0.40
LTE 14	0.798	22.5	Body	5	0.40
LTE 26	0.849	21.0	Body	5	0.40
LTE 41	2.69	19.0	Body	5	0.40
LTE 66	1.78	21.5	Body	5	0.40
WLAN (DTS)	2.462	23.5	Body	5	0.40
WLAN (NII)	5.24	23.0	Body	5	0.40
WLAN (NII)	5.32	23.5	Body	5	0.40
WLAN (NII)	5.7	23.5	Body	5	0.40
WLAN (NII)	5.825	25.0	Body	5	0.40
BT (DSS)	2.48	10.5	Body	5	0.40

### Note:

1. The separation distance is determined from the outer housing of the EUT to the user.
2. When standalone SAR testing is not required, an estimated SAR can be applied to determine simultaneous transmission SAR test exclusion.

# FCC SAR Test Report

## <SAR Summation Analysis>

Since all the verified WWAN SAR values are less than the values in original report, the simultaneous transmission evaluation is combined Max. WWAN SAR data of this model from BV CPS report (Report No.: SA180907C14A).

Simultaneous transmission SAR test exclusion is determined for each operating configuration and exposure condition according to the reported standalone SAR of each applicable simultaneous transmitting antenna. When the sum of SAR<sub>1g</sub> of all simultaneously transmitting antennas in an operating mode and exposure condition combination is within the SAR limit (SAR<sub>1g</sub> 1.6 W/kg), the simultaneous transmission SAR is not required. When the sum of SAR<sub>1g</sub> is greater than the SAR limit (SAR<sub>1g</sub> 1.6 W/kg), SAR test exclusion is determined by the SPLSR.

### Tablet PC Mode

No.	Conditions (SAR1+SAR2)	Exposure Condition	Test Position	Max. SAR1	Max. SAR2	SAR Summation	SPLSR Analysis
01	WCDMA II + WLAN (DTS)	Body	Rear Face	0.01	0.00	0.01	∑ SAR < 1.6, Not required
			Left Side	0.05	0.50	0.55	∑ SAR < 1.6, Not required
			Right Side	0.00	0.60	0.60	∑ SAR < 1.6, Not required
			Top Side	1.17	0.40	1.57	∑ SAR < 1.6, Not required
			Bottom Side	0.40	0.40	0.80	∑ SAR < 1.6, Not required
02	WCDMA II + WLAN (NII)	Body	Rear Face	0.01	0.00	0.01	∑ SAR < 1.6, Not required
			Left Side	0.05	0.98	1.03	∑ SAR < 1.6, Not required
			Right Side	0.00	1.36	1.36	∑ SAR < 1.6, Not required
			Top Side	1.17	0.40	1.57	∑ SAR < 1.6, Not required
			Bottom Side	0.40	0.40	0.80	∑ SAR < 1.6, Not required
03	WCDMA II + BT (DSS)	Body	Rear Face	0.01	0.00	0.01	∑ SAR < 1.6, Not required
			Left Side	0.05	0.40	0.45	∑ SAR < 1.6, Not required
			Right Side	0.00	0.04	0.04	∑ SAR < 1.6, Not required
			Top Side	1.17	0.40	1.57	∑ SAR < 1.6, Not required
			Bottom Side	0.40	0.40	0.80	∑ SAR < 1.6, Not required

# FCC SAR Test Report

No.	Conditions (SAR1+SAR2)	Exposure Condition	Test Position	Max. SAR1	Max. SAR2	SAR Summation	SPLSR Analysis
04	WCDMA IV + WLAN (DTS)	Body	Rear Face	0.00	0.00	0.00	$\Sigma$ SAR < 1.6, Not required
			Left Side	0.11	0.50	0.61	$\Sigma$ SAR < 1.6, Not required
			Right Side	0.00	0.60	0.60	$\Sigma$ SAR < 1.6, Not required
			Top Side	1.08	0.40	1.48	$\Sigma$ SAR < 1.6, Not required
			Bottom Side	0.40	0.40	0.80	$\Sigma$ SAR < 1.6, Not required
05	WCDMA IV + WLAN (NII)	Body	Rear Face	0.00	0.00	0.00	$\Sigma$ SAR < 1.6, Not required
			Left Side	0.11	0.98	1.09	$\Sigma$ SAR < 1.6, Not required
			Right Side	0.00	1.36	1.36	$\Sigma$ SAR < 1.6, Not required
			Top Side	1.08	0.40	1.48	$\Sigma$ SAR < 1.6, Not required
			Bottom Side	0.40	0.40	0.80	$\Sigma$ SAR < 1.6, Not required
06	WCDMA IV + BT (DSS)	Body	Rear Face	0.00	0.00	0.00	$\Sigma$ SAR < 1.6, Not required
			Left Side	0.11	0.40	0.51	$\Sigma$ SAR < 1.6, Not required
			Right Side	0.00	0.04	0.04	$\Sigma$ SAR < 1.6, Not required
			Top Side	1.08	0.40	1.48	$\Sigma$ SAR < 1.6, Not required
			Bottom Side	0.40	0.40	0.80	$\Sigma$ SAR < 1.6, Not required

No.	Conditions (SAR1+SAR2)	Exposure Condition	Test Position	Max. SAR1	Max. SAR2	SAR Summation	SPLSR Analysis
07	WCDMA V + WLAN (DTS)	Body	Rear Face	0.00	0.00	0.00	$\Sigma$ SAR < 1.6, Not required
			Left Side	0.00	0.50	0.50	$\Sigma$ SAR < 1.6, Not required
			Right Side	0.00	0.60	0.60	$\Sigma$ SAR < 1.6, Not required
			Top Side	0.72	0.40	1.12	$\Sigma$ SAR < 1.6, Not required
			Bottom Side	0.40	0.40	0.80	$\Sigma$ SAR < 1.6, Not required
08	WCDMA V + WLAN (NII)	Body	Rear Face	0.00	0.00	0.00	$\Sigma$ SAR < 1.6, Not required
			Left Side	0.00	0.98	0.98	$\Sigma$ SAR < 1.6, Not required
			Right Side	0.00	1.36	1.36	$\Sigma$ SAR < 1.6, Not required
			Top Side	0.72	0.40	1.12	$\Sigma$ SAR < 1.6, Not required
			Bottom Side	0.40	0.40	0.80	$\Sigma$ SAR < 1.6, Not required
09	WCDMA V + BT (DSS)	Body	Rear Face	0.00	0.00	0.00	$\Sigma$ SAR < 1.6, Not required
			Left Side	0.00	0.40	0.40	$\Sigma$ SAR < 1.6, Not required
			Right Side	0.00	0.04	0.04	$\Sigma$ SAR < 1.6, Not required
			Top Side	0.72	0.40	1.12	$\Sigma$ SAR < 1.6, Not required
			Bottom Side	0.40	0.40	0.80	$\Sigma$ SAR < 1.6, Not required

# FCC SAR Test Report

No.	Conditions (SAR1+SAR2)	Exposure Condition	Test Position	Max. SAR1	Max. SAR2	SAR Summation	SPLSR Analysis
10	LTE 2 + WLAN (DTS)	Body	Rear Face	0.01	0.00	0.01	$\Sigma$ SAR < 1.6, Not required
			Left Side	0.06	0.50	0.56	$\Sigma$ SAR < 1.6, Not required
			Right Side	0.00	0.60	0.60	$\Sigma$ SAR < 1.6, Not required
			Top Side	1.10	0.40	1.50	$\Sigma$ SAR < 1.6, Not required
			Bottom Side	0.40	0.40	0.80	$\Sigma$ SAR < 1.6, Not required
11	LTE 2 + WLAN (NII)	Body	Rear Face	0.01	0.00	0.01	$\Sigma$ SAR < 1.6, Not required
			Left Side	0.06	0.98	1.04	$\Sigma$ SAR < 1.6, Not required
			Right Side	0.00	1.36	1.36	$\Sigma$ SAR < 1.6, Not required
			Top Side	1.10	0.40	1.50	$\Sigma$ SAR < 1.6, Not required
			Bottom Side	0.40	0.40	0.80	$\Sigma$ SAR < 1.6, Not required
12	LTE 2 + BT (DSS)	Body	Rear Face	0.01	0.00	0.01	$\Sigma$ SAR < 1.6, Not required
			Left Side	0.06	0.40	0.46	$\Sigma$ SAR < 1.6, Not required
			Right Side	0.00	0.04	0.04	$\Sigma$ SAR < 1.6, Not required
			Top Side	1.10	0.40	1.50	$\Sigma$ SAR < 1.6, Not required
			Bottom Side	0.40	0.40	0.80	$\Sigma$ SAR < 1.6, Not required

No.	Conditions (SAR1+SAR2)	Exposure Condition	Test Position	Max. SAR1	Max. SAR2	SAR Summation	SPLSR Analysis
13	LTE 7 + WLAN (DTS)	Body	Rear Face	0.00	0.00	0.00	$\Sigma$ SAR < 1.6, Not required
			Left Side	0.00	0.50	0.50	$\Sigma$ SAR < 1.6, Not required
			Right Side	0.00	0.60	0.60	$\Sigma$ SAR < 1.6, Not required
			Top Side	0.78	0.40	1.18	$\Sigma$ SAR < 1.6, Not required
			Bottom Side	0.40	0.40	0.80	$\Sigma$ SAR < 1.6, Not required
14	LTE 7 + WLAN (NII)	Body	Rear Face	0.00	0.00	0.00	$\Sigma$ SAR < 1.6, Not required
			Left Side	0.00	0.98	0.98	$\Sigma$ SAR < 1.6, Not required
			Right Side	0.00	1.36	1.36	$\Sigma$ SAR < 1.6, Not required
			Top Side	0.78	0.40	1.18	$\Sigma$ SAR < 1.6, Not required
			Bottom Side	0.40	0.40	0.80	$\Sigma$ SAR < 1.6, Not required
15	LTE 7 + BT (DSS)	Body	Rear Face	0.00	0.00	0.00	$\Sigma$ SAR < 1.6, Not required
			Left Side	0.00	0.40	0.40	$\Sigma$ SAR < 1.6, Not required
			Right Side	0.00	0.04	0.04	$\Sigma$ SAR < 1.6, Not required
			Top Side	0.78	0.40	1.18	$\Sigma$ SAR < 1.6, Not required
			Bottom Side	0.40	0.40	0.80	$\Sigma$ SAR < 1.6, Not required

# FCC SAR Test Report

No.	Conditions (SAR1+SAR2)	Exposure Condition	Test Position	Max. SAR1	Max. SAR2	SAR Summation	SPLSR Analysis
16	LTE 12 + WLAN (DTS)	Body	Rear Face	0.00	0.00	0.00	$\Sigma$ SAR < 1.6, Not required
			Left Side	0.00	0.50	0.50	$\Sigma$ SAR < 1.6, Not required
			Right Side	0.00	0.60	0.60	$\Sigma$ SAR < 1.6, Not required
			Top Side	0.84	0.40	1.24	$\Sigma$ SAR < 1.6, Not required
			Bottom Side	0.40	0.40	0.80	$\Sigma$ SAR < 1.6, Not required
17	LTE 12 + WLAN (NII)	Body	Rear Face	0.00	0.00	0.00	$\Sigma$ SAR < 1.6, Not required
			Left Side	0.00	0.98	0.98	$\Sigma$ SAR < 1.6, Not required
			Right Side	0.00	1.36	1.36	$\Sigma$ SAR < 1.6, Not required
			Top Side	0.84	0.40	1.24	$\Sigma$ SAR < 1.6, Not required
			Bottom Side	0.40	0.40	0.80	$\Sigma$ SAR < 1.6, Not required
18	LTE 12 + BT (DSS)	Body	Rear Face	0.00	0.00	0.00	$\Sigma$ SAR < 1.6, Not required
			Left Side	0.00	0.40	0.40	$\Sigma$ SAR < 1.6, Not required
			Right Side	0.00	0.04	0.04	$\Sigma$ SAR < 1.6, Not required
			Top Side	0.84	0.40	1.24	$\Sigma$ SAR < 1.6, Not required
			Bottom Side	0.40	0.40	0.80	$\Sigma$ SAR < 1.6, Not required

No.	Conditions (SAR1+SAR2)	Exposure Condition	Test Position	Max. SAR1	Max. SAR2	SAR Summation	SPLSR Analysis
19	LTE 13 + WLAN (DTS)	Body	Rear Face	0.00	0.00	0.00	$\Sigma$ SAR < 1.6, Not required
			Left Side	0.05	0.50	0.55	$\Sigma$ SAR < 1.6, Not required
			Right Side	0.00	0.60	0.60	$\Sigma$ SAR < 1.6, Not required
			Top Side	0.98	0.40	1.38	$\Sigma$ SAR < 1.6, Not required
			Bottom Side	0.40	0.40	0.80	$\Sigma$ SAR < 1.6, Not required
20	LTE 13 + WLAN (NII)	Body	Rear Face	0.00	0.00	0.00	$\Sigma$ SAR < 1.6, Not required
			Left Side	0.05	0.98	1.03	$\Sigma$ SAR < 1.6, Not required
			Right Side	0.00	1.36	1.36	$\Sigma$ SAR < 1.6, Not required
			Top Side	0.98	0.40	1.38	$\Sigma$ SAR < 1.6, Not required
			Bottom Side	0.40	0.40	0.80	$\Sigma$ SAR < 1.6, Not required
21	LTE 13 + BT (DSS)	Body	Rear Face	0.00	0.00	0.00	$\Sigma$ SAR < 1.6, Not required
			Left Side	0.05	0.40	0.45	$\Sigma$ SAR < 1.6, Not required
			Right Side	0.00	0.04	0.04	$\Sigma$ SAR < 1.6, Not required
			Top Side	0.98	0.40	1.38	$\Sigma$ SAR < 1.6, Not required
			Bottom Side	0.40	0.40	0.80	$\Sigma$ SAR < 1.6, Not required

# FCC SAR Test Report

No.	Conditions (SAR1+SAR2)	Exposure Condition	Test Position	Max. SAR1	Max. SAR2	SAR Summation	SPLSR Analysis
22	LTE 14 + WLAN (DTS)	Body	Rear Face	0.00	0.00	0.00	$\Sigma$ SAR < 1.6, Not required
			Left Side	0.00	0.50	0.50	$\Sigma$ SAR < 1.6, Not required
			Right Side	0.00	0.60	0.60	$\Sigma$ SAR < 1.6, Not required
			Top Side	0.89	0.40	1.29	$\Sigma$ SAR < 1.6, Not required
			Bottom Side	0.40	0.40	0.80	$\Sigma$ SAR < 1.6, Not required
23	LTE 14 + WLAN (NII)	Body	Rear Face	0.00	0.00	0.00	$\Sigma$ SAR < 1.6, Not required
			Left Side	0.00	0.98	0.98	$\Sigma$ SAR < 1.6, Not required
			Right Side	0.00	1.36	1.36	$\Sigma$ SAR < 1.6, Not required
			Top Side	0.89	0.40	1.29	$\Sigma$ SAR < 1.6, Not required
			Bottom Side	0.40	0.40	0.80	$\Sigma$ SAR < 1.6, Not required
24	LTE 14 + BT (DSS)	Body	Rear Face	0.00	0.00	0.00	$\Sigma$ SAR < 1.6, Not required
			Left Side	0.00	0.40	0.40	$\Sigma$ SAR < 1.6, Not required
			Right Side	0.00	0.04	0.04	$\Sigma$ SAR < 1.6, Not required
			Top Side	0.89	0.40	1.29	$\Sigma$ SAR < 1.6, Not required
			Bottom Side	0.40	0.40	0.80	$\Sigma$ SAR < 1.6, Not required

No.	Conditions (SAR1+SAR2)	Exposure Condition	Test Position	Max. SAR1	Max. SAR2	SAR Summation	SPLSR Analysis
25	LTE 26 + WLAN (DTS)	Body	Rear Face	0.00	0.00	0.00	$\Sigma$ SAR < 1.6, Not required
			Left Side	0.00	0.50	0.50	$\Sigma$ SAR < 1.6, Not required
			Right Side	0.00	0.60	0.60	$\Sigma$ SAR < 1.6, Not required
			Top Side	0.80	0.40	1.20	$\Sigma$ SAR < 1.6, Not required
			Bottom Side	0.40	0.40	0.80	$\Sigma$ SAR < 1.6, Not required
26	LTE 26 + WLAN (NII)	Body	Rear Face	0.00	0.00	0.00	$\Sigma$ SAR < 1.6, Not required
			Left Side	0.00	0.98	0.98	$\Sigma$ SAR < 1.6, Not required
			Right Side	0.00	1.36	1.36	$\Sigma$ SAR < 1.6, Not required
			Top Side	0.80	0.40	1.20	$\Sigma$ SAR < 1.6, Not required
			Bottom Side	0.40	0.40	0.80	$\Sigma$ SAR < 1.6, Not required
27	LTE 26 + BT (DSS)	Body	Rear Face	0.00	0.00	0.00	$\Sigma$ SAR < 1.6, Not required
			Left Side	0.00	0.40	0.40	$\Sigma$ SAR < 1.6, Not required
			Right Side	0.00	0.04	0.04	$\Sigma$ SAR < 1.6, Not required
			Top Side	0.80	0.40	1.20	$\Sigma$ SAR < 1.6, Not required
			Bottom Side	0.40	0.40	0.80	$\Sigma$ SAR < 1.6, Not required



# FCC SAR Test Report

No.	Conditions (SAR1+SAR2)	Exposure Condition	Test Position	Max. SAR1	Max. SAR2	SAR Summation	SPLSR Analysis
28	LTE 41 + WLAN (DTS)	Body	Rear Face	0.00	0.00	0.00	$\Sigma$ SAR < 1.6, Not required
			Left Side	0.03	0.50	0.53	$\Sigma$ SAR < 1.6, Not required
			Right Side	0.00	0.60	0.60	$\Sigma$ SAR < 1.6, Not required
			Top Side	0.33	0.40	0.73	$\Sigma$ SAR < 1.6, Not required
			Bottom Side	0.40	0.40	0.80	$\Sigma$ SAR < 1.6, Not required
29	LTE 41 + WLAN (NII)	Body	Rear Face	0.00	0.00	0.00	$\Sigma$ SAR < 1.6, Not required
			Left Side	0.03	0.98	1.01	$\Sigma$ SAR < 1.6, Not required
			Right Side	0.00	1.36	1.36	$\Sigma$ SAR < 1.6, Not required
			Top Side	0.33	0.40	0.73	$\Sigma$ SAR < 1.6, Not required
			Bottom Side	0.40	0.40	0.80	$\Sigma$ SAR < 1.6, Not required
30	LTE 41 + BT (DSS)	Body	Rear Face	0.00	0.00	0.00	$\Sigma$ SAR < 1.6, Not required
			Left Side	0.03	0.40	0.43	$\Sigma$ SAR < 1.6, Not required
			Right Side	0.00	0.04	0.04	$\Sigma$ SAR < 1.6, Not required
			Top Side	0.33	0.40	0.73	$\Sigma$ SAR < 1.6, Not required
			Bottom Side	0.40	0.40	0.80	$\Sigma$ SAR < 1.6, Not required

No.	Conditions (SAR1+SAR2)	Exposure Condition	Test Position	Max. SAR1	Max. SAR2	SAR Summation	SPLSR Analysis
31	LTE 66 + WLAN (DTS)	Body	Rear Face	0.06	0.00	0.06	$\Sigma$ SAR < 1.6, Not required
			Left Side	0.14	0.50	0.64	$\Sigma$ SAR < 1.6, Not required
			Right Side	0.00	0.60	0.60	$\Sigma$ SAR < 1.6, Not required
			Top Side	1.19	0.40	1.59	$\Sigma$ SAR < 1.6, Not required
			Bottom Side	0.40	0.40	0.80	$\Sigma$ SAR < 1.6, Not required
32	LTE 66 + WLAN (NII)	Body	Rear Face	0.06	0.00	0.06	$\Sigma$ SAR < 1.6, Not required
			Left Side	0.14	0.98	1.12	$\Sigma$ SAR < 1.6, Not required
			Right Side	0.00	1.36	1.36	$\Sigma$ SAR < 1.6, Not required
			Top Side	1.19	0.40	1.59	$\Sigma$ SAR < 1.6, Not required
			Bottom Side	0.40	0.40	0.80	$\Sigma$ SAR < 1.6, Not required
33	LTE 66 + BT (DSS)	Body	Rear Face	0.06	0.00	0.06	$\Sigma$ SAR < 1.6, Not required
			Left Side	0.14	0.40	0.54	$\Sigma$ SAR < 1.6, Not required
			Right Side	0.00	0.04	0.04	$\Sigma$ SAR < 1.6, Not required
			Top Side	1.19	0.40	1.59	$\Sigma$ SAR < 1.6, Not required
			Bottom Side	0.40	0.40	0.80	$\Sigma$ SAR < 1.6, Not required

Test Engineer : Willy Chang, and Isaac Liao

## 5. Calibration of Test Equipment

Equipment	Manufacturer	Model	SN	Cal. Date	Cal. Interval
System Validation Dipole	SPEAG	D750V3	1013	Aug. 23, 2018	1 Year
System Validation Dipole	SPEAG	D835V2	4d121	Aug. 23, 2018	1 Year
System Validation Dipole	SPEAG	D1750V2	1055	Aug. 27, 2018	1 Year
System Validation Dipole	SPEAG	D1900V2	5d036	Jan. 25, 2019	1 Year
System Validation Dipole	SPEAG	D2450V2	737	Aug. 24, 2018	1 Year
System Validation Dipole	SPEAG	D2600V2	1020	Aug. 24, 2018	1 Year
System Validation Dipole	SPEAG	D5GHzV2	1019	Mar. 21, 2019	1 Year
Dosimetric E-Field Probe	SPEAG	EX3DV4	3971	Mar. 29, 2019	1 Year
Dosimetric E-Field Probe	SPEAG	EX3DV4	7375	Dec. 13, 2018	1 Year
Dosimetric E-Field Probe	SPEAG	EX3DV4	7472	Aug. 29, 2018	1 Year
Data Acquisition Electronics	SPEAG	DAE3	579	Aug. 27, 2018	1 Year
Data Acquisition Electronics	SPEAG	DAE4	1431	Mar. 25, 2019	1 Year
Data Acquisition Electronics	SPEAG	DAE4	1277	Jan. 24, 2019	1 Year
Data Acquisition Electronics	SPEAG	DAE4	916	Dec. 12, 2018	1 Year
Radio Communication Analyzer	Anritsu	MT8820C	6201381727	May. 06, 2019	1 Year
Universal Radio Communication Tester	Anritsu	MT8821C	6201502978	Jul. 20, 2018	1 Year
Spectrum Analyzer	R&S	FSL6	102006	Mar. 26, 2019	1 Year
ENA Series Network Analyzer	Agilent	E5071C	MY46214281	Jun. 08, 2018	1 Year
ENA Series Network Analyzer	Agilent	E5071C	MY46104190	Apr. 16, 2019	1 Year
Vector Signal Generator	Anritsu	MG3710A	6201599977	Mar. 21, 2019	1 Year
Power Meter	Anritsu	ML2495A	1232003	Dec. 25, 2018	1 Year
Power Sensor	Anritsu	MA2411B	1207334	Dec. 25, 2018	1 Year
Thermometer	YFE	YF-160A	130504591	Mar. 22, 2019	1 Year

## 6. Measurement Uncertainty

Source of Uncertainty	Uncertainty (± %)	Probability Distribution	Divisor	Ci (1g)	Ci (10g)	Standard Uncertainty (± %, 1g)	Standard Uncertainty (± %, 10g)	Vi
<b>Measurement System</b>								
Probe Calibration	6.0	Normal	1	1	1	6.0	6.0	∞
Axial Isotropy	4.7	Rectangular	√3	√0.5	√0.5	1.9	1.9	∞
Hemispherical Isotropy	9.6	Rectangular	√3	√0.5	√0.5	3.9	3.9	∞
Boundary Effect	1.0	Rectangular	√3	1	1	0.6	0.6	∞
Linearity	4.7	Rectangular	√3	1	1	2.7	2.7	∞
Detection Limits	0.25	Rectangular	√3	1	1	0.14	0.14	∞
Probe Modulation Response	3.5	Rectangular	√3	1	1	2.0	2.0	∞
Readout Electronics	0.3	Normal	1	1	1	0.3	0.3	∞
Response Time	0.0	Rectangular	√3	1	1	0.0	0.0	∞
Integration Time	1.7	Rectangular	√3	1	1	1.0	1.0	∞
RF Ambient Conditions – Noise	3.0	Rectangular	√3	1	1	1.7	1.7	∞
RF Ambient Conditions – Reflections	3.0	Rectangular	√3	1	1	1.7	1.7	∞
Probe Positioner Mechanical Tolerance	0.4	Rectangular	√3	1	1	0.2	0.2	∞
Probe Positioning with Respect to Phantom	2.9	Rectangular	√3	1	1	1.7	1.7	∞
Post-processing	2.0	Rectangular	√3	1	1	1.2	1.2	∞
<b>Test Sample Related</b>								
Test Sample Positioning	4.38 / 1.35	Normal	1	1	1	4.4	1.4	29
Device Holder Uncertainty	2.9 / 4.1	Normal	1	1	1	2.9	4.1	11
Power Drift of Measurement	5.0	Rectangular	√3	1	1	2.9	2.9	∞
Power Scaling	0.0	Rectangular	√3	1	1	0.0	0.0	∞
<b>Phantom and Setup</b>								
Phantom Uncertainty (Shape and Thickness Tolerances)	7.2	Rectangular	√3	1	1	4.2	4.2	∞
Liquid Conductivity ( Temperature Uncertainty)	3.24	Rectangular	√3	0.78	0.71	1.5	1.3	∞
Liquid Conductivity (Measured)	2.88	Normal	1	0.78	0.71	2.2	2.0	43
Liquid Permittivity (Temperature Uncertainty)	1.13	Rectangular	√3	0.23	0.26	0.2	0.2	∞
Liquid Permittivity (Measured)	2.50	Normal	1	0.23	0.26	0.6	0.7	54
<b>Combined Standard Uncertainty</b>						± 11.8 %	± 11.3 %	
<b>Expanded Uncertainty (K=2)</b>						± 23.6 %	± 22.6 %	

Body SAR Uncertainty Budget for Frequency Range of 300 MHz to 3 GHz

# FCC SAR Test Report

Source of Uncertainty	Uncertainty (± %)	Probability Distribution	Divisor	C <sub>i</sub> (1g)	C <sub>i</sub> (10g)	Standard Uncertainty (± %, 1g)	Standard Uncertainty (± %, 10g)	V <sub>i</sub>
<b>Measurement System</b>								
Probe Calibration	6.55	Normal	1	1	1	6.55	6.55	∞
Axial Isotropy	4.7	Rectangular	√3	0.7	0.7	1.9	1.9	∞
Hemispherical Isotropy	9.6	Rectangular	√3	0.7	0.7	3.9	3.9	∞
Boundary Effect	2.0	Rectangular	√3	1	1	1.2	1.2	∞
Linearity	4.7	Rectangular	√3	1	1	2.7	2.7	∞
Detection Limits	0.25	Rectangular	√3	1	1	0.14	0.14	∞
Probe Modulation Response	3.5	Rectangular	√3	1	1	2.0	2.0	∞
Readout Electronics	0.3	Normal	1	1	1	0.3	0.3	∞
Response Time	0.0	Rectangular	√3	1	1	0.0	0.0	∞
Integration Time	1.7	Rectangular	√3	1	1	1.0	1.0	∞
RF Ambient Conditions – Noise	3.0	Rectangular	√3	1	1	1.7	1.7	∞
RF Ambient Conditions – Reflections	3.0	Rectangular	√3	1	1	1.7	1.7	∞
Probe Positioner Mechanical Tolerance	0.4	Rectangular	√3	1	1	0.2	0.2	∞
Probe Positioning with Respect to Phantom	6.7	Rectangular	√3	1	1	3.9	3.9	∞
Post-processing	4.0	Rectangular	√3	1	1	2.3	2.3	∞
<b>Test Sample Related</b>								
Test Sample Positioning	4.38 / 1.35	Normal	1	1	1	4.4	1.4	29
Device Holder Uncertainty	2.9 / 4.1	Normal	1	1	1	2.9	4.1	11
Power Drift of Measurement	5.0	Rectangular	√3	1	1	2.9	2.9	∞
Power Scaling	0.0	Rectangular	√3	1	1	0.0	0.0	∞
<b>Phantom and Setup</b>								
Phantom Uncertainty (Shape and Thickness Tolerances)	7.6	Rectangular	√3	1	1	4.4	4.4	∞
Liquid Conductivity ( Temperature Uncertainty)	3.24	Rectangular	√3	0.78	0.71	1.5	1.3	∞
Liquid Conductivity (Measured)	2.88	Normal	1	0.78	0.71	2.2	2.0	43
Liquid Permittivity (Temperature Uncertainty)	1.13	Rectangular	√3	0.23	0.26	0.2	0.2	∞
Liquid Permittivity (Measured)	2.50	Normal	1	0.23	0.26	0.6	0.7	54
<b>Combined Standard Uncertainty</b>						± 12.8 %	± 12.4 %	
<b>Expanded Uncertainty (K=2)</b>						± 25.6 %	± 24.8 %	

## Body SAR Uncertainty Budget for Frequency Range of 3 GHz to 6 GHz

### 7. Information on the Testing Laboratories

We, Bureau Veritas Consumer Products Services (H.K.) Ltd., Taoyuan Branch, were founded in 1988 to provide our best service in EMC, Radio, Telecom and Safety consultation. Our laboratories are accredited and approved according to ISO/IEC 17025.

If you have any comments, please feel free to contact us at the following:

**Taiwan HwaYa EMC/RF/Safety Lab:**

Add: No. 19, Hwa Ya 2nd Rd, Wen Hwa Vil., Kwei Shan Hsiang, Taoyuan Hsien 333, Taiwan, R.O.C.

Tel: 886-3-318-3232

Fax: 886-3-327-0892

**Taiwan LinKo EMC/RF Lab:**

Add: No. 47-2, 14th Ling, Chia Pau Vil., Linkou Dist., New Taipei City 244, Taiwan, R.O.C.

Tel: 886-2-2605-2180

Fax: 886-2-2605-1924

**Taiwan HsinChu EMC/RF/Telecom Lab:**

Add: E-2, No.1, Li Hsin 1<sup>st</sup> Road, Hsinchu Science Park, Hsinchu City 30078, Taiwan, R.O.C.

Tel: 886-3-666-8565

Fax: 886-3-666-8323

**Email:** [service.adt@tw.bureauveritas.com](mailto:service.adt@tw.bureauveritas.com)

**Web Site:** [www.bureauveritas-adt.com](http://www.bureauveritas-adt.com)

The road map of all our labs can be found in our web site also.

---END---

## Appendix A. SAR Plots of System Verification

The plots for system verification with largest deviation for each SAR system combination are shown as follows.

## System Check\_H750\_190620

**DUT: Dipole 750 MHz; Type: D750V3; SN: 1013**

Communication System: CW; Frequency: 750 MHz; Duty Cycle: 1:1

Medium: H06T09N1\_0620 Medium parameters used:  $f = 750$  MHz;  $\sigma = 0.891$  S/m;  $\epsilon_r = 42.928$ ;  $\rho = 1000$  kg/m<sup>3</sup>

Ambient Temperature : 23.8 °C ; Liquid Temperature : 23.5 °C

DASY5 Configuration:

- Probe: EX3DV4 - SN7375; ConvF(10.35, 10.35, 10.35); Calibrated: 2018/12/13
- Sensor-Surface: 1.4mm (Mechanical Surface Detection)
- Electronics: DAE4 Sn916; Calibrated: 2018/12/12
- Phantom: ELI Phantom\_1245; Type: QDOVA002AA;
- Measurement SW: DASY52, Version 52.10 (2); SEMCAD X Version 14.6.12 (7470)

**Pin=250mW/Area Scan (61x81x1):** Interpolated grid: dx=1.500 mm, dy=1.500 mm  
Maximum value of SAR (interpolated) = 2.65 W/kg

**Pin=250mW/Zoom Scan (5x5x7)/Cube 0:** Measurement grid: dx=8mm, dy=8mm, dz=5mm  
Reference Value = 57.07 V/m; Power Drift = -0.02 dB  
Peak SAR (extrapolated) = 3.05 W/kg  
**SAR(1 g) = 1.97 W/kg; SAR(10 g) = 1.28 W/kg**  
Maximum value of SAR (measured) = 2.67 W/kg

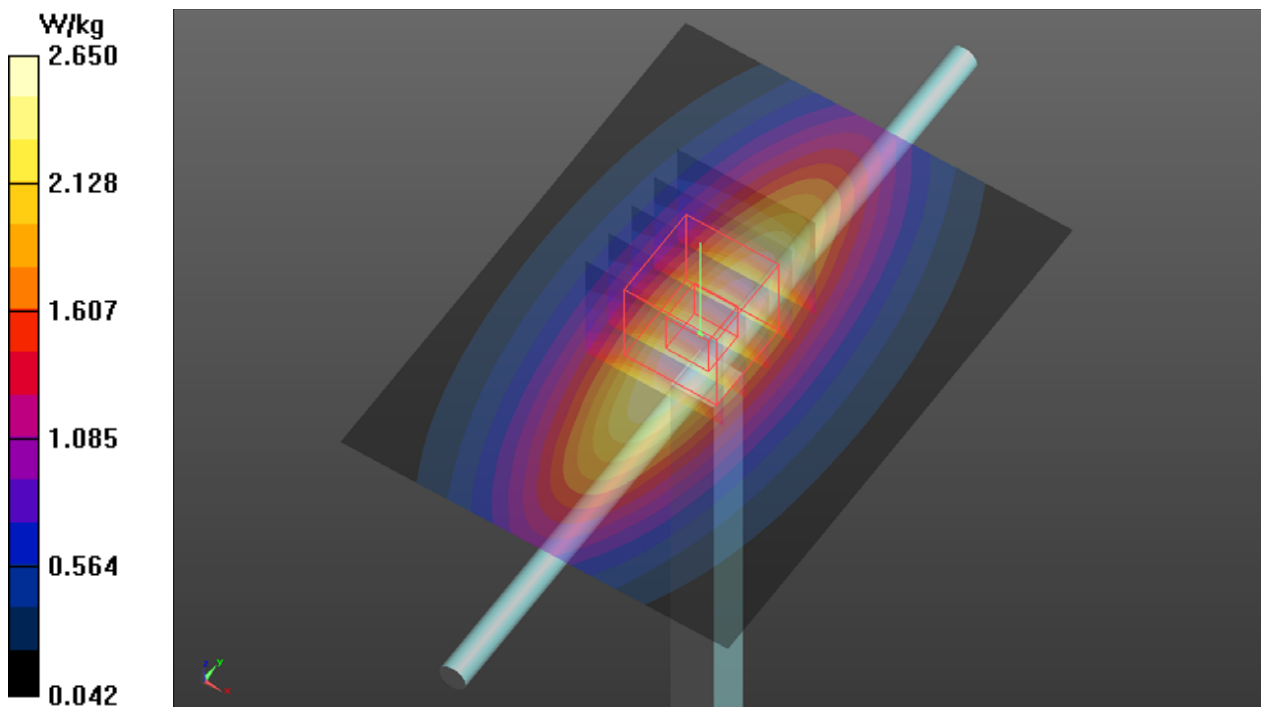

## System Check\_H835\_190619

**DUT: Dipole 835 MHz; Type: D835V2; SN: 4d121**

Communication System: CW; Frequency: 835 MHz; Duty Cycle: 1:1

Medium: H07T10N1\_0619 Medium parameters used:  $f = 835 \text{ MHz}$ ;  $\sigma = 0.901 \text{ S/m}$ ;  $\epsilon_r = 42.636$ ;  $\rho = 1000 \text{ kg/m}^3$

Ambient Temperature :  $23.8 \text{ }^\circ\text{C}$  ; Liquid Temperature :  $23.1 \text{ }^\circ\text{C}$

DASY5 Configuration:

- Probe: EX3DV4 - SN7375; ConvF(10.13, 10.13, 10.13); Calibrated: 2018/12/13
- Sensor-Surface: 1.4mm (Mechanical Surface Detection)
- Electronics: DAE4 Sn916; Calibrated: 2018/12/12
- Phantom: ELI Phantom\_1245; Type: QDOVA002AA;
- Measurement SW: DASY52, Version 52.10 (2); SEMCAD X Version 14.6.12 (7470)

**Pin=250mW/Area Scan (61x61x1):** Interpolated grid:  $dx=1.500 \text{ mm}$ ,  $dy=1.500 \text{ mm}$

Maximum value of SAR (interpolated) =  $3.17 \text{ W/kg}$

**Pin=250mW/Zoom Scan (5x5x7)/Cube 0:** Measurement grid:  $dx=8\text{mm}$ ,  $dy=8\text{mm}$ ,  $dz=5\text{mm}$

Reference Value =  $56.73 \text{ V/m}$ ; Power Drift =  $-0.09 \text{ dB}$

Peak SAR (extrapolated) =  $3.53 \text{ W/kg}$

**SAR(1 g) =  $2.41 \text{ W/kg}$ ; SAR(10 g) =  $1.59 \text{ W/kg}$**

Maximum value of SAR (measured) =  $3.18 \text{ W/kg}$

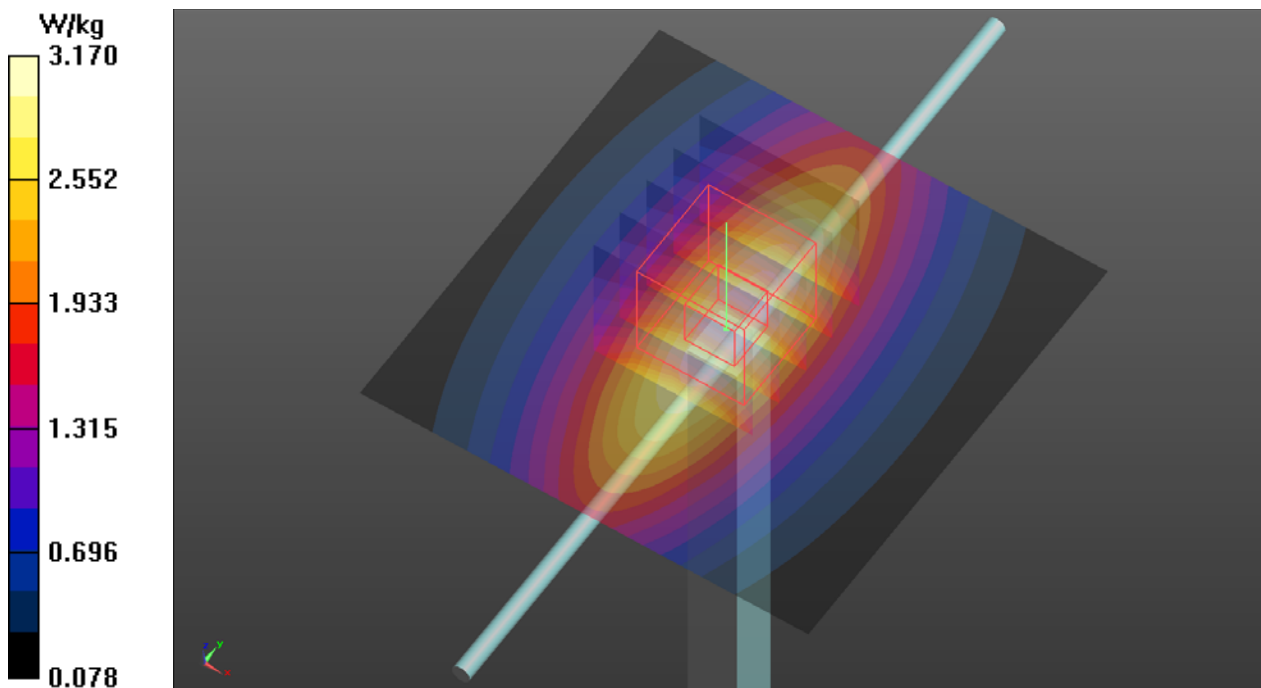



## System Check\_H1750\_190620

**DUT: Dipole 1750 MHz; Type: D1750V2; SN: 1055**

Communication System: CW; Frequency: 1750 MHz; Duty Cycle: 1:1

Medium: H16T20N1\_0620 Medium parameters used:  $f = 1750$  MHz;  $\sigma = 1.328$  S/m;  $\epsilon_r = 40.136$ ;  $\rho = 1000$  kg/m<sup>3</sup>

Ambient Temperature : 23.8 °C ; Liquid Temperature : 23.3 °C

DASY5 Configuration:

- Probe: EX3DV4 - SN3971; ConvF(8.8, 8.8, 8.8); Calibrated: 2019/03/29
- Sensor-Surface: 1.4mm (Mechanical Surface Detection)
- Electronics: DAE4 Sn1431; Calibrated: 2019/03/25
- Phantom: ELI Phantom\_1043; Type: QDOVA;
- Measurement SW: DASY52, Version 52.10 (2); SEMCAD X Version 14.6.12 (7470)

**Pin=250mW/Area Scan (61x61x1):** Interpolated grid: dx=1.500 mm, dy=1.500 mm  
Maximum value of SAR (interpolated) = 14.8 W/kg

**Pin=250mW/Zoom Scan (5x5x7)/Cube 0:** Measurement grid: dx=8mm, dy=8mm, dz=5mm  
Reference Value = 109.0 V/m; Power Drift = -0.06 dB  
Peak SAR (extrapolated) = 17.7 W/kg  
**SAR(1 g) = 9.47 W/kg; SAR(10 g) = 5.01 W/kg**  
Maximum value of SAR (measured) = 14.8 W/kg

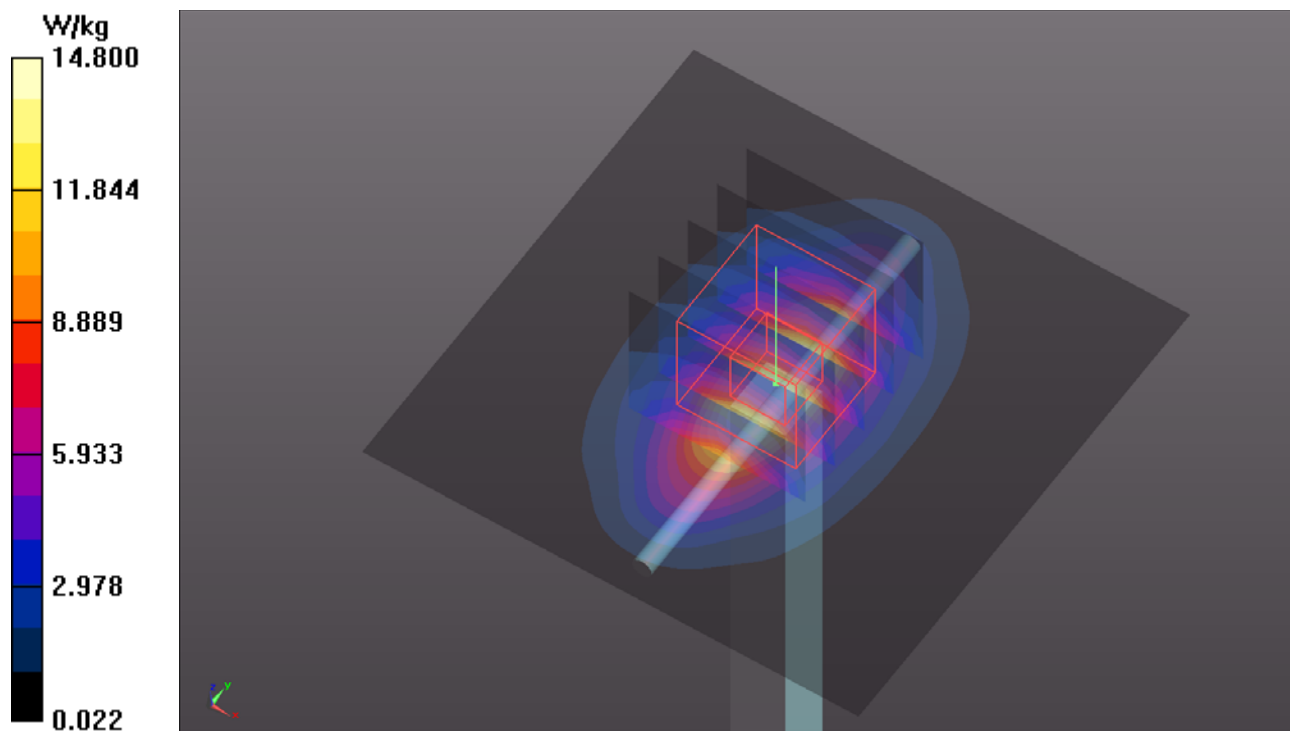

## System Check\_H1900\_190619

**DUT: Dipole 1900 MHz; Type: D1900V2; SN: 5d036**

Communication System: CW; Frequency: 1900 MHz; Duty Cycle: 1:1

Medium: H16T20N1\_0619 Medium parameters used:  $f = 1900$  MHz;  $\sigma = 1.456$  S/m;  $\epsilon_r = 38.805$ ;  $\rho = 1000$  kg/m<sup>3</sup>

Ambient Temperature : 23.7 °C ; Liquid Temperature : 23.2 °C

DASY5 Configuration:

- Probe: EX3DV4 - SN7375; ConvF(8.26, 8.26, 8.26); Calibrated: 2018/12/13
- Sensor-Surface: 1.4mm (Mechanical Surface Detection)
- Electronics: DAE4 Sn916; Calibrated: 2018/12/12
- Phantom: ELI Phantom\_1245; Type: QDOVA002AA;
- Measurement SW: DASY52, Version 52.10 (2); SEMCAD X Version 14.6.12 (7470)

**Pin=250mW/Area Scan (61x61x1):** Interpolated grid: dx=1.500 mm, dy=1.500 mm

Maximum value of SAR (interpolated) = 16.2 W/kg

**Pin=250mW/Zoom Scan (5x5x7)/Cube 0:** Measurement grid: dx=8mm, dy=8mm, dz=5mm

Reference Value = 109.5 V/m; Power Drift = -0.03 dB

Peak SAR (extrapolated) = 19.8 W/kg

**SAR(1 g) = 10.5 W/kg; SAR(10 g) = 5.46 W/kg**

Maximum value of SAR (measured) = 16.5 W/kg

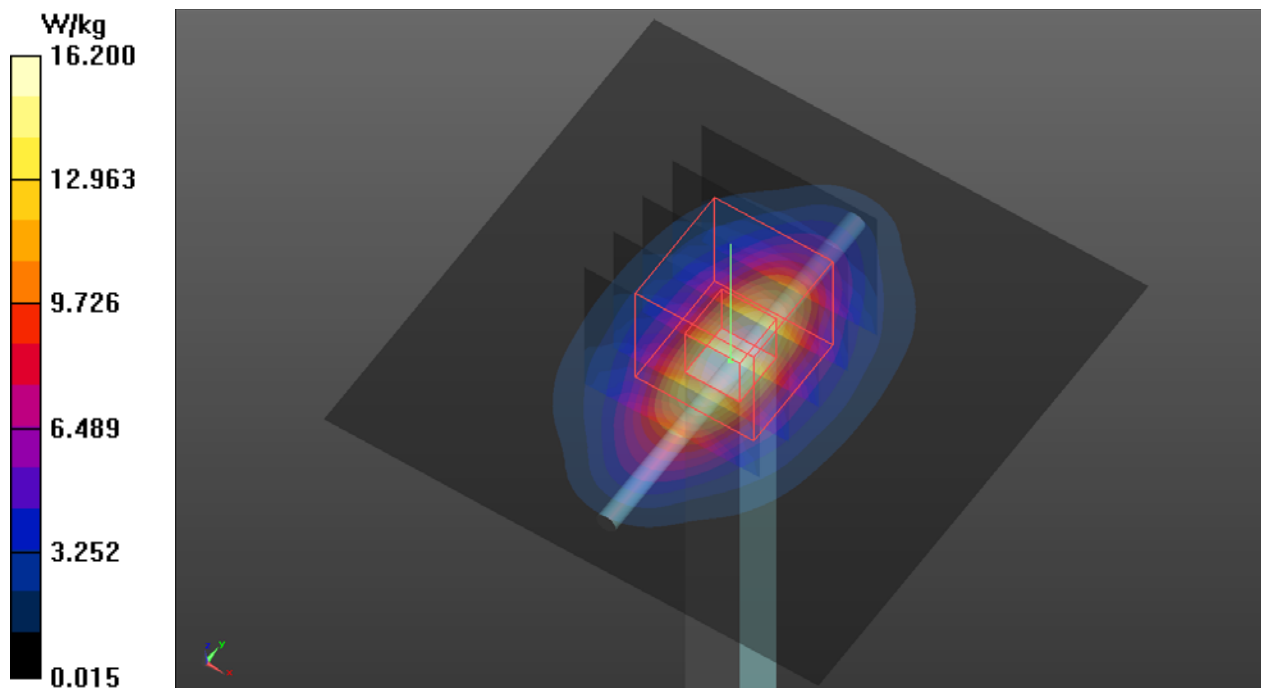

## System Check\_H2450\_190626

**DUT: Dipole 2450 MHz; Type: D2450V2; SN: 737**

Communication System: CW; Frequency: 2450 MHz; Duty Cycle: 1:1

Medium: H19T27N1\_0626 Medium parameters used:  $f = 2450$  MHz;  $\sigma = 1.885$  S/m;  $\epsilon_r = 38.248$ ;  $\rho = 1000$  kg/m<sup>3</sup>

Ambient Temperature : 23.6 °C ; Liquid Temperature : 23.2 °C

DASY5 Configuration:

- Probe: EX3DV4 - SN7375; ConvF(7.64, 7.64, 7.64); Calibrated: 2018/12/13
- Sensor-Surface: 1.4mm (Mechanical Surface Detection)
- Electronics: DAE4 Sn1277; Calibrated: 2019/01/24
- Phantom: ELI Phantom\_1204; Type: QDOVA;
- Measurement SW: DASY52, Version 52.10 (2); SEMCAD X Version 14.6.12 (7450)

**Pin=250mW/Area Scan (81x81x1):** Interpolated grid: dx=1.200 mm, dy=1.200 mm

Maximum value of SAR (interpolated) = 22.7 W/kg

**Pin=250mW/Zoom Scan (7x7x7)/Cube 0:** Measurement grid: dx=5mm, dy=5mm, dz=5mm

Reference Value = 105.6 V/m; Power Drift = -0.03 dB

Peak SAR (extrapolated) = 28.2 W/kg

**SAR(1 g) = 13.5 W/kg; SAR(10 g) = 6.25 W/kg**

Maximum value of SAR (measured) = 22.7 W/kg

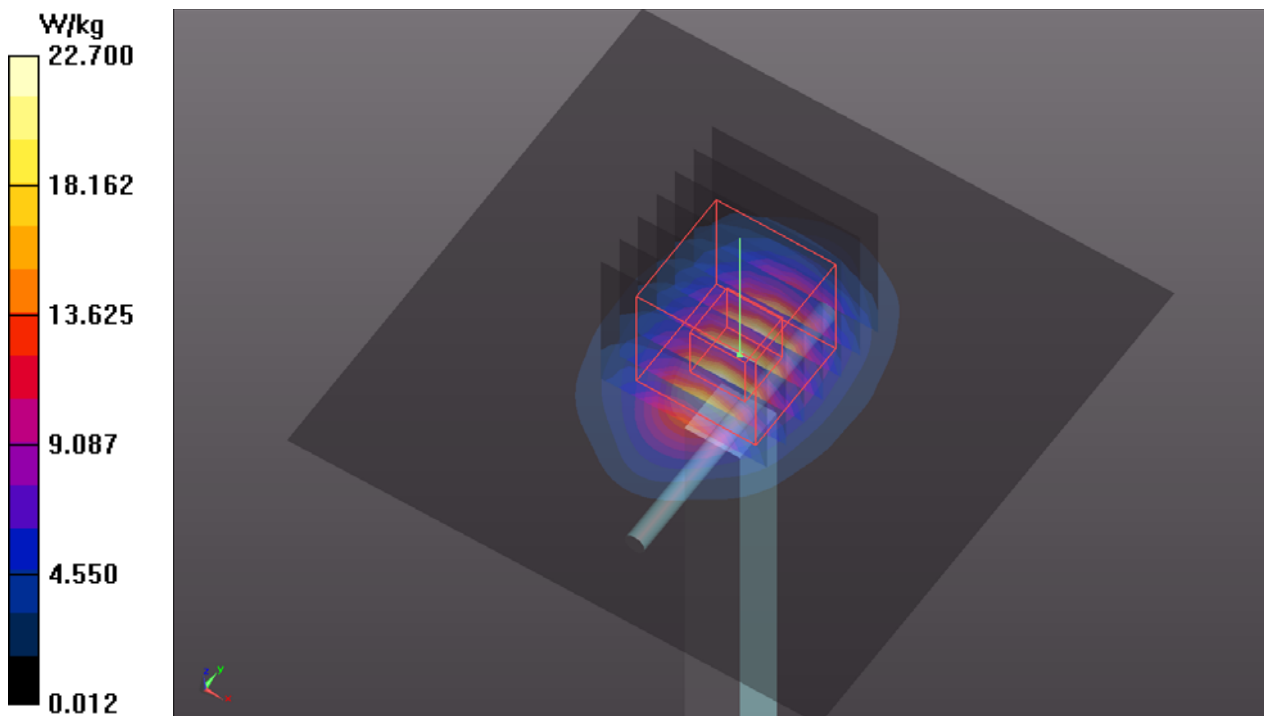

## System Check\_H2600\_190629

**DUT: Dipole 2600 MHz; Type: D2600V2; SN: 1020**

Communication System: CW; Frequency: 2600 MHz; Duty Cycle: 1:1

Medium: H19T27N1\_0629 Medium parameters used:  $f = 2600$  MHz;  $\sigma = 2.004$  S/m;  $\epsilon_r = 38.246$ ;  $\rho = 1000$  kg/m<sup>3</sup>

Ambient Temperature : 23.6 °C ; Liquid Temperature : 23.2 °C

DASY5 Configuration:

- Probe: EX3DV4 - SN7375; ConvF(7.42, 7.42, 7.42); Calibrated: 2018/12/13
- Sensor-Surface: 1.4mm (Mechanical Surface Detection)
- Electronics: DAE4 Sn1277; Calibrated: 2019/01/24
- Phantom: ELI Phantom\_1204; Type: QDOVA;
- Measurement SW: DASY52, Version 52.10 (2); SEMCAD X Version 14.6.12 (7450)

**Pin=250mW/Area Scan (81x81x1):** Interpolated grid: dx=1.200 mm, dy=1.200 mm

Maximum value of SAR (interpolated) = 25.4 W/kg

**Pin=250mW/Zoom Scan (7x7x7)/Cube 0:** Measurement grid: dx=5mm, dy=5mm, dz=5mm

Reference Value = 106.5 V/m; Power Drift = 0.04 dB

Peak SAR (extrapolated) = 32.1 W/kg

**SAR(1 g) = 14.9 W/kg; SAR(10 g) = 6.69 W/kg**

Maximum value of SAR (measured) = 25.6 W/kg

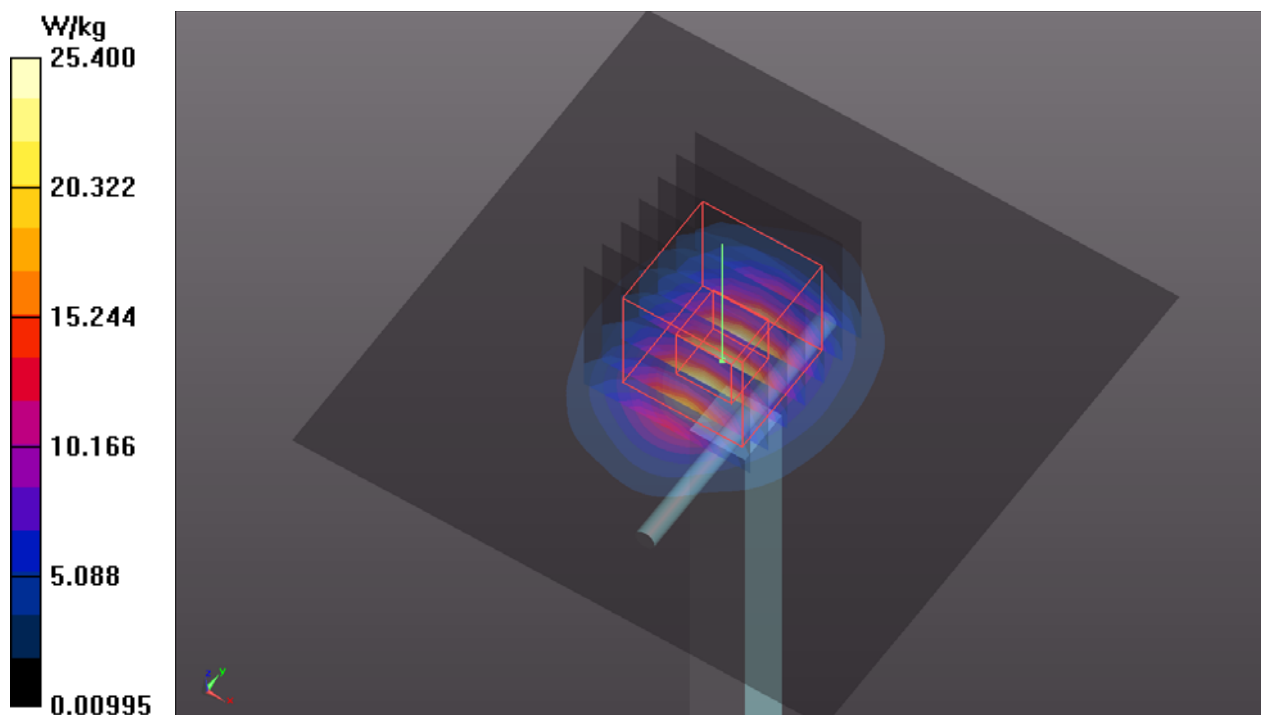

## System Check\_H5250\_190704

**DUT: Dipole 5 GHz; Type: D5GHzV2; SN: 1019**

Communication System: CW; Frequency: 5250 MHz; Duty Cycle: 1:1

Medium: H34T60N1\_0704 Medium parameters used:  $f = 5250$  MHz;  $\sigma = 4.741$  S/m;  $\epsilon_r = 36.971$ ;  $\rho = 1000$  kg/m<sup>3</sup>

Ambient Temperature : 23.7 °C ; Liquid Temperature : 23.4 °C

DASY5 Configuration:

- Probe: EX3DV4 - SN7472; ConvF(5.62, 5.62, 5.62); Calibrated: 2018/08/29
- Sensor-Surface: 1.4mm (Mechanical Surface Detection)
- Electronics: DAE3 Sn579; Calibrated: 2018/08/27
- Phantom: ELI Phantom\_1245; Type: QDOVA002AA;
- Measurement SW: DASY52, Version 52.10 (2); SEMCAD X Version 14.6.12 (7470)

**Pin=100mW/Area Scan (91x91x1):** Interpolated grid: dx=1.000 mm, dy=1.000 mm  
Maximum value of SAR (interpolated) = 17.6 W/kg

**Pin=100mW/Zoom Scan (7x7x12)/Cube 0:** Measurement grid: dx=4mm, dy=4mm, dz=2mm  
Reference Value = 67.30 V/m; Power Drift = 0.11 dB  
Peak SAR (extrapolated) = 30.2 W/kg  
**SAR(1 g) = 7.74 W/kg; SAR(10 g) = 2.24 W/kg**  
Maximum value of SAR (measured) = 19.3 W/kg

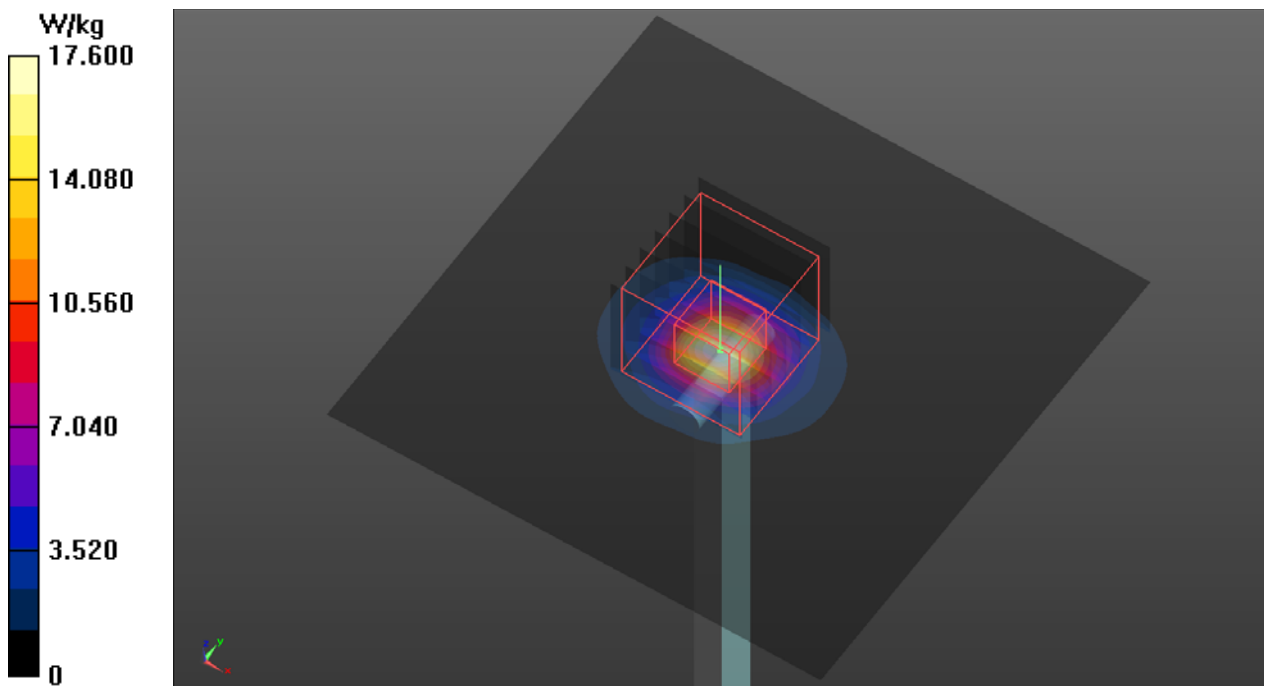

## System Check\_H5600\_190626

**DUT: Dipole 5 GHz; Type: D5GHzV2; SN: 1019**

Communication System: CW; Frequency: 5600 MHz; Duty Cycle: 1:1

Medium: H34T60N2\_0626 Medium parameters used:  $f = 5600$  MHz;  $\sigma = 4.897$  S/m;  $\epsilon_r = 35.581$ ;  $\rho = 1000$  kg/m<sup>3</sup>

Ambient Temperature : 23.6 °C ; Liquid Temperature : 23.2 °C

DASY5 Configuration:

- Probe: EX3DV4 - SN7375; ConvF(4.69, 4.69, 4.69); Calibrated: 2018/12/13
- Sensor-Surface: 1.4mm (Mechanical Surface Detection)
- Electronics: DAE4 Sn1277; Calibrated: 2019/01/24
- Phantom: ELI Phantom\_1204; Type: QDOVA;
- Measurement SW: DASY52, Version 52.10 (2); SEMCAD X Version 14.6.12 (7450)

**Pin=100mW/Area Scan (91x91x1):** Interpolated grid: dx=1.000 mm, dy=1.000 mm  
Maximum value of SAR (interpolated) = 19.9 W/kg

**Pin=100mW/Zoom Scan (7x7x12)/Cube 0:** Measurement grid: dx=4mm, dy=4mm, dz=2mm  
Reference Value = 63.64 V/m; Power Drift = 0.03 dB  
Peak SAR (extrapolated) = 35.4 W/kg  
**SAR(1 g) = 8.17 W/kg; SAR(10 g) = 2.32 W/kg**  
Maximum value of SAR (measured) = 21.2 W/kg

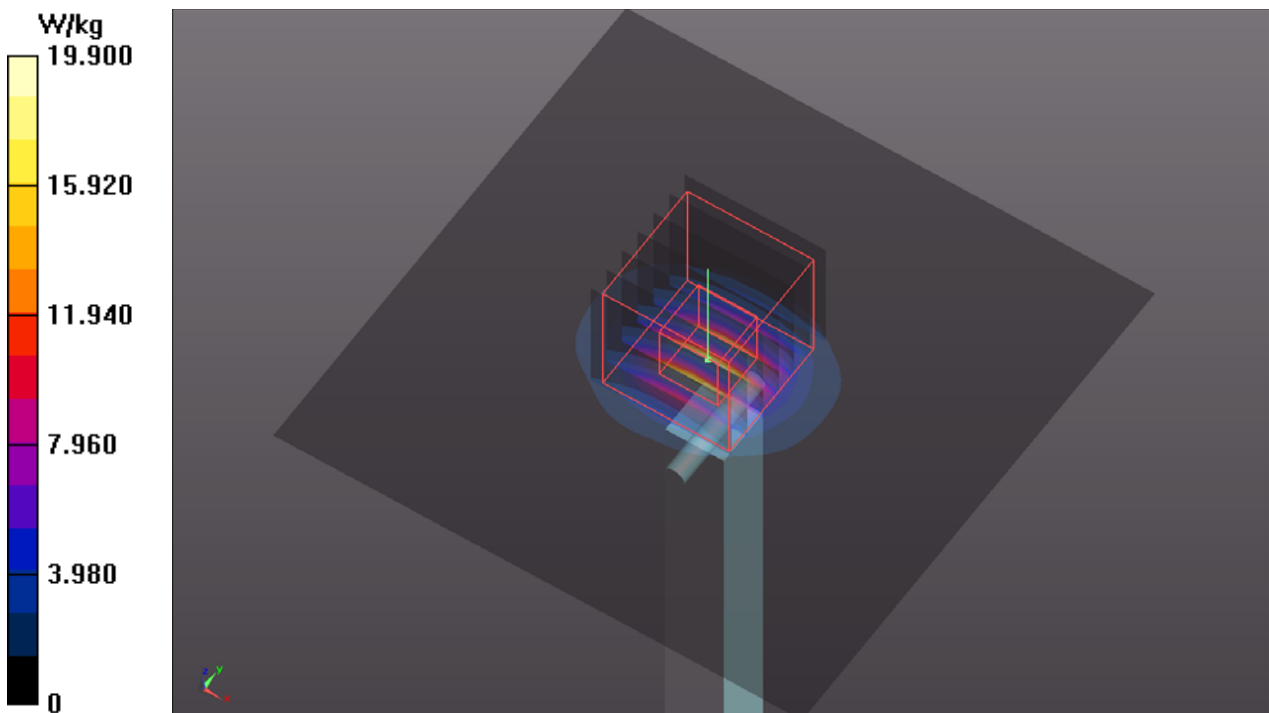

## System Check\_H5750\_190627

**DUT: Dipole 5 GHz; Type: D5GHzV2; SN: 1019**

Communication System: CW; Frequency: 5750 MHz; Duty Cycle: 1:1

Medium: H34T60N2\_0627 Medium parameters used:  $f = 5750$  MHz;  $\sigma = 5.04$  S/m;  $\epsilon_r = 35.375$ ;  $\rho = 1000$  kg/m<sup>3</sup>

Ambient Temperature : 23.5 °C ; Liquid Temperature : 23.3 °C

DASY5 Configuration:

- Probe: EX3DV4 - SN7375; ConvF(4.85, 4.85, 4.85); Calibrated: 2018/12/13
- Sensor-Surface: 1.4mm (Mechanical Surface Detection)
- Electronics: DAE4 Sn1277; Calibrated: 2019/01/24
- Phantom: ELI Phantom\_1204; Type: QDOVA;
- Measurement SW: DASY52, Version 52.10 (2); SEMCAD X Version 14.6.12 (7450)

**Pin=100mW/Area Scan (91x91x1):** Interpolated grid: dx=1.000 mm, dy=1.000 mm

Maximum value of SAR (interpolated) = 20.2 W/kg

**Pin=100mW/Zoom Scan (7x7x12)/Cube 0:** Measurement grid: dx=4mm, dy=4mm, dz=2mm

Reference Value = 72.20 V/m; Power Drift = 0.03 dB

Peak SAR (extrapolated) = 37.0 W/kg

**SAR(1 g) = 8.19 W/kg; SAR(10 g) = 2.34 W/kg**

Maximum value of SAR (measured) = 21.5 W/kg

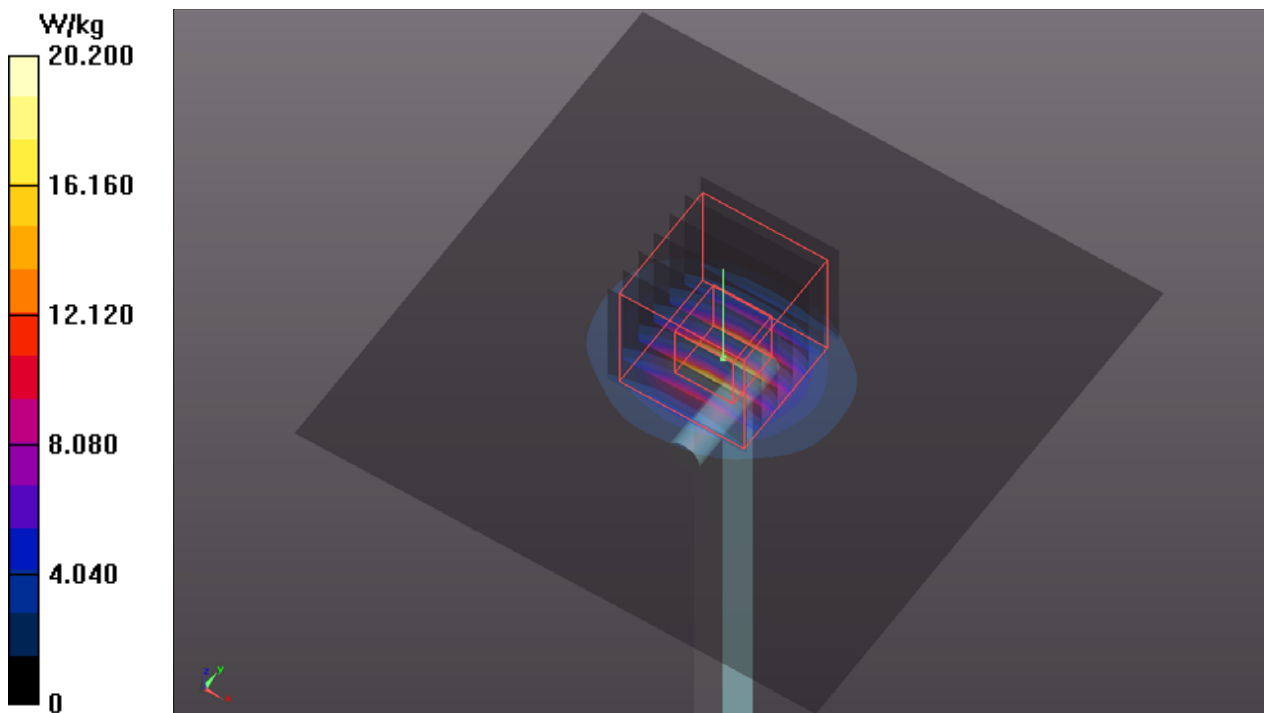

## Appendix B. SAR Plots of SAR Measurement

The SAR plots for highest measured SAR in each exposure configuration, wireless mode and frequency band combination, and measured SAR > 1.5 W/kg are shown as follows.



## P01 WCDMA II\_RMC12.2K\_Top Side\_0cm\_Ch9262\_Sku2

### DUT: 190506C08

Communication System: WCDMA; Frequency: 1852.4 MHz; Duty Cycle: 1:1  
Medium: H16T20N1\_0627 Medium parameters used:  $f = 1852.4$  MHz;  $\sigma = 1.416$  S/m;  $\epsilon_r = 39.904$ ;  
 $\rho = 1000$  kg/m<sup>3</sup>  
Ambient Temperature : 23.5 °C ; Liquid Temperature : 23.3 °C

#### DASY5 Configuration:

- Probe: EX3DV4 - SN7375; ConvF(8.26, 8.26, 8.26); Calibrated: 2018/12/13
- Sensor-Surface: 1.4mm (Mechanical Surface Detection)
- Electronics: DAE4 Sn1277; Calibrated: 2019/01/24
- Phantom: ELI Phantom\_1204; Type: QDOVA;
- Measurement SW: DASY52, Version 52.10 (2); SEMCAD X Version 14.6.12 (7450)

- **Area Scan (71x231x1):** Interpolated grid: dx=1.500 mm, dy=1.500 mm  
Maximum value of SAR (interpolated) = 1.05 W/kg

- **Zoom Scan (5x5x7)/Cube 0:** Measurement grid: dx=8mm, dy=8mm, dz=5mm  
Reference Value = 26.95 V/m; Power Drift = -0.03 dB  
Peak SAR (extrapolated) = 2.42 W/kg  
**SAR(1 g) = 1.08 W/kg; SAR(10 g) = 0.479 W/kg**  
Maximum value of SAR (measured) = 1.84 W/kg

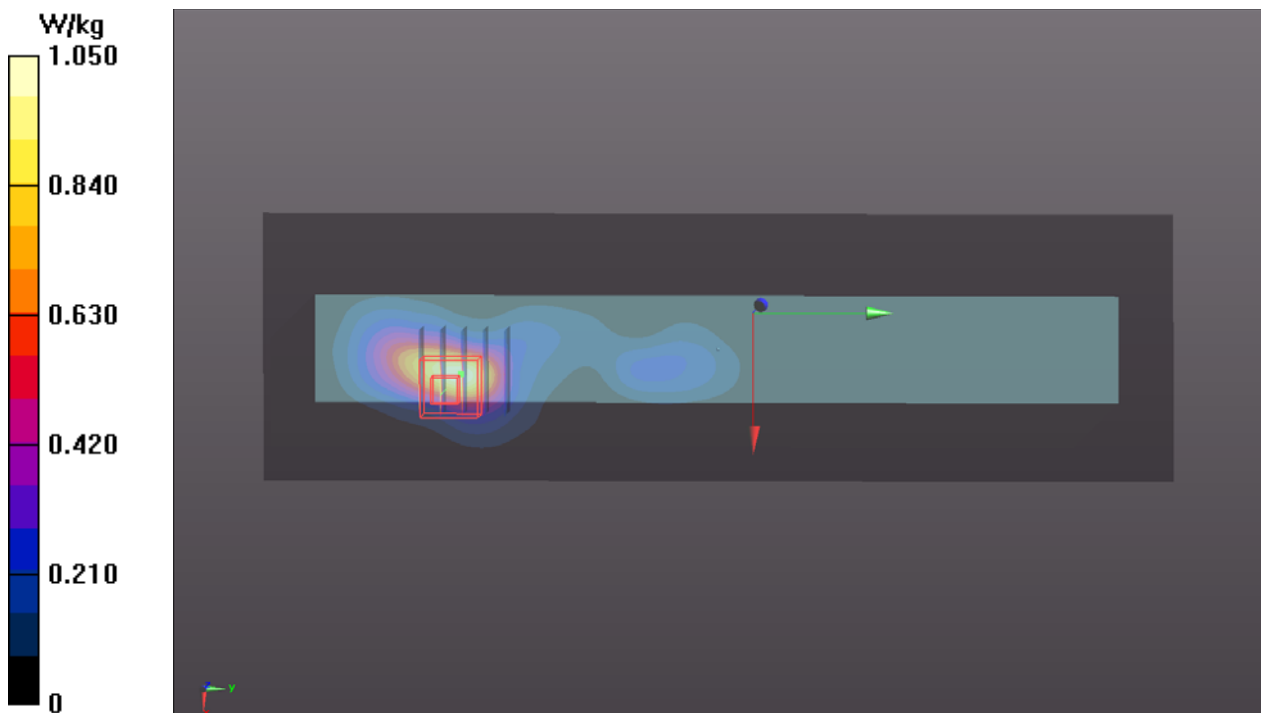

## P24 WCDMA IV\_RMC12.2K\_Top Side\_0cm\_Ch1312\_Sku2

### DUT: 190506C08

Communication System: WCDMA; Frequency: 1712.4 MHz; Duty Cycle: 1:1  
Medium: H16T20N1\_0703 Medium parameters used:  $f = 1712.4$  MHz;  $\sigma = 1.288$  S/m;  $\epsilon_r = 39.879$ ;  
 $\rho = 1000$  kg/m<sup>3</sup>  
Ambient Temperature : 23.7 °C ; Liquid Temperature : 23.3 °C

#### DASY5 Configuration:

- Probe: EX3DV4 - SN7472; ConvF(8.79, 8.79, 8.79); Calibrated: 2018/08/29
- Sensor-Surface: 1.4mm (Mechanical Surface Detection)
- Electronics: DAE3 Sn579; Calibrated: 2018/08/27
- Phantom: ELI Phantom\_1204; Type: QDOVA;
- Measurement SW: DASY52, Version 52.10 (2); SEMCAD X Version 14.6.12 (7450)

- **Area Scan (101x231x1):** Interpolated grid: dx=1.500 mm, dy=1.500 mm  
Maximum value of SAR (interpolated) = 1.82 W/kg

- **Zoom Scan (5x5x7)/Cube 0:** Measurement grid: dx=8mm, dy=8mm, dz=5mm  
Reference Value = 36.64 V/m; Power Drift = 0.18 dB  
Peak SAR (extrapolated) = 2.26 W/kg  
**SAR(1 g) = 1.08 W/kg; SAR(10 g) = 0.540 W/kg**  
Maximum value of SAR (measured) = 1.89 W/kg

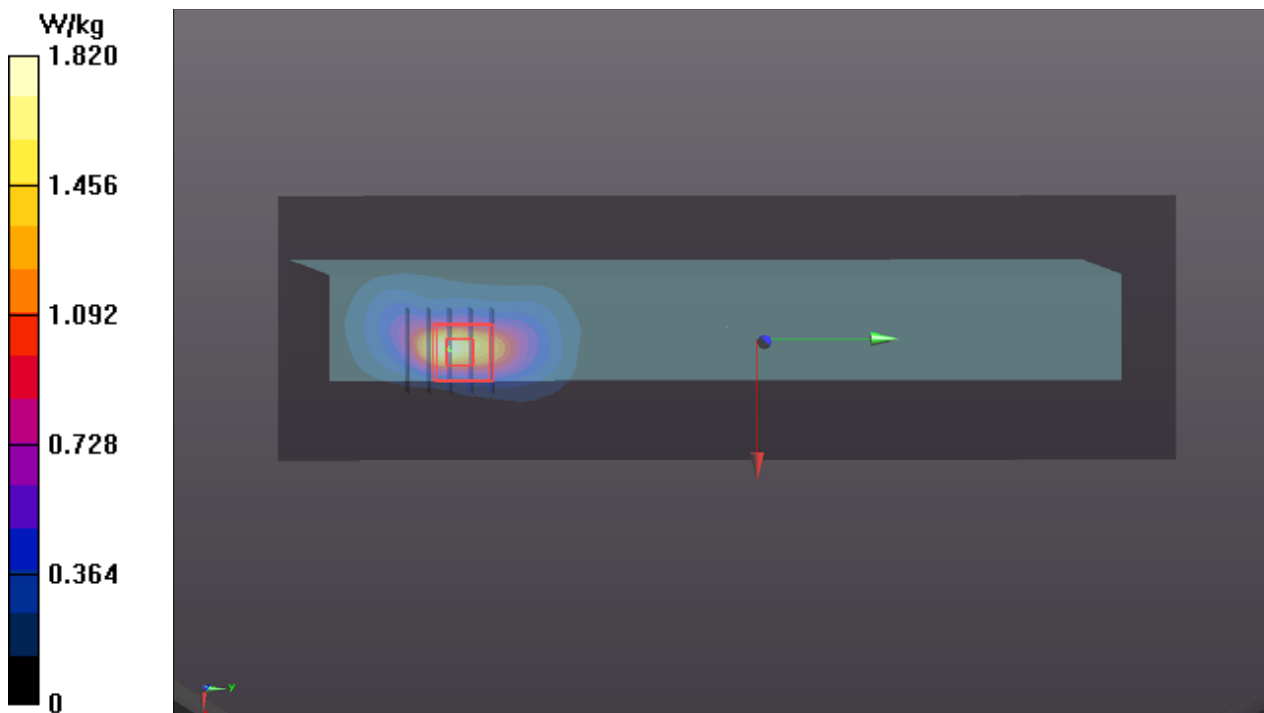

### P03 WCDMA V\_RMC12.2K\_Top Side\_0cm\_Ch4233\_Sku2

#### DUT: 190506C08

Communication System: WCDMA; Frequency: 846.6 MHz; Duty Cycle: 1:1  
Medium: H07T10N1\_0629 Medium parameters used:  $f = 847$  MHz;  $\sigma = 0.914$  S/m;  $\epsilon_r = 41.143$ ;  $\rho = 1000$  kg/m<sup>3</sup>  
Ambient Temperature : 23.6 °C ; Liquid Temperature : 23.2 °C

#### DASY5 Configuration:

- Probe: EX3DV4 - SN7375; ConvF(10.13, 10.13, 10.13); Calibrated: 2018/12/13
- Sensor-Surface: 1.4mm (Mechanical Surface Detection)
- Electronics: DAE4 Sn1277; Calibrated: 2019/01/24
- Phantom: ELI Phantom\_1204; Type: QDOVA;
- Measurement SW: DASY52, Version 52.10 (2); SEMCAD X Version 14.6.12 (7450)

- **Area Scan (71x231x1):** Interpolated grid: dx=1.500 mm, dy=1.500 mm  
Maximum value of SAR (interpolated) = 0.610 W/kg

- **Zoom Scan (5x5x7)/Cube 0:** Measurement grid: dx=8mm, dy=8mm, dz=5mm  
Reference Value = 24.62 V/m; Power Drift = -0.08 dB  
Peak SAR (extrapolated) = 1.43 W/kg  
**SAR(1 g) = 0.677 W/kg; SAR(10 g) = 0.361 W/kg**  
Maximum value of SAR (measured) = 1.02 W/kg

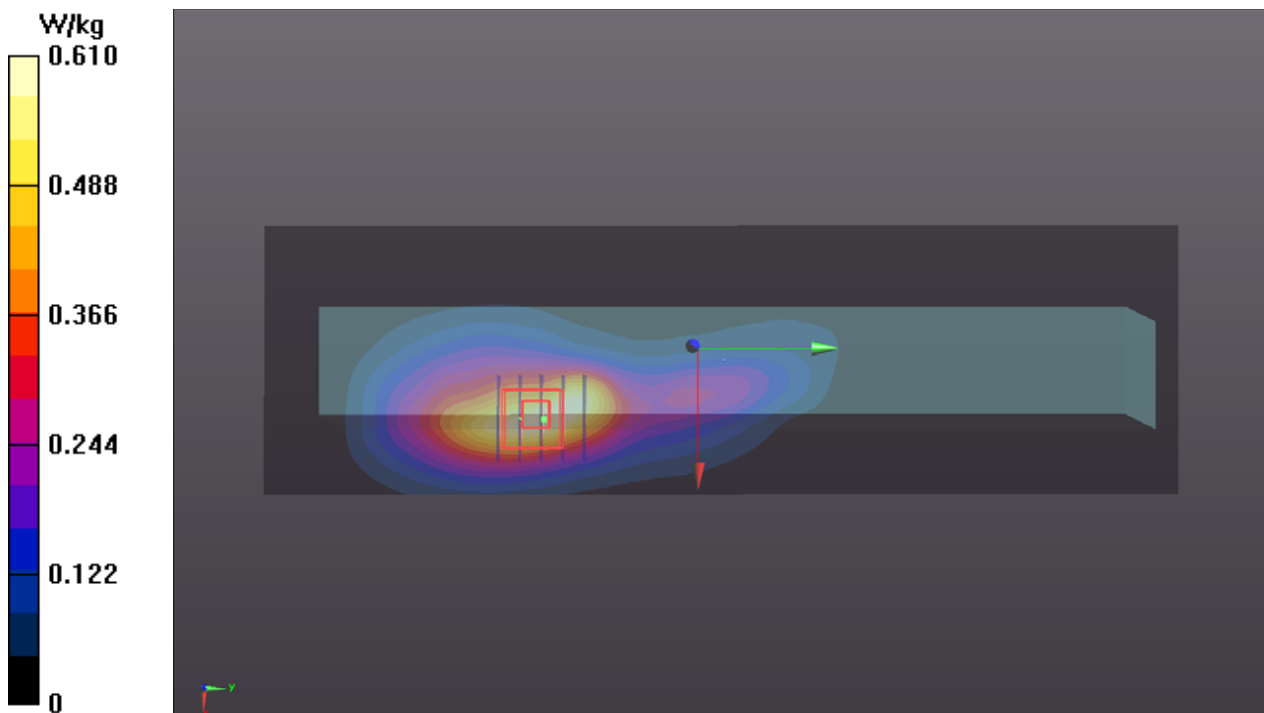

## P04 LTE 2\_QPSK20M\_Top Side\_0cm\_Ch18700\_1RB\_OS0\_Sku2

### DUT: 190506C08

Communication System: LTE; Frequency: 1860 MHz; Duty Cycle: 1:1

Medium: H16T20N1\_0629 Medium parameters used:  $f = 1860$  MHz;  $\sigma = 1.421$  S/m;  $\epsilon_r = 39.839$ ;  $\rho = 1000$  kg/m<sup>3</sup>

Ambient Temperature : 23.6 °C ; Liquid Temperature : 23.2 °C

#### DASY5 Configuration:

- Probe: EX3DV4 - SN7375; ConvF(8.26, 8.26, 8.26); Calibrated: 2018/12/13
- Sensor-Surface: 1.4mm (Mechanical Surface Detection)
- Electronics: DAE4 Sn1277; Calibrated: 2019/01/24
- Phantom: ELI Phantom\_1204; Type: QDOVA;
- Measurement SW: DASY52, Version 52.10 (2); SEMCAD X Version 14.6.12 (7450)

- **Area Scan (71x231x1):** Interpolated grid: dx=1.500 mm, dy=1.500 mm

Maximum value of SAR (interpolated) = 0.866 W/kg

- **Zoom Scan (5x5x7)/Cube 0:** Measurement grid: dx=8mm, dy=8mm, dz=5mm

Reference Value = 23.97 V/m; Power Drift = -0.05 dB

Peak SAR (extrapolated) = 2.49 W/kg

**SAR(1 g) = 1.07 W/kg; SAR(10 g) = 0.432 W/kg**

Maximum value of SAR (measured) = 1.84 W/kg

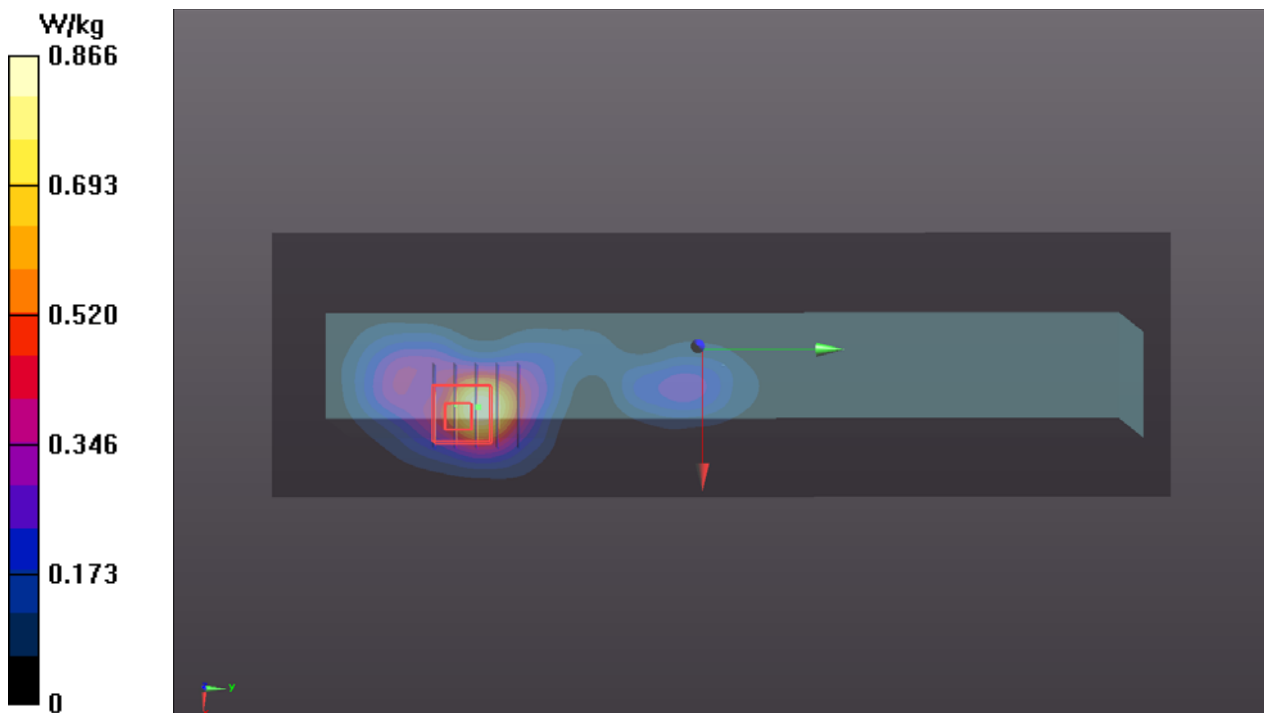

## P05 LTE 7\_QPSK20M\_Top Side\_0cm\_Ch20850\_1RB\_OS0\_Sku2

### DUT: 190506C08

Communication System: LTE; Frequency: 2510 MHz; Duty Cycle: 1:1  
Medium: H19T27N1\_0629 Medium parameters used:  $f = 2510$  MHz;  $\sigma = 1.911$  S/m;  $\epsilon_r = 38.557$ ;  $\rho = 1000$  kg/m<sup>3</sup>  
Ambient Temperature : 23.6 °C ; Liquid Temperature : 23.2 °C

#### DASY5 Configuration:

- Probe: EX3DV4 - SN7375; ConvF(7.42, 7.42, 7.42); Calibrated: 2018/12/13
- Sensor-Surface: 1.4mm (Mechanical Surface Detection)
- Electronics: DAE4 Sn1277; Calibrated: 2019/01/24
- Phantom: ELI Phantom\_1204; Type: QDOVA;
- Measurement SW: DASY52, Version 52.10 (2); SEMCAD X Version 14.6.12 (7450)

- **Area Scan (91x291x1):** Interpolated grid: dx=1.200 mm, dy=1.200 mm  
Maximum value of SAR (interpolated) = 0.525 W/kg

- **Zoom Scan (5x5x7)/Cube 0:** Measurement grid: dx=8mm, dy=8mm, dz=5mm  
Reference Value = 14.25 V/m; Power Drift = -0.04 dB  
Peak SAR (extrapolated) = 1.71 W/kg  
**SAR(1 g) = 0.717 W/kg; SAR(10 g) = 0.279 W/kg**  
Maximum value of SAR (measured) = 1.44 W/kg

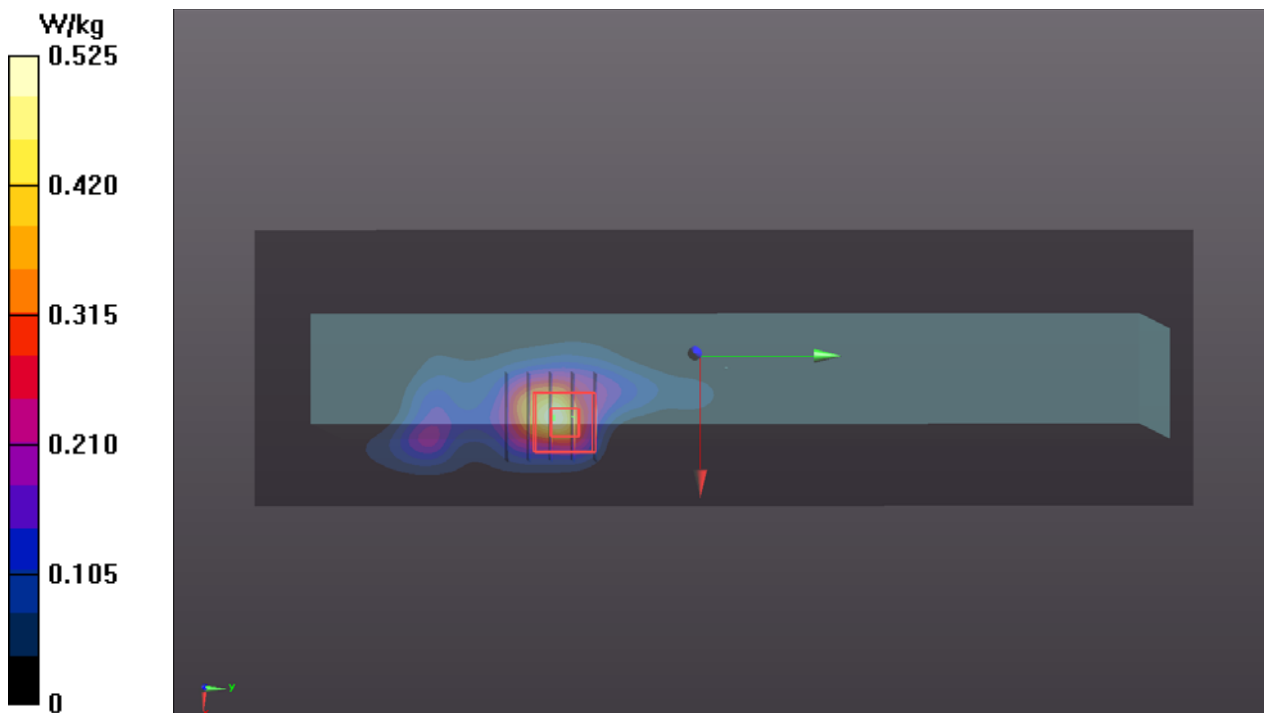

## P06 LTE 12\_QPSK10M\_Top Side\_0cm\_Ch23060\_1RB\_OS0\_Sku2

### DUT: 190506C08

Communication System: LTE; Frequency: 704 MHz; Duty Cycle: 1:1

Medium: H06T09N1\_0629 Medium parameters used:  $f = 704$  MHz;  $\sigma = 0.851$  S/m;  $\epsilon_r = 44.007$ ;  $\rho = 1000$  kg/m<sup>3</sup>

Ambient Temperature : 23.6 °C ; Liquid Temperature : 23.2 °C

#### DASY5 Configuration:

- Probe: EX3DV4 - SN7375; ConvF(10.35, 10.35, 10.35); Calibrated: 2018/12/13
- Sensor-Surface: 1.4mm (Mechanical Surface Detection)
- Electronics: DAE4 Sn1277; Calibrated: 2019/01/24
- Phantom: ELI Phantom\_1204; Type: QDOVA;
- Measurement SW: DASY52, Version 52.10 (2); SEMCAD X Version 14.6.12 (7450)

- **Area Scan (71x231x1):** Interpolated grid: dx=1.500 mm, dy=1.500 mm

Maximum value of SAR (interpolated) = 0.758 W/kg

- **Zoom Scan (5x5x7)/Cube 0:** Measurement grid: dx=8mm, dy=8mm, dz=5mm

Reference Value = 27.68 V/m; Power Drift = -0.15 dB

Peak SAR (extrapolated) = 1.60 W/kg

**SAR(1 g) = 0.758 W/kg; SAR(10 g) = 0.388 W/kg**

Maximum value of SAR (measured) = 1.33 W/kg

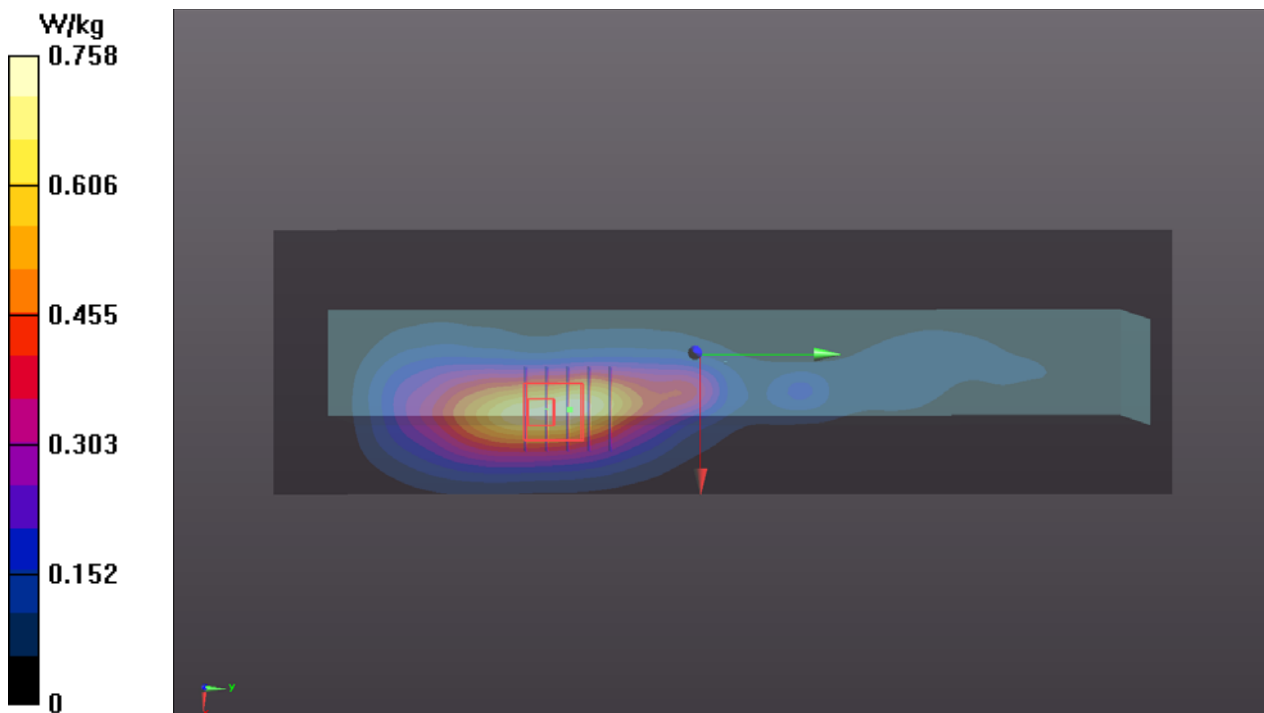

## P07 LTE 13\_QPSK10M\_Top Side\_0cm\_Ch23230\_1RB\_OS0\_Sku2

### DUT: 190506C08

Communication System: LTE; Frequency: 782 MHz; Duty Cycle: 1:1

Medium: H07T10N1\_0629 Medium parameters used:  $f = 782 \text{ MHz}$ ;  $\sigma = 0.856 \text{ S/m}$ ;  $\epsilon_r = 41.929$ ;  $\rho = 1000 \text{ kg/m}^3$

Ambient Temperature :  $23.6 \text{ }^\circ\text{C}$  ; Liquid Temperature :  $23.2 \text{ }^\circ\text{C}$

#### DASY5 Configuration:

- Probe: EX3DV4 - SN7375; ConvF(10.35, 10.35, 10.35); Calibrated: 2018/12/13
- Sensor-Surface: 1.4mm (Mechanical Surface Detection)
- Electronics: DAE4 Sn1277; Calibrated: 2019/01/24
- Phantom: ELI Phantom\_1204; Type: QDOVA;
- Measurement SW: DASY52, Version 52.10 (2); SEMCAD X Version 14.6.12 (7450)

- **Area Scan (71x231x1):** Interpolated grid:  $dx=1.500 \text{ mm}$ ,  $dy=1.500 \text{ mm}$

Maximum value of SAR (interpolated) =  $0.831 \text{ W/kg}$

- **Zoom Scan (5x5x7)/Cube 0:** Measurement grid:  $dx=8\text{mm}$ ,  $dy=8\text{mm}$ ,  $dz=5\text{mm}$

Reference Value =  $30.07 \text{ V/m}$ ; Power Drift =  $-0.07 \text{ dB}$

Peak SAR (extrapolated) =  $1.78 \text{ W/kg}$

**SAR(1 g) =  $0.900 \text{ W/kg}$ ; SAR(10 g) =  $0.501 \text{ W/kg}$**

Maximum value of SAR (measured) =  $1.48 \text{ W/kg}$

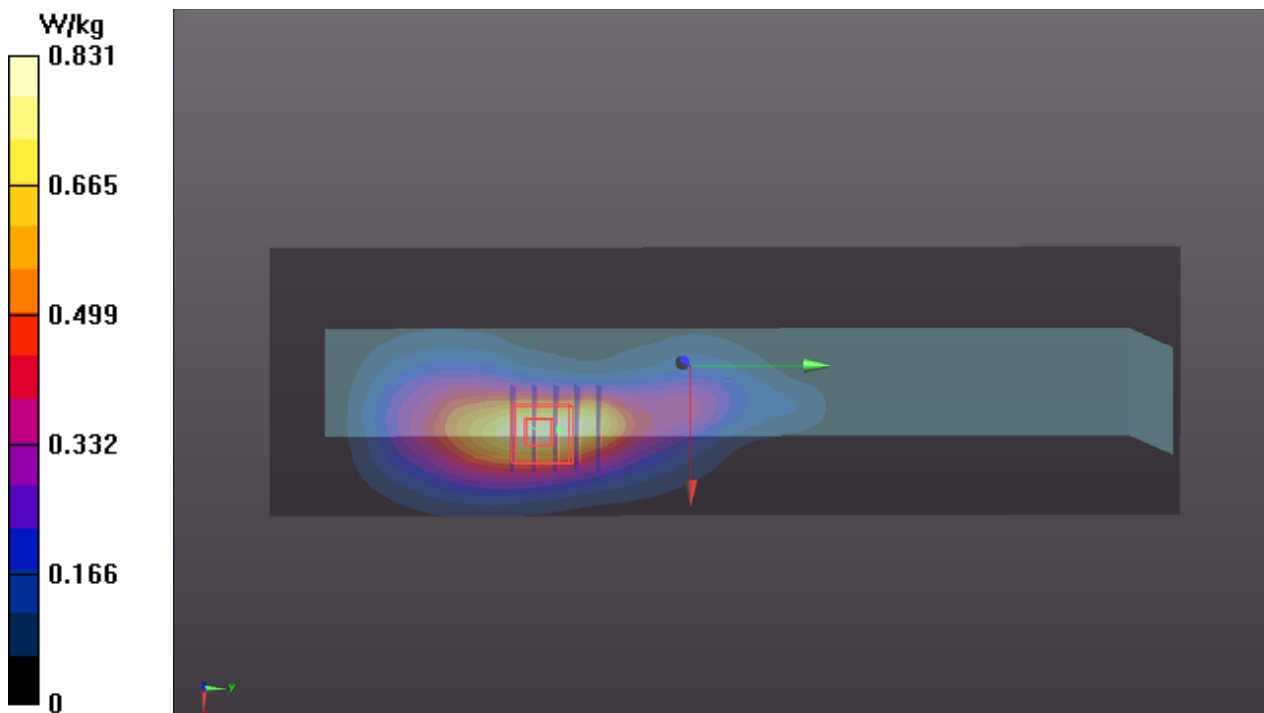

### P08 LTE 14\_QPSK10M\_Top Side\_0cm\_Ch23330\_25RB\_OS25\_Sku2

#### DUT: 190506C08

Communication System: LTE; Frequency: 793 MHz; Duty Cycle: 1:1

Medium: H07T10N1\_0629 Medium parameters used:  $f = 793$  MHz;  $\sigma = 0.865$  S/m;  $\epsilon_r = 41.793$ ;  $\rho = 1000$  kg/m<sup>3</sup>

Ambient Temperature : 23.6 °C ; Liquid Temperature : 23.2 °C

#### DASY5 Configuration:

- Probe: EX3DV4 - SN7375; ConvF(10.35, 10.35, 10.35); Calibrated: 2018/12/13
- Sensor-Surface: 1.4mm (Mechanical Surface Detection)
- Electronics: DAE4 Sn1277; Calibrated: 2019/01/24
- Phantom: ELI Phantom\_1204; Type: QDOVA;
- Measurement SW: DASY52, Version 52.10 (2); SEMCAD X Version 14.6.12 (7450)

- **Area Scan (71x231x1):** Interpolated grid: dx=1.500 mm, dy=1.500 mm

Maximum value of SAR (interpolated) = 0.798 W/kg

- **Zoom Scan (5x5x7)/Cube 0:** Measurement grid: dx=8mm, dy=8mm, dz=5mm

Reference Value = 28.95 V/m; Power Drift = -0.02 dB

Peak SAR (extrapolated) = 1.69 W/kg

**SAR(1 g) = 0.837 W/kg; SAR(10 g) = 0.463 W/kg**

Maximum value of SAR (measured) = 1.40 W/kg

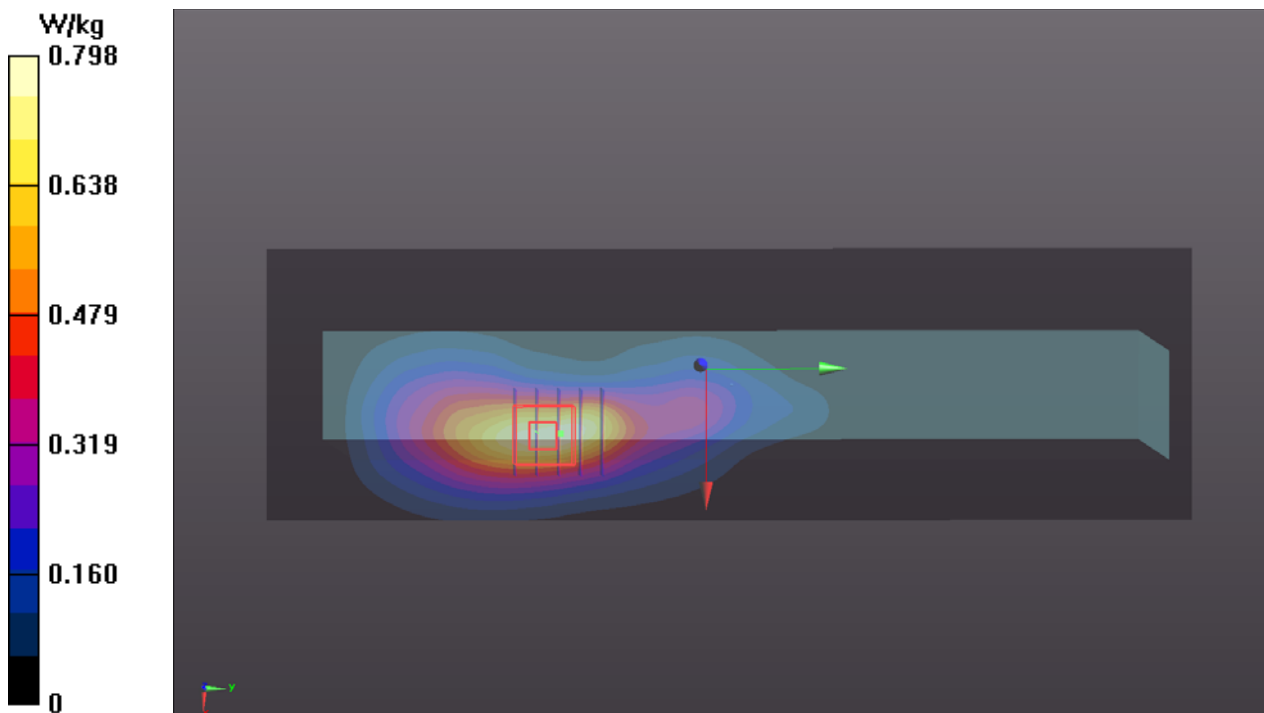



## P09 LTE 26\_QPSK15M\_Top Side\_0cm\_Ch26965\_36RB\_OS19\_Sku2

### DUT: 190506C08

Communication System: LTE; Frequency: 841.5 MHz; Duty Cycle: 1:1

Medium: H07T10N1\_0629 Medium parameters used:  $f = 841.5$  MHz;  $\sigma = 0.909$  S/m;  $\epsilon_r = 41.207$ ;  $\rho = 1000$  kg/m<sup>3</sup>

Ambient Temperature : 23.6 °C ; Liquid Temperature : 23.2 °C

#### DASY5 Configuration:

- Probe: EX3DV4 - SN7375; ConvF(10.13, 10.13, 10.13); Calibrated: 2018/12/13
- Sensor-Surface: 1.4mm (Mechanical Surface Detection)
- Electronics: DAE4 Sn1277; Calibrated: 2019/01/24
- Phantom: ELI Phantom\_1204; Type: QDOVA;
- Measurement SW: DASY52, Version 52.10 (2); SEMCAD X Version 14.6.12 (7450)

- **Area Scan (71x231x1):** Interpolated grid: dx=1.500 mm, dy=1.500 mm

Maximum value of SAR (interpolated) = 0.760 W/kg

- **Zoom Scan (5x5x7)/Cube 0:** Measurement grid: dx=8mm, dy=8mm, dz=5mm

Reference Value = 28.48 V/m; Power Drift = -0.06 dB

Peak SAR (extrapolated) = 1.56 W/kg

**SAR(1 g) = 0.789 W/kg; SAR(10 g) = 0.437 W/kg**

Maximum value of SAR (measured) = 1.26 W/kg

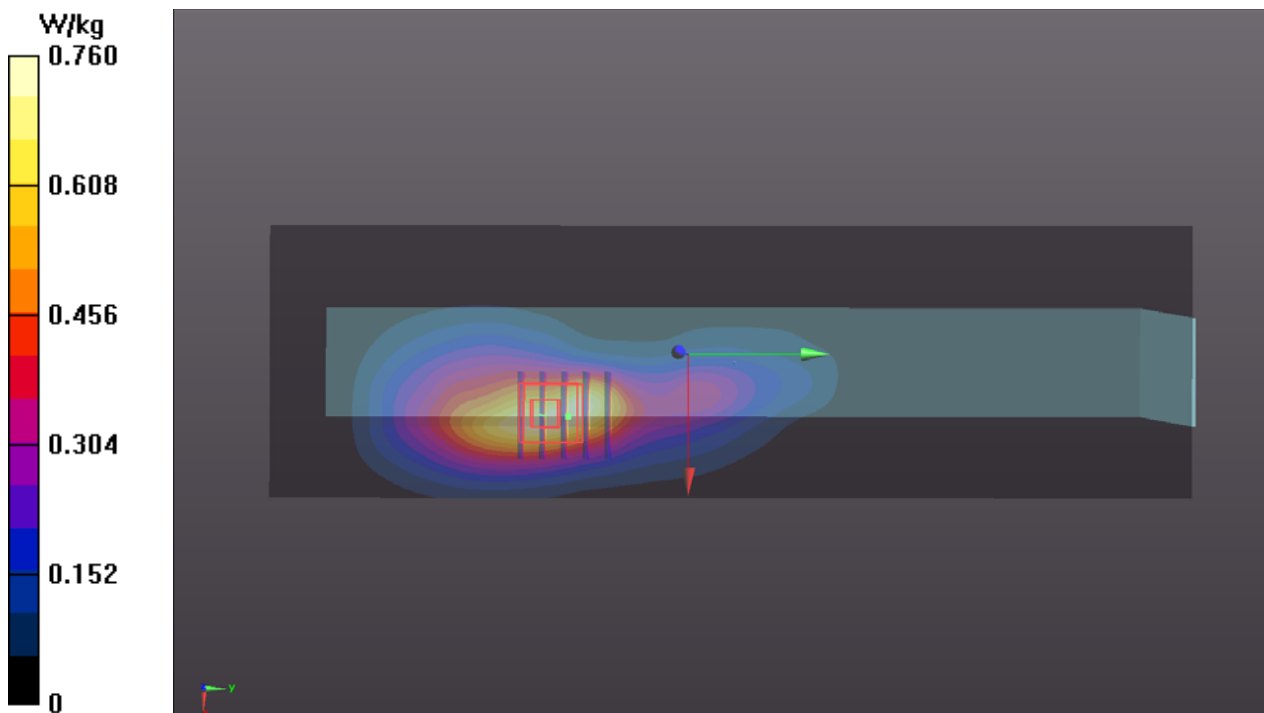

## P10 LTE 41\_QPSK20M\_Top Side\_0cm\_Ch41490\_1RB\_OS0\_Sku2

### DUT: 190506C08

Communication System: LTE TDD CF0; Frequency: 2680 MHz; Duty Cycle: 1:1.58  
Medium: H19T27N1\_0629 Medium parameters used:  $f = 2680$  MHz;  $\sigma = 2.08$  S/m;  $\epsilon_r = 37.931$ ;  $\rho = 1000$  kg/m<sup>3</sup>  
Ambient Temperature : 23.6 °C ; Liquid Temperature : 23.2 °C

#### DASY5 Configuration:

- Probe: EX3DV4 - SN7375; ConvF(7.42, 7.42, 7.42); Calibrated: 2018/12/13
- Sensor-Surface: 1.4mm (Mechanical Surface Detection)
- Electronics: DAE4 Sn1277; Calibrated: 2019/01/24
- Phantom: ELI Phantom\_1204; Type: QDOVA;
- Measurement SW: DASY52, Version 52.10 (2); SEMCAD X Version 14.6.12 (7450)

- **Area Scan (91x291x1):** Interpolated grid: dx=1.200 mm, dy=1.200 mm  
Maximum value of SAR (interpolated) = 0.495 W/kg

- **Zoom Scan (5x5x7)/Cube 0:** Measurement grid: dx=8mm, dy=8mm, dz=5mm  
Reference Value = 9.927 V/m; Power Drift = -0.15 dB  
Peak SAR (extrapolated) = 0.723 W/kg  
**SAR(1 g) = 0.316 W/kg; SAR(10 g) = 0.127 W/kg**  
Maximum value of SAR (measured) = 0.583 W/kg

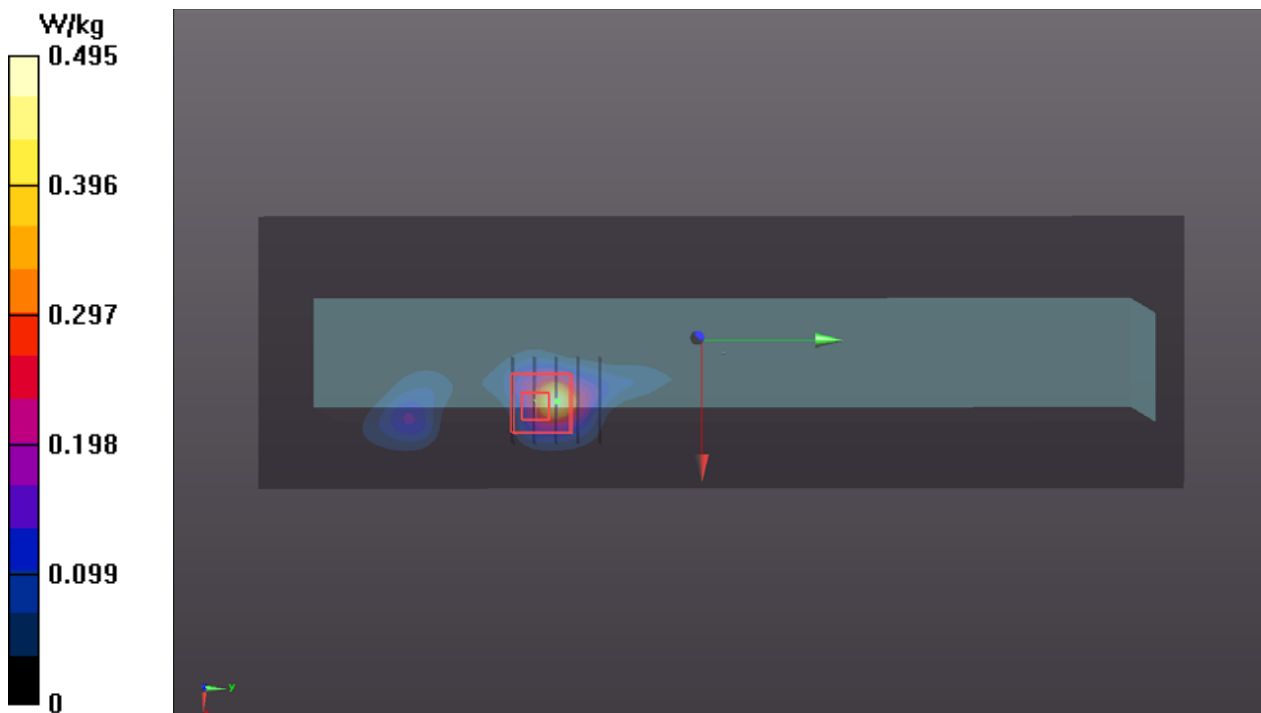

## P11 LTE 66\_QPKS20M\_Top Side\_0cm\_Ch132072\_1RB\_OS0\_Sku2

### DUT: 190506C08

Communication System: LTE; Frequency: 1720 MHz; Duty Cycle: 1:1

Medium: H16T20N1\_0708 Medium parameters used:  $f = 1720$  MHz;  $\sigma = 1.297$  S/m;  $\epsilon_r = 40.465$ ;  $\rho = 1000$  kg/m<sup>3</sup>

Ambient Temperature : 23.6 °C ; Liquid Temperature : 23.2 °C

#### DASY5 Configuration:

- Probe: EX3DV4 - SN7375; ConvF(8.58, 8.58, 8.58); Calibrated: 2018/12/13
- Sensor-Surface: 1.4mm (Mechanical Surface Detection)
- Electronics: DAE4 Sn1277; Calibrated: 2019/01/24
- Phantom: ELI Phantom\_1204; Type: QDOVA;
- Measurement SW: DASY52, Version 52.10 (2); SEMCAD X Version 14.6.12 (7450)

- **Area Scan (71x231x1):** Interpolated grid: dx=1.500 mm, dy=1.500 mm

Maximum value of SAR (interpolated) = 1.27 W/kg

- **Zoom Scan (5x5x7)/Cube 0:** Measurement grid: dx=8mm, dy=8mm, dz=5mm

Reference Value = 31.92 V/m; Power Drift = -0.13 dB

Peak SAR (extrapolated) = 2.51 W/kg

**SAR(1 g) = 1.19 W/kg; SAR(10 g) = 0.663 W/kg**

Maximum value of SAR (measured) = 2.00 W/kg

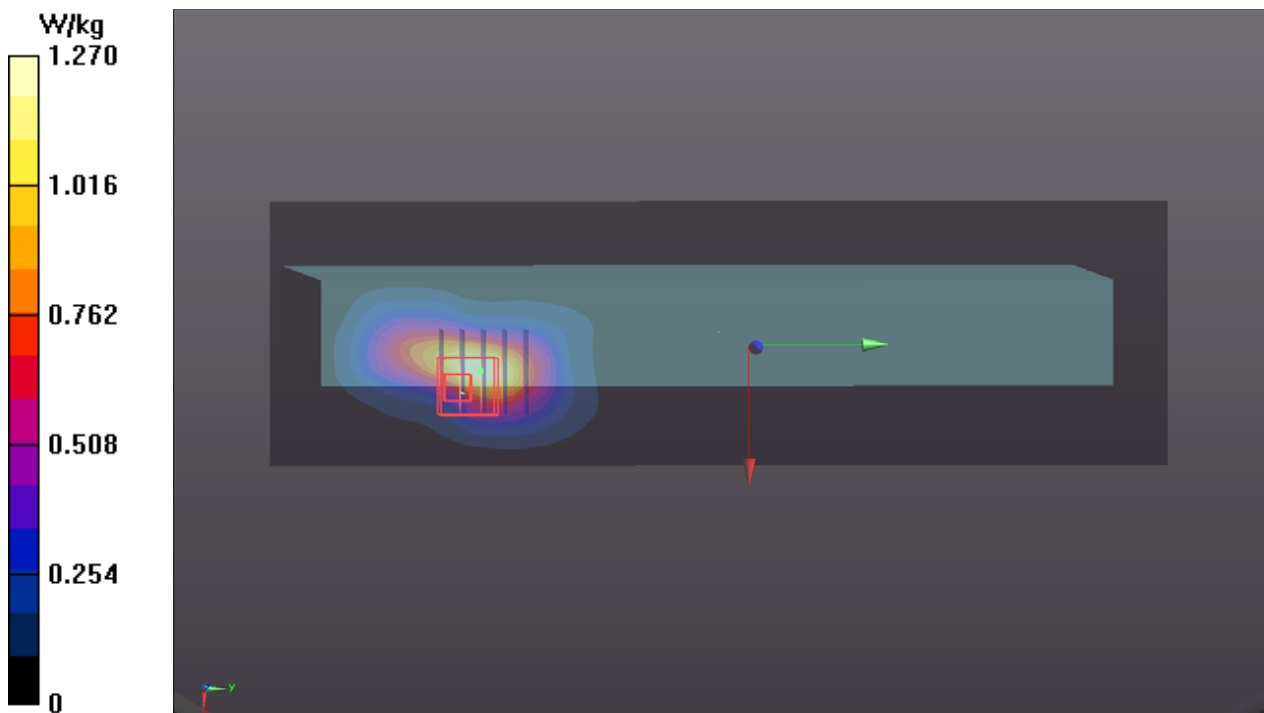

## P12 WLAN2.4G\_802.11b\_Right Side\_0cm\_Ch6\_Sku2\_Ant1

### DUT: 190506C08

Communication System: WLAN\_2.4G; Frequency: 2437 MHz; Duty Cycle: 1:1.03  
Medium: H19T27N1\_0626 Medium parameters used:  $f = 2437$  MHz;  $\sigma = 1.885$  S/m;  $\epsilon_r = 38.326$ ;  $\rho = 1000$  kg/m<sup>3</sup>  
Ambient Temperature : 23.6 °C ; Liquid Temperature : 23.2 °C

#### DASY5 Configuration:

- Probe: EX3DV4 - SN7375; ConvF(7.64, 7.64, 7.64); Calibrated: 2018/12/13
- Sensor-Surface: 1.4mm (Mechanical Surface Detection)
- Electronics: DAE4 Sn1277; Calibrated: 2019/01/24
- Phantom: ELI Phantom\_1204; Type: QDOVA;
- Measurement SW: DASY52, Version 52.10 (2); SEMCAD X Version 14.6.12 (7450)

- **Area Scan (91x241x1):** Interpolated grid: dx=1.200 mm, dy=1.200 mm  
Maximum value of SAR (interpolated) = 0.892 W/kg

- **Zoom Scan (5x5x7)/Cube 0:** Measurement grid: dx=8mm, dy=8mm, dz=5mm  
Reference Value = 22.26 V/m; Power Drift = 0.13 dB  
Peak SAR (extrapolated) = 1.12 W/kg  
**SAR(1 g) = 0.573 W/kg; SAR(10 g) = 0.297 W/kg**  
Maximum value of SAR (measured) = 0.905 W/kg

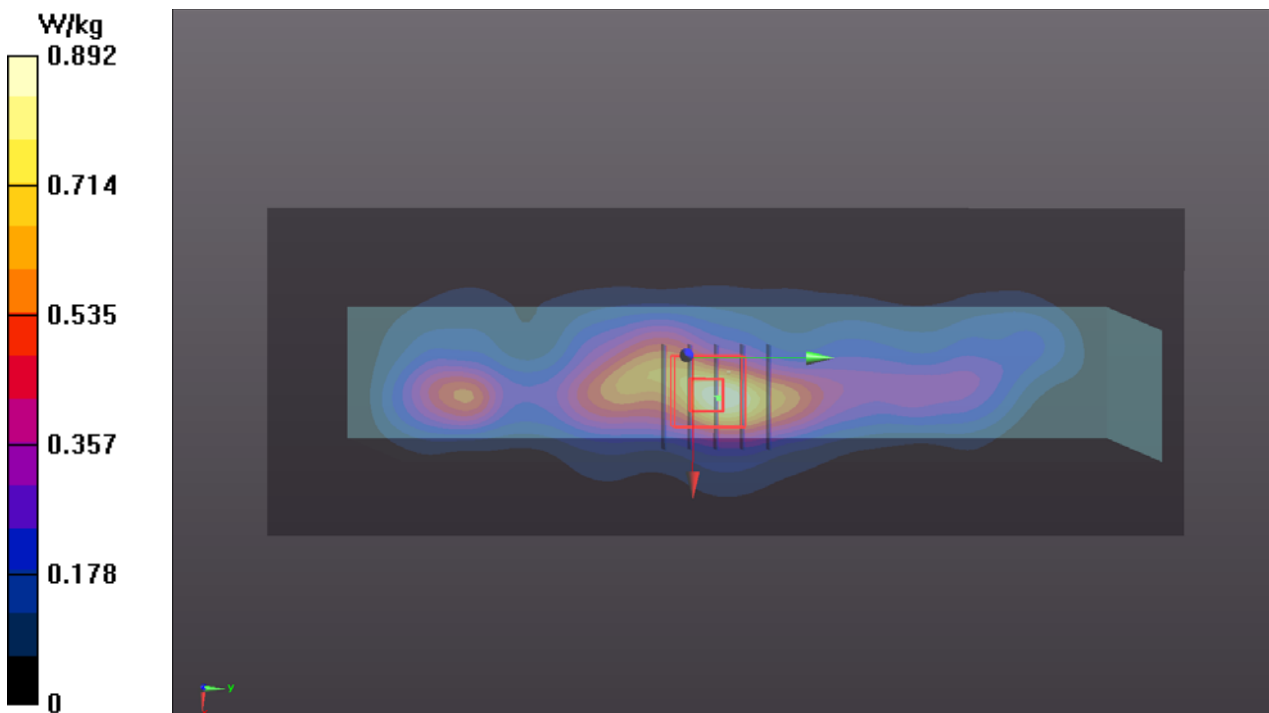

### P13 WLAN5.3G\_802.11a\_Right Side\_0cm\_Ch60\_Sku2\_Ant1

#### DUT: 190506C08

Communication System: WLAN\_5G; Frequency: 5300 MHz; Duty Cycle: 1:1.18  
Medium: H34T60N1\_0704 Medium parameters used:  $f = 5300$  MHz;  $\sigma = 4.789$  S/m;  $\epsilon_r = 36.908$ ;  $\rho = 1000$  kg/m<sup>3</sup>  
Ambient Temperature : 23.7 °C ; Liquid Temperature : 23.4 °C

#### DASY5 Configuration:

- Probe: EX3DV4 - SN7472; ConvF(5.62, 5.62, 5.62); Calibrated: 2018/08/29
- Sensor-Surface: 1.4mm (Mechanical Surface Detection)
- Electronics: DAE3 Sn579; Calibrated: 2018/08/27
- Phantom: ELI Phantom\_1245; Type: QDOVA002AA;
- Measurement SW: DASY52, Version 52.10 (2); SEMCAD X Version 14.6.12 (7470)

- **Area Scan (101x281x1):** Interpolated grid: dx=1.000 mm, dy=1.000 mm  
Maximum value of SAR (interpolated) = 3.25 W/kg

- **Zoom Scan (6x6x12)/Cube 0:** Measurement grid: dx=5mm, dy=5mm, dz=2mm  
Reference Value = 24.42 V/m; Power Drift = -0.05 dB  
Peak SAR (extrapolated) = 4.51 W/kg  
**SAR(1 g) = 1.03 W/kg; SAR(10 g) = 0.328 W/kg**  
Maximum value of SAR (measured) = 2.29 W/kg

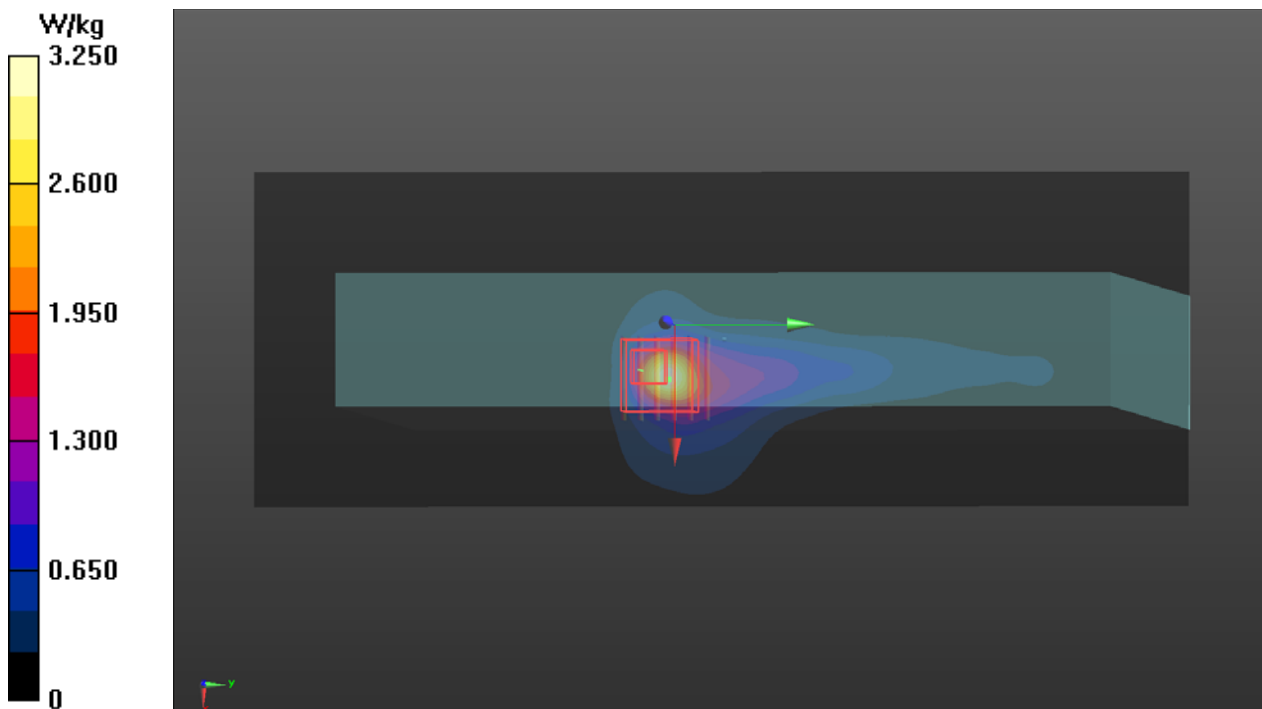

### P14 WLAN5.6G\_802.11n HT40\_Right Side\_0cm\_Ch110\_Sku2\_Ant1

#### DUT: 190506C08

Communication System: WLAN\_5G; Frequency: 5550 MHz; Duty Cycle: 1:1.19

Medium: H34T60N2\_0626 Medium parameters used:  $f = 5550$  MHz;  $\sigma = 4.843$  S/m;  $\epsilon_r = 35.641$ ;  $\rho = 1000$  kg/m<sup>3</sup>

Ambient Temperature : 23.6 °C ; Liquid Temperature : 23.2 °C

#### DASY5 Configuration:

- Probe: EX3DV4 - SN7375; ConvF(4.69, 4.69, 4.69); Calibrated: 2018/12/13
- Sensor-Surface: 1.4mm (Mechanical Surface Detection)
- Electronics: DAE4 Sn1277; Calibrated: 2019/01/24
- Phantom: ELI Phantom\_1204; Type: QDOVA;
- Measurement SW: DASY52, Version 52.10 (2); SEMCAD X Version 14.6.12 (7450)

- **Area Scan (101x281x1):** Interpolated grid: dx=1.000 mm, dy=1.000 mm  
Maximum value of SAR (interpolated) = 2.95 W/kg

- **Zoom Scan (6x6x12)/Cube 0:** Measurement grid: dx=5mm, dy=5mm, dz=2mm  
Reference Value = 23.58 V/m; Power Drift = 0.13 dB  
Peak SAR (extrapolated) = 4.58 W/kg  
**SAR(1 g) = 0.917 W/kg; SAR(10 g) = 0.312 W/kg**  
Maximum value of SAR (measured) = 2.43 W/kg

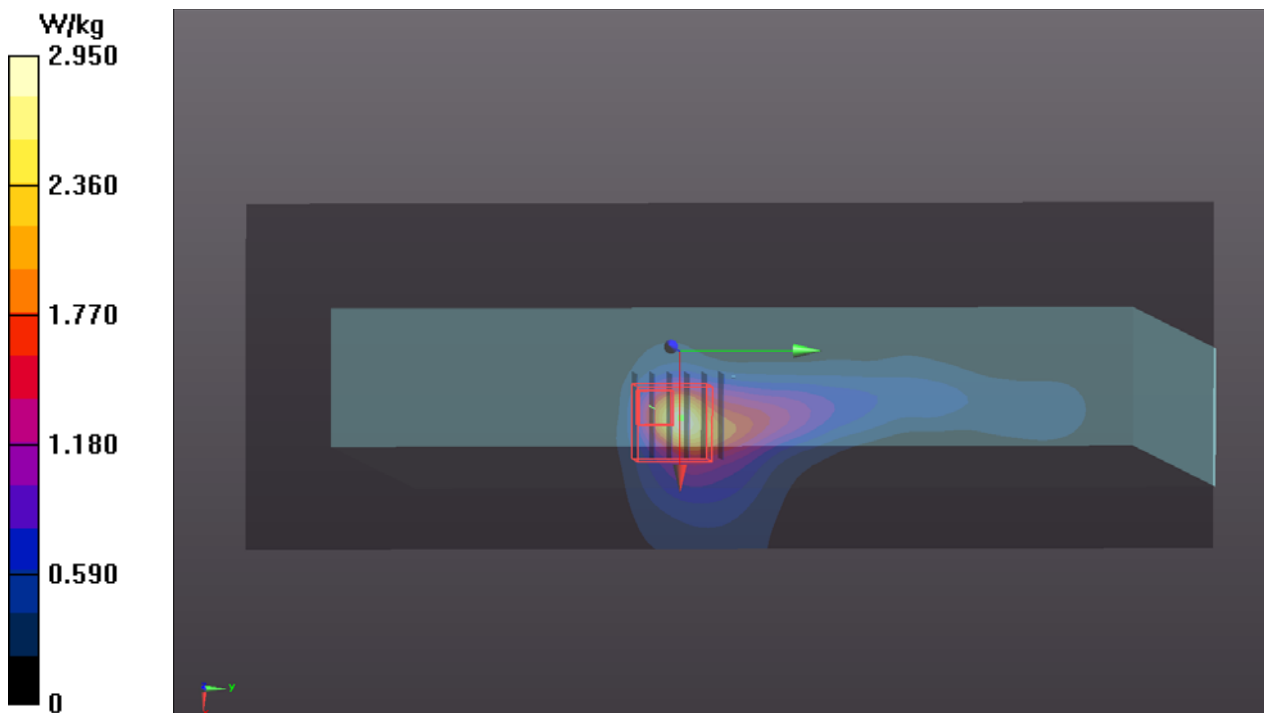

### P15 WLAN5.8G\_802.11n HT20\_Right Side\_0cm\_Ch153\_Sku2\_Ant0+1

#### DUT: 190506C08

Communication System: WLAN\_5G; Frequency: 5765 MHz; Duty Cycle: 1:1.19  
Medium: H34T60N2\_0627 Medium parameters used:  $f = 5765$  MHz;  $\sigma = 5.052$  S/m;  $\epsilon_r = 35.349$ ;  $\rho = 1000$  kg/m<sup>3</sup>  
Ambient Temperature : 23.5 °C ; Liquid Temperature : 23.3 °C

#### DASY5 Configuration:

- Probe: EX3DV4 - SN7375; ConvF(4.85, 4.85, 4.85); Calibrated: 2018/12/13
- Sensor-Surface: 1.4mm (Mechanical Surface Detection)
- Electronics: DAE4 Sn1277; Calibrated: 2019/01/24
- Phantom: ELI Phantom\_1204; Type: QDOVA;
- Measurement SW: DASY52, Version 52.10 (2); SEMCAD X Version 14.6.12 (7450)

- **Area Scan (101x281x1):** Interpolated grid: dx=1.000 mm, dy=1.000 mm  
Maximum value of SAR (interpolated) = 2.40 W/kg

- **Zoom Scan (6x6x12)/Cube 0:** Measurement grid: dx=5mm, dy=5mm, dz=2mm  
Reference Value = 19.91 V/m; Power Drift = -0.04 dB  
Peak SAR (extrapolated) = 4.13 W/kg  
**SAR(1 g) = 0.875 W/kg; SAR(10 g) = 0.338 W/kg**  
Maximum value of SAR (measured) = 2.19 W/kg

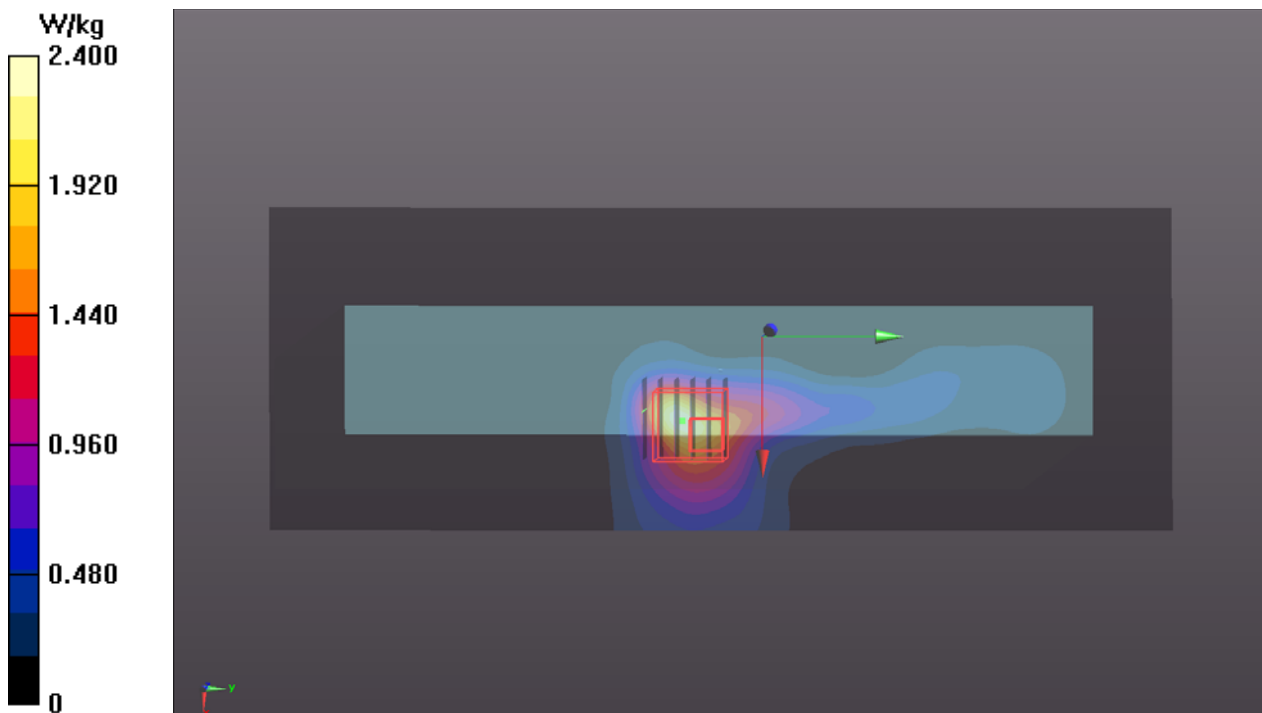

### P16 BT\_BDR\_Right Side\_0cm\_Ch78\_Sku2\_Ant1

#### DUT: 190506C08

Communication System: BT; Frequency: 2480 MHz; Duty Cycle: 1:1.3  
Medium: H19T27N1\_0626 Medium parameters used:  $f = 2480$  MHz;  $\sigma = 1.908$  S/m;  $\epsilon_r = 38.984$ ;  $\rho = 1000$  kg/m<sup>3</sup>  
Ambient Temperature : 23.6 °C ; Liquid Temperature : 23.2 °C

#### DASY5 Configuration:

- Probe: EX3DV4 - SN7375; ConvF(7.64, 7.64, 7.64); Calibrated: 2018/12/13
- Sensor-Surface: 1.4mm (Mechanical Surface Detection)
- Electronics: DAE4 Sn1277; Calibrated: 2019/01/24
- Phantom: ELI Phantom\_1204; Type: QDOVA;
- Measurement SW: DASY52, Version 52.10 (2); SEMCAD X Version 14.6.12 (7450)

- **Area Scan (91x241x1):** Interpolated grid: dx=1.200 mm, dy=1.200 mm  
Maximum value of SAR (interpolated) = 0.0700 W/kg

- **Zoom Scan (5x5x7)/Cube 0:** Measurement grid: dx=8mm, dy=8mm, dz=5mm  
Reference Value = 5.385 V/m; Power Drift = -0.12 dB  
Peak SAR (extrapolated) = 0.0720 W/kg  
**SAR(1 g) = 0.033 W/kg; SAR(10 g) = 0.015 W/kg**  
Maximum value of SAR (measured) = 0.0586 W/kg

- **Zoom Scan (5x5x7)/Cube 1:** Measurement grid: dx=8mm, dy=8mm, dz=5mm  
Reference Value = 5.385 V/m; Power Drift = -0.12 dB  
Peak SAR (extrapolated) = 0.0700 W/kg  
**SAR(1 g) = 0.029 W/kg; SAR(10 g) = 0.011 W/kg**  
Maximum value of SAR (measured) = 0.0524 W/kg

