

#01_WLAN2.4GHz_802.11b 1Mbps_Bottom Face_0mm_Ch6

Communication System: 802.11b; Frequency: 2437 MHz; Duty Cycle: 1:1.010

Medium: MSL_2450_180128 Medium parameters used: $f = 2437$ MHz; $\sigma = 2.005$ S/m; $\epsilon_r = 53.672$; $\rho = 1000$ kg/m³

Ambient Temperature : 23.5 °C ; Liquid Temperature : 22.5 °C

DASY5 Configuration:

- Probe: EX3DV4 - SN3578; ConvF(7.43, 7.43, 7.43); Calibrated: 2017/5/5;
- Sensor-Surface: 1.4mm (Mechanical Surface Detection)
- Electronics: DAE3 Sn393; Calibrated: 2017/8/10
- Phantom: ELI v5.0; Type: QDOVA002AA; Serial: 1131
- Measurement SW: DASY52, Version 52.8 (8); SEMCAD X Version 14.6.10 (7373)

Area Scan (101x61x1): Interpolated grid: dx=1.200 mm, dy=1.200 mm

Maximum value of SAR (interpolated) = 0.659 W/kg

Zoom Scan (7x7x7)/Cube 0: Measurement grid: dx=5mm, dy=5mm, dz=5mm

Reference Value = 22.041 V/m; Power Drift = -0.09 dB

Peak SAR (extrapolated) = 0.826 W/kg

SAR(1 g) = 0.402 W/kg; SAR(10 g) = 0.213 W/kg

Maximum value of SAR (measured) = 0.459 W/kg

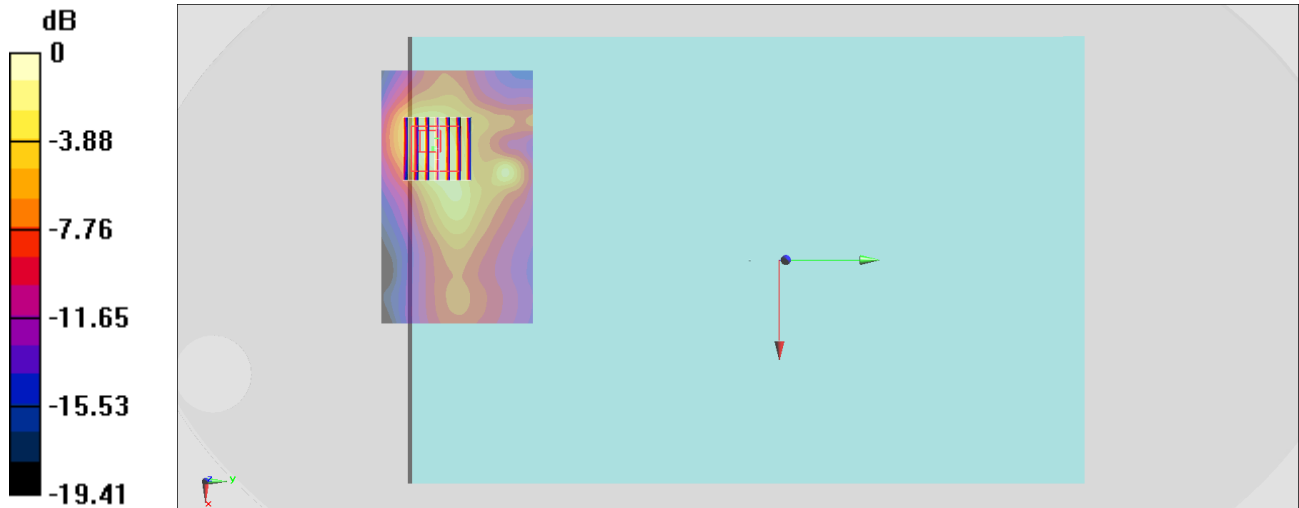

0 dB = 0.659 W/kg = -1.81 dBW/kg

#02_WLAN5GHz_802.11ac-VHT80 MCS0_Edge 3_0mm_Ch58

Communication System: 802.11ac; Frequency: 5290 MHz; Duty Cycle: 1:1.065

Medium: MSL_5G_180128 Medium parameters used: $f = 5290$ MHz; $\sigma = 5.433$ S/m; $\epsilon_r = 47.755$; $\rho = 1000$ kg/m³

Ambient Temperature : 23.5 °C ; Liquid Temperature : 22.5 °C

DASY5 Configuration:

- Probe: EX3DV4 - SN3578; ConvF(4.98, 4.98, 4.98); Calibrated: 2017/5/5;
- Sensor-Surface: 1.4mm (Mechanical Surface Detection)
- Electronics: DAE3 Sn393; Calibrated: 2017/8/10
- Phantom: ELI v5.0; Type: QDOVA002AA; Serial: 1131
- Measurement SW: DASY52, Version 52.8 (8); SEMCAD X Version 14.6.10 (7373)

Area Scan (61x121x1): Interpolated grid: dx=1.000 mm, dy=1.000 mm

Maximum value of SAR (interpolated) = 1.40 W/kg

Zoom Scan (9x9x7)/Cube 0: Measurement grid: dx=4mm, dy=4mm, dz=1.4mm

Reference Value = 11.51 V/m; Power Drift = -0.07 dB

Peak SAR (extrapolated) = 5.01 W/kg

SAR(1 g) = 0.581 W/kg; SAR(10 g) = 0.194 W/kg

Maximum value of SAR (measured) = 1.34 W/kg

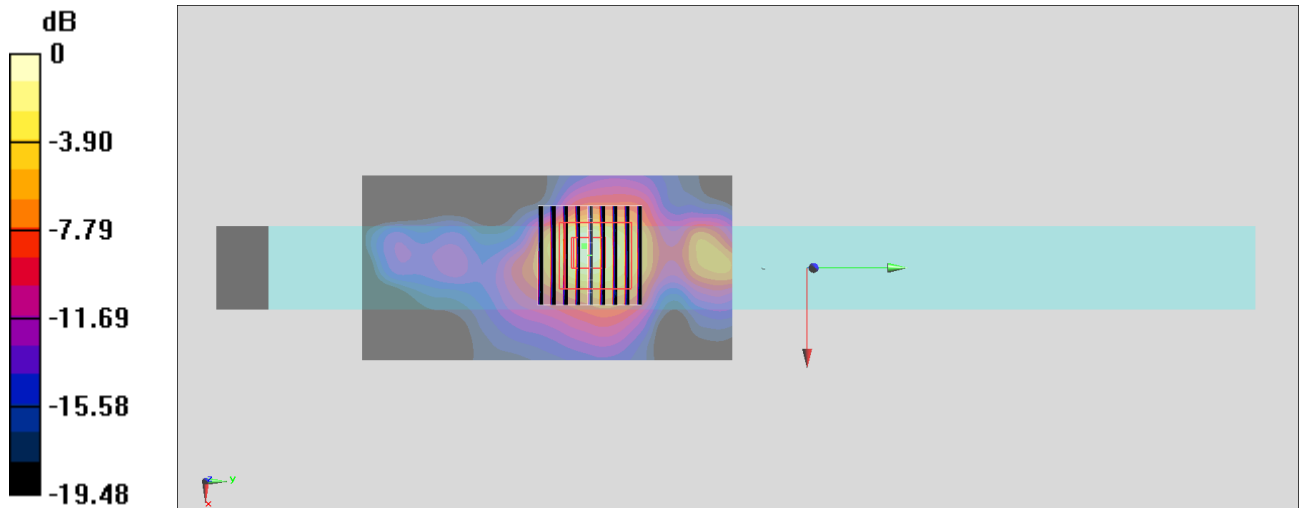

0 dB = 1.34 W/kg = 1.27 dBW/kg

#03_WLAN5GHz_802.11ac-VHT80 MCS0_Edge 4_0mm_Ch106

Communication System: 802.11ac; Frequency: 5530 MHz; Duty Cycle: 1:1.072

Medium: MSL_5G_180128 Medium parameters used: $f = 5530$ MHz; $\sigma = 5.744$ S/m; $\epsilon_r = 47.362$; $\rho = 1000$ kg/m³

Ambient Temperature : 23.5 °C ; Liquid Temperature : 22.5 °C

DASY5 Configuration:

- Probe: EX3DV4 - SN3578; ConvF(4.3, 4.3, 4.3); Calibrated: 2017/5/5;
- Sensor-Surface: 1.4mm (Mechanical Surface Detection)
- Electronics: DAE3 Sn393; Calibrated: 2017/8/10
- Phantom: ELI v5.0; Type: QDOVA002AA; Serial: 1131
- Measurement SW: DASY52, Version 52.8 (8); SEMCAD X Version 14.6.10 (7373)

Area Scan (61x91x1): Interpolated grid: dx=1.000 mm, dy=1.000 mm

Maximum value of SAR (interpolated) = 1.70 W/kg

Zoom Scan (7x7x7)/Cube 0: Measurement grid: dx=4mm, dy=4mm, dz=1.4mm

Reference Value = 15.15 V/m; Power Drift = -0.07 dB

Peak SAR (extrapolated) = 2.17 W/kg

SAR(1 g) = 0.572 W/kg; SAR(10 g) = 0.191 W/kg

Maximum value of SAR (measured) = 1.29 W/kg

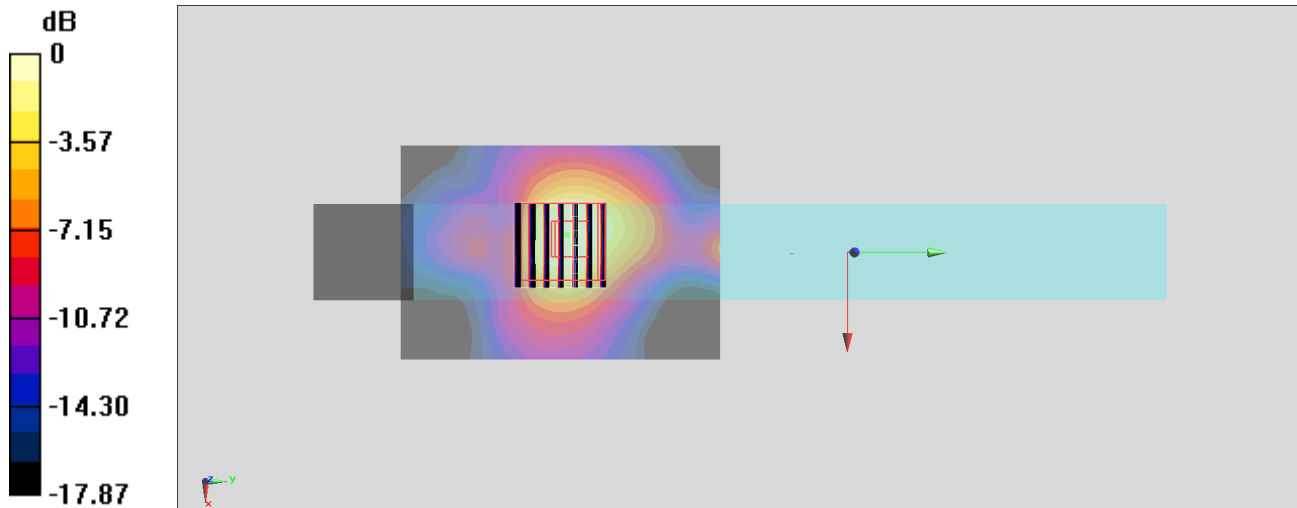

0 dB = 1.29 W/kg = 1.11 dBW/kg

#04_WLAN5GHz_802.11ac-VHT80 MCS0_Edge 4_0mm_Ch155

Communication System: 802.11ac; Frequency: 5775 MHz; Duty Cycle: 1:1.072

Medium: MSL_5G_180128 Medium parameters used: $f = 5775$ MHz; $\sigma = 6.082$ S/m; $\epsilon_r = 46.947$; $\rho = 1000$ kg/m³

Ambient Temperature : 23.5 °C ; Liquid Temperature : 22.5 °C

DASY5 Configuration:

- Probe: EX3DV4 - SN3578; ConvF(4.48, 4.48, 4.48); Calibrated: 2017/5/5;
- Sensor-Surface: 1.4mm (Mechanical Surface Detection)
- Electronics: DAE3 Sn393; Calibrated: 2017/8/10
- Phantom: ELI v5.0; Type: QDOVA002AA; Serial: 1131
- Measurement SW: DASY52, Version 52.8 (8); SEMCAD X Version 14.6.10 (7373)

Area Scan (61x91x1): Interpolated grid: dx=1.000 mm, dy=1.000 mm

Maximum value of SAR (interpolated) = 1.71 W/kg

Zoom Scan (7x7x7)/Cube 0: Measurement grid: dx=4mm, dy=4mm, dz=1.4mm

Reference Value = 14.91 V/m; Power Drift = -0.01 dB

Peak SAR (extrapolated) = 2.16 W/kg

SAR(1 g) = 0.515 W/kg; SAR(10 g) = 0.163 W/kg

Maximum value of SAR (measured) = 1.29 W/kg

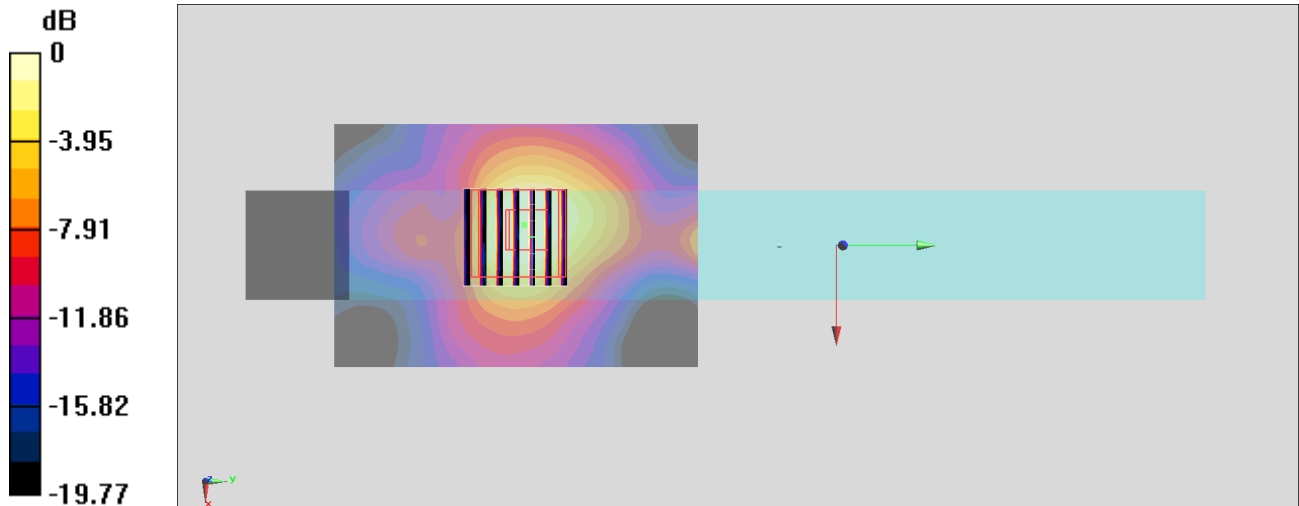

#05_Bluetooth_1Mbps_Edge 3_0mm_Ch78

Communication System: Bluetooth; Frequency: 2480 MHz; Duty Cycle: 1:1.297

Medium: MSL_2450_180128 Medium parameters used: $f = 2480$ MHz; $\sigma = 2.047$ S/m; $\epsilon_r = 53.511$; $\rho = 1000$ kg/m³

Ambient Temperature : 23.5 °C ; Liquid Temperature : 22.5 °C

DASY5 Configuration:

- Probe: EX3DV4 - SN3578; ConvF(7.43, 7.43, 7.43); Calibrated: 2017/5/5;
- Sensor-Surface: 1.4mm (Mechanical Surface Detection)
- Electronics: DAE3 Sn393; Calibrated: 2017/8/10
- Phantom: ELI v5.0; Type: QDOVA002AA; Serial: 1131
- Measurement SW: DASY52, Version 52.8 (8); SEMCAD X Version 14.6.10 (7373)

Area Scan (51x101x1): Interpolated grid: dx=1.200 mm, dy=1.200 mm

Maximum value of SAR (interpolated) = 0.104 W/kg

Zoom Scan (7x7x7)/Cube 0: Measurement grid: dx=5mm, dy=5mm, dz=5mm

Reference Value = 5.931 V/m; Power Drift = -0.11 dB

Peak SAR (extrapolated) = 0.132 W/kg

SAR(1 g) = 0.048 W/kg; SAR(10 g) = 0.026 W/kg

Maximum value of SAR (measured) = 0.106 W/kg

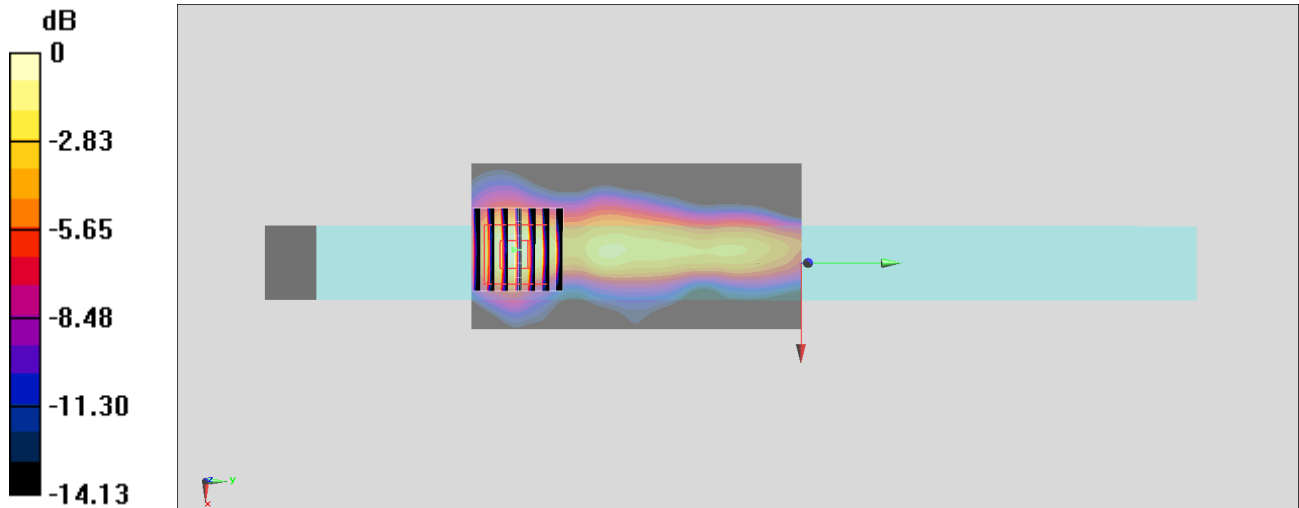

0 dB = 0.106 W/kg = -9.75 dBW/kg