

System Check_2450MHz_100625

DUT: Dipole 2450 MHz

Communication System: CW; Frequency: 2450 MHz; Duty Cycle: 1:1

Medium: MSL_2450_100625 Medium parameters used: $f = 2450$ MHz; $\sigma = 1.93$ mho/m; $\epsilon_r = 53.6$; $\rho = 1000$

kg/m³

Ambient Temperature : 22.4 ; Liquid Temperature : 21.4

DASY5 Configuration:

- Probe: ET3DV6 - SN1788; ConvF(4.19, 4.19, 4.19); Calibrated: 2009/9/23
- Sensor-Surface: 4mm (Mechanical Surface Detection)
- Electronics: DAE4 Sn778; Calibrated: 2009/9/18
- Phantom: ELI 4.0; Type: QDOVA001BA; Serial: 1029
- Measurement SW: DASY5, V5.0 Build 125; SEMCAD X Version 13.4 Build 125

Pin=100mW/Area Scan (91x91x1): Measurement grid: dx=10mm, dy=10mm

Maximum value of SAR (interpolated) = 5.84 mW/g

Pin=100mW/Zoom Scan (7x7x7)/Cube 0: Measurement grid: dx=5mm, dy=5mm, dz=5mm

Reference Value = 56.2 V/m; Power Drift = -0.00559 dB

Peak SAR (extrapolated) = 11.8 W/kg

SAR(1 g) = 5.06 mW/g; SAR(10 g) = 2.33 mW/g

Maximum value of SAR (measured) = 5.63 mW/g

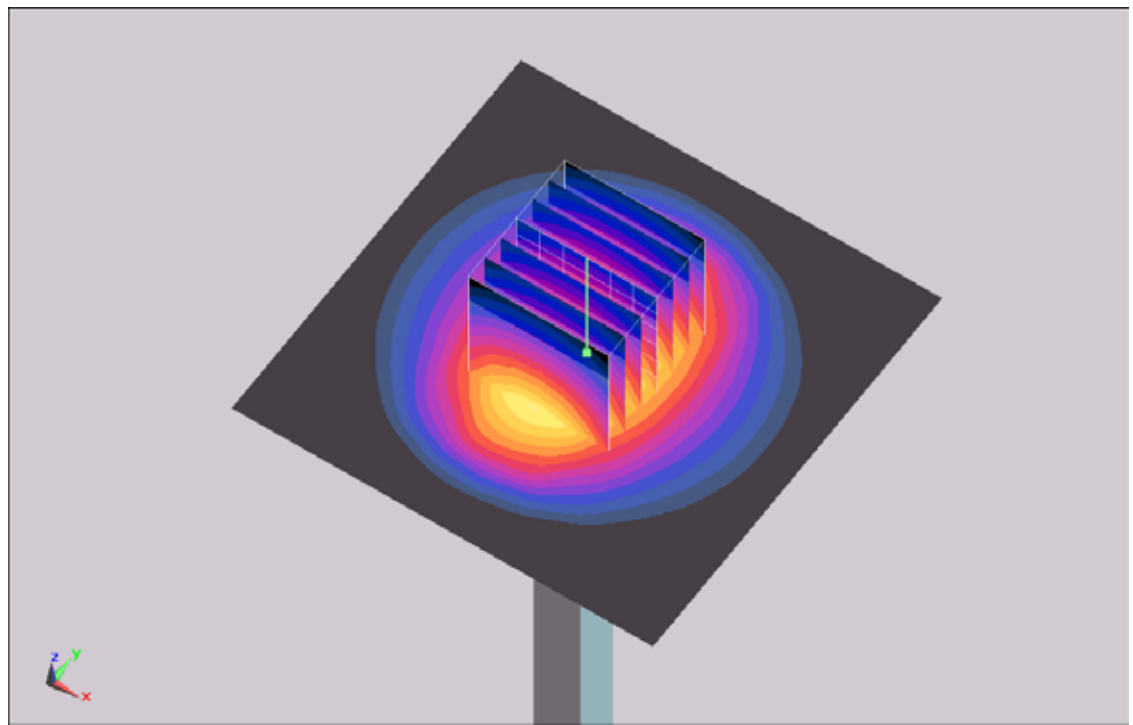
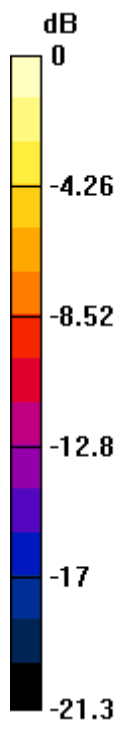

0 dB = 5.63mW/g

System Check_5200MHz_100625

DUT: Dipole 5GHz

Communication System: CW; Frequency: 5200 MHz; Duty Cycle: 1:1

Medium: MSL_5G_100525 Medium parameters used: $f = 5200$ MHz; $\sigma = 5.26$ mho/m; $\epsilon_r = 47.5$; $\rho = 1000$

kg/m³

Ambient Temperature : 22.4 ; Liquid Temperature : 21.2

DASY5 Configuration:

- Probe: EX3DV3 - SN3514; ConvF(4.27, 4.27, 4.27); Calibrated: 2010/1/26
- Sensor-Surface: 3mm (Mechanical Surface Detection)
- Electronics: DAE4 Sn778; Calibrated: 2009/9/18
- Phantom: ELI 4.0_Front; Type: QDOVA001BB; Serial: 1026
- Measurement SW: DASY5, V5.0 Build 125; SEMCAD X Version 13.4 Build 125

Pin=100mW/Area Scan (91x91x1): Measurement grid: dx=10mm, dy=10mm

Maximum value of SAR (interpolated) = 13.3 mW/g

Pin=100mW/Zoom Scan (8x8x8)/Cube 0: Measurement grid: dx=4.3mm, dy=4.3mm, dz=3mm

Reference Value = 51.5 V/m; Power Drift = -0.041 dB

Peak SAR (extrapolated) = 27.6 W/kg

SAR(1 g) = 8.04 mW/g; SAR(10 g) = 2.32 mW/g

Maximum value of SAR (measured) = 12 mW/g

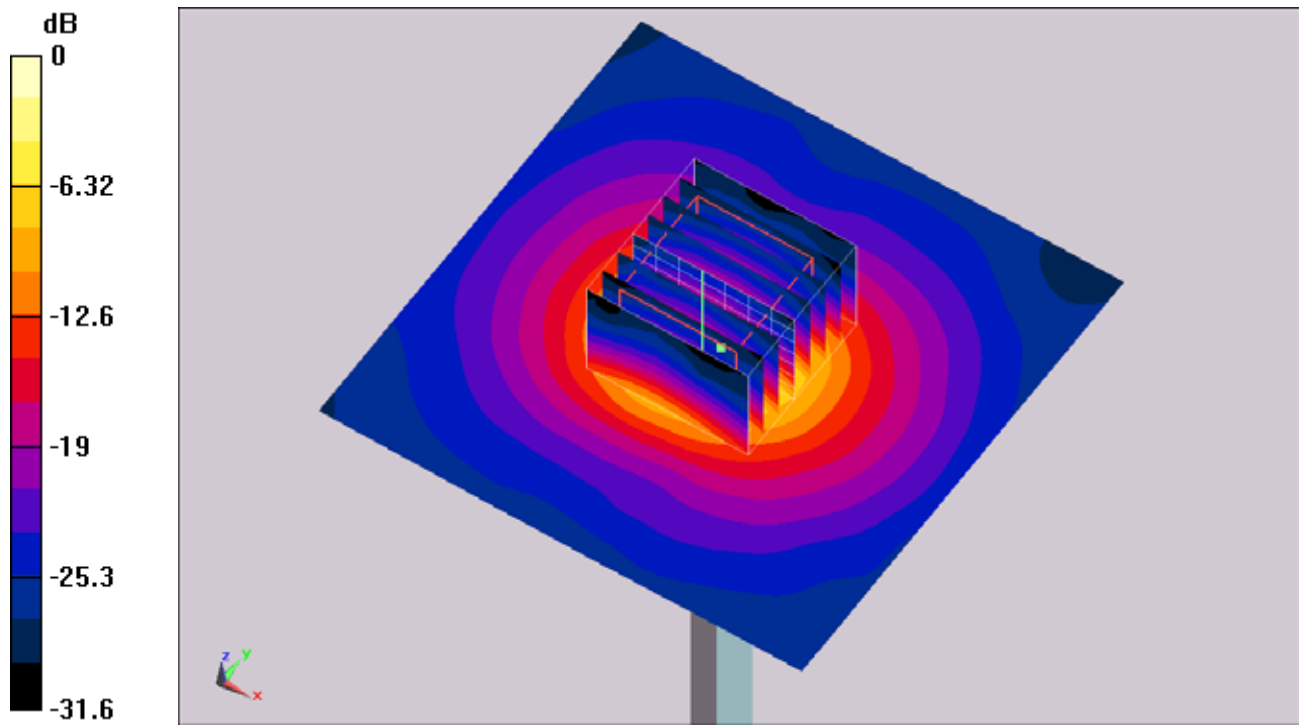

0 dB = 12mW/g

System Check_5200MHz_100626

DUT: Dipole 5GHz

Communication System: CW; Frequency: 5200 MHz; Duty Cycle: 1:1

Medium: MSL_5G_100626 Medium parameters used: $f = 5200$ MHz; $\sigma = 5.33$ mho/m; $\epsilon_r = 48.1$; $\rho = 1000$

kg/m³

Ambient Temperature : 22.4 ; Liquid Temperature : 21.2

DASY5 Configuration:

- Probe: EX3DV3 - SN3514; ConvF(4.27, 4.27, 4.27); Calibrated: 2010/1/26
- Sensor-Surface: 2.5mm (Mechanical Surface Detection)
- Electronics: DAE4 Sn778; Calibrated: 2009/9/18
- Phantom: ELI 4.0; Type: QDOVA001BA; Serial: 1029
- Measurement SW: DASY5, V5.0 Build 125; SEMCAD X Version 13.4 Build 125

Pin=100mW/Area Scan (91x91x1): Measurement grid: dx=10mm, dy=10mm

Maximum value of SAR (interpolated) = 12.6 mW/g

Pin=100mW/Zoom Scan (8x8x8)/Cube 0: Measurement grid: dx=4.3mm, dy=4.3mm, dz=3mm

Reference Value = 53 V/m; Power Drift = 0.098 dB

Peak SAR (extrapolated) = 26 W/kg

SAR(1 g) = 7.28 mW/g; SAR(10 g) = 2.04 mW/g

Maximum value of SAR (measured) = 12.3 mW/g

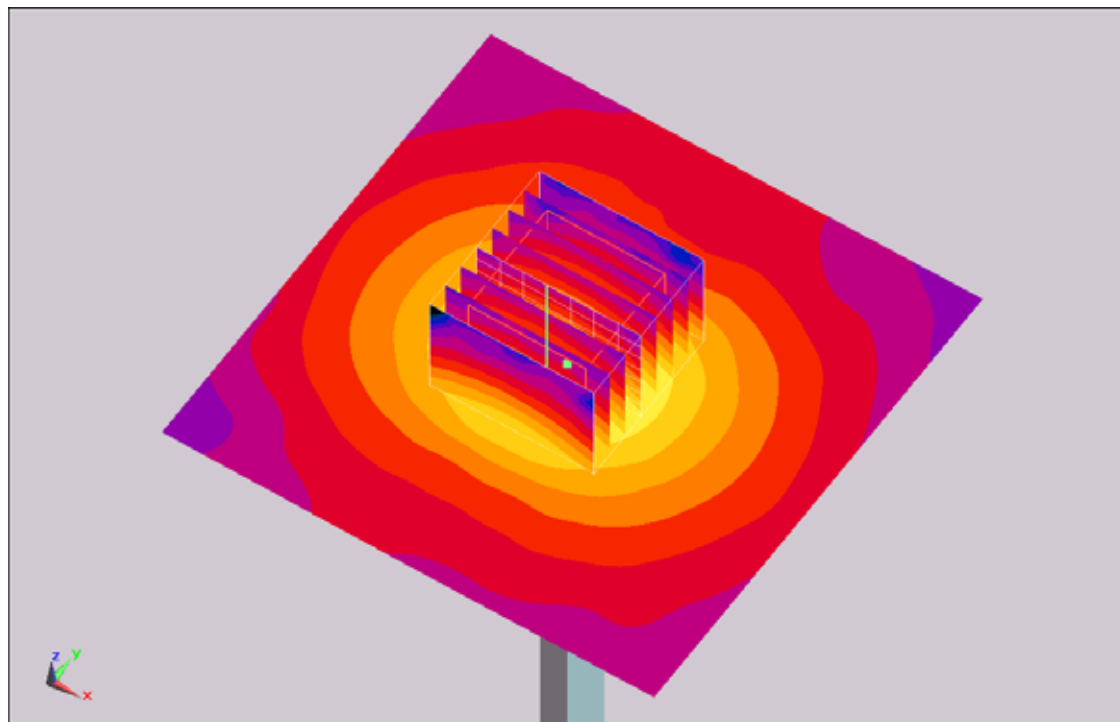
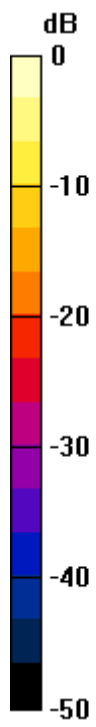

0 dB = 12.3mW/g

System Check_5500MHz_100626

DUT: Dipole 5GHz

Communication System: CW; Frequency: 5500 MHz; Duty Cycle: 1:1

Medium: MSL_5G_100626 Medium parameters used: $f = 5350$ MHz; $\sigma = 5.54$ mho/m; $\epsilon_r = 47.7$; $\rho = 1000$

kg/m³

Ambient Temperature : 22.3 ; Liquid Temperature : 21.3

DASY5 Configuration:

- Probe: EX3DV3 - SN3514; ConvF(3.86, 3.86, 3.86); Calibrated: 2010/1/26
- Sensor-Surface: 2.5mm (Mechanical Surface Detection)
- Electronics: DAE4 Sn778; Calibrated: 2009/9/18
- Phantom: ELI 4.0; Type: QDOVA001BA; Serial: 1029
- Measurement SW: DASY5, V5.0 Build 125; SEMCAD X Version 13.4 Build 125

Pin=100mW/Area Scan (91x91x1): Measurement grid: dx=10mm, dy=10mm

Maximum value of SAR (interpolated) = 13.6 mW/g

Pin=100mW/Zoom Scan (8x8x8)/Cube 0: Measurement grid: dx=4.3mm, dy=4.3mm, dz=3mm

Reference Value = 54.7 V/m; Power Drift = 0.065 dB

Peak SAR (extrapolated) = 28.9 W/kg

SAR(1 g) = 7.8 mW/g; SAR(10 g) = 2.19 mW/g

Maximum value of SAR (measured) = 13.1 mW/g

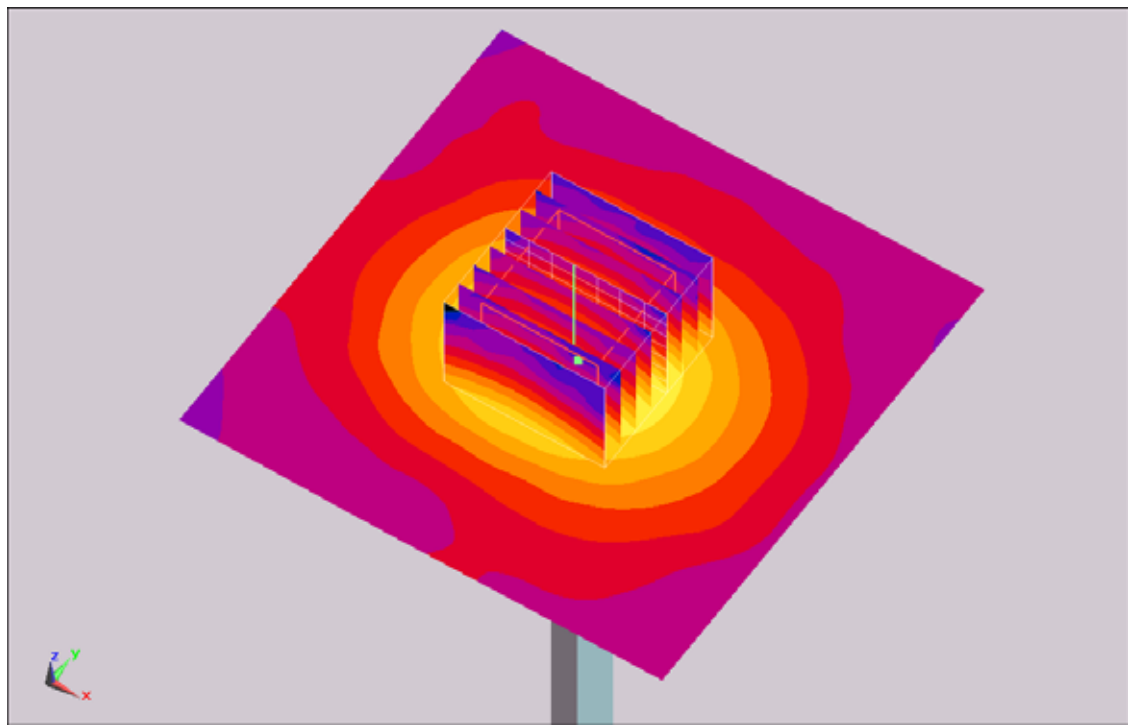

0 dB = 13.1mW/g

System Check_5800MHz_100627

DUT: Dipole 5GHz

Communication System: CW; Frequency: 5500 MHz; Duty Cycle: 1:1

Medium: MSL_5G_100525 Medium parameters used: $f = 5500$ MHz; $\sigma = 5.65$ mho/m; $\epsilon_r = 47$; $\rho = 1000$ kg/m³

Ambient Temperature : 22.5 ; Liquid Temperature : 21.2

DASY5 Configuration:

- Probe: EX3DV3 - SN3514; ConvF(3.86, 3.86, 3.86); Calibrated: 2010/1/26
- Sensor-Surface: 2.5mm (Mechanical Surface Detection)
- Electronics: DAE4 Sn778; Calibrated: 2009/9/18
- Phantom: ELI 4.0; Type: QDOVA001BA; Serial: 1029
- Measurement SW: DASY5, V5.0 Build 125; SEMCAD X Version 13.4 Build 125

Pin=100mW/Area Scan (91x91x1): Measurement grid: dx=10mm, dy=10mm

Maximum value of SAR (interpolated) = 14 mW/g

Pin=100mW/Zoom Scan (8x8x8)/Cube 0: Measurement grid: dx=4.3mm, dy=4.3mm, dz=3mm

Reference Value = 52.6 V/m; Power Drift = -0.027 dB

Peak SAR (extrapolated) = 27.7 W/kg

SAR(1 g) = 7.78 mW/g; SAR(10 g) = 2.21 mW/g

Maximum value of SAR (measured) = 13 mW/g

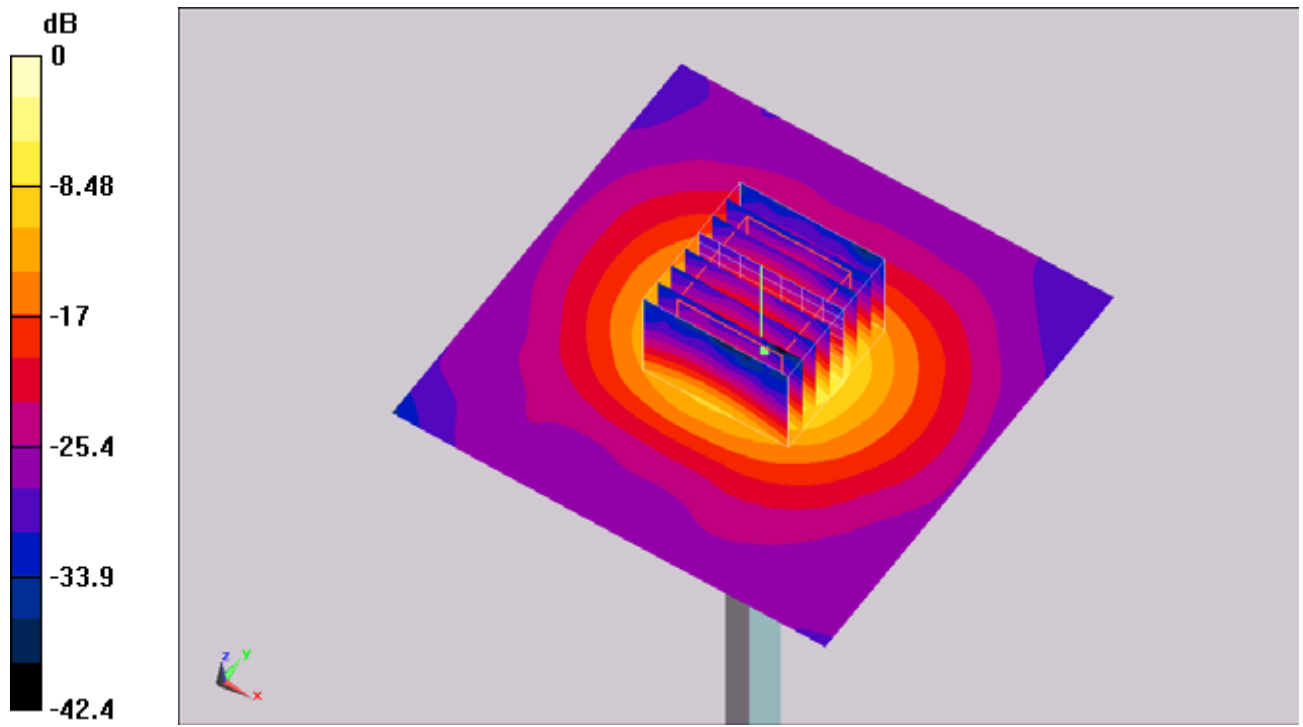

0 dB = 13mW/g