



RADIO TEST REPORT

FCC ID : QXO-AP5020
Equipment : Access Point
Brand Name : Extreme Networks
Model Name : AP5020
Applicant : Extreme Networks, Inc.
2121 RDU Center Drive Morrisville North Carolina
United States 27560
Manufacturer : Extreme Networks, Inc.
2121 RDU Center Drive Morrisville North Carolina
United States 27560
Standard : 47 CFR FCC Part 15.247

The product was received on Dec. 14, 2023, and testing was started from Jan. 11, 2024 and completed on Apr. 03, 2024. We, Sporton International Inc. Hsinchu Laboratory, would like to declare that the tested sample has been evaluated in accordance with the procedures given in ANSI C63.10-2013 and shown compliance with the applicable technical standards.

The test results in this report apply exclusively to the tested model / sample. Without written approval of Sporton International Inc. Hsinchu Laboratory, the test report shall not be reproduced except in full.



Approved by: Sam Chen

Sporton International Inc. Hsinchu Laboratory

No.8, Ln. 724, Bo'ai St., Zhubei City, Hsinchu County 302010, Taiwan (R.O.C.)



Table of Contents

History of this test report.....3

Summary of Test Result.....4

1 General Description5

1.1 Information.....5

1.2 Applicable Standards12

1.3 Testing Location Information12

1.4 Measurement Uncertainty12

2 Test Configuration of EUT13

2.1 Test Channel Mode13

2.2 The Worst Case Measurement Configuration14

2.3 EUT Operation during Test16

2.4 Accessories17

2.5 Support Equipment.....17

2.6 Test Setup Diagram18

3 Transmitter Test Result20

3.1 AC Power-line Conducted Emissions20

3.2 DTS Bandwidth.....22

3.3 Maximum Conducted Output Power23

3.4 Power Spectral Density26

3.5 Emissions in Non-restricted Frequency Bands28

3.6 Emissions in Restricted Frequency Bands.....29

4 Test Equipment and Calibration Data33

Appendix A. Test Results of AC Power-line Conducted Emissions

Appendix B. Test Results of DTS Bandwidth

Appendix C. Test Results of Maximum Conducted Output Power

Appendix D. Test Results of Power Spectral Density

Appendix E. Test Results of Emissions in Non-restricted Frequency Bands

Appendix F. Test Results of Emissions in Restricted Frequency Bands

Appendix G. Test Photos

Photographs of EUT v01



Summary of Test Result

Report Clause	Ref Std. Clause	Test Items	Result (PASS/FAIL)	Remark
1.1.2	15.203	Antenna Requirement	PASS	-
3.1	15.207	AC Power-line Conducted Emissions	PASS	-
3.2	15.247(a)	DTS Bandwidth	PASS	-
3.3	15.247(b)	Maximum Conducted Output Power	PASS	-
3.4	15.247(e)	Power Spectral Density	PASS	-
3.5	15.247(d)	Emissions in Non-restricted Frequency Bands	PASS	-
3.6	15.247(d)	Emissions in Restricted Frequency Bands	PASS	-

Conformity Assessment Condition:

1. The test results (PASS/FAIL) with all measurement uncertainty excluded are presented against the regulation limits or in accordance with the requirements stipulated by the applicant/manufacturer who shall bear all the risks of non-compliance that may potentially occur if measurement uncertainty is taken into account.
2. The measurement uncertainty please refer to each test result in the chapter "Measurement Uncertainty".

Disclaimer:

The product specifications of the EUT presented in the test report that may affect the test assessments are declared by the manufacturer who shall take full responsibility for the authenticity.

Reviewed by: Sam Chen

Report Producer: Lavender Zeng



1 General Description

1.1 Information

1.1.1 RF General Information

Frequency Range (MHz)	Bluetooth Mode	Ch. Frequency (MHz)	Channel Number
2400-2483.5	LE	2402-2480	0-39 [40]

Band	Mode	BWch (MHz)	Nant
2.4-2.4835GHz	BT-LE(1Mbps)	1	1
2.4-2.4835GHz	BT-LE(500Kb/s)	1	1
2.4-2.4835GHz	BT-LE(125Kb/s)	1	1
2.4-2.4835GHz	BT-LE(2Mbps)	2	1

Note:

- ♦ Bluetooth LE uses a GFSK modulation.
- ♦ BWch is the nominal channel bandwidth.



1.1.2 Antenna Information

Ant.	Operating Band	Brand	Model Name	Antenna Type	Connector	Gain (dBi)
1	WLAN 2.4GHz / 5GHz	Sercomm	6172001TJH.20	PIFA	I-PEX	Note 1
2	WLAN 2.4GHz / 5GHz	Sercomm	6172001TJH.21	PIFA	I-PEX	
3	WLAN 2.4GHz / 5GHz	Sercomm	6172001TJH.22	PIFA	I-PEX	
4	WLAN 2.4GHz / 5GHz	Sercomm	6172001TJH.23	PIFA	I-PEX	
5	WLAN 6GHz	Sercomm	6172001TJH.24	PIFA	I-PEX	
6	WLAN 6GHz	Sercomm	6172001TJH.25	PIFA	I-PEX	
7	WLAN 6GHz	Sercomm	6172001TJH.26	PIFA	I-PEX	
8	WLAN 6GHz	Sercomm	6172001TJH.27	PIFA	I-PEX	
9	WLAN 5GHz / 6GHz	Sercomm	6172001TJH.28	PIFA	I-PEX	
10	WLAN 5GHz / 6GHz	Sercomm	6172001TJH.29	PIFA	I-PEX	
11	Bluetooth / Zigbee	Sercomm	6172001TJH.30	PIFA	I-PEX	4.22
12	Bluetooth / Zigbee	Sercomm	6172001TJH.31	PIFA	I-PEX	4.12
13	Bluetooth / Zigbee	Sercomm	6172001TJH.32	PIFA	I-PEX	4.19
14	GPS	Sercomm	6172001TJH.33	PIFA	I-PEX	1.176GHz: 4.50 1.575GHz: 4.20

Ant.	Port							
	2.4GHz (Radio 1)	2.4GHz (Radio 3)	5GHz (Radio 1)	5GHz (Radio 2)	6GHz (Radio 1)	6GHz (Radio 3)	Bluetooth / Zigbee	GPS
1	1	-	-	1	-	-	-	-
2	2	-	-	2	-	-	-	-
3	3	1	-	3	-	-	-	-
4	4	2	-	4	-	-	-	-
5	-	-	-	-	-	1	-	-
6	-	-	-	-	-	2	-	-
7	-	-	-	-	-	3	-	-
8	-	-	-	-	-	4	-	-
9	-	-	1	-	1	-	-	-
10	-	-	2	-	2	-	-	-
11	-	-	-	-	-	-	1	-
12	-	-	-	-	-	-	2	-
13	-	-	-	-	-	-	-	-
14	-	-	-	-	-	-	-	1



Note 1:

Ant.	Antenna Gain (dBi)								
	2.4GHz	5GHz UNII 1	5GHz UNII 2A	5GHz UNII 2C	5GHz UNII 3	6GHz UNII 5	6GHz UNII 6	6GHz UNII 7	6GHz UNII 8
1	2.91	4.88	4.99	5.07	5.29	-	-	-	-
2	3.17	3.95	3.41	5.00	5.07	-	-	-	-
3	2.98	4.49	4.06	4.40	3.93	-	-	-	-
4	2.64	4.75	4.07	4.71	4.40	-	-	-	-
5	-	-	-	-	-	5.33	4.93	5.50	4.83
6	-	-	-	-	-	5.41	4.54	5.26	5.39
7	-	-	-	-	-	5.95	5.96	4.82	4.77
8	-	-	-	-	-	5.79	5.88	5.89	5.91
9	-	3.07	2.35	2.59	3.21	2.71	2.66	4.37	3.21
10	-	3.01	2.66	3.88	4.23	4.41	3.82	3.37	4.42
11	-	-	-	-	-	-	-	-	-
12	-	-	-	-	-	-	-	-	-
13	-	-	-	-	-	-	-	-	-
14	-	-	-	-	-	-	-	-	-

Ant.	Item	Directional gain (dBi)								
		2.4GHz	5GHz UNII 1	5GHz UNII 2A	5GHz UNII 2C	5GHz UNII 3	6GHz UNII 5	6GHz UNII 6	6GHz UNII 7	6GHz UNII 8
1~4 (4TX)	4T1S	6.00	8.49	7.89	8.04	7.52	-	-	-	-
	4T2S	3.17	5.49	4.99	5.07	5.29	-	-	-	-
	4T3S	3.17	4.88	4.99	5.07	5.29	-	-	-	-
1~2 (2TX)	2T1S	3.9	7.09	6.19	6.33	5.81	-	-	-	-
	2T2S	3.17	4.88	4.99	5.07	5.29	-	-	-	-
3~4 (2TX)	2T1S	3.05	5.48	5.79	6.26	5.87	-	-	-	-
	2T2S	2.98	4.75	4.07	4.71	4.40	-	-	-	-
5~8 (4TX)	4T1S	-	-	-	-	-	9.23	8.77	9.49	9.13
	4T2S	-	-	-	-	-	6.23	5.96	6.49	6.13
	4T3S	-	-	-	-	-	5.95	5.96	5.89	5.91
5~6 (2TX)	2T1S	-	-	-	-	-	7.38	6.63	8.00	7.03
	2T2S	-	-	-	-	-	5.41	4.93	5.50	5.39
9~10 (2TX)	2T1S	-	4.51	4.52	6.00	5.95	5.82	4.82	5.36	5.47
	2T2S	-	3.07	2.66	3.88	4.23	4.41	3.82	4.37	4.42

Note 2: The above information (excepting WLAN gain) was declared by manufacturer.



Note 3: The antenna gain (WLAN) and directional gain (WLAN) are measured which follow the procedure of KDB 662911 D03.

Note 4: The Bluetooth / Zigbee function of Antenna 13 is not enabled at this time.

Note 5: The DFS band is not enabled at this time.

Note 6:

<For Radio 1>

2.4GHz Function

IEEE 802.11b/g/n/VHT/ax/be

For 2TX/2RX:

Port 1 and Port 2 can be used as transmitting/receiving antenna.

Port 1 and Port 2 could transmit/receive simultaneously.

For 2TX/4RX:

Port 1, Port 2, Port 3 and Port 4 can be used as receiving antenna, but only Port 1 and Port 2 can be used as transmitting antenna.

Port 1, Port 2, Port 3 and Port 4 could receive simultaneously, but only Port 1 and Port 2 could transmit simultaneously.

For 4TX/4RX:

Port 1, Port 2, Port 3 and Port 4 can be used as transmitting/receiving antenna.

Port 1, Port 2, Port 3 and Port 4 could transmit/receive simultaneously.

5GHz Function

IEEE 802.11a/n/ac/ax/be

UNII 1~UNII 3:

For 2RX:

Port 1 and Port 2 can be used as receiving antenna.

Port 1 and Port 2 could receive simultaneously.

UNII1~UNII 2A:

For 2TX/2RX:

Port 1 and Port 2 can be used as transmitting/receiving antenna.

Port 1 and Port 2 could transmit/receive simultaneously.

6GHz Function

IEEE 802.11ax/be

For 2TX/2RX:

Port 1 and Port 2 can be used as transmitting/receiving antenna.

Port 1 and Port 2 could transmit/receive simultaneously.

<For Radio 2>

5GHz Function

IEEE 802.11a/n/ac/ax/be

For 2TX/4RX:

Port 1, Port 2, Port 3 and Port 4 can be used as receiving antenna, but only Port 1 and Port 2 can be used as transmitting antenna.

Port 1, Port 2, Port 3 and Port 4 could receive simultaneously, but only Port 1 and Port 2 could transmit simultaneously.

For 4TX/4RX:

Port 1, Port 2, Port 3 and Port 4 can be used as transmitting/receiving antenna.

Port 1, Port 2, Port 3 and Port 4 could transmit/receive simultaneously.



<For Radio 3>

2.4GHz Function

IEEE 802.11b/g/n/VHT/ax/be

For 1TX/2RX:

Port 1 and Port 2 can be used as receiving antenna, but only Port 1 can be used as transmitting antenna.
Port 1 and Port 2 could receive simultaneously.

For 2TX/2RX:

Port 1 and Port 2 can be used as transmitting/receiving antenna.
Port 1 and Port 2 could transmit/receive simultaneously.

6GHz Function

IEEE 802.11ax/be

For 2TX/4RX:

Port 1, Port 2, Port 3 and Port 4 can be used as receiving antenna, but only Port 1 and Port 2 can be used as transmitting antenna.

Port 1, Port 2, Port 3 and Port 4 could receive simultaneously, but only Port 1 and Port 2 could transmit simultaneously.

For 4TX/4RX:

Port 1, Port 2, Port 3 and Port 4 can be used as transmitting/receiving antenna.
Port 1, Port 2, Port 3 and Port 4 could transmit/receive simultaneously.

<For Radio 4>

Bluetooth/Zigbee Functions

For 1TX/1RX:

The EUT supports the antenna with TX and RX diversity functions.

Both Port 1 and Port 2 support transmit and receive functions, but only one of them will be used at one time.
The Port 1 generated the worst case, so it was selected to test and record in the report.



1.1.3 Mode Test Duty Cycle

Mode	DC	DCF (dB)	T (s)	VBW (Hz)_1/T
BT-LE(1Mbps)	0.63	2.01	378.437u	3k
BT-LE(2Mbps)	0.355	4.5	195.187u	10k

Note:

- ◆ DC is Duty Cycle.
- ◆ DCF is Duty Cycle Factor.

1.1.4 EUT Operational Condition

EUT Power Type	From Power Adapter / PoE		
Function	<input checked="" type="checkbox"/> Point-to-multipoint	<input type="checkbox"/> Point-to-point	
Test Software Version	DOS [ver 6.1.7601]		
Support Mode	<input checked="" type="checkbox"/> LE 1M PHY: 1 Mb/s		
	<input checked="" type="checkbox"/> LE Coded PHY (S=2): 500 Kb/s		
	<input checked="" type="checkbox"/> LE Coded PHY (S=8): 125 Kb/s		
	<input checked="" type="checkbox"/> LE 2M PHY: 2 Mb/s		

Note: The above information was declared by manufacturer.

1.1.5 Table for EUT Information

EUT	GPS Integrated Module
1	With
2	Without

Note 1: From the above EUTs, EUT 1 was selected as representative model for the test and its data was recorded in this report.

Note 2: The above information was declared by manufacturer.



1.1.6 Table for Radio Function

Radio	Support Band		
	2.4GHz	5GHz	6GHz
1	BW: 20MHz	2TX: UNII 1, 2RX: UNII 1&3 (scan) BW: 20/40/80MHz	UNII 5 or UNII 5~8 (scan) BW: 20/40/80/160MHz
2	-	UNII 3 or UNII 1&3 BW: 20/40/80MHz	-
3	BW: 20MHz	-	UNII 7~8 or UNII 5~8 BW: 20/40/80/160/320MHz
4	Bluetooth / Zigbee		
5	GPS		

Note: The above information was declared by manufacturer.

1.1.7 Table for EUT Operation Mode

Mode	Radio 1	Radio 2	Radio 3	Radio 4	Radio 5	Note
1	2.4GHz 4x4	5GHz (UNII 1&3) 4x4	6GHz (UNII 5~8) 4x4	Bluetooth or Zigbee	GPS	Tri Radio
2	2.4GHz 2x2 (TX) / 5GHz (2RX) / 6GHz (2RX)	5GHz (UNII 1&3) 4x4	6GHz (UNII 5~8) 4x4	Bluetooth or Zigbee	GPS	Full Band w/Scan
3	5GHz (UNII 1) 2x2	5GHz (UNII 3) 4x4	6GHz (UNII 5~8) 4x4	Bluetooth or Zigbee	GPS	Dual 5GHz w/6GHz
4	6GHz 2x2 (TX) / 2.4GHz (2RX) / 5GHz (2RX)	5GHz (UNII 1&3) 4x4	2.4GHz 2x2	Bluetooth or Zigbee	GPS	DBDC w/Scan
5	5GHz (UNII 1) 2x2	5GHz (UNII 3) 4x4	2.4GHz 2x2	Bluetooth or Zigbee	GPS	Dual 5GHz w/2.4GHz
6	6GHz (UNII 5) 2x2	5GHz (UNII 1&3) 4x4	6GHz (UNII 7~8) 4x4	Bluetooth or Zigbee	GPS	Dual 6GHz w/5GHz

Note: The above information was declared by manufacturer.



1.2 Applicable Standards

According to the specifications of the manufacturer, the EUT must comply with the requirements of the following standards:

- ♦ 47 CFR FCC Part 15.247
- ♦ ANSI C63.10-2013

The following reference test guidance is not within the scope of accreditation of TAF.

- ♦ FCC KDB 558074 D01 v05r02
- ♦ FCC KDB 414788 D01 v01r01

1.3 Testing Location Information

Testing Location Information	
Test Lab. : Sporton International Inc. Hsinchu Laboratory	
Hsinchu	ADD: No.8, Ln. 724, Bo'ai St., Zhubei City, Hsinchu County 302010, Taiwan (R.O.C.)
(TAF: 3787)	TEL: 886-3-656-9065 FAX: 886-3-656-9085
	Test site Designation No. TW3787 with FCC.
	Conformity Assessment Body Identifier (CABID) TW3787 with ISED.

Test Condition	Test Site No.	Test Engineer	Test Environment (°C / %)	Test Date
RF Conducted	TH01-CB	KJ Chang	21.7~23.2 / 65~69	Jan. 15, 2024 ~ Mar. 28, 2024
Radiated below 1GHz	03CH06-CB	George Fan	21.4-22.5 / 55-58	Jan. 11, 2024 ~ Apr. 02, 2024
Radiated above 1GHz	03CH01-CB	George Fan	21.2-22.3 / 56-59	Jan. 11, 2024 ~ Apr. 02, 2024
	03CH02-CB	George Fan	21.9-22.4 / 55-58	Jan. 11, 2024 ~ Apr. 02, 2024
AC Conduction	CO01-CB	Gray Lee	23~24 / 60~61	Apr. 03, 2024

1.4 Measurement Uncertainty

ISO/IEC 17025 requires that an estimate of the measurement uncertainties associated with the emissions test results be included in the report. The measurement uncertainties given below are based on a 95% confidence level (based on a coverage factor (k=2))

Test Items	Uncertainty	Remark
Conducted Emission (150kHz ~ 30MHz)	3.4 dB	Confidence levels of 95%
Radiated Emission (9kHz ~ 30MHz)	3.7 dB	Confidence levels of 95%
Radiated Emission (30MHz ~ 1,000MHz)	5.1 dB	Confidence levels of 95%
Radiated Emission (1GHz ~ 18GHz)	4.1 dB	Confidence levels of 95%
Radiated Emission (18GHz ~ 40GHz)	4.2 dB	Confidence levels of 95%
Conducted Emission	3.1 dB	Confidence levels of 95%
Output Power Measurement	0.8 dB	Confidence levels of 95%
Power Density Measurement	3.1 dB	Confidence levels of 95%
Bandwidth Measurement	2.2%	Confidence levels of 95%



2 Test Configuration of EUT

2.1 Test Channel Mode

Mode
BT-LE(1Mbps)
2402MHz
2440MHz
2480MHz
BT-LE(2Mbps)
2402MHz
2440MHz
2478MHz
2480MHz



2.2 The Worst Case Measurement Configuration

The Worst Case Mode for Following Conformance Tests	
Tests Item	AC power-line conducted emissions
Condition	AC power-line conducted measurement for line and neutral Test Voltage: 120Vac / 60Hz
Operating Mode	CTX
1	EUT 1 + Radio 1 (WLAN 2.4GHz) + Adapter
2	EUT 1 + Radio 1 (WLAN 2.4GHz) + PoE
Mode 2 has been evaluated to be the worst case among Mode 1~2, thus measurement for Mode 3 ~ 9 will follow this same test mode.	
3	EUT 1 + Radio 1 (WLAN 5GHz) + PoE
4	EUT 1 + Radio 1 (WLAN 6GHz) + PoE
5	EUT 1 + Radio 2 (WLAN 5GHz) + PoE
6	EUT 1 + Radio 3 (WLAN 2.4GHz) + PoE
7	EUT 1 + Radio 3 (WLAN 6GHz) + PoE
8	EUT 1 + Radio 4 (Bluetooth) + PoE
9	EUT 1 + Radio 4 (Zigbee) + PoE
For operating mode 8 is the worst case and it was record in this test report.	

The Worst Case Mode for Following Conformance Tests	
Tests Item	DTS Bandwidth Maximum Conducted Output Power Power Spectral Density Emissions in Non-restricted Frequency Bands
Test Condition	Conducted measurement at transmit chains
1	EUT 1 + Radio 4



The Worst Case Mode for Following Conformance Tests	
Tests Item	Emissions in Restricted Frequency Bands
Test Condition	Radiated measurement If EUT consist of multiple antenna assembly (multiple antenna are used in EUT regardless of spatial multiplexing MIMO configuration), the radiated test should be performed with highest antenna gain of each antenna type.
Operating Mode < 1GHz	CTX
	The EUT was performed at X axis, Y axis and Z axis position, and the worst case as below for Emissions in Restricted Frequency Bands above 1GHz. Thus, the measurement will follow this same test configuration.
1	EUT 1 in X axis + Radio 1 (WLAN 2.4GHz) + Adapter
2	EUT 1 in X axis + Radio 1 (WLAN 2.4GHz) + PoE
Mode 1 has been evaluated to be the worst case among Mode 1~2, thus measurement for Mode 3 ~ 9 will follow this same test mode.	
3	EUT 1 in Z axis + Radio 1 (WLAN 5GHz) + Adapter
4	EUT 1 in Z axis + Radio 1 (WLAN 6GHz) + Adapter
5	EUT 1 in Y axis + Radio 2 (WLAN 5GHz) + Adapter
6	EUT 1 in Y axis + Radio 3 (WLAN 2.4GHz) + Adapter
7	EUT 1 in Z axis + Radio 3 (WLAN 6GHz) + Adapter
8	EUT 1 in Z axis + Radio 4 (Bluetooth) + Adapter
9	EUT 1 in Z axis + Radio 4 (Zigbee) + Adapter
For operating mode 1 is the worst case and it was record in this test report.	
Operating Mode > 1GHz	CTX
1	EUT 1 in Z axis + Radio 4



The Worst Case Mode for Following Conformance Tests	
Tests Item	Simultaneous Transmission Analysis - Co-location RF Exposure Evaluation
Operating Mode	
1	Radio 1 (WLAN 2.4GHz) + Radio 2 (WLAN 5GHz/UNII 1&3) + Radio 3 (WLAN 6GHz/UNII 5~8) + Radio 4 (Zigbee)
2	Radio 1 (WLAN 2.4GHz) + Radio 2 (WLAN 5GHz/UNII 1&3) + Radio 3 (WLAN 6GHz/UNII 5~8) + Radio 4 (Bluetooth)
3	Radio 1 (WLAN 5GHz/UNII 1) + Radio 2 (WLAN 5GHz/UNII 3) + Radio 3 (WLAN 6GHz/UNII 5~8) + Radio 4 (Zigbee)
4	Radio 1 (WLAN 5GHz/UNII 1) + Radio 2 (WLAN 5GHz/UNII 3) + Radio 3 (WLAN 6GHz/UNII 5~8) + Radio 4 (Bluetooth)
5	Radio 1 (WLAN 6GHz/UNII 5~8) + Radio 2 (WLAN 5GHz/UNII 1&3) + Radio 3 (WLAN 2.4GHz) + Radio 4 (Zigbee)
6	Radio 1 (WLAN 6GHz/UNII 5~8) + Radio 2 (WLAN 5GHz/UNII 1&3) + Radio 3 (WLAN 2.4GHz) + Radio 4 (Bluetooth)
7	Radio 1 (WLAN 5GHz/UNII 1) + Radio 2 (WLAN 5GHz/UNII 3) + Radio 3 (WLAN 2.4GHz) + Radio 4 (Zigbee)
8	Radio 1 (WLAN 5GHz/UNII 1) + Radio 2 (WLAN 5GHz/UNII 3) + Radio 3 (WLAN 2.4GHz) + Radio 4 (Bluetooth)
9	Radio 1 (WLAN 6GHz/UNII 5) + Radio 2 (WLAN 5GHz/UNII 1&3) + Radio 3 (WLAN 6GHz/UNII 7~8) + Radio 4 (Zigbee)
10	Radio 1 (WLAN 6GHz/UNII 5) + Radio 2 (WLAN 5GHz/UNII 1&3) + Radio 3 (WLAN 6GHz/UNII 7~8) + Radio 4 (Bluetooth)
Refer to Sporton Test Report No.: FA410321 for Co-location RF Exposure Evaluation.	

Note: The PoE and adapter are for measurement only, would not be marketed.
PoE and adapter information as below:

Power	Brand Name	Model Name
PoE	PHIHONG	POE60U-1BT-X
Adapter	Powertron	PA1045-120HIB300

2.3 EUT Operation during Test

The EUT was programmed to be in continuously transmitting mode.



2.4 Accessories

Accessories
Mount bracket *1

2.5 Support Equipment

For AC Conduction:

Support Equipment				
No.	Equipment	Brand Name	Model Name	FCC ID
A	PoE	PHIHONG	POE60U-1BT-X	N/A
B	PC	ASUS	S300TA	TX2-RTL8821CE
C	Flash disk3.0	Transcend	JetFlash-703	N/A

For Radiated:

Support Equipment				
No.	Equipment	Brand Name	Model Name	FCC ID
A	Notebook	DELL	E4300	N/A
B	AC Adapter	Powertron	PA1045-120HIB300	N/A

For RF Conducted:

Support Equipment				
No.	Equipment	Brand Name	Model Name	FCC ID
A	Notebook	DELL	E4300	N/A
B	AC Adapter	Powertron	PA1045-120HIB300	N/A

2.6 Test Setup Diagram

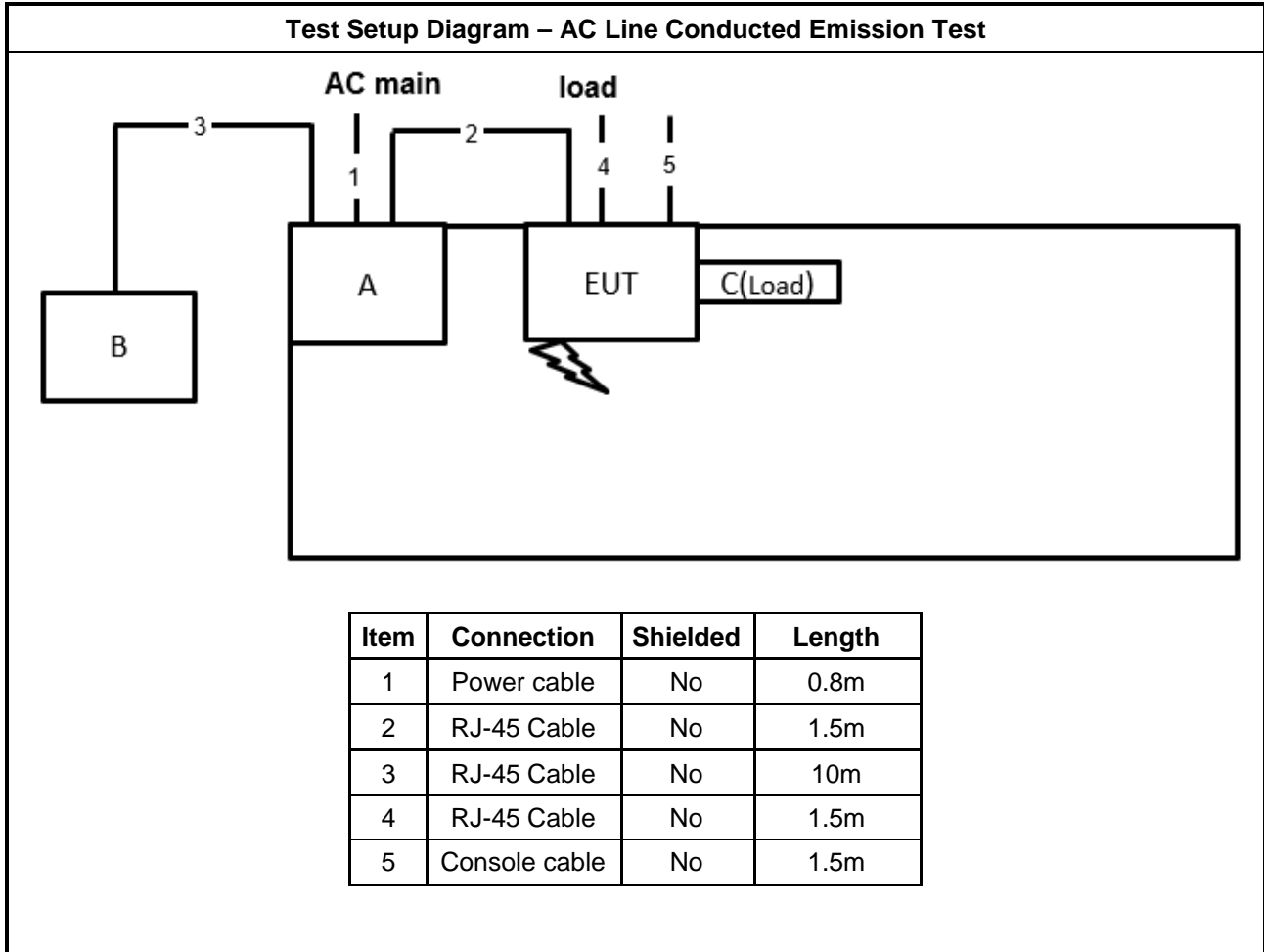



Test Setup Diagram - Radiated Test

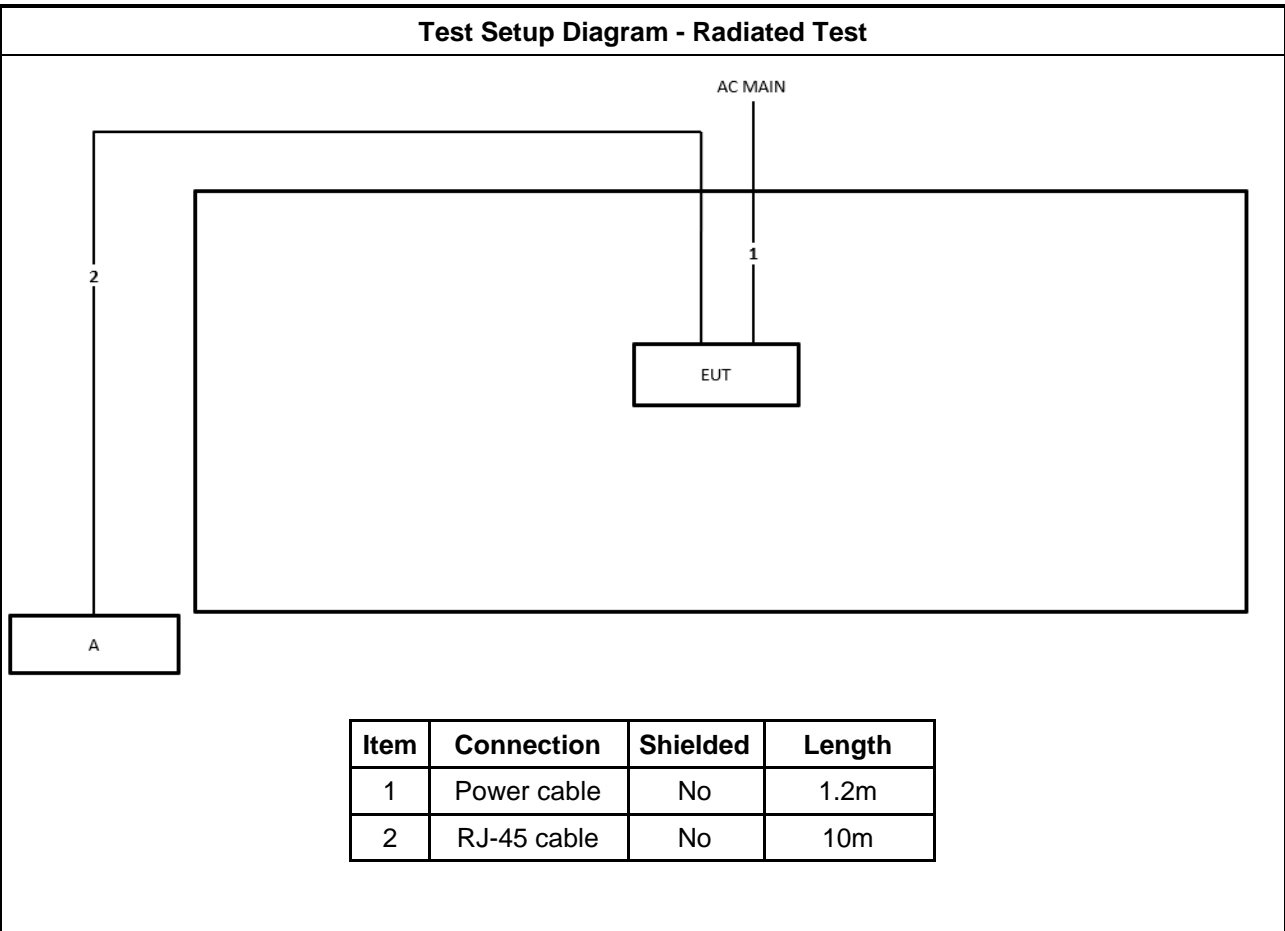

Item	Connection	Shielded	Length
1	Power cable	No	1.2m
2	RJ-45 cable	No	10m



3 Transmitter Test Result

3.1 AC Power-line Conducted Emissions

3.1.1 AC Power-line Conducted Emissions Limit

AC Power-line Conducted Emissions Limit		
Frequency Emission (MHz)	Quasi-Peak	Average
0.15-0.5	66 - 56 *	56 - 46 *
0.5-5	56	46
5-30	60	50

Note 1: * Decreases with the logarithm of the frequency.

3.1.2 Measuring Instruments

Refer a test equipment and calibration data table in this test report.

3.1.3 Test Procedures

Test Method
▪ Refer as ANSI C63.10-2013, clause 6.2 for AC power-line conducted emissions.

3.1.4 Test Setup

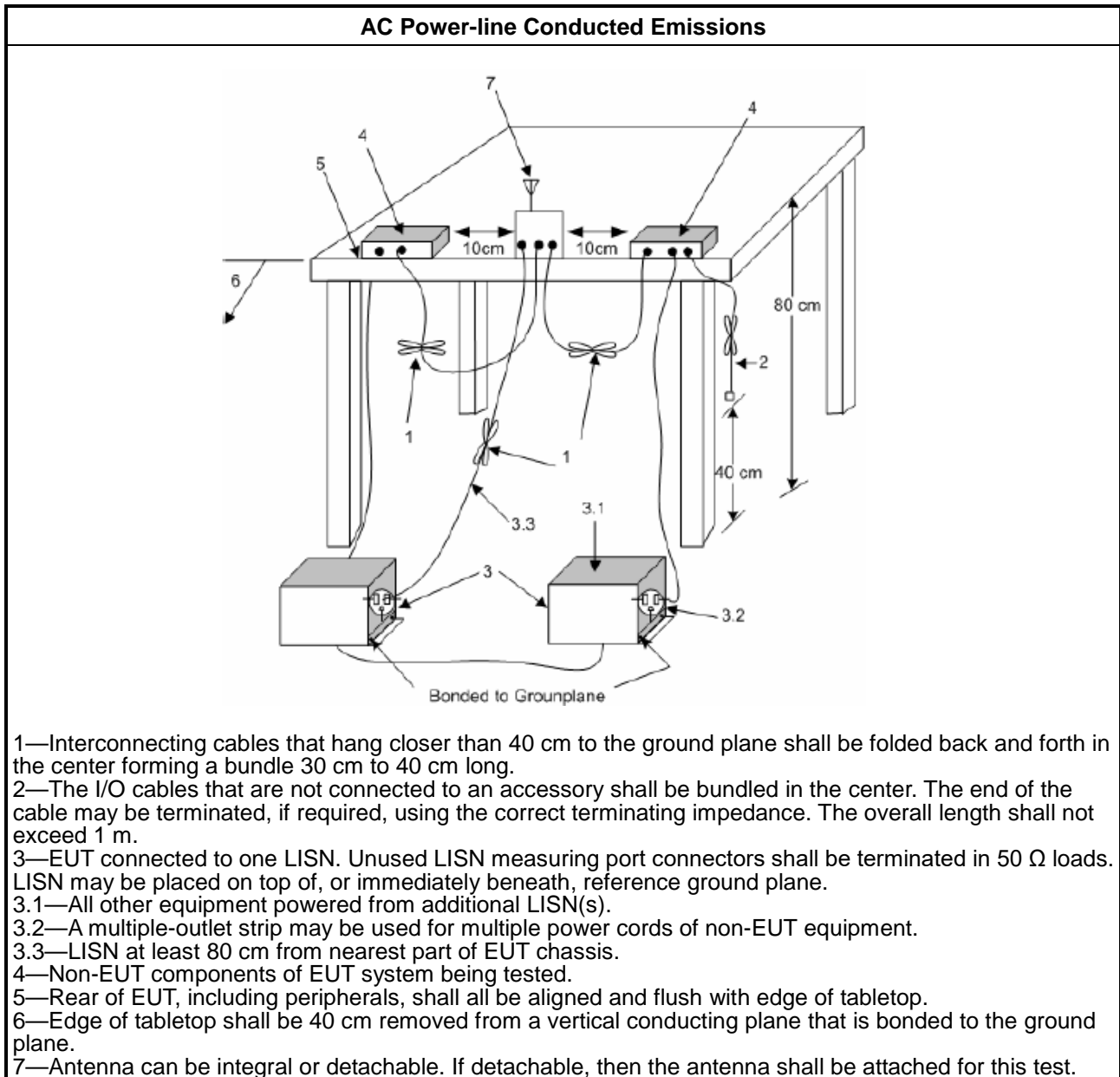

1.1.1. Measurement Results Calculation

The measured Level is calculated using:

- a. Corrected Reading: LISN Factor (LISN) + Attenuator (AT/AUX) + Cable Loss (CL) + Read Level (Raw) = Level
- b. Margin = -Limit + Level

3.1.5 Test Result of AC Power-line Conducted Emissions

Refer as Appendix A

3.2 DTS Bandwidth

3.2.1 6dB Bandwidth Limit

6dB Bandwidth Limit
Systems using digital modulation techniques:
<ul style="list-style-type: none"> ▪ 6 dB bandwidth \geq 500 kHz.

3.2.2 Measuring Instruments

Refer a test equipment and calibration data table in this test report.

3.2.3 Test Procedures

Test Method
<ul style="list-style-type: none"> ▪ For the emission bandwidth shall be measured using one of the options below:
<input checked="" type="checkbox"/> Refer as FCC KDB 558074, clause 8.2 & C63.10 clause 11.8.1 Option 1 for 6 dB bandwidth measurement.
<input type="checkbox"/> Refer as FCC KDB 558074, clause 8.2 & C63.10 clause 11.8.2 Option 2 for 6 dB bandwidth measurement.
<input type="checkbox"/> Refer as ANSI C63.10, clause 6.9.1 for occupied bandwidth testing.

3.2.4 Test Setup

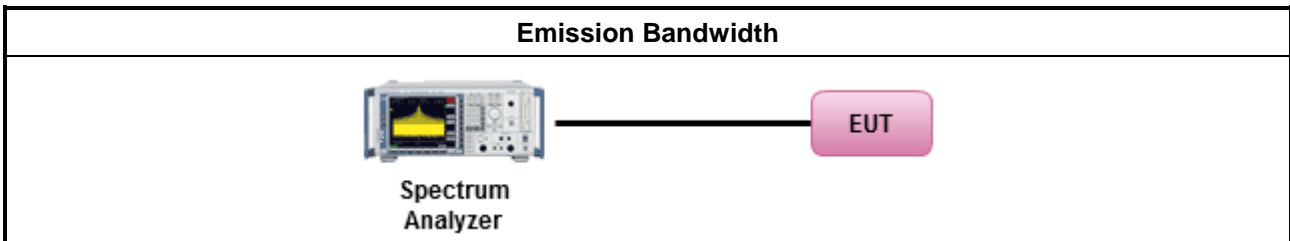

3.2.5 Test Result of Emission Bandwidth

Refer as Appendix B



3.3 Maximum Conducted Output Power

3.3.1 Maximum Conducted Output Power Limit

Maximum Conducted Output Power Limit	
	<ul style="list-style-type: none"> ▪ If $G_{TX} \leq 6$ dBi, then $P_{Out} \leq 30$ dBm (1 W)
	<ul style="list-style-type: none"> ▪ Point-to-multipoint systems (P2M): If $G_{TX} > 6$ dBi, then $P_{Out} = 30 - (G_{TX} - 6)$ dBm
	<ul style="list-style-type: none"> ▪ Point-to-point systems (P2P): If $G_{TX} > 6$ dBi, then $P_{Out} = 30 - (G_{TX} - 6)/3$ dBm
	<ul style="list-style-type: none"> ▪ Smart antenna system (SAS):
	<ul style="list-style-type: none"> - Single beam: If $G_{TX} > 6$ dBi, then $P_{Out} = 30 - (G_{TX} - 6)/3$ dBm
	<ul style="list-style-type: none"> - Overlap beam: If $G_{TX} > 6$ dBi, then $P_{Out} = 30 - (G_{TX} - 6)/3$ dBm
	<ul style="list-style-type: none"> - Aggregate power on all beams: If $G_{TX} > 6$ dBi, then $P_{Out} = 30 - (G_{TX} - 6)/3 + 8$ dB dBm
<p>P_{Out} = maximum peak conducted output power or maximum conducted output power in dBm, G_{TX} = the maximum transmitting antenna directional gain in dBi.</p>	

3.3.2 Measuring Instruments

Refer a test equipment and calibration data table in this test report.



3.3.3 Test Procedures

Test Method	
<ul style="list-style-type: none"> ▪ Maximum Peak Conducted Output Power 	
	<input type="checkbox"/> Refer as FCC KDB 558074, clause 8.3.1.1 & C63.10 clause 11.9.1.1 (RBW ≥ EBW method).
	<input type="checkbox"/> Refer as FCC KDB 558074, clause 8.3.1.3 & C63.10 clause 11.9.1.3 (peak power meter).
<ul style="list-style-type: none"> ▪ Maximum Conducted Output Power 	
[duty cycle ≥ 98% or external video / power trigger]	
	<input type="checkbox"/> Refer as FCC KDB 558074, clause 8.3.2.2 & C63.10 clause 11.9.2.2.2 Method AVGSA-1.
	<input type="checkbox"/> Refer as FCC KDB 558074, clause 8.3.2.2 & C63.10 clause 11.9.2.2.3 Method AVGSA-1A. (alternative)
duty cycle < 98% and average over on/off periods with duty factor	
	<input type="checkbox"/> Refer as FCC KDB 558074, clause 8.3.2.2 & C63.10 clause 11.9.2.2.4 Method AVGSA-2.
	<input type="checkbox"/> Refer as FCC KDB 558074, clause 8.3.2.2 & C63.10 clause 11.9.2.2.5 Method AVGSA-2A (alternative)
	<input type="checkbox"/> Refer as FCC KDB 558074, clause 8.3.2.2 & C63.10 clause 11.9.2.2.6 Method AVGSA-3
	<input type="checkbox"/> Refer as FCC KDB 558074, clause 8.3.2.2 & C63.10 clause 11.9.2.2.7 Method AVGSA-3A (alternative)
Measurement using a power meter (PM)	
	<input type="checkbox"/> Refer as FCC KDB 558074, clause 8.3.2.3 & C63.10 clause 11.9.2.3.1 Method AVGPM (using an RF average power meter).
	<input checked="" type="checkbox"/> Refer as FCC KDB 558074, clause 8.3.2.3 & C63.10 clause 11.9.2.3.2 Method AVGPM-G (using an gate RF average power meter).
<ul style="list-style-type: none"> ▪ For conducted measurement. 	
<ul style="list-style-type: none"> ▪ If the EUT supports multiple transmit chains using options given below: Refer as FCC KDB 662911, In-band power measurements. Using the measure-and-sum approach, measured all transmit ports individually. Sum the power (in linear power units e.g., mW) of all ports for each individual sample and save them. 	
<ul style="list-style-type: none"> ▪ If multiple transmit chains, EIRP calculation could be following as methods: $P_{total} = P_1 + P_2 + \dots + P_n$ (calculated in linear unit [mW] and transfer to log unit [dBm]) $EIRP_{total} = P_{total} + DG$ 	

3.3.4 Test Setup

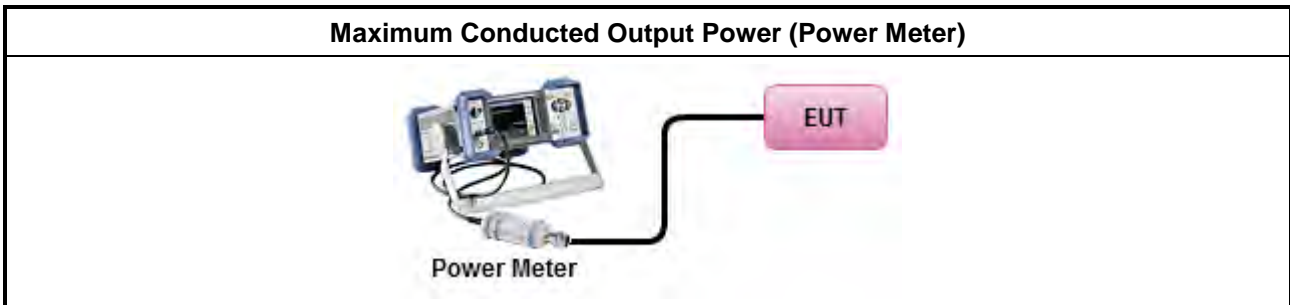

3.3.5 Test Result of Maximum Conducted Output Power

Refer as Appendix C



3.4 Power Spectral Density

3.4.1 Power Spectral Density Limit

Power Spectral Density Limit
<ul style="list-style-type: none"> Power Spectral Density (PSD) ≤ 8 dBm/3kHz

3.4.2 Measuring Instruments

Refer a test equipment and calibration data table in this test report.

3.4.3 Test Procedures

Test Method
<ul style="list-style-type: none"> Peak power spectral density procedures that the same method as used to determine the conducted output power. If maximum peak conducted output power was measured to demonstrate compliance to the output power limit, then the peak PSD procedure below (Method PKPSD) shall be used. If maximum conducted output power was measured to demonstrate compliance to the output power limit, then one of the average PSD procedures shall be used, as applicable based on the following criteria (the peak PSD procedure is also an acceptable option).
<input checked="" type="checkbox"/> Refer as FCC KDB 558074, clause 8.4 & C63.10 clause 11.10 Method Max. PSD. [duty cycle ≥ 98% or external video / power trigger]
<ul style="list-style-type: none"> For conducted measurement.
<ul style="list-style-type: none"> If The EUT supports multiple transmit chains using options given below: <ul style="list-style-type: none"> <input type="checkbox"/> Option 1: Measure and sum the spectra across the outputs. Refer as FCC KDB 662911, In-band power spectral density (PSD). Sample all transmit ports simultaneously using a spectrum analyzer for each transmit port. Where the trace bin-by-bin of each transmit port summing can be performed. (i.e., in the first spectral bin of output 1 is summed with that in the first spectral bin of output 2 and that from the first spectral bin of output 3, and so on up to the NTX output to obtain the value for the first frequency bin of the summed spectrum.). Add up the amplitude (power) values for the different transmit chains and use this as the new data trace. <input type="checkbox"/> Option 2: Measure and sum spectral maxima across the outputs. With this technique, spectra are measured at each output of the device at the required resolution bandwidth. The maximum value (peak) of each spectrum is determined. These maximum values are then summed mathematically in linear power units across the outputs. These operations shall be performed separately over frequency spans that have different out-of-band or spurious emission limits, <input type="checkbox"/> Option 3: Measure and add 10 log(N) dB, where N is the number of transmit chains. Refer as FCC KDB 662911, In-band power spectral density (PSD). Performed at each transmit chains and each transmit chains shall be compared with the limit have been reduced with 10 log(N). Or each transmit chains shall be add 10 log(N) to compared with the limit.

3.4.4 Test Setup

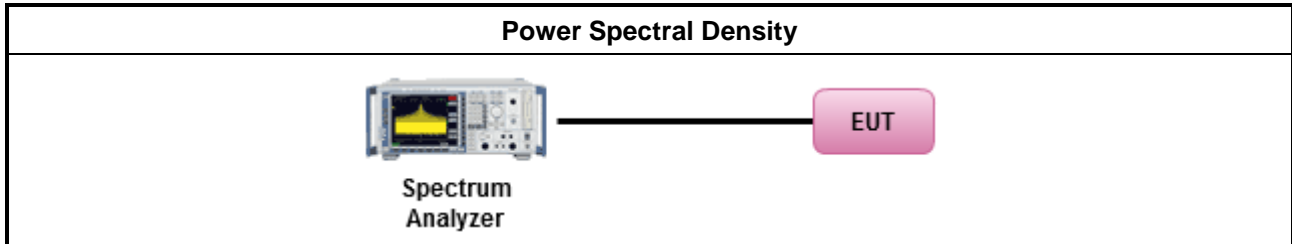

3.4.5 Test Result of Power Spectral Density

Refer as Appendix D

3.5 Emissions in Non-restricted Frequency Bands

3.5.1 Emissions in Non-restricted Frequency Bands Limit

Un-restricted Band Emissions Limit	
RF output power procedure	Limit (dBc)
Peak output power procedure	20
Average output power procedure	30

Note 1: If the peak output power procedure is used to measure the fundamental emission power to demonstrate compliance to requirements, then the peak conducted output power measured within any 100 kHz outside the authorized frequency band shall be attenuated by at least 20 dB relative to the maximum measured in-band peak PSD level.

Note 2: If the average output power procedure is used to measure the fundamental emission power to demonstrate compliance to requirements, then the power in any 100 kHz outside of the authorized frequency band shall be attenuated by at least 30 dB relative to the maximum measured in-band average PSD level.

3.5.2 Measuring Instruments

Refer a test equipment and calibration data table in this test report.

3.5.3 Test Procedures

Test Method
<ul style="list-style-type: none"> Refer as FCC KDB 558074, clause 8.5 for unwanted emissions into non-restricted bands.

3.5.4 Test Setup

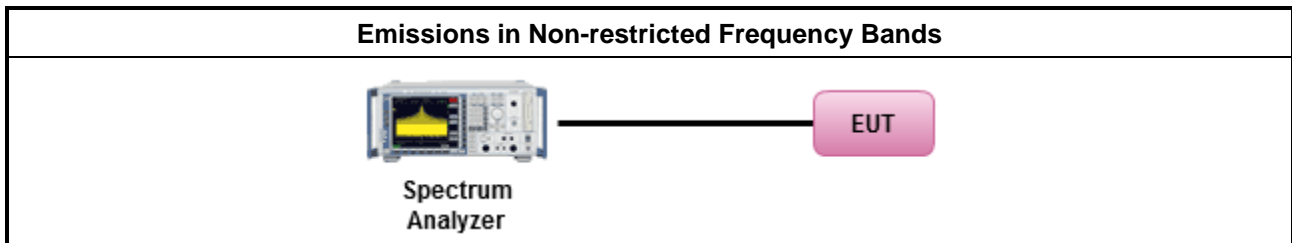

3.5.5 Test Result of Emissions in Non-restricted Frequency Bands

Refer as Appendix E



3.6 Emissions in Restricted Frequency Bands

3.6.1 Emissions in Restricted Frequency Bands Limit

Restricted Band Emissions Limit			
Frequency Range (MHz)	Field Strength (uV/m)	Field Strength (dBuV/m)	Measure Distance (m)
0.009~0.490	2400/F(kHz)	48.5 - 13.8	300
0.490~1.705	24000/F(kHz)	33.8 - 23	30
1.705~30.0	30	29	30
30~88	100	40	3
88~216	150	43.5	3
216~960	200	46	3
Above 960	500	54	3

Note 1: Test distance for frequencies at or above 30 MHz, measurements may be performed at a distance other than the limit distance provided they are not performed in the near field and the emissions to be measured can be detected by the measurement equipment. When performing measurements at a distance other than that specified, the results shall be extrapolated to the specified distance using an extrapolation factor of 20 dB/decade (inverse of linear distance for field-strength measurements, inverse of linear distance-squared for power-density measurements).

Note 2: Test distance for frequencies at below 30 MHz, measurements may be performed at a distance closer than the EUT limit distance; however, an attempt should be made to avoid making measurements in the near field. When performing measurements below 30 MHz at a closer distance than the limit distance, the results shall be extrapolated to the specified distance by either making measurements at a minimum of two or more distances on at least one radial to determine the proper extrapolation factor or by using the square of an inverse linear distance extrapolation factor (40 dB / decade). The test report shall specify the extrapolation method used to determine compliance of the EUT.

Note 3: Using the distance of 1m during the test for above 18 GHz, and the test value to correct for the distance factor at 3m.

3.6.2 Measuring Instruments

Refer a test equipment and calibration data table in this test report.



3.6.3 Test Procedures

Test Method	
<ul style="list-style-type: none"> ▪ The average emission levels shall be measured in [duty cycle ≥ 98 or duty factor]. 	
<ul style="list-style-type: none"> ▪ Refer as ANSI C63.10, clause 6.10.3 band-edge testing shall be performed at the lowest frequency channel and highest frequency channel within the allowed operating band. 	
<ul style="list-style-type: none"> ▪ For the transmitter unwanted emissions shall be measured using following options below: 	
	<ul style="list-style-type: none"> ▪ Refer as FCC KDB 558074, clause 8.6 for unwanted emissions into restricted bands.
	<input type="checkbox"/> Refer as FCC KDB 558074, clause 8.6 & C63.10 clause 11.12.2.5.1(trace averaging for duty cycle ≥98%).
	<input type="checkbox"/> Refer as FCC KDB 558074, clause 8.6 & C63.10 clause 11.12.2.5.2(trace averaging + duty factor).
	<input checked="" type="checkbox"/> Refer as FCC KDB 558074, clause 8.6 & C63.10 clause 11.12.2.5.3(Reduced VBW≥1/T).
	<input type="checkbox"/> Refer as ANSI C63.10, clause 11.12.2.5.3 (Reduced VBW). VBW ≥ 1/T, where T is pulse time.
	<input type="checkbox"/> Refer as ANSI C63.10, clause 7.5 average value of pulsed emissions.
	<input checked="" type="checkbox"/> Refer as FCC KDB 558074, clause 8.6 & C63.10 clause 11.12.2.4 measurement procedure peak limit.
<ul style="list-style-type: none"> ▪ For the transmitter band-edge emissions shall be measured using following options below: 	
	<ul style="list-style-type: none"> ▪ Refer as FCC KDB 558074 clause 8.7 & c63.10 clause 11.13.1, When the performing peak or average radiated measurements, emissions within 2 MHz of the authorized band edge may be measured using the marker-delta method described below.
	<ul style="list-style-type: none"> ▪ Refer as FCC KDB 558074, clause 8.7 (ANSI C63.10, clause 6.10.6) for marker-delta method for band-edge measurements.
	<ul style="list-style-type: none"> ▪ Refer as FCC KDB 558074, clause 8.7 for narrower resolution bandwidth (100kHz) using the band power and summing the spectral levels (i.e., 1 MHz).
	<ul style="list-style-type: none"> ▪ For conducted unwanted emissions into restricted bands (absolute emission limits). Devices with multiple transmit chains using options given below: (1) Measure and sum the spectra across the outputs or (2) Measure and add 10 log(N) dB
	<ul style="list-style-type: none"> ▪ For FCC KDB 662911 The methodology described here may overestimate array gain, thereby resulting in apparent failures to satisfy the out-of-band limits even if the device is actually compliant. In such cases, compliance may be demonstrated by performing radiated tests around the frequencies at which the apparent failures occurred.

3.6.4 Test Setup

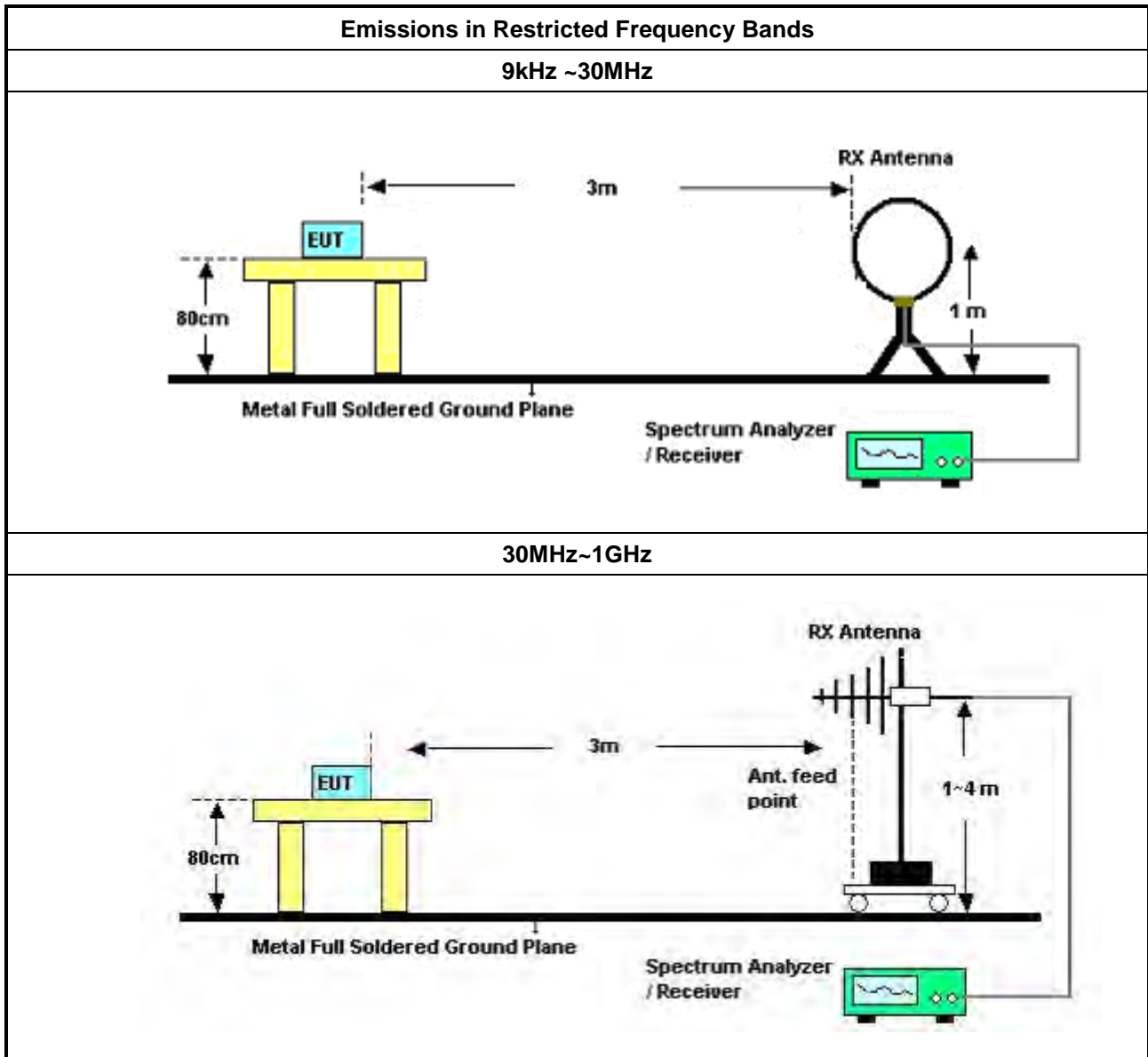

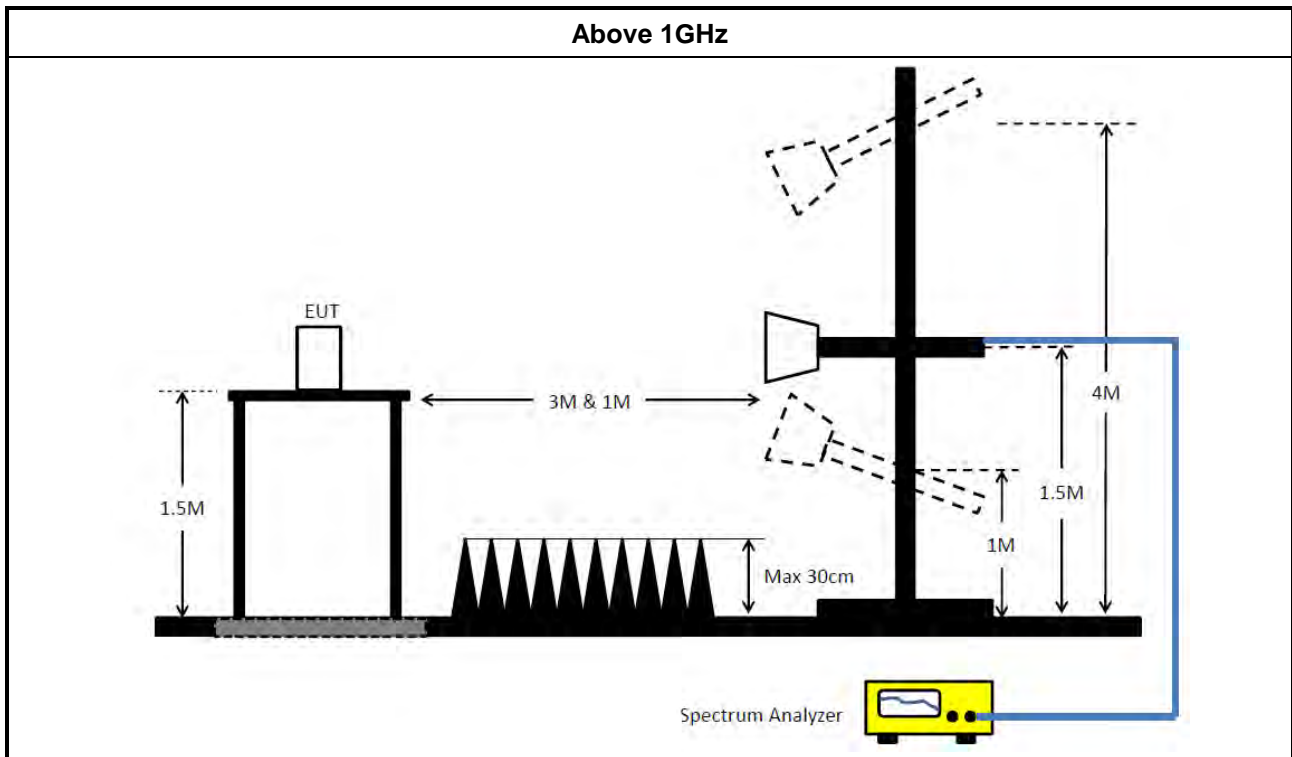

3.6.5 Measurement Results Calculation

The measured Level is calculated using:

Corrected Reading: Antenna factor (AF) + Cable loss (CL) + Read level (Raw) - Preamp factor (PA)(if applicable) = Level.

3.6.6 Emissions in Restricted Frequency Bands (Below 30MHz)

There is a comparison data of both open-field test site and alternative test site - semi-Anechoic chamber according to KDB414788 Radiated Test Site, and the result came out very similar.

All amplitude of spurious emissions that are attenuated by more than 20 dB below the permissible value has no need to be reported.

The radiated emissions were investigated from 9 kHz or the lowest frequency generated within the device, up to the 10th harmonic or 40 GHz, whichever is appropriate.

3.6.7 Test Result of Emissions in Restricted Frequency Bands

Refer as Appendix F



4 Test Equipment and Calibration Data

Instrument	Brand	Model No.	Serial No.	Characteristics	Calibration Date	Calibration Due Date	Remark
EMI Receiver	Agilent	N9038A	My52260123	9kHz ~ 8.4GHz	Mar. 01, 2024	Feb. 28, 2025	Conduction (CO01-CB)
LISN	F.C.C.	FCC-LISN-50-16-2	04083	150kHz ~ 100MHz	Feb. 19, 2024	Feb. 18, 2025	Conduction (CO01-CB)
LISN	Schwarzbeck	NSLK 8127	8127647	9kHz ~ 30MHz	Apr. 27, 2023	Apr. 26, 2024	Conduction (CO01-CB)
Pulse Limiter	Rohde&Schwarz	ESH3-Z2	100430	9kHz ~ 30MHz	Feb. 08, 2024	Feb. 07, 2025	Conduction (CO01-CB)
COND Cable	Woken	Cable	Low cable-CO01	9kHz ~ 30MHz	Oct. 17, 2023	Oct. 16, 2024	Conduction (CO01-CB)
Software	SPORTON	SENSE	V5.10	-	N.C.R.	N.C.R.	Conduction (CO01-CB)
3m Semi Anechoic Chamber VSWR	TDK	SAC-3M	03CH01-CB	1GHz ~18GHz 3m	May 05, 2023	May 04, 2024	Radiation (03CH01-CB)
Horn Antenna	SCHWARZBECK	BBHA 9120 D	BBHA 9120D-01816	1GHz~18GHz	Dec. 20, 2023	Dec. 19, 2024	Radiation (03CH01-CB)
Horn Antenna	Schwarzbeck	BBHA 9170	BBHA9170252	15GHz ~ 40GHz	Sep. 04, 2023	Sep. 03, 2024	Radiation (03CH01-CB)
Pre-Amplifier	Agilent	8449B	3008A02121	1GHz ~ 26.5GHz	May 18, 2023	May 17, 2024	Radiation (03CH01-CB)
Pre-Amplifier	SGH	SGH184	20221107-3	18GHz ~ 40GHz	Nov. 24, 2023	Nov. 23, 2024	Radiation (03CH01-CB)
Signal Analyzer	R&S	FSV3044	101437	10kHz ~ 44GHz	Nov. 28, 2023	Nov. 27, 2024	Radiation (03CH01-CB)
RF Cable-high	Woken	RG402	High Cable-16	1 GHz ~ 18 GHz	Nov. 06, 2023	Nov. 05, 2024	Radiation (03CH01-CB)
RF Cable-high	Woken	RG402	High Cable-16+17	1 GHz ~ 18 GHz	Nov. 06, 2023	Nov. 05, 2024	Radiation (03CH01-CB)
High Cable	Woken	WCA0929M	40G#5+6	1GHz ~ 40 GHz	Jan. 11, 2024	Jan. 10, 2025	Radiation (03CH01-CB)
Test Software	SPORTON	SENSE	V5.10	-	N.C.R.	N.C.R.	Radiation (03CH01-CB)
3m Semi Anechoic Chamber VSWR	RIKEN	SAC-3M	03CH02-CB	1GHz ~18GHz	Mar. 25, 2023	Mar. 24, 2024	Radiation (03CH02-CB)
3m Semi Anechoic Chamber VSWR	RIKEN	SAC-3M	03CH02-CB	1GHz ~18GHz	Mar. 24, 2024	Mar. 23, 2025	Radiation (03CH02-CB)
Horn Antenna	EMCO	3115	9610-4976	1GHz ~ 18GHz	Apr. 18, 2023	Apr. 17, 2024	Radiation (03CH02-CB)
Horn Antenna	Schwarzbeck	BBHA 9170	BBHA9170252	15GHz ~ 40GHz	Sep. 04, 2023	Sep. 03, 2024	Radiation (03CH02-CB)
Pre-Amplifier	Agilent	83017A	MY39501305	1GHz ~ 26.5GHz	Jun. 30, 2023	Jun. 29, 2024	Radiation (03CH02-CB)



Instrument	Brand	Model No.	Serial No.	Characteristics	Calibration Date	Calibration Due Date	Remark
Pre-Amplifier	SGH	SGH184	20221107-3	18GHz ~ 40GHz	Nov. 24, 2023	Nov. 23, 2024	Radiation (03CH02-CB)
Signal Analyzer	R&S	FSV40	101903	9kHz ~ 40GHz	May 29, 2023	May 28, 2024	Radiation (03CH02-CB)
RF Cable-high	Woken	RG402	High Cable-18	1GHz ~ 18GHz	Oct. 02, 2023	Oct. 01, 2024	Radiation (03CH02-CB)
RF Cable-high	Woken	RG402	High Cable-18+19	1GHz ~ 18GHz	Oct. 02, 2023	Oct. 01, 2024	Radiation (03CH02-CB)
High Cable	Woken	WCA0929M	40G#5+6	1GHz ~ 40 GHz	Jan. 11, 2024	Jan. 10, 2025	Radiation (03CH02-CB)
Test Software	SPORTON	SENSE	V5.10	-	N.C.R.	N.C.R.	Radiation (03CH02-CB)
Loop Antenna	Teseq	HLA 6121	65417	9kHz - 30 MHz	Oct. 13, 2023	Oct. 12, 2024	Radiation (03CH06-CB)
3m Semi Anechoic Chamber NSA	TDK	SAC-3M	03CH06-CB	30 MHz ~ 1 GHz	Aug. 03, 2023	Aug. 02, 2024	Radiation (03CH06-CB)
Bilog Antenna with 6 dB attenuator	TESEQ & EMCI	CBL6112D & N-6-06	37878 & AT-N0606	20MHz ~ 2GHz	Jul. 30, 2023	Jul. 29, 2024	Radiation (03CH06-CB)
Pre-Amplifier	Agilent	310N	187290	0.1MHz ~ 1GHz	Nov. 03, 2023	Nov. 02, 2024	Radiation (03CH06-CB)
Signal Analyzer	R&S	FSV40	101904	9kHz ~ 40GHz	Apr. 21, 2023	Apr. 20, 2024	Radiation (03CH06-CB)
EMI Test Receiver	R&S	ESCS	826547/017	9kHz ~ 2.75GHz	Jun. 13, 2023	Jun. 12, 2024	Radiation (03CH06-CB)
RF Cable-low	Woken	RG402	Low Cable-24+68	30MHz~1GHz	Oct. 02, 2023	Oct. 01, 2024	Radiation (03CH06-CB)
Test Software	SPORTON	SENSE	V5.10	-	N.C.R.	N.C.R.	Radiation (03CH06-CB)
Spectrum analyzer	R&S	FSV40	100979	9kHz~40GHz	May 29, 2023	May 28, 2024	Conducted (TH01-CB)
Band Rejector	MTJ	6G Band Rejector	6G-BRJ-01	1 ~ 18GHz	Oct. 03, 2023	Oct. 02, 2024	Conducted (TH01-CB)
Band Rejector	MTJ	6G Band Rejector	6G-BRJ-02	1~ 18GHz	Oct. 03, 2023	Oct. 02, 2024	Conducted (TH01-CB)
Switch	SPTCB	SP-SWI	SWI-01	1~26.5 GHz	Oct. 03, 2023	Oct. 02, 2024	Conducted (TH01-CB)
RF Cable-high	Woken	RG402	High Cable-06	1 GHz – 18 GHz	Oct. 02, 2023	Oct. 01, 2024	Conducted (TH01-CB)
RF Cable-high	Woken	RG402	High Cable-07	1 GHz – 18 GHz	Oct. 02, 2023	Oct. 01, 2024	Conducted (TH01-CB)
RF Cable-high	Woken	RG402	High Cable-08	1 GHz – 18 GHz	Oct. 02, 2023	Oct. 01, 2024	Conducted (TH01-CB)
RF Cable-high	Woken	RG402	High Cable-09	1 GHz – 18 GHz	Oct. 02, 2023	Oct. 01, 2024	Conducted (TH01-CB)
RF Cable-high	Woken	RG402	High Cable-10	1 GHz – 18 GHz	Oct. 02, 2023	Oct. 01, 2024	Conducted (TH01-CB)
RF Cable-high	Woken	RG402	High Cable-30	1 GHz – 18 GHz	Oct. 02, 2023	Oct. 01, 2024	Conducted (TH01-CB)



Instrument	Brand	Model No.	Serial No.	Characteristics	Calibration Date	Calibration Due Date	Remark
Power Sensor	Anritsu	MA2411B	1339408	300MHz~40GHz	Sep. 12, 2023	Sep. 11, 2024	Conducted (TH01-CB)
Power Meter	Anritsu	ML2495A	1517009	300MHz~40GHz	Sep. 12, 2023	Sep. 11, 2024	Conducted (TH01-CB)
Test Software	SPORTON	SENSE	V5.10	-	N.C.R.	N.C.R.	Conducted (TH01-CB)

Note: Calibration Interval of instruments listed above is one year.

N.C.R means Non-Calibration required.



Summary

Mode	Result	Type	Freq (Hz)	Level (dBuV)	Limit (dBuV)	Margin (dB)	Condition
Mode 8	Pass	AV	12.638M	46.38	50.00	-3.62	Line

Mode 8

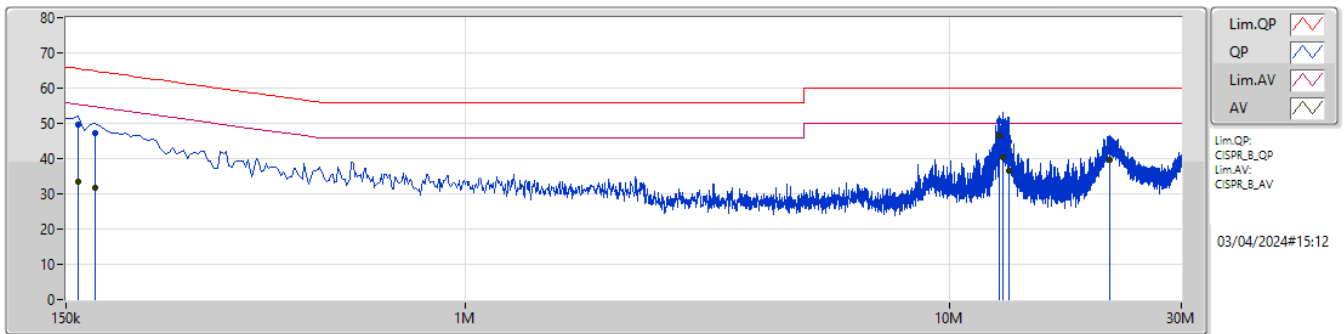

Type	Freq (Hz)	Level (dBuV)	Limit (dBuV)	Margin (dB)	Factor (dB)	Condition	Comment	Raw (dBuV)	LISN (dB)	CL (dB)	AT (dB)
QP	159k	49.59	65.52	-15.93	9.97	Line	-	39.62	0.09	0.02	9.86
AV	159k	33.52	55.52	-22.00	9.97	Line	-	23.55	0.09	0.02	9.86
QP	172.5k	47.33	64.83	-17.50	9.97	Line	-	37.36	0.09	0.02	9.86
AV	172.5k	31.73	54.83	-23.10	9.97	Line	-	21.76	0.09	0.02	9.86
QP	12.638M	50.77	60.00	-9.23	10.36	Line	-	40.41	0.27	0.16	9.93
AV	12.638M	46.38	50.00	-3.62	10.36	Line	"Worst"	36.02	0.27	0.16	9.93
QP	12.854M	50.27	60.00	-9.73	10.36	Line	-	39.91	0.27	0.16	9.93
AV	12.854M	40.39	50.00	-9.61	10.36	Line	-	30.03	0.27	0.16	9.93
QP	13.236M	44.91	60.00	-15.09	10.38	Line	-	34.53	0.27	0.17	9.94
AV	13.236M	36.68	50.00	-13.32	10.38	Line	-	26.30	0.27	0.17	9.94
QP	21.404M	45.61	60.00	-14.39	10.56	Line	-	35.05	0.30	0.23	10.03
AV	21.404M	39.67	50.00	-10.33	10.56	Line	-	29.11	0.30	0.23	10.03

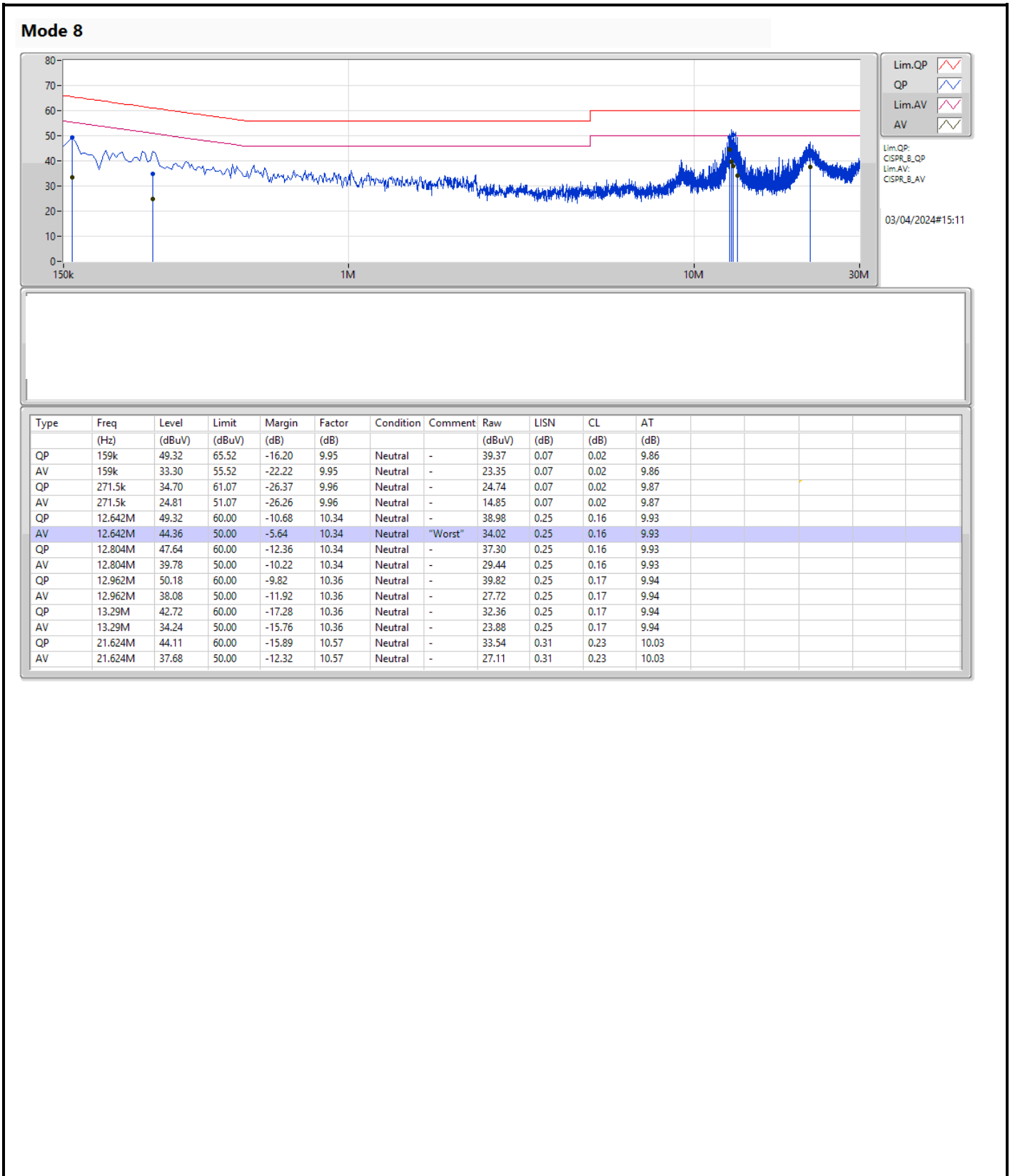



Summary

Mode	Max-N dB (Hz)	Max-OBW (Hz)	ITU-Code	Min-N dB (Hz)	Min-OBW (Hz)
2.4-2.4835GHz	-	-	-	-	-
BT-LE(1Mbps)	725k	1.043M	1M04F1D	687.5k	1.023M
BT-LE(2Mbps)	1.44M	2.08M	2M08F1D	755k	2.06M

Max-N dB = Maximum 6dB down bandwidth; Max-OBW = Maximum 99% occupied bandwidth;
Min-N dB = Minimum 6dB down bandwidth; Min-OBW = Minimum 99% occupied bandwidth



Result

Mode	Result	Limit (Hz)	Port 1-N dB (Hz)	Port 1-OBW (Hz)
BT-LE(1Mbps)	-	-	-	-
2402MHz	Pass	500k	725k	1.04M
2440MHz	Pass	500k	687.5k	1.043M
2480MHz	Pass	500k	722.5k	1.023M
BT-LE(2Mbps)	-	-	-	-
2402MHz	Pass	500k	1.233M	2.078M
2440MHz	Pass	500k	1.44M	2.08M
2480MHz	Pass	500k	755k	2.06M

Port X-N dB = Port X 6dB down bandwidth;
Port X-OBW = Port X 99% occupied bandwidth

2.4-2.4835GHz_BT-LE(1Mbps)

EBW-DTS

2402MHz

15/01/2024

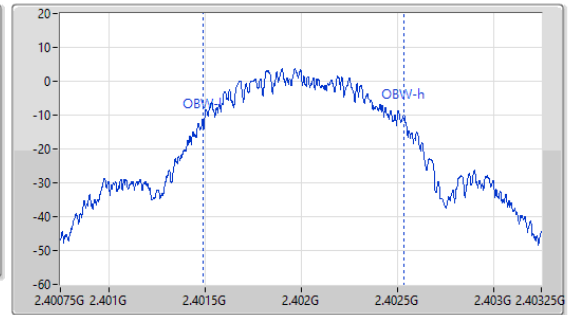
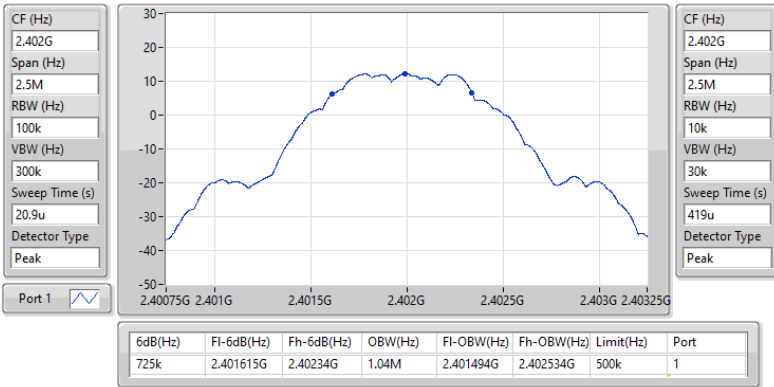

2.4-2.4835GHz_BT-LE(1Mbps)

EBW-DTS

2440MHz

15/01/2024

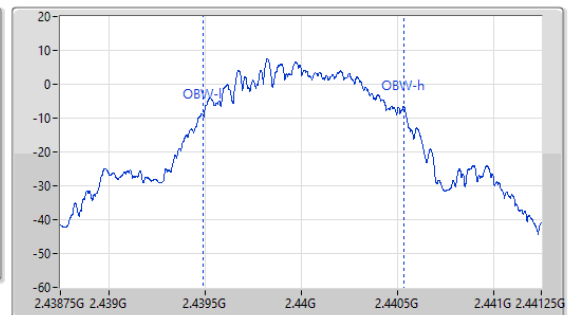
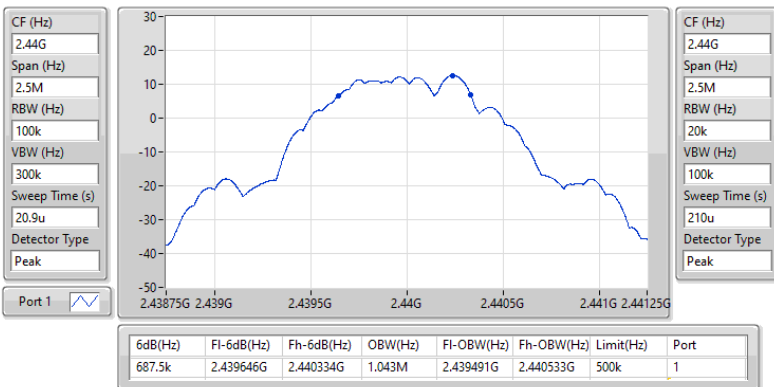

2.4-2.4835GHz_BT-LE(1Mbps)

EBW-DTS

2480MHz

15/01/2024

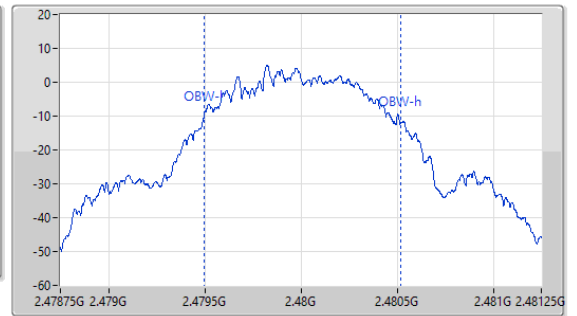
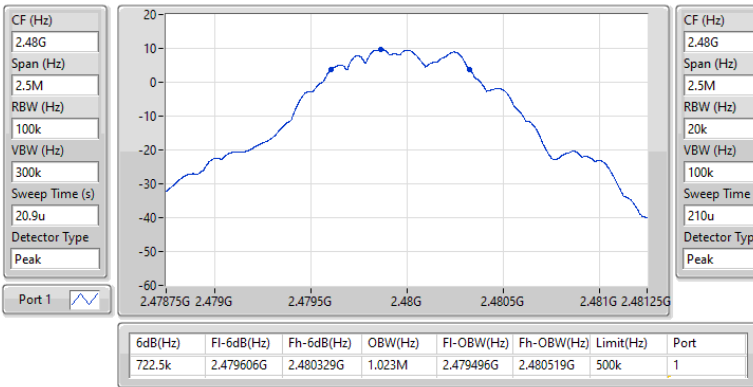

2.4-2.4835GHz_BT-LE(2Mbps)

EBW-DTS

2402MHz

15/01/2024

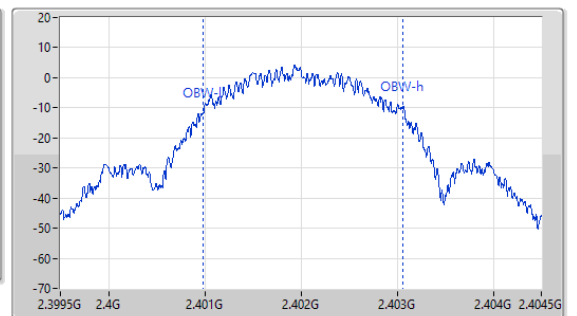
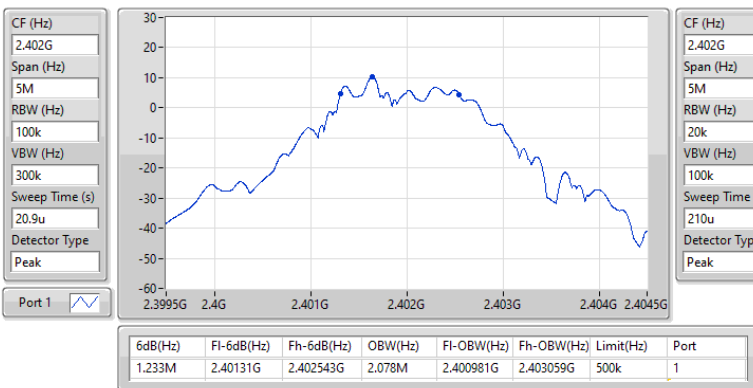

2.4-2.4835GHz_BT-LE(2Mbps)

EBW-DTS

2440MHz

15/01/2024

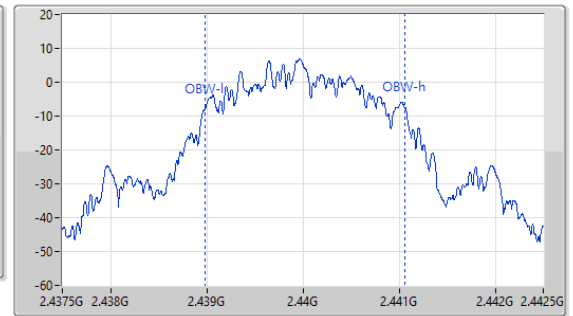
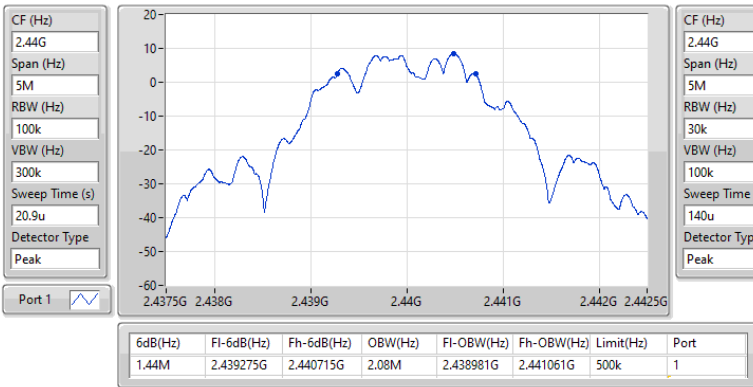

2.4-2.4835GHz_BT-LE(2Mbps)

EBW-DTS

2480MHz

15/01/2024

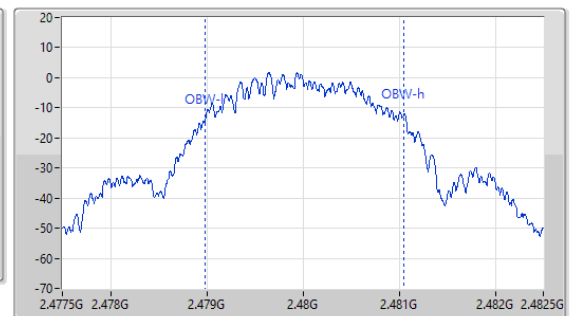
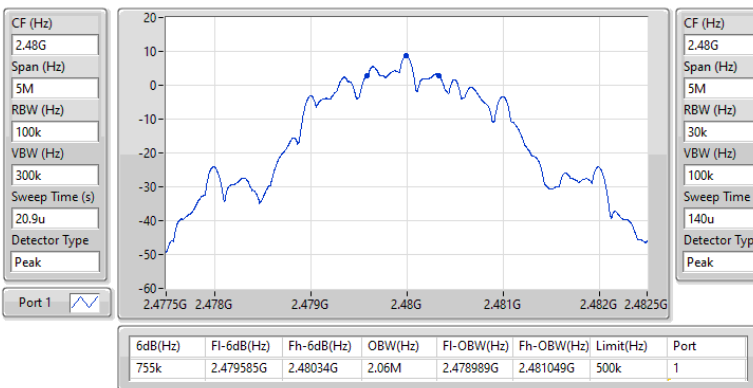



Summary

Mode	Total Power (dBm)	Total Power (W)
2.4-2.4835GHz	-	-
BT-LE(1Mbps)	13.98	0.02500
BT-LE(2Mbps)	13.92	0.02466



Result

Mode	Result	DG (dBi)	Total Power (dBm)	Power Limit (dBm)
BT-LE(1Mbps)	-	-	-	-
2402MHz	Pass	4.22	13.98	30.00
2440MHz	Pass	4.22	13.91	30.00
2480MHz	Pass	4.22	11.68	30.00
BT-LE(2Mbps)	-	-	-	-
2402MHz	Pass	4.22	13.84	30.00
2440MHz	Pass	4.22	13.92	30.00
2478MHz	Pass	4.22	13.75	30.00
2480MHz	Pass	4.22	9.28	30.00

DG = Directional Gain; Port X = Port X output power



Summary

Mode	PD (dBm/RBW)
2.4-2.4835GHz	-
BT-LE(1Mbps)	-1.56
BT-LE(2Mbps)	-3.54

RBW = 3kHz;



Result

Mode	Result	DG (dBi)	PD (dBm/RBW)	PD Limit (dBm/RBW)
BT-LE(1Mbps)	-	-	-	-
2402MHz	Pass	4.22	-1.56	8.00
2440MHz	Pass	4.22	-1.71	8.00
2480MHz	Pass	4.22	-4.04	8.00
BT-LE(2Mbps)	-	-	-	-
2402MHz	Pass	4.22	-3.54	8.00
2440MHz	Pass	4.22	-3.76	8.00
2480MHz	Pass	4.22	-8.21	8.00

DG = Directional Gain; RBW = 3kHz;
PD = trace bin-by-bin of each transmits port summing can be performed maximum power density; Port X = Port X Power Density;

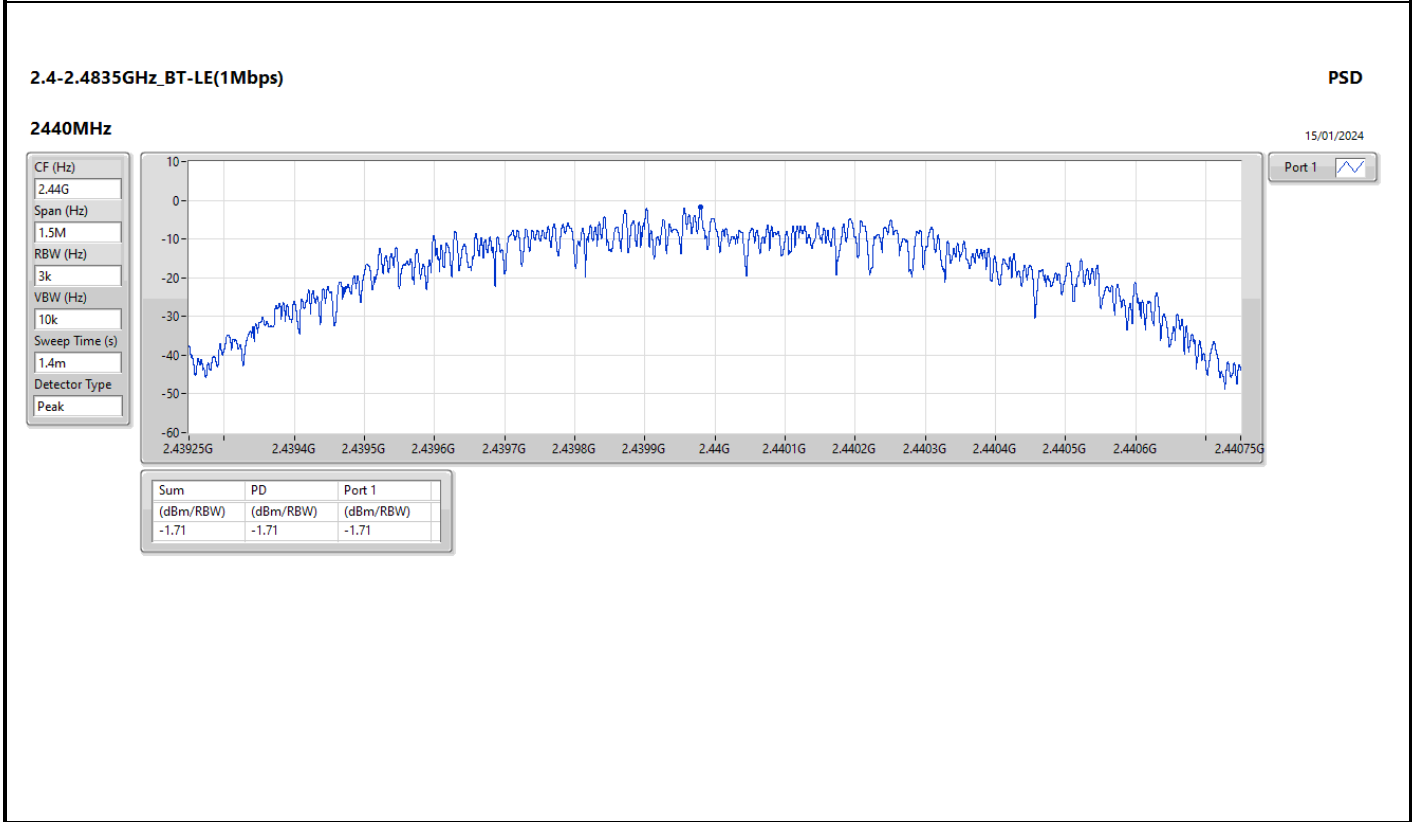
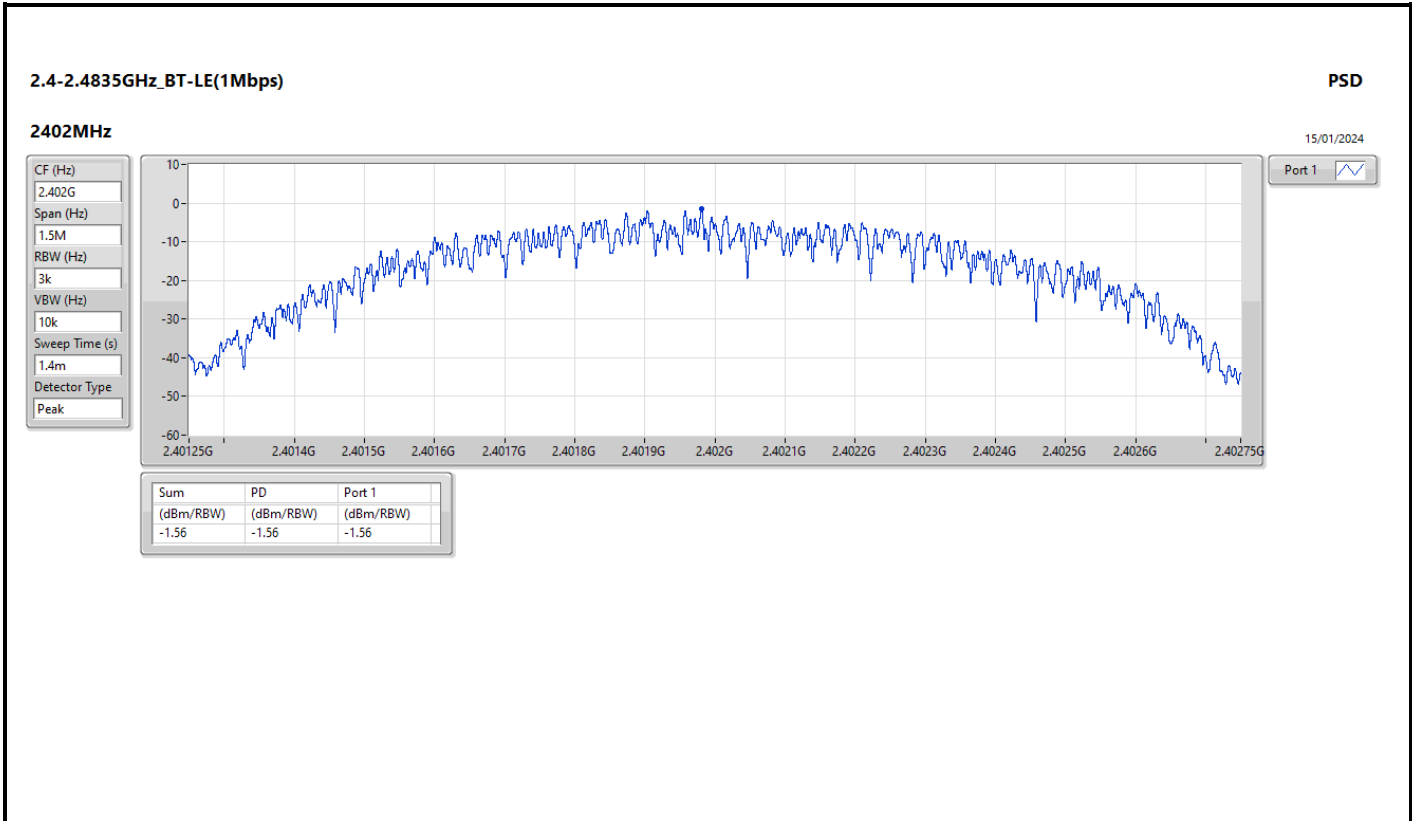

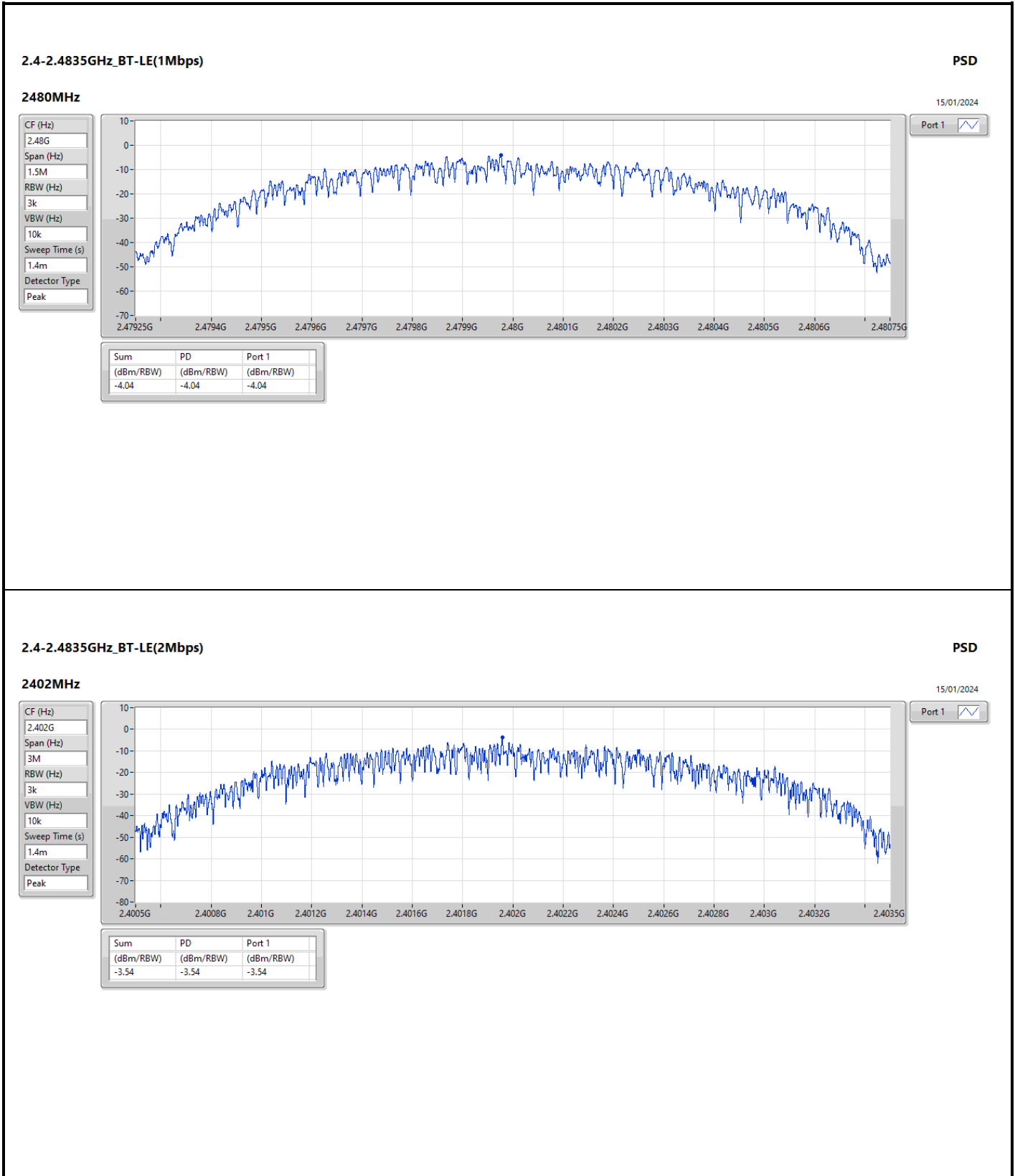

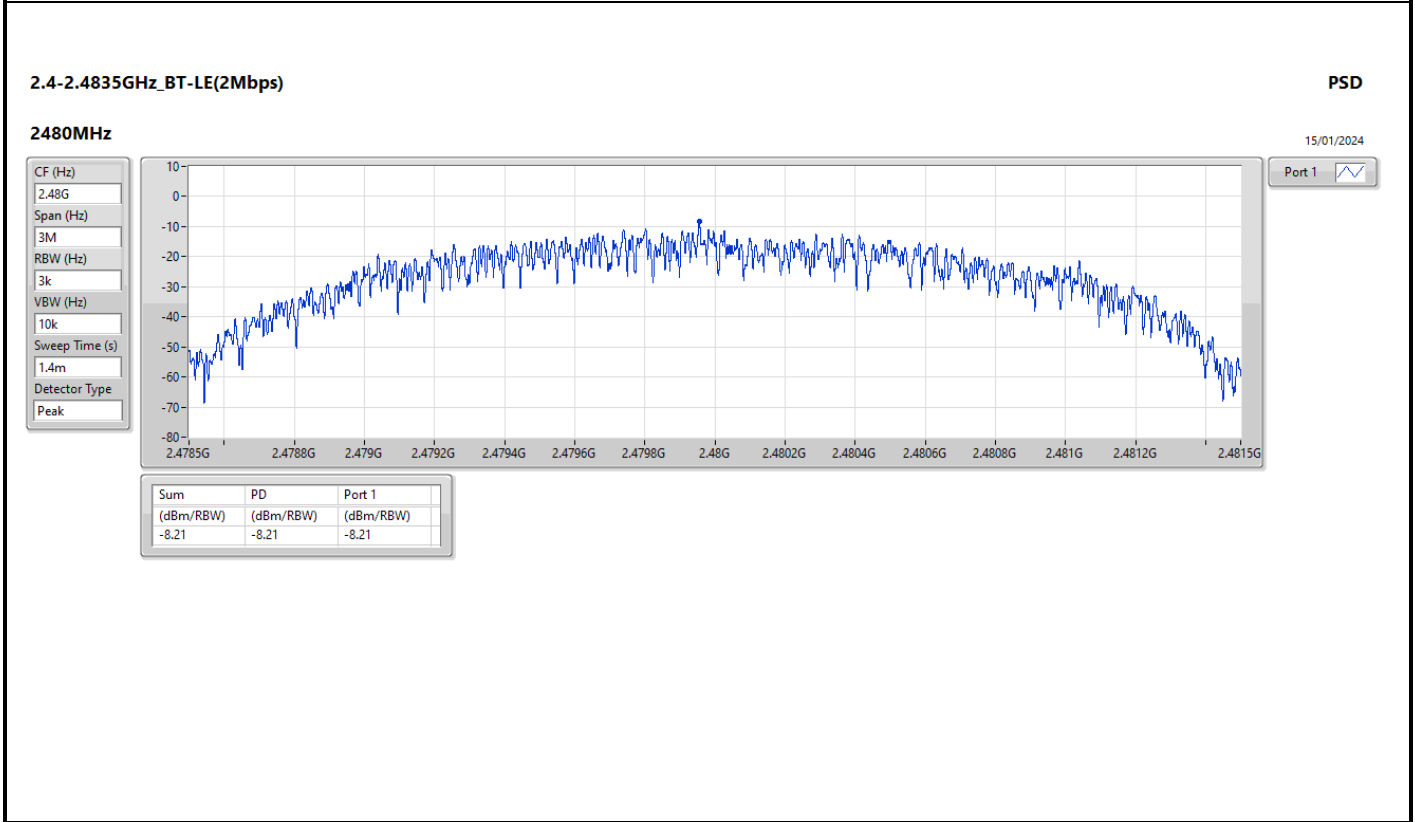
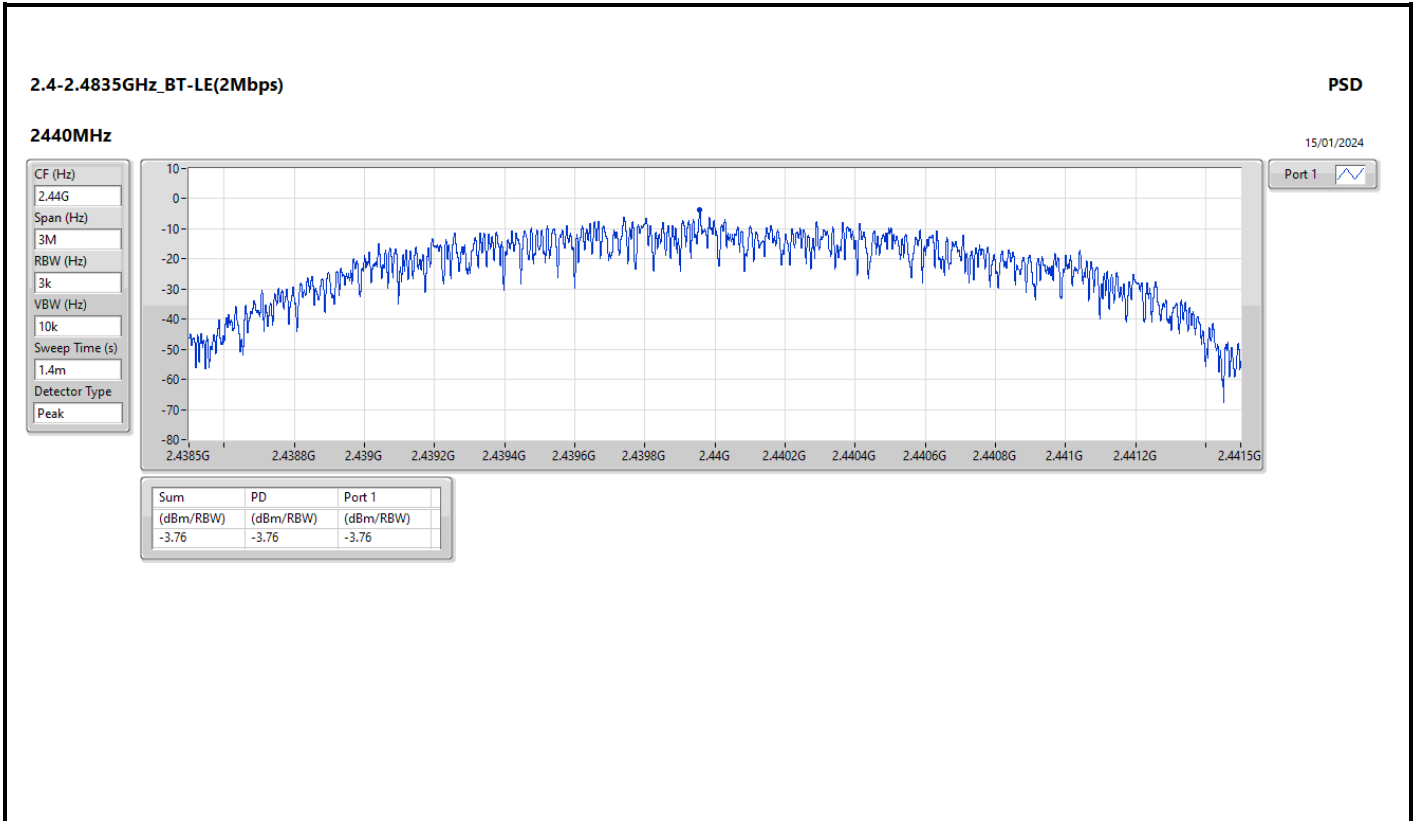



Summary

Mode	Result	Ref (Hz)	Ref (dBm)	Limit (dBm)	Freq (Hz)	Level (dBm)	Freq (Hz)	Level (dBm)	Freq (Hz)	Level (dBm)	Freq (Hz)	Level (dBm)	Freq (Hz)	Level (dBm)	Port
2.4-2.4835GHz	-	-	-	-	-	-	-	-	-	-	-	-	-	-	-
BT-LE(1Mbps)	Pass	2.40217G	13.10	-16.90	1.88533G	-52.69	2.4G	-41.02	2.4G	-38.97	2.50002G	-52.20	21.97703G	-47.69	1
BT-LE(2Mbps)	Pass	2.43991G	13.11	-16.89	59.38M	-51.75	2.4G	-19.33	2.4G	-20.78	2.50126G	-52.23	21.46805G	-46.69	1

Result

Mode	Result	Ref (Hz)	Ref (dBm)	Limit (dBm)	Freq (Hz)	Level (dBm)	Freq (Hz)	Level (dBm)	Freq (Hz)	Level (dBm)	Freq (Hz)	Level (dBm)	Freq (Hz)	Level (dBm)	Port
BT-LE(1Mbps)	-	-	-	-	-	-	-	-	-	-	-	-	-	-	-
2402MHz	Pass	2.40217G	13.10	-16.90	1.88533G	-52.69	2.4G	-41.02	2.4G	-38.97	2.50002G	-52.20	21.97703G	-47.69	1
2440MHz	Pass	2.40217G	13.10	-16.90	79.35M	-53.66	2.39632G	-52.20	2.4G	-57.45	2.50322G	-51.98	21.88142G	-48.09	1
2480MHz	Pass	2.40217G	13.10	-16.90	122.83M	-52.03	2.39428G	-51.51	2.4G	-57.03	2.50254G	-51.54	21.66208G	-47.28	1
BT-LE(2Mbps)	-	-	-	-	-	-	-	-	-	-	-	-	-	-	-
2402MHz	Pass	2.43991G	13.11	-16.89	59.38M	-51.75	2.4G	-19.33	2.4G	-20.78	2.50126G	-52.23	21.46805G	-46.69	1
2440MHz	Pass	2.43991G	13.11	-16.89	1.78545G	-54.02	2.39008G	-50.52	2.4G	-57.07	2.50286G	-52.02	21.92923G	-47.67	1
2480MHz	Pass	2.43991G	13.11	-16.89	1.98638G	-53.79	2.39236G	-51.76	2.4G	-56.18	2.50234G	-52.19	21.97703G	-48.23	1

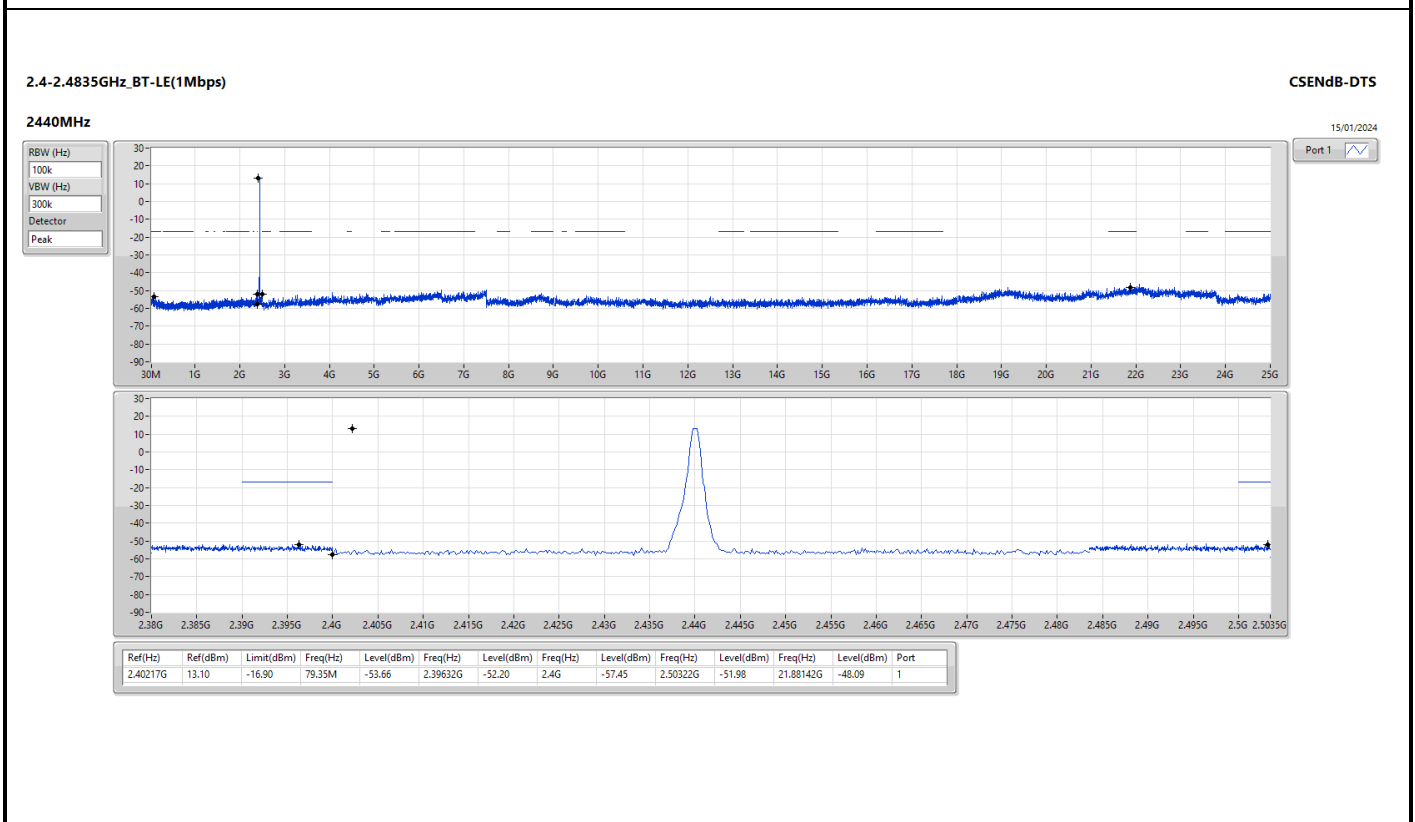
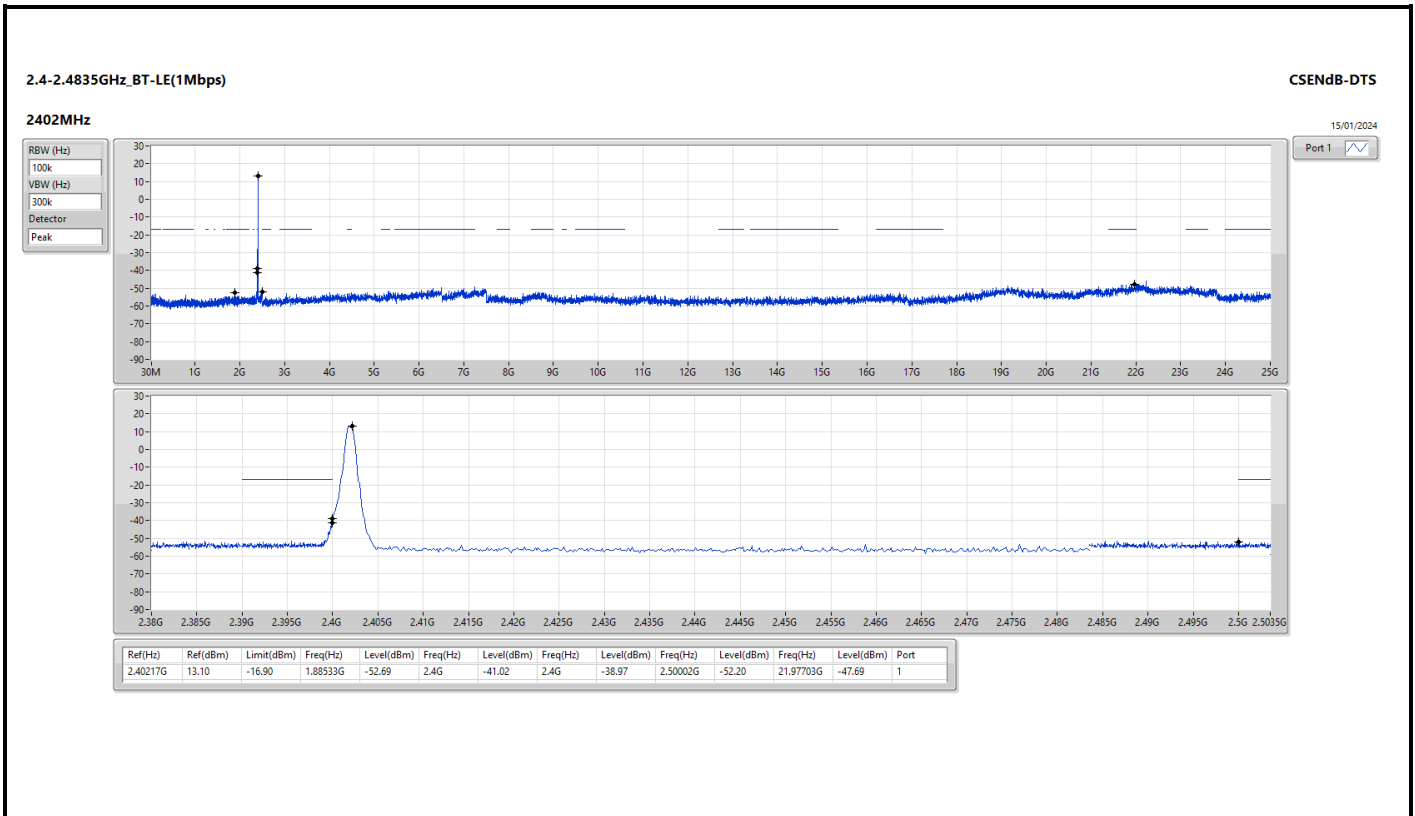

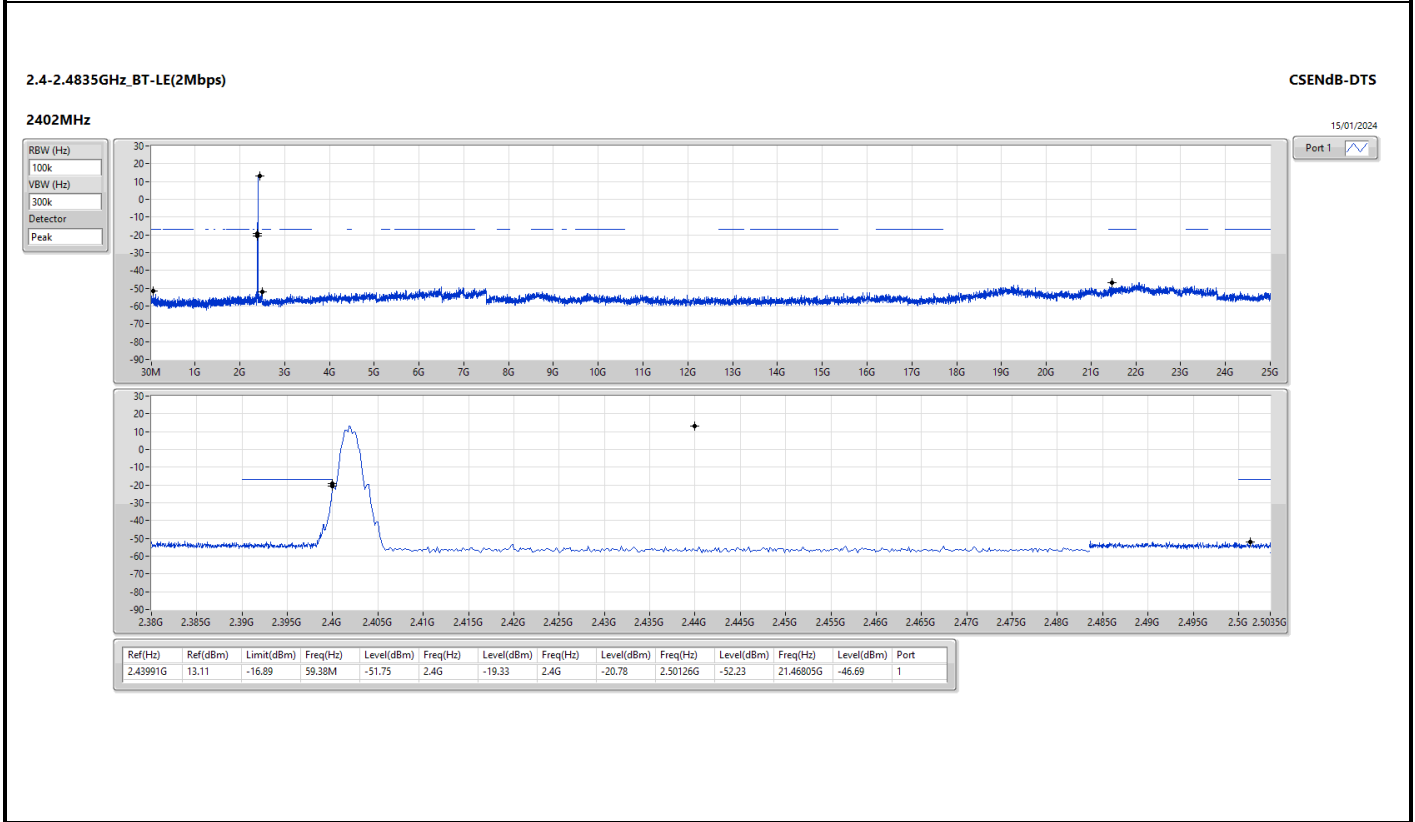
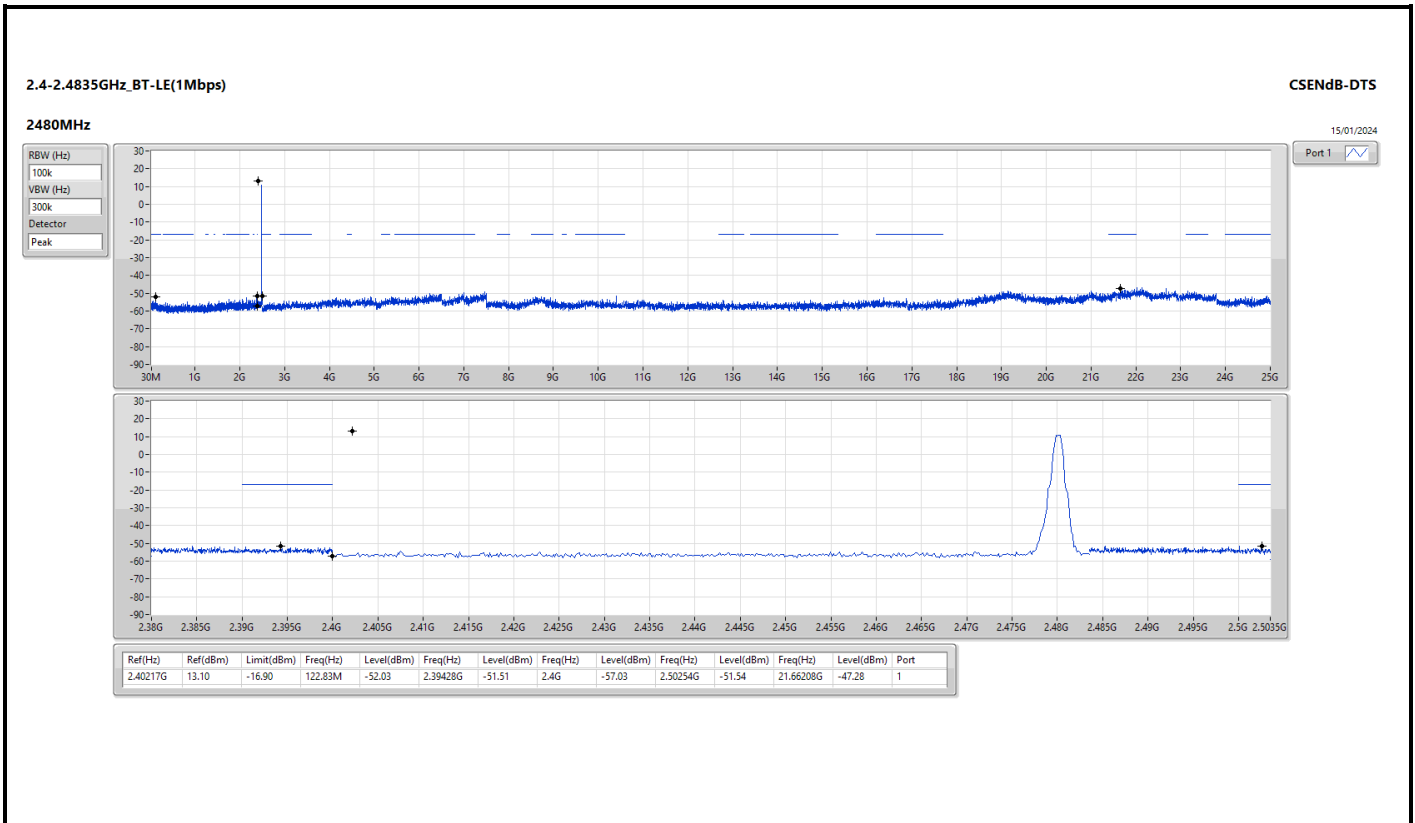

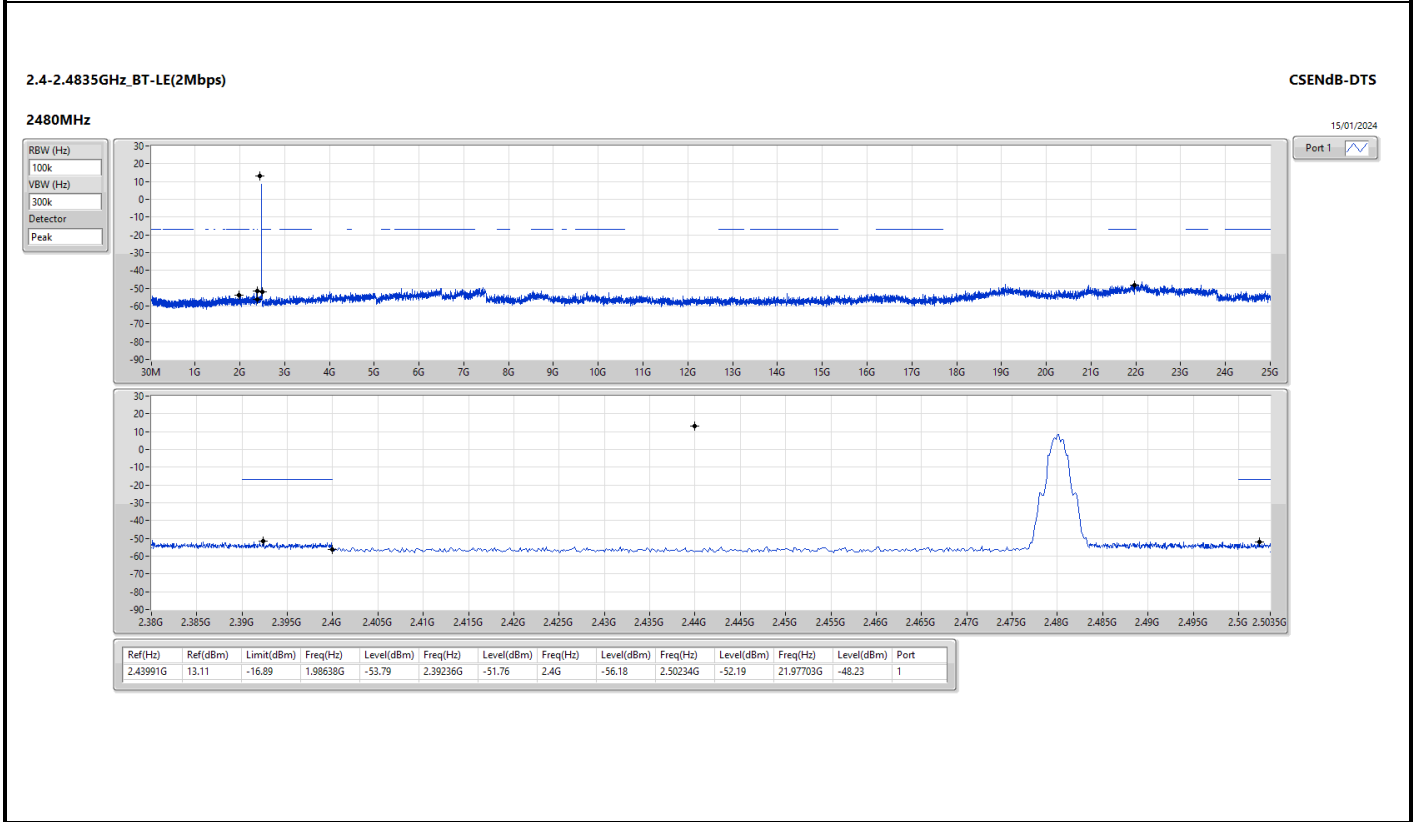
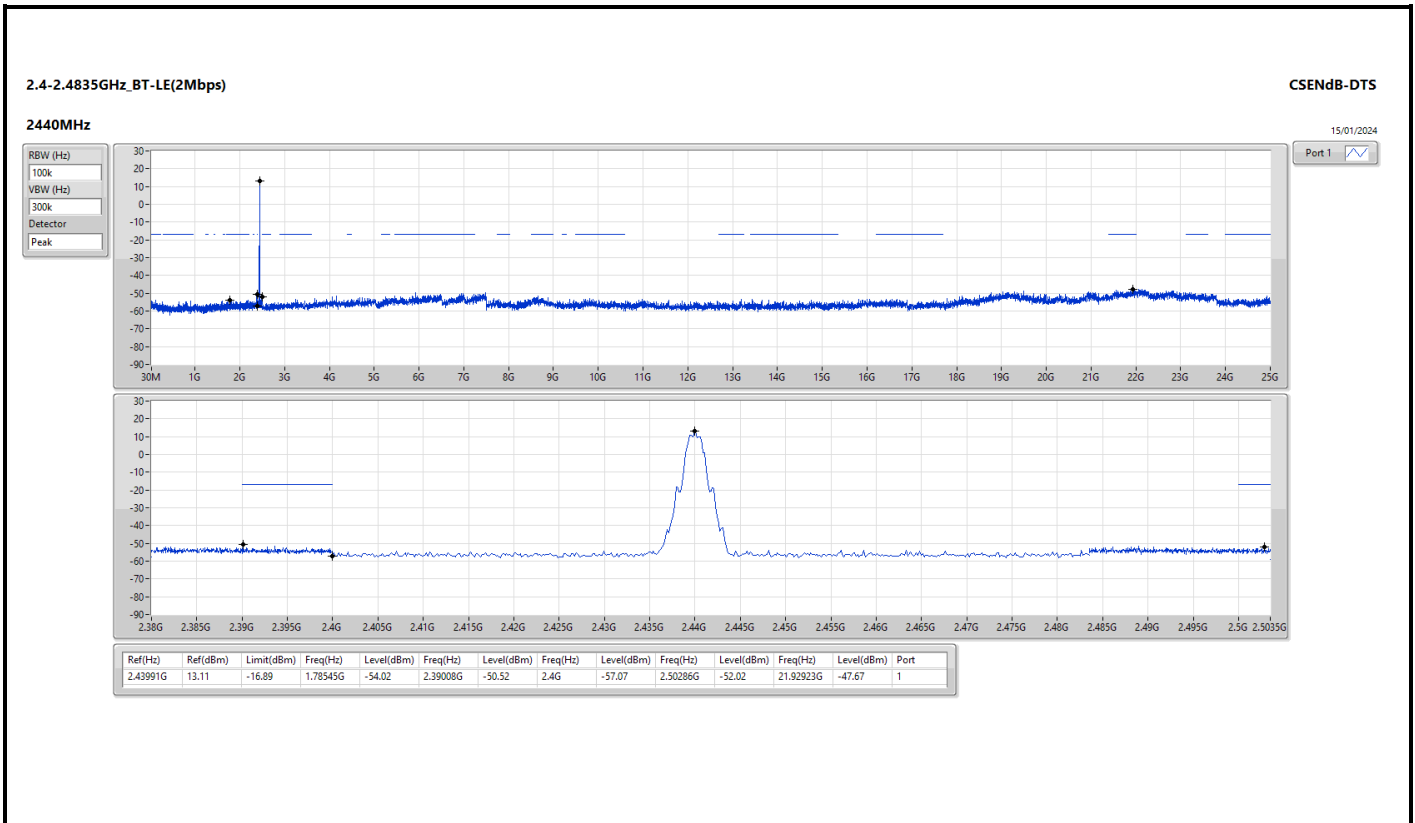



Summary

Mode	Result	Type	Freq (Hz)	Level (dBuV/m)	Limit (dBuV/m)	Margin (dB)	Condition
Mode 1	Pass	PK	60.07M	36.71	40.00	-3.29	Vertical

Mode 1

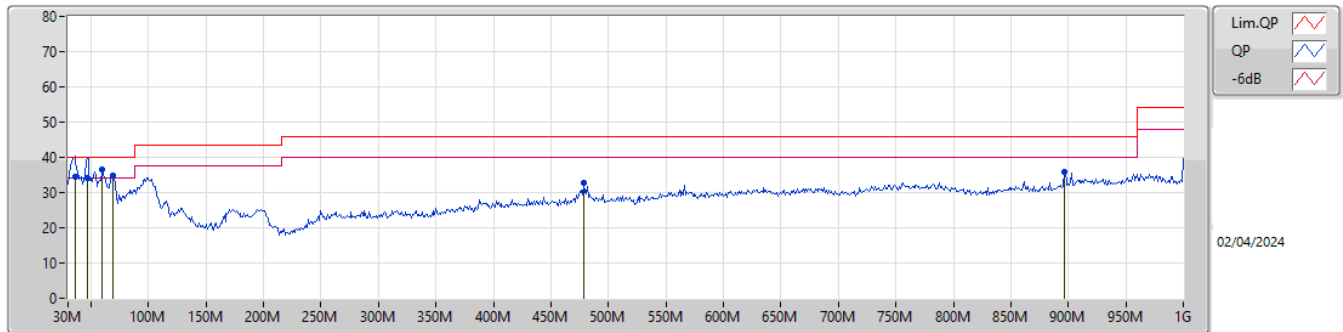

Type	Freq (Hz)	Level (dBuV/m)	Limit (dBuV/m)	Margin (dB)	Factor (dB/m)	Dist (m)	Condition	Azimuth (°)	Height (m)	Comment	Raw (dBuV/m)	AF (dB/m)	CL (dB)	PA (dB)
QP	35.82M	34.63	40.00	-5.37	-10.07	3	Vertical	262	1.00	"	44.70	21.13	1.21	32.41
QP	46.49M	34.28	40.00	-5.72	-15.02	3	Vertical	162	1.00	-	49.30	16.02	1.31	32.35
PK	60.07M	36.71	40.00	-3.29	-18.33	3	Vertical	0	1.25	"Worst"	55.04	12.53	1.41	32.27
PK	68.8M	34.98	40.00	-5.02	-18.45	3	Vertical	265	2.00	-	53.43	12.37	1.47	32.29
PK	479.11M	32.80	46.00	-13.20	-5.69	3	Vertical	66	2.00	-	38.49	23.17	3.19	32.05
PK	896.21M	35.94	46.00	-10.06	-0.83	3	Vertical	255	1.25	-	36.77	26.44	4.31	31.58

Mode 1

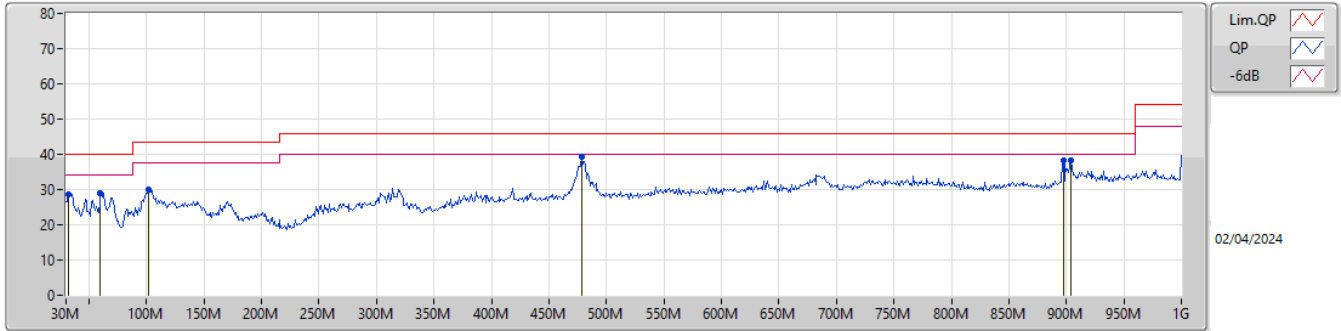

Type	Freq (Hz)	Level (dBuV/m)	Limit (dBuV/m)	Margin (dB)	Factor (dB/m)	Dist (m)	Condition	Azimuth (°)	Height (m)	Comment	Raw (dBuV/m)	AF (dB/m)	CL (dB)	PA (dB)
PK	31.94M	28.75	40.00	-11.25	-8.14	3	Horizontal	0	1.50	-	36.89	23.10	1.16	32.40
PK	60.07M	29.00	40.00	-11.00	-18.33	3	Horizontal	87	2.00	-	47.33	12.53	1.41	32.27
PK	101.78M	29.85	43.50	-13.65	-13.57	3	Horizontal	291	3.00	-	43.42	17.10	1.68	32.35
PK	479.11M	39.32	46.00	-6.68	-5.69	3	Horizontal	360	2.00	"Worst"	45.01	23.17	3.19	32.05
PK	897.18M	38.33	46.00	-7.67	-0.80	3	Horizontal	96	1.50	-	39.13	26.46	4.31	31.57
PK	903.97M	38.34	46.00	-7.66	-0.70	3	Horizontal	360	1.25	-	39.04	26.42	4.33	31.45



Summary

Mode	Result	Type	Freq (Hz)	Level (dBuV/m)	Limit (dBuV/m)	Margin (dB)	Dist (m)	Condition	Azimuth (°)	Height (m)	Comments
2.4-2.4835GHz	-	-	-	-	-	-	-	-	-	-	-
BT-LE(2Mbps)	Pass	AV	2.4835G	53.64	54.00	-0.36	3	Vertical	308	2.60	-

2.4-2.4835GHz_BT-LE(1Mbps)

2402MHz_TX

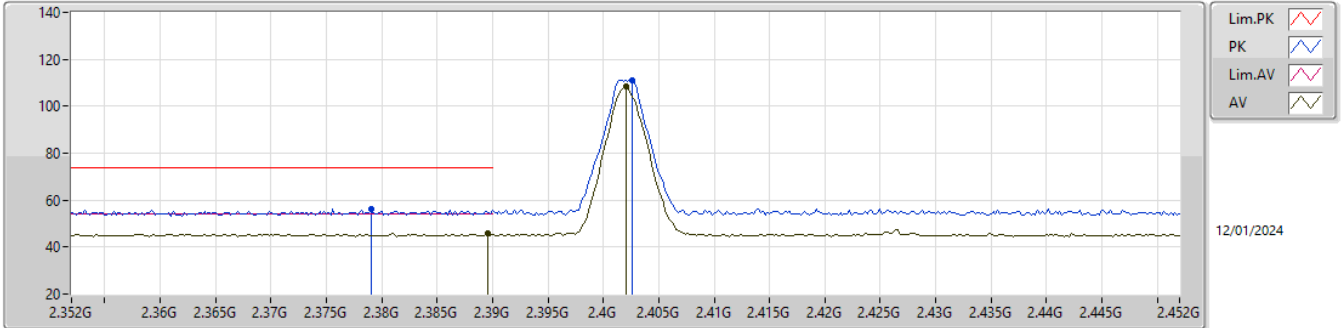

EUTZ_1TX
 Setting 0C 0C
 01-C-G-5

Type	Freq (Hz)	Level (dBuV/m)	Limit (dBuV/m)	Margin (dB)	Raw (dBuV)	Dist (m)	Condition	Azimuth (°)	Height (m)	Comment	AF (dB)	CL (dB)	PA (dB)
PK	2.379G	56.13	74.00	-17.87	24.69	3	Vertical	294	2.77	-	28.39	3.05	-
AV	2.3896G	45.71	54.00	-8.29	14.26	3	Vertical	294	2.77	-	28.40	3.05	-
PK	2.4026G	111.28	Inf	-Inf	79.82	3	Vertical	294	2.77	-	28.40	3.06	-
AV	2.402G	108.30	Inf	-Inf	76.84	3	Vertical	294	2.77	-	28.40	3.06	-

2.4-2.4835GHz_BT-LE(1Mbps)

2402MHz_TX

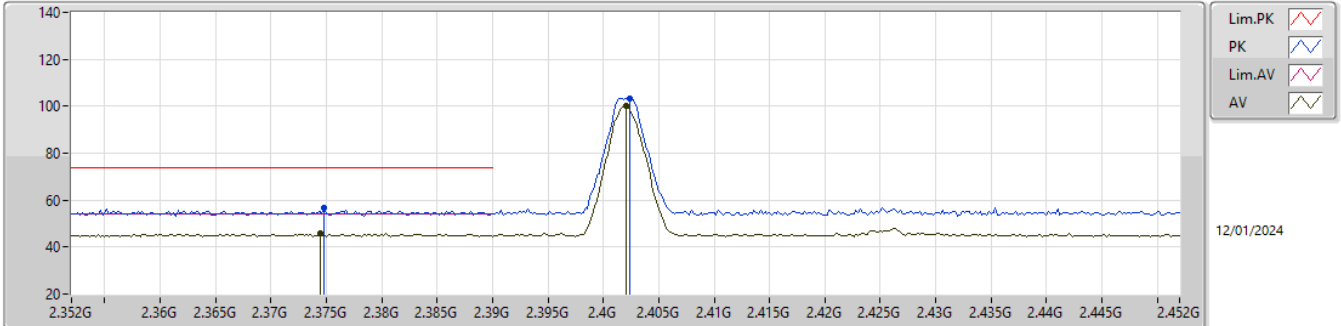

EUTZ_1TX
 Setting 0C 0C
 01-C-G-5

Type	Freq (Hz)	Level (dBuV/m)	Limit (dBuV/m)	Margin (dB)	Raw (dBuV)	Dist (m)	Condition	Azimuth (°)	Height (m)	Comment	AF (dB)	CL (dB)	PA (dB)
PK	2.3748G	56.50	74.00	-17.50	25.10	3	Horizontal	151	2.56	-	28.35	3.05	-
AV	2.3744G	45.80	54.00	-8.20	14.41	3	Horizontal	151	2.56	-	28.34	3.05	-
PK	2.4024G	103.29	Inf	-Inf	71.83	3	Horizontal	151	2.56	-	28.40	3.06	-
AV	2.402G	100.26	Inf	-Inf	68.80	3	Horizontal	151	2.56	-	28.40	3.06	-

2.4-2.4835GHz_BT-LE(1Mbps)

2402MHz_TX

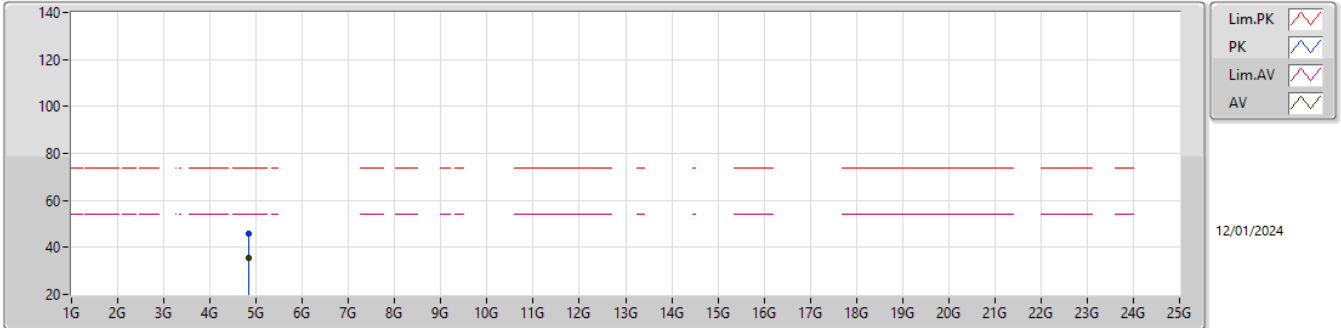

EUTZ_1TX
 Setting 0C 0C
 01-C-G-5

Type	Freq (Hz)	Level (dBuV/m)	Limit (dBuV/m)	Margin (dB)	Raw (dBuV)	Dist (m)	Condition	Azimuth (°)	Height (m)	Comment	AF (dB)	CL (dB)	PA (dB)
PK	4.827G	45.96	74.00	-28.04	38.57	3	Vertical	88	2.42	-	32.96	5.10	30.67
AV	4.8486G	35.41	54.00	-18.59	27.88	3	Vertical	88	2.42	-	33.09	5.10	30.66

2.4-2.4835GHz_BT-LE(1Mbps)

2402MHz_TX

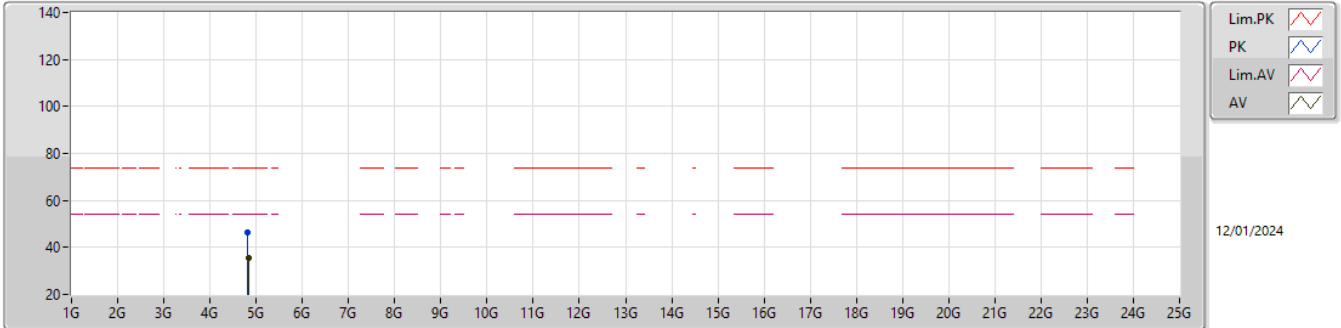

EUTZ_1TX
 Setting 0C 0C
 01-C-G-5

Type	Freq (Hz)	Level (dBuV/m)	Limit (dBuV/m)	Margin (dB)	Raw (dBuV)	Dist (m)	Condition	Azimuth (°)	Height (m)	Comment	AF (dB)	CL (dB)	PA (dB)
PK	4.8188G	46.49	74.00	-27.51	39.16	3	Horizontal	342	2.95	-	32.91	5.10	30.68
AV	4.8256G	35.35	54.00	-18.65	27.98	3	Horizontal	342	2.95	-	32.95	5.10	30.68

2.4-2.4835GHz_BT-LE(1Mbps)

2440MHz_TX

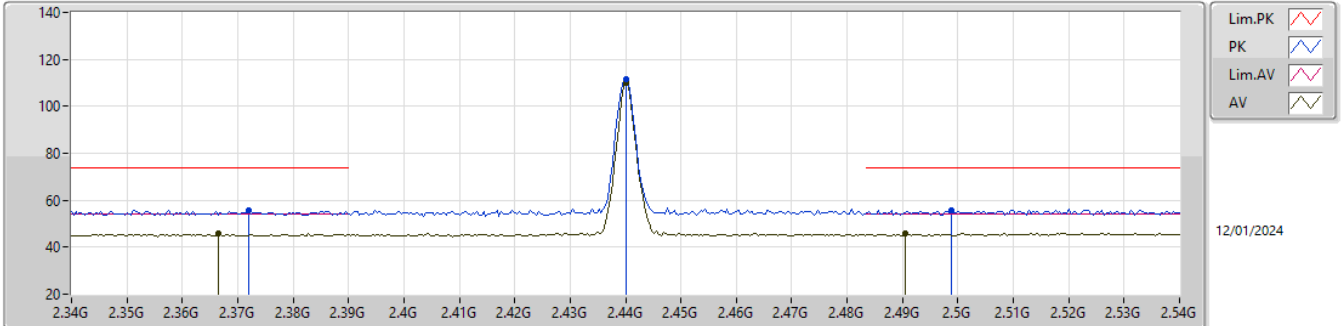

EUTZ_1TX
 Setting 0C 0C
 01-C-G-5

Type	Freq (Hz)	Level (dBuV/m)	Limit (dBuV/m)	Margin (dB)	Raw (dBuV)	Dist (m)	Condition	Azimuth (°)	Height (m)	Comment	AF (dB)	CL (dB)	PA (dB)
PK	2.372G	55.64	74.00	-18.36	24.27	3	Vertical	34	2.97	-	28.32	3.05	-
AV	2.3664G	45.65	54.00	-8.35	14.35	3	Vertical	34	2.97	-	28.26	3.04	-
PK	2.44G	111.37	Inf	-Inf	79.89	3	Vertical	34	2.97	-	28.40	3.08	-
AV	2.44G	110.19	Inf	-Inf	78.71	3	Vertical	34	2.97	-	28.40	3.08	-
PK	2.4988G	55.67	74.00	-18.33	23.98	3	Vertical	34	2.97	-	28.59	3.10	-
AV	2.4904G	45.69	54.00	-8.31	14.09	3	Vertical	34	2.97	-	28.50	3.10	-

2.4-2.4835GHz_BT-LE(1Mbps)

2440MHz_TX

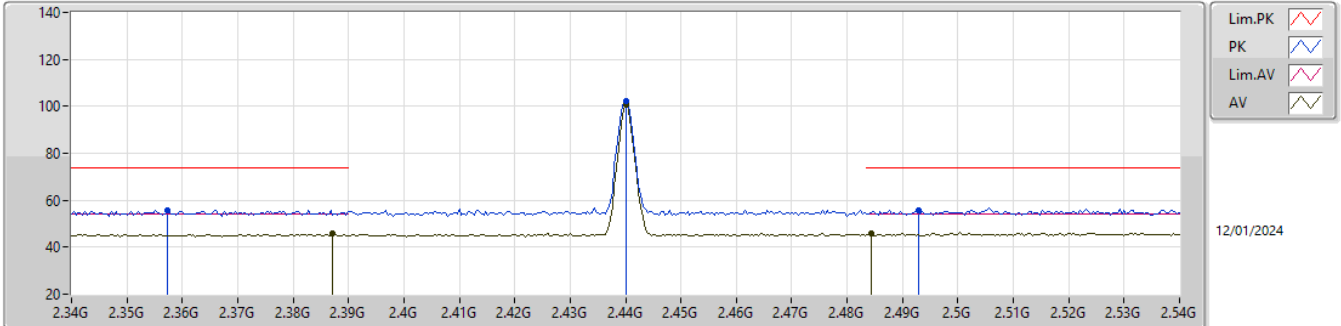

EUTZ_1TX
 Setting 0C 0C
 01-C-G-5

Type	Freq (Hz)	Level (dBuV/m)	Limit (dBuV/m)	Margin (dB)	Raw (dBuV)	Dist (m)	Condition	Azimuth (°)	Height (m)	Comment	AF (dB)	CL (dB)	PA (dB)
PK	2.3572G	55.71	74.00	-18.29	24.47	3	Horizontal	294	1.53	-	28.20	3.04	-
AV	2.3872G	45.61	54.00	-8.39	14.16	3	Horizontal	294	1.53	-	28.40	3.05	-
PK	2.44G	102.01	Inf	-Inf	70.53	3	Horizontal	294	1.53	-	28.40	3.08	-
AV	2.44G	100.77	Inf	-Inf	69.29	3	Horizontal	294	1.53	-	28.40	3.08	-
PK	2.4928G	55.56	74.00	-18.44	23.93	3	Horizontal	294	1.53	-	28.53	3.10	-
AV	2.4844G	45.73	54.00	-8.27	14.14	3	Horizontal	294	1.53	-	28.50	3.09	-

2.4-2.4835GHz_BT-LE(1Mbps)

2440MHz_TX

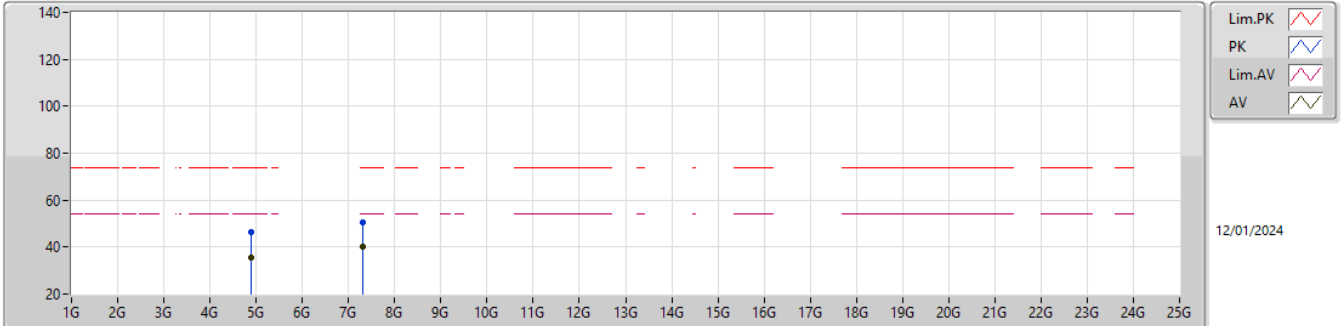

EUTZ_1TX
 Setting 0C 0C
 01-C-G-5

Type	Freq (Hz)	Level (dBuV/m)	Limit (dBuV/m)	Margin (dB)	Raw (dBuV)	Dist (m)	Condition	Azimuth (°)	Height (m)	Comment	AF (dB)	CL (dB)	PA (dB)
PK	4.88008G	46.23	74.00	-27.77	38.60	3	Vertical	297	2.88	-	33.16	5.11	30.64
AV	4.88128G	35.75	54.00	-18.25	28.12	3	Vertical	297	2.88	-	33.16	5.11	30.64
PK	7.32012G	50.56	74.00	-23.44	39.52	3	Vertical	219	2.06	-	36.64	6.52	32.12
AV	7.31848G	40.28	54.00	-13.72	29.24	3	Vertical	219	2.06	-	36.64	6.52	32.12

2.4-2.4835GHz_BT-LE(1Mbps)

2440MHz_TX

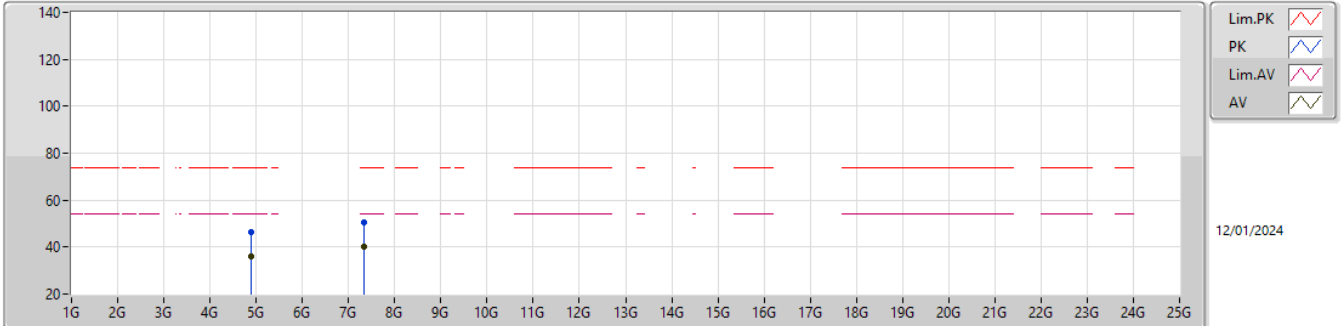

EUTZ_1TX
 Setting 0C 0C
 01-C-G-5

Type	Freq (Hz)	Level (dBuV/m)	Limit (dBuV/m)	Margin (dB)	Raw (dBuV)	Dist (m)	Condition	Azimuth (°)	Height (m)	Comment	AF (dB)	CL (dB)	PA (dB)
PK	4.8824G	46.60	74.00	-27.40	38.97	3	Horizontal	313	2.57	-	33.16	5.11	30.64
AV	4.88932G	36.10	54.00	-17.90	28.43	3	Horizontal	313	2.57	-	33.18	5.12	30.63
PK	7.32236G	50.54	74.00	-23.46	39.50	3	Horizontal	244	2.44	-	36.64	6.52	32.12
AV	7.3228G	40.13	54.00	-13.87	29.08	3	Horizontal	244	2.44	-	36.65	6.52	32.12

2.4-2.4835GHz_BT-LE(1Mbps)

2480MHz_TX

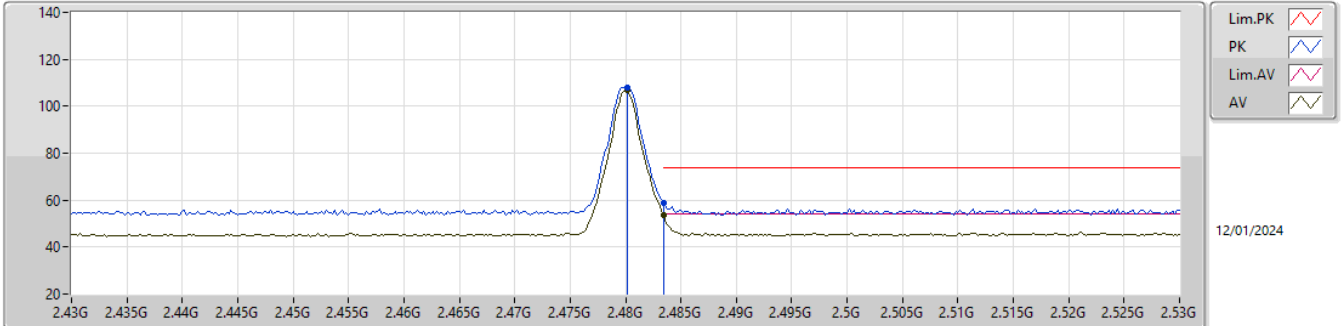

EUTZ_1TX
 Setting 09 09
 01-C-G-5

Type	Freq (Hz)	Level (dBuV/m)	Limit (dBuV/m)	Margin (dB)	Raw (dBuV)	Dist (m)	Condition	Azimuth (°)	Height (m)	Comment	AF (dB)	CL (dB)	PA (dB)
PK	2.4802G	108.00	Inf	-Inf	76.41	3	Vertical	306	2.61	-	28.50	3.09	-
AV	2.4802G	106.96	Inf	-Inf	75.37	3	Vertical	306	2.61	-	28.50	3.09	-
PK	2.4835G	58.98	74.00	-15.02	27.39	3	Vertical	306	2.61	-	28.50	3.09	-
AV	2.4835G	53.56	54.00	-0.44	21.97	3	Vertical	306	2.61	-	28.50	3.09	-

2.4-2.4835GHz_BT-LE(1Mbps)

2480MHz_TX

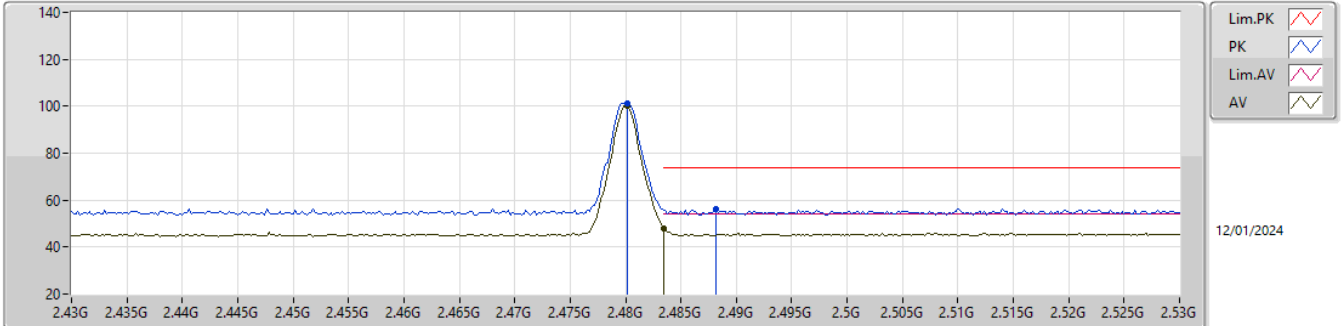

EUTZ_1TX
 Setting 09 09
 01-C-G-5

Type	Freq (Hz)	Level (dBuV/m)	Limit (dBuV/m)	Margin (dB)	Raw (dBuV)	Dist (m)	Condition	Azimuth (°)	Height (m)	Comment	AF (dB)	CL (dB)	PA (dB)
PK	2.4802G	101.39	Inf	-Inf	69.80	3	Horizontal	168	2.69	-	28.50	3.09	-
AV	2.4802G	100.36	Inf	-Inf	68.77	3	Horizontal	168	2.69	-	28.50	3.09	-
PK	2.4882G	56.06	74.00	-17.94	24.46	3	Horizontal	168	2.69	-	28.50	3.10	-
AV	2.4835G	48.09	54.00	-5.91	16.50	3	Horizontal	168	2.69	-	28.50	3.09	-

2.4-2.4835GHz_BT-LE(1Mbps)

2480MHz_TX

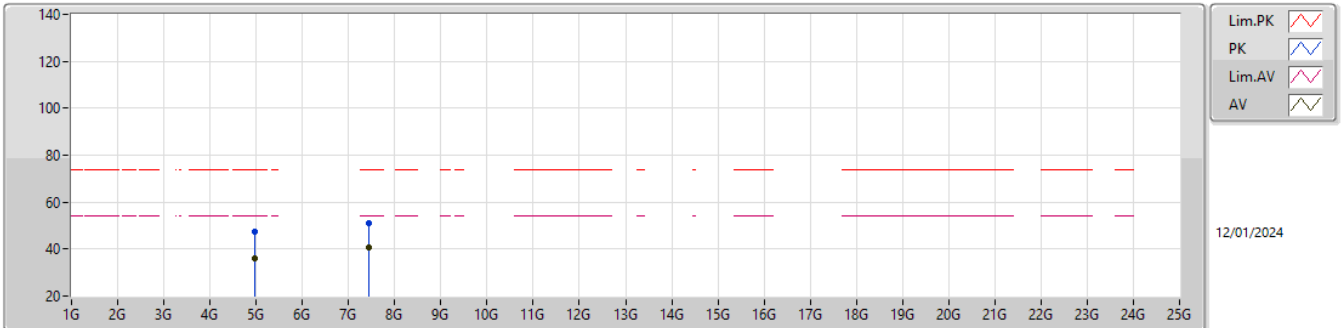

EUT_Z_1TX
Setting 09 09
01-C-G-5

Type	Freq (Hz)	Level (dBuV/m)	Limit (dBuV/m)	Margin (dB)	Raw (dBuV)	Dist (m)	Condition	Azimuth (°)	Height (m)	Comment	AF (dB)	CL (dB)	PA (dB)
PK	4.96014G	47.60	74.00	-26.40	39.73	3	Vertical	277	1.80	-	33.32	5.14	30.59
AV	4.96462G	35.78	54.00	-18.22	27.89	3	Vertical	277	1.80	-	33.33	5.14	30.58
PK	7.44074G	51.15	74.00	-22.85	40.06	3	Vertical	152	1.80	-	36.70	6.58	32.19
AV	7.44212G	40.54	54.00	-13.46	29.45	3	Vertical	152	1.80	-	36.70	6.58	32.19

2.4-2.4835GHz_BT-LE(1Mbps)

2480MHz_TX

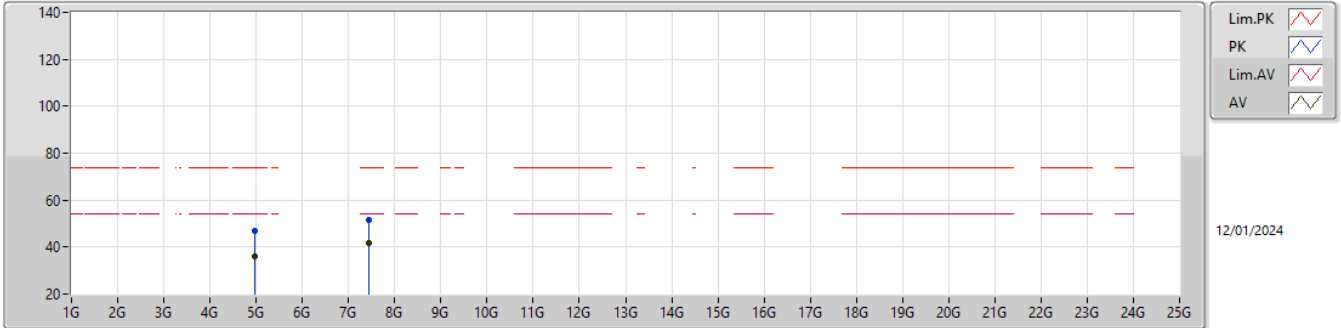

EUTZ_1TX
Setting 09 09
01-C-G-5

Type	Freq (Hz)	Level (dBuV/m)	Limit (dBuV/m)	Margin (dB)	Raw (dBuV)	Dist (m)	Condition	Azimuth (°)	Height (m)	Comment	AF (dB)	CL (dB)	PA (dB)
PK	4.96036G	46.76	74.00	-27.24	38.89	3	Horizontal	0	2.66	-	33.32	5.14	30.59
AV	4.95938G	36.19	54.00	-17.81	28.32	3	Horizontal	0	2.66	-	33.32	5.14	30.59
PK	7.43602G	51.53	74.00	-22.47	40.43	3	Horizontal	271	2.43	-	36.70	6.58	32.18
AV	7.44014G	41.61	54.00	-12.39	30.52	3	Horizontal	271	2.43	-	36.70	6.58	32.19

2.4-2.4835GHz_BT-LE(2Mbps)

2402MHz_TX

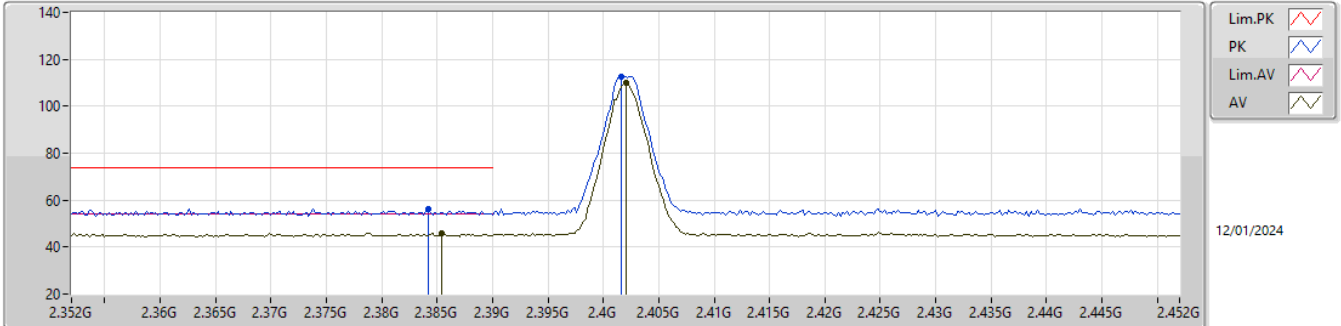

EUTZ_1TX
 Setting 0C 0C
 01-C-G-5

Type	Freq (Hz)	Level (dBuV/m)	Limit (dBuV/m)	Margin (dB)	Raw (dBuV)	Dist (m)	Condition	Azimuth (°)	Height (m)	Comment	AF (dB)	CL (dB)	PA (dB)
PK	2.3842G	56.13	74.00	-17.87	24.68	3	Vertical	285	3.00	-	28.40	3.05	-
AV	2.3854G	45.90	54.00	-8.10	14.45	3	Vertical	285	3.00	-	28.40	3.05	-
PK	2.4016G	112.74	Inf	-Inf	81.28	3	Vertical	285	3.00	-	28.40	3.06	-
AV	2.402G	109.87	Inf	-Inf	78.41	3	Vertical	285	3.00	-	28.40	3.06	-

2.4-2.4835GHz_BT-LE(2Mbps)

2402MHz_TX

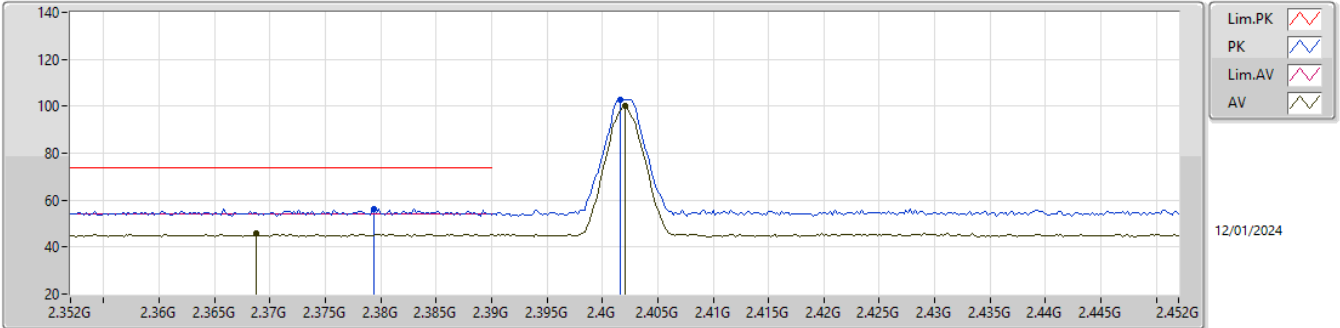

EUTZ_1TX
 Setting 0C 0C
 01-C-G-5

Type	Freq (Hz)	Level (dBuV/m)	Limit (dBuV/m)	Margin (dB)	Raw (dBuV)	Dist (m)	Condition	Azimuth (°)	Height (m)	Comment	AF (dB)	CL (dB)	PA (dB)
PK	2.3794G	56.07	74.00	-17.93	24.63	3	Horizontal	165	2.59	-	28.39	3.05	-
AV	2.3688G	45.83	54.00	-8.17	14.50	3	Horizontal	165	2.59	-	28.29	3.04	-
PK	2.4016G	102.83	Inf	-Inf	71.37	3	Horizontal	165	2.59	-	28.40	3.06	-
AV	2.402G	99.93	Inf	-Inf	68.47	3	Horizontal	165	2.59	-	28.40	3.06	-

2.4-2.4835GHz_BT-LE(2Mbps)

2402MHz_TX

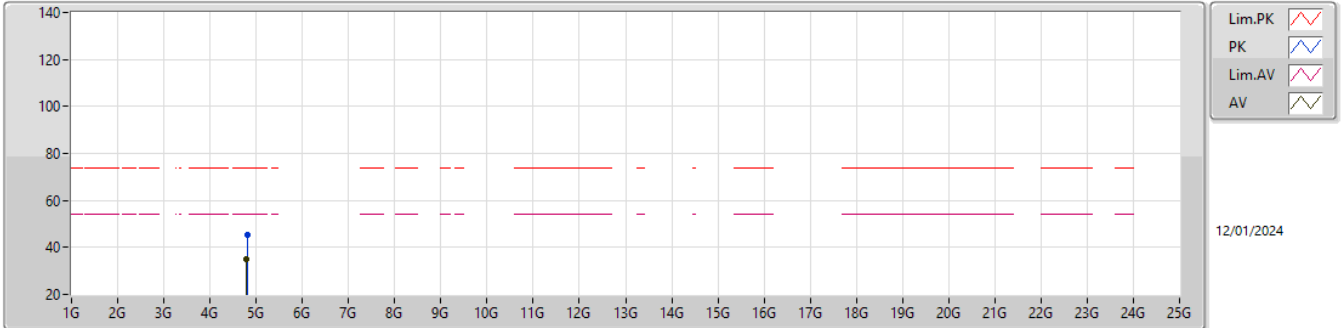

EUT_Z_1TX
 Setting 0C 0C
 01-C-G-5

Type	Freq (Hz)	Level (dBuV/m)	Limit (dBuV/m)	Margin (dB)	Raw (dBuV)	Dist (m)	Condition	Azimuth (°)	Height (m)	Comment	AF (dB)	CL (dB)	PA (dB)
PK	4.80356G	45.48	74.00	-28.52	38.26	3	Vertical	266	1.80	-	32.82	5.09	30.69
AV	4.79596G	34.85	54.00	-19.15	27.66	3	Vertical	266	1.80	-	32.79	5.09	30.69

2.4-2.4835GHz_BT-LE(2Mbps)

2402MHz_TX

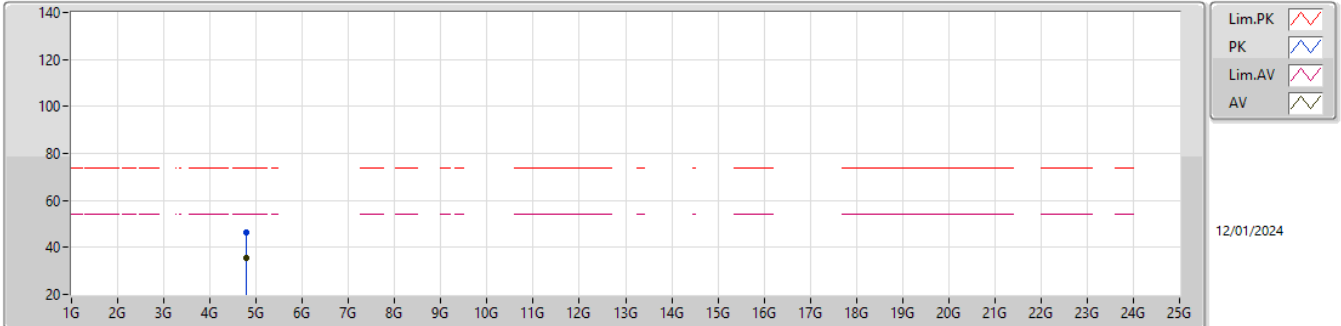

EUTZ_1TX
 Setting 0C 0C
 01-C-G-5

Type	Freq (Hz)	Level (dBuV/m)	Limit (dBuV/m)	Margin (dB)	Raw (dBuV)	Dist (m)	Condition	Azimuth (°)	Height (m)	Comment	AF (dB)	CL (dB)	PA (dB)
PK	4.7972G	46.42	74.00	-27.58	39.23	3	Horizontal	346	1.13	-	32.79	5.09	30.69
AV	4.7972G	35.48	54.00	-18.52	28.28	3	Horizontal	346	1.13	-	32.80	5.09	30.69

2.4-2.4835GHz_BT-LE(2Mbps)

2440MHz_TX

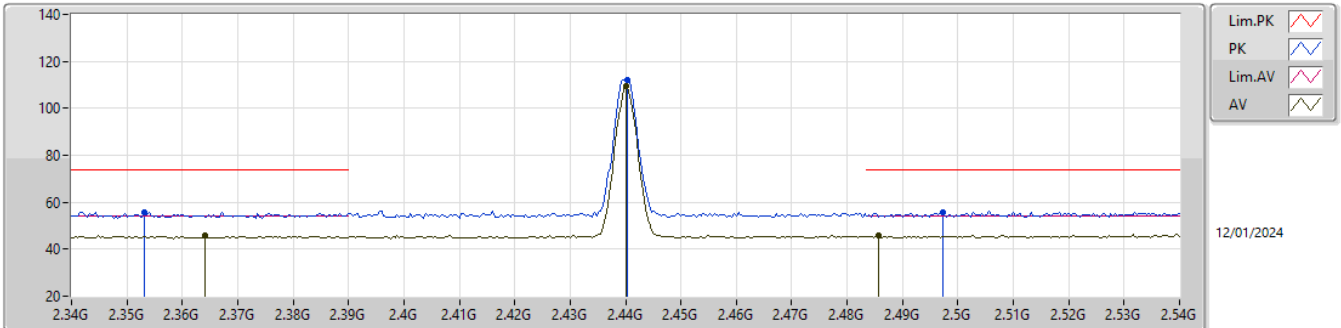

EUTZ_1TX
 Setting 0C 0C
 01-C-G-5

Type	Freq (Hz)	Level (dBuV/m)	Limit (dBuV/m)	Margin (dB)	Raw (dBuV)	Dist (m)	Condition	Azimuth (°)	Height (m)	Comment	AF (dB)	CL (dB)	PA (dB)
PK	2.3532G	55.92	74.00	-18.08	24.68	3	Vertical	303	2.73	-	28.20	3.04	-
AV	2.364G	45.99	54.00	-8.01	14.71	3	Vertical	303	2.73	-	28.24	3.04	-
PK	2.4404G	112.16	Inf	-Inf	80.68	3	Vertical	303	2.73	-	28.40	3.08	-
AV	2.44G	109.30	Inf	-Inf	77.82	3	Vertical	303	2.73	-	28.40	3.08	-
PK	2.4972G	55.56	74.00	-18.44	23.89	3	Vertical	303	2.73	-	28.57	3.10	-
AV	2.4856G	45.81	54.00	-8.19	14.22	3	Vertical	303	2.73	-	28.50	3.09	-

2.4-2.4835GHz_BT-LE(2Mbps)

2440MHz_TX

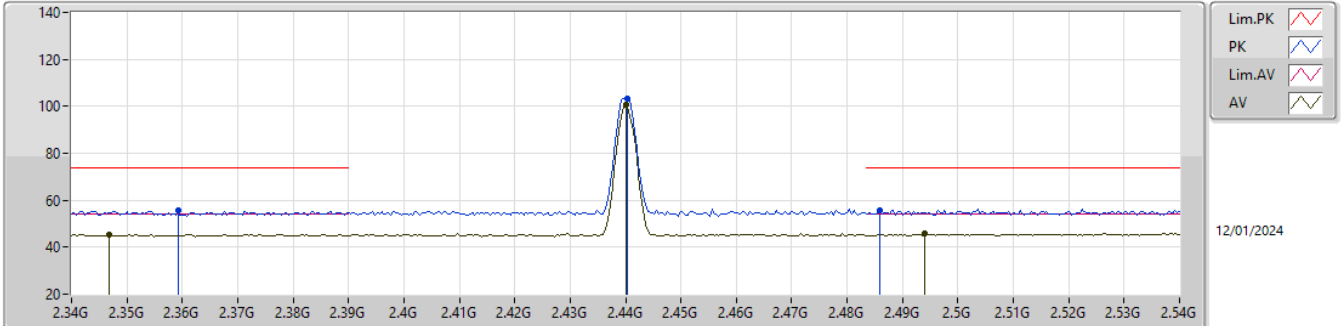

EUTZ_1TX
 Setting 0C 0C
 01-C-G-5

Type	Freq (Hz)	Level (dBuV/m)	Limit (dBuV/m)	Margin (dB)	Raw (dBuV)	Dist (m)	Condition	Azimuth (°)	Height (m)	Comment	AF (dB)	CL (dB)	PA (dB)
PK	2.3592G	55.61	74.00	-18.39	24.37	3	Horizontal	352	1.63	-	28.20	3.04	-
AV	2.3468G	45.56	54.00	-8.44	14.36	3	Horizontal	352	1.63	-	28.17	3.03	-
PK	2.4404G	103.49	Inf	-Inf	72.01	3	Horizontal	352	1.63	-	28.40	3.08	-
AV	2.44G	100.51	Inf	-Inf	69.03	3	Horizontal	352	1.63	-	28.40	3.08	-
PK	2.486G	55.83	74.00	-18.17	24.24	3	Horizontal	352	1.63	-	28.50	3.09	-
AV	2.494G	45.62	54.00	-8.38	13.98	3	Horizontal	352	1.63	-	28.54	3.10	-

2.4-2.4835GHz_BT-LE(2Mbps)

2440MHz_TX

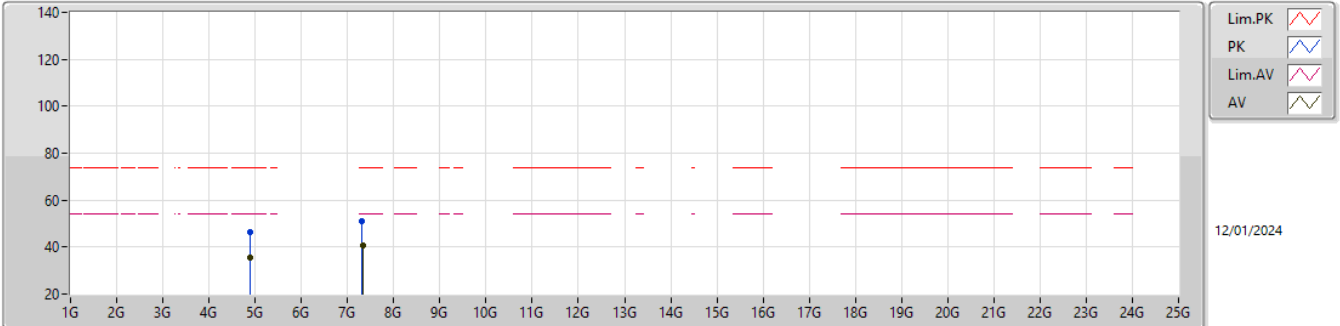

EUTZ_1TX
 Setting 0C 0C
 01-C-G-5

Type	Freq (Hz)	Level (dBuV/m)	Limit (dBuV/m)	Margin (dB)	Raw (dBuV)	Dist (m)	Condition	Azimuth (°)	Height (m)	Comment	AF (dB)	CL (dB)	PA (dB)
PK	4.87952G	46.52	74.00	-27.48	38.89	3	Vertical	321	1.66	-	33.16	5.11	30.64
AV	4.87928G	35.72	54.00	-18.28	28.09	3	Vertical	321	1.66	-	33.16	5.11	30.64
PK	7.31548G	50.94	74.00	-23.06	39.92	3	Vertical	87	2.83	-	36.63	6.51	32.12
AV	7.32348G	40.73	54.00	-13.27	29.68	3	Vertical	87	2.83	-	36.65	6.52	32.12

2.4-2.4835GHz_BT-LE(2Mbps)

2440MHz_TX

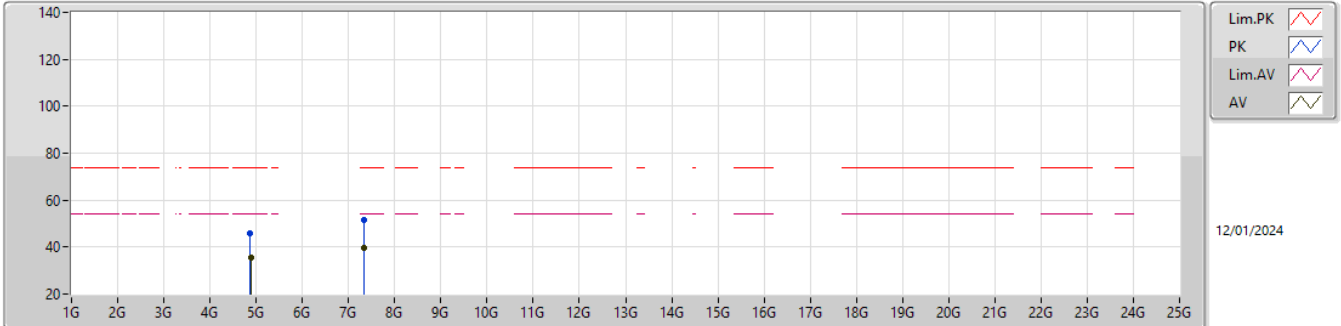

EUTZ_1TX
 Setting 0C 0C
 01-C-G-5

Type	Freq (Hz)	Level (dBuV/m)	Limit (dBuV/m)	Margin (dB)	Raw (dBuV)	Dist (m)	Condition	Azimuth (°)	Height (m)	Comment	AF (dB)	CL (dB)	PA (dB)
PK	4.87456G	46.09	74.00	-27.91	38.47	3	Horizontal	18	1.83	-	33.15	5.11	30.64
AV	4.88984G	35.49	54.00	-18.51	27.82	3	Horizontal	18	1.83	-	33.18	5.12	30.63
PK	7.32996G	51.54	74.00	-22.46	40.48	3	Horizontal	99	1.85	-	36.66	6.52	32.12
AV	7.32864G	39.49	54.00	-14.51	28.43	3	Horizontal	99	1.85	-	36.66	6.52	32.12

2.4-2.4835GHz_BT-LE(2Mbps)

2478MHz_TX

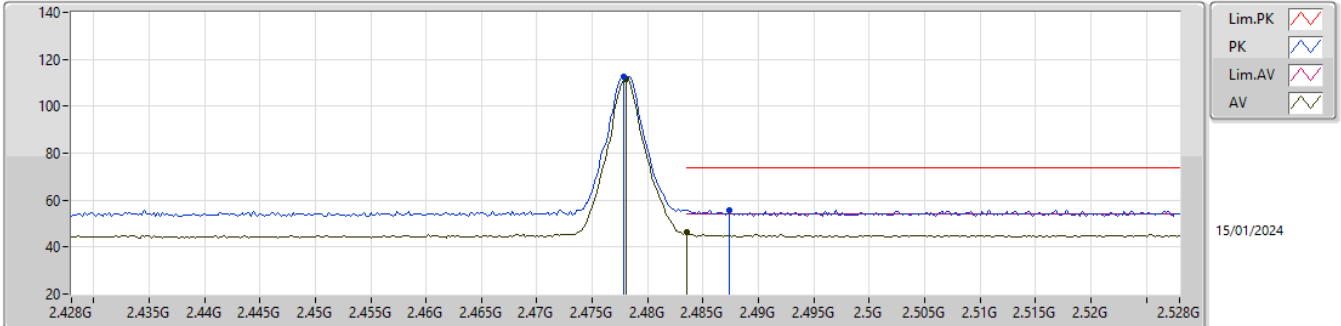

EUTZ_1TX
 Setting 0C 0C
 02-C-V-1

Type	Freq (Hz)	Level (dBuV/m)	Limit (dBuV/m)	Margin (dB)	Raw (dBuV)	Dist (m)	Condition	Azimuth (°)	Height (m)	Comment	AF (dB)	CL (dB)	PA (dB)
PK	2.4778G	112.47	Inf	-Inf	80.88	3	Vertical	132	2.68	-	28.50	3.09	-
AV	2.478G	111.39	Inf	-Inf	79.80	3	Vertical	132	2.68	-	28.50	3.09	-
PK	2.4874G	55.81	74.00	-18.19	24.22	3	Vertical	132	2.68	-	28.50	3.09	-
AV	2.4835G	46.32	54.00	-7.68	14.73	3	Vertical	132	2.68	-	28.50	3.09	-

2.4-2.4835GHz_BT-LE(2Mbps)

2478MHz_TX

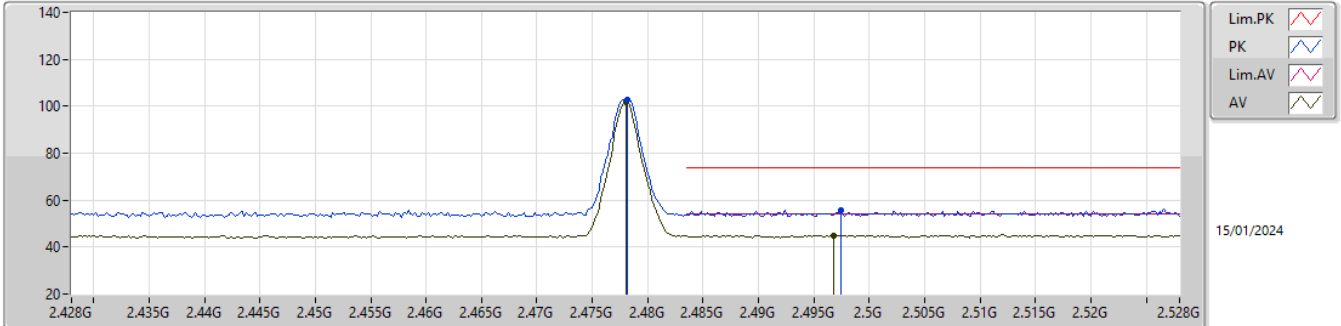

EUTZ_1TX
 Setting 0C 0C
 02-C-V-1

Type	Freq (Hz)	Level (dBuV/m)	Limit (dBuV/m)	Margin (dB)	Raw (dBuV)	Dist (m)	Condition	Azimuth (°)	Height (m)	Comment	AF (dB)	CL (dB)	PA (dB)
PK	2.4782G	102.75	Inf	-Inf	71.16	3	Horizontal	170	3.00	-	28.50	3.09	-
AV	2.478G	101.62	Inf	-Inf	70.03	3	Horizontal	170	3.00	-	28.50	3.09	-
PK	2.4974G	55.69	74.00	-18.31	24.02	3	Horizontal	170	3.00	-	28.57	3.10	-
AV	2.4968G	44.92	54.00	-9.08	13.25	3	Horizontal	170	3.00	-	28.57	3.10	-

2.4-2.4835GHz_BT-LE(2Mbps)

2480MHz_TX

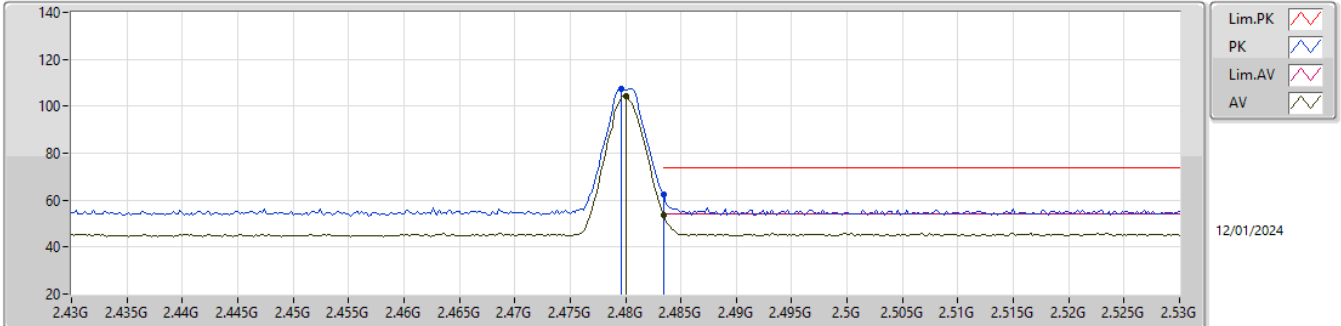

EUTZ_1TX
Setting 06 06
01-C-G-5

Type	Freq (Hz)	Level (dBuV/m)	Limit (dBuV/m)	Margin (dB)	Raw (dBuV)	Dist (m)	Condition	Azimuth (°)	Height (m)	Comment	AF (dB)	CL (dB)	PA (dB)
PK	2.4796G	107.43	Inf	-Inf	75.84	3	Vertical	308	2.60	-	28.50	3.09	-
AV	2.48G	104.53	Inf	-Inf	72.94	3	Vertical	308	2.60	-	28.50	3.09	-
PK	2.4835G	62.47	74.00	-11.53	30.88	3	Vertical	308	2.60	-	28.50	3.09	-
AV	2.4835G	53.64	54.00	-0.36	22.05	3	Vertical	308	2.60	-	28.50	3.09	-

2.4-2.4835GHz_BT-LE(2Mbps)

2480MHz_TX

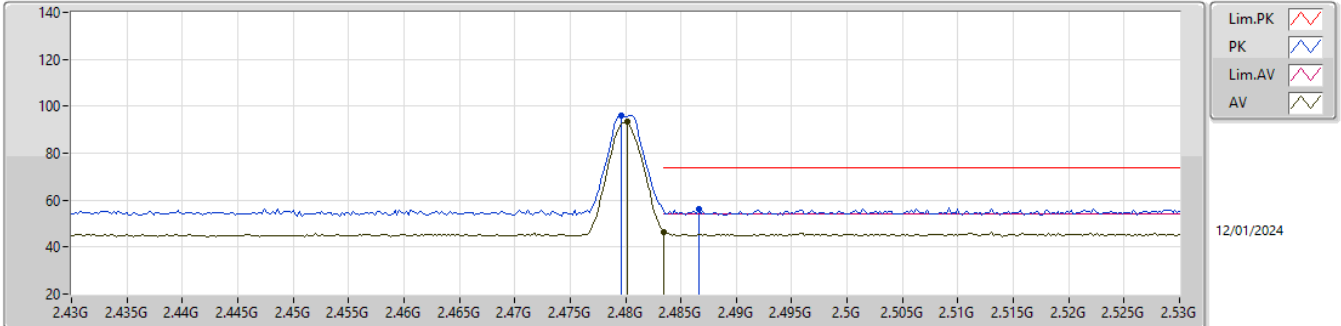

EUTZ_1TX
 Setting 06 06
 01-C-G-5

Type	Freq (Hz)	Level (dBuV/m)	Limit (dBuV/m)	Margin (dB)	Raw (dBuV)	Dist (m)	Condition	Azimuth (°)	Height (m)	Comment	AF (dB)	CL (dB)	PA (dB)
PK	2.4796G	96.20	Inf	-Inf	64.61	3	Horizontal	82	1.80	-	28.50	3.09	-
AV	2.4802G	93.21	Inf	-Inf	61.62	3	Horizontal	82	1.80	-	28.50	3.09	-
PK	2.4866G	55.96	74.00	-18.04	24.37	3	Horizontal	82	1.80	-	28.50	3.09	-
AV	2.4835G	46.37	54.00	-7.63	14.78	3	Horizontal	82	1.80	-	28.50	3.09	-

2.4-2.4835GHz_BT-LE(2Mbps)

2480MHz_TX

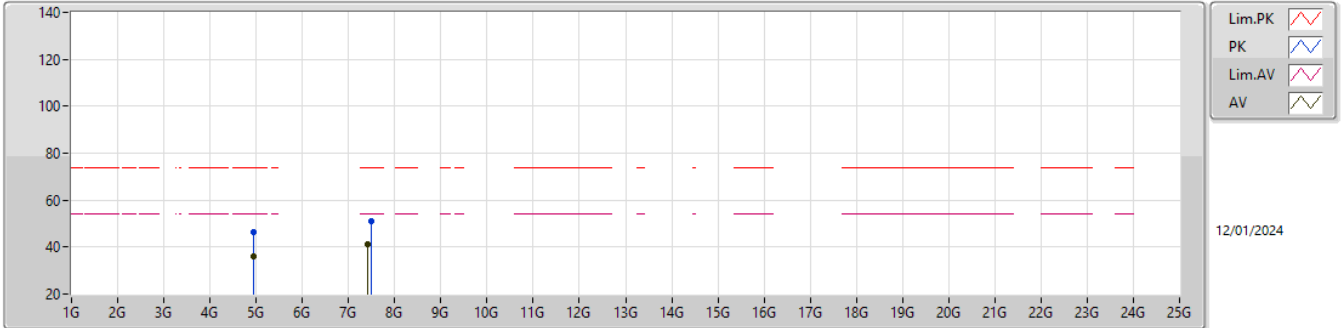

EUT_Z_1TX
Setting 06 06
01-C-G-5

Type	Freq (Hz)	Level (dBuV/m)	Limit (dBuV/m)	Margin (dB)	Raw (dBuV)	Dist (m)	Condition	Azimuth (°)	Height (m)	Comment	AF (dB)	CL (dB)	PA (dB)
PK	4.9446G	46.43	74.00	-27.57	38.61	3	Vertical	307	2.72	-	33.29	5.13	30.60
AV	4.9318G	35.89	54.00	-18.11	28.11	3	Vertical	307	2.72	-	33.26	5.13	30.61
PK	7.4854G	51.15	74.00	-22.85	40.06	3	Vertical	266	1.99	-	36.70	6.60	32.21
AV	7.419G	41.22	54.00	-12.78	30.12	3	Vertical	266	1.99	-	36.70	6.57	32.17

2.4-2.4835GHz_BT-LE(2Mbps)

2480MHz_TX

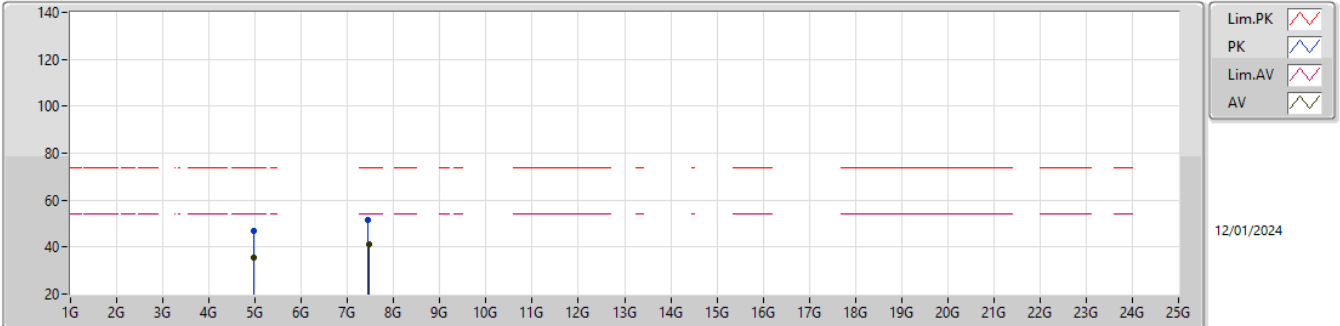

EUT_Z_1TX
Setting 06 06
01-C-G-5

Type	Freq (Hz)	Level (dBuV/m)	Limit (dBuV/m)	Margin (dB)	Raw (dBuV)	Dist (m)	Condition	Azimuth (°)	Height (m)	Comment	AF (dB)	CL (dB)	PA (dB)
PK	4.9618G	46.84	74.00	-27.16	38.97	3	Horizontal	279	1.55	-	33.32	5.14	30.59
AV	4.9606G	35.64	54.00	-18.36	27.77	3	Horizontal	279	1.55	-	33.32	5.14	30.59
PK	7.4446G	51.69	74.00	-22.31	40.60	3	Horizontal	93	2.31	-	36.70	6.58	32.19
AV	7.4752G	41.10	54.00	-12.90	30.01	3	Horizontal	93	2.31	-	36.70	6.60	32.21