



Test Report

FCC Part15 Subpart C & RSS-247 Issue 2

Product Name : Wireless Access Point

Model No. : AP460C

FCC ID : QXO-AP460C

IC : 4141B-AP460C

Applicant : Extreme Networks, Inc

Address : 6480 Via Del Oro, San Jose, CA
95119

Date of Receipt : Oct. 28, 2019

Test Date : Oct. 14, 2019~ Jan. 20, 2020

Issued Date : Mar. 11, 2020

Report No. : 19A2144R-RF-US-P06V01

Report Version : V1.0

The test results presented in this report relate only to the object tested.

The measurement result is considered in conformance with the requirement if it is within the prescribed limit, It is not necessary to account the uncertainty associated with the measurement result, unless the specification, standard or customer have special requirements

This report shall not be reproduced, except in full, without the written approval of the Issuing CB Testing Laboratory

This report is not used for social proof in China (or Mainland China) market.

Test Report Certification

Issued Date: Mar. 11, 2020
Report No. : 19A2144R-RF-US-P06V01



Product Name : Wireless Access Point
 Applicant : Extreme Networks, Inc
 Address : 6480 Via Del Oro, San Jose, CA 95119
 Manufacturer : Extreme Networks, Inc
 Address : 6480 Via Del Oro, San Jose, CA 95119
 Model No. : AP460C
 Brand : Extreme Networks
 FCC ID : QXO-AP460C
 IC : 4141B-AP460C
 EUT Voltage : DC 37~57V
 Test Voltage : AC 120V/60Hz
 Applicable Standard : FCC CFR Title 47 Part 15 Subpart C
 ANSI C63.10:2013;
 KDB 558074 D01v05r02
 KDB 662911 D01 Multiple Transmitter Output v02r01
 RSS-Gen Issue 5 / RSS-247 Issue 2

Test Result : Complied
 Performed Location : DEKRA Testing and Certification (Suzhou) Co., Ltd.
 No.99 Hongye Rd., Suzhou Industrial Park, Suzhou, 215006,
 Jiangsu, China
 TEL: +86-512-6251-5088 / FAX: +86-512-6251-5098
 FCC Designation Number: CN1199
 ISED CAB identifier: CN0040

Documented By : Kitty Li
 (Adm. Specialist: Kitty Li)

Reviewed By : Frank He
 (Technical Supervisor: Frank He)

Approved By : Jack Zhang
 (Engineer Supervisor: Jack Zhang)

TABLE OF CONTENTS

Description	Page
1. General Information.....	6
1.1. EUT Description	6
1.2. Working Frequency of Each Channel:	7
1.3. Antenna information	8
1.4. Mode of Operation.....	9
1.5. Tested System Details	9
1.6. Configuration of Tested System.....	10
1.7. EUT Exercise Software.....	11
2. Technical Test.....	12
2.1. Summary of Test Result.....	12
2.2. Test Frequency configuration:.....	14
2.3. Power vs Data Rate.....	15
2.4. Test Environment.....	17
2.5. Measurement Uncertainty.....	17
3. AC Power Line Conducted Emission.....	18
3.1. Test Equipment.....	18
3.2. Test Setup.....	18
3.3. Limit.....	19
3.4. Test Procedure	19
3.5. Test Result.....	20
4. Emissions in restricted frequency bands	22
4.1. Test Equipment.....	22
4.2. Test Setup.....	23
4.3. Limit.....	24
4.4. Test Procedure	27
4.5. EUT test Axis definition.....	28
4.6. Test Result.....	29
5. Emissions in non-restricted frequency bands	34
5.1. Test Equipment.....	34
5.2. Test Setup.....	35
5.3. Limit.....	36
5.4. Test Procedure	37
5.5. EUT test Axis definition.....	38
5.6. Test Result.....	39
6. Band Edge.....	41
6.1. Test Equipment.....	41
6.2. Test Setup.....	42

6.3.	Limit.....	42
6.4.	Test Procedure	43
6.5.	EUT test definition	44
6.6.	Duty Cycle	45
6.7.	Test Result.....	48
7.	Occupied Bandwidth.....	109
7.1.	Test Equipment.....	109
7.2.	Test Setup.....	109
7.3.	Limit.....	110
7.4.	Test Procedure	110
7.5.	EUT test definition	111
7.6.	Test Result.....	112
8.	Fundamental emission output power	113
8.1.	Test Equipment.....	113
8.2.	Test Setup.....	113
8.3.	Limit.....	114
8.4.	Test Procedure	115
8.5.	EUT test definition	117
8.6.	Test Result.....	118
9.	Power Spectral Density	119
9.1.	Test Equipment.....	119
9.2.	Test Setup.....	119
9.3.	Limit.....	119
9.4.	Test Procedure	120
9.5.	EUT test definition	122
9.6.	Test Result.....	123
10.	Antenna Requirement.....	126
10.1.	Limit.....	126
10.2.	Antenna Connector Construction.....	126

History of This Test Report

REPORT NO.	VERSION	DESCRIPTION	ISSUED DATE
19A2144R-RF-US-P06V01	V1.0	Initial Issued Report	Mar. 11, 2020

1. General Information

1.1. EUT Description

Product Name	Wireless Access Point
Model No.	AP460C
EUT Voltage	DC 37~57V
Frequency Range	For 2.4GHz Band 802.11b/g/n/ax(20MHz): 2412~2462MHz
Channel Number	For 2.4GHz Band 802.11b/g/n/ax(20MHz): 11
Type of Modulation	802.11b: DSSS-DBPSK, DQPSK, CCK 802.11g/n: OFDM-BPSK, QPSK, 16QAM, 64QAM, 256QAM, 1024QAM
Data Rate	802.11b: 1/2/5.5/11 Mbps 802.11g: 6/9/12/18/24/36/48/54 Mbps 802.11n: up to 144.4 Mbps 802.11ax: up to 286 Mbps
Channel Control	Auto

1.2. Working Frequency of Each Channel:

802.11b/g/n/ax Working Frequency of Each Channel:							
Channel	Frequency	Channel	Frequency	Channel	Frequency	Channel	Frequency
01	2412 MHz	02	2417 MHz	03	2422 MHz	04	2427 MHz
05	2432 MHz	06	2437 MHz	07	2442 MHz	08	2447 MHz
09	2452 MHz	10	2457 MHz	11	2462 MHz	N/A	N/A

1.3. Antenna information

AP460C:

Antenna Model No.	N/A					
Antenna Manufacturer	N/A					
Antenna Delivery	<input checked="" type="checkbox"/>	1*TX+1*RX	<input checked="" type="checkbox"/>	2*TX+2*RX	<input type="checkbox"/>	3*TX+3*RX
Antenna Technology	<input checked="" type="checkbox"/>	SISO				
	<input checked="" type="checkbox"/>	MIMO	<input type="checkbox"/>	Basic methodology		
			<input type="checkbox"/>	Sectorized antenna systems		
			<input type="checkbox"/>	Cross-polarized antennas		
			<input type="checkbox"/>	Unequal antenna gains, with equal transmit powers		
			<input checked="" type="checkbox"/>	Spatial Multiplexing		
<input checked="" type="checkbox"/>	Cyclic Delay Diversity (CDD)					
Antenna Type	PIFA					
Antenna Gain(Radio 1)						
Antenna Technology	Ant Gain (dBi)					
Ant 4(Radio 1)	3.74					
Antenna Gain(Radio 2)						
Antenna Technology	Ant Gain (dBi)					
<input checked="" type="checkbox"/>	SISO	<input checked="" type="checkbox"/>	Ant1 (Radio 2)	2.94		
<input checked="" type="checkbox"/>		<input checked="" type="checkbox"/>	Ant2 (Radio 2)	3.24		
<input checked="" type="checkbox"/>	CDD		3.24dBi for Power; 6.25dBi for PSD			
<input checked="" type="checkbox"/>	Beam-forming		6.25dBi for Power; 6.25dBi for PSD			

Note: The device supports 3 radios, radio 1(1*1 2.4GHz & 1*1 5GHz full band); radio 2(2*2 2.4GHz & 2*2 5GHz low band); radio 3(4*4 5GHz full band & 1*1 BLE), and radio 2 & 3 can works with Dual 2.4GHz & 5GHz mode and Dual 5GHz mode. As the 5GHz high band filter is different between two modes, additional Radio 3 5GHz high band mode is tested for compliance.

Dual 2.4GHz & 5GHz mode: Radio 2(2.4GHz 2*2) + Radio 3(5GHz full band 4*4)

Dual 5GHz mode: Radio 2(5GHz low band 2*2) + Radio 3(5GHz high band 4*4)

1.4. Mode of Operation

Test Modes List
Mode 1: Transmit by 802.11b
Mode 2: Transmit by 802.11g
Mode 3: Transmit by 802.11n(20MHz)
Mode 4: Transmit by 802.11ax(20MHz)

Note 1: Regards to the frequency band operation: the lowest, middle and highest frequency channel were selected to perform the test, then shown on this report.

Note 2: For portable device, radiated tests was verified over X, Y, Z axis, and shown the worst case on this report.

1.5. Tested System Details

The types for all equipment, plus descriptions of all cables used in the tested system (including inserted cards) are:

No.	Product	Manufacturer	Model No.	Serial No.	Power Cord
1	Notebook	Lenovo	Think pad x220	SUA0600195	Non-shielded
A	LAN cable	N/A	N/A	N/A	Shielded, 0.5m
B	LAN cable	N/A	N/A	N/A	Shielded, 10m

1.6. Configuration of Tested System

Test setup Diagram- AC Line Conducted Emission Test

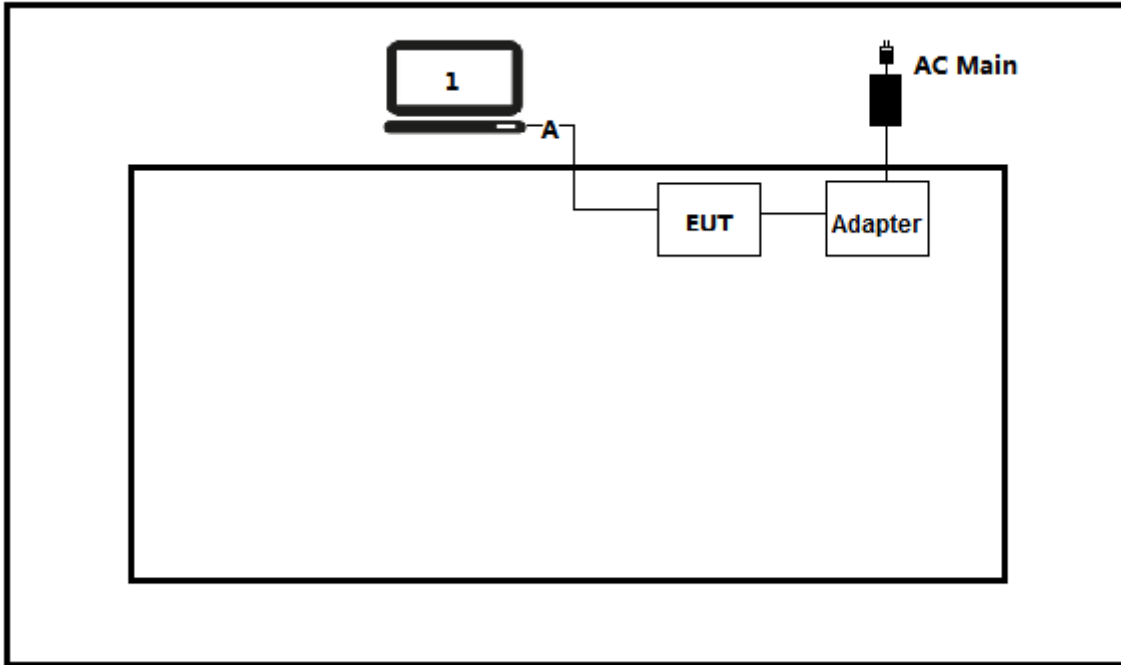

Test setup Diagram- Radiated Emission

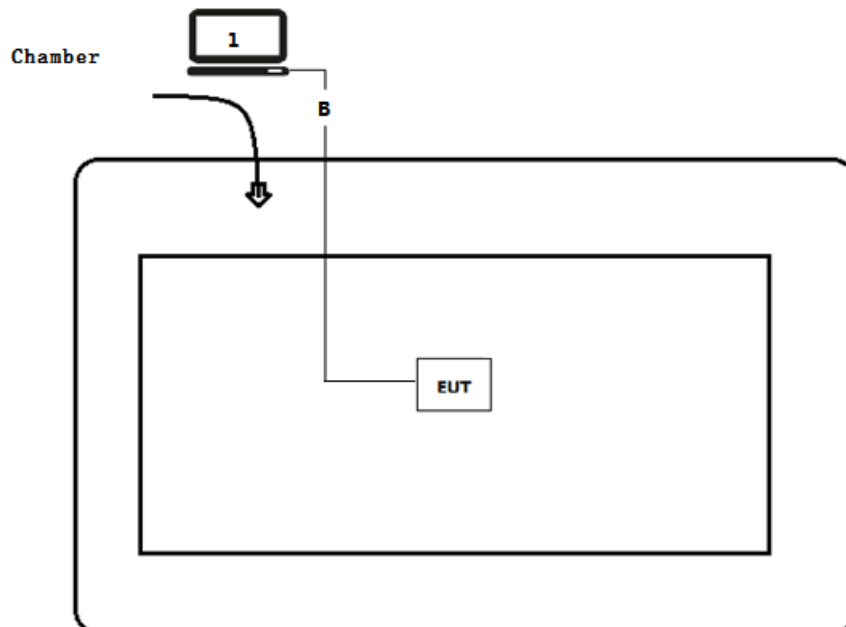

1.7. EUT Exercise Software

1	Setup the EUT and simulators as shown on above.
2	Turn on the power of equipment.
3	Run RF software [MTool], and set the test mode and channel, then press OK to start to continue transmit.

2. Technical Test

2.1. Summary of Test Result

For FCC rule:

Performed Test Item	Normative References	Limit	Result
AC Power Line Conducted Emission	FCC CFR Title 47 Part 15 Subpart C: Section 15.207	FCC 15.207	PASS
Emissions in restricted frequency bands	FCC CFR Title 47 Part 15 Subpart C: Section 15.209	FCC 15.209	PASS
Emissions in non-restricted frequency bands	FCC CFR Title 47 Part 15 Subpart C: Section 15.247(d)	$\geq 30\text{dBc}$	PASS
Radiated Emission Band Edge	FCC CFR Title 47 Part 15 Subpart C: Section 15.205	FCC 15.209	PASS
Occupied Bandwidth	FCC CFR Title 47 Part 15 Subpart C: Section 15.247(a)(2)	$\geq 500\text{kHz}$	PASS
Fundamental emission output power	FCC CFR Title 47 Part 15 Subpart C: Section 15.247(b)(3)	$\leq 30\text{dBm}$	PASS
Power Spectral Density	FCC CFR Title 47 Part 15 Subpart C: Section 15.247(e)	$\leq 8\text{dBm}/3\text{kHz}$	PASS
Antenna Requirement	FCC CFR Title 47 Part 15 Subpart C: Section 15.203	FCC 15.203	PASS

For ISED rule:

Performed Test Item	Normative References	Limit	Result
AC Power Line Conducted Emission	RSS-Gen Issue 5 Section 8.8	RSS-Gen	N/A
Emissions in restricted frequency bands	RSS-Gen Issue 5 Section 8.9	RSS-Gen	PASS
Emissions in non-restricted frequency bands	RSS-247 Issue 2 Section 5.5	$\geq 30\text{dBc}$	PASS
Radiated Emission Band Edge	RSS-Gen Issue 5 Section 8.10	RSS-247	PASS
Occupied Bandwidth	RSS-Gen Issue 5 Section 6.7 RSS-247 Issue 2 Section 5.2(a)	Within Band $\geq 500\text{kHz}$	PASS
Fundamental emission output power	RSS-247 Issue 2 Section 5.4(d)	$\leq 30\text{dBm}$	PASS
Power Spectral Density	RSS-247 Issue 2 Section 5.2(b)	$\leq 8\text{dBm}/3\text{kHz}$	PASS
Antenna Requirement	RSS-Gen Issue 5 Section 6.8	RSS-Gen Issue 5	PASS

2.2. Test Frequency configuration:

Modulation Mode	Channel	Frequency	Channel	Frequency	Channel	Frequency
802.11b	01	2412 MHz	06	2437MHz	11	2462MHz
802.11g	01	2412 MHz	06	2437MHz	11	2462MHz
802.11n(20MHz)	01	2412 MHz	06	2437MHz	11	2462MHz
802.11ax(20MHz)	01	2412 MHz	06	2437MHz	11	2462MHz

2.3. Power vs Data Rate

MCS Index for 802.11n	Spatial Streams (Note1)	Data Rate (Mbps)			
		802.11b	802.11g	20MHz Bandwidth	
				800ns GI	400ns GI
0	1	1	6	6.5	7.2
1	1	2	9	13.0	14.4
2	1	5.5	12	19.5	21.7
3	1	11	18	26.0	28.9
4	1	---	24	39.0	43.3
5	1	---	36	52.0	57.8
6	1	---	48	58.5	65.0
7	1	---	54	65.0	72.2
8	2	---	---	13.0	14.4
9	2	---	---	26.0	28.9
10	2	---	---	39.0	43.3
11	2	---	---	52.0	57.8
12	2	---	---	78.0	86.7
13	2	---	---	104.0	115.6
14	2	---	---	117.0	130.0
15	2	---	---	130.0	144.0

Note 1: The EUT supports all data rate above. The blue form is the maximum power data rate

Note 2: The EUT has two spatial Streams

MCS Index	Spatial Streams (Note1)	Modulation type	Coding rate	Data Rate(Mb/s)	
				20MHz	
				Guard Interval	
				1600 ns GI	800 ns GI
0	1	BPSK	1/2	8	8
1	1	QPSK	1/2	16	17
2	1	QPSK	3/4	24	26
3	1	16-QAM	1/2	33	34
4	1	16-QAM	3/4	49	52
5	1	64-QAM	2/3	65	69
6	1	64-QAM	3/4	73	77
7	1	64-QAM	5/6	81	86
8	1	256-QAM	3/4	98	103
9	1	256-QAM	5/6	108	115
10	1	1024-QAM	3/4	122	129
11	1	1024-QAM	5/6	135	143
12	2	BPSK	1/2	16	16
13	2	QPSK	1/2	32	34
14	2	QPSK	3/4	48	52
15	2	16-QAM	1/2	66	68
16	2	16-QAM	3/4	98	104
17	2	64-QAM	2/3	130	138
18	2	64-QAM	3/4	146	154
19	2	64-QAM	5/6	162	172
20	2	256-QAM	3/4	196	206
21	2	256-QAM	5/6	216	230
22	2	1024-QAM	3/4	244	258
23	2	1024-QAM	5/6	270	286

Note 1: The EUT supports all data rate above. The blue form is the maximum power data rate

Note 2: The EUT has two spatial Streams

2.4. Test Environment

Items	Required (IEC 68-1)	Actual
Temperature (°C)	15-35	21
Humidity (%RH)	25-75	50
Barometric pressure (mbar)	860-1060	950-1000

2.5. Measurement Uncertainty

Test Items	Uncertainty
AC Power Line Conducted Emission	$\pm 2.02\text{dB}$
Radiated Emission	Below 1GHz $\pm 3.8\text{ dB}$
	Above 1GHz $\pm 3.9\text{ dB}$
RF Antenna Port Conducted Emission	$\pm 1.27\text{dB}$
Radiated Emission Band Edge	$\pm 3.9\text{dB}$
Occupied Bandwidth	$\pm 1\text{kHz}$
Power Spectral Density	$\pm 1.27\text{dB}$

3. AC Power Line Conducted Emission

3.1. Test Equipment

AC Power Line Conducted Emission / TR-1					
Instrument	Manufacturer	Type No.	Serial No.	Cal. Date	Cal. Due Date
EMI Test Receiver	R&S	ESCI	100726	2019.03.29	2020.03.28
Two-Line V-Network	R&S	ENV216	100043	2019.03.29	2020.03.28
Two-Line V-Network	R&S	ENV216	100044	2019.09.17	2020.09.16
50ohm Coaxial Switch	Anritsu	MP59B	6200464462	2020.03.02	2021.03.01
50ohm Termination	SHX	TF2	07081401	2019.09.17	2020.09.16
Temperature/Humidity Meter	zhichen	ZC1-2	TR1-TH	2020.01.04	2021.01.03

Note: All equipment are calibrated with traceable calibrations. Each calibration is traceable to the national or international standards.

3.2. Test Setup

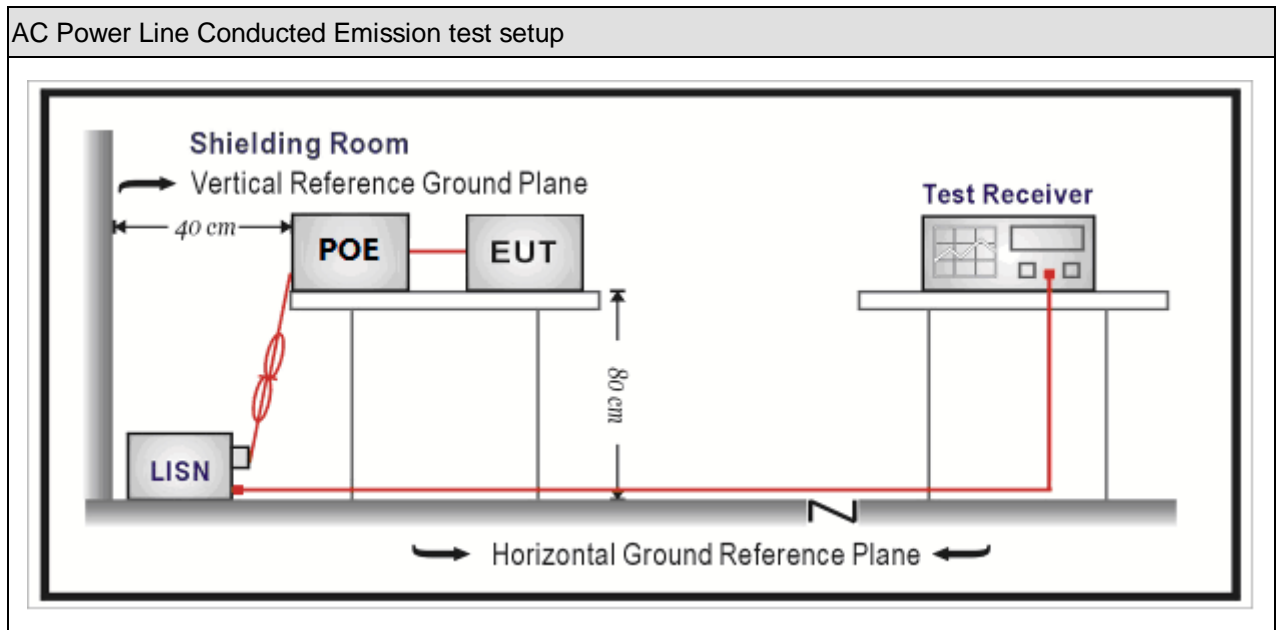

3.3. Limit

Frequency of Emission (MHz)	Conducted Limit	
	Quasi-peak (dB μ V)	Average (dB μ V)
0.15-0.5	66 to 56	56 to 46
0.5-5	56	46
5-30	60	50

Note 1: The lower limit shall apply at the transition frequencies.

Note 2: The limit decreases linearly with the logarithm of the frequency in the range 0.15 MHz to 0.5 MHz.

3.4. Test Procedure

Test Method			
	References Rule	Chapter	Item
<input checked="" type="checkbox"/>	ANSI C63.10-2013	6.2	Standard test method for ac power-line conducted emissions from unlicensed wireless devices

3.5. Test Result

Engineer: Lynee	
Site: TR1	Time: 2019/11/20
Limit: FCC_Part15.207_CE_AC Power	Margin: 0
Probe: ENV216_101189(0.009-30MHz)	Polarity: Line
EUT: Wireless Access Point	Power: AC 120V/60Hz
Note: Simultaneous transmission with 2.4G WIFI + 5G WIFI + BLE	

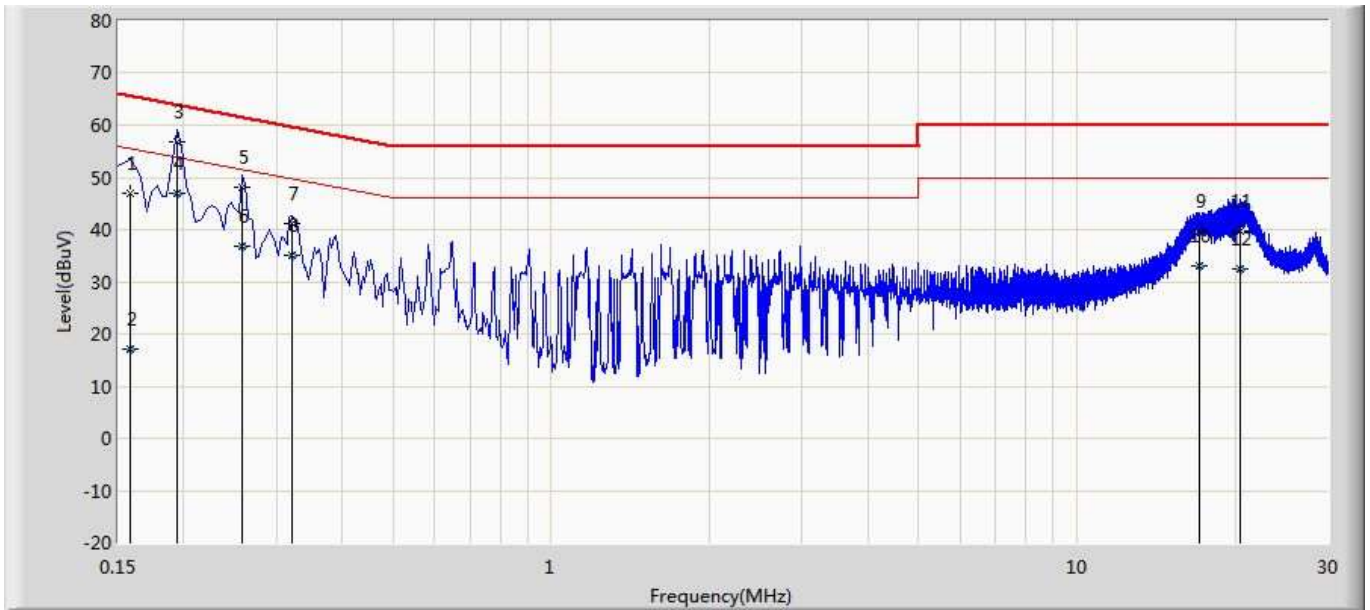

No	Mark	Frequency (MHz)	Measure Level (dBuV)	Reading Level (dBuV)	Over Limit (dB)	Limit (dBuV)	Probe (dB)	Cable (dB)	Amp (dB)	Type
1		0.158	46.959	37.078	-18.610	65.568	9.852	0.029	0.000	QP
2		0.158	17.234	7.354	-38.334	55.568	9.852	0.029	0.000	AV
3		0.194	56.667	46.780	-7.197	63.864	9.859	0.028	0.000	QP
4	*	0.194	46.984	37.097	-6.880	53.864	9.859	0.028	0.000	AV
5		0.258	48.154	38.260	-13.341	61.496	9.862	0.032	0.000	QP
6		0.258	36.875	26.981	-14.620	51.496	9.862	0.032	0.000	AV
7		0.322	41.253	31.354	-18.402	59.655	9.864	0.035	0.000	QP
8		0.322	35.092	25.193	-14.563	49.655	9.864	0.035	0.000	AV
9		17.030	39.722	29.517	-20.278	60.000	9.940	0.265	0.000	QP
10		17.030	33.072	22.866	-16.928	50.000	9.940	0.265	0.000	AV
11		20.442	39.728	29.432	-20.272	60.000	10.004	0.292	0.000	QP
12		20.442	32.568	22.272	-17.432	50.000	10.004	0.292	0.000	AV

Engineer: Lynee	
Site: TR1	Time: 2019/11/20
Limit: FCC_Part15.207_CE_AC Power	Margin: 0
Probe: ENV216_101189(0.009-30MHz)	Polarity: Neutral
EUT: Wireless Access Point	Power: AC 120V/60Hz
Note: Simultaneous transmission with 2.4G WIFI + 5G WIFI + BLE	

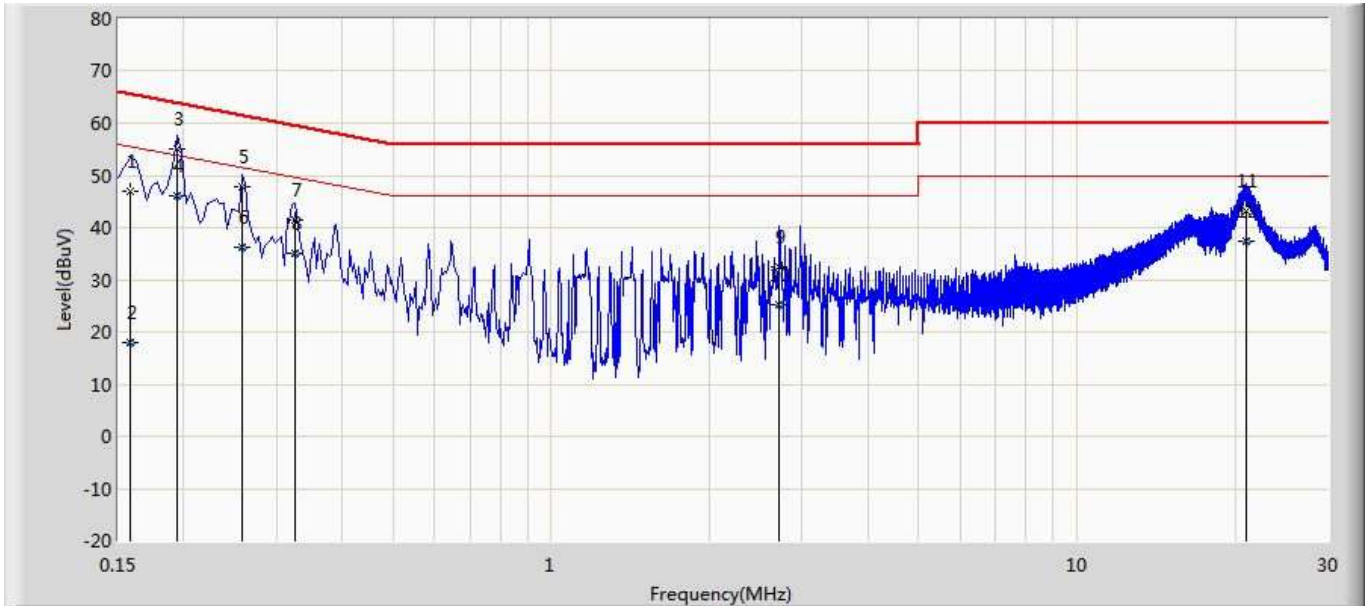

No	Mark	Frequency (MHz)	Measure Level (dBuV)	Reading Level (dBuV)	Over Limit (dB)	Limit (dBuV)	Probe (dB)	Cable (dB)	Amp (dB)	Type
1		0.158	47.009	37.138	-18.559	65.568	9.842	0.029	0.000	QP
2		0.158	17.936	8.065	-37.633	55.568	9.842	0.029	0.000	AV
3		0.194	55.166	45.289	-8.698	63.864	9.849	0.028	0.000	QP
4	*	0.194	46.078	36.201	-7.785	53.864	9.849	0.028	0.000	AV
5		0.258	47.853	37.969	-13.642	61.496	9.852	0.032	0.000	QP
6		0.258	36.279	26.395	-15.216	51.496	9.852	0.032	0.000	AV
7		0.326	41.442	31.552	-18.111	59.552	9.855	0.035	0.000	QP
8		0.326	35.044	25.154	-14.509	49.552	9.855	0.035	0.000	AV
9		2.718	32.475	22.723	-23.525	56.000	9.649	0.103	0.000	QP
10		2.718	25.261	15.509	-20.739	46.000	9.649	0.103	0.000	AV
11		20.962	43.255	33.313	-16.745	60.000	9.646	0.296	0.000	QP
12		20.962	37.289	27.347	-12.711	50.000	9.646	0.296	0.000	AV

Note:

1. " * ", means this data is the worst emission level.
2. Measurement Level = Reading Level + Factor(Probe+Cable-Amp).

4. Emissions in restricted frequency bands

4.1. Test Equipment

Radiated Emission(Below 1GHz) / AC-2					
Instrument	Manufacturer	Type No.	Serial No.	Cal. Date	Cal. Due Date
EMI Test Receiver	R&S	ESCI	100573	2019.03.29	2020.03.28
Loop Antenna	R&S	HFH2-Z2	833799/003	2019.11.16	2020.11.15
Bilog Antenna	Teseq GmbH	CBL6112D	27611	2019.10.16	2020.10.15
Coaxial Cable	Huber+Suhner	SUCOFLEX 106	AC2-C	2020.03.02	2021.03.01
Temperature/Humidity Meter	Zhichen	ZC1-2	AC2-TH	2020.01.04	2021.01.03

Note: All equipment are calibrated with traceable calibrations. Each calibration is traceable to the national or international standards.

Radiated Emission(Above 1GHz) / AC-5					
Instrument	Manufacturer	Type No.	Serial No.	Cal. Date	Cal. Due Date
Spectrum Analyzer	Agilent	E4446A	MY45300103	2020.01.04	2021.01.03
Preamplifier	Miteq	NSP1800-25	1364185	2019.05.06	2020.05.05
Preamplifier	QuieTek	AP-040G	CHM-0906001	2019.05.06	2020.05.05
DRG Horn	ETS-Lindgren	3117	00123988	2020.01.22	2021.01.21
Broad-Band Horn Antenna	Schwarzbeck	BBHA9170	294	2019.11.25	2020.11.24
Coaxial Cable	Huber+Suhner	SUCOFLEX 106	AC5-C1	2020.03.02	2021.03.01
Coaxial Cable	Huber+Suhner	SUCOFLEX 106	AC5-C2	2020.03.02	2021.03.01
Coaxial Cable	Huber+Suhner	SUCOFLEX 102	AC5-C3	2020.03.02	2021.03.01
EMI Receiver	Agilent	N9038A	MY51210196	2019.06.10	2020.06.09
Temperature/Humidity Meter	Zhichen	ZC1-2	AC5-TH	2020.01.04	2021.01.03

Note: All equipment are calibrated with traceable calibrations. Each calibration is traceable to the national or international standards.

4.2. Test Setup

Below 30MHz Test Setup:

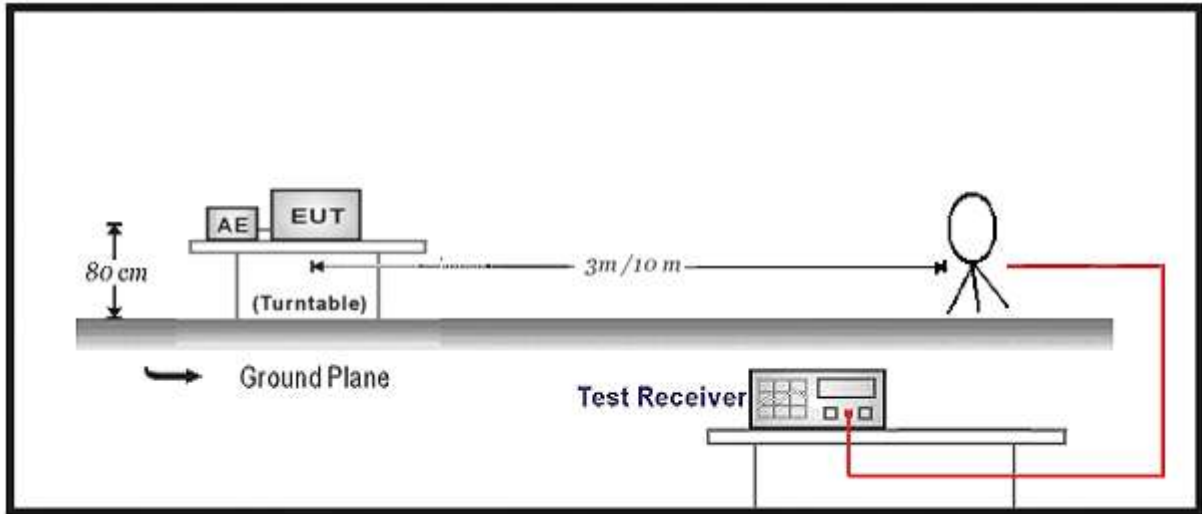

30MHz-1GHz Test Setup:

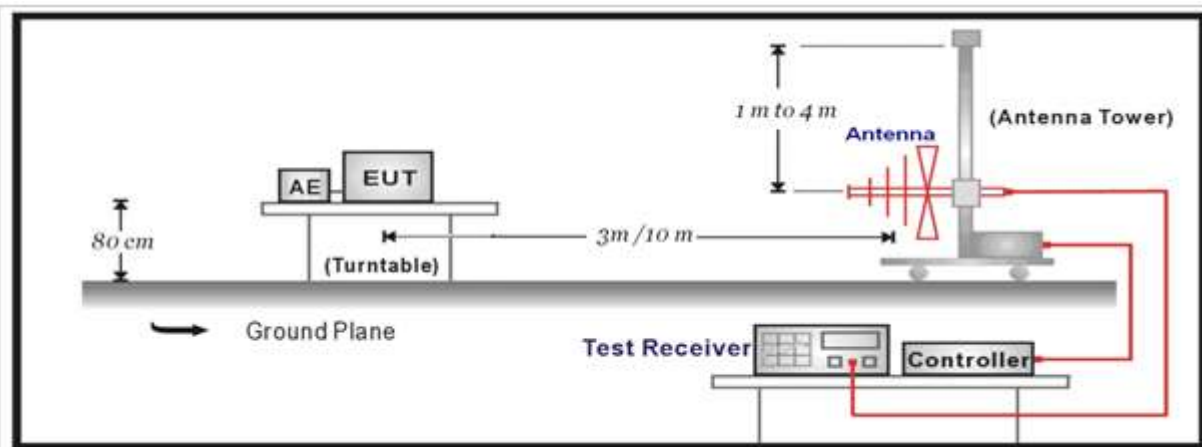

Above 1GHz Test Setup:

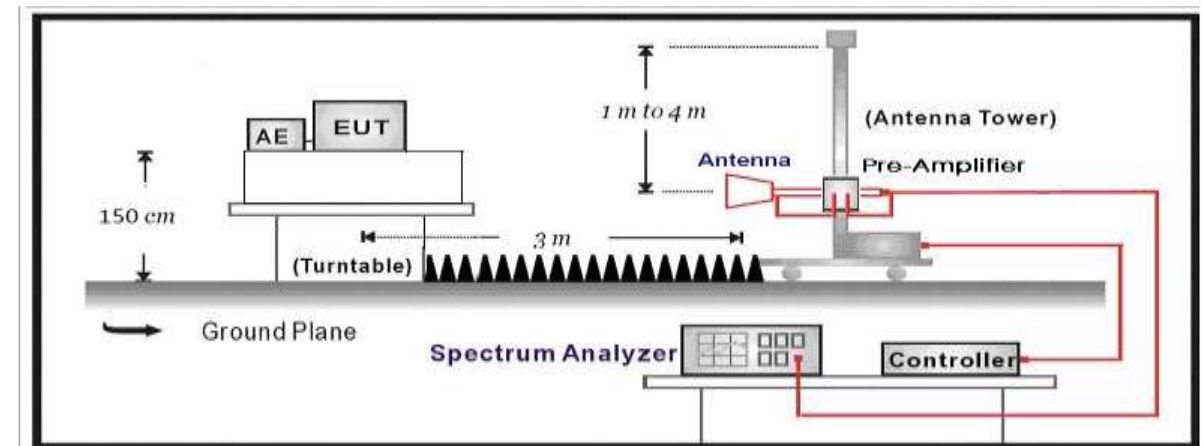

4.3. Limit

For FCC

Restricted Bands of operation			
Frequency (MHz)	Frequency (MHz)	Frequency (MHz)	Frequency (GHz)
0.090 – 0.110	16.42 – 16.423	399.9 – 410	4.5 – 5.15
0.495 – 0.505	16.69475 – 16.69525	608 – 614	5.35 – 5.46
2.1735 – 2.1905	16.80425 – 16.80475	960 – 1240	7.25 – 7.75
4.125 – 4.128	25.5 – 25.67	1300 – 1427	8.025 – 8.5
4.17725 – 4.17775	37.5 – 38.25	1435 – 1626.5	9.0 – 9.2
4.20725 – 4.20775	73 – 74.6	1645.5 – 1646.5	9.3 – 9.5
6.215 – 6.218	74.8 – 75.2	1660 – 1710	10.6 – 12.7
6.26775 – 6.26825	108 – 121.94	1718.8 – 1722.2	13.25 – 13.4
6.31175 – 6.31225	123 – 138	2200 – 2300	14.47 – 14.5
8.291 – 8.294	149.9 – 150.05	2310 – 2390	15.35 – 16.2
8.362 – 8.366	156.52475 – 156.52525	2483.5 – 2500	17.7 – 21.4
8.37625 – 8.38675	156.7 – 156.9	2690 – 2900	22.01 – 23.12
8.81425 – 8.81475	162.0125 – 167.17	3260 – 3267	23.6 – 24.0
12.29 – 12.293	167.72 – 173.2	3332 – 3339	31.2 – 31.8
12.51975 – 12.52025	240 – 285	3345.8 – 3358	36.43 – 36.5
12.57675 – 12.57725	322 – 335.4	3600 – 4400	
13.36 – 13.41			

For ISED:

MHz	MHz	GHz
0.090 - 0.110	149.9 - 150.05	9.0 - 9.2
0.495 - 0.505	156.52475 - 156.52525	9.3 - 9.5
2.1735 - 2.1905	156.7 - 156.9	10.6 - 12.7
3.020 - 3.026	162.0125 - 167.17	13.25 - 13.4
4.125 - 4.128	167.72 - 173.2	14.47 - 14.5
4.17725 - 4.17775	240 - 285	15.35 - 16.2
4.20725 - 4.20775	322 - 335.4	17.7 - 21.4
5.677 - 5.683	399.9 - 410	22.01 - 23.12
6.215 - 6.218	608 - 614	23.6 - 24.0
6.26775 - 6.26825	960 - 1427	31.2 - 31.8
6.31175 - 6.31225	1435 - 1626.5	36.43 - 36.5
8.291 - 8.294	1645.5 - 1646.5	Above 38.6
8.362 - 8.366	1660 - 1710	
8.37625 - 8.38675	1718.8 - 1722.2	
8.41425 - 8.41475	2200 - 2300	
12.29 - 12.293	2310 - 2390	
12.51975 - 12.52025	2483.5 - 2500	
12.57675 - 12.57725	2655 - 2900	
13.36 - 13.41	3260 - 3267	
16.42 - 16.423	3332 - 3339	
16.69475 - 16.69525	3345.8 - 3358	
16.80425 - 16.80475	3500 - 4400	
25.5 - 25.67	4500 - 5150	
37.5 - 38.25	5350 - 5460	
73 - 74.6	7250 - 7750	
74.8 - 75.2	8025 - 8500	
108 - 138		

Restricted Band Emissions Limit			
Frequency (MHz)	Field strength (μ V/m)	Field strength (dB μ V/m)	Measurement distance (m)
0.009 - 0.49	2400/F(kHz)	48.5 – 13.8	300 _(Note 1)
0.49 - 1.705	24000/F(kHz)	33.8 - 23	30 _(Note 1)
1.705 - 30	30	29.5	30 _(Note 1)
30 - 88	100	40	3 _(Note 2)
88 - 216	150	43.5	3 _(Note 2)
216 - 960	200	46	3 _(Note 2)
Above 960	500	54	3 _(Note 2)





Note 1: At frequencies below 30 MHz, measurements may be performed at a distance closer than that specified in the regulations; however, an attempt should be made to avoid making measurements in the near field. Pending the development of an appropriate measurement procedure for measurements performed below 30 MHz, when performing measurements at a closer distance than specified, the results shall be extrapolated to the specified distance by either making measurements at a minimum of two distances on at least one radial to determine the proper extrapolation factor or by using the square of an inverse linear distance extrapolation factor (40 dB/decade).

Note 2: At frequencies at or above 30 MHz, measurements may be performed at a distance other than what is specified provided: measurements are not made in the near field except where it can be shown that near field measurements are appropriate due to the characteristics of the device; and it can be demonstrated that the signal levels needed to be measured at the distance employed can be detected by the measurement equipment. Measurements shall not be performed at a distance greater than 30 meters unless it can be further demonstrated that measurements at a distance of 30 meters or less are impractical. When performing measurements at a distance other than that specified, the results shall be extrapolated to the specified distance using an extrapolation factor of 20 dB/decade (inverse linear-distance for field strength measurements; inverse-linear-distance-squared for power density measurements).

4.4. Test Procedure

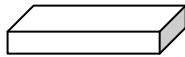
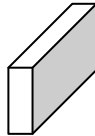
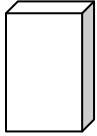
Test Method			
	References Rule	Chapter	Description
<input type="checkbox"/>	ANSI C63.10	11.11	Emissions in non-restricted frequency bands
	<input type="checkbox"/> ANSI C63.10	11.11.2	Reference level measurement
	<input type="checkbox"/> ANSI C63.10	11.11.3	Emission level measurement
<input checked="" type="checkbox"/>	ANSI C63.10	11.12	Emissions in restricted frequency bands
	<input checked="" type="checkbox"/> ANSI C63.10	11.12.1	Radiated emission measurements
	<input checked="" type="checkbox"/> ANSI C63.10	11.12.2.7	Radiated spurious emission test
	<input checked="" type="checkbox"/> ANSI C63.10	6.4	Radiated emissions from unlicensed wireless devices below 30 MHz
	<input checked="" type="checkbox"/> ANSI C63.10	6.5	Radiated emissions from unlicensed wireless devices in the frequency range of 30 MHz to 1000 MHz
	<input checked="" type="checkbox"/> ANSI C63.10	6.6	Radiated emissions from unlicensed wireless devices above 1 GHz
<input type="checkbox"/>	ANSI C63.10	11.12.2	Antenna-port conducted measurements
	<input type="checkbox"/> ANSI C63.10	11.12.2.3	Quasi-peak measurement procedure
	<input type="checkbox"/> ANSI C63.10	11.12.2.4	Peak power measurement procedure
	<input type="checkbox"/> ANSI C63.10	11.12.2.5	Average power measurement procedures
	<input type="checkbox"/> ANSI C63.10	11.12.2.5.1	Trace averaging with continuous EUT transmission at full power
	<input type="checkbox"/> ANSI C63.10	11.12.2.5.2	Trace averaging across ON and OFF times of the EUT transmissions followed by duty cycle correction
	<input type="checkbox"/> ANSI C63.10	11.12.2.5.3	Reduced VBW averaging across ON and OFF times of the EUT transmissions with max hold

4.5. EUT test Axis definition

Item	Emissions in restricted frequency bands			
Device Category	<input type="checkbox"/>	Fixed point-to-point		
	<input type="checkbox"/>	Emit multiple directional beams, simultaneously or sequentially		
	<input checked="" type="checkbox"/>	Other cases		
Test mode	Mode 1~4			
Test method	<input checked="" type="checkbox"/>	Radiated		
		X Axis	Y Axis	Z Axis
				
		Worst Axis <input checked="" type="checkbox"/>	Worst Axis <input type="checkbox"/>	Worst Axis <input type="checkbox"/>
	<input type="checkbox"/>	Conducted		
	<input type="checkbox"/>	Chain 1		
				
	<input type="checkbox"/>	Chain 1	Chain 2	
				
	<input type="checkbox"/>	Chain 1	Chain 2	Chain 3
				

4.6. Test Result

Pass.

Note: 1. Measure Level = Reading Level + Factor.

2. The test frequency range, 9kHz~30MHz, 18GHz~25GHz, both of the worst case are at least 6dB below the limits, therefore no data appear in the report.

3. This limit applies for using average detector, if the test result on peak is lower than average limit, then average measurement needn't be performed.

4. As the radiated emission was performed, so conducted emission was not tested.

5. The data was too large so was showed in below attached files.

Appendix 1: 2.4GHz Radiated spurious emission

The worst case of Radiated Emission below 1GHz:

Engineer: Lacey	
Site: AC3	Time: 2019/11/21
Limit: FCC_Part15.209_RE(3m)	Margin: 0
Probe: AC3_3m (30-1000MHz)	Polarity: Horizontal
EUT: Wireless Access Point	Power: AC 120V/60Hz
Note: Simultaneous transmission with 2.4G WIFI +5G WIFI + BLE	

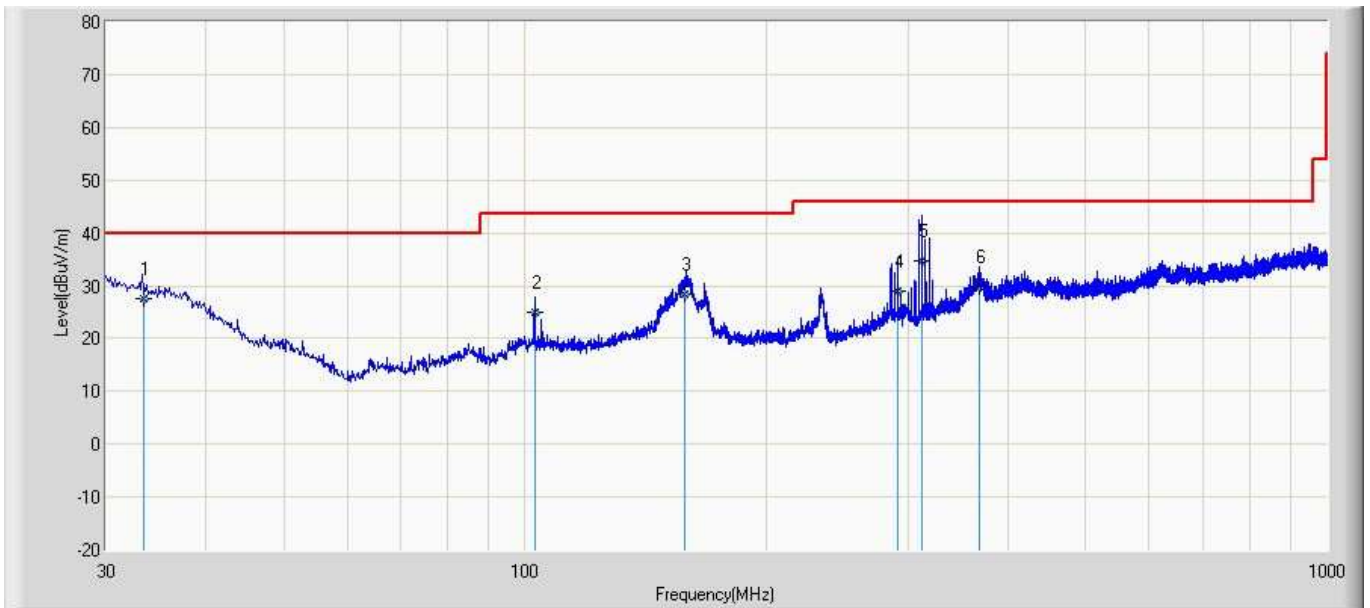

No	Mark	Frequency (MHz)	Measure Level (dBuV/m)	Reading Level (dBuV)	Over Limit (dB)	Limit (dBuV/m)	Probe (dB/m)	Cable (dB)	Amp (dB)	Ant Pos (cm)	Table Pos (deg)	Type
1		33.469	27.540	1.400	-12.460	40.000	19.664	6.476	0.000	100	144	QP
2		102.864	25.116	8.600	-18.384	43.500	9.649	6.868	0.000	200	203	QP
3		158.355	28.520	11.200	-14.980	43.500	10.204	7.115	0.000	100	139	QP
4		291.360	29.091	8.600	-16.909	46.000	12.903	7.589	0.000	100	214	QP
5	*	312.632	34.722	13.600	-11.278	46.000	13.468	7.654	0.000	200	125	QP
6		368.135	29.855	6.100	-16.145	46.000	15.937	7.818	0.000	100	258	QP

Engineer: Lacey	
Site: AC3	Time: 2019/11/21
Limit: FCC_Part15.209_RE(3m)	Margin: 0
Probe: AC3_3m (30-1000MHz)	Polarity: Vertical
EUT: Wireless Access Point	Power: AC 120V/60Hz
Note: Simultaneous transmission with 2.4G WIFI +5G WIFI + BLE	

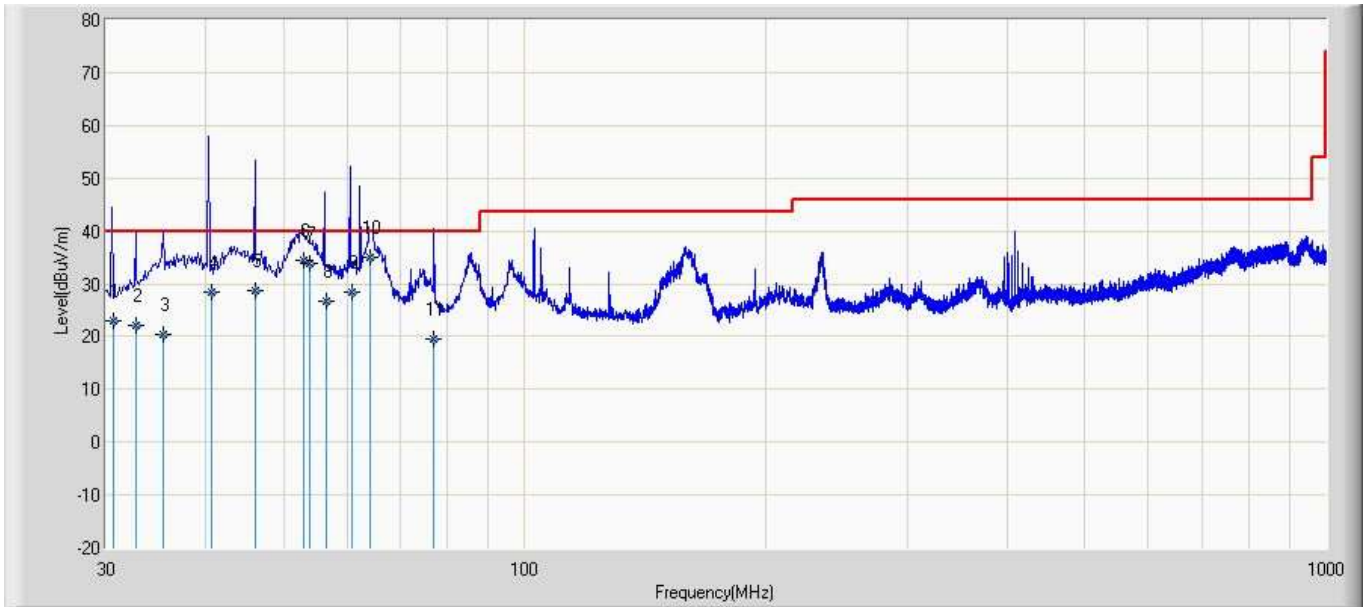

No	Mark	Frequency (MHz)	Measure Level (dBuV/m)	Reading Level (dBuV)	Over Limit (dB)	Limit (dBuV/m)	Probe (dB/m)	Cable (dB)	Amp (dB)	Ant Pos (cm)	Table Pos (deg)	Type
1		30.718	22.874	-1.000	-17.126	40.000	17.415	6.459	0.000	100	211	QP
2		32.667	22.042	-1.200	-17.958	40.000	16.773	6.469	0.000	100	20	QP
3		35.335	20.518	-1.800	-19.482	40.000	15.824	6.494	0.000	100	28	QP
4		40.685	28.368	10.400	-11.632	40.000	11.438	6.530	0.000	100	174	QP
5		46.054	28.803	10.900	-11.197	40.000	11.336	6.568	0.000	100	174	QP
6		52.916	34.477	17.000	-5.523	40.000	10.868	6.609	0.000	200	250	QP
7		53.794	33.745	16.500	-6.255	40.000	10.629	6.616	0.000	200	260	QP
8		56.615	26.780	10.500	-13.220	40.000	9.653	6.626	0.000	100	174	QP
9		60.877	28.333	12.400	-11.667	40.000	9.281	6.652	0.000	100	174	QP
10	*	64.192	34.971	19.100	-5.029	40.000	9.200	6.671	0.000	100	268	QP
11		77.045	19.665	5.000	-20.335	40.000	7.923	6.742	0.000	100	40	QP

Note:

- " * ", means this data is the worst emission level.
- Measurement Level = Reading Level + Factor(Probe+Cable-Amp).

The worst case of Simultaneous Radiated Emission:

Engineer: Simon	
Site: AC5	Time: 2020/03/10
Limit: FCC_Part15.209_RE(3m)	Margin: 0
Probe: Horn_3117_00167055(1-18GHz)	Polarity: Vertical
EUT: Wireless Access Point	Power: AC 120V/60Hz
Note: Simultaneous transmission with 2.4G WIFI +5G WIFI + BLE	

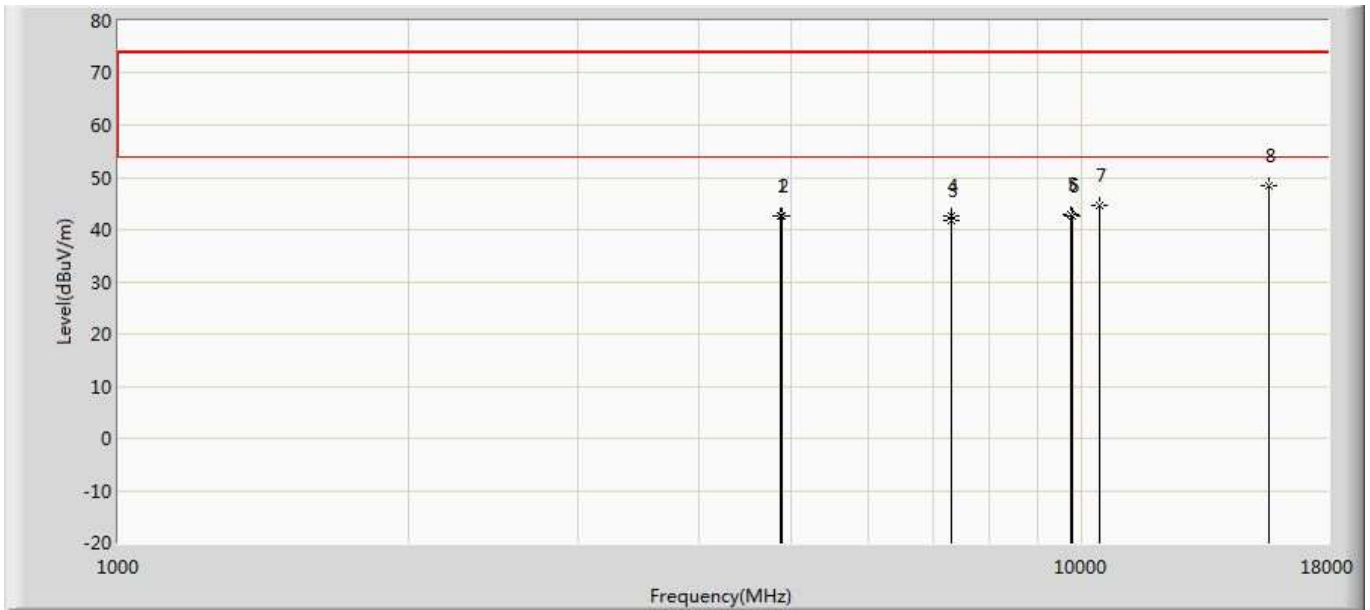

No	Mark	Frequency (MHz)	Measure Level (dBuV/m)	Reading Level (dBuV)	Over Limit (dB)	Limit (dBuV/m)	Factor (dB)	Type
1		4874.000	42.693	35.926	-31.307	74.000	6.767	PK
2		4880.000	42.618	35.890	-31.382	74.000	6.729	PK
3		7311.000	41.706	32.218	-32.294	74.000	9.488	PK
4		7320.000	42.472	32.982	-31.528	74.000	9.490	PK
5		9748.000	43.036	29.396	-30.964	74.000	13.640	PK
6		9760.000	42.712	29.247	-31.288	74.000	13.466	PK
7		10440.000	44.525	30.687	-29.475	74.000	13.838	PK
8	*	15660.000	48.432	28.131	-25.568	74.000	20.301	PK

Engineer: Simon	
Site: AC5	Time: 2020/3/10
Limit: FCC_Part15.209_RE(3m)	Margin: 0
Probe: Horn_3117_00167055(1-18GHz)	Polarity: Horizontal
EUT: Wireless Access Point	Power: AC 120V/60Hz
Note: Simultaneous transmission with 2.4G WIFI +5G WIFI + BLE	

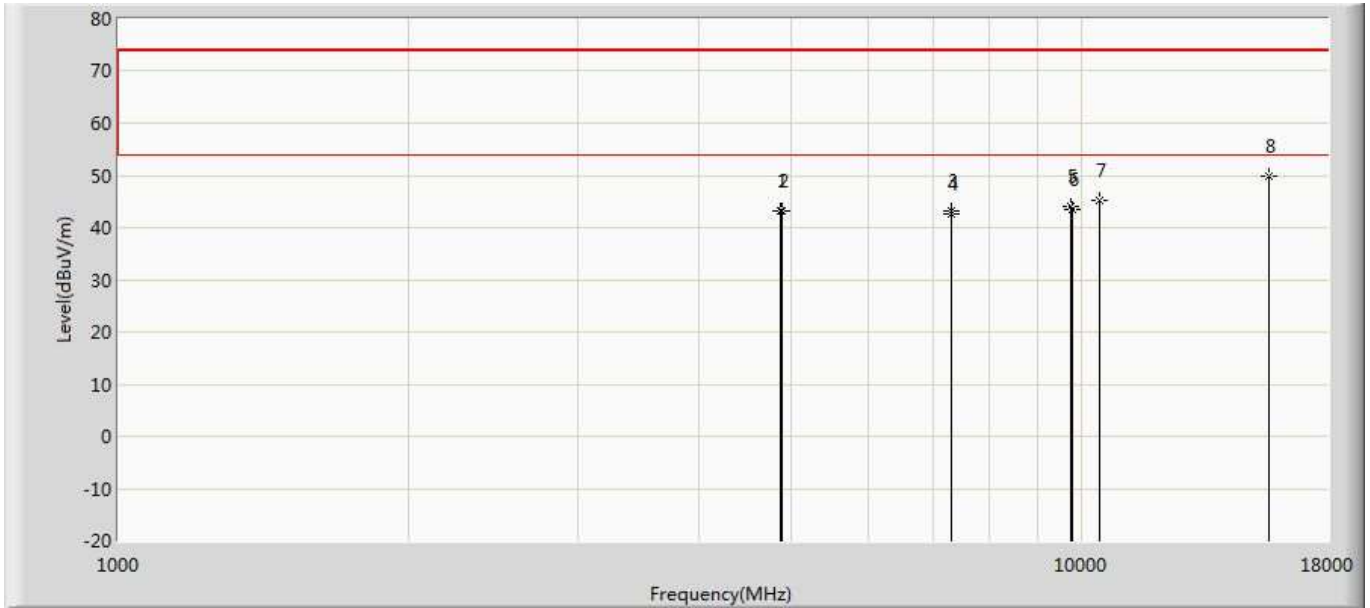

No	Mark	Frequency (MHz)	Measure Level (dBuV/m)	Reading Level (dBuV)	Over Limit (dB)	Limit (dBuV/m)	Factor (dB)	Type
1		4874.000	43.141	36.374	-30.859	74.000	6.767	PK
2		4880.000	43.187	36.459	-30.813	74.000	6.729	PK
3		7311.000	43.185	33.697	-30.815	74.000	9.488	PK
4		7320.000	42.735	33.245	-31.265	74.000	9.490	PK
5		9748.000	44.113	30.473	-29.887	74.000	13.640	PK
6		9760.000	43.340	29.875	-30.660	74.000	13.466	PK
7		10440.000	45.294	31.456	-28.706	74.000	13.838	PK
8	*	15660.000	49.777	29.476	-24.223	74.000	20.301	PK

5. Emissions in non-restricted frequency bands

5.1. Test Equipment

Emissions in non-restricted frequency bands / TR-8					
Instrument	Manufacturer	Type No.	Serial No.	Cal. Date	Cal. Due Date
Spectrum Analyzer	Agilent	N9010A	MY48030494	2020.02.04	2021.02.03
EXA Spectrum Analyzer	Keysight	N9010A	MY55370495	2019.04.09	2020.04.08
MXA Signal Analyzer	Keysight	N9020A	MY56060147	2019.04.09	2020.04.08
Temperature/Humidity Meter	zhichen	ZC1-2	TR8-TH	2019.04.10	2020.04.09

Note: All equipment are calibrated with traceable calibrations. Each calibration is traceable to the national or international standards.

5.2. Test Setup

Emissions in non-restricted frequency bands

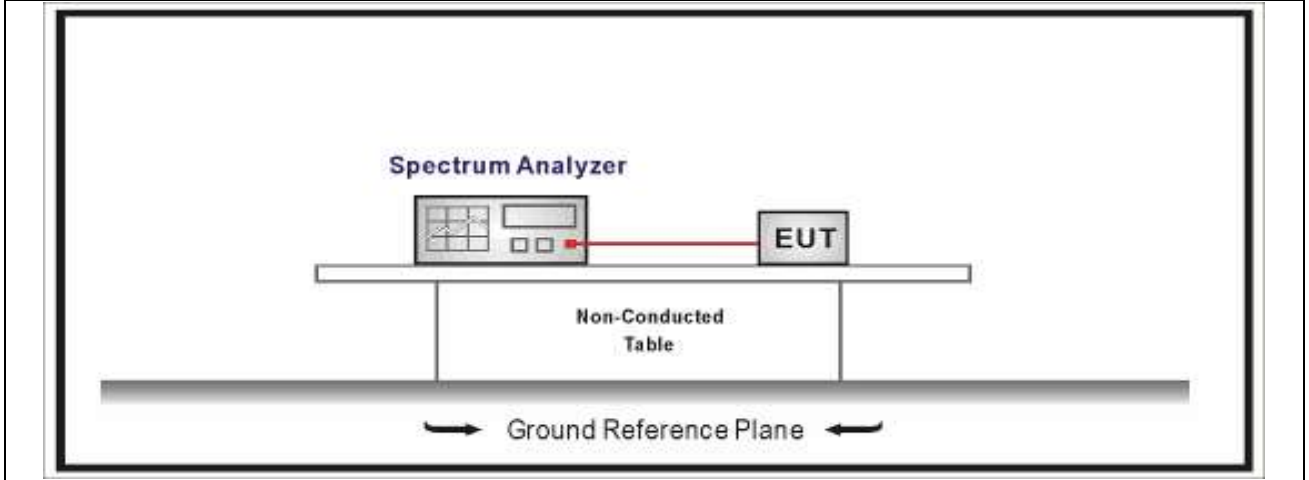



5.3. Limit

Un-Restricted Band Emissions Limit	
RF Output power (Detection methods)	Limit(dB)
RF Output power(Average detector)	30c(Note1)
RF Output power(PK detector)	20c(Note2)
<p>Note 1: If maximum conducted (average) output power was used to demonstrate compliance as described in 9.2, then the peak power in any 100 kHz bandwidth outside of the authorized frequency band shall be attenuated by at least 30 dB relative to the maximum in-band peak PSD level in 100 kHz (i.e., 30 dBc).</p> <p>Note 2: If the maximum peak conducted output power procedure was used, then the peak output power measured in any 100 kHz bandwidth outside of the authorized frequency band shall be attenuated by at least 20 dB relative to the maximum in-band peak PSD level in 100 kHz (i.e., 20 dBc).</p>	

5.4. Test Procedure

Test Method			
	References Rule	Chapter	Description
<input checked="" type="checkbox"/>	ANSI C63.10	11.11	Emissions in non-restricted frequency bands
	<input checked="" type="checkbox"/> ANSI C63.10	11.11.2	Reference level measurement
	<input checked="" type="checkbox"/> ANSI C63.10	11.11.3	Emission level measurement
<input type="checkbox"/>	ANSI C63.10	11.12	Emissions in restricted frequency bands
	<input type="checkbox"/> ANSI C63.10	11.12.1	Radiated emission measurements
	<input type="checkbox"/> ANSI C63.10	11.12.2.7	Radiated spurious emission test
<input type="checkbox"/>	ANSI C63.10	6.4	Radiated emissions from unlicensed wireless devices below 30 MHz
<input type="checkbox"/>	ANSI C63.10	6.5	Radiated emissions from unlicensed wireless devices in the frequency range of 30 MHz to 1000 MHz
<input type="checkbox"/>	ANSI C63.10	6.6	Radiated emissions from unlicensed wireless devices above 1 GHz
	<input type="checkbox"/> ANSI C63.10	11.12.2	Antenna-port conducted measurements
	<input type="checkbox"/> ANSI C63.10	11.12.2.3	Quasi-peak measurement procedure
	<input type="checkbox"/> ANSI C63.10	11.12.2.4	Peak power measurement procedure
	<input type="checkbox"/> ANSI C63.10	11.12.2.5	Average power measurement procedures
	<input type="checkbox"/> ANSI C63.10	11.12.2.5.1	Trace averaging with continuous EUT transmission at full power
	<input type="checkbox"/> ANSI C63.10	11.12.2.5.2	Trace averaging across ON and OFF times of the EUT transmissions followed by duty cycle correction
	<input type="checkbox"/> ANSI C63.10	11.12.2.5.3	Reduced VBW averaging across ON and OFF times of the EUT transmissions with max hold

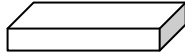
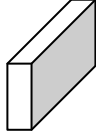
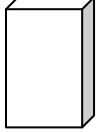
5.5. EUT test Axis definition

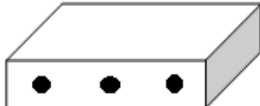
Item	Emissions in non-restricted frequency bands			
Device Category	<input type="checkbox"/>	Fixed point-to-point		
	<input type="checkbox"/>	Emit multiple directional beams, simultaneously or sequentially		
	<input checked="" type="checkbox"/>	Other cases		
Test mode	Mode 1~4			
Test method	<input type="checkbox"/>	Radiated		
		X Axis	Y Axis	Z Axis
				
		Worst Axis <input type="checkbox"/>	Worst Axis <input type="checkbox"/>	Worst Axis <input type="checkbox"/>
	<input checked="" type="checkbox"/>	Conducted		
	<input checked="" type="checkbox"/>	Chain 1		
				
	<input checked="" type="checkbox"/>	Chain 1	Chain 2	
				
	<input type="checkbox"/>	Chain 1	Chain 2	Chain 3
				

5.6. Test Result

Product Name	: Wireless Access Point	Power	: AC 120V/60Hz
Test Mode	: Mode 1~4(Radio 1)	Test Site	: TR8
Test Date	: 2019.11.09	Test Engineer	: Eric

Mode	Channel	Test Frequency (MHz)	Maximum In-Band PSD[a] (dBm/100kHz)	Frequency (MHz)	Out-Band PSD[b] (dBm/100kHz)	[a]-[b] (dB)	Limit (dB)	Result
1	01	2412	15.013	2398.501	-21.815	36.828	>30	Pass
1	11	2462	15.172	2554.194	-54.738	69.910	>30	Pass
2	01	2412	7.562	2399.176	-25.055	32.617	>30	Pass
2	11	2462	8.376	2577.948	-55.246	63.622	>30	Pass
3	01	2412	7.540	2399.878	-22.780	30.320	>30	Pass
3	11	2462	8.218	2532.845	-54.427	62.645	>30	Pass
4	01	2412	7.533	2399.653	-22.933	30.466	>30	Pass
4	11	2462	8.229	2586.014	-53.611	61.840	>30	Pass

Note: The worst case of emissions in non-restricted frequency bands as below:

Mode 3 CH01(2412MHz)

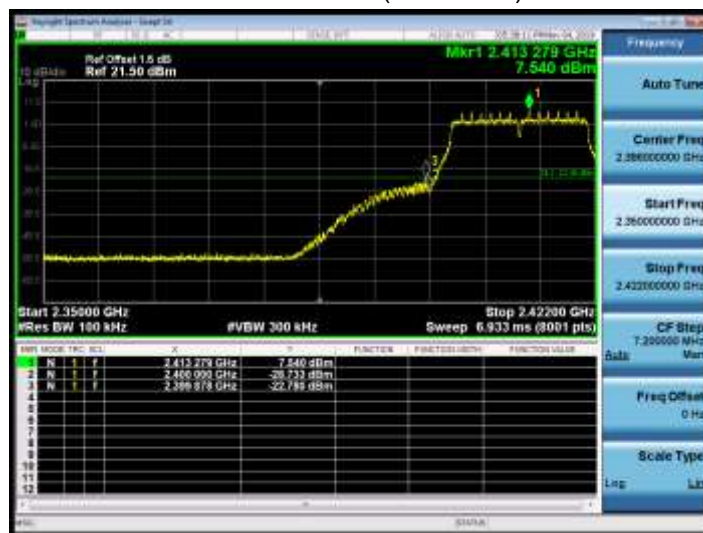

Product Name	: Wireless Access Point	Power	: AC 120V/60Hz
Test Mode	: Mode 1~4(Radio 2)	Test Site	: TR8
Test Date	: 2019.11.09	Test Engineer	: Eric

Mode	Channel	Test Frequency (MHz)	Maximum In-Band PSD[a] (dBm/100kHz)	Frequency (MHz)	Out-Band PSD[b] (dBm/100kHz)	[a]-[b] (dB)	Limit (dB)	Result
1	01	2412	14.900	2398.519	-22.144	37.044	>30	Pass
1	11	2462	15.067	2519.266	-55.876	70.943	>30	Pass
2	01	2412	7.558	2399.176	-25.376	32.934	>30	Pass
2	11	2462	8.340	2536.491	-55.717	64.057	>30	Pass
3	01	2412	7.612	2399.383	-24.098	31.710	>30	Pass
3	11	2462	8.292	2578.669	-55.245	63.537	>30	Pass
4	01	2412	7.347	2399.644	-23.446	30.793	>30	Pass
4	11	2462	8.129	2503.467	-56.196	64.325	>30	Pass

Note: The worst case of emissions in non-restricted frequency bands as below:

Mode 4 CH01(2412MHz)

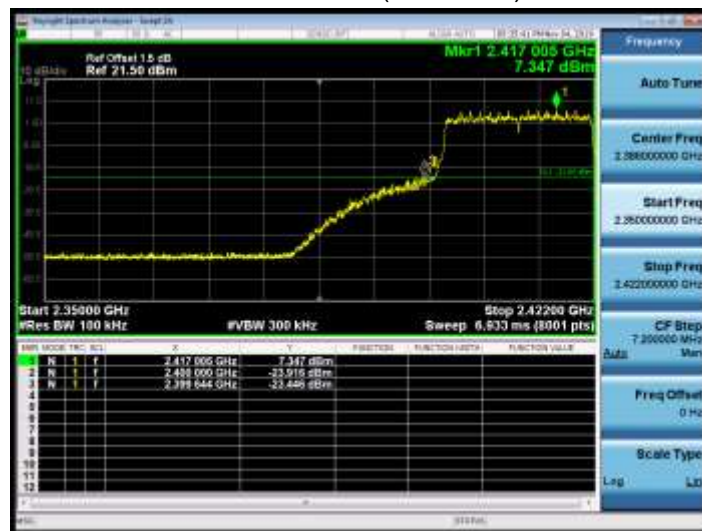

6. Band Edge

6.1. Test Equipment

Emissions in non-restricted frequency bands / TR-8					
Instrument	Manufacturer	Type No.	Serial No.	Cal. Date	Cal. Due Date
Spectrum Analyzer	Agilent	N9010A	MY48030494	2020.02.04	2021.02.03
Signal Analyzer	R&S	FSV	104212	2020.02.23	2021.02.22
EXA Spectrum Analyzer	Keysight	N9010A	MY55370495	2019.04.09	2020.04.08
MXA Signal Analyzer	Keysight	N9020A	MY56060147	2019.04.09	2020.04.08
Temperature/Humidity Meter	zhichen	ZC1-2	TR8-TH	2019.04.10	2020.04.09

Note: All equipment are calibrated with traceable calibrations. Each calibration is traceable to the national or international standards.

6.2. Test Setup

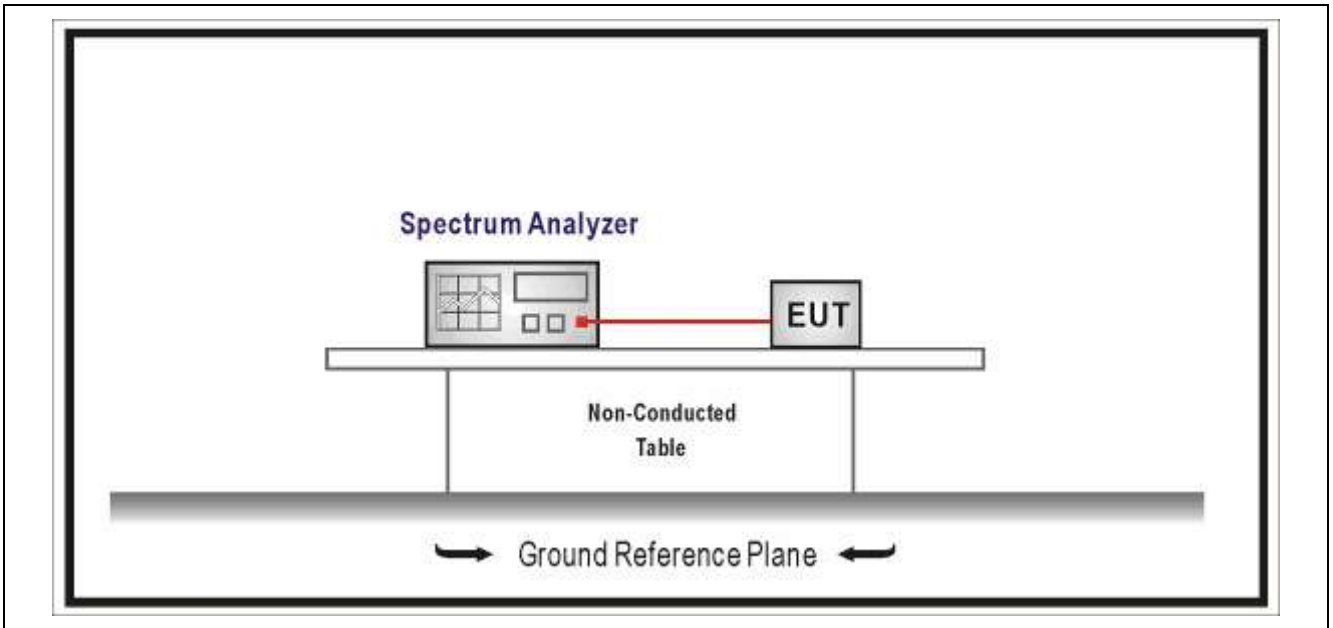

6.3. Limit





Band edge Limit				
Frequency bands (MHz)	Detector	Limit (dB μ V/m)	RBW (MHz)	Distance (m)
2310-2390	PK	74	1	3
2483.5-2500	AV	54	1	3

Note: The field strength of emissions appearing within these frequency bands shall not exceed the limits.

6.4. Test Procedure

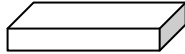
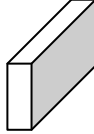
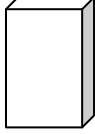
Test Method			
	References Rule	Chapter	Description
<input checked="" type="checkbox"/>	ANSI C63.10	6.10	Band-edge testing
	<input checked="" type="checkbox"/> ANSI C63.10	6.10.5	Restricted-band band-edge measurements
	<input type="checkbox"/> ANSI C63.10	6.10.6	Marker-delta method
<input type="checkbox"/>	ANSI C63.10	11.12	Emissions in restricted frequency bands
	<input type="checkbox"/> ANSI C63.10	11.12.1	Radiated emission measurements
	<input type="checkbox"/> ANSI C63.10	11.12.2.7	Radiated spurious emission test
<input type="checkbox"/>	ANSI C63.10	6.4	Radiated emissions from unlicensed wireless devices below 30 MHz
<input type="checkbox"/>	ANSI C63.10	6.5	Radiated emissions from unlicensed wireless devices in the frequency range of 30 MHz to 1000 MHz
<input checked="" type="checkbox"/>	ANSI C63.10	6.6	Radiated emissions from unlicensed wireless devices above 1 GHz
	<input checked="" type="checkbox"/> ANSI C63.10	11.12.2	Antenna-port conducted measurements
	<input type="checkbox"/> ANSI C63.10	11.12.2.3	Quasi-peak measurement procedure
	<input checked="" type="checkbox"/> ANSI C63.10	11.12.2.4	Peak power measurement procedure
	<input checked="" type="checkbox"/> ANSI C63.10	11.12.2.5	Average power measurement procedures
	<input type="checkbox"/> ANSI C63.10	11.12.2.5.1	Trace averaging with continuous EUT transmission at full power
	<input type="checkbox"/> ANSI C63.10	11.12.2.5.2	Trace averaging across ON and OFF times of the EUT transmissions followed by duty cycle correction
	<input type="checkbox"/> ANSI C63.10	11.12.2.5.3	Reduced VBW averaging across ON and OFF times of the EUT transmissions with max hold

6.5. EUT test definition

Item	Radiated Emission Band Edge			
Device Category	<input type="checkbox"/>	Fixed point-to-point		
	<input type="checkbox"/>	Emit multiple directional beams, simultaneously or sequentially		
	<input checked="" type="checkbox"/>	Other cases		
Test mode	Mode 1~4			
Test method	<input type="checkbox"/>	Radiated		
		X Axis	Y Axis	Z Axis
				
		Worst Axis <input type="checkbox"/>	Worst Axis <input type="checkbox"/>	Worst Axis <input type="checkbox"/>
	<input checked="" type="checkbox"/>	Conducted		
	<input checked="" type="checkbox"/>	Chain 1		
				
	<input checked="" type="checkbox"/>	Chain 1	Chain 2	
				
	<input type="checkbox"/>	Chain 1	Chain 2	Chain 3
				

6.6. Duty Cycle

Radio 1

Test Mode	Tx On (ms)	Tx Off (ms)	VBW	Tx On + Tx Off (ms)	Duty Cycle (%)
802.11b	N/A	N/A	10Hz	N/A	100.00
802.11g	2.055	0.120	500Hz	2.175	94.48
802.11n(20MHz)	1.915	0.110	1kHz	2.025	94.57
802.11ax(20MHz)	1.476	0.048	1kHz	1.524	96.85

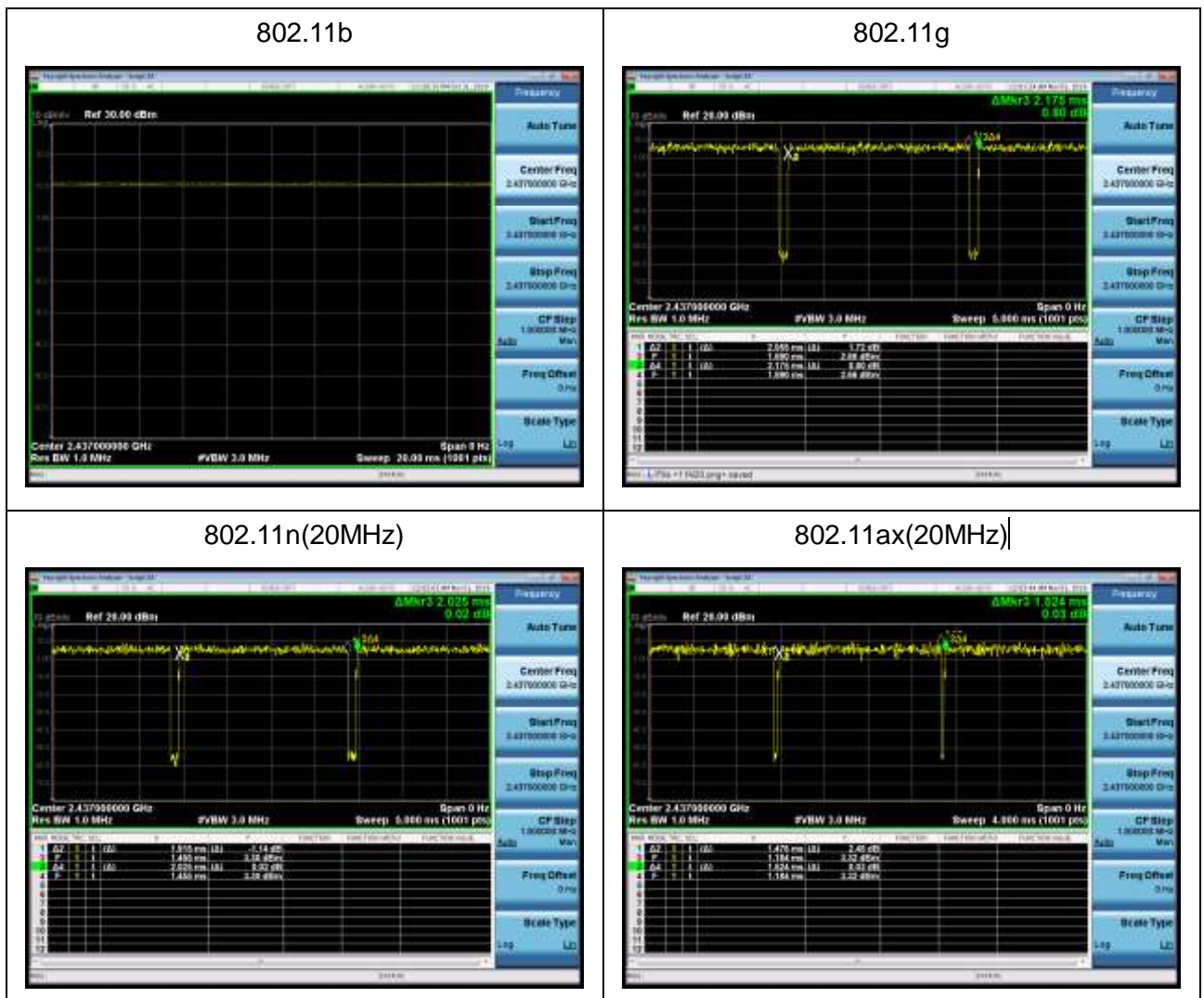

Radio 2

Test Mode	Tx On (ms)	Tx Off (ms)	VBW	Tx On + Tx Off (ms)	Duty Cycle (%)
802.11b	N/A	N/A	10Hz	N/A	100.00
802.11g	2.060	0.110	500Hz	2.170	94.93
802.11n(20MHz)	1.925	0.100	1kHz	2.025	95.06
802.11ax(20MHz)	1.488	0.032	1kHz	1.520	97.89
802.11n(20MHz) with Beamforming	1.915	0.110	1kHz	2.025	94.57
802.11ax(20MHz) with Beamforming	1.480	0.040	1kHz	1.520	97.37

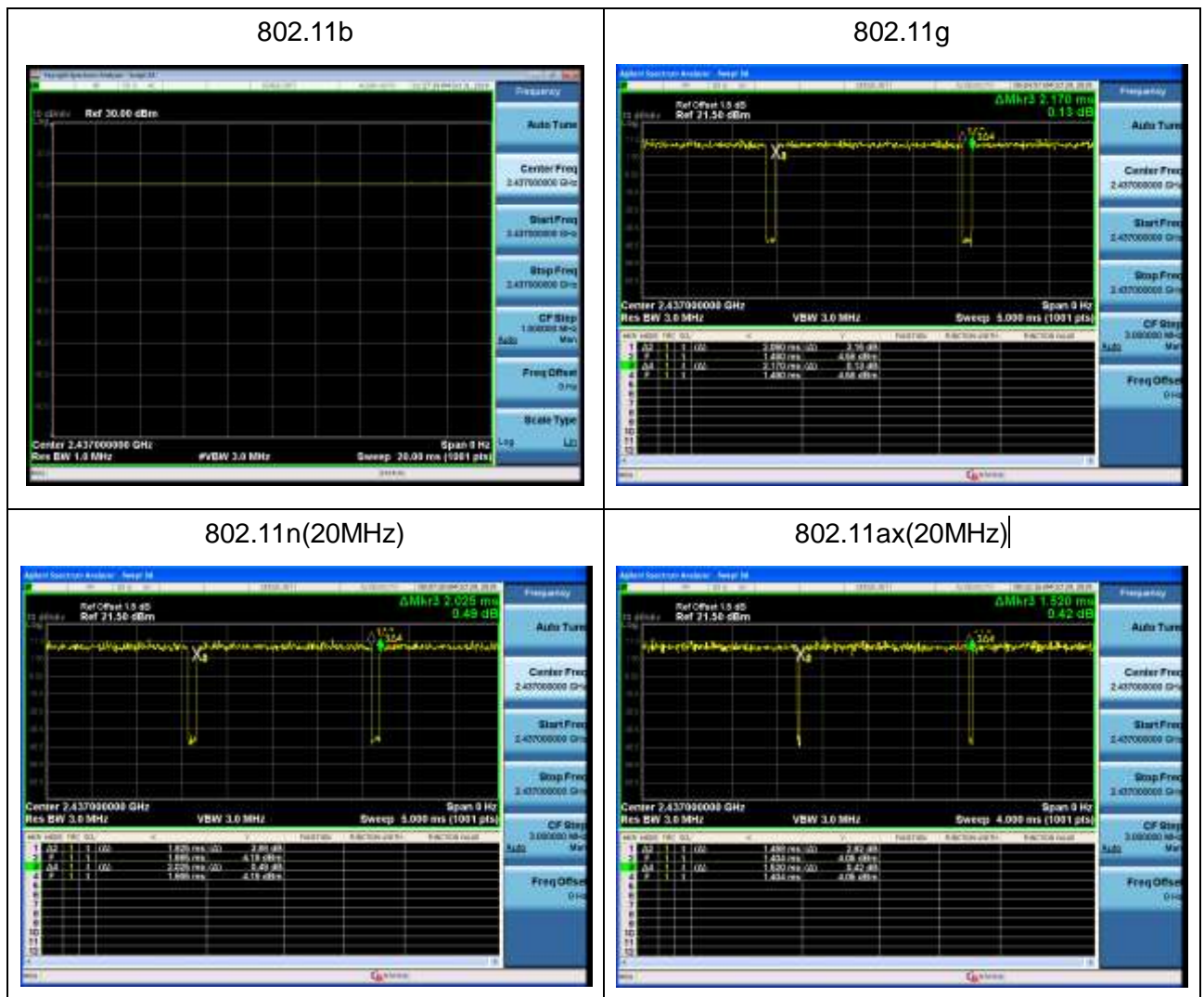

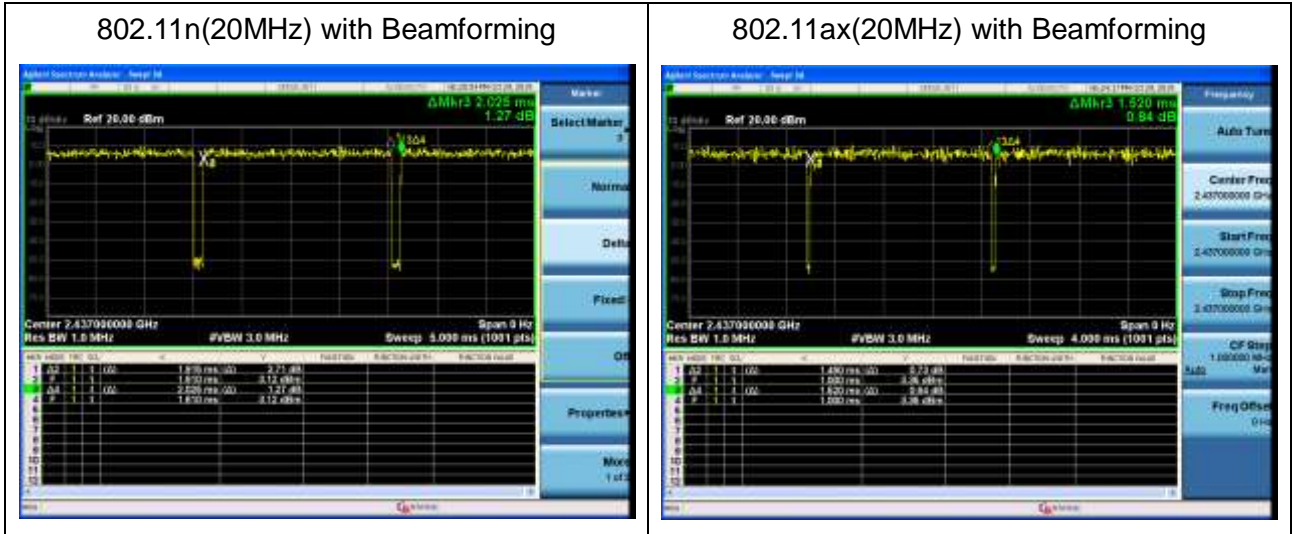

6.7. Test Result

Radio 1:

SISO PK Limit=74dBuV/m-95.2-3.74(Antenna Gain)=-24.94dBm

SISO AV Limit=54dBuV/m-95.2-3.74(Antenna Gain)=-44.94dBm

Radio 2:

SISO PK Limit=74dBuV/m-95.2-3.24(Antenna Gain)=-24.44dBm

SISO AV Limit=54dBuV/m-95.2-3.24(Antenna Gain)=-44.44dBm

CDD/Beamforming PK Limit=74dBuV/m-95.2-10lg2(2Tx)-6.25(Directional Gain)=-30.46dBm

CDD/Beamforming AV Limit=54dBuV/m-95.2-10lg2(2Tx)-6.25(Directional Gain)=-50.46dBm

Note: Above limit is the worst case of AP460C.

Radio 1:
2412MHz by 802.11b:



2417MHz by 802.11b:



2437MHz by 802.11b:

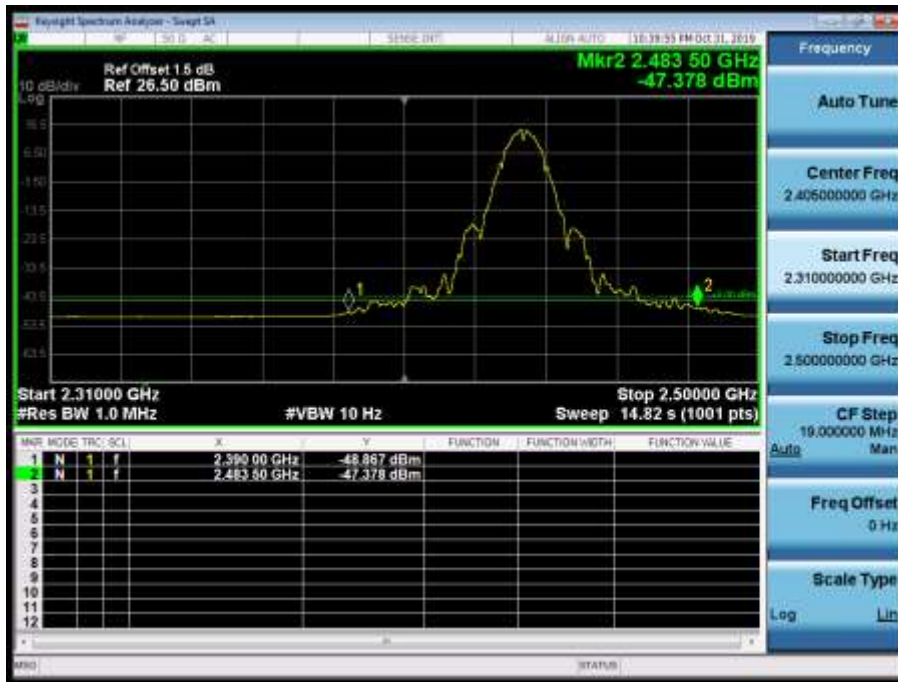

2457MHz by 802.11b:



2462MHz by 802.11b:

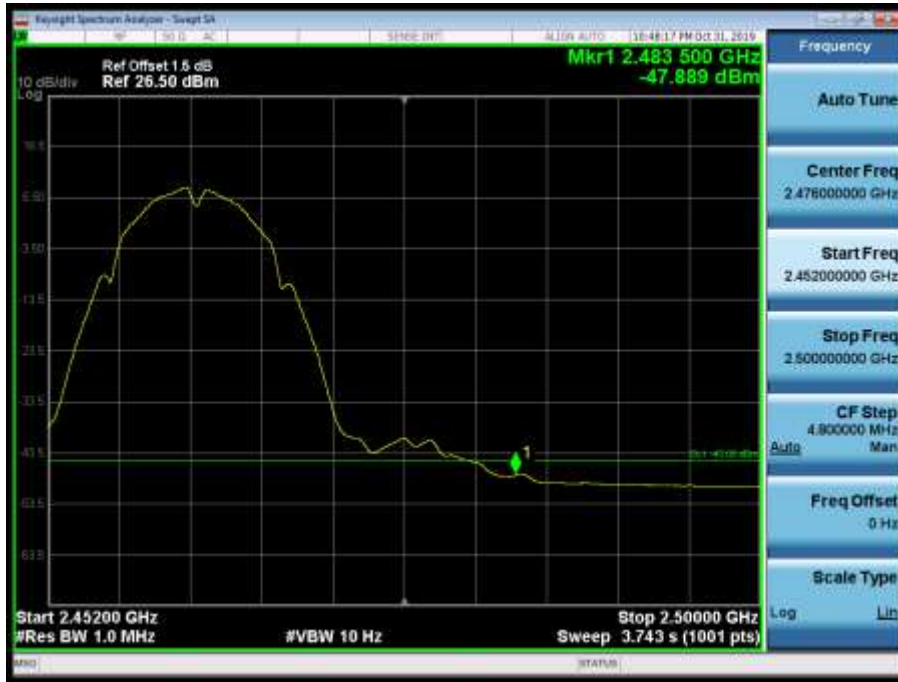

2412MHz by 802.11g:



2417MHz by 802.11g:

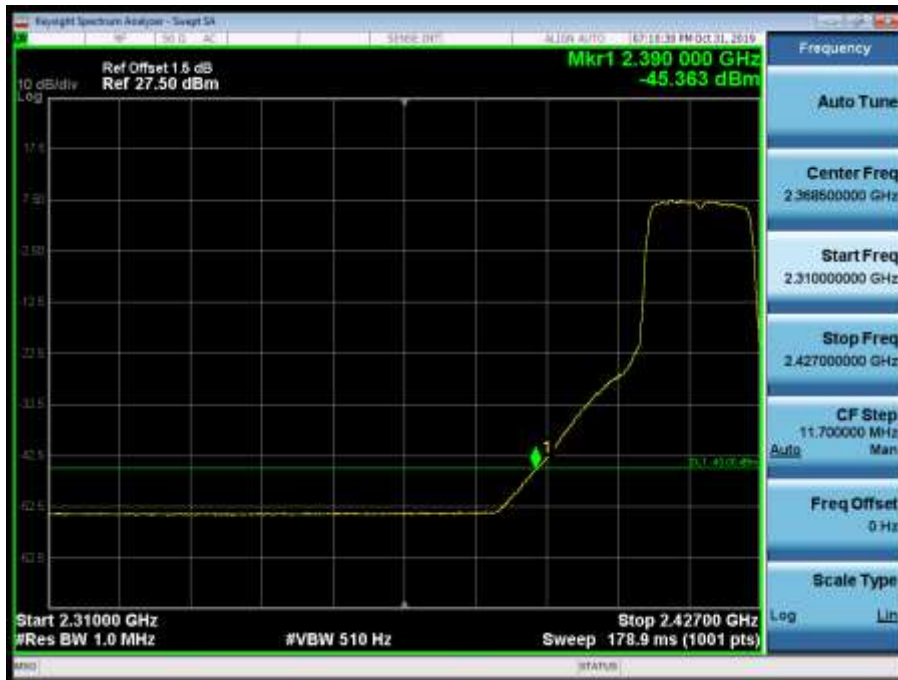

2437MHz by 802.11g:

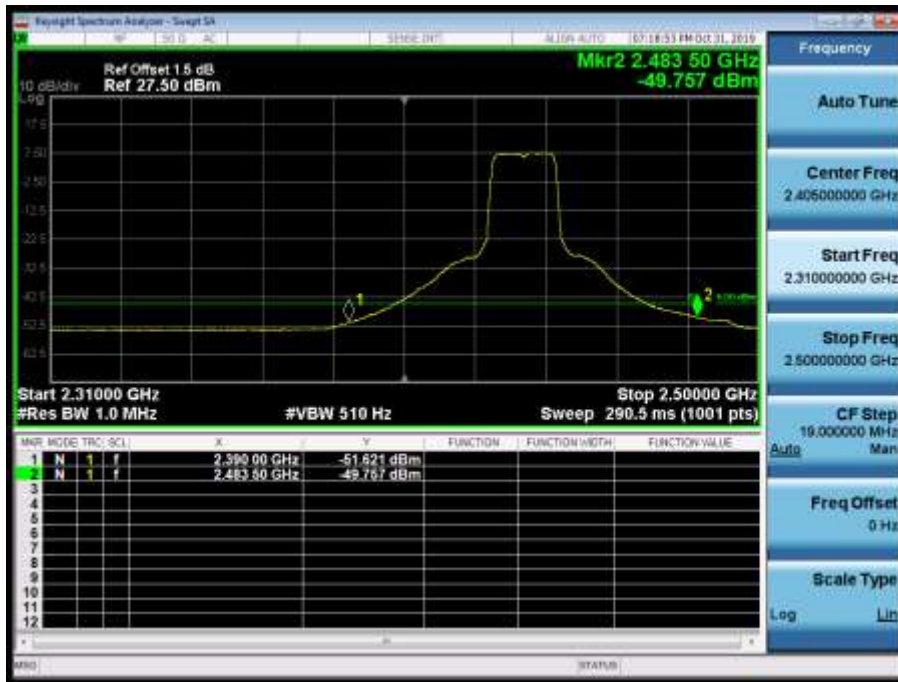

2457MHz by 802.11g:



2462MHz by 802.11g:

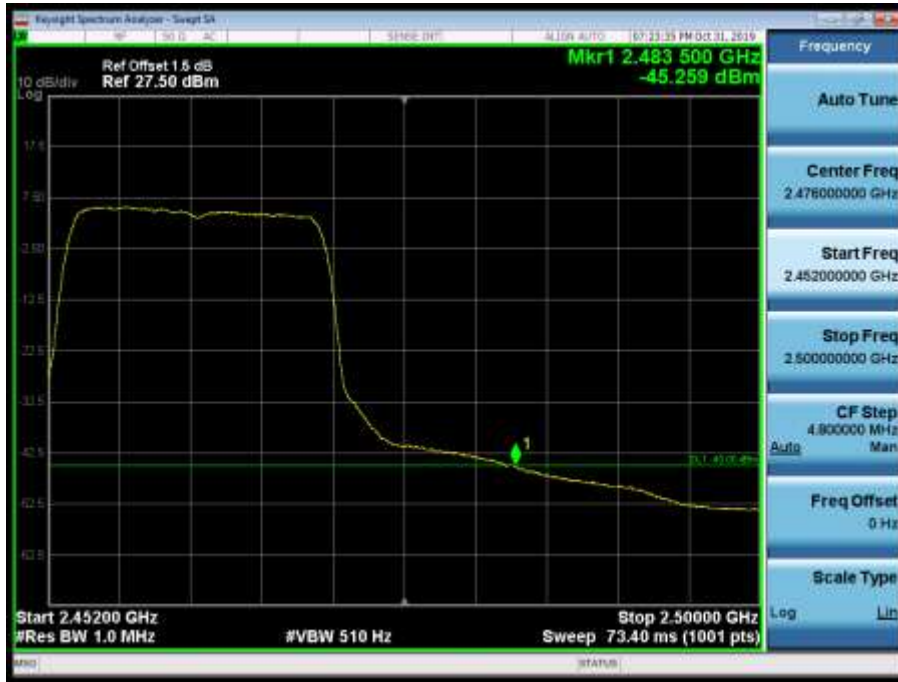

2412MHz by 802.11n(20MHz):

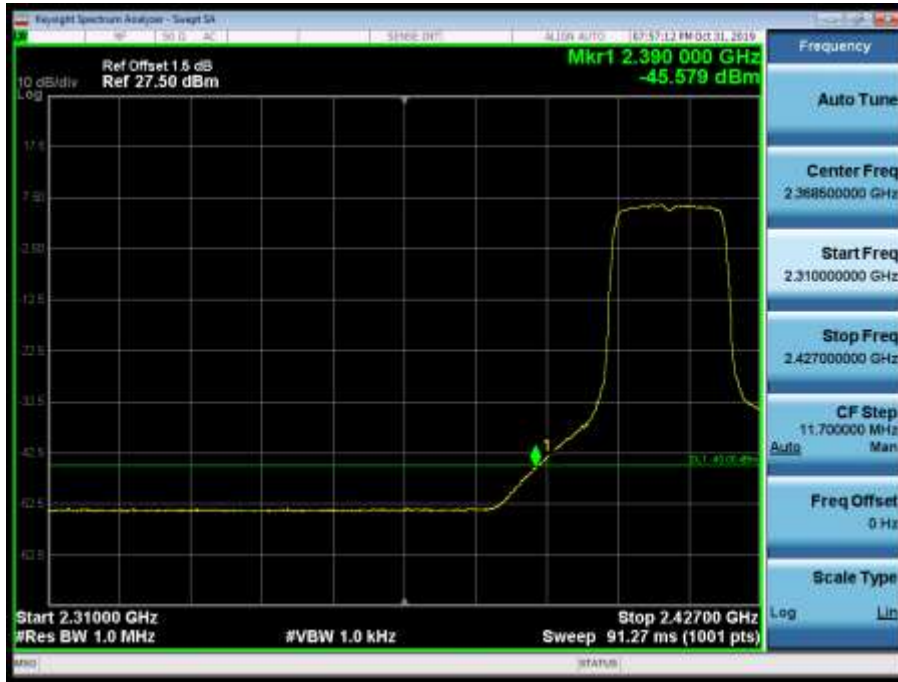

2417MHz by 802.11n(20MHz):

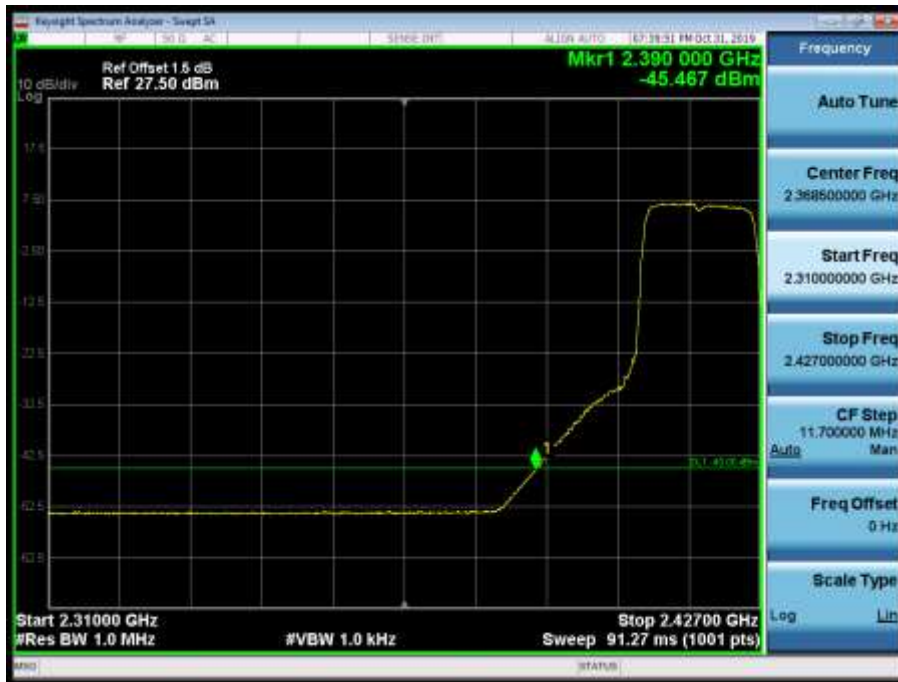

2437MHz by 802.11n(20MHz):

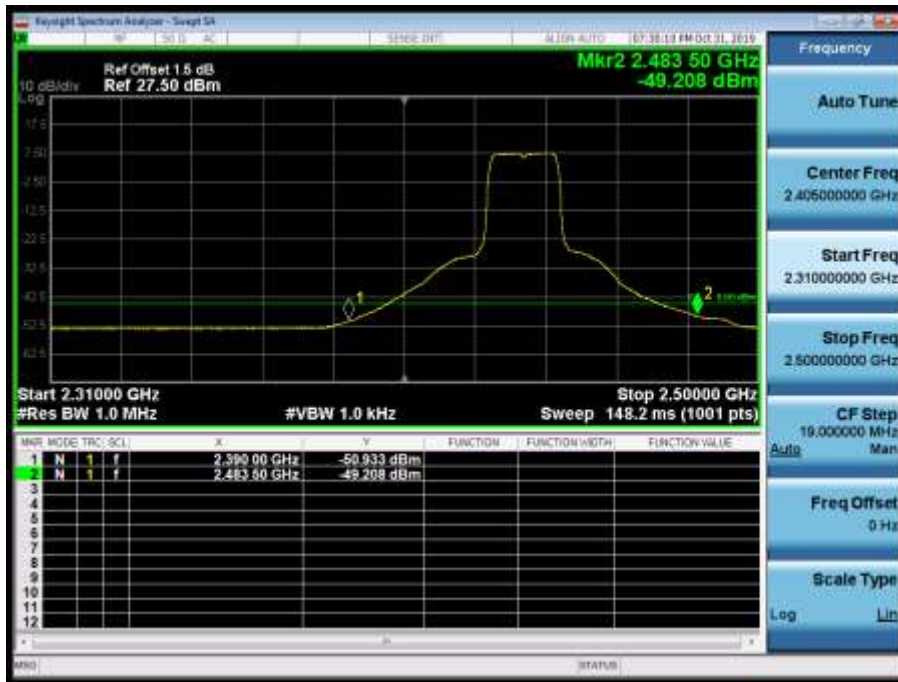

2457MHz by 802.11n(20MHz):

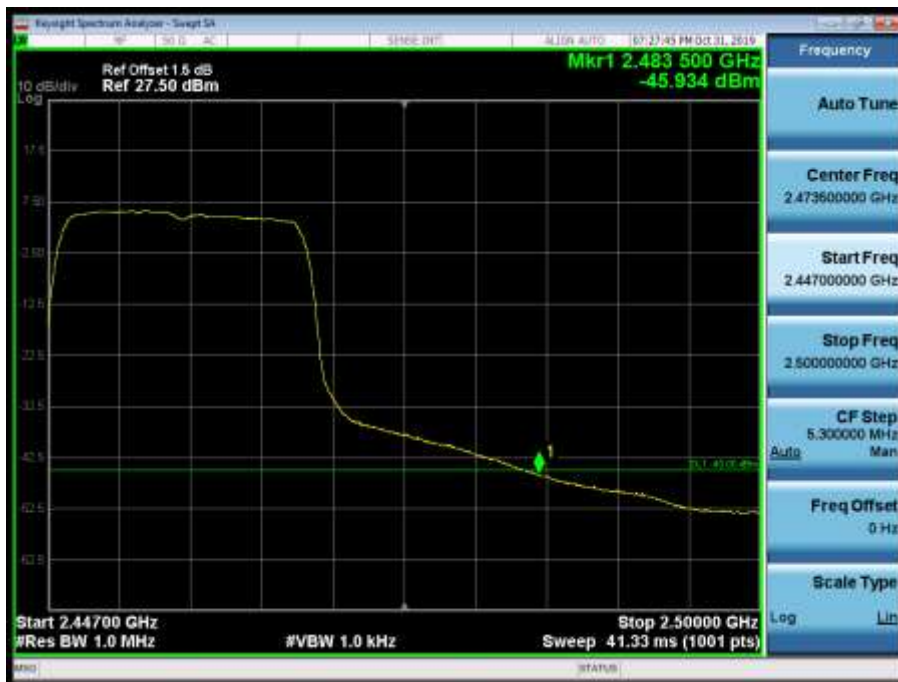

2462MHz by 802.11n(20MHz):

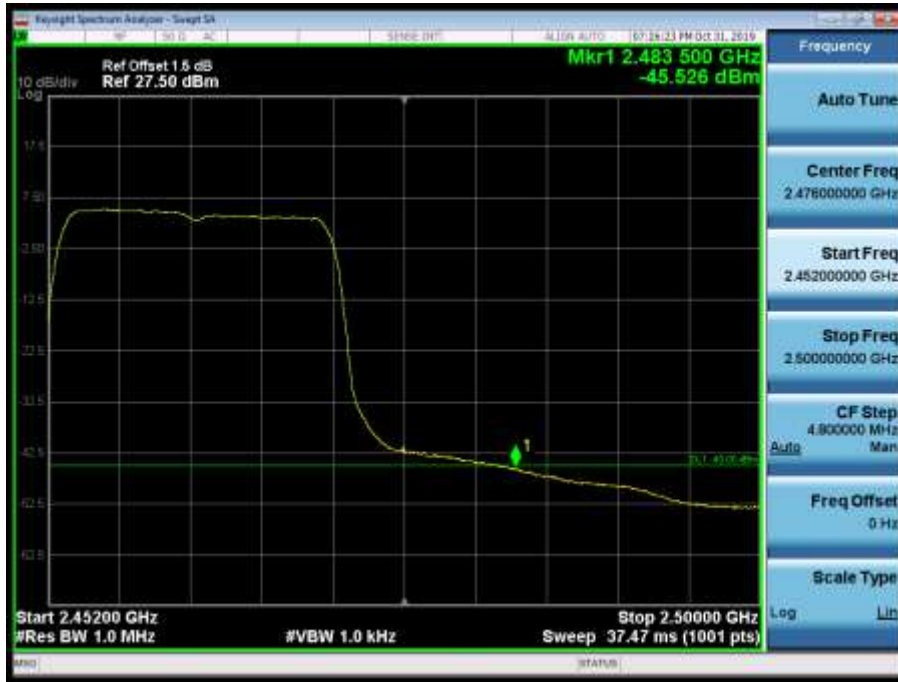

2412MHz by 802.11ax(20MHz):

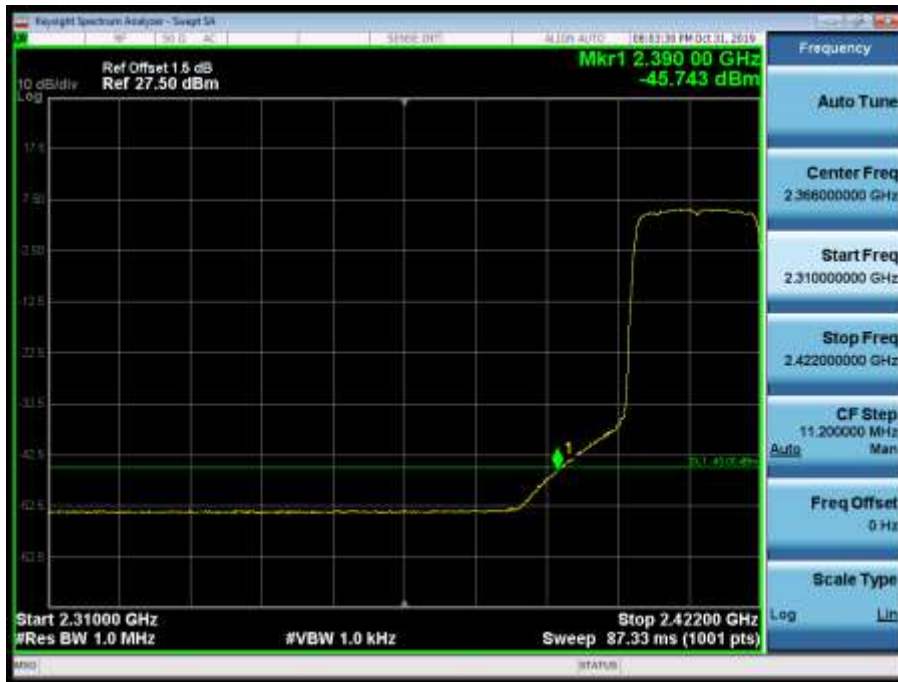

2417MHz by 802.11ax(20MHz):

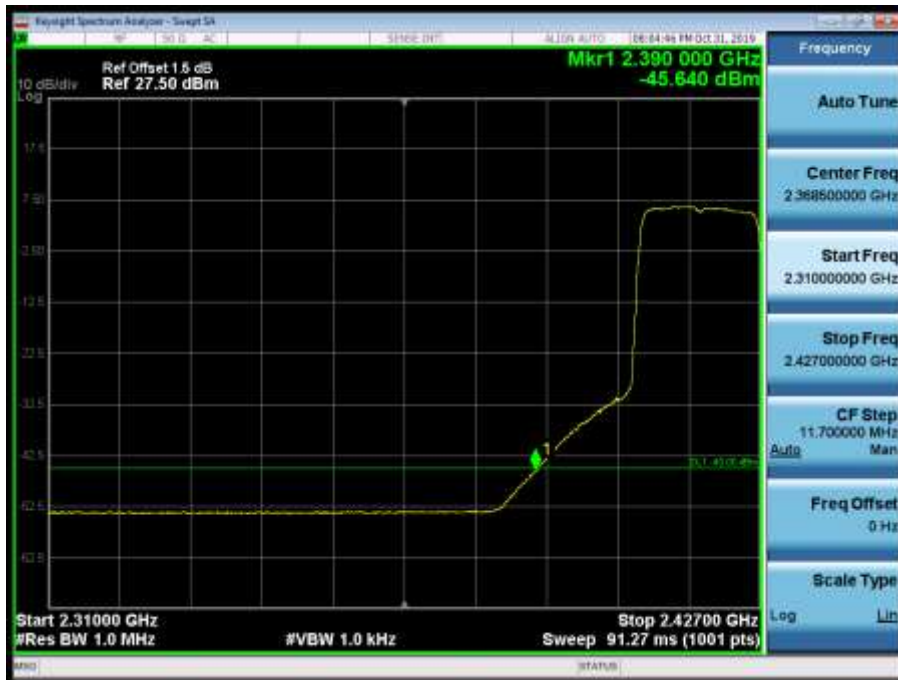

2437MHz by 802.11ax(20MHz):

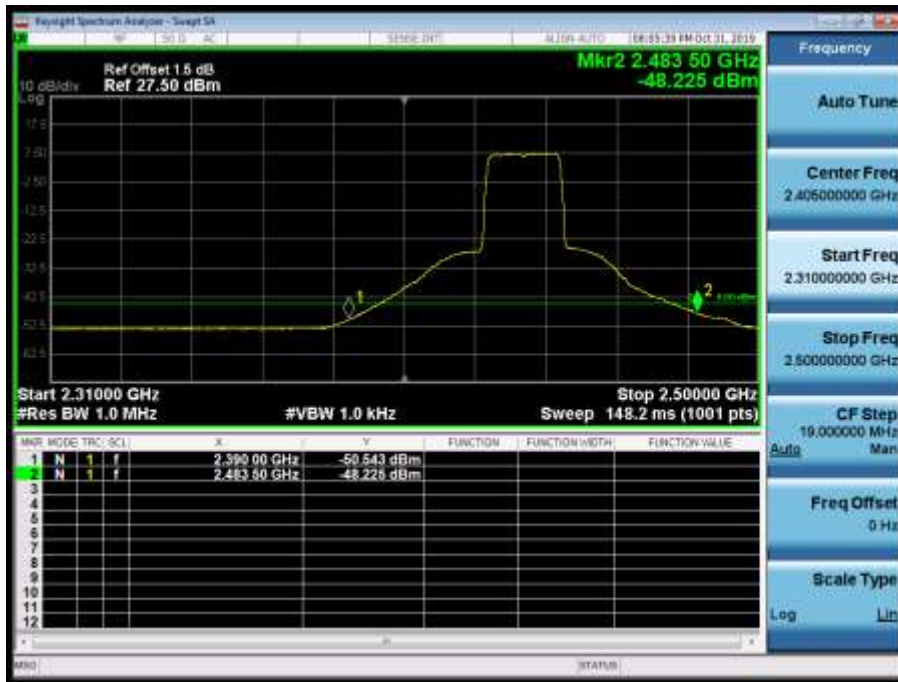

2457MHz by 802.11ax(20MHz):

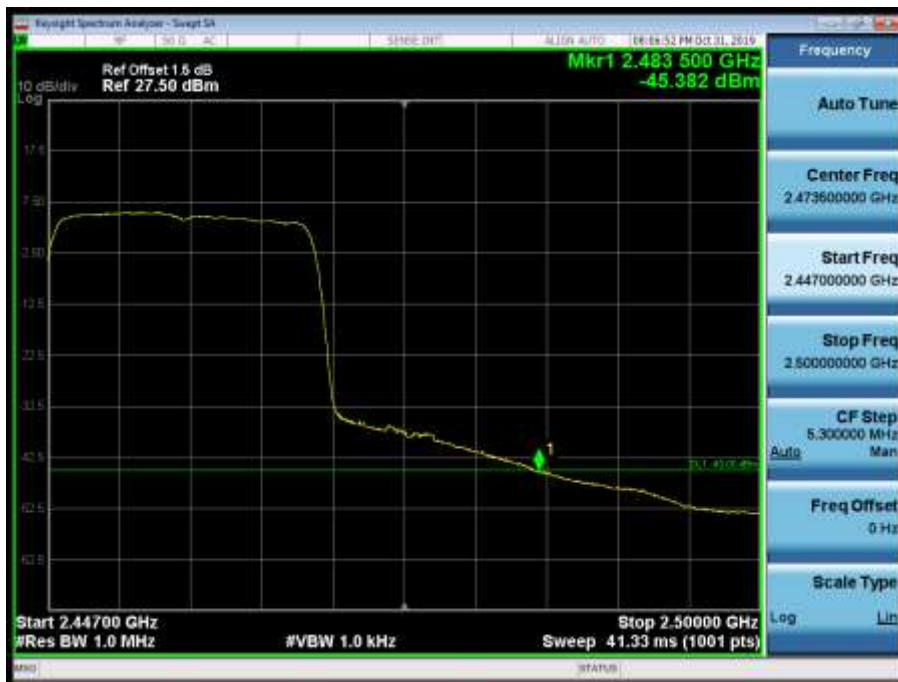

2462MHz by 802.11ax(20MHz):

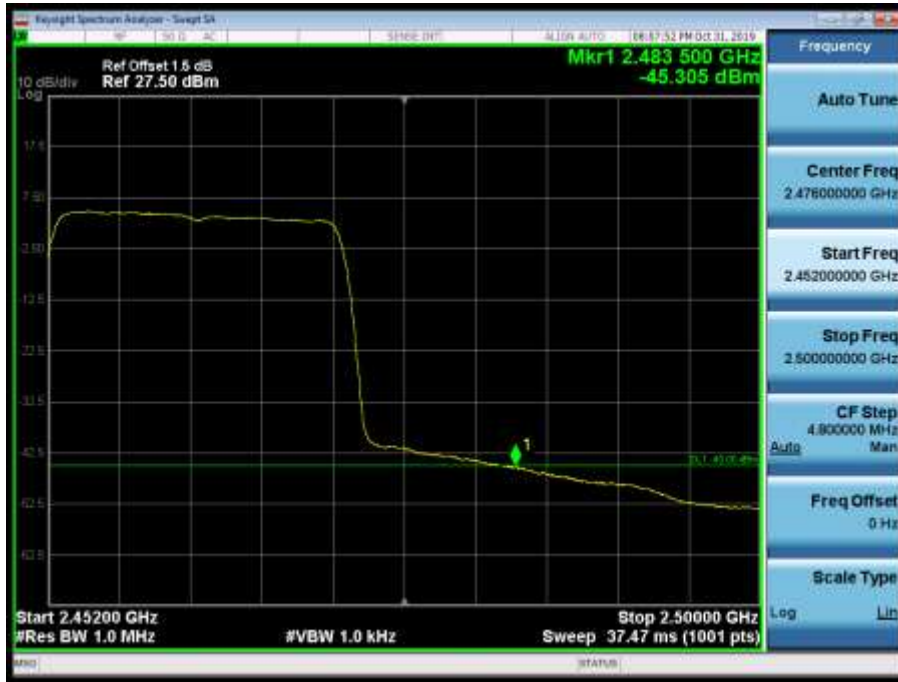

PK Limit-SISO:

2412MHz by 802.11b:

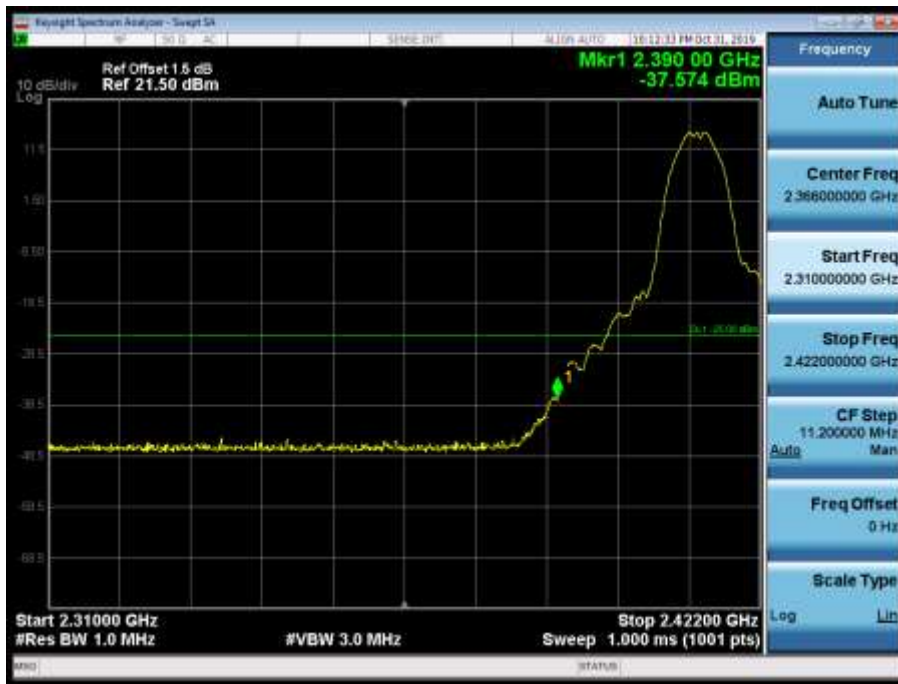

2417MHz by 802.11b:

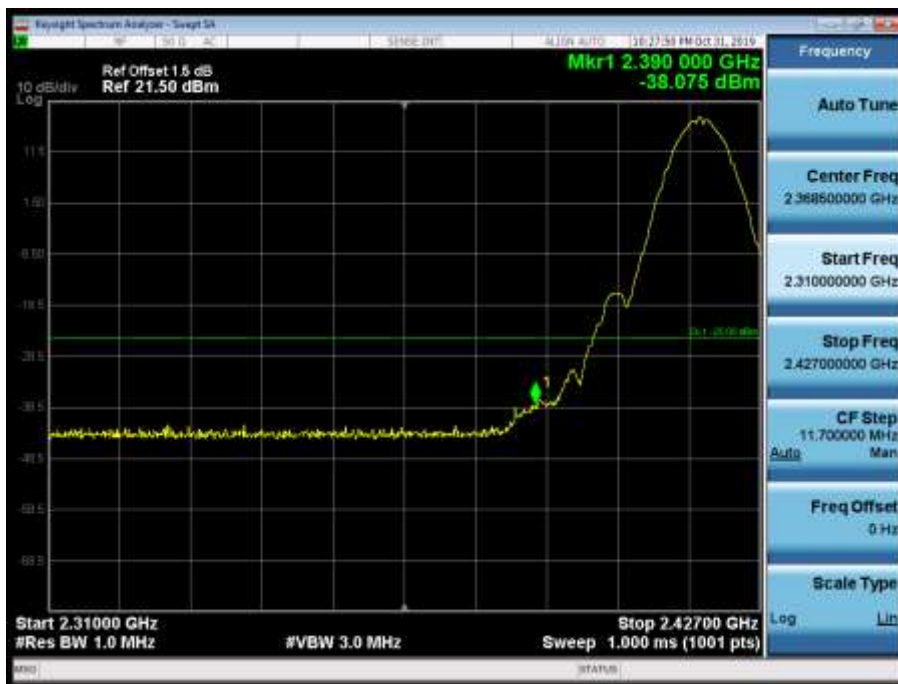

2437MHz by 802.11b:

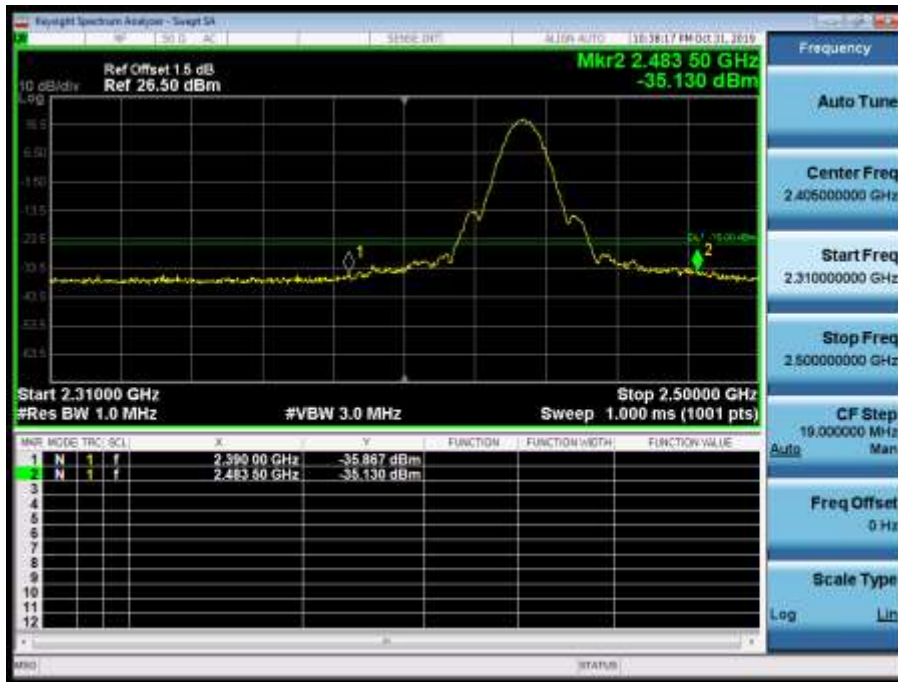

2457MHz by 802.11b:

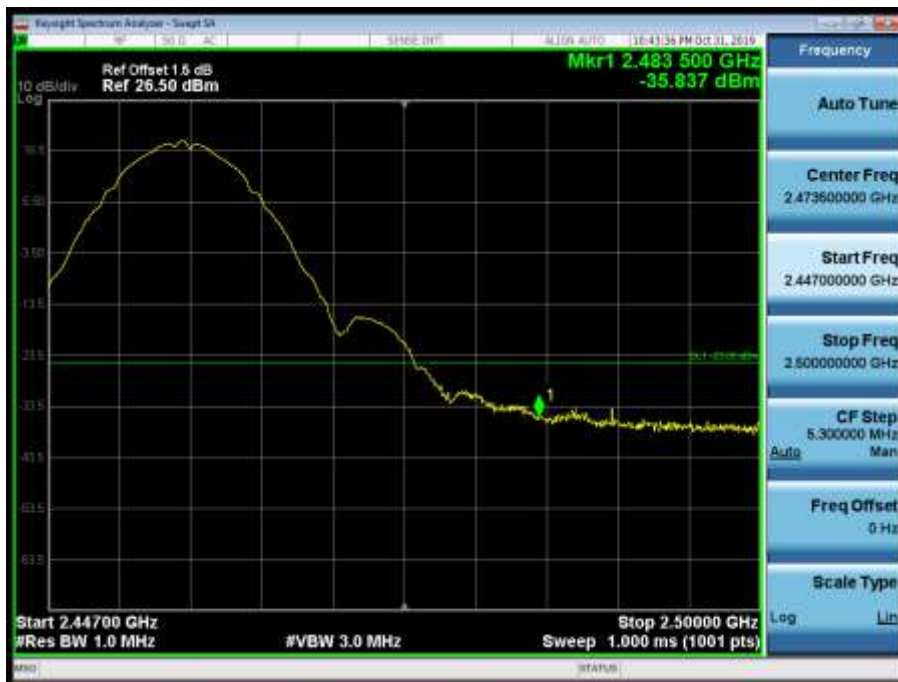

2462MHz by 802.11b:

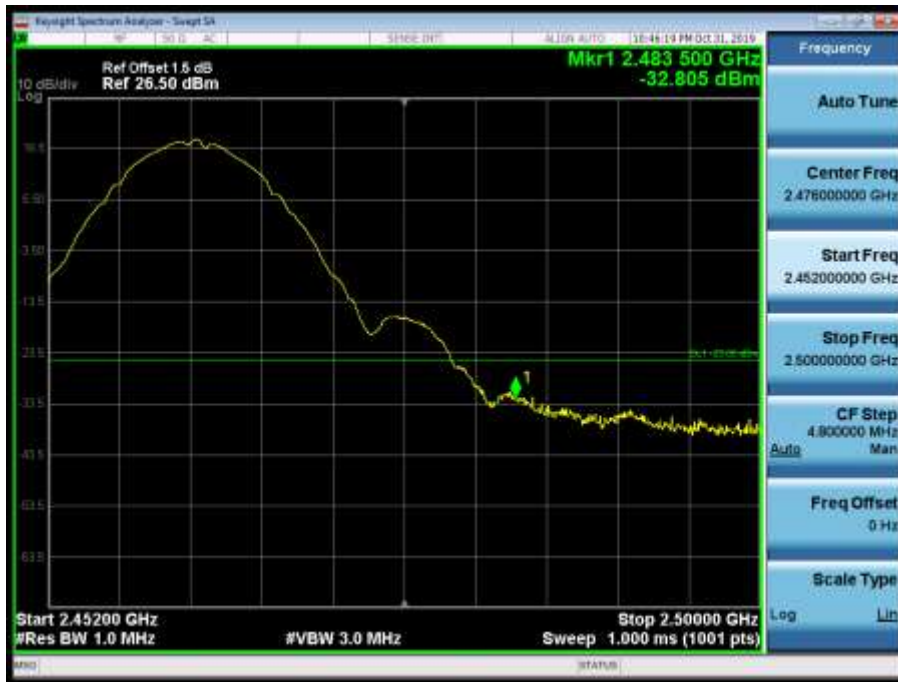

2412MHz by 802.11g:



2417MHz by 802.11g:

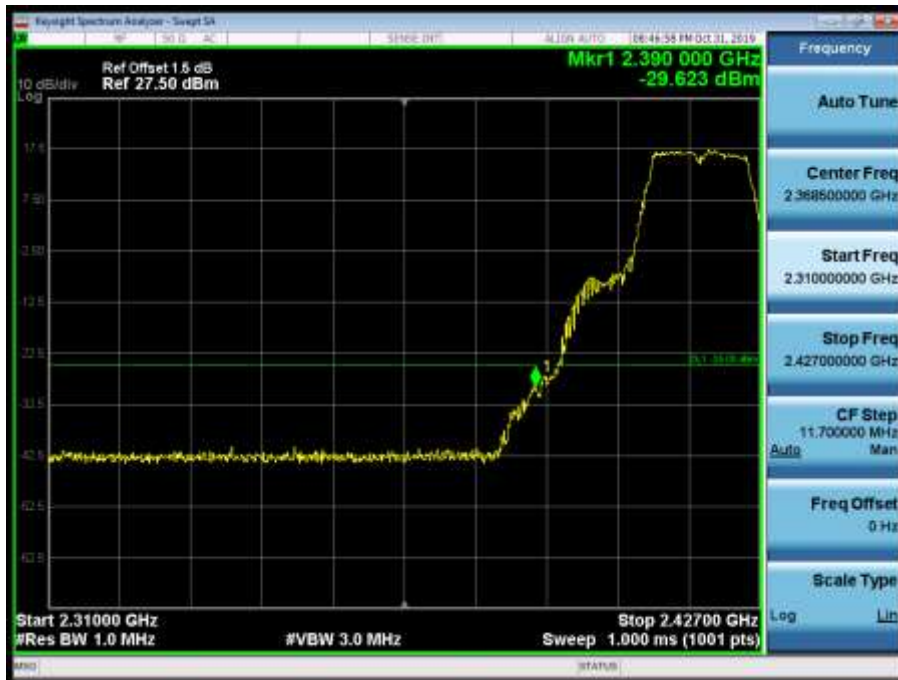

2437MHz by 802.11g:

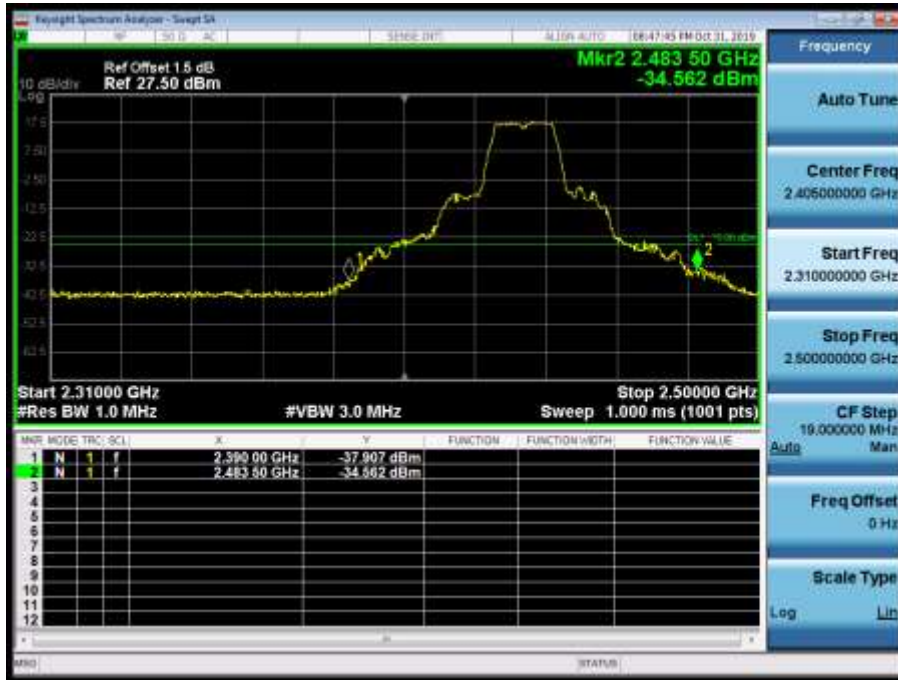

2457MHz by 802.11g:



2462MHz by 802.11g:

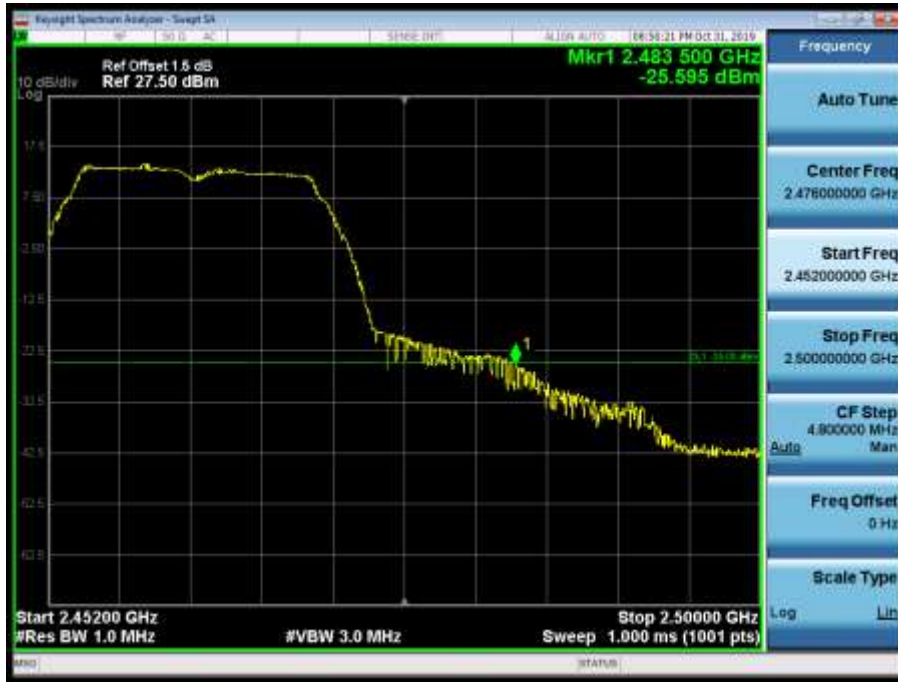

2412MHz by 802.11n(20MHz):

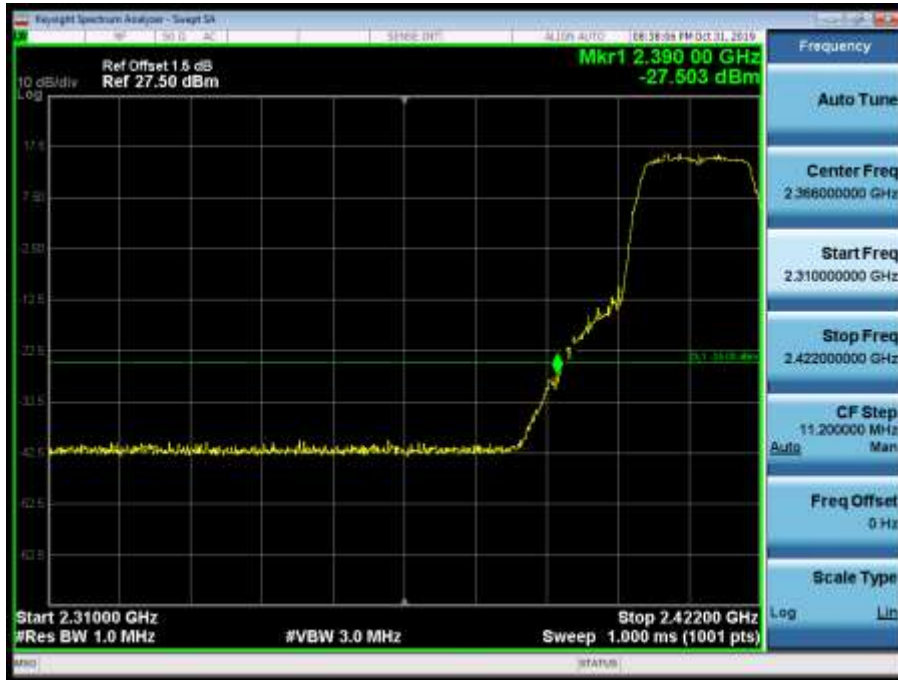

2417MHz by 802.11n(20MHz):

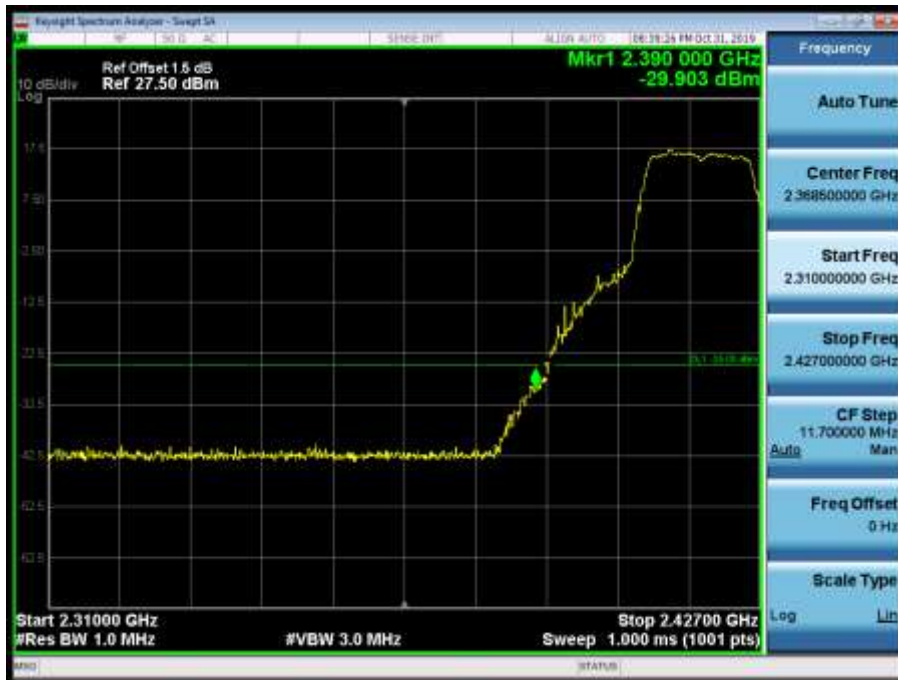

2437MHz by 802.11n(20MHz):

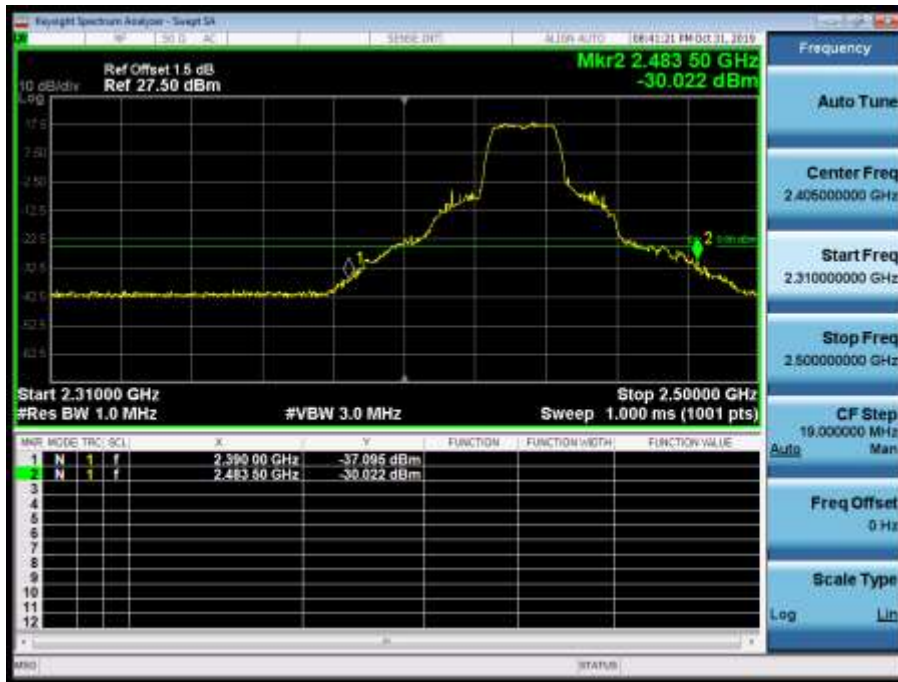

2457MHz by 802.11n(20MHz):



2462MHz by 802.11n(20MHz):



2412MHz by 802.11ax(20MHz):



2417MHz by 802.11ax(20MHz):

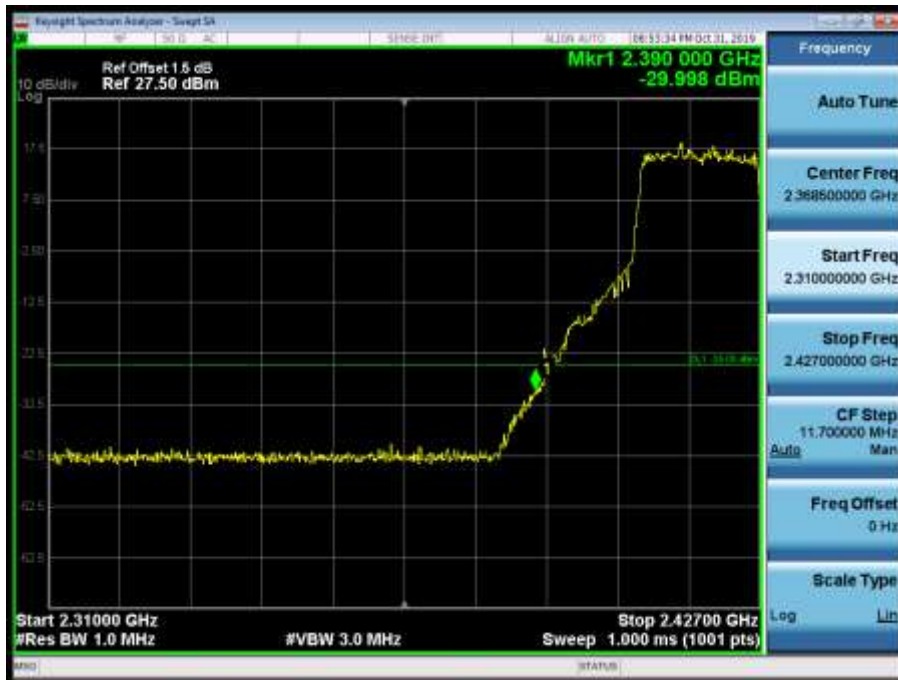

2437MHz by 802.11ax(20MHz):

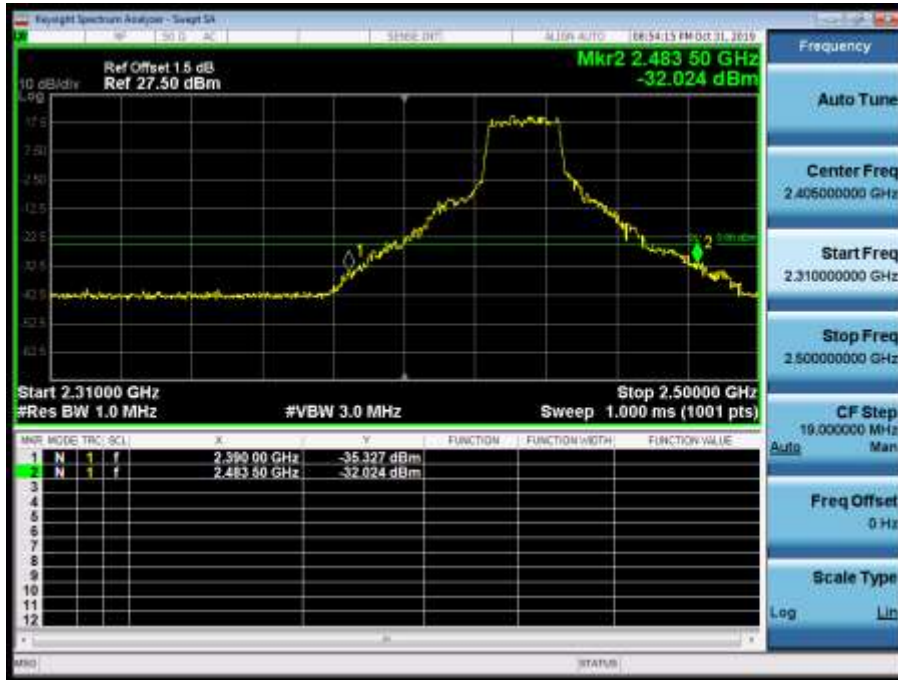

2457MHz by 802.11ax(20MHz):



2462MHz by 802.11ax(20MHz):



Radio 2

AV Limit-CDD:

2412MHz by 802.11b:

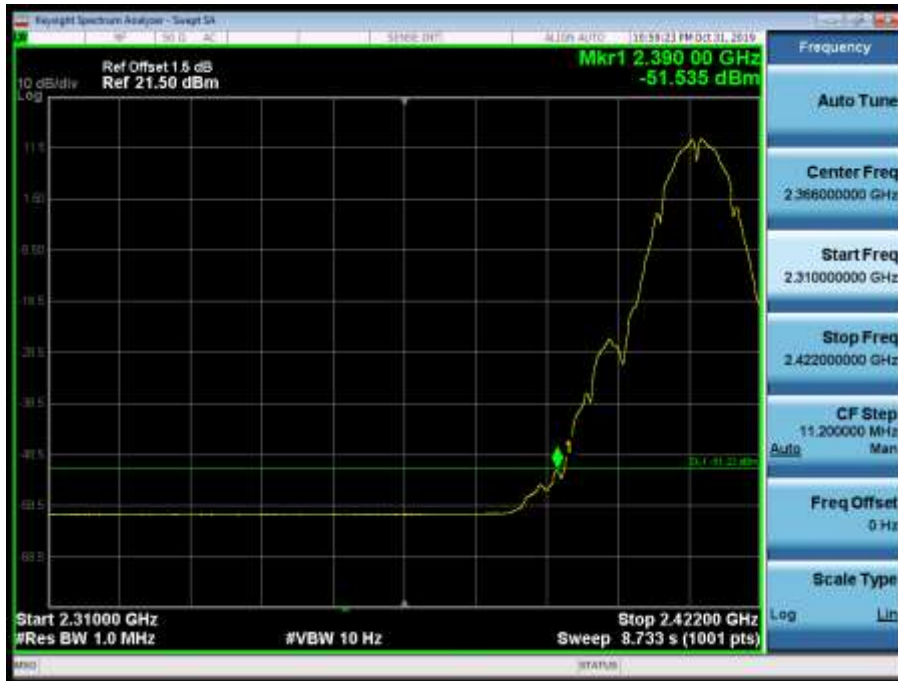

2417MHz by 802.11b:

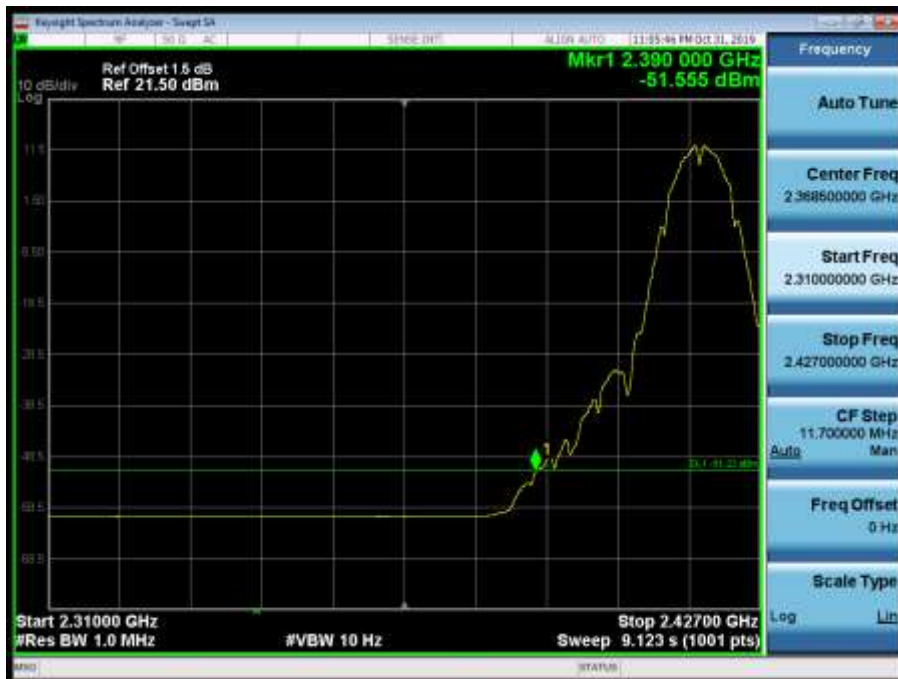

2437MHz by 802.11b:



2457MHz by 802.11b:

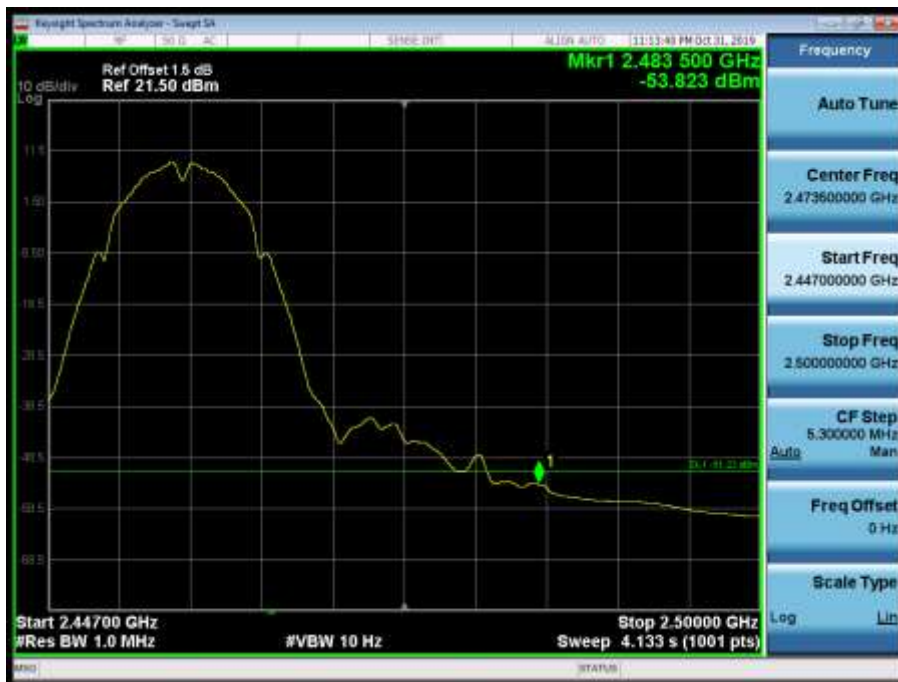

2462MHz by 802.11b:

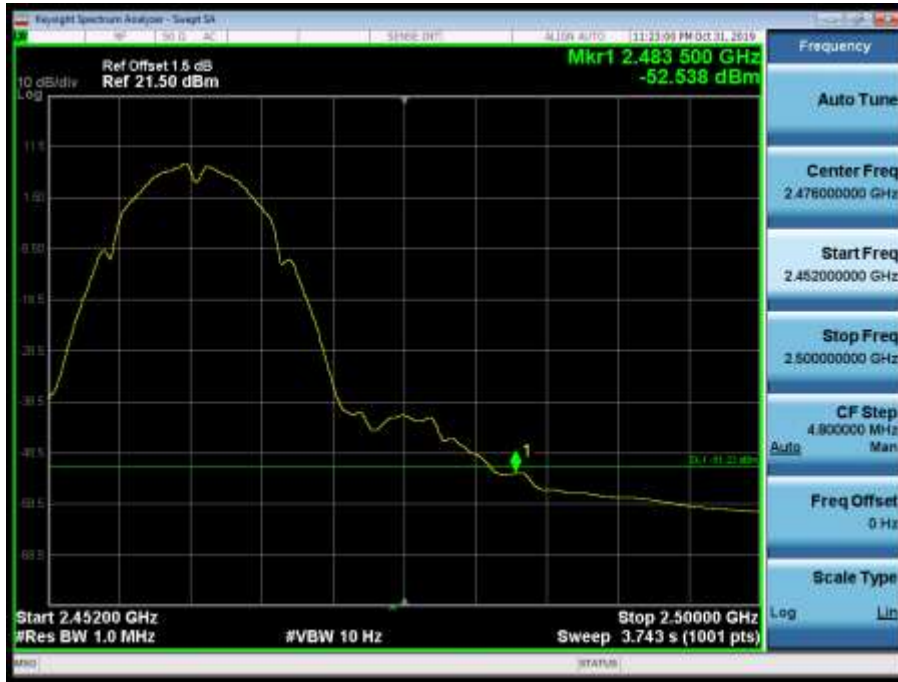

2412MHz by 802.11g:

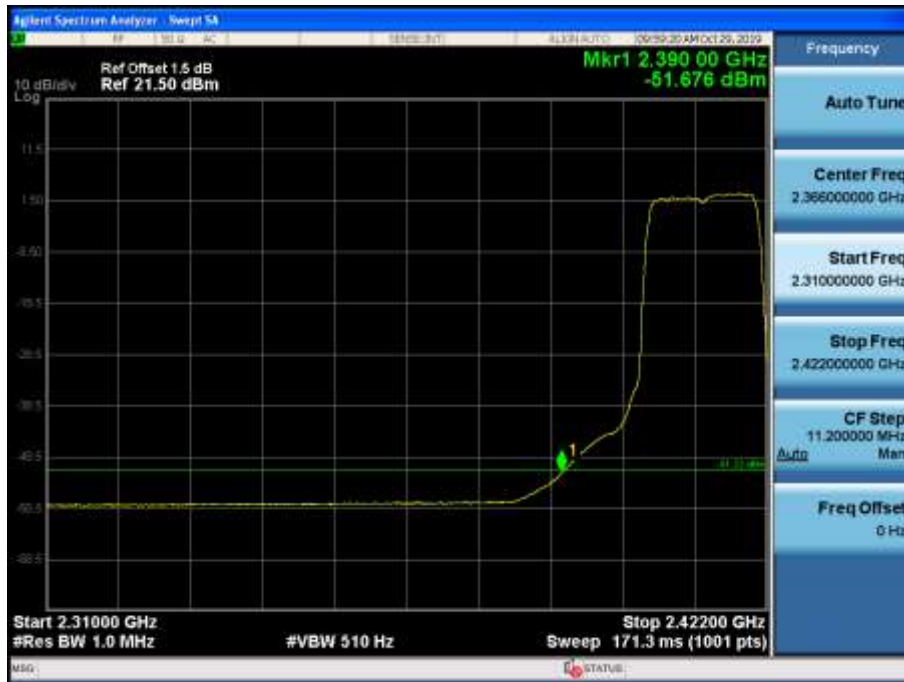

2417MHz by 802.11g:

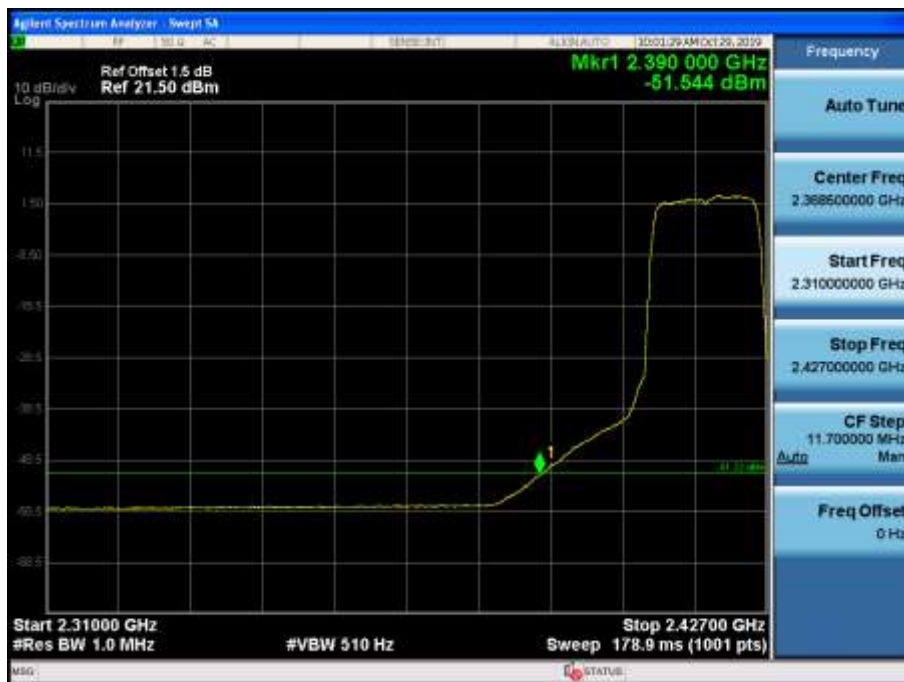

2437MHz by 802.11g:

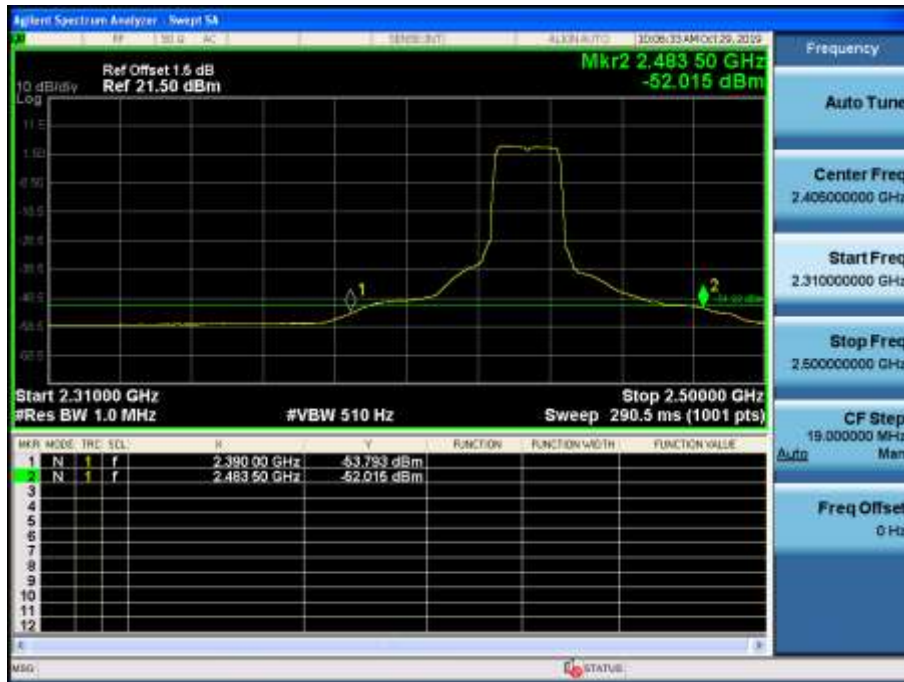

2457MHz by 802.11g:

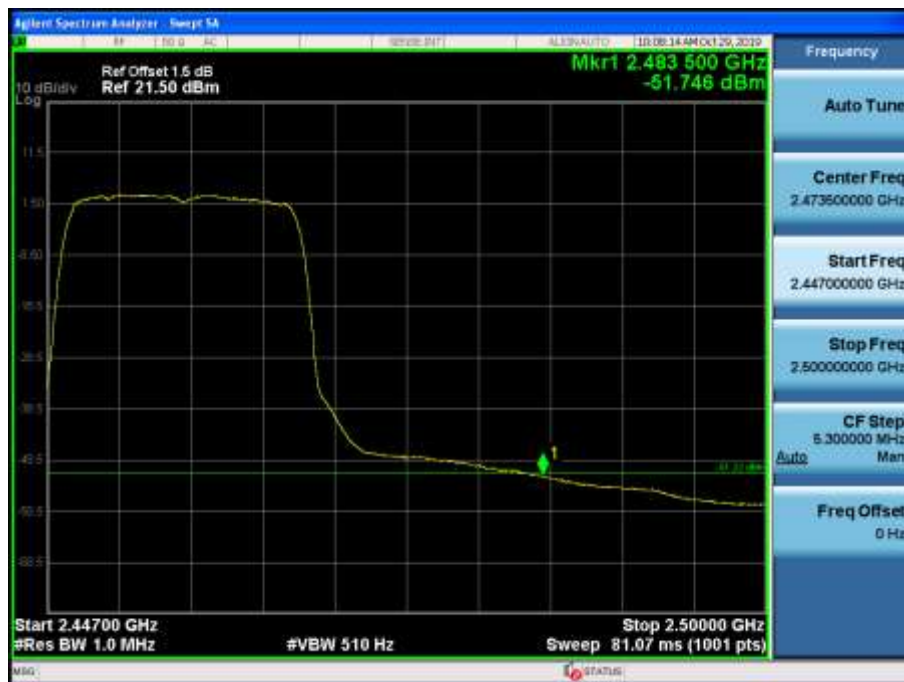

2462MHz by 802.11g:



2412MHz by 802.11n(20MHz):



2417MHz by 802.11n(20MHz):

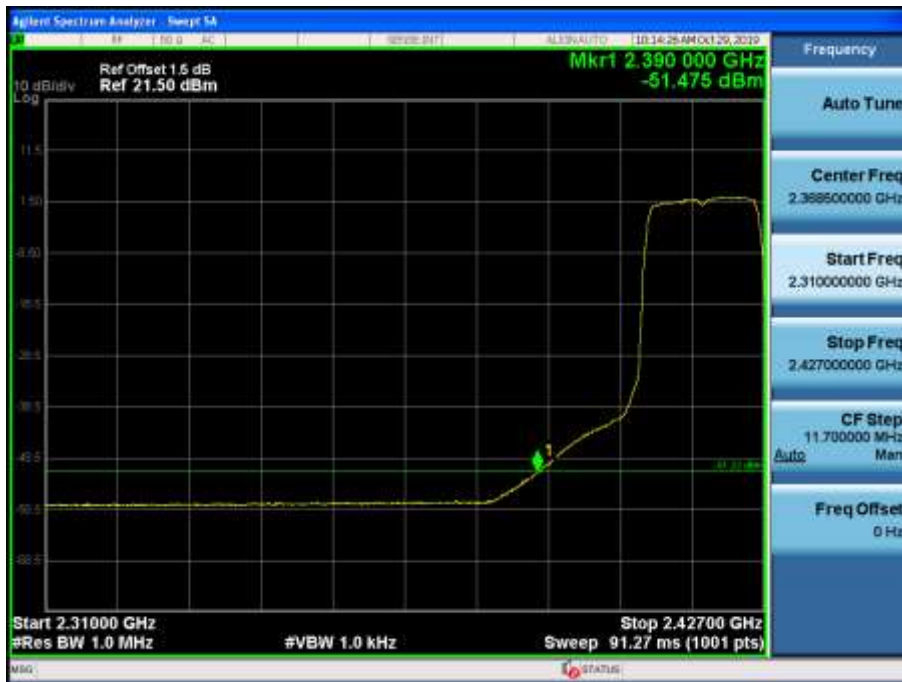

2437MHz by 802.11n(20MHz):

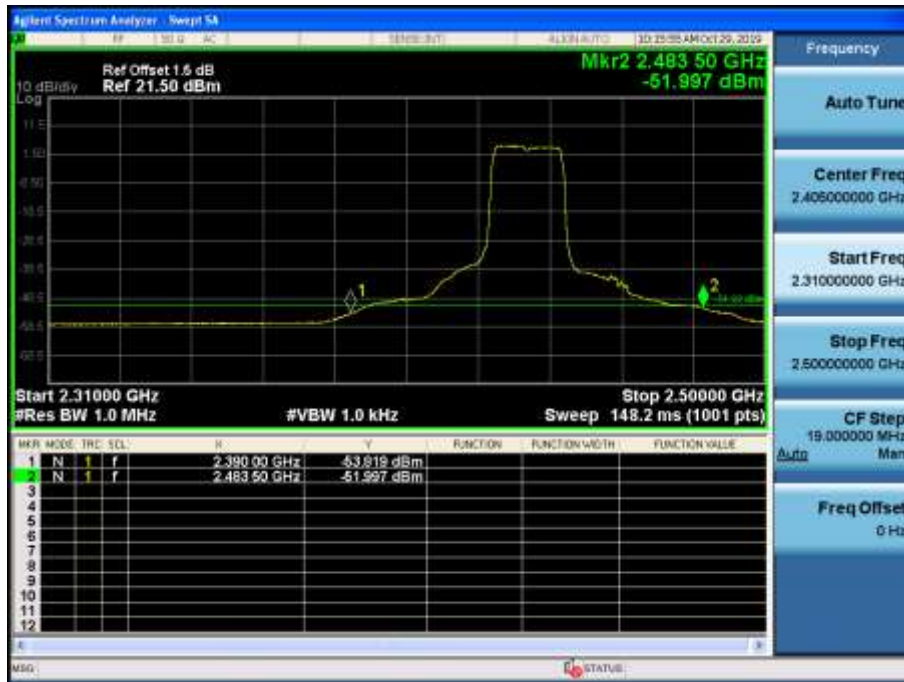

2457MHz by 802.11n(20MHz):

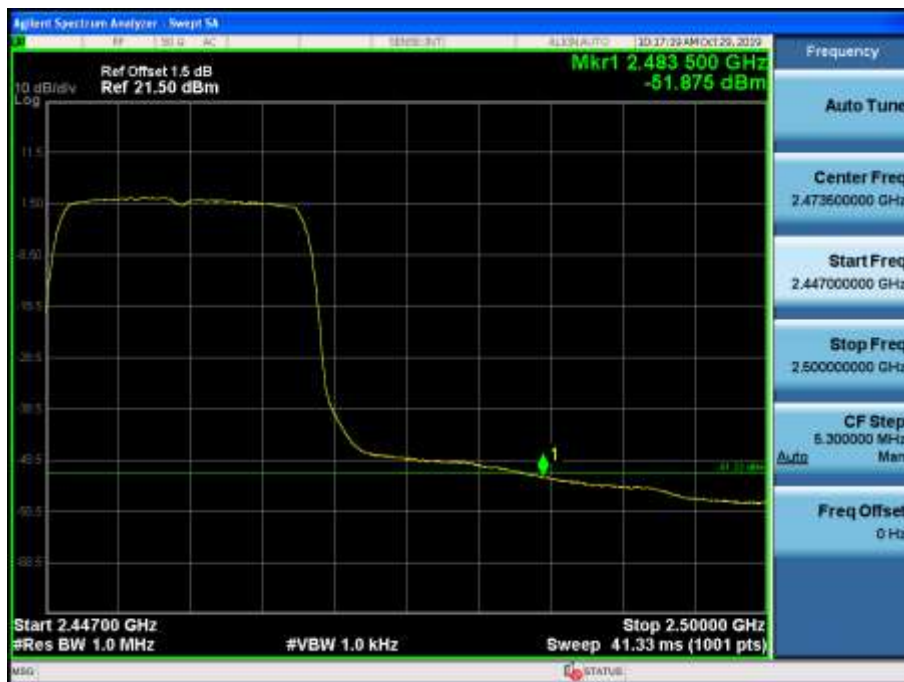

2462MHz by 802.11n(20MHz):



2412MHz by 802.11ax(20MHz):

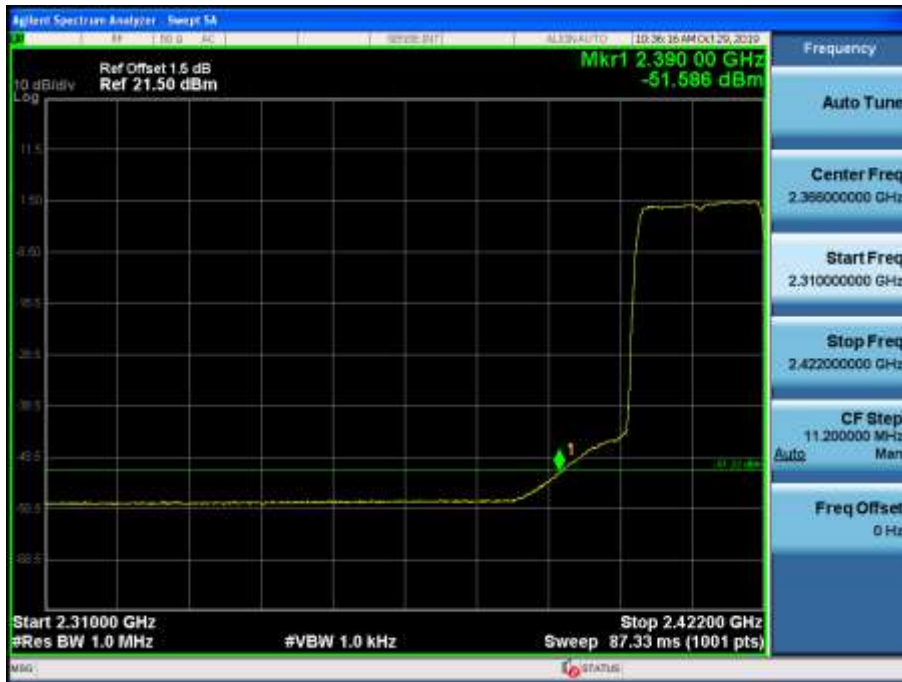

2417MHz by 802.11ax(20MHz):

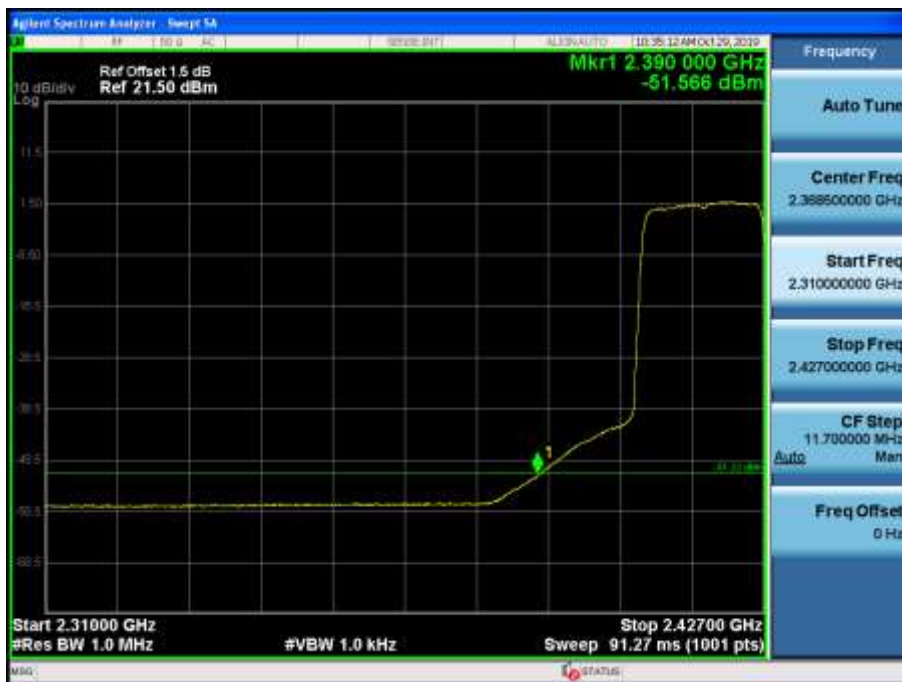

2437MHz by 802.11ax(20MHz):



2457MHz by 802.11ax(20MHz):

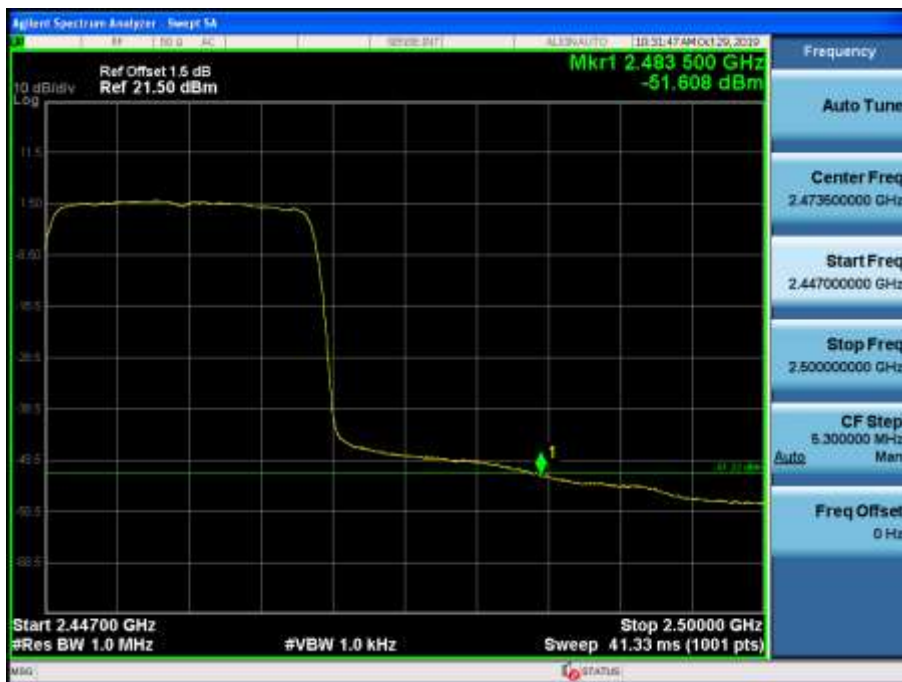

2462MHz by 802.11ax(20MHz):

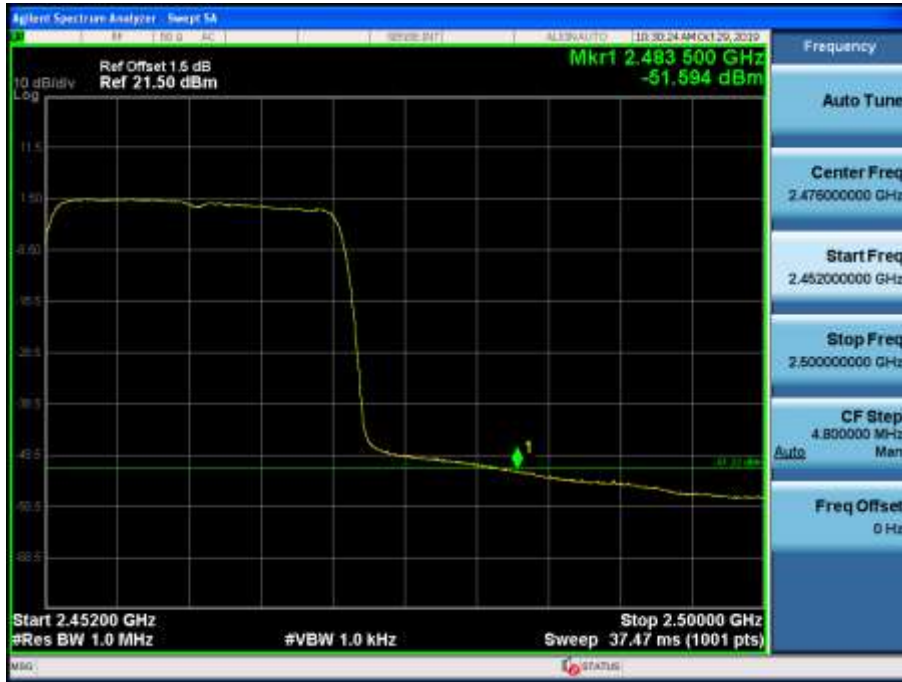

PK Limit-CDD:

2412MHz by 802.11b:

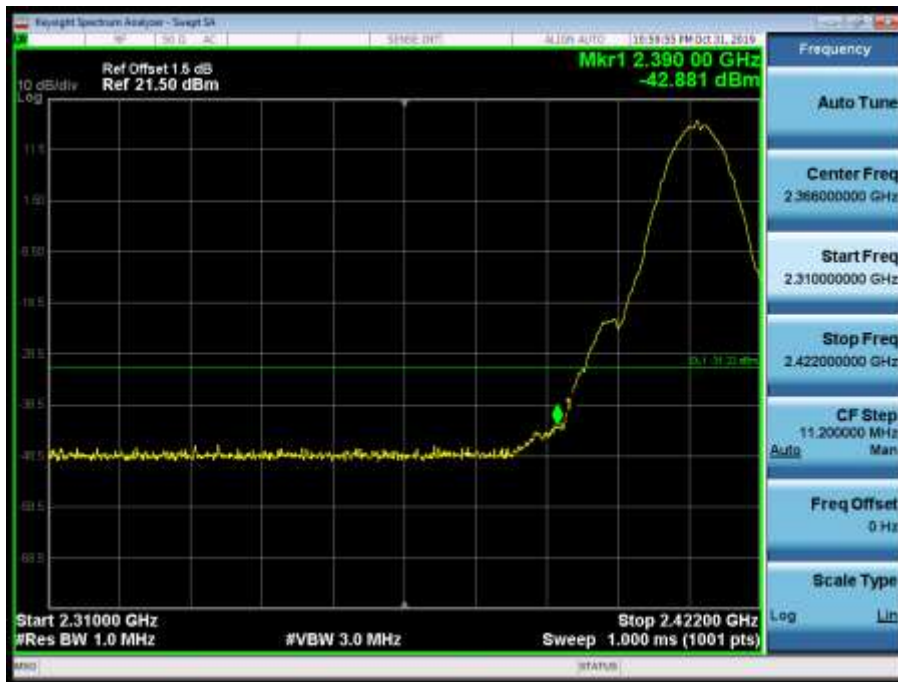

2417MHz by 802.11b:

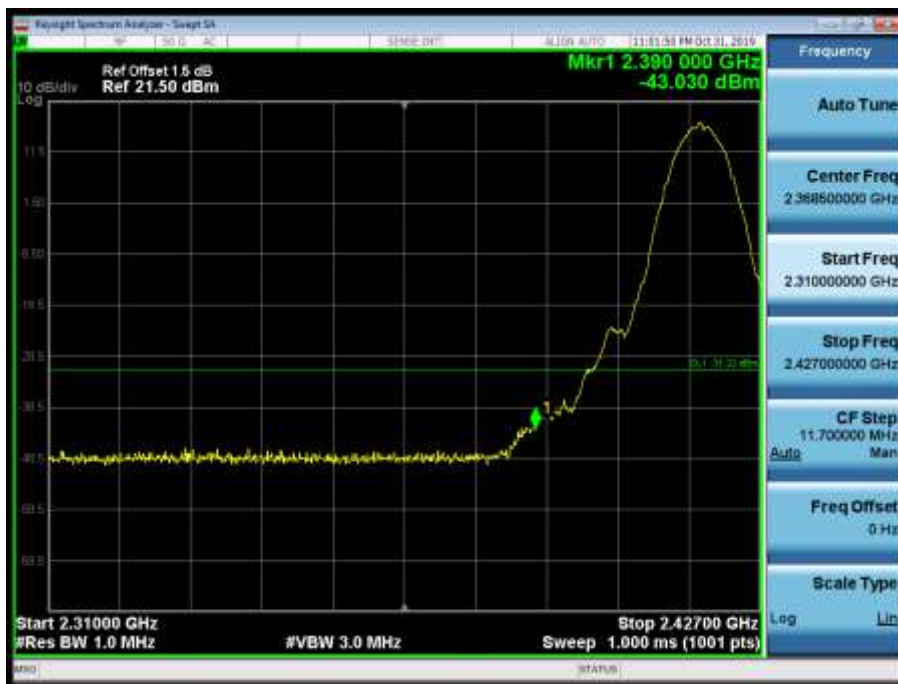

2437MHz by 802.11b:

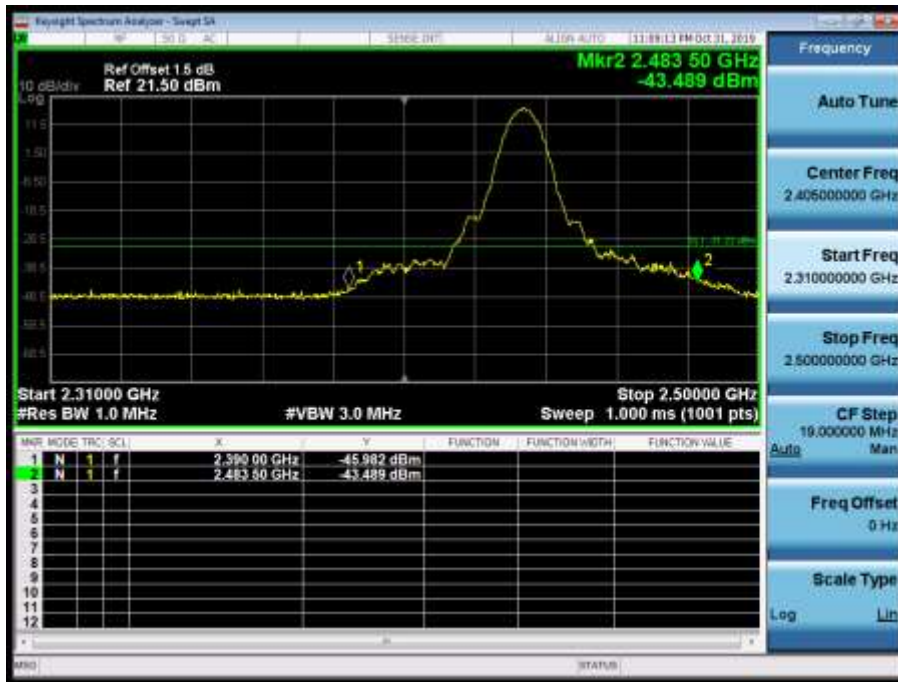

2457MHz by 802.11b:

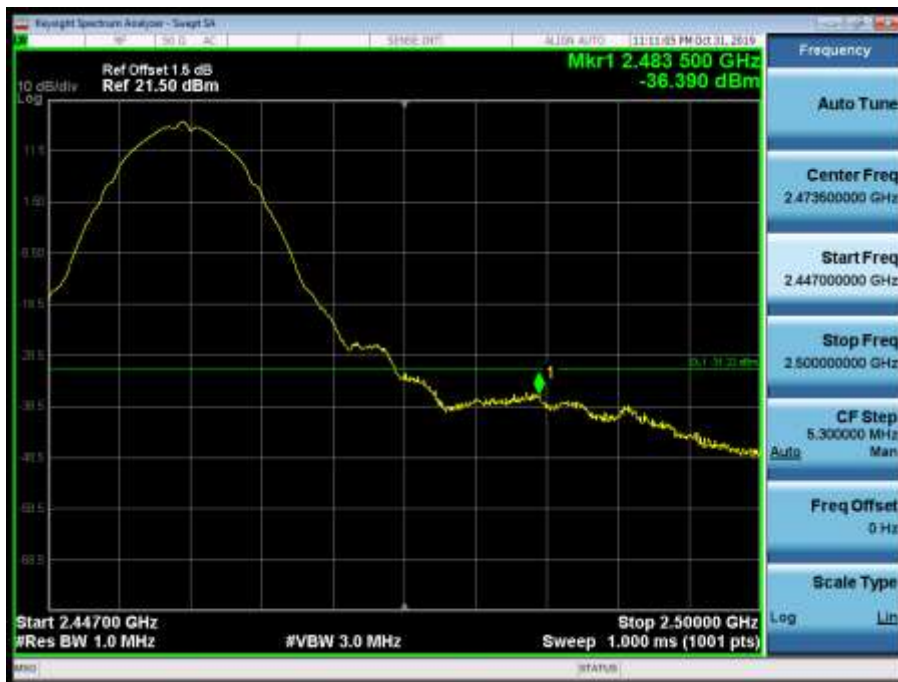

2462MHz by 802.11b:

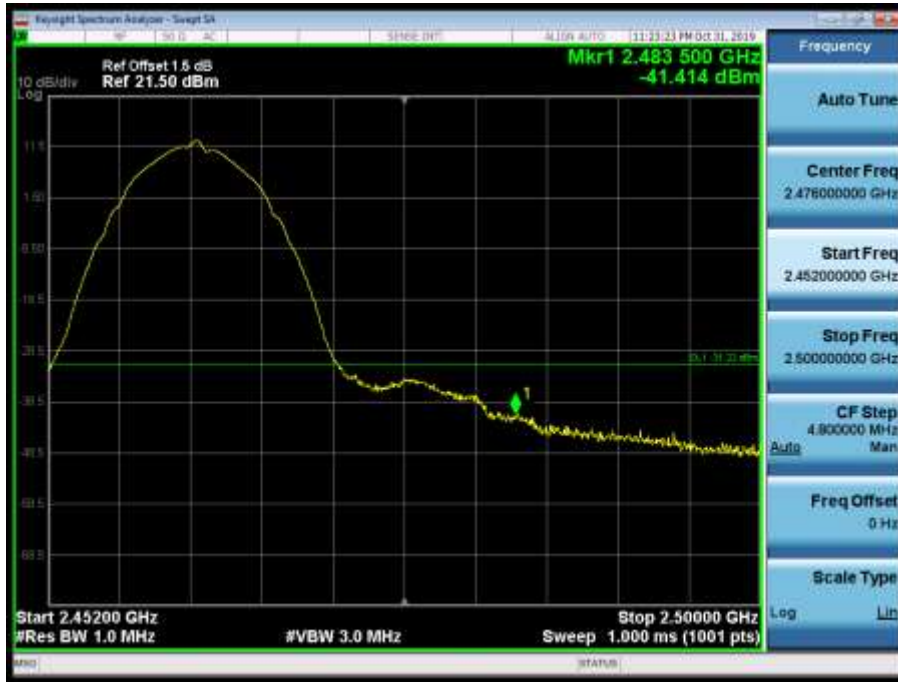

2412MHz by 802.11g:

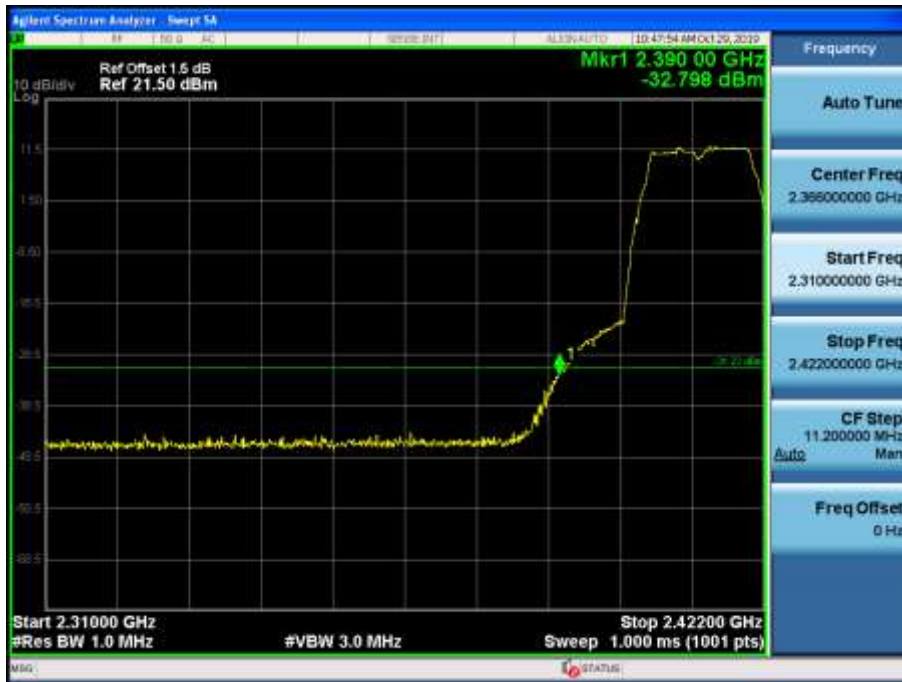

2417MHz by 802.11g:

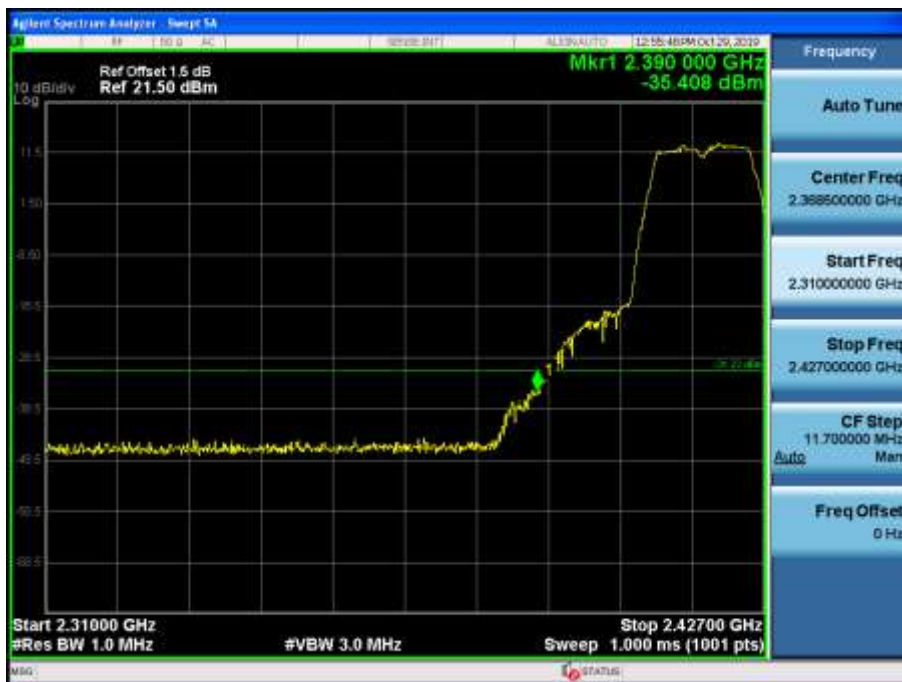

2437MHz by 802.11g:



2457MHz by 802.11g:



2462MHz by 802.11g:



2412MHz by 802.11n(20MHz):

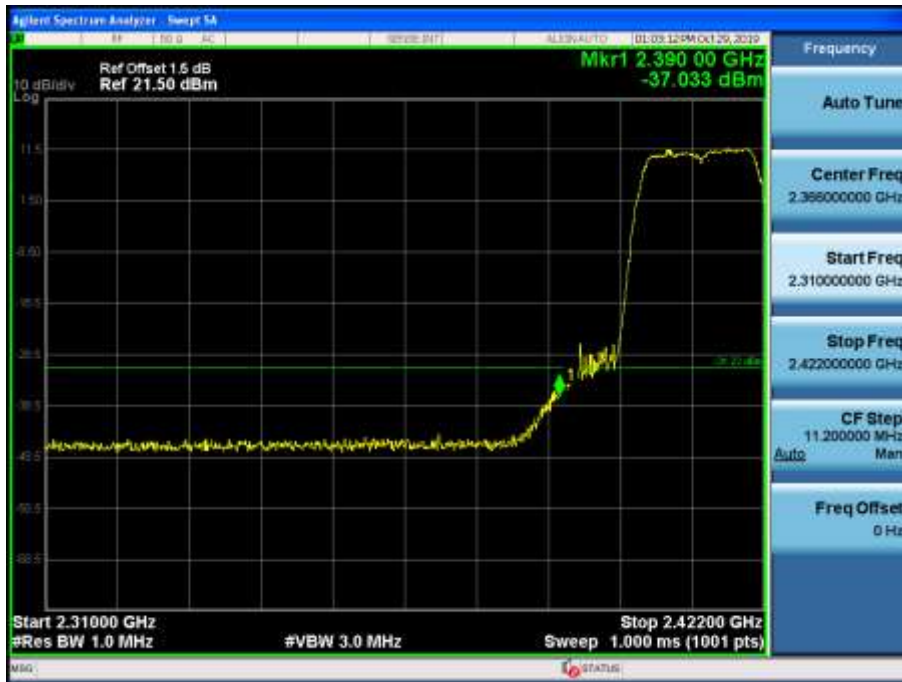

2417MHz by 802.11n(20MHz):

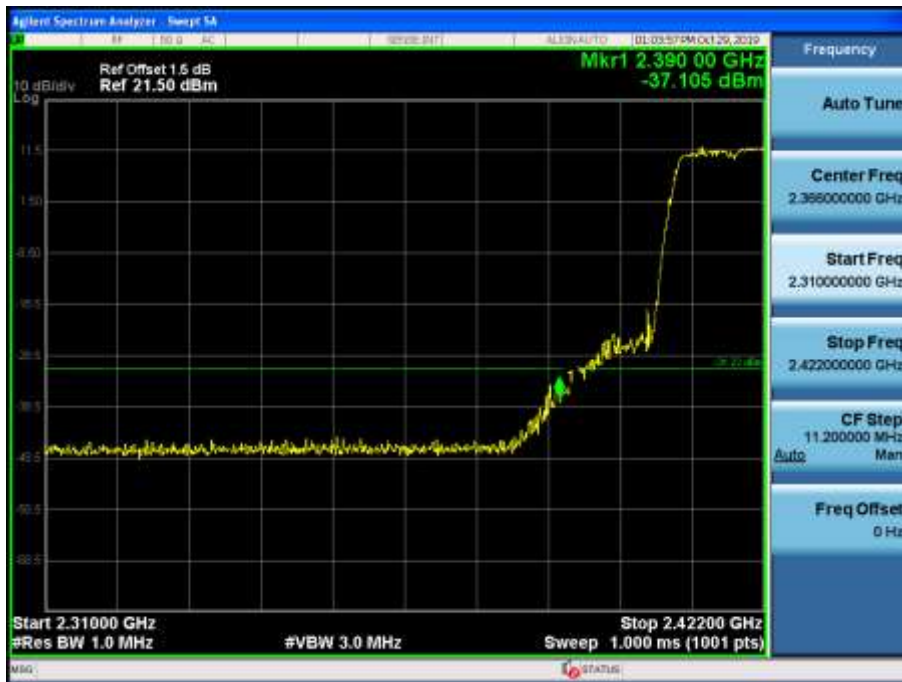

2437MHz by 802.11n(20MHz):



2457MHz by 802.11n(20MHz):

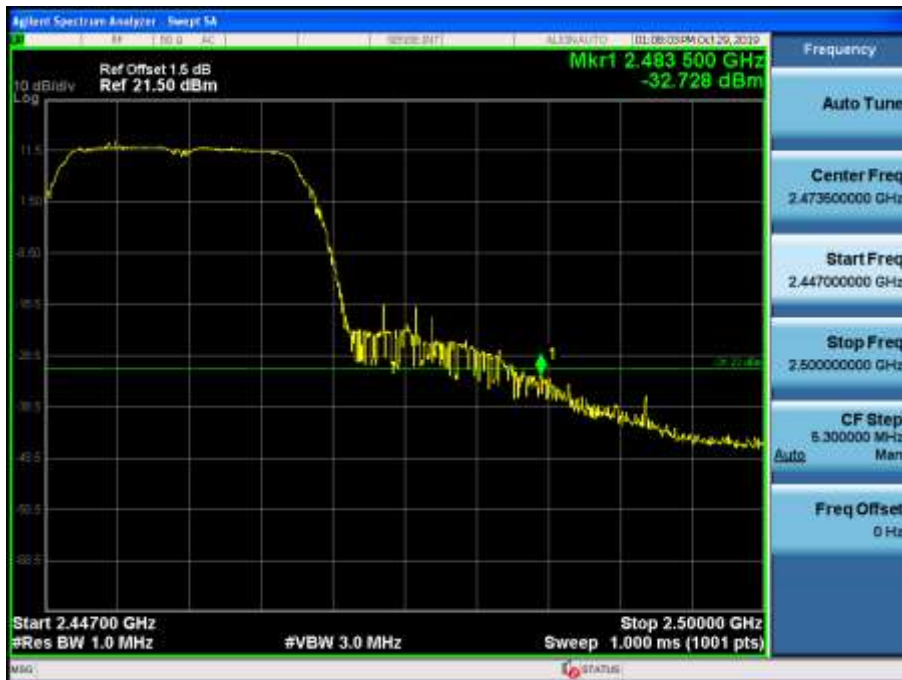

2462MHz by 802.11n(20MHz):



2412MHz by 802.11ax(20MHz):



2417MHz by 802.11ax(20MHz):

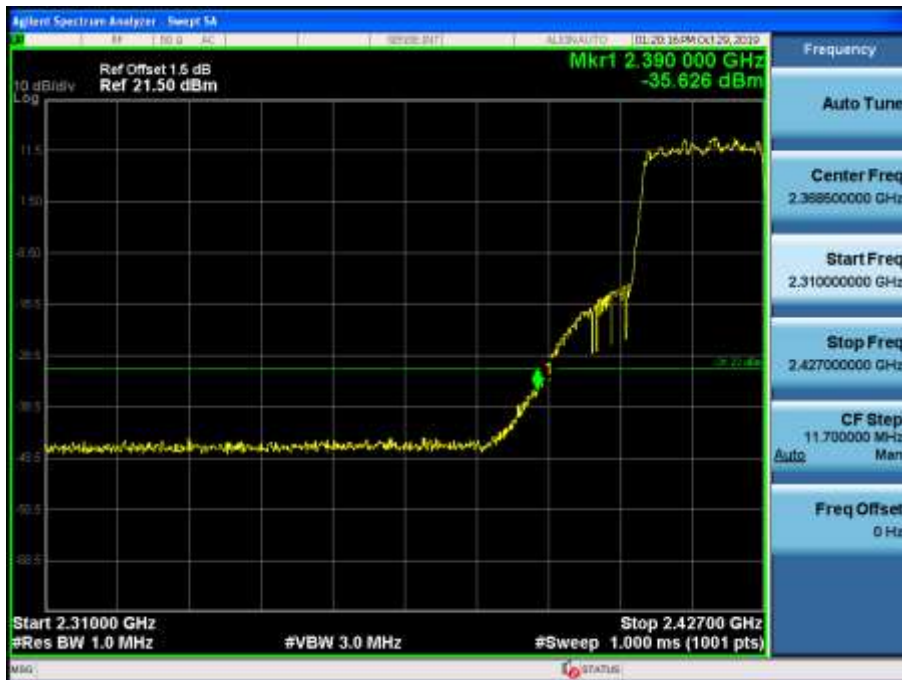

2437MHz by 802.11ax(20MHz):



2457MHz by 802.11ax(20MHz):



2462MHz by 802.11ax(20MHz):



**AV Limit-Beamforming:
2412MHz by 802.11n(20MHz):**

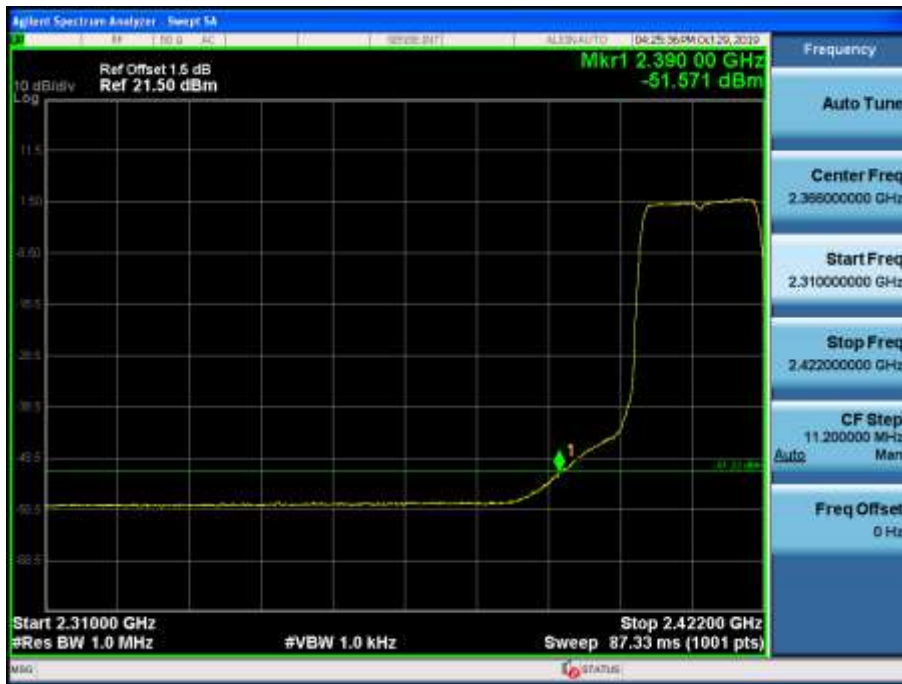

2417MHz by 802.11n(20MHz):

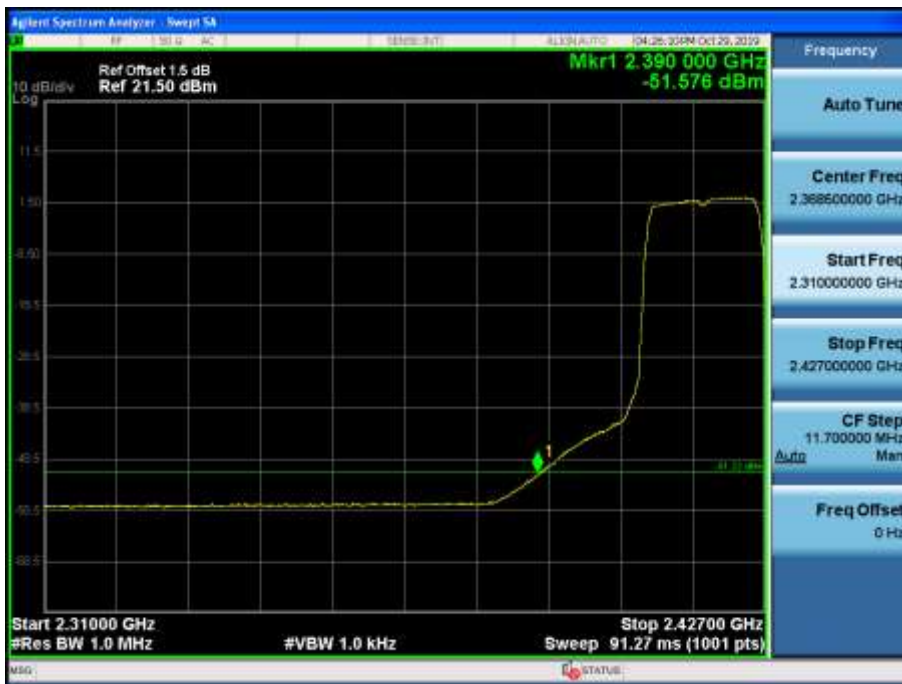

2437MHz by 802.11n(20MHz):

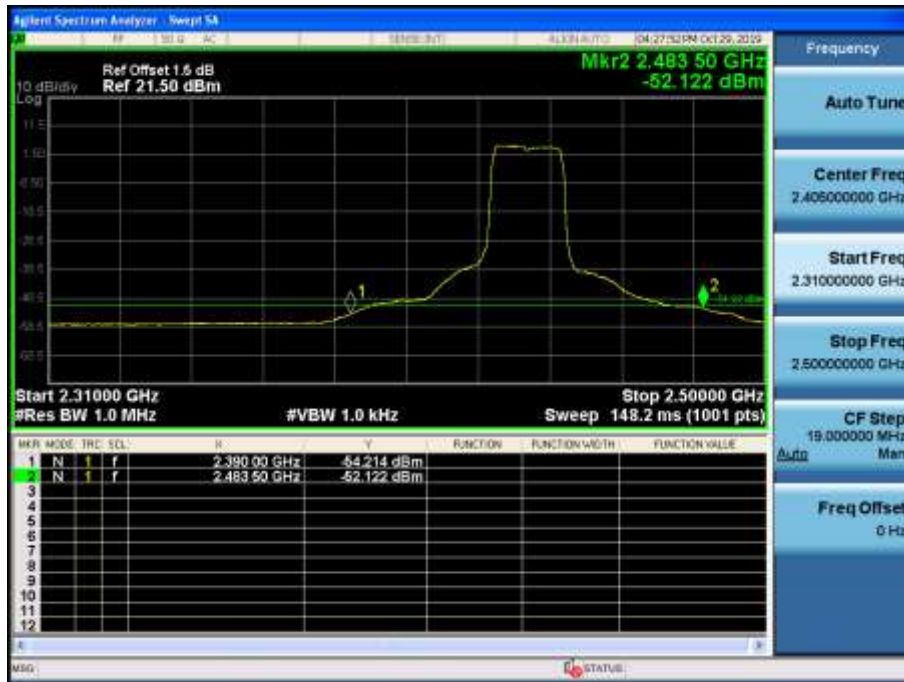

2457MHz by 802.11n(20MHz):

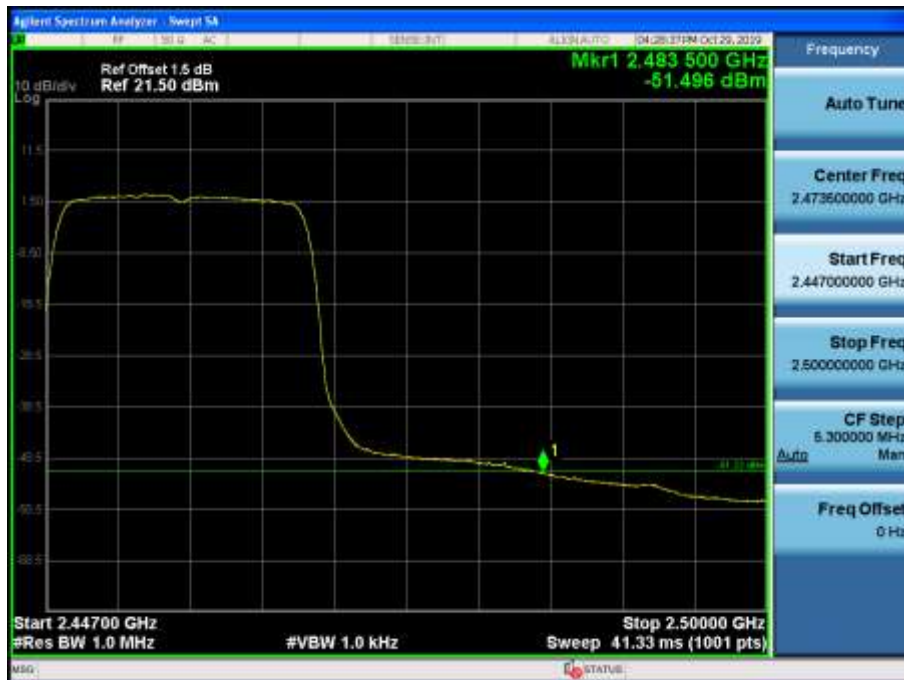

2462MHz by 802.11n(20MHz):



2412MHz by 802.11ax(20MHz):

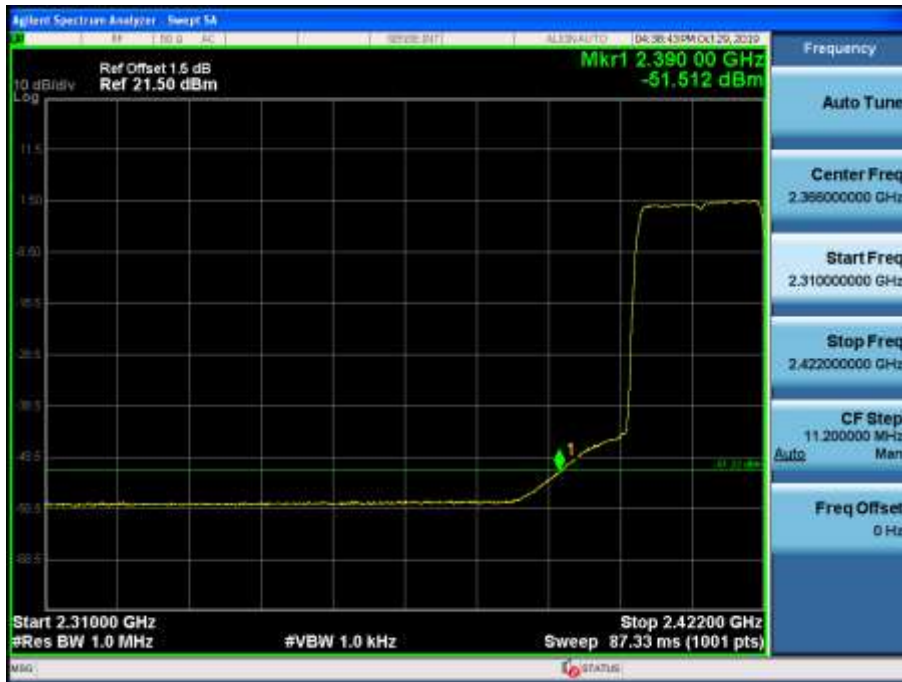

2417MHz by 802.11ax(20MHz):

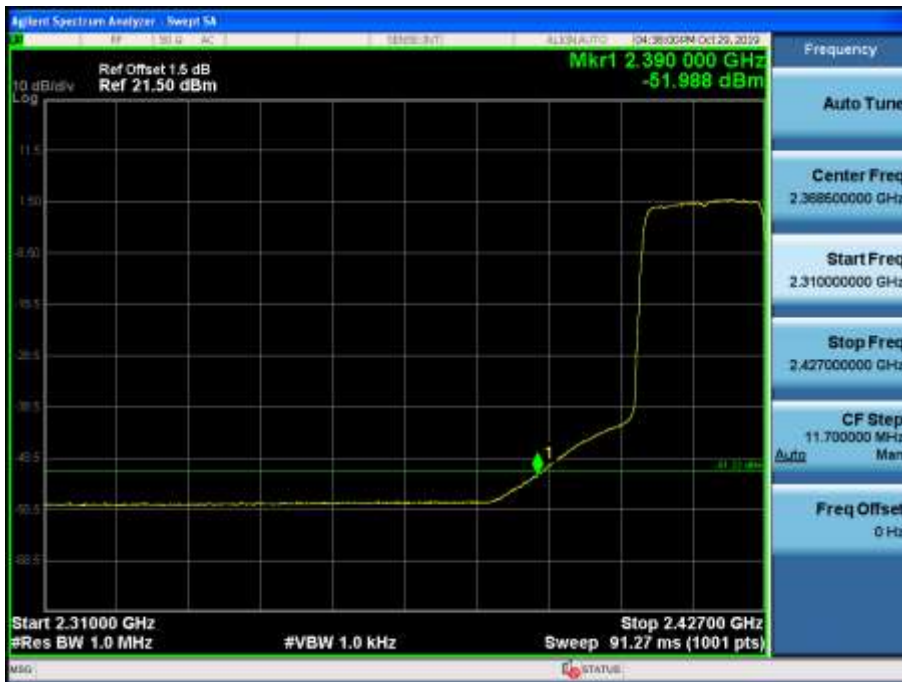

2437MHz by 802.11ax(20MHz):



2457MHz by 802.11ax(20MHz):

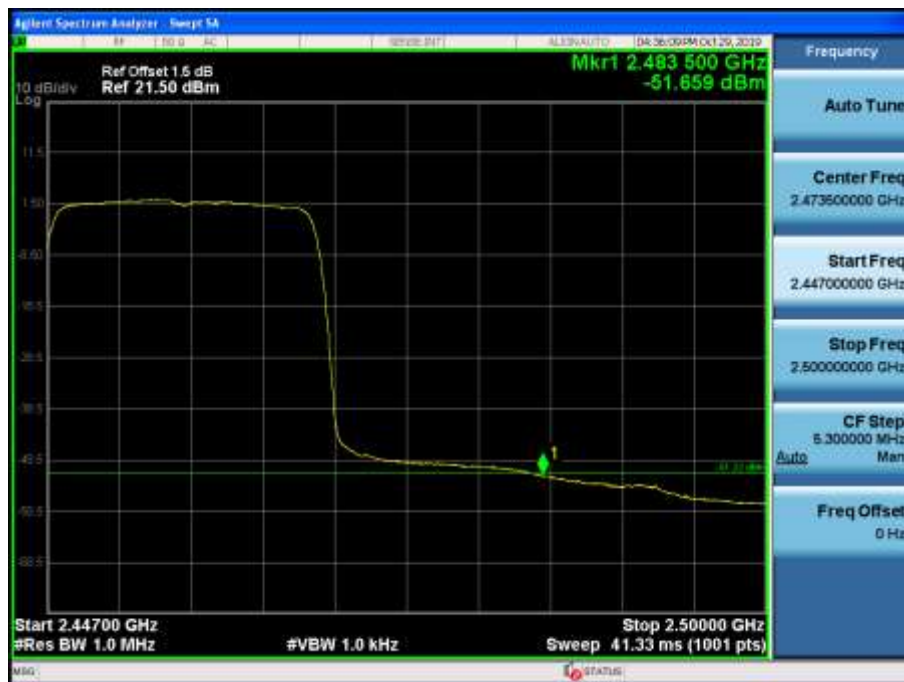

2462MHz by 802.11ax(20MHz):

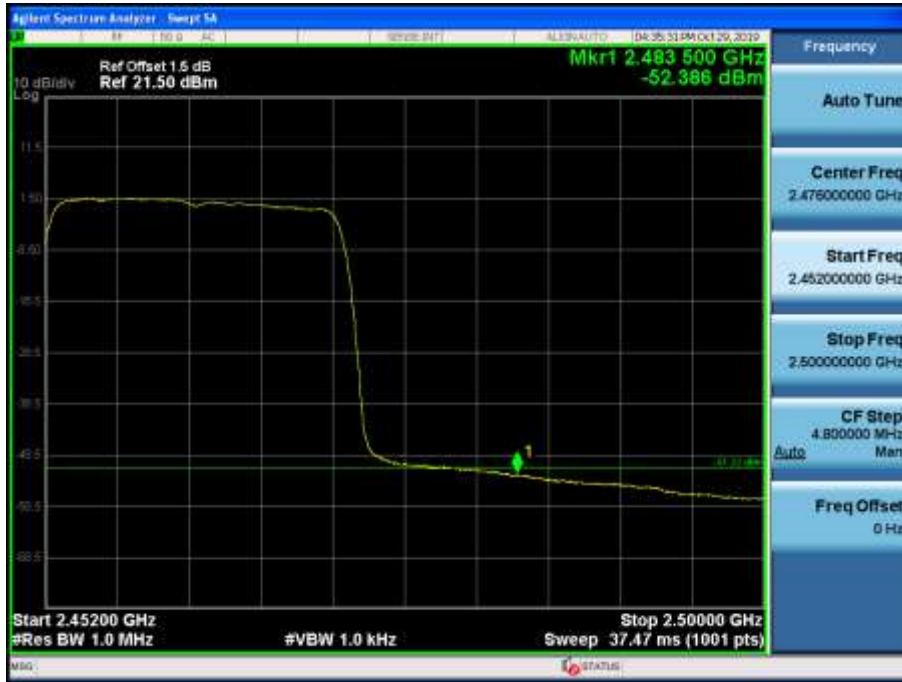

PK Limit-Beamforming

2412MHz by 802.11n(20MHz):

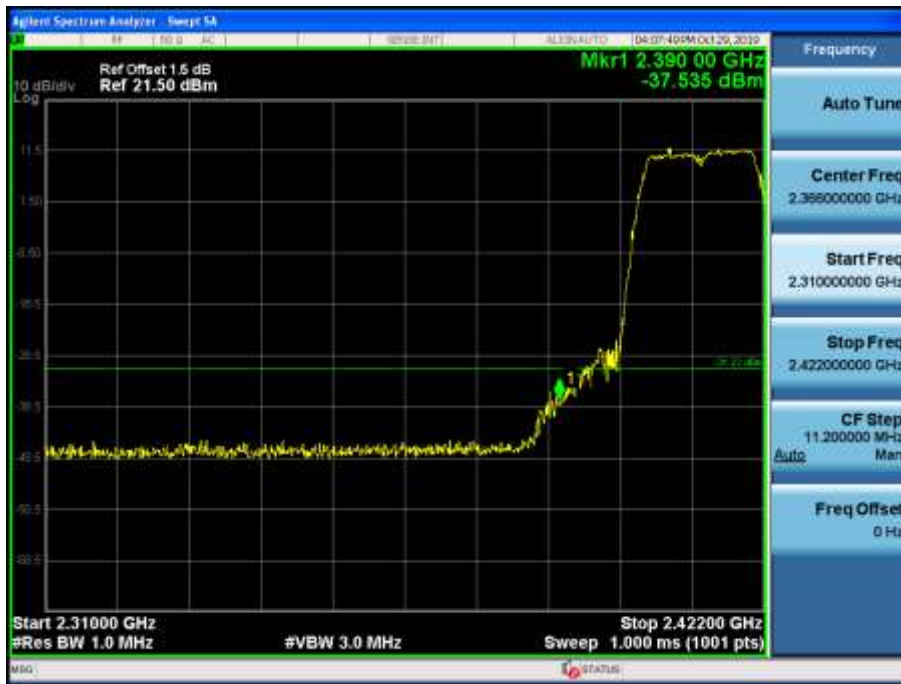

2417MHz by 802.11n(20MHz):



2437MHz by 802.11n(20MHz):

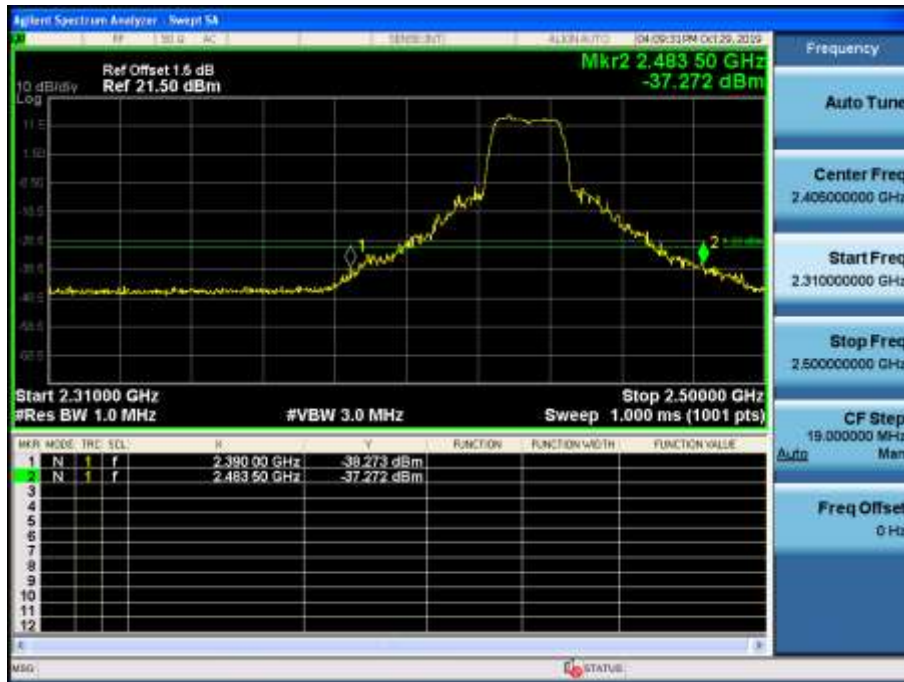

2457MHz by 802.11n(20MHz):



2462MHz by 802.11n(20MHz):



2412MHz by 802.11ax(20MHz):



2417MHz by 802.11ax(20MHz):



2437MHz by 802.11ax(20MHz):



2457MHz by 802.11ax(20MHz):



2462MHz by 802.11ax(20MHz):



7. Occupied Bandwidth

7.1. Test Equipment

Occupied Bandwidth / TR-8					
Instrument	Manufacturer	Type No.	Serial No.	Cal. Date	Cal. Due Date
Spectrum Analyzer	Agilent	N9010A	MY48030494	2020.02.04	2021.02.03
EXA Spectrum Analyzer	Keysight	N9010A	MY55370495	2019.04.09	2020.04.08
MXA Signal Analyzer	Keysight	N9020A	MY56060147	2019.04.09	2020.04.08
Temperature/Humidity Meter	zhichen	ZC1-2	TR8-TH	2019.04.10	2020.04.09

Note: All equipment are calibrated with traceable calibrations. Each calibration is traceable to the national or international standards.

7.2. Test Setup

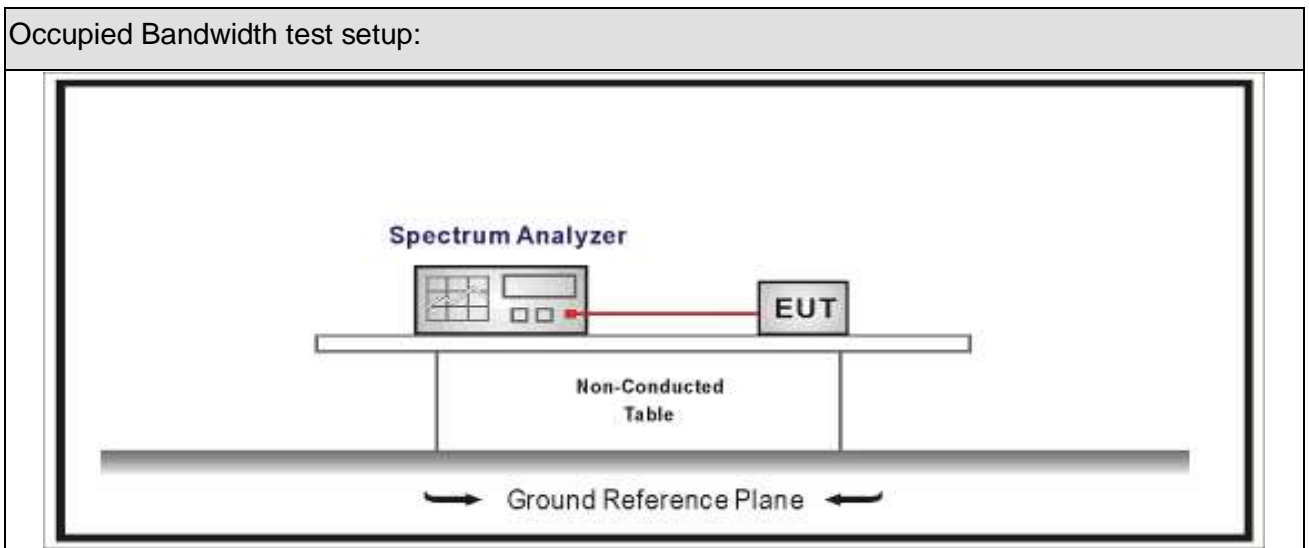





7.3. Limit

Occupied Bandwidth
Systems using digital modulation techniques operate in the 2400-2483.5 MHz. The minimum 6 dB bandwidth shall be at least 500 kHz

7.4. Test Procedure

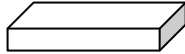
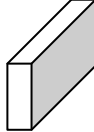
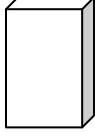
Test Method			
	Reference Rule	Chapter	Description
<input checked="" type="checkbox"/>	ANSI C63.10	11.8	DTS bandwidth
	<input type="checkbox"/> ANSI C63.10	11.8.1	Option 1
	<input checked="" type="checkbox"/> ANSI C63.10	11.8.2	Option 2

7.5. EUT test definition

Item	Occupied Bandwidth			
Device Category	<input type="checkbox"/>	Fixed point-to-point		
	<input type="checkbox"/>	Emit multiple directional beams, simultaneously or sequentially		
	<input checked="" type="checkbox"/>	Other cases		
Test mode	Mode 1~4			
Test method	<input type="checkbox"/>	Radiated		
		X Axis	Y Axis	Z Axis
				
		Worst Axis <input type="checkbox"/>	Worst Axis <input type="checkbox"/>	Worst Axis <input type="checkbox"/>
	<input checked="" type="checkbox"/>	Conducted		
	<input checked="" type="checkbox"/>	Chain 1		
				
	<input checked="" type="checkbox"/>	Chain 1	Chain 2	
				
	<input type="checkbox"/>	Chain 1	Chain 2	Chain 3
				

7.6. Test Result

Product Name	: Wireless Access Point	Power	: AC 120V/60Hz
Test Mode	: Mode 1~4	Test Site	: TR8
Test Date	: 2019.11.19	Test Engineer	: Eric

Mode	CH.	Test Freq. (MHz)	99% Occupied Bandwidth (MHz)	6dB Occupied Bandwidth (MHz)	Limit (kHz)	Result
1	01	2412	13.265	7.583	>500	Pass
1	06	2437	13.569	7.555	>500	Pass
1	11	2462	13.583	7.087	>500	Pass
2	01	2412	17.551	16.35	>500	Pass
2	06	2437	17.439	16.39	>500	Pass
2	11	2462	17.393	16.39	>500	Pass
3	01	2412	18.517	17.57	>500	Pass
3	06	2437	18.539	17.64	>500	Pass
3	11	2462	18.446	17.59	>500	Pass
4	01	2412	19.193	18.83	>500	Pass
4	06	2437	19.194	19.02	>500	Pass
4	11	2462	19.171	18.97	>500	Pass

Note : The worst case of Occupied Bandwidth as below in next page:

Mode 1 CH11 (2462MHz)



8. Fundamental emission output power

8.1. Test Equipment

Fundamental emission output power/ TR-8					
Instrument	Manufacturer	Type No.	Serial No.	Cal. Date	Cal. Due Date
Spectrum Analyzer	Agilent	E4446A	MY45300103	2020.01.04	2021.01.03
Spectrum Analyzer	Agilent	N9010A	MY48030494	2020.02.04	2021.02.03
Wideband Peak Power Meter	Anritsu	ML2495A	0905006	2019.10.14	2020.10.13
Power Sensor	Anritsu	MA2411B	0846014	2019.10.14	2020.10.13
Temperature/Humidity Meter	zhicheng	ZC1-2	TR8-TH	2019.04.10	2020.04.09

Note: All equipment are calibrated with traceable calibrations. Each calibration is traceable to the national or international standards.

8.2. Test Setup

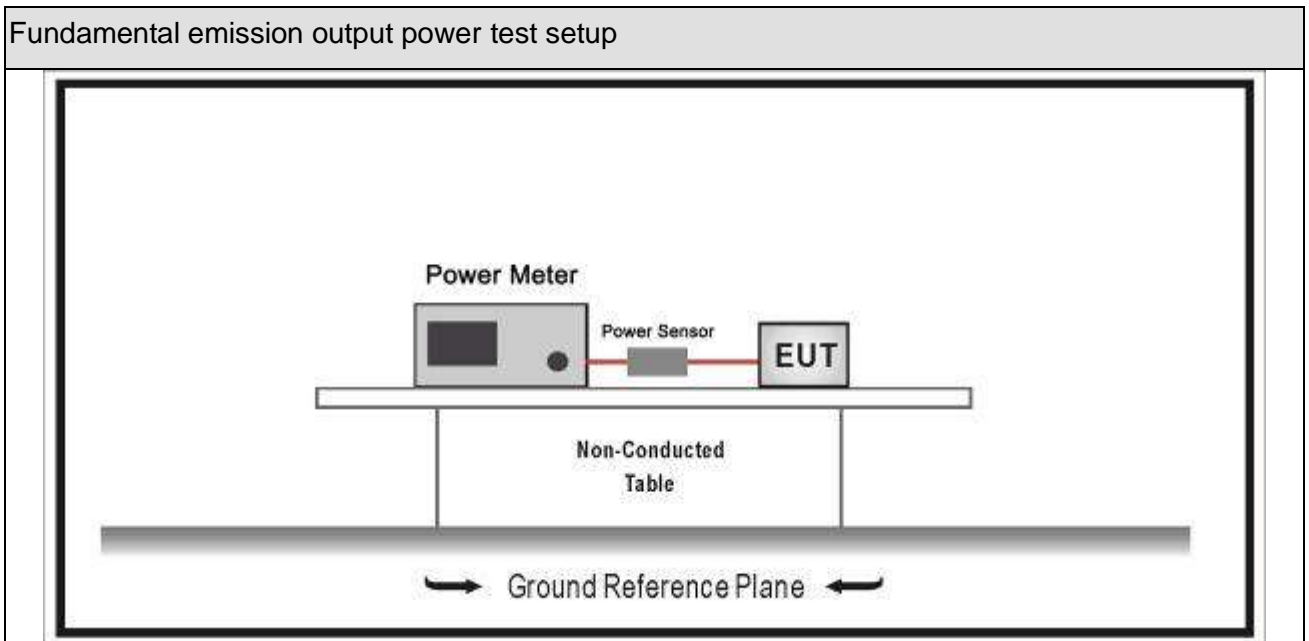

8.3. Limit





Fundamental emission output power Limit		
<input checked="" type="checkbox"/>	$G_{TX} < 6\text{dBi}$	$P_{out} \leq 30\text{dBm}$
<input checked="" type="checkbox"/>	$G_{TX} > 6\text{dBi}$	
<input checked="" type="checkbox"/>	Non-Fix point-point	$P_{out} \leq 30 - (G_{TX} - 6)$
<input type="checkbox"/>	Fix point-point	$P_{out} \leq 30 - [(G_{TX} - 6)]/3$
<input type="checkbox"/>	Point-to-multipoint	$P_{out} \leq 30 - (G_{TX} - 6)$
<input type="checkbox"/>	Overlap Beams	$P_{out} \leq 30 - [(G_{TX} - 6)]/3$
<input type="checkbox"/>	Aggregate power transmitted simultaneously on all beams	$P_{out} \leq 30 - [(G_{TX} - 6)]/3$
<input type="checkbox"/>	single directional beam	$P_{out} \leq 30 - [(G_{TX} - 6)]/3 + 8\text{dB}$
Note 1 : G_{TX} directional gain of transmitting antennas.		
Note 2 : P_{out} is maximum peak conducted output power .		

8.4. Test Procedure

Fundamental emission output power Test Method						
	References Rule		Chapter	Description		
<input checked="" type="checkbox"/>	ANSI C63.10		11.9	Fundamental emission output power		
	<input type="checkbox"/>	ANSI C63.10		11.9.1	Maximum peak conducted output power	
		<input type="checkbox"/>	ANSI C63.10	11.9.1.1	RBW \geq DTS bandwidth	
		<input type="checkbox"/>	ANSI C63.10	11.9.1.2	Integrated band power method	
		<input type="checkbox"/>	ANSI C63.10	11.9.1.3	PKPM1 Peak power meter method	
	<input checked="" type="checkbox"/>	ANSI C63.10		11.9.2	Maximum conducted (average) output power	
		<input type="checkbox"/>	ANSI C63.10		11.9.2.2	Measurement using a spectrum analyzer (SA)
			<input type="checkbox"/>	ANSI C63.10	11.9.2.2.2	Method AVGSA-1(Duty cycle \geq 98%)
			<input type="checkbox"/>	ANSI C63.10	11.9.2.2.3	Method AVGSA-1A(Duty cycle \geq 98%)
			<input type="checkbox"/>	ANSI C63.10	11.9.2.2.4	Method AVGSA-2(Duty cycle \leq 98%)
			<input type="checkbox"/>	ANSI C63.10	11.9.2.2.5	Method AVGSA-2A(Duty cycle \leq 98%)
			<input type="checkbox"/>	ANSI C63.10	11.9.2.2.4	Method AVGSA-3
			<input type="checkbox"/>	ANSI C63.10	11.9.2.2.5	Method AVGSA-3A
		<input checked="" type="checkbox"/>	ANSI C63.10		11.9.2.3	Measurement using a power meter (PM)
		<input checked="" type="checkbox"/>	ANSI C63.10	11.9.2.3.1	Method AVGPM	
<input type="checkbox"/>		ANSI C63.10	11.9.2.3.2	Method AVGPM-G		

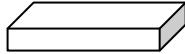
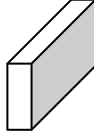
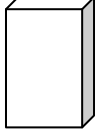
Directional Gain Calculations for In-Band test method			
	References Rule	Chapter	Description
<input type="checkbox"/>	KDB 662911	F2)a)	Basic methodology
	<input type="checkbox"/> KDB 662911	F2)a) (i)	transmit signals are correlated
	<input type="checkbox"/> KDB 662911	F2)a) (ii)	transmit signals are uncorrelated
<input type="checkbox"/>	KDB 662911	F2)b)	Sectorized antenna systems.
<input type="checkbox"/>	KDB 662911	F2)c)	Cross-polarized antennas
	<input type="checkbox"/> ANSI C63.10	F2)c) (i)	Cross-polarized antennas
	<input type="checkbox"/> ANSI C63.10	F2)c) (ii)	Multiple antennas
<input checked="" type="checkbox"/>	KDB 662911	F2)e)	Spatial Multiplexing
	<input type="checkbox"/> KDB 662911	F2)e) (i)	Antennas have the same gain
	<input type="checkbox"/> KDB 662911	F2)e) (ii)	Antenna have the different gain with one spatial stream
	<input checked="" type="checkbox"/> KDB 662911	F2)e) (iii)	Antenna have the different gain with more than one spatial stream
<input checked="" type="checkbox"/>	KDB 662911	F2)f)	Cyclic Delay Diversity (CDD)
	<input type="checkbox"/> KDB 662911	F2)f) (i)	Antennas have the same gain
	<input type="checkbox"/> KDB 662911	F2)f) (ii)	Antenna have the different gain with one spatial stream
	<input checked="" type="checkbox"/> KDB 662911	F2)f) (iii)	Antenna have the different gain with more than one spatial stream

8.5. EUT test definition

Item	Fundamental emission output power			
Device Category	<input type="checkbox"/>	Fixed point-to-point		
	<input type="checkbox"/>	Emit multiple directional beams, simultaneously or sequentially		
	<input checked="" type="checkbox"/>	Other cases		
Test mode	Mode 1~4			
Test method	<input type="checkbox"/>	Radiated		
		X Axis	Y Axis	Z Axis
				
		Worst Axis <input type="checkbox"/>	Worst Axis <input type="checkbox"/>	Worst Axis <input type="checkbox"/>
	<input checked="" type="checkbox"/>	Conducted		
	<input checked="" type="checkbox"/>	Chain 1		
				
	<input checked="" type="checkbox"/>	Chain 1	Chain 2	
				
	<input type="checkbox"/>	Chain 1	Chain 2	Chain 3
				

8.6. Test Result

Pass

The test data please refer to the files attached.

Appendix 2: 2.4GHz FCC RF output power

9. Power Spectral Density

9.1. Test Equipment

Power Spectral Density / TR-8					
Instrument	Manufacturer	Type No.	Serial No.	Cal. Date	Cal. Due Date
Spectrum Analyzer	Agilent	N9010A	MY48030494	2020.02.04	2021.02.03
EXA Spectrum Analyzer	Keysight	N9010A	MY55370495	2019.04.09	2020.04.08
MXA Signal Analyzer	Keysight	N9020A	MY56060147	2019.04.09	2020.04.08
Temperature/Humidity Meter	zhichen	ZC1-2	TR8-TH	2019.04.10	2020.04.09

Note: All equipment are calibrated with traceable calibrations. Each calibration is traceable to the national or international standards.

9.2. Test Setup

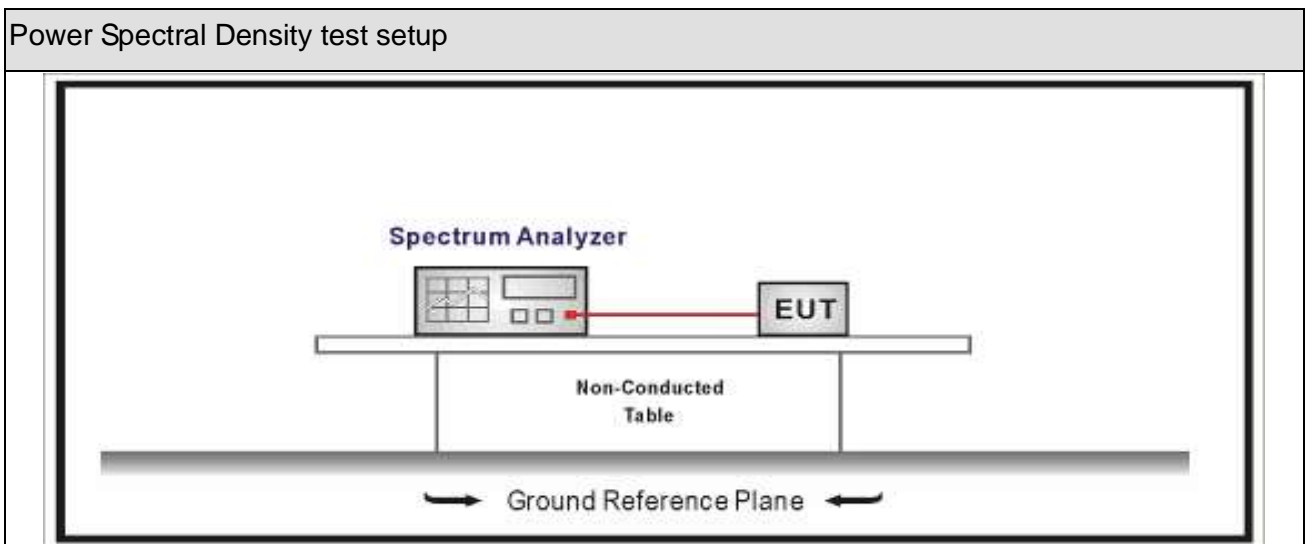

9.3. Limit

Power Spectral Density Limit





Power Spectral Density $\leq 8\text{dBm}/3\text{kHz}$

9.4. Test Procedure

Power Spectral Density Test Method			
	References Rule	Chapter	Description
<input checked="" type="checkbox"/>	ANSI C63.10	11.10	Maximum power spectral density level in the fundamental emission
<input checked="" type="checkbox"/>	ANSI C63.10	11.10.2	Method PKPSD (peak PSD)
<input type="checkbox"/>	ANSI C63.10	11.10.3	Method AVGPSD-1(Duty cycle \geq 98%)
<input type="checkbox"/>	ANSI C63.10	11.10.4	Method AVGPSD-1A(Duty cycle \geq 98%)
<input type="checkbox"/>	ANSI C63.10	11.10.5	Method AVGPSD-2(Duty cycle <98%)
<input type="checkbox"/>	ANSI C63.10	11.10.6	Method AVGPSD-2A(Duty cycle <98%)
<input type="checkbox"/>	ANSI C63.10	11.10.7	Method AVGPSD-3
<input type="checkbox"/>	ANSI C63.10	11.10.8	Method AVGPSD-3A

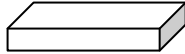
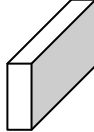
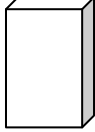
Directional Gain Calculations for In-Band test method				
	Referred Rule		Chapter	Description
<input type="checkbox"/>	KDB 662911		F2)a)	Basic methodology
	<input type="checkbox"/>	KDB 662911	F2)a) (i)	transmit signals are correlated
	<input type="checkbox"/>	KDB 662911	F2)a) (ii)	transmit signals are uncorrelated
<input type="checkbox"/>	KDB 662911		F2)b)	Sectorized antenna systems.
<input type="checkbox"/>	KDB 662911		F2)c)	Cross-polarized antennas
	<input type="checkbox"/>	ANSI C63.10	F2)c) (i)	Cross-polarized antennas
	<input type="checkbox"/>	ANSI C63.10	F2)c) (ii)	Multiple antennas
<input checked="" type="checkbox"/>	KDB 662911		F2)e)	Spatial Multiplexing
	<input type="checkbox"/>	KDB 662911	F2)e) (i)	Antennas have the same gain
	<input type="checkbox"/>	KDB 662911	F2)e) (ii)	Antenna have the different gain with one spatial stream
	<input checked="" type="checkbox"/>	KDB 662911	F2)e) (iii)	Antenna have the different gain with more than one spatial stream
<input checked="" type="checkbox"/>	KDB 662911		F2)f)	Cyclic Delay Diversity (CDD)
	<input type="checkbox"/>	KDB 662911	F2)f) (i)	Antennas have the same gain
	<input type="checkbox"/>	KDB 662911	F2)f) (ii)	Antenna have the different gain with one spatial stream
	<input checked="" type="checkbox"/>	KDB 662911	F2)f) (iii)	Antenna have the different gain with more than one spatial stream

9.5. EUT test definition

Item	Power Spectral Density Test Method			
Device Category	<input type="checkbox"/>	Fixed point-to-point		
	<input type="checkbox"/>	Emit multiple directional beams, simultaneously or sequentially		
	<input checked="" type="checkbox"/>	Other cases		
Test mode	Mode 1~4			
Test method	<input type="checkbox"/>	Radiated		
		X Axis	Y Axis	Z Axis
				
		Worst Axis <input type="checkbox"/>	Worst Axis <input type="checkbox"/>	Worst Axis <input type="checkbox"/>
	<input checked="" type="checkbox"/>	Conducted		
	<input checked="" type="checkbox"/>	Chain 1		
				
	<input checked="" type="checkbox"/>	Chain 1	Chain 2	
				
	<input type="checkbox"/>	Chain 1	Chain 2	Chain 3
				

9.6. Test Result

Product Name	: Wireless Access Point	Power	: AC 120V/60Hz
Test Mode	: Mode 1~4	Test Site	: TR8
Test Date	: 2019.11.06	Test Engineer	: Eric

Radio 1:

Mode	Channel	Test Frequency (MHz)	Measurement PSD (dBm/3kHz)	Limit (dBm/3kHz)	Result
			Worst Chain		
1	01	2412	-1.149	8.0	Pass
1	06	2437	-2.557	8.0	Pass
1	11	2462	-3.470	8.0	Pass
2	01	2412	-5.856	8.0	Pass
2	06	2437	-5.970	8.0	Pass
2	11	2462	-6.452	8.0	Pass
3	01	2412	-6.458	8.0	Pass
3	06	2437	-5.382	8.0	Pass
3	11	2462	-5.789	8.0	Pass
4	01	2412	-5.925	8.0	Pass
4	06	2437	-6.168	8.0	Pass
4	11	2462	-6.589	8.0	Pass

Note1: Both of two chains are tested and only the worst chain of the PSD was showed.

Radio 2(CDD):

Mode	Channel	Test Frequency (MHz)	Measurement PSD (dBm/3kHz)	Limit (dBm/3kHz)	Result
			Worst Chain		
1	01	2412	-1.337	4.24	Pass
1	06	2437	-3.109	4.24	Pass
1	11	2462	-2.936	4.24	Pass
2	01	2412	-6.537	4.24	Pass
2	06	2437	-6.433	4.24	Pass
2	11	2462	-6.284	4.24	Pass
3	01	2412	-6.325	4.24	Pass
3	06	2437	-5.882	4.24	Pass
3	11	2462	-6.397	4.24	Pass
4	01	2412	-7.048	4.24	Pass
4	06	2437	-5.412	4.24	Pass
4	11	2462	-5.315	4.24	Pass

Note1: Both of two chains are tested and only the worst chain of the PSD was showed.

2: PSD limit = 8dBm/3kHz – 10Log(2) – (3.74 + 10Log(2) - 6)

Radio 2(Beamforming):

Mode	Channel	Test Frequency (MHz)	Measurement PSD (dBm/3kHz)	Limit (dBm/3kHz)	Result
			Worst Chain		
3	01	2412	-6.572	4.24	Pass
3	06	2437	-5.713	4.24	Pass
3	11	2462	-6.486	4.24	Pass
4	01	2412	-6.497	4.24	Pass
4	06	2437	-6.903	4.24	Pass
4	11	2462	-5.784	4.24	Pass

Note1: Both of two chains are tested and only the worst chain of the PSD was showed.

2: PSD limit = 8dBm/3kHz – 10Log(2) – (3.74 + 10Log(2) - 6)

10. Antenna Requirement

10.1. Limit

Antenna Requirement Limit	
<p>An intentional radiator shall be designed to ensure that no antenna other than that furnished by the responsible party shall be used with the device. The use of a permanently attached antenna or of an antenna that uses a unique coupling to the intentional radiator shall be considered sufficient to comply with the provisions of this section. The manufacturer may design the unit so that a broken antenna can be replaced by the user, but the use of a standard antenna jack or electrical connector is prohibited. This requirement does not apply to carrier current devices or to devices operated under the provisions of §15.211, §15.213, §15.217, §15.219, or §15.221. Further, this requirement does not apply to intentional radiators that must be professionally installed, such as perimeter protection systems and some field disturbance sensors, or to other intentional radiators which, in accordance with §15.31(d), must be measured at the installation site. However, the installer shall be responsible for ensuring that the proper antenna is employed so that the limits in this part are not exceeded.</p>	

10.2. Antenna Connector Construction

Antenna Connector Construction	
<input type="checkbox"/>	The use of a permanently attached antenna
<input type="checkbox"/>	The antenna use of a unique coupling to the intentional radiator
<input checked="" type="checkbox"/>	The use of a nonstandard antenna jack or electrical connector
Please refer to the attached document "Internal Photograph" to show the antenna connector.	

_____ The End _____