



A D T

FCC TEST REPORT (CO-LOCATED)

REPORT NO.: RF120720C10G-2
MODEL NO.: WS-AP3715e
FCC ID: QXO-AP3715E1
RECEIVED: May 03, 2013
TESTED: Jun. 28 ~ Jun. 29, 2013
ISSUED: Jul. 01, 2013

APPLICANT: Enterasys Networks, Inc.

ADDRESS: 9 Northeastern Blvd. Salem, NH 03079

ISSUED BY: Bureau Veritas Consumer Products Services
(H.K.) Ltd., Taoyuan Branch

LAB ADDRESS: No. 47, 14th Ling, Chia Pau Vil., Lin Kou Dist.,
New Taipei City, Taiwan, R.O.C.

TEST LOCATION: No. 19, Hwa Ya 2nd Rd, Wen Hwa Tsuen, Kwei
Shan Hsiang, Taoyuan Hsien 333, Taiwan, R.O.C.

This report should not be used by the client to claim product certification, approval, or endorsement by TAF or any government agencies.



This report is for your exclusive use. Any copying or replication of this report to or for any other person or entity, or use of our name or trademark, is permitted only with our prior written permission. This report sets forth our findings solely with respect to the test samples identified herein. The results set forth in this report are not indicative or representative of the quality or characteristics of the lot from which a test sample was taken or any similar or identical product unless specifically and expressly noted. Our report includes all of the tests requested by you and the results thereof based upon the information that you provided to us. You have 60 days from date of issuance of this report to notify us of any material error or omission caused by our negligence, provided, however, that such notice shall be in writing and shall specifically address the issue you wish to raise. A failure to raise such issue within the prescribed time shall constitute your unqualified acceptance of the completeness of this report, the tests conducted and the correctness of the report contents. Unless specific mention, the uncertainty of measurement has been explicitly taken into account to declare the compliance or non-compliance to the specification.



A D T

TABLE OF CONTENTS

RELEASE CONTROL RECORD.....	3
1. CERTIFICATION.....	4
2. SUMMARY OF TEST RESULTS.....	5
2.1 MEASUREMENT UNCERTAINTY.....	5
3. GENERAL INFORMATION.....	6
3.1 GENERAL DESCRIPTION OF EUT.....	6
3.2 DESCRIPTION OF TEST MODES.....	8
3.2.1 TEST MODE APPLICABILITY AND TESTED CHANNEL DETAIL.....	9
3.3 DESCRIPTION OF SUPPORT UNITS.....	12
3.3.1 CONFIGURATION OF SYSTEM UNDER TEST.....	12
3.4 GENERAL DESCRIPTION OF APPLIED STANDARDS.....	13
4. TEST TYPES AND RESULTS.....	14
4.1 RADIATED EMISSION AND BANDEDGE MEASUREMENT.....	14
4.1.1 LIMITS OF RADIATED EMISSION AND BANDEDGE MEASUREMENT.....	14
4.1.2 LIMITS OF UNWANTED EMISSION OUT OF THE RESTRICTED BANDS.....	14
4.1.3 TEST INSTRUMENTS.....	15
4.1.4 TEST PROCEDURES.....	16
4.1.5 DEVIATION FROM TEST STANDARD.....	16
4.1.6 TEST SETUP.....	17
4.1.7 EUT OPERATING CONDITIONS.....	17
4.1.8 TEST RESULTS.....	18
4.2 CONDUCTED EMISSION MEASUREMENT.....	48
4.2.1 LIMITS OF CONDUCTED EMISSION MEASUREMENT.....	48
4.2.2 TEST INSTRUMENTS.....	48
4.2.3 TEST PROCEDURES.....	49
4.2.4 DEVIATION FROM TEST STANDARD.....	49
4.2.5 TEST SETUP.....	50
4.2.6 EUT OPERATING CONDITIONS.....	50
4.2.7 TEST RESULTS.....	51
5. PHOTOGRAPHS OF THE TEST CONFIGURATION.....	71
6. INFORMATION ON THE TESTING LABORATORIES.....	72
7. APPENDIX A - MODIFICATIONS RECORDERS FOR ENGINEERING CHANGES TO THE EUT BY THE LAB.....	73



A D T

RELEASE CONTROL RECORD

ISSUE NO.	REASON FOR CHANGE	DATE ISSUED
RF120720C10G-2	Original release	Jul. 01, 2013



A D T

1. CERTIFICATION

PRODUCT: Wireless 802.11 abgn Router
MODEL NO.: WS-AP3715e
BRAND: Enterasys
APPLICANT: Enterasys Networks, Inc.
TESTED: Jun. 28 ~ Jun. 29, 2013
TEST SAMPLE: ENGINEERING SAMPLE
STANDARDS: **FCC Part 15, Subpart C (Section 15.247)**
FCC Part 15, Subpart E (Section 15.407)
ANSI C63.10-2009

The above equipment (model: WS-AP3715e) has been tested by **Bureau Veritas Consumer Products Services (H.K.) Ltd., Taoyuan Branch**, and found compliance with the requirement of the above standards. The test record, data evaluation & Equipment Under Test (EUT) configurations represented herein are true and accurate accounts of the measurements of the sample's EMC characteristics under the conditions specified in this report.

PREPARED BY : Celine Chou , **DATE** : Jul. 01, 2013
Celine Chou / Specialist

APPROVED BY : Ken Liu , **DATE** : Jul. 01, 2013
Ken Liu / Senior Manager



A D T

2. SUMMARY OF TEST RESULTS

The EUT has been tested according to the following specifications:

APPLIED STANDARD: FCC PART 15, SUBPART C (SECTION 15.247) FCC PART 15, SUBPART E (SECTION 15.407)			
STANDARD SECTION	TEST TYPE AND LIMIT	RESULT	REMARK
15.207 15.407(b)(5)	AC Power Conducted Emission	PASS	Meet the requirement of limit. Minimum passing margin is -8.68dB at 0.52109MHz.
15.247(d) 15.407(b)(1/2/3) (b)(5)	Radiated Emissions	PASS	Meet the requirement of limit. Minimum passing margin is -1.1dB at 2500.00MHz.

2.1 MEASUREMENT UNCERTAINTY

Where relevant, the following measurement uncertainty levels have been estimated for tests performed on the EUT as specified in CISPR 16-4-2:

MEASUREMENT	FREQUENCY	UNCERTAINTY
Conducted emissions	9kHz ~ 30MHz	2.44 dB
Radiated emissions	30MHz ~ 200MHz	2.93 dB
	200MHz ~ 1000MHz	2.95 dB
	1GHz ~ 18GHz	2.26 dB
	18GHz ~ 40GHz	1.94 dB

This uncertainty represents an expanded uncertainty expressed at approximately the 95% confidence level using a coverage factor of $k = 2$.



3. GENERAL INFORMATION

3.1 GENERAL DESCRIPTION OF EUT

EUT	Wireless 802.11 abgn Router
MODEL NO.	WS-AP3715e
POWER SUPPLY	5Vdc (host equipment)
MODULATION TYPE	CCK, DQPSK, DBPSK for DSSS 64QAM, 16QAM, QPSK, BPSK for OFDM
MODULATION TECHNOLOGY	DSSS, OFDM
TRANSFER RATE	802.11b: 11.0/ 5.5/ 2.0/ 1.0Mbps 802.11g: 54.0/ 48.0/ 36.0/ 24.0/ 18.0/ 12.0/ 9.0/ 6.0Mbps 802.11a: 54.0/ 48.0/ 36.0/ 24.0/ 18.0/ 12.0/ 9.0/ 6.0Mbps 802.11n: up to 450.0Mbps
OPERATING FREQUENCY	2.4GHz: 2412 ~ 2462MHz 5.0GHz: 5180 ~ 5240MHz, 5745 ~ 5825MHz
NUMBER OF CHANNEL	2.4GHz: 11 for 802.11b, 802.11g, 802.11n (20MHz) 7 for 802.11n (40MHz) 5.0GHz: 5180 ~ 5240MHz: 4 for 802.11a, 802.11n (20MHz) 2 for 802.11n (40MHz) 5745 ~ 5825MHz: 5 for 802.11a, 802.11n (20MHz) 2 for 802.11n (40MHz)
OUTPUT POWER	Antenna 1 626.713mW for 2412 ~ 2462MHz 16.368mW for 5180 ~ 5240MHz 439.751mW for 5745 ~ 5825MHz Antenna 2 697.462mW for 2412 ~ 2462MHz 37.837mW for 5180 ~ 5240MHz 450.177mW for 5745 ~ 5825MHz Antenna 3 349.228mW for 2412 ~ 2462MHz 33.325mW for 5180 ~ 5240MHz 441.213mW for 5745 ~ 5825MHz Antenna 4 691.265mW for 2412 ~ 2462MHz 48.007mW for 5180 ~ 5240MHz 442.201mW for 5745 ~ 5825MHz



A D T

OUTPUT POWER	Antenna 5 691.554mW for 2412 ~ 2462MHz 46.001mW for 5180 ~ 5240MHz 442.201mW for 5745 ~ 5825MHz
ANTENNA TYPE	Refer to Note as below
ANTENNA CONNECTOR	Refer to Note as below
DATA CABLE	N/A
I/O PORTS	N/A
ACCESSORY DEVICES	N/A

NOTE:

1. The EUT incorporates a MIMO function. Physically, the EUT provides three completed transmitters and three receivers.

MODULATION MODE	TX FUNCTION
802.11b	3TX
802.11g	3TX
802.11a	3TX
802.11n (20MHz)	3TX
802.11n (40MHz)	3TX

2. The following antenna type is provided to the EUT.

NO.	ANTENNA TYPE	ANTENNA CONNECTOR	ANTENNA GAIN (dBi)	
			2.4GHz BAND	5GHz BAND
1	Dipole	RSMA	3.0	3.0
2	Panel	RSMA	6.5	5.5
3	MIMO Applications Panel	N-Type	10.0	6.0
4	MIMO Applications OMNI	N-Type	2.0	2.0
5	MIMO Applications Sector	N-Type	5.0	5.0

*Antenna connectors are RSMA and N-Type. (The device is professionally installed)

*Antenna 2 gain is including 6dBi attenuator.

3. The above EUT information is declared by manufacturer and for more detailed features description, please refer to the manufacturer's specifications or user's manual.



3.2 DESCRIPTION OF TEST MODES

FOR 2.4GHz

11 channels are provided for 802.11b, 802.11g and 802.11n (20MHz):

CHANNEL	FREQUENCY	CHANNEL	FREQUENCY
1	2412MHz	7	2442MHz
2	2417MHz	8	2447MHz
3	2422MHz	9	2452MHz
4	2427MHz	10	2457MHz
5	2432MHz	11	2462MHz
6	2437MHz		

7 channels are provided for 802.11n (40MHz):

CHANNEL	FREQUENCY	CHANNEL	FREQUENCY
3	2422MHz	7	2442MHz
4	2427MHz	8	2447MHz
5	2432MHz	9	2452MHz
6	2437MHz		

FOR 5180 ~ 5240MHz

4 channels are provided for 802.11a, 802.11n (20MHz):

CHANNEL	FREQUENCY	CHANNEL	FREQUENCY
36	5180 MHz	44	5220 MHz
40	5200 MHz	48	5240 MHz

2 channels are provided for 802.11n (40MHz):

CHANNEL	FREQUENCY	CHANNEL	FREQUENCY
38	5190 MHz	46	5230 MHz

FOR 5745 ~ 5825MHz

5 channels are provided for 802.11a, 802.11n (20MHz):

CHANNEL	FREQUENCY	CHANNEL	FREQUENCY
149	5745MHz	161	5805MHz
153	5765MHz	165	5825MHz
157	5785MHz		

2 channels are provided for 802.11n (40MHz):

CHANNEL	FREQUENCY	CHANNEL	FREQUENCY
151	5755MHz	159	5795MHz



3.2.1 TEST MODE APPLICABILITY AND TESTED CHANNEL DETAIL

EUT CONFIGURE MODE	APPLICABLE TO			DESCRIPTION
	RE≥1G	RE<1G	PLC	
A	√	√	√	EUT with antenna 1
B	√	√	√	EUT with antenna 2
C	√	√	√	EUT with antenna 3
D	√	√	√	EUT with antenna 4
E	√	√	√	EUT with antenna 5

Where **RE≥1G**: Radiated Emission above 1GHz **RE<1G**: Radiated Emission below 1GHz
PLC: Power Line Conducted Emission

NOTE: The antenna had been pre-tested on the positioned of each 3 axis.

Mode A, B, C, E: The worst case was found when positioned on **Z-plane**.

Mode D: The worst case was found when positioned on **X-plane**.

RADIATED EMISSION TEST (ABOVE 1GHz):

- Pre-Scan has been conducted to determine the worst-case mode from all possible combinations between available modulations, data rates and antenna ports (if EUT with antenna diversity architecture).
- Following channel(s) was (were) selected for the final test as listed below.

EUT CONFIGURE MODE	MODE	FREQ. RANGE (MHz)	AVAILABLE CHANNEL	TESTED CHANNEL	MODULATION TECHNOLOGY	MODULATION TYPE	DATA RATE (Mbps)
A	802.11n (20MHz)	2412~2462	1 to 11	6 + 46	OFDM	DBPSK	7.2
	802.11n (40MHz)	5180~5240	36 to 48		OFDM	DBPSK	15.0
	802.11n (20MHz)	2412~2462	1 to 11	6 + 149	OFDM	DBPSK	7.2
	802.11n (20MHz)	5745~5825	149 to 165		OFDM	DBPSK	7.2
B	802.11b	2412~2462	1 to 11	06 + 40	DSSS	DBPSK	1.0
	802.11a	5180~5240	36 to 48		OFDM	DBPSK	6.0
	802.11b	2412~2462	1 to 11	06 + 157	DSSS	DBPSK	1.0
	802.11a	5745~5825	149 to 165		OFDM	DBPSK	6.0
C	802.11b	2412~2462	1 to 11	11 + 36	DSSS	DBPSK	1.0
	802.11a	5180~5240	36 to 48		OFDM	DBPSK	6.0
	802.11b	2412~2462	1 to 11	11 + 157	DSSS	DBPSK	1.0
	802.11n (20MHz)	5745~5825	149 to 165		OFDM	DBPSK	7.2
D	802.11g	2412~2462	1 to 11	06 + 48	OFDM	BPSK	6.0
	802.11n (20MHz)	5180~5240	36 to 48		OFDM	BPSK	7.2
	802.11g	2412~2462	1 to 11	06 + 165	OFDM	BPSK	6.0
	802.11a	5745~5825	149 to 165		OFDM	BPSK	6.0
E	802.11g	2412~2462	1 to 11	06 + 40	OFDM	BPSK	6.0
	802.11n (20MHz)	5180~5240	36 to 48		OFDM	BPSK	7.2
	802.11g	2412~2462	1 to 11	06 + 157	OFDM	BPSK	6.0
	802.11a	5745~5825	149 to 165		OFDM	BPSK	6.0



RADIATED EMISSION TEST (BELOW 1GHz):

- Pre-Scan has been conducted to determine the worst-case mode from all possible combinations between available modulations, data rates and antenna ports (if EUT with antenna diversity architecture).
- Following channel(s) was (were) selected for the final test as listed below.

EUT CONFIGURE MODE	MODE	FREQ. RANGE (MHz)	AVAILABLE CHANNEL	TESTED CHANNEL	MODULATION TECHNOLOGY	MODULATION TYPE	DATA RATE (Mbps)
A	802.11n (20MHz)	2412~2462	1 to 11	6 + 46	OFDM	DBPSK	7.2
	802.11n (40MHz)	5180~5240	36 to 48		OFDM	DBPSK	15.0
	802.11n (20MHz)	2412~2462	1 to 11	6 + 149	OFDM	DBPSK	7.2
	802.11n (20MHz)	5745~5825	149 to 165		OFDM	DBPSK	7.2
B	802.11b	2412~2462	1 to 11	06 + 40	DSSS	DBPSK	1.0
	802.11a	5180~5240	36 to 48		OFDM	DBPSK	6.0
	802.11b	2412~2462	1 to 11	06 + 157	DSSS	DBPSK	1.0
	802.11a	5745~5825	149 to 165		OFDM	DBPSK	6.0
C	802.11b	2412~2462	1 to 11	11 + 36	DSSS	DBPSK	1.0
	802.11a	5180~5240	36 to 48		OFDM	DBPSK	6.0
	802.11b	2412~2462	1 to 11	11 + 157	DSSS	DBPSK	1.0
	802.11n (20MHz)	5745~5825	149 to 165		OFDM	DBPSK	7.2
D	802.11g	2412~2462	1 to 11	06 + 48	OFDM	BPSK	6.0
	802.11n (20MHz)	5180~5240	36 to 48		OFDM	BPSK	7.2
	802.11g	2412~2462	1 to 11	06 + 165	OFDM	BPSK	6.0
	802.11a	5745~5825	149 to 165		OFDM	BPSK	6.0
E	802.11g	2412~2462	1 to 11	06 + 40	OFDM	BPSK	6.0
	802.11n (20MHz)	5180~5240	36 to 48		OFDM	BPSK	7.2
	802.11g	2412~2462	1 to 11	06 + 157	OFDM	BPSK	6.0
	802.11a	5745~5825	149 to 165		OFDM	BPSK	6.0



A D T

CONDUCTED EMISSION TEST:

- Pre-Scan has been conducted to determine the worst-case mode from all possible combinations between available modulations, data rates and antenna ports (if EUT with antenna diversity architecture).
- Following channel(s) was (were) selected for the final test as listed below.

EUT CONFIGURE MODE	MODE	FREQ. RANGE (MHz)	AVAILABLE CHANNEL	TESTED CHANNEL	MODULATION TECHNOLOGY	MODULATION TYPE	DATA RATE (Mbps)
A	802.11n (20MHz)	2412~2462	1 to 11	6 + 46	OFDM	DBPSK	7.2
	802.11n (40MHz)	5180~5240	36 to 48		OFDM	DBPSK	15.0
	802.11n (20MHz)	2412~2462	1 to 11	6 + 149	OFDM	DBPSK	7.2
	802.11n (20MHz)	5745~5825	149 to 165		OFDM	DBPSK	7.2
B	802.11b	2412~2462	1 to 11	06 + 40	DSSS	DBPSK	1.0
	802.11a	5180~5240	36 to 48		OFDM	DBPSK	6.0
	802.11b	2412~2462	1 to 11	06 + 157	DSSS	DBPSK	1.0
	802.11a	5745~5825	149 to 165		OFDM	DBPSK	6.0
C	802.11b	2412~2462	1 to 11	11 + 36	DSSS	DBPSK	1.0
	802.11a	5180~5240	36 to 48		OFDM	DBPSK	6.0
	802.11b	2412~2462	1 to 11	11 + 157	DSSS	DBPSK	1.0
	802.11n (20MHz)	5745~5825	149 to 165		OFDM	DBPSK	7.2
D	802.11g	2412~2462	1 to 11	06 + 48	OFDM	BPSK	6.0
	802.11n (20MHz)	5180~5240	36 to 48		OFDM	BPSK	7.2
	802.11g	2412~2462	1 to 11	06 + 165	OFDM	BPSK	6.0
	802.11a	5745~5825	149 to 165		OFDM	BPSK	6.0
E	802.11g	2412~2462	1 to 11	06 + 40	OFDM	BPSK	6.0
	802.11n (20MHz)	5180~5240	36 to 48		OFDM	BPSK	7.2
	802.11g	2412~2462	1 to 11	06 + 157	OFDM	BPSK	6.0
	802.11a	5745~5825	149 to 165		OFDM	BPSK	6.0

TEST CONDITION:

APPLICABLE TO	ENVIRONMENTAL CONDITIONS	INPUT POWER	TESTED BY
RE≥1G	25deg. C, 65%RH	120Vac, 60Hz	Haru Yang Chris Lin
RE<1G	25deg. C, 65%RH	120Vac, 60Hz	Antony Lee Chris Lin
PLC	24deg. C, 64%RH 26deg. C, 65%RH	120Vac, 60Hz	Match Tsui Chris Lin

3.3 DESCRIPTION OF SUPPORT UNITS

The EUT has been tested as an independent unit together with other necessary accessories or support units. The following support units or accessories were used to form a representative test configuration during the tests.

NO.	PRODUCT	BRAND	MODEL NO.	SERIAL NO.	FCC ID
1	NOTEBOOK	DELL	E5420	33MLMQ1	FCC Doc Approved
2	CONVERTIBLE BOARD	NA	NA	NA	NA

NO.	SIGNAL CABLE DESCRIPTION OF THE ABOVE SUPPORT UNITS
1	NA
2	NA

NOTE:

1. All power cords of the above support units are non shielded (1.8m).
2. Item 2 was provided by client.

3.3.1 CONFIGURATION OF SYSTEM UNDER TEST

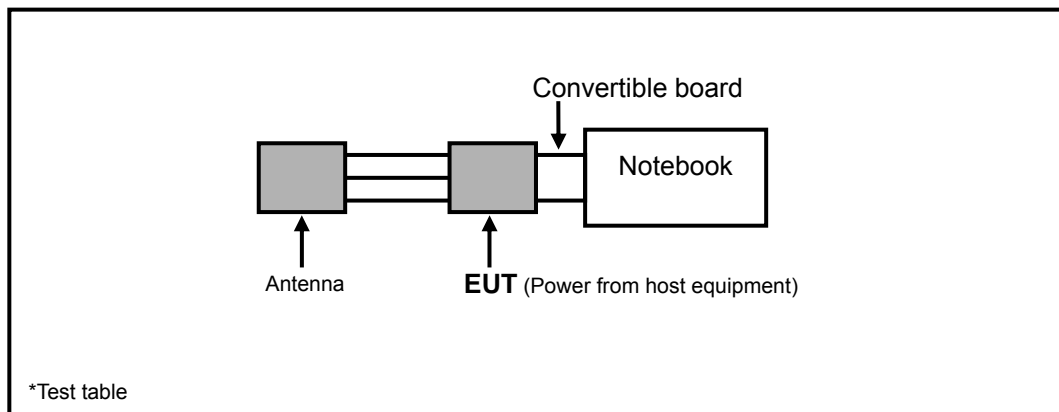



A D T

3.4 GENERAL DESCRIPTION OF APPLIED STANDARDS

The EUT is a RF Product. According to the specifications of the manufacturer, it must comply with the requirements of the following standards:

FCC Part 15, Subpart C (Section 15.247)

FCC Part 15, Subpart E (Section 15.407)

ANSI C63.10-2009

All test items have been performed and recorded as per the above standards.



4. TEST TYPES AND RESULTS

4.1 RADIATED EMISSION AND BANDEDGE MEASUREMENT

4.1.1 LIMITS OF RADIATED EMISSION AND BANDEDGE MEASUREMENT

Emissions radiated outside of the specified bands, shall be according to the general radiated limits in 15.209 as following:

FREQUENCIES (MHz)	FIELD STRENGTH (microvolts/meter)	MEASUREMENT DISTANCE (meters)
0.009 ~ 0.490	2400/F(kHz)	300
0.490 ~ 1.705	24000/F(kHz)	30
1.705 ~ 30.0	30	30
30 ~ 88	100	3
88 ~ 216	150	3
216 ~ 960	200	3
Above 960	500	3

NOTE:

1. The lower limit shall apply at the transition frequencies.
2. Emission level (dBuV/m) = 20 log Emission level (uV/m).
3. For frequencies above 1000MHz, the field strength limits are based on average detector, however, the peak field strength of any emission shall not exceed the maximum permitted average limits, specified above by more than 20dB under any condition of modulation.

4.1.2 LIMITS OF UNWANTED EMISSION OUT OF THE RESTRICTED BANDS

APPLICABLE TO	LIMIT	
√	FIELD STRENGTH AT 3m (dBμV/m)	
	PK	AV
	74	54
	EIRP LIMIT (dBm)	EQUIVALENT FIELD STRENGTH AT 3m (dBμV/m)
	PK	PK
	-27	68.3

NOTE: The following formula is used to convert the equipment isotropic radiated power (eirp) to field strength:

$$E = \frac{1000000\sqrt{30P}}{3} \mu\text{V/m, where P is the eirp (Watts).}$$



A D T

4.1.3 TEST INSTRUMENTS

DESCRIPTION & MANUFACTURER	MODEL NO.	SERIAL NO.	DATE OF CALIBRATION	DUE DATE OF CALIBRATION
Test Receiver ROHDE & SCHWARZ	ESCS30	100289	Nov. 16, 2012	Nov. 15, 2013
Spectrum Analyzer ROHDE & SCHWARZ	FSP40	100269	Jan. 28, 2013	Jan. 27, 2014
BILOG Antenna SCHWARZBECK	VULB9168	9168-156	Mar. 22, 2013	Mar. 21, 2014
HORN Antenna SCHWARZBECK	BBHA 9120 D	9120D-209	Sep. 03, 2012	Sep. 02, 2013
HORN Antenna SCHWARZBECK	BBHA 9170	148	Jul. 11, 2012	Jul. 10, 2013
Preamplifier Agilent	8449B	3008A01911	Oct. 25, 2012	Oct. 24, 2013
Preamplifier Agilent	8447D	2944A10638	Oct. 25, 2012	Oct. 24, 2013
RF signal cable HUBER+SUHNNER	SUCOFLEX 104	295013/4 283403/4	Aug. 28, 2012	Aug. 27, 2013
RF signal cable Worken	8D-FB	Cable-HYCH9-01	Aug. 11, 2012	Aug. 10, 2013
Software BV ADT	ADT_Radiated_ V7.6.15.9.3	NA	NA	NA
Antenna Tower EMCO	2070/2080	512.835.4684	NA	NA
Turn Table EMCO	2087-2.03	NA	NA	NA
Antenna Tower & Turn Table Controller EMCO	2090	NA	NA	NA
26GHz ~ 40GHz Amplifier	EM26400	815221	Oct. 25, 2012	Oct. 24, 2013
Turn Table Controller ADT.	SC100.	SC93021704	NA	NA
High Speed Peak Power Meter	ML2495A	0824012	Aug. 22, 2012	Aug. 21, 2013
Power Sensor	MA2411B	0738171	Jul. 30, 2012	Jul. 29, 2013

- NOTE:**
1. The calibration interval of the above test instruments is 12 months and the calibrations are traceable to NML/ROC and NIST/USA.
 2. The test was performed in HwaYa Chamber 9.
 3. The horn antenna and HP preamplifier (model: 8449B) are used only for the measurement of emission frequency above 1GHz if tested.
 4. The FCC Site Registration No. is 215374.
 5. The IC Site Registration No. is IC 7450F-9.



A D T

4.1.4 TEST PROCEDURES

- a. The EUT was placed on the top of a rotating table 0.8 meters above the ground at a 3 meters semi-anechoic chamber. The table was rotated 360 degrees to determine the position of the highest radiation.
- b. The EUT was set 3 meters away from the interference-receiving antenna, which was mounted on the top of a variable-height antenna tower.
- c. The antenna is a broadband antenna, and its height is varied from one meter to four meters above the ground to determine the maximum value of the field strength. Both horizontal and vertical polarizations of the antenna are set to make the measurement.
- d. For each suspected emission, the EUT was arranged to its worst case and then the antenna was tuned to heights from 1 meter to 4 meters and the rotatable table was turned from 0 degrees to 360 degrees to find the maximum reading.
- e. The test-receiver system was set to Peak Detect Function and Specified Bandwidth with Maximum Hold Mode.
- f. If the emission level of the EUT in peak mode was lower than the limit specified, then testing could be stopped and the peak values of the EUT would be reported. Otherwise the emissions would be re-tested one by one using peak, quasi-peak or average method as specified and then reported in a data sheet.

NOTE:

1. The resolution bandwidth and video bandwidth of test receiver/spectrum analyzer is 120kHz for Quasi-peak detection at frequency below 1GHz.
2. The resolution bandwidth of test receiver/spectrum analyzer is 100kHz and video bandwidth is 300kHz for Peak detection at frequency above 1GHz.
3. The resolution bandwidth of test receiver/spectrum analyzer is 1MHz and the video bandwidth is 1kHz for Average detection (AV) at frequency above 1GHz.
4. All modes of operation were investigated and the worst-case emissions are reported.

4.1.5 DEVIATION FROM TEST STANDARD

No deviation.

4.1.6 TEST SETUP

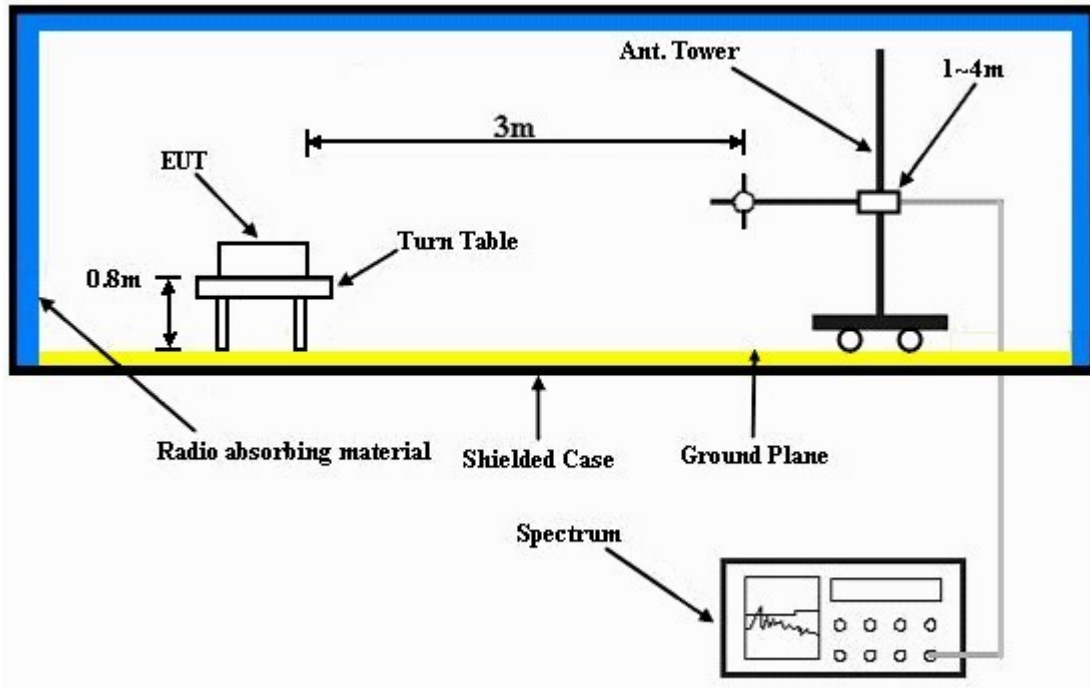

For the actual test configuration, please refer to the attached file (Test Setup Photo).

4.1.7 EUT OPERATING CONDITIONS

- a. Plugged the EUT into notebook via external board and placed them on the testing table.
- b. The notebook system ran a test program (provided by manufacturer) to enable EUT under transmission condition continuously at specific channel frequency.
- c. The necessary accessories enable the system in full functions.



A D T

4.1.8 TEST RESULTS

ABOVE 1GHz DATA :

TEST MODE A

802.11n (20MHz) + 802.11n (40MHz)

EUT TEST CONDITION		MEASUREMENT DETAIL	
CHANNEL	CH 6 +CH 46	FREQUENCY RANGE	1 ~ 25GHz
INPUT POWER (SYSTEM)	120Vac, 60Hz	DETECTOR FUNCTION	Peak (PK) Average (AV)
ENVIRONMENTAL CONDITIONS	25deg. C, 65%RH	TESTED BY	Haru Yang

ANTENNA POLARITY & TEST DISTANCE: HORIZONTAL AT 3 M								
NO.	FREQ. (MHz)	EMISSION LEVEL (dBuV/m)	LIMIT (dBuV/m)	MARGIN (dB)	ANTENNA HEIGHT (m)	TABLE ANGLE (Degree)	RAW VALUE (dBuV)	CORRECTION FACTOR (dB/m)
1	*2437.00	110.4 PK			1.11 H	18	79.00	31.40
2	*2437.00	100.7 AV			1.11 H	18	69.30	31.40
3	2500.00	58.2 PK	74.0	-15.8	1.00 H	26	26.60	31.60
4	2500.00	47.7 AV	54.0	-6.3	1.00 H	26	16.10	31.60
5	4874.00	55.6 PK	74.0	-18.4	1.00 H	199	18.30	37.30
6	4874.00	42.6 AV	54.0	-11.4	1.00 H	199	5.30	37.30
7	5000.00	56.5 PK	74.0	-17.5	1.07 H	258	18.90	37.60
8	5000.00	43.0 AV	54.0	-11.0	1.07 H	258	5.40	37.60
9	5150.00	55.4 PK	74.0	-18.6	1.11 H	77	17.50	37.90
10	5150.00	43.2 AV	54.0	-10.8	1.11 H	77	5.30	37.90
11	*5230.00	88.7 PK			1.11 H	132	50.70	38.00
12	*5230.00	76.7 AV			1.11 H	132	38.70	38.00
13	#10460.00	58.2 PK	74.0	-15.8	1.03 H	225	9.30	48.90
14	#10460.00	47.2 AV	54.0	-6.7	1.03 H	225	-1.7	48.90

- REMARKS:**
1. Emission level (dBuV/m) = Raw Value (dBuV) + Correction Factor (dB/m).
 2. Correction Factor (dB/m) = Antenna Factor (dB/m) + Cable Factor (dB).
 3. The other emission levels were very low against the limit.
 4. Margin value = Emission level – Limit value.
 5. “ * “: Fundamental frequency.
 6. The limit value is defined as per 15.247.
 7. “#”:The radiated frequency is out the restricted band.



A D T

EUT TEST CONDITION		MEASUREMENT DETAIL	
CHANNEL	CH 6 +CH 46	FREQUENCY RANGE	1 ~ 25GHz
INPUT POWER (SYSTEM)	120Vac, 60Hz	DETECTOR FUNCTION	Peak (PK) Average (AV)
ENVIRONMENTAL CONDITIONS	25deg. C, 65%RH	TESTED BY	Haru Yang

ANTENNA POLARITY & TEST DISTANCE: VERTICAL AT 3 M								
NO.	FREQ. (MHz)	EMISSION LEVEL (dBuV/m)	LIMIT (dBuV/m)	MARGIN (dB)	ANTENNA HEIGHT (m)	TABLE ANGLE (Degree)	RAW VALUE (dBuV)	CORRECTION FACTOR (dB/m)
1	*2437.00	117.9 PK			1.16 V	346	86.80	31.10
2	*2437.00	107.5 AV			1.16 V	346	76.40	31.10
3	2500.00	63.0 PK	74.0	-11.0	1.11 V	322	31.60	31.40
4	2500.00	52.9 AV	54.0	-1.1	1.11 V	322	21.50	31.40
5	4874.00	56.2 PK	74.0	-17.8	1.04 V	196	18.90	37.30
6	4874.00	43.1 AV	54.0	-10.9	1.04 V	196	5.80	37.30
7	5000.00	56.8 PK	74.0	-17.2	1.00 V	294	19.20	37.60
8	5000.00	44.4 AV	54.0	-9.6	1.00 V	294	6.80	37.60
9	5150.00	56.5 PK	74.0	-17.5	1.01 V	56	18.60	37.90
10	5150.00	43.3 AV	54.0	-10.7	1.01 V	56	5.40	37.90
11	*5230.00	98.9 PK			1.01 V	56	60.90	38.00
12	*5230.00	86.2 AV			1.01 V	56	48.20	38.00
13	#10460.00	62.9 PK	74.0	-11.1	1.03 V	224	8.40	49.60
14	#10460.00	49.5 AV	54.0	-4.5	1.03 V	224	8.40	49.60

- REMARKS:**
1. Emission level (dBuV/m) = Raw Value (dBuV) + Correction Factor (dB/m).
 2. Correction Factor (dB/m) = Antenna Factor (dB/m) + Cable Factor (dB).
 3. The other emission levels were very low against the limit.
 4. Margin value = Emission level – Limit value.
 5. “ * “: Fundamental frequency.
 6. The limit value is defined as per 15.247.
 7. “#”:The radiated frequency is out the restricted band.



A D T

802.11n (20MHz) + 802.11n (20MHz)

EUT TEST CONDITION		MEASUREMENT DETAIL	
CHANNEL	CH 6 +CH 149	FREQUENCY RANGE	1 ~ 25GHz
INPUT POWER (SYSTEM)	120Vac, 60Hz	DETECTOR FUNCTION	Peak (PK) Average (AV)
ENVIRONMENTAL CONDITIONS	25deg. C, 65%RH	TESTED BY	Haru Yang

ANTENNA POLARITY & TEST DISTANCE: HORIZONTAL AT 3 M								
NO.	FREQ. (MHz)	EMISSION LEVEL (dBuV/m)	LIMIT (dBuV/m)	MARGIN (dB)	ANTENNA HEIGHT (m)	TABLE ANGLE (Degree)	RAW VALUE (dBuV)	CORRECTION FACTOR (dB/m)
1	*2437.00	110.8 PK			1.08 H	18	79.40	31.40
2	*2437.00	100.6 AV			1.08 H	18	69.20	31.40
3	2500.00	58.6 PK	74.0	-15.4	1.00 H	27	27.00	31.60
4	2500.00	48.0 AV	54.0	-6.0	1.00 H	27	16.40	31.60
5	4874.00	55.8 PK	74.0	-18.2	1.00 H	73	18.50	37.30
6	4874.00	43.1 AV	54.0	-10.9	1.00 H	73	5.80	37.30
7	5000.00	55.2 PK	74.0	-18.8	1.11 H	134	17.60	37.60
8	5000.00	43.3 AV	54.0	-10.7	1.11 H	134	5.70	37.60
9	#5725.00	69.0 PK	79.2	-10.2	1.00 H	53	30.00	39.00
10	#5725.00	59.7 AV	69.9	-10.2	1.00 H	53	20.70	39.00
11	*5745.00	99.2 PK			1.00 H	8	60.20	39.00
12	*5745.00	89.9 AV			1.00 H	8	50.90	39.00
13	11490.00	59.4 PK	74.0	-14.6	1.00 H	138	9.10	50.30
14	11490.00	46.0 AV	54.0	-8.0	1.00 H	138	-4.30	50.30

- REMARKS:**
1. Emission level (dBuV/m) = Raw Value (dBuV) + Correction Factor (dB/m).
 2. Correction Factor (dB/m) = Antenna Factor (dB/m) + Cable Factor (dB).
 3. The other emission levels were very low against the limit.
 4. Margin value = Emission level – Limit value.
 5. “ * “: Fundamental frequency.
 6. The limit value is defined as per 15.247.
 7. “#”:The radiated frequency is out the restricted band.



A D T

EUT TEST CONDITION		MEASUREMENT DETAIL	
CHANNEL	CH 6 +CH 149	FREQUENCY RANGE	1 ~ 25GHz
INPUT POWER (SYSTEM)	120Vac, 60Hz	DETECTOR FUNCTION	Peak (PK) Average (AV)
ENVIRONMENTAL CONDITIONS	25deg. C, 65%RH	TESTED BY	Haru Yang

ANTENNA POLARITY & TEST DISTANCE: VERTICAL AT 3 M								
NO.	FREQ. (MHz)	EMISSION LEVEL (dBuV/m)	LIMIT (dBuV/m)	MARGIN (dB)	ANTENNA HEIGHT (m)	TABLE ANGLE (Degree)	RAW VALUE (dBuV)	CORRECTION FACTOR (dB/m)
1	*2437.00	117.7 PK			1.12 V	345	86.30	31.40
2	*2437.00	107.8 AV			1.12 V	345	76.40	31.40
3	2500.00	67.0 PK	74.0	-7.0	1.07 V	78	35.40	31.60
4	2500.00	51.9 AV	54.0	-2.1	1.07 V	78	20.30	31.60
5	4874.00	57.2 PK	74.0	-16.8	1.05 V	182	19.90	37.30
6	4874.00	43.8 AV	54.0	-10.2	1.05 V	182	6.50	37.30
7	5000.00	58.8 PK	74.0	-15.2	1.00 V	344	21.20	37.60
8	5000.00	49.5 AV	54.0	-4.5	1.00 V	344	11.90	37.60
9	#5725.00	78.9 PK	93.0	-14.1	1.00 V	358	39.90	39.00
10	#5725.00	68.5 AV	82.6	-14.1	1.00 V	358	29.50	39.00
11	*5745.00	113.0 PK			1.00 V	344	74.00	39.00
12	*5745.00	102.6 AV			1.00 V	344	63.60	39.00
13	11490.00	59.5 PK	74.0	-14.5	1.00 V	145	9.20	50.30
14	11490.00	46.6 AV	54.0	-7.4	1.00 V	145	-3.70	50.30

- REMARKS:**
1. Emission level (dBuV/m) = Raw Value (dBuV) + Correction Factor (dB/m).
 2. Correction Factor (dB/m) = Antenna Factor (dB/m) + Cable Factor (dB).
 3. The other emission levels were very low against the limit.
 4. Margin value = Emission level – Limit value.
 5. “ * “: Fundamental frequency.
 6. The limit value is defined as per 15.247.
 7. "#":The radiated frequency is out the restricted band.



A D T

TEST MODE B

802.11b + 802.11a

EUT TEST CONDITION		MEASUREMENT DETAIL	
CHANNEL	CH 6 + CH 40	FREQUENCY RANGE	1 ~ 25GHz
INPUT POWER	120Vac, 60Hz	DETECTOR FUNCTION	Peak (PK) Average (AV)
ENVIRONMENTAL CONDITIONS	25deg. C, 65%RH	TESTED BY	Chris Lin

ANTENNA POLARITY & TEST DISTANCE: HORIZONTAL AT 3 M								
NO.	FREQ. (MHz)	EMISSION LEVEL (dBuV/m)	LIMIT (dBuV/m)	MARGIN (dB)	ANTENNA HEIGHT (m)	TABLE ANGLE (Degree)	RAW VALUE (dBuV)	CORRECTION FACTOR (dB/m)
1	*2437.00	97.5 PK			1.20 H	206	61.70	35.80
2	*2437.00	94.0 AV			1.20 H	206	58.20	35.80
3	4874.00	52.5 PK	74.0	-21.5	1.03 H	55	9.30	43.20
4	4874.00	47.0 AV	54.0	-7.0	1.03 H	55	3.80	43.20
5	*5200.00	104.3 PK			1.23 H	20	60.40	43.90
6	*5200.00	94.2 AV			1.23 H	20	50.30	43.90
7	7311.00	54.2 PK	74.0	-19.8	1.20 H	302	6.50	47.70
8	7311.00	44.3 AV	54.0	-9.7	1.20 H	302	-3.40	47.70
9	#10400.00	55.5 PK	74.0	-18.5	1.03 H	97	4.60	50.90
10	#10400.00	43.5 AV	54.0	-10.5	1.03 H	97	-7.40	50.90
11	15600.00	60.5 PK	74.0	-13.5	1.13 H	208	6.50	54.00
12	15600.00	50.5 AV	54.0	-3.5	1.13 H	208	-3.50	54.00

REMARKS:

1. Emission level (dBuV/m) = Raw Value (dBuV) + Correction Factor (dB/m).
2. Correction Factor (dB/m) = Antenna Factor (dB/m) + Cable Factor (dB).
3. The other emission levels were very low against the limit.
4. Margin value = Emission level – Limit value.
5. “ * “: Fundamental frequency.
6. “#”:The radiated frequency is out the restricted band.



A D T

EUT TEST CONDITION		MEASUREMENT DETAIL	
CHANNEL	CH 6 + CH 40	FREQUENCY RANGE	1 ~ 25GHz
INPUT POWER	120Vac, 60Hz	DETECTOR FUNCTION	Peak (PK) Average (AV)
ENVIRONMENTAL CONDITIONS	25deg. C, 65%RH	TESTED BY	Chris Lin

ANTENNA POLARITY & TEST DISTANCE: VERTICAL AT 3 M								
NO.	FREQ. (MHz)	EMISSION LEVEL (dBuV/m)	LIMIT (dBuV/m)	MARGIN (dB)	ANTENNA HEIGHT (m)	TABLE ANGLE (Degree)	RAW VALUE (dBuV)	CORRECTION FACTOR (dB/m)
1	*2437.00	116.5 PK			1.34 V	13	80.70	35.80
2	*2437.00	113.2 AV			1.34 V	13	77.40	35.80
3	2483.50	64.0 PK	74.0	-10.0	1.11 V	16	28.10	35.90
4	2483.50	52.5 AV	54.0	-1.5	1.11 V	16	16.60	35.90
5	4874.00	53.8 PK	74.0	-20.2	1.23 V	307	10.60	43.20
6	4874.00	50.2 AV	54.0	-3.8	1.23 V	307	7.00	43.20
7	*5200.00	106.9 PK			1.03 V	55	63.00	43.90
8	*5200.00	96.4 AV			1.03 V	55	52.50	43.90
9	7311.00	56.5 PK	74.0	-17.5	1.03 V	112	8.80	47.70
10	7311.00	49.8 AV	54.0	-4.2	1.03 V	112	2.10	47.70
11	#10400.00	57.5 PK	74.0	-16.5	1.23 V	309	6.60	50.90
12	#10400.00	45.0 AV	54.0	-9.0	1.23 V	309	-5.90	50.90
13	15600.00	62.8 PK	74.0	-11.2	1.23 V	147	8.80	54.00
14	15600.00	50.2 AV	54.0	-3.8	1.23 V	147	-3.80	54.00

REMARKS:

1. Emission level (dBuV/m) = Raw Value (dBuV) + Correction Factor (dB/m).
2. Correction Factor (dB/m) = Antenna Factor (dB/m) + Cable Factor (dB).
3. The other emission levels were very low against the limit.
4. Margin value = Emission level – Limit value.
5. “ * “: Fundamental frequency.
6. "#":The radiated frequency is out the restricted band.



A D T

802.11b + 802.11a

EUT TEST CONDITION		MEASUREMENT DETAIL	
CHANNEL	CH 6 + CH 157	FREQUENCY RANGE	1 ~ 25GHz
INPUT POWER	120Vac, 60Hz	DETECTOR FUNCTION	Peak (PK) Average (AV)
ENVIRONMENTAL CONDITIONS	25deg. C, 65%RH	TESTED BY	Chris Lin

ANTENNA POLARITY & TEST DISTANCE: HORIZONTAL AT 3 M								
NO.	FREQ. (MHz)	EMISSION LEVEL (dBuV/m)	LIMIT (dBuV/m)	MARGIN (dB)	ANTENNA HEIGHT (m)	TABLE ANGLE (Degree)	RAW VALUE (dBuV)	CORRECTION FACTOR (dB/m)
1	*2437.00	97.2 PK			1.03 H	65	61.40	35.80
2	*2437.00	94.5 AV			1.03 H	65	58.70	35.80
3	4874.00	52.3 PK	74.0	-21.7	1.02 H	223	9.10	43.20
4	4874.00	47.0 AV	54.0	-7.0	1.02 H	223	3.80	43.20
5	*5785.00	111.5 PK			1.10 H	10	66.80	44.70
6	*5785.00	101.3 AV			1.10 H	10	56.60	44.70
7	7311.00	54.1 PK	74.0	-19.9	1.32 H	98	6.40	47.70
8	7311.00	44.0 AV	54.0	-10.0	1.32 H	98	-3.70	47.70
9	11570.00	57.0 PK	74.0	-17.0	1.23 H	52	4.20	52.80
10	11570.00	44.7 AV	54.0	-9.3	1.23 H	52	-8.10	52.80
11	#17355.00	63.0 PK	91.5	-28.5	1.02 H	74	3.00	60.00
12	#17355.00	52.0 AV	81.3	-29.3	1.02 H	74	-8.00	60.00

REMARKS:

1. Emission level (dBuV/m) = Raw Value (dBuV) + Correction Factor (dB/m).
2. Correction Factor (dB/m) = Antenna Factor (dB/m) + Cable Factor (dB).
3. The other emission levels were very low against the limit.
4. Margin value = Emission level – Limit value.
5. “ * “: Fundamental frequency.
6. "#":The radiated frequency is out the restricted band.



A D T

EUT TEST CONDITION		MEASUREMENT DETAIL	
CHANNEL	CH 6 + CH 157	FREQUENCY RANGE	1 ~ 25GHz
INPUT POWER	120Vac, 60Hz	DETECTOR FUNCTION	Peak (PK) Average (AV)
ENVIRONMENTAL CONDITIONS	25deg. C, 65%RH	TESTED BY	Chris Lin

ANTENNA POLARITY & TEST DISTANCE: VERTICAL AT 3 M								
NO.	FREQ. (MHz)	EMISSION LEVEL (dBuV/m)	LIMIT (dBuV/m)	MARGIN (dB)	ANTENNA HEIGHT (m)	TABLE ANGLE (Degree)	RAW VALUE (dBuV)	CORRECTION FACTOR (dB/m)
1	*2437.00	116.2 PK			1.20 V	325	80.40	35.80
2	*2437.00	113.0 AV			1.20 V	325	77.20	35.80
3	2483.50	63.8 PK	74.0	-10.2	1.02 V	74	27.90	35.90
4	2483.50	52.5 AV	54.0	-1.5	1.02 V	74	16.60	35.90
5	4874.00	53.8 PK	74.0	-20.2	1.07 V	41	10.60	43.20
6	4874.00	50.2 AV	54.0	-3.8	1.07 V	41	7.00	43.20
7	*5785.00	111.2 PK			1.10 V	30	66.50	44.70
8	*5785.00	101.1 AV			1.10 V	30	56.40	44.70
9	7311.00	56.5 PK	74.0	-17.5	1.13 V	208	8.80	47.70
10	7311.00	49.8 AV	54.0	-4.2	1.13 V	208	2.10	47.70
11	11570.00	60.0 PK	74.0	-14.0	1.02 V	330	7.20	52.80
12	11570.00	47.1 AV	54.0	-6.9	1.02 V	330	-5.70	52.80
13	#17355.00	65.8 PK	91.2	-25.4	1.32 V	209	5.80	60.00
14	#17355.00	52.7 AV	81.1	-28.4	1.32 V	209	-7.30	60.00

REMARKS:

1. Emission level (dBuV/m) = Raw Value (dBuV) + Correction Factor (dB/m).
2. Correction Factor (dB/m) = Antenna Factor (dB/m) + Cable Factor (dB).
3. The other emission levels were very low against the limit.
4. Margin value = Emission level – Limit value.
5. “ * “: Fundamental frequency.
6. "#":The radiated frequency is out the restricted band.



A D T

TEST MODE C

802.11b + 802.11a

EUT TEST CONDITION		MEASUREMENT DETAIL	
CHANNEL	CH 11 + CH 36	FREQUENCY RANGE	1 ~ 25GHz
INPUT POWER	120Vac, 60Hz	DETECTOR FUNCTION	Peak (PK) Average (AV)
ENVIRONMENTAL CONDITIONS	25deg. C, 65%RH	TESTED BY	Chris Lin

ANTENNA POLARITY & TEST DISTANCE: HORIZONTAL AT 3 M								
NO.	FREQ. (MHz)	EMISSION LEVEL (dBuV/m)	LIMIT (dBuV/m)	MARGIN (dB)	ANTENNA HEIGHT (m)	TABLE ANGLE (Degree)	RAW VALUE (dBuV)	CORRECTION FACTOR (dB/m)
1	*2462.00	100.5 PK			1.23 H	201	64.60	35.90
2	*2462.00	97.0 AV			1.23 H	201	61.10	35.90
3	2483.50	59.8 PK	74.0	-14.2	1.03 H	201	23.90	35.90
4	2483.50	48.2 AV	54.0	-5.8	1.03 H	201	12.30	35.90
5	4924.00	49.5 PK	74.0	-24.5	1.10 H	203	6.10	43.40
6	4924.00	35.2 AV	54.0	-18.8	1.10 H	203	-8.20	43.40
7	5150.00	58.5 PK	74.0	-15.5	1.02 H	130	14.70	43.80
8	5150.00	46.0 AV	54.0	-8.0	1.02 H	130	2.20	43.80
9	*5180.00	93.8 PK			1.02 H	147	49.90	43.90
10	*5180.00	83.7 AV			1.02 H	147	39.80	43.90
11	#10360.00	55.2 PK	74.0	-18.8	1.30 H	47	4.30	50.90
12	#10360.00	43.1 AV	54.0	-10.9	1.30 H	47	-7.80	50.90

REMARKS:

1. Emission level (dBuV/m) = Raw Value (dBuV) + Correction Factor (dB/m).
2. Correction Factor (dB/m) = Antenna Factor (dB/m) + Cable Factor (dB).
3. The other emission levels were very low against the limit.
4. Margin value = Emission level – Limit value.
5. “ * “: Fundamental frequency.
6. “#”:The radiated frequency is out the restricted band.



A D T

EUT TEST CONDITION		MEASUREMENT DETAIL	
CHANNEL	CH 11 + CH 36	FREQUENCY RANGE	1 ~ 25GHz
INPUT POWER	120Vac, 60Hz	DETECTOR FUNCTION	Peak (PK) Average (AV)
ENVIRONMENTAL CONDITIONS	25deg. C, 65%RH	TESTED BY	Chris Lin

ANTENNA POLARITY & TEST DISTANCE: VERTICAL AT 3 M								
NO.	FREQ. (MHz)	EMISSION LEVEL (dBuV/m)	LIMIT (dBuV/m)	MARGIN (dB)	ANTENNA HEIGHT (m)	TABLE ANGLE (Degree)	RAW VALUE (dBuV)	CORRECTION FACTOR (dB/m)
1	2384.00	62.0 PK	74.0	-12.0	1.03 V	65	26.30	35.70
2	2384.00	51.8 AV	54.0	-2.2	1.03 V	65	16.10	35.70
3	*2462.00	117.2 PK			1.10 V	30	81.30	35.90
4	*2462.00	113.2 AV			1.10 V	30	77.30	35.90
5	2483.50	64.0 PK	74.0	-10.0	1.10 V	30	28.10	35.90
6	2483.50	52.8 AV	54.0	-1.2	1.10 V	30	16.90	35.90
7	4924.00	52.0 PK	74.0	-22.0	1.20 V	340	8.60	43.40
8	4924.00	45.1 AV	54.0	-8.9	1.20 V	340	1.70	43.40
9	5150.00	59.4 PK	74.0	-14.6	1.10 V	184	15.60	43.80
10	5150.00	46.5 AV	54.0	-7.5	1.10 V	184	2.70	43.80
11	*5180.00	105.4 PK			1.00 V	20	61.50	43.90
12	*5180.00	95.4 AV			1.00 V	20	51.50	43.90
13	#10360.00	56.2 PK	74.0	-17.8	1.10 V	60	5.30	50.90
14	#10360.00	43.0 AV	54.0	-11.0	1.10 V	60	-7.90	50.90

REMARKS:

1. Emission level (dBuV/m) = Raw Value (dBuV) + Correction Factor (dB/m).
2. Correction Factor (dB/m) = Antenna Factor (dB/m) + Cable Factor (dB).
3. The other emission levels were very low against the limit.
4. Margin value = Emission level – Limit value.
5. “ * “: Fundamental frequency.
6. "#":The radiated frequency is out the restricted band.



A D T

802.11b + 802.11n (20MHz)

EUT TEST CONDITION		MEASUREMENT DETAIL	
CHANNEL	CH 11 + CH 157	FREQUENCY RANGE	1 ~ 25GHz
INPUT POWER	120Vac, 60Hz	DETECTOR FUNCTION	Peak (PK) Average (AV)
ENVIRONMENTAL CONDITIONS	25deg. C, 65%RH	TESTED BY	Chris Lin

ANTENNA POLARITY & TEST DISTANCE: HORIZONTAL AT 3 M								
NO.	FREQ. (MHz)	EMISSION LEVEL (dBuV/m)	LIMIT (dBuV/m)	MARGIN (dB)	ANTENNA HEIGHT (m)	TABLE ANGLE (Degree)	RAW VALUE (dBuV)	CORRECTION FACTOR (dB/m)
1	*2462.00	100.4 PK			1.42 H	85	64.50	35.90
2	*2462.00	97.1 AV			1.42 H	85	61.20	35.90
3	2483.50	59.9 PK	74.0	-14.1	1.03 H	228	24.00	35.90
4	2483.50	48.0 AV	54.0	-6.0	1.03 H	228	12.10	35.90
5	4924.00	49.4 PK	74.0	-24.6	1.02 H	336	6.00	43.40
6	4924.00	38.2 AV	54.0	-15.8	1.02 H	336	-5.20	43.40
7	*5785.00	101.5 PK			1.00 H	50	56.80	44.70
8	*5785.00	92.0 AV			1.00 H	50	47.30	44.70
9	11570.00	57.4 PK	74.0	-16.6	1.40 H	60	4.60	52.80
10	11570.00	45.2 AV	54.0	-8.8	1.40 H	60	-7.60	52.80
11	#17355.00	64.0 PK	81.5	-17.5	1.20 H	302	4.00	60.00
12	#17355.00	50.5 AV	72.0	-21.5	1.20 H	302	-9.50	60.00

REMARKS:

1. Emission level (dBuV/m) = Raw Value (dBuV) + Correction Factor (dB/m).
2. Correction Factor (dB/m) = Antenna Factor (dB/m) + Cable Factor (dB).
3. The other emission levels were very low against the limit.
4. Margin value = Emission level – Limit value.
5. “ * “: Fundamental frequency.
6. "#":The radiated frequency is out the restricted band.



A D T

EUT TEST CONDITION		MEASUREMENT DETAIL	
CHANNEL	CH 11 + CH 157	FREQUENCY RANGE	1 ~ 25GHz
INPUT POWER	120Vac, 60Hz	DETECTOR FUNCTION	Peak (PK) Average (AV)
ENVIRONMENTAL CONDITIONS	25deg. C, 65%RH	TESTED BY	Chris Lin

ANTENNA POLARITY & TEST DISTANCE: VERTICAL AT 3 M								
NO.	FREQ. (MHz)	EMISSION LEVEL (dBuV/m)	LIMIT (dBuV/m)	MARGIN (dB)	ANTENNA HEIGHT (m)	TABLE ANGLE (Degree)	RAW VALUE (dBuV)	CORRECTION FACTOR (dB/m)
1	2384.00	61.2 PK	74.0	-12.8	1.03 V	360	25.50	35.70
2	2384.00	51.5 AV	54.0	-2.5	1.03 V	360	15.80	35.70
3	*2462.00	117.0 PK			1.03 V	65	81.10	35.90
4	*2462.00	113.1 AV			1.03 V	65	77.20	35.90
5	2483.50	63.8 PK	74.0	-10.2	1.13 V	209	27.90	35.90
6	2483.50	52.6 AV	54.0	-1.4	1.13 V	209	16.70	35.90
7	4924.00	52.1 PK	74.0	-21.9	1.09 V	210	8.70	43.40
8	4924.00	45.0 AV	54.0	-9.0	1.09 V	210	1.60	43.40
9	*5785.00	111.5 PK			1.20 V	10	66.80	44.70
10	*5785.00	101.2 AV			1.20 V	10	56.50	44.70
11	11570.00	60.0 PK	74.0	-14.0	1.30 V	208	7.20	52.80
12	11570.00	47.4 AV	54.0	-6.6	1.30 V	208	-5.40	52.80
13	#17355.00	65.5 PK	91.5	-26.0	1.03 V	222	5.50	60.00
14	#17355.00	52.1 AV	81.2	-29.1	1.03 V	222	-7.90	60.00

REMARKS:

1. Emission level (dBuV/m) = Raw Value (dBuV) + Correction Factor (dB/m).
2. Correction Factor (dB/m) = Antenna Factor (dB/m) + Cable Factor (dB).
3. The other emission levels were very low against the limit.
4. Margin value = Emission level – Limit value.
5. “ * “: Fundamental frequency.
6. "#":The radiated frequency is out the restricted band.



A D T

TEST MODE D

802.11g + 802.11n (20MHz)

EUT TEST CONDITION		MEASUREMENT DETAIL	
CHANNEL	CH 6 + CH 48	FREQUENCY RANGE	1 ~ 25GHz
INPUT POWER	120Vac, 60Hz	DETECTOR FUNCTION	Peak (PK) Average (AV)
ENVIRONMENTAL CONDITIONS	25deg. C, 65%RH	TESTED BY	Chris Lin

ANTENNA POLARITY & TEST DISTANCE: HORIZONTAL AT 3 M								
NO.	FREQ. (MHz)	EMISSION LEVEL (dBuV/m)	LIMIT (dBuV/m)	MARGIN (dB)	ANTENNA HEIGHT (m)	TABLE ANGLE (Degree)	RAW VALUE (dBuV)	CORRECTION FACTOR (dB/m)
1	2390.00	59.3 PK	74.0	-14.7	1.02 H	302	23.60	35.70
2	2390.00	48.3 AV	54.0	-5.7	1.02 H	302	12.60	35.70
3	*2437.00	112.0 PK			1.03 H	222	76.20	35.80
4	*2437.00	102.3 AV			1.03 H	222	66.50	35.80
5	2483.50	60.0 PK	74.0	-14.0	1.23 H	65	24.10	35.90
6	2483.50	49.0 AV	54.0	-5.0	1.23 H	65	13.10	35.90
7	4874.00	51.5 PK	74.0	-22.5	1.10 H	221	8.30	43.20
8	4874.00	38.0 AV	54.0	-16.0	1.10 H	221	-5.20	43.20
9	*5240.00	101.0 PK			1.25 H	270	57.00	44.00
10	*5240.00	91.0 AV			1.25 H	270	47.00	44.00
11	5350.00	59.4 PK	74.0	-14.6	1.02 H	330	15.30	44.10
12	5350.00	45.9 AV	54.0	-8.1	1.02 H	330	1.80	44.10
13	#10480.00	56.5 PK	74.0	-17.5	1.02 H	332	5.30	51.20
14	#10480.00	44.5 AV	54.0	-9.5	1.02 H	332	-6.70	51.20

REMARKS:

1. Emission level (dBuV/m) = Raw Value (dBuV) + Correction Factor (dB/m).
2. Correction Factor (dB/m) = Antenna Factor (dB/m) + Cable Factor (dB).
3. The other emission levels were very low against the limit.
4. Margin value = Emission level – Limit value.
5. “ * “: Fundamental frequency.
6. "#":The radiated frequency is out the restricted band.



A D T

EUT TEST CONDITION		MEASUREMENT DETAIL	
CHANNEL	CH 6 + CH 48	FREQUENCY RANGE	1 ~ 25GHz
INPUT POWER	120Vac, 60Hz	DETECTOR FUNCTION	Peak (PK) Average (AV)
ENVIRONMENTAL CONDITIONS	25deg. C, 65%RH	TESTED BY	Chris Lin

ANTENNA POLARITY & TEST DISTANCE: VERTICAL AT 3 M								
NO.	FREQ. (MHz)	EMISSION LEVEL (dBuV/m)	LIMIT (dBuV/m)	MARGIN (dB)	ANTENNA HEIGHT (m)	TABLE ANGLE (Degree)	RAW VALUE (dBuV)	CORRECTION FACTOR (dB/m)
1	2390.00	65.2 PK	74.0	-8.8	1.10 V	20	29.50	35.70
2	2390.00	52.1 AV	54.0	-1.9	1.10 V	20	16.40	35.70
3	*2437.00	118.5 PK			1.02 V	35	82.70	35.80
4	*2437.00	108.2 AV			1.02 V	35	72.40	35.80
5	2483.50	67.5 PK	74.0	-6.5	1.08 V	55	31.60	35.90
6	2483.50	52.7 AV	54.0	-1.3	1.08 V	55	16.80	35.90
7	4874.00	56.4 PK	74.0	-17.6	1.33 V	222	13.20	43.20
8	4874.00	41.0 AV	54.0	-13.0	1.33 V	222	-2.20	43.20
9	*5240.00	107.2 PK			2.00 V	240	63.20	44.00
10	*5240.00	97.2 AV			2.00 V	240	53.20	44.00
11	5350.00	61.5 PK	74.0	-12.5	1.02 V	123	17.40	44.10
12	5350.00	48.5 AV	54.0	-5.5	1.02 V	123	4.40	44.10
13	#10480.00	58.4 PK	74.0	-15.6	1.09 V	308	7.20	51.20
14	#10480.00	46.2 AV	54.0	-7.8	1.09 V	308	-5.00	51.20

REMARKS:

1. Emission level (dBuV/m) = Raw Value (dBuV) + Correction Factor (dB/m).
2. Correction Factor (dB/m) = Antenna Factor (dB/m) + Cable Factor (dB).
3. The other emission levels were very low against the limit.
4. Margin value = Emission level – Limit value.
5. “ * “: Fundamental frequency.
6. "#":The radiated frequency is out the restricted band.



A D T

802.11g + 802.11a

EUT TEST CONDITION		MEASUREMENT DETAIL	
CHANNEL	CH 6 + CH 165	FREQUENCY RANGE	1 ~ 25GHz
INPUT POWER	120Vac, 60Hz	DETECTOR FUNCTION	Peak (PK) Average (AV)
ENVIRONMENTAL CONDITIONS	25deg. C, 65%RH	TESTED BY	Chris Lin

ANTENNA POLARITY & TEST DISTANCE: HORIZONTAL AT 3 M								
NO.	FREQ. (MHz)	EMISSION LEVEL (dBuV/m)	LIMIT (dBuV/m)	MARGIN (dB)	ANTENNA HEIGHT (m)	TABLE ANGLE (Degree)	RAW VALUE (dBuV)	CORRECTION FACTOR (dB/m)
1	2390.00	59.2 PK	74.0	-14.8	1.20 H	332	23.50	35.70
2	2390.00	48.4 AV	54.0	-5.6	1.20 H	332	12.70	35.70
3	*2437.00	112.0 PK			1.10 H	41	76.20	35.80
4	*2437.00	102.3 AV			1.10 H	41	66.50	35.80
5	2483.50	60.2 PK	74.0	-13.8	1.20 H	330	24.30	35.90
6	2483.50	49.0 AV	54.0	-5.0	1.20 H	330	13.10	35.90
7	4874.00	51.2 PK	74.0	-22.8	1.23 H	201	8.00	43.20
8	4874.00	38.0 AV	54.0	-16.0	1.23 H	201	-5.20	43.20
9	*5825.00	101.5 PK			1.00 H	20	56.70	44.80
10	*5825.00	91.2 AV			1.00 H	20	46.40	44.80
11	#5850.00	62.2 PK	81.5	-19.3	1.80 H	310	17.30	44.90
12	#5850.00	52.0 AV	71.2	-19.2	1.80 H	310	7.10	44.90
13	11650.00	58.0 PK	74.0	-16.0	1.10 H	85	5.00	53.00
14	11650.00	45.2 AV	54.0	-8.8	1.10 H	85	-7.80	53.00

REMARKS:

1. Emission level (dBuV/m) = Raw Value (dBuV) + Correction Factor (dB/m).
2. Correction Factor (dB/m) = Antenna Factor (dB/m) + Cable Factor (dB).
3. The other emission levels were very low against the limit.
4. Margin value = Emission level – Limit value.
5. “ * “: Fundamental frequency.
6. “#“: The radiated frequency is out the restricted band.



A D T

EUT TEST CONDITION		MEASUREMENT DETAIL	
CHANNEL	CH 6 + CH 165	FREQUENCY RANGE	1 ~ 25GHz
INPUT POWER	120Vac, 60Hz	DETECTOR FUNCTION	Peak (PK) Average (AV)
ENVIRONMENTAL CONDITIONS	25deg. C, 65%RH	TESTED BY	Chris Lin

ANTENNA POLARITY & TEST DISTANCE: VERTICAL AT 3 M								
NO.	FREQ. (MHz)	EMISSION LEVEL (dBuV/m)	LIMIT (dBuV/m)	MARGIN (dB)	ANTENNA HEIGHT (m)	TABLE ANGLE (Degree)	RAW VALUE (dBuV)	CORRECTION FACTOR (dB/m)
1	2390.00	65.1 PK	74.0	-8.9	1.03 V	225	29.40	35.70
2	2390.00	52.2 AV	54.0	-1.8	1.03 V	225	16.50	35.70
3	*2437.00	118.4 PK			1.36 V	74	82.60	35.80
4	*2437.00	108.2 AV			1.36 V	74	72.40	35.80
5	2483.50	67.4 PK	74.0	-6.6	1.03 V	227	31.50	35.90
6	2483.50	52.1 AV	54.0	-1.9	1.03 V	227	16.20	35.90
7	4874.00	56.2 PK	74.0	-17.8	1.13 V	47	13.00	43.20
8	4874.00	40.2 AV	54.0	-13.8	1.13 V	47	-3.00	43.20
9	*5825.00	111.2 PK			1.50 V	20	66.40	44.80
10	*5825.00	101.2 AV			1.50 V	20	56.40	44.80
11	#5850.00	72.0 PK	91.2	-19.2	1.80 V	310	27.10	44.90
12	#5850.00	62.0 AV	81.2	-19.2	1.80 V	310	17.10	44.90
13	11650.00	60.0 PK	74.0	-14.0	1.10 V	70	7.00	53.00
14	11650.00	47.8 AV	54.0	-6.2	1.10 V	70	-5.20	53.00

REMARKS:

1. Emission level (dBuV/m) = Raw Value (dBuV) + Correction Factor (dB/m).
2. Correction Factor (dB/m) = Antenna Factor (dB/m) + Cable Factor (dB).
3. The other emission levels were very low against the limit.
4. Margin value = Emission level – Limit value.
5. “ * “: Fundamental frequency.
6. "#":The radiated frequency is out the restricted band.



A D T

TEST MODE E

802.11g + 802.11n (20MHz)

EUT TEST CONDITION		MEASUREMENT DETAIL	
CHANNEL	CH 6 + CH 40	FREQUENCY RANGE	1 ~ 25GHz
INPUT POWER	120Vac, 60Hz	DETECTOR FUNCTION	Peak (PK) Average (AV)
ENVIRONMENTAL CONDITIONS	25deg. C, 65%RH	TESTED BY	Chris Lin

ANTENNA POLARITY & TEST DISTANCE: HORIZONTAL AT 3 M								
NO.	FREQ. (MHz)	EMISSION LEVEL (dBuV/m)	LIMIT (dBuV/m)	MARGIN (dB)	ANTENNA HEIGHT (m)	TABLE ANGLE (Degree)	RAW VALUE (dBuV)	CORRECTION FACTOR (dB/m)
1	2390.00	62.5 PK	74.0	-11.5	1.03 H	20	26.80	35.70
2	2390.00	51.0 AV	54.0	-3.0	1.03 H	20	15.30	35.70
3	*2437.00	119.8 PK			1.25 H	166	84.00	35.80
4	*2437.00	110.4 AV			1.25 H	166	74.60	35.80
5	2483.50	65.4 PK	74.0	-8.6	1.03 H	0	29.50	35.90
6	2483.50	52.6 AV	54.0	-1.4	1.03 H	0	16.70	35.90
7	4874.00	52.3 PK	74.0	-21.7	1.10 H	302	9.10	43.20
8	4874.00	38.4 AV	54.0	-15.6	1.10 H	302	-4.80	43.20
9	*5200.00	106.2 PK			1.10 H	350	62.30	43.90
10	*5200.00	96.0 AV			1.10 H	350	52.10	43.90
11	7311.00	55.0 PK	74.0	-19.0	1.23 H	95	7.30	47.70
12	7311.00	41.5 AV	54.0	-12.5	1.23 H	95	-6.20	47.70
13	#10400.00	56.0 PK	74.0	-18.0	1.10 H	330	5.10	50.90
14	#10400.00	45.0 AV	54.0	-9.0	1.10 H	330	-5.90	50.90

REMARKS:

1. Emission level (dBuV/m) = Raw Value (dBuV) + Correction Factor (dB/m).
2. Correction Factor (dB/m) = Antenna Factor (dB/m) + Cable Factor (dB).
3. The other emission levels were very low against the limit.
4. Margin value = Emission level – Limit value.
5. “ * “: Fundamental frequency.
6. “#”:The radiated frequency is out the restricted band.



A D T

EUT TEST CONDITION		MEASUREMENT DETAIL	
CHANNEL	CH 6 + CH 40	FREQUENCY RANGE	1 ~ 25GHz
INPUT POWER	120Vac, 60Hz	DETECTOR FUNCTION	Peak (PK) Average (AV)
ENVIRONMENTAL CONDITIONS	25deg. C, 65%RH	TESTED BY	Chris Lin

ANTENNA POLARITY & TEST DISTANCE: VERTICAL AT 3 M								
NO.	FREQ. (MHz)	EMISSION LEVEL (dBuV/m)	LIMIT (dBuV/m)	MARGIN (dB)	ANTENNA HEIGHT (m)	TABLE ANGLE (Degree)	RAW VALUE (dBuV)	CORRECTION FACTOR (dB/m)
1	*2437.00	117.8 PK			1.35 V	30	82.00	35.80
2	*2437.00	107.2 AV			1.35 V	30	71.40	35.80
3	2483.50	66.0 PK	74.0	-8.0	1.03 V	65	30.10	35.90
4	2483.50	52.1 AV	54.0	-1.9	1.03 V	65	16.20	35.90
5	4874.00	53.5 PK	74.0	-20.5	1.30 V	47	10.30	43.20
6	4874.00	40.0 AV	54.0	-14.0	1.30 V	47	-3.20	43.20
7	*5200.00	110.5 PK			1.08 V	22	66.60	43.90
8	*5200.00	100.6 AV			1.08 V	22	56.70	43.90
9	7311.00	56.5 PK	74.0	-17.5	1.13 V	98	8.80	47.70
10	7311.00	42.5 AV	54.0	-11.5	1.13 V	98	-5.20	47.70
11	#10400.00	58.0 PK	74.0	-16.0	1.42 V	178	7.10	50.90
12	#10400.00	45.0 AV	54.0	-9.0	1.42 V	178	-5.90	50.90

REMARKS:

1. Emission level (dBuV/m) = Raw Value (dBuV) + Correction Factor (dB/m).
2. Correction Factor (dB/m) = Antenna Factor (dB/m) + Cable Factor (dB).
3. The other emission levels were very low against the limit.
4. Margin value = Emission level – Limit value.
5. “ * “: Fundamental frequency.
6. “#”: The radiated frequency is out the restricted band.



A D T

802.11g + 802.11a

EUT TEST CONDITION		MEASUREMENT DETAIL	
CHANNEL	CH 6 + CH 157	FREQUENCY RANGE	1 ~ 25GHz
INPUT POWER	120Vac, 60Hz	DETECTOR FUNCTION	Peak (PK) Average (AV)
ENVIRONMENTAL CONDITIONS	25deg. C, 65%RH	TESTED BY	Chris Lin

ANTENNA POLARITY & TEST DISTANCE: HORIZONTAL AT 3 M								
NO.	FREQ. (MHz)	EMISSION LEVEL (dBuV/m)	LIMIT (dBuV/m)	MARGIN (dB)	ANTENNA HEIGHT (m)	TABLE ANGLE (Degree)	RAW VALUE (dBuV)	CORRECTION FACTOR (dB/m)
1	2390.00	62.0 PK	74.0	-12.0	1.02 H	309	26.30	35.70
2	2390.00	51.0 AV	54.0	-3.0	1.02 H	309	15.30	35.70
3	*2437.00	119.5 PK			1.03 H	62	83.70	35.80
4	*2437.00	110.1 AV			1.03 H	62	74.30	35.80
5	2483.50	65.0 PK	74.0	-9.0	1.23 H	87	29.10	35.90
6	2483.50	52.0 AV	54.0	-2.0	1.23 H	87	16.10	35.90
7	4874.00	52.3 PK	74.0	-21.7	1.32 H	87	9.10	43.20
8	4874.00	38.4 AV	54.0	-15.6	1.32 H	87	-4.80	43.20
9	5440.00	55.0 PK	74.0	-19.0	1.10 H	230	10.80	44.20
10	5440.00	47.5 AV	54.0	-6.5	1.10 H	230	3.30	44.20
11	*5785.00	113.0 PK			1.22 H	8	68.30	44.70
12	*5785.00	103.0 AV			1.22 H	8	58.30	44.70
13	7311.00	54.8 PK	74.0	-19.2	1.00 H	123	7.10	47.70
14	7311.00	41.0 AV	54.0	-13.0	1.00 H	123	-6.70	47.70
15	11570.00	55.5 PK	74.0	-18.5	1.40 H	300	2.70	52.80
16	11570.00	45.8 AV	54.0	-8.2	1.40 H	300	-7.00	52.80

REMARKS:

1. Emission level (dBuV/m) = Raw Value (dBuV) + Correction Factor (dB/m).
2. Correction Factor (dB/m) = Antenna Factor (dB/m) + Cable Factor (dB).
3. The other emission levels were very low against the limit.
4. Margin value = Emission level – Limit value.
5. “ * “: Fundamental frequency.
6. "#":The radiated frequency is out the restricted band.



A D T

EUT TEST CONDITION		MEASUREMENT DETAIL	
CHANNEL	CH 6 + CH 157	FREQUENCY RANGE	1 ~ 25GHz
INPUT POWER	120Vac, 60Hz	DETECTOR FUNCTION	Peak (PK) Average (AV)
ENVIRONMENTAL CONDITIONS	25deg. C, 65%RH	TESTED BY	Chris Lin

ANTENNA POLARITY & TEST DISTANCE: VERTICAL AT 3 M								
NO.	FREQ. (MHz)	EMISSION LEVEL (dBuV/m)	LIMIT (dBuV/m)	MARGIN (dB)	ANTENNA HEIGHT (m)	TABLE ANGLE (Degree)	RAW VALUE (dBuV)	CORRECTION FACTOR (dB/m)
1	*2437.00	117.5 PK			1.40 V	50	81.70	35.80
2	*2437.00	107.7 AV			1.40 V	50	71.90	35.80
3	2483.50	66.0 PK	74.0	-8.0	1.03 V	201	30.10	35.90
4	2483.50	52.0 AV	54.0	-2.0	1.03 V	201	16.10	35.90
5	4874.00	53.2 PK	74.0	-20.8	1.03 V	269	10.00	43.20
6	4874.00	40.1 AV	54.0	-13.9	1.03 V	269	-3.10	43.20
7	5440.00	59.0 PK	74.0	-15.0	1.36 V	98	14.80	44.20
8	5440.00	50.0 AV	54.0	-4.0	1.36 V	98	5.80	44.20
9	*5785.00	116.2 PK			1.30 V	30	71.50	44.70
10	*5785.00	106.2 AV			1.30 V	30	61.50	44.70
11	7311.00	56.2 PK	74.0	-17.8	1.33 V	201	8.50	47.70
12	7311.00	42.0 AV	54.0	-12.0	1.33 V	201	-5.70	47.70
13	11570.00	57.2 PK	74.0	-16.8	1.07 V	41	4.40	52.80
14	11570.00	46.3 AV	54.0	-7.7	1.07 V	41	-6.50	52.80

REMARKS:

1. Emission level (dBuV/m) = Raw Value (dBuV) + Correction Factor (dB/m).
2. Correction Factor (dB/m) = Antenna Factor (dB/m) + Cable Factor (dB).
3. The other emission levels were very low against the limit.
4. Margin value = Emission level – Limit value.
5. “ * “: Fundamental frequency.
6. "#":The radiated frequency is out the restricted band.



A D T

BELOW 1GHz DATA :

TEST MODE A

802.11n (20MHz) + 802.11n (40MHz)

EUT TEST CONDITION		MEASUREMENT DETAIL	
CHANNEL	CH 6 + CH 46	FREQUENCY RANGE	Below 1000MHz
INPUT POWER (SYSTEM)	120Vac, 60Hz	DETECTOR FUNCTION	Quasi-Peak
ENVIRONMENTAL CONDITIONS	25deg. C, 65%RH	TESTED BY	Haru Yang

ANTENNA POLARITY & TEST DISTANCE: HORIZONTAL AT 3 M								
NO.	FREQ. (MHz)	EMISSION LEVEL (dBuV/m)	LIMIT (dBuV/m)	MARGIN (dB)	ANTENNA HEIGHT (m)	TABLE ANGLE (Degree)	RAW VALUE (dBuV)	CORRECTION FACTOR (dB/m)
1	100.02	33.6 QP	43.5	-9.9	1.50 H	159	24.20	9.40
2	167.77	38.4 QP	43.5	-5.1	1.51 H	36	24.70	13.70
3	200.03	36.4 QP	43.5	-7.1	1.00 H	188	25.40	11.00
4	299.36	43.0 QP	46.0	-3.0	1.00 H	147	28.10	14.90
5	666.02	37.4 QP	46.0	-8.6	1.00 H	147	14.70	22.70
6	700.01	42.5 QP	46.0	-3.5	1.00 H	206	19.50	23.00

ANTENNA POLARITY & TEST DISTANCE: VERTICAL AT 3 M								
NO.	FREQ. (MHz)	EMISSION LEVEL (dBuV/m)	LIMIT (dBuV/m)	MARGIN (dB)	ANTENNA HEIGHT (m)	TABLE ANGLE (Degree)	RAW VALUE (dBuV)	CORRECTION FACTOR (dB/m)
1	100.02	32.3 QP	43.5	-11.2	1.00 V	58	22.90	9.40
2	300.25	37.6 QP	46.0	-8.4	1.51 V	112	22.60	15.00
3	336.24	33.6 QP	46.0	-12.4	1.51 V	179	17.70	15.90
4	664.68	34.2 QP	46.0	-11.8	1.00 V	59	11.50	22.70
5	697.88	36.4 QP	46.0	-9.6	1.00 V	151	13.40	23.00
6	900.03	37.5 QP	46.0	-8.5	1.51 V	99	10.70	26.80

REMARKS:

1. Emission level (dBuV/m) = Raw Value (dBuV) + Correction Factor (dB/m).
2. Correction Factor (dB/m) = Antenna Factor (dB/m) + Cable Factor (dB).
3. The other emission levels were very low against the limit.
4. Margin value = Emission level – Limit value.



A D T

802.11n (20MHz) + 802.11n (20MHz)

EUT TEST CONDITION		MEASUREMENT DETAIL	
CHANNEL	CH 6 + CH 149	FREQUENCY RANGE	Below 1000MHz
INPUT POWER (SYSTEM)	120Vac, 60Hz	DETECTOR FUNCTION	Quasi-Peak
ENVIRONMENTAL CONDITIONS	25deg. C, 65%RH	TESTED BY	Haru Yang

ANTENNA POLARITY & TEST DISTANCE: HORIZONTAL AT 3 M								
NO.	FREQ. (MHz)	EMISSION LEVEL (dBuV/m)	LIMIT (dBuV/m)	MARGIN (dB)	ANTENNA HEIGHT (m)	TABLE ANGLE (Degree)	RAW VALUE (dBuV)	CORRECTION FACTOR (dB/m)
1	100.58	34.6 QP	43.5	-8.9	1.50 H	42	25.10	9.50
2	167.35	40.2 QP	43.5	-3.3	1.51 H	15	26.50	13.70
3	200.03	35.8 QP	43.5	-7.7	1.00 H	215	24.80	11.00
4	299.36	42.8 QP	46.0	-3.2	1.00 H	159	27.90	14.90
5	666.03	38.4 QP	46.0	-7.6	1.00 H	47	15.70	22.70
6	700.66	42.6 QP	46.0	-3.4	1.00 H	191	19.60	23.00
ANTENNA POLARITY & TEST DISTANCE: VERTICAL AT 3 M								
NO.	FREQ. (MHz)	EMISSION LEVEL (dBuV/m)	LIMIT (dBuV/m)	MARGIN (dB)	ANTENNA HEIGHT (m)	TABLE ANGLE (Degree)	RAW VALUE (dBuV)	CORRECTION FACTOR (dB/m)
1	99.36	32.3 QP	43.5	-11.2	1.00 V	56	22.90	9.40
2	300.25	38.6 QP	46.0	-7.4	1.51 V	115	23.60	15.00
3	336.80	33.5 QP	46.0	-12.5	1.50 V	169	17.60	15.90
4	665.02	34.3 QP	46.0	-11.7	1.00 V	17	11.60	22.70
5	697.85	37.5 QP	46.0	-8.5	1.00 V	147	14.50	23.00
6	900.02	37.5 QP	46.0	-8.5	1.50 V	99	10.70	26.80

REMARKS:

1. Emission level (dBuV/m) = Raw Value (dBuV) + Correction Factor (dB/m).
2. Correction Factor (dB/m) = Antenna Factor (dB/m) + Cable Factor (dB).
3. The other emission levels were very low against the limit.
4. Margin value = Emission level – Limit value.



A D T

TEST MODE B

802.11b + 802.11a

EUT TEST CONDITION		MEASUREMENT DETAIL	
CHANNEL	CH 6 + CH 40	FREQUENCY RANGE	Below 1000MHz
INPUT POWER	120Vac, 60Hz	DETECTOR FUNCTION	Quasi-Peak
ENVIRONMENTAL CONDITIONS	25deg. C, 65%RH	TESTED BY	Chris Lin

ANTENNA POLARITY & TEST DISTANCE: HORIZONTAL AT 3 M								
NO.	FREQ. (MHz)	EMISSION LEVEL (dBuV/m)	LIMIT (dBuV/m)	MARGIN (dB)	ANTENNA HEIGHT (m)	TABLE ANGLE (Degree)	RAW VALUE (dBuV)	CORRECTION FACTOR (dB/m)
1	107.60	29.4 QP	43.5	-14.1	1.24 H	143	18.90	10.50
2	198.78	28.6 QP	43.5	-14.9	1.00 H	283	18.00	10.60
3	299.66	31.6 QP	46.0	-14.4	1.50 H	211	17.10	14.50
4	375.32	28.8 QP	46.0	-17.2	1.00 H	332	12.20	16.60
5	625.58	33.8 QP	46.0	-12.2	1.24 H	228	11.10	22.70
6	751.68	32.7 QP	46.0	-13.3	1.50 H	202	8.10	24.60
ANTENNA POLARITY & TEST DISTANCE: VERTICAL AT 3 M								
NO.	FREQ. (MHz)	EMISSION LEVEL (dBuV/m)	LIMIT (dBuV/m)	MARGIN (dB)	ANTENNA HEIGHT (m)	TABLE ANGLE (Degree)	RAW VALUE (dBuV)	CORRECTION FACTOR (dB/m)
1	30.00	33.7 QP	40.0	-6.3	1.24 V	221	21.30	12.40
2	99.84	35.9 QP	43.5	-7.6	1.00 V	182	26.10	9.80
3	150.28	30.1 QP	43.5	-13.4	1.50 V	95	16.70	13.40
4	249.22	27.9 QP	46.0	-18.1	1.00 V	198	15.10	12.80
5	499.48	34.5 QP	46.0	-11.5	1.24 V	195	14.70	19.80
6	868.08	32.4 QP	46.0	-13.6	1.50 V	195	6.00	26.40

REMARKS:

1. Emission level (dBuV/m) = Raw Value (dBuV) + Correction Factor (dB/m).
2. Correction Factor (dB/m) = Antenna Factor (dB/m) + Cable Factor (dB).
3. The other emission levels were very low against the limit.
4. Margin value = Emission level – Limit value.



A D T

802.11b + 802.11a

EUT TEST CONDITION		MEASUREMENT DETAIL	
CHANNEL	CH 6 + CH 157	FREQUENCY RANGE	Below 1000MHz
INPUT POWER	120Vac, 60Hz	DETECTOR FUNCTION	Quasi-Peak
ENVIRONMENTAL CONDITIONS	25deg. C, 65%RH	TESTED BY	Chris Lin

ANTENNA POLARITY & TEST DISTANCE: HORIZONTAL AT 3 M								
NO.	FREQ. (MHz)	EMISSION LEVEL (dBuV/m)	LIMIT (dBuV/m)	MARGIN (dB)	ANTENNA HEIGHT (m)	TABLE ANGLE (Degree)	RAW VALUE (dBuV)	CORRECTION FACTOR (dB/m)
1	107.60	29.3 QP	43.5	-14.2	1.24 H	135	18.80	10.50
2	249.22	31.2 QP	46.0	-14.8	1.00 H	159	18.40	12.80
3	299.66	29.0 QP	46.0	-17.0	1.50 H	229	14.50	14.50
4	332.64	28.0 QP	46.0	-18.0	1.00 H	318	12.60	15.40
5	625.58	34.1 QP	46.0	-11.9	1.24 H	228	11.40	22.70
6	751.68	34.1 QP	46.0	-11.9	1.50 H	218	9.50	24.60
ANTENNA POLARITY & TEST DISTANCE: VERTICAL AT 3 M								
NO.	FREQ. (MHz)	EMISSION LEVEL (dBuV/m)	LIMIT (dBuV/m)	MARGIN (dB)	ANTENNA HEIGHT (m)	TABLE ANGLE (Degree)	RAW VALUE (dBuV)	CORRECTION FACTOR (dB/m)
1	30.00	30.8 QP	40.0	-9.2	1.24 V	282	18.40	12.40
2	99.84	36.4 QP	43.5	-7.1	1.00 V	198	26.60	9.80
3	150.28	31.1 QP	43.5	-12.4	1.50 V	287	17.70	13.40
4	249.22	28.7 QP	46.0	-17.3	1.00 V	209	15.90	12.80
5	499.48	33.0 QP	46.0	-13.0	1.24 V	195	13.20	19.80
6	868.08	32.8 QP	46.0	-13.2	1.50 V	226	6.40	26.40

REMARKS:

1. Emission level (dBuV/m) = Raw Value (dBuV) + Correction Factor (dB/m).
2. Correction Factor (dB/m) = Antenna Factor (dB/m) + Cable Factor (dB).
3. The other emission levels were very low against the limit.
4. Margin value = Emission level – Limit value.



A D T

TEST MODE C

802.11b + 802.11a

EUT TEST CONDITION		MEASUREMENT DETAIL	
CHANNEL	CH 11 + CH 36	FREQUENCY RANGE	Below 1000MHz
INPUT POWER	120Vac, 60Hz	DETECTOR FUNCTION	Quasi-Peak
ENVIRONMENTAL CONDITIONS	25deg. C, 65%RH	TESTED BY	Chris Lin

ANTENNA POLARITY & TEST DISTANCE: HORIZONTAL AT 3 M								
NO.	FREQ. (MHz)	EMISSION LEVEL (dBuV/m)	LIMIT (dBuV/m)	MARGIN (dB)	ANTENNA HEIGHT (m)	TABLE ANGLE (Degree)	RAW VALUE (dBuV)	CORRECTION FACTOR (dB/m)
1	99.84	28.4 QP	43.5	-15.1	1.24 H	235	18.60	9.80
2	198.78	30.7 QP	43.5	-12.8	1.00 H	105	20.10	10.60
3	249.22	35.5 QP	46.0	-10.5	1.50 H	109	22.70	12.80
4	375.32	32.5 QP	46.0	-13.5	1.00 H	246	15.90	16.60
5	625.58	34.7 QP	46.0	-11.3	1.24 H	297	12.00	22.70
6	751.68	35.1 QP	46.0	-10.9	1.50 H	199	10.50	24.60
ANTENNA POLARITY & TEST DISTANCE: VERTICAL AT 3 M								
NO.	FREQ. (MHz)	EMISSION LEVEL (dBuV/m)	LIMIT (dBuV/m)	MARGIN (dB)	ANTENNA HEIGHT (m)	TABLE ANGLE (Degree)	RAW VALUE (dBuV)	CORRECTION FACTOR (dB/m)
1	30.00	36.3 QP	40.0	-3.7	1.24 V	7	23.90	12.40
2	103.72	32.2 QP	43.5	-11.3	1.00 V	279	22.10	10.10
3	175.50	29.2 QP	43.5	-14.3	1.50 V	300	16.50	12.70
4	375.32	32.8 QP	46.0	-13.2	1.00 V	226	16.20	16.60
5	625.58	30.0 QP	46.0	-16.0	1.24 V	213	7.30	22.70
6	802.12	30.9 QP	46.0	-15.1	1.50 V	201	5.50	25.40

REMARKS:

1. Emission level (dBuV/m) = Raw Value (dBuV) + Correction Factor (dB/m).
2. Correction Factor (dB/m) = Antenna Factor (dB/m) + Cable Factor (dB).
3. The other emission levels were very low against the limit.
4. Margin value = Emission level – Limit value.



A D T

802.11b + 802.11n (20MHz)

EUT TEST CONDITION		MEASUREMENT DETAIL	
CHANNEL	CH 11 + CH 157	FREQUENCY RANGE	Below 1000MHz
INPUT POWER	120Vac, 60Hz	DETECTOR FUNCTION	Quasi-Peak
ENVIRONMENTAL CONDITIONS	25deg. C, 65%RH	TESTED BY	Chris Lin

ANTENNA POLARITY & TEST DISTANCE: HORIZONTAL AT 3 M								
NO.	FREQ. (MHz)	EMISSION LEVEL (dBuV/m)	LIMIT (dBuV/m)	MARGIN (dB)	ANTENNA HEIGHT (m)	TABLE ANGLE (Degree)	RAW VALUE (dBuV)	CORRECTION FACTOR (dB/m)
1	99.84	28.0 QP	43.5	-15.5	1.24 H	221	18.20	9.80
2	198.78	29.7 QP	43.5	-13.8	1.00 H	83	19.10	10.60
3	249.22	35.3 QP	46.0	-10.7	1.50 H	107	22.50	12.80
4	375.32	32.0 QP	46.0	-14.0	1.00 H	212	15.40	16.60
5	625.58	33.5 QP	46.0	-12.5	1.24 H	223	10.80	22.70
6	749.74	33.3 QP	46.0	-12.7	1.50 H	182	8.80	24.50
ANTENNA POLARITY & TEST DISTANCE: VERTICAL AT 3 M								
NO.	FREQ. (MHz)	EMISSION LEVEL (dBuV/m)	LIMIT (dBuV/m)	MARGIN (dB)	ANTENNA HEIGHT (m)	TABLE ANGLE (Degree)	RAW VALUE (dBuV)	CORRECTION FACTOR (dB/m)
1	30.00	37.2 QP	40.0	-2.8	1.24 V	89	24.80	12.40
2	43.58	35.6 QP	40.0	-4.4	1.00 V	1	21.60	14.00
3	97.90	32.2 QP	43.5	-11.3	1.50 V	233	22.60	9.60
4	175.50	29.1 QP	43.5	-14.4	1.24 V	311	16.40	12.70
5	375.32	32.0 QP	46.0	-14.0	1.00 V	211	15.40	16.60
6	625.58	28.5 QP	46.0	-17.5	1.50 V	233	5.80	22.70

REMARKS:

1. Emission level (dBuV/m) = Raw Value (dBuV) + Correction Factor (dB/m).
2. Correction Factor (dB/m) = Antenna Factor (dB/m) + Cable Factor (dB).
3. The other emission levels were very low against the limit.
4. Margin value = Emission level – Limit value.



A D T

TEST MODE D

802.11g + 802.11n (20MHz)

EUT TEST CONDITION		MEASUREMENT DETAIL	
CHANNEL	CH 6 + CH 48	FREQUENCY RANGE	Below 1000MHz
INPUT POWER	120Vac, 60Hz	DETECTOR FUNCTION	Quasi-Peak
ENVIRONMENTAL CONDITIONS	25deg. C, 65%RH	TESTED BY	Chris Lin

ANTENNA POLARITY & TEST DISTANCE: HORIZONTAL AT 3 M								
NO.	FREQ. (MHz)	EMISSION LEVEL (dBuV/m)	LIMIT (dBuV/m)	MARGIN (dB)	ANTENNA HEIGHT (m)	TABLE ANGLE (Degree)	RAW VALUE (dBuV)	CORRECTION FACTOR (dB/m)
1	132.82	30.7 QP	43.5	-12.8	1.24 H	95	18.00	12.70
2	198.78	30.4 QP	43.5	-13.1	1.00 H	112	19.80	10.60
3	249.22	34.9 QP	46.0	-11.1	1.50 H	114	22.10	12.80
4	375.32	31.5 QP	46.0	-14.5	1.25 H	225	14.90	16.60
5	625.58	34.2 QP	46.0	-11.8	1.00 H	221	11.50	22.70
6	751.68	33.2 QP	46.0	-12.8	1.50 H	202	8.60	24.60
ANTENNA POLARITY & TEST DISTANCE: VERTICAL AT 3 M								
NO.	FREQ. (MHz)	EMISSION LEVEL (dBuV/m)	LIMIT (dBuV/m)	MARGIN (dB)	ANTENNA HEIGHT (m)	TABLE ANGLE (Degree)	RAW VALUE (dBuV)	CORRECTION FACTOR (dB/m)
1	105.66	33.1 QP	43.5	-10.4	1.24 V	14	22.80	10.30
2	175.50	30.0 QP	43.5	-13.5	1.00 V	89	17.30	12.70
3	375.32	31.2 QP	46.0	-14.8	1.50 V	214	14.60	16.60
4	625.58	29.1 QP	46.0	-16.9	1.00 V	197	6.40	22.70
5	802.12	30.2 QP	46.0	-15.8	1.24 V	127	4.80	25.40
6	875.84	32.0 QP	46.0	-14.0	1.50 V	125	5.50	26.50

REMARKS:

1. Emission level (dBuV/m) = Raw Value (dBuV) + Correction Factor (dB/m).
2. Correction Factor (dB/m) = Antenna Factor (dB/m) + Cable Factor (dB).
3. The other emission levels were very low against the limit.
4. Margin value = Emission level – Limit value.



A D T

802.11g + 802.11a

EUT TEST CONDITION		MEASUREMENT DETAIL	
CHANNEL	CH 6 + CH 165	FREQUENCY RANGE	Below 1000MHz
INPUT POWER	120Vac, 60Hz	DETECTOR FUNCTION	Quasi-Peak
ENVIRONMENTAL CONDITIONS	25deg. C, 65%RH	TESTED BY	Chris Lin

ANTENNA POLARITY & TEST DISTANCE: HORIZONTAL AT 3 M								
NO.	FREQ. (MHz)	EMISSION LEVEL (dBuV/m)	LIMIT (dBuV/m)	MARGIN (dB)	ANTENNA HEIGHT (m)	TABLE ANGLE (Degree)	RAW VALUE (dBuV)	CORRECTION FACTOR (dB/m)
1	99.84	28.6 QP	43.5	-14.9	1.24 H	236	18.80	9.80
2	198.78	30.6 QP	43.5	-12.9	1.50 H	98	20.00	10.60
3	249.22	35.1 QP	46.0	-10.9	1.50 H	110	22.30	12.80
4	375.32	31.9 QP	46.0	-14.1	1.00 H	235	15.30	16.60
5	625.58	33.8 QP	46.0	-12.2	1.24 H	282	11.10	22.70
6	749.74	34.2 QP	46.0	-11.8	1.00 H	184	9.70	24.50
ANTENNA POLARITY & TEST DISTANCE: VERTICAL AT 3 M								
NO.	FREQ. (MHz)	EMISSION LEVEL (dBuV/m)	LIMIT (dBuV/m)	MARGIN (dB)	ANTENNA HEIGHT (m)	TABLE ANGLE (Degree)	RAW VALUE (dBuV)	CORRECTION FACTOR (dB/m)
1	30.00	36.5 QP	40.0	-3.5	1.24 V	72	24.10	12.40
2	103.72	31.8 QP	43.5	-11.7	1.00 V	297	21.70	10.10
3	175.50	29.2 QP	43.5	-14.3	1.50 V	72	16.50	12.70
4	375.32	32.8 QP	46.0	-13.2	1.00 V	207	16.20	16.60
5	625.58	29.2 QP	46.0	-16.8	1.24 V	200	6.50	22.70
6	875.84	32.3 QP	46.0	-13.7	1.50 V	138	5.80	26.50

REMARKS:

1. Emission level (dBuV/m) = Raw Value (dBuV) + Correction Factor (dB/m).
2. Correction Factor (dB/m) = Antenna Factor (dB/m) + Cable Factor (dB).
3. The other emission levels were very low against the limit.
4. Margin value = Emission level – Limit value.



A D T

TEST MODE E

802.11g + 802.11n (20MHz)

EUT TEST CONDITION		MEASUREMENT DETAIL	
CHANNEL	CH 6 + CH 40	FREQUENCY RANGE	Below 1000MHz
INPUT POWER	120Vac, 60Hz	DETECTOR FUNCTION	Quasi-Peak
ENVIRONMENTAL CONDITIONS	25deg. C, 65%RH	TESTED BY	Chris Lin

ANTENNA POLARITY & TEST DISTANCE: HORIZONTAL AT 3 M								
NO.	FREQ. (MHz)	EMISSION LEVEL (dBuV/m)	LIMIT (dBuV/m)	MARGIN (dB)	ANTENNA HEIGHT (m)	TABLE ANGLE (Degree)	RAW VALUE (dBuV)	CORRECTION FACTOR (dB/m)
1	99.84	28.9 QP	43.5	-14.6	1.24 H	241	19.10	9.80
2	198.78	29.7 QP	43.5	-13.8	1.00 H	91	19.10	10.60
3	249.22	35.0 QP	46.0	-11.0	1.50 H	103	22.20	12.80
4	375.32	31.2 QP	46.0	-14.8	1.00 H	134	14.60	16.60
5	625.58	33.7 QP	46.0	-12.3	1.24 H	324	11.00	22.70
6	751.68	35.2 QP	46.0	-10.8	1.50 H	191	10.60	24.60
ANTENNA POLARITY & TEST DISTANCE: VERTICAL AT 3 M								
NO.	FREQ. (MHz)	EMISSION LEVEL (dBuV/m)	LIMIT (dBuV/m)	MARGIN (dB)	ANTENNA HEIGHT (m)	TABLE ANGLE (Degree)	RAW VALUE (dBuV)	CORRECTION FACTOR (dB/m)
1	30.00	36.4 QP	40.0	-3.6	1.24 V	54	24.00	12.40
2	43.58	35.5 QP	40.0	-4.5	1.00 V	73	21.50	14.00
3	103.72	33.7 QP	43.5	-9.8	1.50 V	306	23.60	10.10
4	175.50	29.4 QP	43.5	-14.1	1.24 V	326	16.70	12.70
5	375.32	32.7 QP	46.0	-13.3	1.00 V	202	16.10	16.60
6	625.58	29.1 QP	46.0	-16.9	1.50 V	217	6.40	22.70

REMARKS:

1. Emission level (dBuV/m) = Raw Value (dBuV) + Correction Factor (dB/m).
2. Correction Factor (dB/m) = Antenna Factor (dB/m) + Cable Factor (dB).
3. The other emission levels were very low against the limit.
4. Margin value = Emission level – Limit value.



A D T

802.11g + 802.11a

EUT TEST CONDITION		MEASUREMENT DETAIL	
CHANNEL	CH 6 + CH 157	FREQUENCY RANGE	Below 1000MHz
INPUT POWER	120Vac, 60Hz	DETECTOR FUNCTION	Quasi-Peak
ENVIRONMENTAL CONDITIONS	25deg. C, 65%RH	TESTED BY	Chris Lin

ANTENNA POLARITY & TEST DISTANCE: HORIZONTAL AT 3 M								
NO.	FREQ. (MHz)	EMISSION LEVEL (dBuV/m)	LIMIT (dBuV/m)	MARGIN (dB)	ANTENNA HEIGHT (m)	TABLE ANGLE (Degree)	RAW VALUE (dBuV)	CORRECTION FACTOR (dB/m)
1	107.60	28.8 QP	43.5	-14.7	1.24 H	142	18.30	10.50
2	198.78	28.1 QP	43.5	-15.4	1.00 H	270	17.50	10.60
3	299.66	30.3 QP	46.0	-15.7	1.50 H	225	15.80	14.50
4	375.32	27.6 QP	46.0	-18.4	1.24 H	285	11.00	16.60
5	625.58	33.8 QP	46.0	-12.2	1.00 H	226	11.10	22.70
6	749.74	33.6 QP	46.0	-12.4	1.50 H	217	9.10	24.50
ANTENNA POLARITY & TEST DISTANCE: VERTICAL AT 3 M								
NO.	FREQ. (MHz)	EMISSION LEVEL (dBuV/m)	LIMIT (dBuV/m)	MARGIN (dB)	ANTENNA HEIGHT (m)	TABLE ANGLE (Degree)	RAW VALUE (dBuV)	CORRECTION FACTOR (dB/m)
1	99.84	34.2 QP	43.5	-9.3	1.24 V	176	24.40	9.80
2	253.10	29.3 QP	46.0	-16.7	1.00 V	134	16.40	12.90
3	499.48	32.6 QP	46.0	-13.4	1.50 V	187	12.80	19.80
4	625.58	28.8 QP	46.0	-17.2	1.00 V	38	6.10	22.70
5	749.74	30.3 QP	46.0	-15.7	1.24 V	176	5.80	24.50
6	875.84	31.9 QP	46.0	-14.1	1.50 V	81	5.40	26.50

REMARKS:

1. Emission level (dBuV/m) = Raw Value (dBuV) + Correction Factor (dB/m).
2. Correction Factor (dB/m) = Antenna Factor (dB/m) + Cable Factor (dB).
3. The other emission levels were very low against the limit.
4. Margin value = Emission level – Limit value.



4.2 CONDUCTED EMISSION MEASUREMENT

4.2.1 LIMITS OF CONDUCTED EMISSION MEASUREMENT

FREQUENCY OF EMISSION (MHz)	CONDUCTED LIMIT (dB μ V)	
	Quasi-peak	Average
0.15-0.5	66 to 56	56 to 46
0.5-5	56	46
5-30	60	50

- NOTE:**
1. The lower limit shall apply at the transition frequencies.
 2. The limit decreases in line with the logarithm of the frequency in the range of 0.15 to 0.50 MHz.
 3. All emanations from a class A/B digital device or system, including any network of conductors and apparatus connected thereto, shall not exceed the level of field strengths specified above.

4.2.2 TEST INSTRUMENTS

DESCRIPTION & MANUFACTURER	MODEL NO.	SERIAL NO.	DATE OF CALIBRATION	DUE DATE OF CALIBRATION
Test Receiver ROHDE & SCHWARZ	ESCS30	100288	Nov. 09, 2012	Nov. 08, 2013
RF signal cable Woken	5D-FB	Cable-HYCO2-01	Dec. 28, 2012	Dec. 27, 2013
LISN ROHDE & SCHWARZ (EUT)	ESH2-Z5	100100	Dec. 21, 2012	Dec. 20, 2013
LISN ROHDE & SCHWARZ (Peripheral)	ESH3-Z5	100311	Jul. 06, 2012	Jul. 05, 2013
Software ADT	BV ADT_Cond_ V7.3.7.3	NA	NA	NA

- NOTE:**
1. The calibration interval of the above test instruments is 12 months and the calibrations are traceable to NML/ROC and NIST/USA.
 2. The test was performed in HwaYa Shielded Room 2.
 3. The VCCI Site Registration No. is C-2047.



A D T

4.2.3 TEST PROCEDURES

- a. The EUT was placed 0.4 meters from the conducting wall of the shielded room with EUT being connected to the power mains through a line impedance stabilization network (LISN). Other support units were connected to the power mains through another LISN. The two LISNs provide 50 ohm/ 50uH of coupling impedance for the measuring instrument.
- b. Both lines of the power mains connected to the EUT were checked for maximum conducted interference.
- c. The frequency range from 150kHz to 30MHz was searched. Emission levels under (Limit - 20dB) was not recorded.

NOTE: All modes of operation were investigated and the worst-case emissions are reported.

4.2.4 DEVIATION FROM TEST STANDARD

No deviation.

4.2.5 TEST SETUP

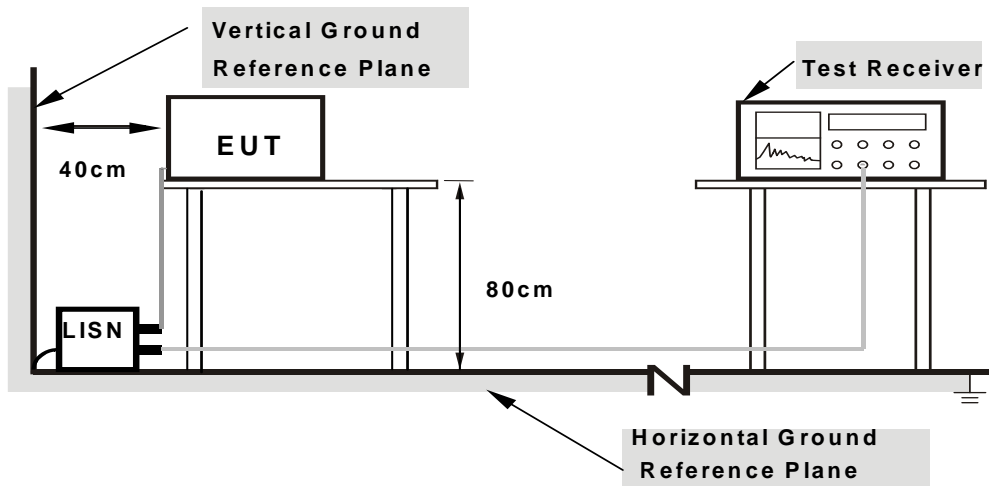

- Note:**
1. Support units were connected to second LISN.
 2. Both of LISNs (AMN) are 80 cm from EUT and at least 80 cm from other units and other metal planes

For the actual test configuration, please refer to the attached file (Test Setup Photo).

4.2.6 EUT OPERATING CONDITIONS

Same as 4.1.6.

4.2.7 TEST RESULTS

CONDUCTED WORST-CASE DATA:

TEST MODE A

802.11n (20MHz) + 802.11n (40MHz)

CHANNEL	CH 6 + CH 46	6dB BANDWIDTH	9kHz
PHASE	Line 1		

No	Freq. [MHz]	Corr. Factor (dB)	Reading Value [dB (uV)]		Emission Level [dB (uV)]		Limit [dB (uV)]		Margin (dB)	
			Q.P.	AV.	Q.P.	AV.	Q.P.	AV.	Q.P.	AV.
			1	0.17412	0.17	29.24	15.39	29.41	15.56	64.76
2	0.47852	0.22	30.14	22.24	30.36	22.46	56.36	46.36	-26.01	-23.91
3	0.51853	0.22	37.18	36.24	37.40	36.46	56.00	46.00	-18.60	-9.54
4	1.96515	0.29	24.17	20.03	24.46	20.32	56.00	46.00	-31.54	-25.68
5	12.96352	0.51	21.57	15.58	22.08	16.09	60.00	50.00	-37.92	-33.91
6	20.27859	0.68	42.11	37.07	42.79	37.75	60.00	50.00	-17.21	-12.25

REMARKS:

1. Q.P. and AV. are abbreviations of quasi-peak and average individually.
2. The emission levels of other frequencies were very low against the limit.
3. Margin value = Emission level - Limit value
4. Correction factor = Insertion loss + Cable loss
5. Emission Level = Correction Factor + Reading Value.

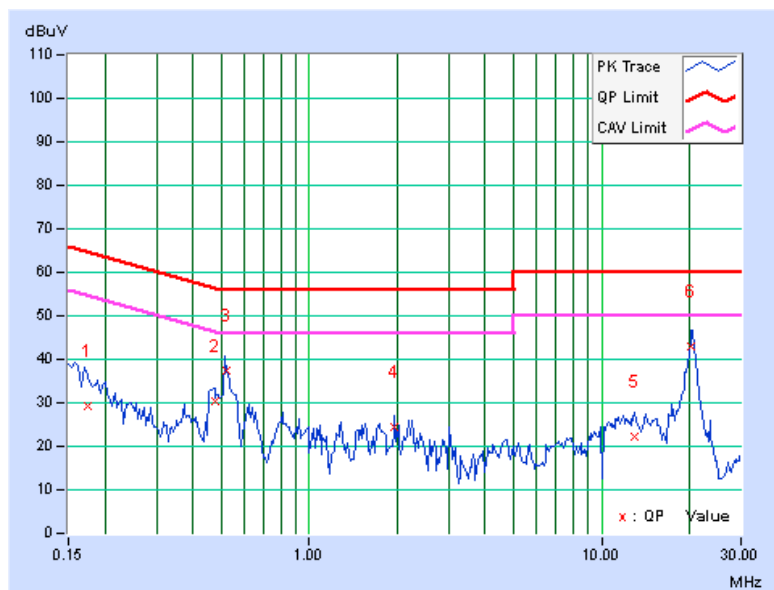

CHANNEL	CH 6 + CH 46	6dB BANDWIDTH	9kHz
PHASE	Line 2		

No	Freq.	Corr. Factor	Reading Value		Emission Level		Limit		Margin	
	[MHz]		[dB (uV)]		[dB (uV)]		[dB (uV)]		(dB)	
			Q.P.	AV.	Q.P.	AV.	Q.P.	AV.	Q.P.	AV.
1	0.15478	0.16	32.64	19.42	32.80	19.58	65.74	55.74	-32.94	-36.16
2	0.51852	0.21	38.04	36.27	38.25	36.48	56.00	46.00	-17.75	-9.52
3	0.81834	0.24	21.08	17.35	21.32	17.59	56.00	46.00	-34.68	-28.41
4	1.95747	0.29	24.17	16.37	24.46	16.66	56.00	46.00	-31.54	-29.34
5	12.87528	0.57	22.21	16.09	22.78	16.66	60.00	50.00	-37.22	-33.34
6	20.30178	0.77	43.24	37.14	44.01	37.91	60.00	50.00	-15.99	-12.09

REMARKS:

1. Q.P. and AV. are abbreviations of quasi-peak and average individually.
2. The emission levels of other frequencies were very low against the limit.
3. Margin value = Emission level - Limit value
4. Correction factor = Insertion loss + Cable loss
5. Emission Level = Correction Factor + Reading Value.

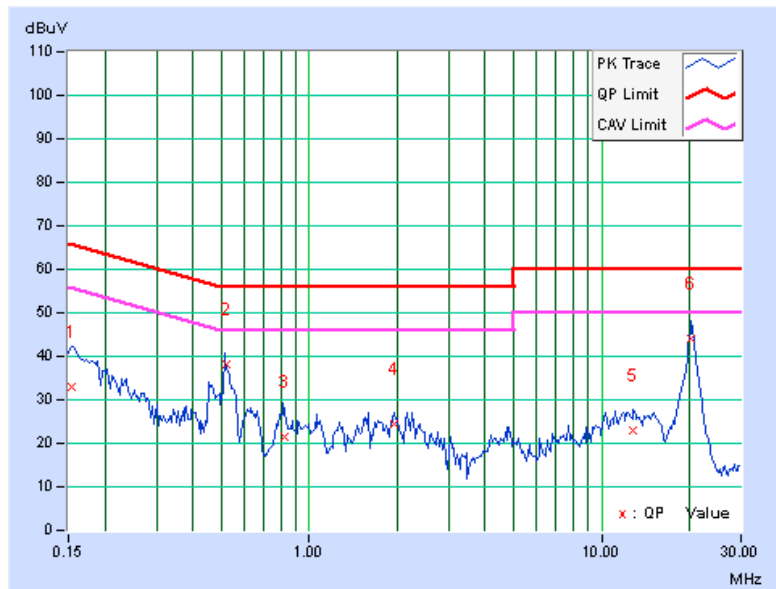

802.11n (20MHz) + 802.11n (20MHz)

CHANNEL	CH 6 + CH 149	6dB BANDWIDTH	9kHz
PHASE	Line 1		

No	Freq. [MHz]	Corr. Factor (dB)	Reading Value		Emission Level		Limit		Margin	
			[dB (uV)]		[dB (uV)]		[dB (uV)]		(dB)	
			Q.P.	AV.	Q.P.	AV.	Q.P.	AV.	Q.P.	AV.
1	0.17427	0.17	30.17	16.82	30.34	16.99	64.75	54.75	-34.41	-37.76
2	0.51934	0.22	37.85	36.18	38.07	36.40	56.00	46.00	-17.93	-9.60
3	0.61524	0.23	23.38	20.01	23.61	20.24	56.00	46.00	-32.39	-25.76
4	1.74706	0.28	22.12	18.23	22.40	18.51	56.00	46.00	-33.60	-27.49
5	11.90778	0.49	22.85	16.78	23.34	17.27	60.00	50.00	-36.66	-32.73
6	20.51262	0.68	42.07	36.27	42.75	36.95	60.00	50.00	-17.25	-13.05

REMARKS:

1. Q.P. and AV. are abbreviations of quasi-peak and average individually.
2. The emission levels of other frequencies were very low against the limit.
3. Margin value = Emission level - Limit value
4. Correction factor = Insertion loss + Cable loss
5. Emission Level = Correction Factor + Reading Value.

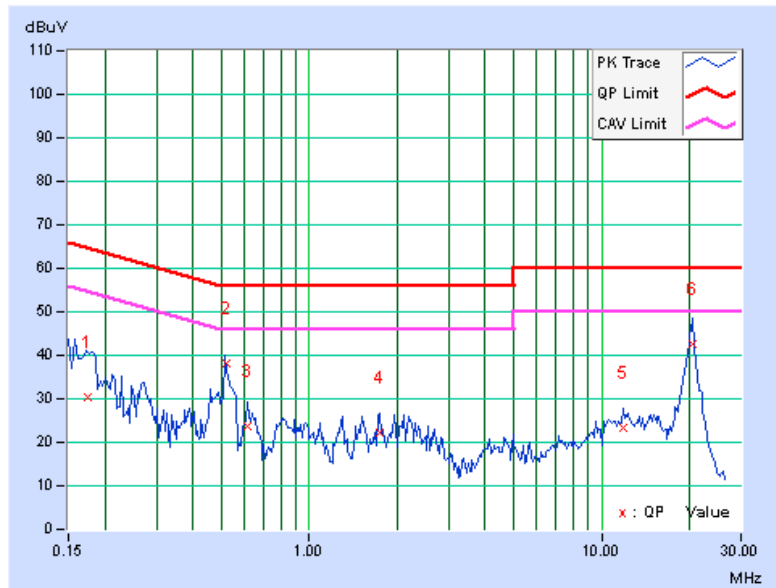

CHANNEL	CH 6 + CH 149	6dB BANDWIDTH	9kHz
PHASE	Line 2		

No	Freq. [MHz]	Corr. Factor (dB)	Reading Value		Emission Level		Limit		Margin	
			[dB (uV)]		[dB (uV)]		[dB (uV)]		(dB)	
			Q.P.	AV.	Q.P.	AV.	Q.P.	AV.	Q.P.	AV.
1	0.15483	0.16	33.54	19.49	33.70	19.65	65.74	55.74	-32.04	-36.09
2	0.51807	0.21	37.28	36.61	37.49	36.82	56.00	46.00	-18.51	-9.18
3	0.81832	0.24	21.07	17.32	21.31	17.56	56.00	46.00	-34.69	-28.44
4	1.95774	0.29	23.59	16.17	23.88	16.46	56.00	46.00	-32.12	-29.54
5	12.87538	0.57	22.03	16.11	22.60	16.68	60.00	50.00	-37.40	-33.32
6	20.30118	0.77	43.26	37.08	44.03	37.85	60.00	50.00	-15.97	-12.15

REMARKS:

1. Q.P. and AV. are abbreviations of quasi-peak and average individually.
2. The emission levels of other frequencies were very low against the limit.
3. Margin value = Emission level - Limit value
4. Correction factor = Insertion loss + Cable loss
5. Emission Level = Correction Factor + Reading Value.

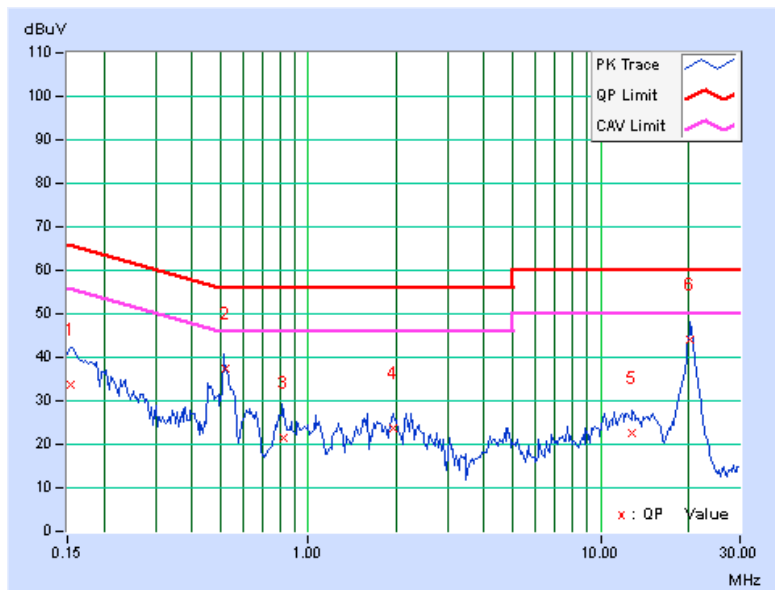

TEST MODE B

802.11b + 802.11a

CHANNEL	CH 6 + CH 40	6dB BANDWIDTH	9kHz
PHASE	Line 1		

No	Freq. [MHz]	Corr. Factor (dB)	Reading Value [dB (uV)]		Emission Level [dB (uV)]		Limit [dB (uV)]		Margin (dB)	
			Q.P.	AV.	Q.P.	AV.	Q.P.	AV.	Q.P.	AV.
			1	0.15391	0.17	52.37	40.75	52.54	40.92	65.79
2	0.16953	0.17	49.39	36.72	49.56	36.89	64.98	54.98	-15.42	-18.09
3	0.20469	0.17	45.31	34.71	45.48	34.88	63.42	53.42	-17.94	-18.54
4	0.50000	0.22	40.53	32.45	40.75	32.67	56.00	46.00	-15.25	-13.33
5	0.83359	0.25	38.62	33.24	38.87	33.49	56.00	46.00	-17.13	-12.51
6	25.33984	0.59	37.97	32.11	38.56	32.70	60.00	50.00	-21.44	-17.30

REMARKS:

1. Q.P. and AV. are abbreviations of quasi-peak and average individually.
2. The emission levels of other frequencies were very low against the limit.
3. Margin value = Emission level - Limit value
4. Correction factor = Insertion loss + Cable loss
5. Emission Level = Correction Factor + Reading Value

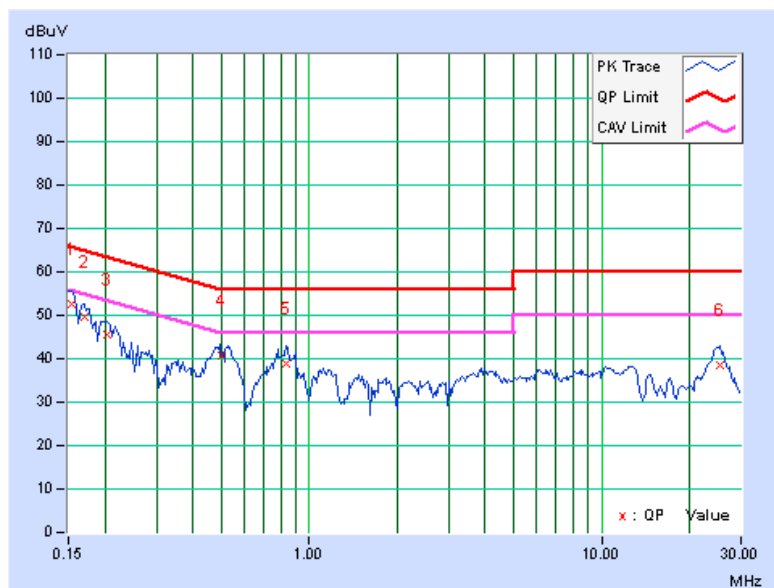



A D T

CHANNEL	CH 6 + CH 40	6dB BANDWIDTH	9kHz
PHASE	Line 2		

No	Freq.	Corr. Factor	Reading Value		Emission Level		Limit		Margin	
	[MHz]		[dB (uV)]		[dB (uV)]		[dB (uV)]		(dB)	
			Q.P.	AV.	Q.P.	AV.	Q.P.	AV.	Q.P.	AV.
1	0.16172	0.18	51.70	39.00	51.88	39.18	65.38	55.38	-13.49	-16.19
2	0.17344	0.18	50.22	38.39	50.40	38.57	64.79	54.79	-14.39	-16.22
3	0.52109	0.25	43.40	37.07	43.65	37.32	56.00	46.00	-12.35	-8.68
4	0.83750	0.24	40.76	34.33	41.00	34.57	56.00	46.00	-15.00	-11.43
5	10.63672	0.50	38.65	34.16	39.15	34.66	60.00	50.00	-20.85	-15.34
6	24.87500	0.69	34.83	29.00	35.52	29.69	60.00	50.00	-24.48	-20.31

REMARKS:

1. Q.P. and AV. are abbreviations of quasi-peak and average individually.
2. The emission levels of other frequencies were very low against the limit.
3. Margin value = Emission level - Limit value
4. Correction factor = Insertion loss + Cable loss
5. Emission Level = Correction Factor + Reading Value

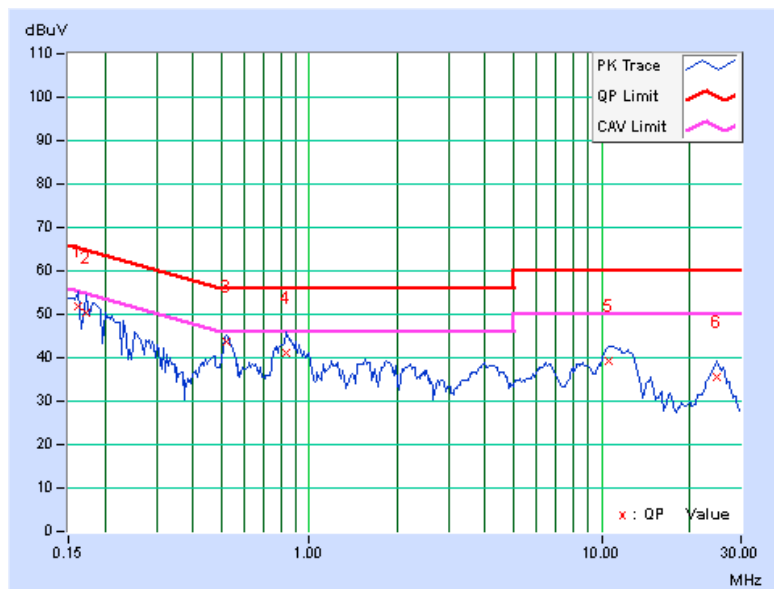

802.11b + 802.11a

CHANNEL	CH 6 + CH 157	6dB BANDWIDTH	9kHz
PHASE	Line 1		

No	Freq.	Corr. Factor (dB)	Reading Value [dB (uV)]		Emission Level [dB (uV)]		Limit [dB (uV)]		Margin (dB)	
	[MHz]		Q.P.	AV.	Q.P.	AV.	Q.P.	AV.	Q.P.	AV.
	1		0.15391	0.17	52.71	41.01	52.88	41.18	65.79	55.79
2	0.18125	0.17	48.25	36.71	48.42	36.88	64.43	54.43	-16.01	-17.55
3	0.50000	0.22	40.50	32.09	40.72	32.31	56.00	46.00	-15.28	-13.69
4	3.76172	0.36	33.55	27.24	33.91	27.60	56.00	46.00	-22.09	-18.40
5	10.58984	0.44	34.10	28.15	34.54	28.59	60.00	50.00	-25.46	-21.41
6	24.82813	0.60	39.02	33.14	39.62	33.74	60.00	50.00	-20.38	-16.26

REMARKS:

1. Q.P. and AV. are abbreviations of quasi-peak and average individually.
2. The emission levels of other frequencies were very low against the limit.
3. Margin value = Emission level - Limit value
4. Correction factor = Insertion loss + Cable loss
5. Emission Level = Correction Factor + Reading Value

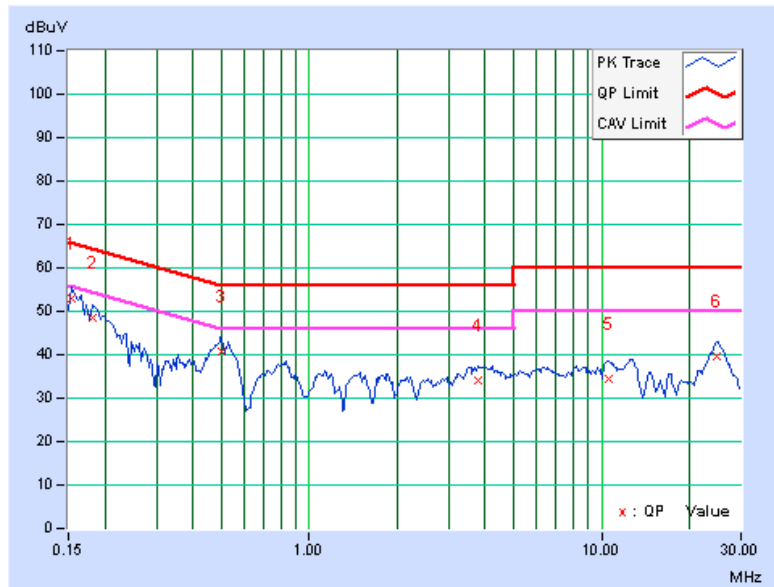

CHANNEL	CH 6 + CH 157	6dB BANDWIDTH	9kHz
PHASE	Line 2		

No	Freq.	Corr. Factor	Reading Value		Emission Level		Limit		Margin	
	[MHz]		[dB (uV)]		[dB (uV)]		[dB (uV)]		(dB)	
			Q.P.	AV.	Q.P.	AV.	Q.P.	AV.	Q.P.	AV.
1	0.15781	0.18	52.31	40.46	52.49	40.64	65.58	55.58	-13.08	-14.93
2	0.51719	0.25	43.25	36.82	43.50	37.07	56.00	46.00	-12.50	-8.93
3	1.51172	0.26	36.72	31.91	36.98	32.17	56.00	46.00	-19.02	-13.83
4	4.01563	0.39	35.20	28.06	35.59	28.45	56.00	46.00	-20.41	-17.55
5	10.89844	0.50	39.12	34.68	39.62	35.18	60.00	50.00	-20.38	-14.82
6	24.84766	0.69	35.04	29.24	35.73	29.93	60.00	50.00	-24.27	-20.07

REMARKS:

1. Q.P. and AV. are abbreviations of quasi-peak and average individually.
2. The emission levels of other frequencies were very low against the limit.
3. Margin value = Emission level - Limit value
4. Correction factor = Insertion loss + Cable loss
5. Emission Level = Correction Factor + Reading Value

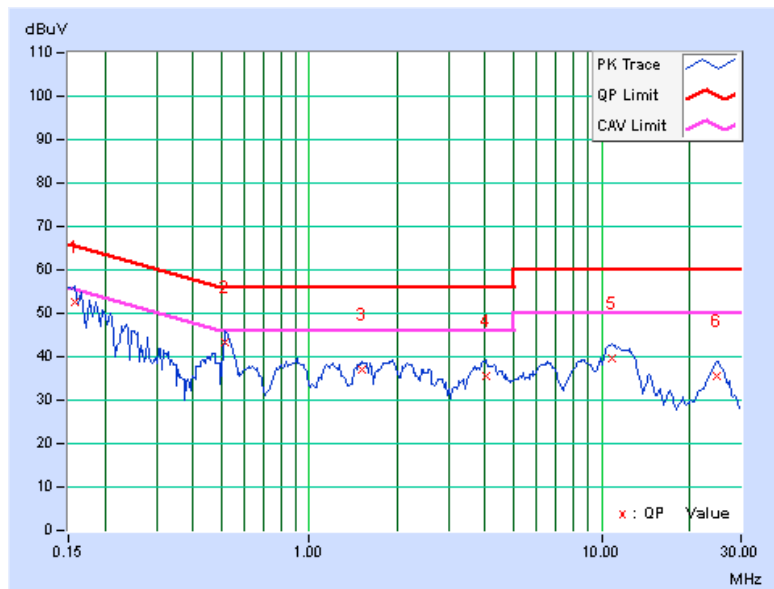

TEST MODE C

802.11b + 802.11a

CHANNEL	CH 11 + CH 36	6dB BANDWIDTH	9kHz
PHASE	Line 1		

No	Freq. [MHz]	Corr. Factor (dB)	Reading Value [dB (uV)]		Emission Level [dB (uV)]		Limit [dB (uV)]		Margin (dB)	
			Q.P.	AV.	Q.P.	AV.	Q.P.	AV.	Q.P.	AV.
			1	0.15781	0.17	51.75	39.83	51.92	40.00	65.58
2	0.49375	0.22	40.64	33.74	40.86	33.96	56.10	46.10	-15.25	-12.15
3	0.77500	0.25	37.37	32.16	37.62	32.41	56.00	46.00	-18.38	-13.59
4	1.51563	0.28	33.34	26.69	33.62	26.97	56.00	46.00	-22.38	-19.03
5	3.82813	0.36	33.71	28.03	34.07	28.39	56.00	46.00	-21.93	-17.61
6	24.78906	0.60	38.82	32.84	39.42	33.44	60.00	50.00	-20.58	-16.56

REMARKS:

1. Q.P. and AV. are abbreviations of quasi-peak and average individually.
2. The emission levels of other frequencies were very low against the limit.
3. Margin value = Emission level - Limit value
4. Correction factor = Insertion loss + Cable loss
5. Emission Level = Correction Factor + Reading Value

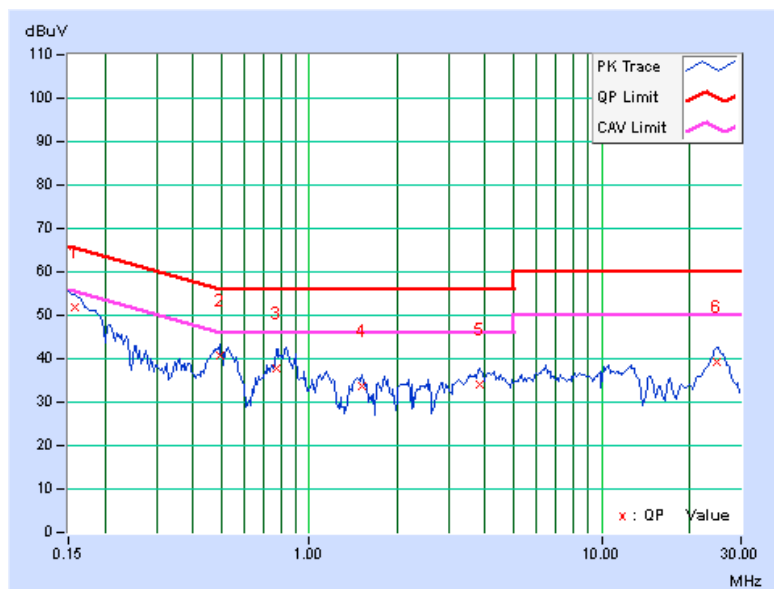

CHANNEL	CH 11 + CH 36	6dB BANDWIDTH	9kHz
PHASE	Line 2		

No	Freq.	Corr. Factor (dB)	Reading Value [dB (uV)]		Emission Level [dB (uV)]		Limit [dB (uV)]		Margin (dB)	
	[MHz]		Q.P.	AV.	Q.P.	AV.	Q.P.	AV.	Q.P.	AV.
	1		0.15781	0.18	52.03	40.22	52.21	40.40	65.58	55.58
2	0.52109	0.25	43.23	36.96	43.48	37.21	56.00	46.00	-12.52	-8.79
3	0.84141	0.24	38.64	33.20	38.88	33.44	56.00	46.00	-17.12	-12.56
4	1.82813	0.27	36.44	31.09	36.71	31.36	56.00	46.00	-19.29	-14.64
5	6.39453	0.43	34.26	29.43	34.69	29.86	60.00	50.00	-25.31	-20.14
6	10.54688	0.49	38.50	33.74	38.99	34.23	60.00	50.00	-21.01	-15.77

REMARKS:

1. Q.P. and AV. are abbreviations of quasi-peak and average individually.
2. The emission levels of other frequencies were very low against the limit.
3. Margin value = Emission level - Limit value
4. Correction factor = Insertion loss + Cable loss
5. Emission Level = Correction Factor + Reading Value

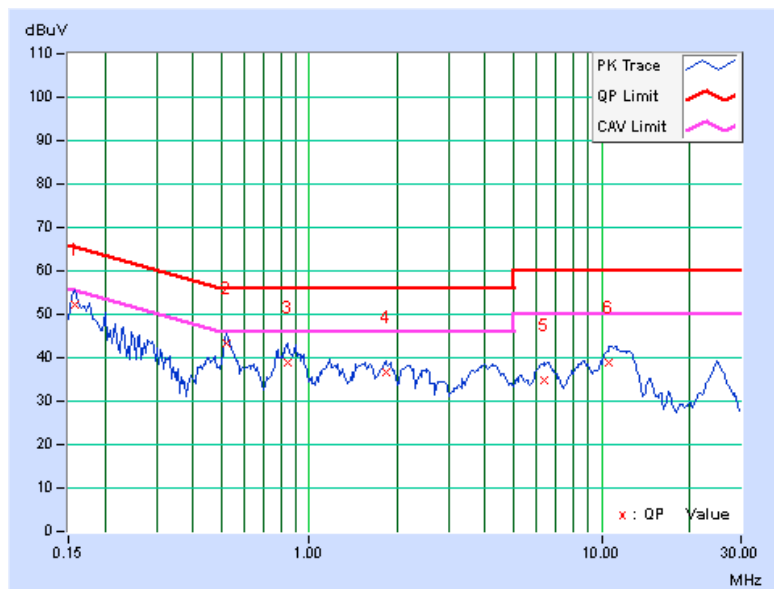



A D T

802.11b + 802.11n (20MHz)

CHANNEL	CH 11 + CH 157	6dB BANDWIDTH	9kHz
PHASE	Line 1		

No	Freq.	Corr. Factor	Reading Value		Emission Level		Limit		Margin	
	[MHz]		[dB (uV)]		[dB (uV)]		[dB (uV)]		(dB)	
			Q.P.	AV.	Q.P.	AV.	Q.P.	AV.	Q.P.	AV.
1	0.15000	0.18	53.13	39.14	53.31	39.32	66.00	56.00	-12.69	-16.68
2	0.49766	0.22	41.23	33.31	41.45	33.53	56.04	46.04	-14.59	-12.51
3	0.83750	0.25	39.19	34.03	39.44	34.28	56.00	46.00	-16.56	-11.72
4	1.46875	0.27	33.48	28.35	33.75	28.62	56.00	46.00	-22.25	-17.38
5	3.91406	0.37	33.54	25.98	33.91	26.35	56.00	46.00	-22.09	-19.65
6	24.82813	0.60	38.66	32.91	39.26	33.51	60.00	50.00	-20.74	-16.49

REMARKS:

1. Q.P. and AV. are abbreviations of quasi-peak and average individually.
2. The emission levels of other frequencies were very low against the limit.
3. Margin value = Emission level - Limit value
4. Correction factor = Insertion loss + Cable loss
5. Emission Level = Correction Factor + Reading Value

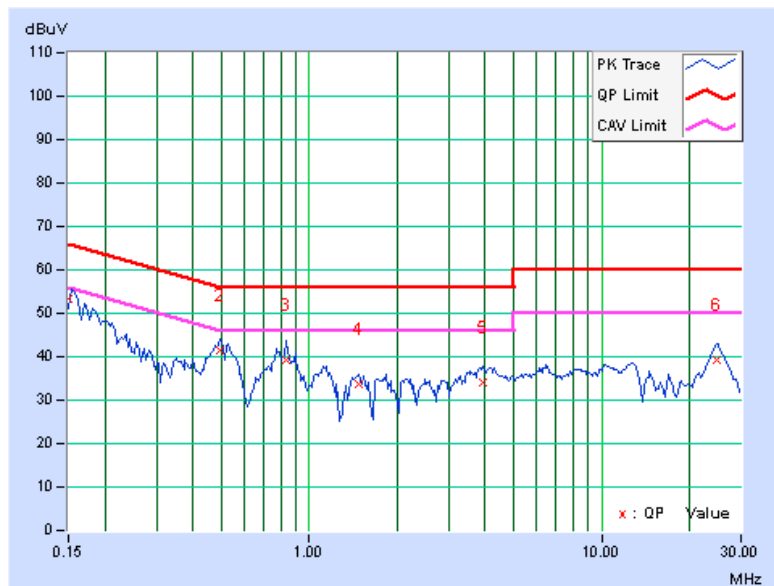



A D T

CHANNEL	CH 11 + CH 157	6dB BANDWIDTH	9kHz
PHASE	Line 2		

No	Freq.	Corr. Factor	Reading Value		Emission Level		Limit		Margin	
	[MHz]		[dB (uV)]		[dB (uV)]		[dB (uV)]		(dB)	
			Q.P.	AV.	Q.P.	AV.	Q.P.	AV.	Q.P.	AV.
1	0.16172	0.18	51.29	38.79	51.47	38.97	65.38	55.38	-13.90	-16.40
2	0.50000	0.25	33.15	25.65	33.40	25.90	56.00	46.00	-22.60	-20.10
3	0.83750	0.24	40.49	35.48	40.73	35.72	56.00	46.00	-15.27	-10.28
4	1.55859	0.26	36.68	30.80	36.94	31.06	56.00	46.00	-19.06	-14.94
5	3.98047	0.39	35.07	28.29	35.46	28.68	56.00	46.00	-20.54	-17.32
6	11.12500	0.51	38.55	34.32	39.06	34.83	60.00	50.00	-20.94	-15.17

REMARKS:

1. Q.P. and AV. are abbreviations of quasi-peak and average individually.
2. The emission levels of other frequencies were very low against the limit.
3. Margin value = Emission level - Limit value
4. Correction factor = Insertion loss + Cable loss
5. Emission Level = Correction Factor + Reading Value

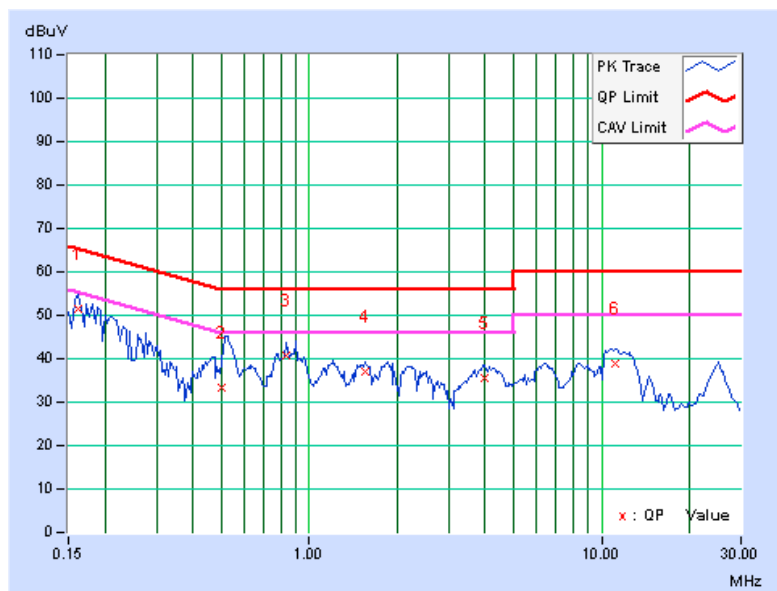



A D T

TEST MODE D

802.11g + 802.11n (20MHz)

CHANNEL	CH 6 + CH 48	6dB BANDWIDTH	9kHz
PHASE	Line 1		

No	Freq. [MHz]	Corr. Factor (dB)	Reading Value [dB (uV)]		Emission Level [dB (uV)]		Limit [dB (uV)]		Margin (dB)	
			Q.P.	AV.	Q.P.	AV.	Q.P.	AV.	Q.P.	AV.
			1	0.15000	0.18	53.47	39.60	53.65	39.78	66.00
2	0.47422	0.22	39.79	34.26	40.01	34.48	56.44	46.44	-16.43	-11.96
3	0.84141	0.25	37.80	32.37	38.05	32.62	56.00	46.00	-17.95	-13.38
4	3.85938	0.36	33.59	27.32	33.95	27.68	56.00	46.00	-22.05	-18.32
5	10.25000	0.44	33.68	27.80	34.12	28.24	60.00	50.00	-25.88	-21.76
6	24.50000	0.60	38.23	32.30	38.83	32.90	60.00	50.00	-21.17	-17.10

REMARKS:

1. Q.P. and AV. are abbreviations of quasi-peak and average individually.
2. The emission levels of other frequencies were very low against the limit.
3. Margin value = Emission level - Limit value
4. Correction factor = Insertion loss + Cable loss
5. Emission Level = Correction Factor + Reading Value

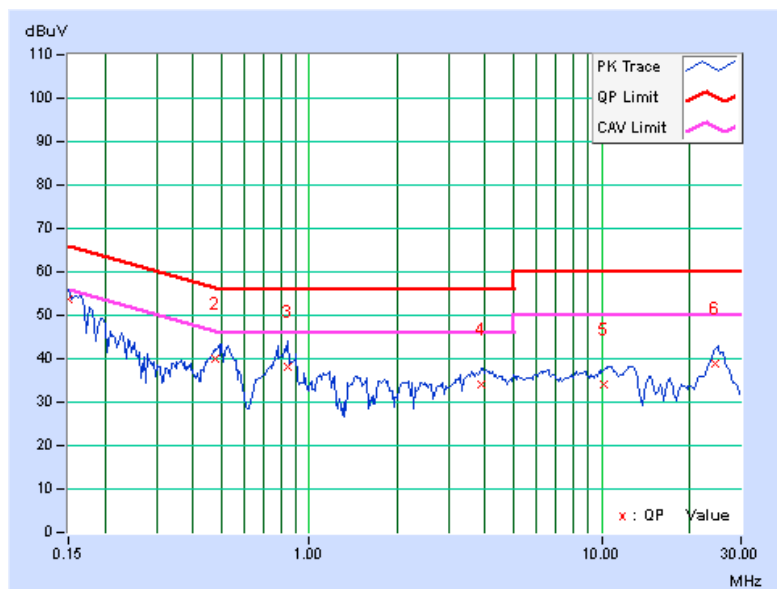



A D T

CHANNEL	CH 6 + CH 48	6dB BANDWIDTH	9kHz
PHASE	Line 2		

No	Freq.	Corr. Factor	Reading Value		Emission Level		Limit		Margin	
	[MHz]		[dB (uV)]		[dB (uV)]		[dB (uV)]		(dB)	
			Q.P.	AV.	Q.P.	AV.	Q.P.	AV.	Q.P.	AV.
1	0.15781	0.18	52.11	40.34	52.29	40.52	65.58	55.58	-13.28	-15.05
2	0.18906	0.18	48.61	37.11	48.79	37.29	64.08	54.08	-15.29	-16.79
3	0.50000	0.25	33.11	25.67	33.36	25.92	56.00	46.00	-22.64	-20.08
4	0.83750	0.24	39.86	34.52	40.10	34.76	56.00	46.00	-15.90	-11.24
5	3.81250	0.38	34.38	28.70	34.76	29.08	56.00	46.00	-21.24	-16.92
6	10.84375	0.50	38.84	34.40	39.34	34.90	60.00	50.00	-20.66	-15.10

REMARKS:

1. Q.P. and AV. are abbreviations of quasi-peak and average individually.
2. The emission levels of other frequencies were very low against the limit.
3. Margin value = Emission level - Limit value
4. Correction factor = Insertion loss + Cable loss
5. Emission Level = Correction Factor + Reading Value

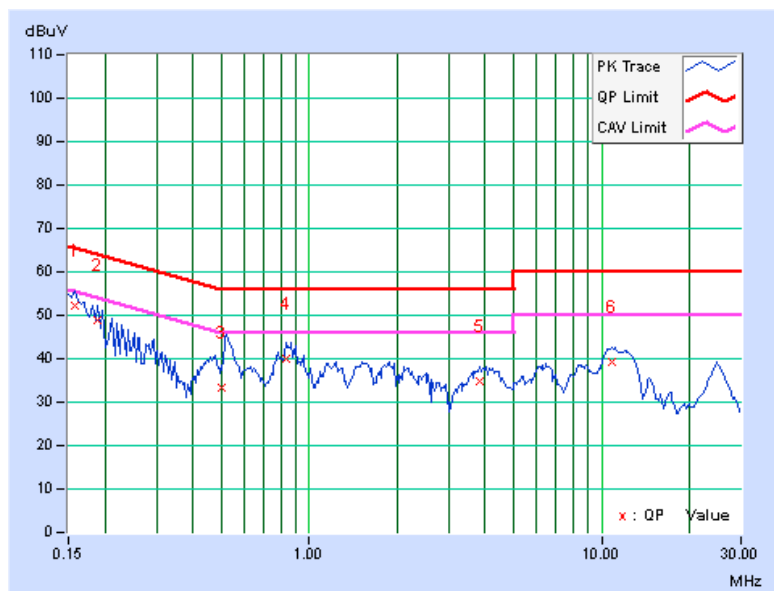



A D T

802.11g + 802.11a

CHANNEL	CH 6 + CH 165	6dB BANDWIDTH	9kHz
PHASE	Line 1		

No	Freq.	Corr. Factor (dB)	Reading Value [dB (uV)]		Emission Level [dB (uV)]		Limit [dB (uV)]		Margin (dB)	
	[MHz]		Q.P.	AV.	Q.P.	AV.	Q.P.	AV.	Q.P.	AV.
	1		0.15000	0.18	53.39	39.62	53.57	39.80	66.00	56.00
2	0.49375	0.22	40.72	33.56	40.94	33.78	56.10	46.10	-15.17	-12.33
3	0.81016	0.25	36.43	31.16	36.68	31.41	56.00	46.00	-19.32	-14.59
4	3.95703	0.37	33.63	25.58	34.00	25.95	56.00	46.00	-22.00	-20.05
5	12.57031	0.48	34.91	31.32	35.39	31.80	60.00	50.00	-24.61	-18.20
6	24.71094	0.60	38.68	32.74	39.28	33.34	60.00	50.00	-20.72	-16.66

REMARKS:

1. Q.P. and AV. are abbreviations of quasi-peak and average individually.
2. The emission levels of other frequencies were very low against the limit.
3. Margin value = Emission level - Limit value
4. Correction factor = Insertion loss + Cable loss
5. Emission Level = Correction Factor + Reading Value

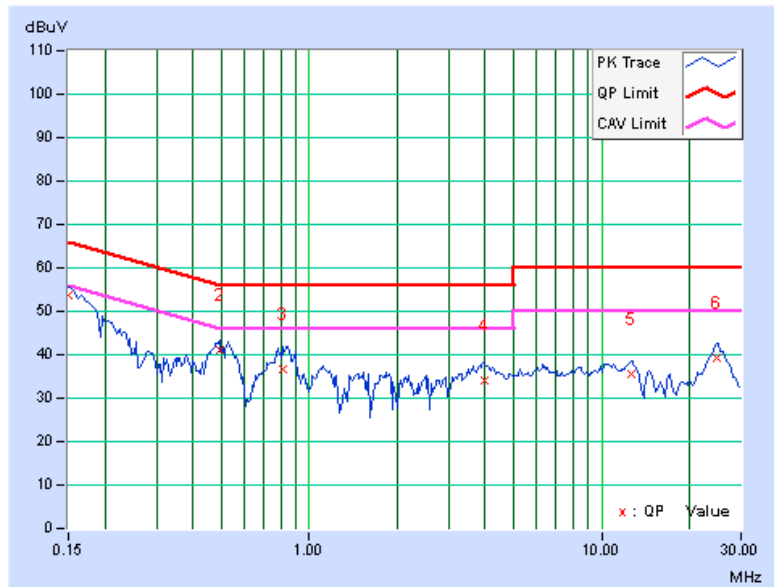

CHANNEL	CH 6 + CH 165	6dB BANDWIDTH	9kHz
PHASE	Line 2		

No	Freq.	Corr. Factor	Reading Value		Emission Level		Limit		Margin	
	[MHz]		[dB (uV)]		[dB (uV)]		[dB (uV)]		(dB)	
			Q.P.	AV.	Q.P.	AV.	Q.P.	AV.	Q.P.	AV.
1	0.15781	0.18	52.07	40.26	52.25	40.44	65.58	55.58	-13.32	-15.13
2	0.19297	0.18	48.28	37.22	48.46	37.40	63.91	53.91	-15.45	-16.51
3	0.52109	0.25	43.23	36.98	43.48	37.23	56.00	46.00	-12.52	-8.77
4	0.83750	0.24	39.81	34.48	40.05	34.72	56.00	46.00	-15.95	-11.28
5	3.93359	0.39	35.16	28.81	35.55	29.20	56.00	46.00	-20.45	-16.80
6	10.85547	0.50	38.84	34.40	39.34	34.90	60.00	50.00	-20.66	-15.10

REMARKS:

1. Q.P. and AV. are abbreviations of quasi-peak and average individually.
2. The emission levels of other frequencies were very low against the limit.
3. Margin value = Emission level - Limit value
4. Correction factor = Insertion loss + Cable loss
5. Emission Level = Correction Factor + Reading Value

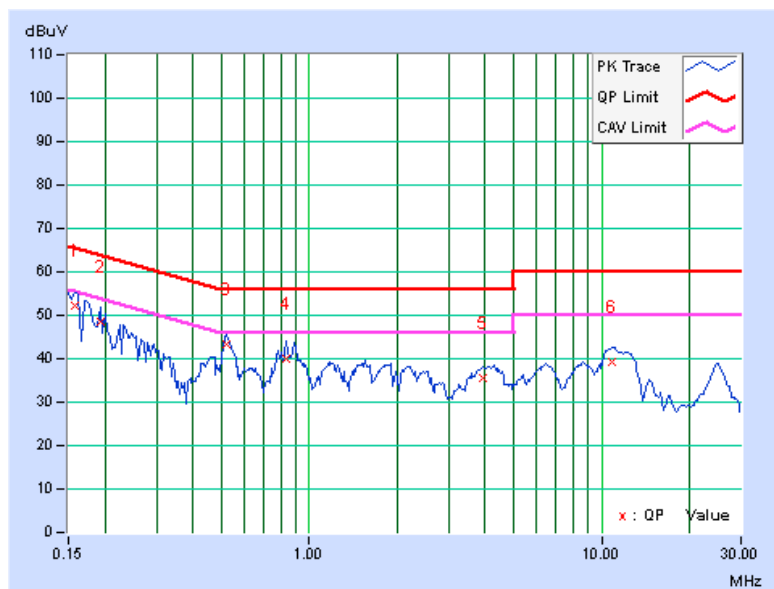



A D T

TEST MODE E

802.11g + 802.11n (20MHz)

CHANNEL	CH 6 + CH 40	6dB BANDWIDTH	9kHz
PHASE	Line 1		

No	Freq. [MHz]	Corr. Factor (dB)	Reading Value [dB (uV)]		Emission Level [dB (uV)]		Limit [dB (uV)]		Margin (dB)	
			Q.P.	AV.	Q.P.	AV.	Q.P.	AV.	Q.P.	AV.
			1	0.15000	0.18	53.31	39.50	53.49	39.68	66.00
2	0.48984	0.22	40.14	33.77	40.36	33.99	56.17	46.17	-15.81	-12.18
3	0.77891	0.25	38.34	33.15	38.59	33.40	56.00	46.00	-17.41	-12.60
4	3.91016	0.37	33.97	27.09	34.34	27.46	56.00	46.00	-21.66	-18.54
5	12.68750	0.49	34.92	31.27	35.41	31.76	60.00	50.00	-24.59	-18.24
6	24.48828	0.60	38.25	32.26	38.85	32.86	60.00	50.00	-21.15	-17.14

REMARKS:

1. Q.P. and AV. are abbreviations of quasi-peak and average individually.
2. The emission levels of other frequencies were very low against the limit.
3. Margin value = Emission level - Limit value
4. Correction factor = Insertion loss + Cable loss
5. Emission Level = Correction Factor + Reading Value

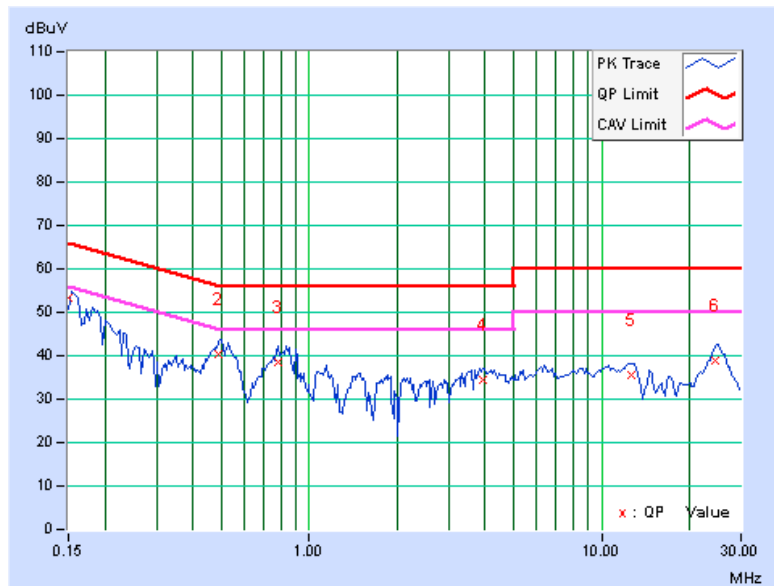

CHANNEL	CH 6 + CH 40	6dB BANDWIDTH	9kHz
PHASE	Line 2		

No	Freq.	Corr. Factor	Reading Value		Emission Level		Limit		Margin	
	[MHz]		[dB (uV)]		[dB (uV)]		[dB (uV)]		(dB)	
			Q.P.	AV.	Q.P.	AV.	Q.P.	AV.	Q.P.	AV.
1	0.16172	0.18	51.23	38.77	51.41	38.95	65.38	55.38	-13.96	-16.42
2	0.52500	0.25	43.03	36.88	43.28	37.13	56.00	46.00	-12.72	-8.87
3	0.86094	0.23	36.85	31.31	37.08	31.54	56.00	46.00	-18.92	-14.46
4	3.98828	0.39	34.58	27.87	34.97	28.26	56.00	46.00	-21.03	-17.74
5	10.61719	0.50	38.58	33.96	39.08	34.46	60.00	50.00	-20.92	-15.54
6	24.94531	0.69	34.72	29.00	35.41	29.69	60.00	50.00	-24.59	-20.31

REMARKS:

1. Q.P. and AV. are abbreviations of quasi-peak and average individually.
2. The emission levels of other frequencies were very low against the limit.
3. Margin value = Emission level - Limit value
4. Correction factor = Insertion loss + Cable loss
5. Emission Level = Correction Factor + Reading Value

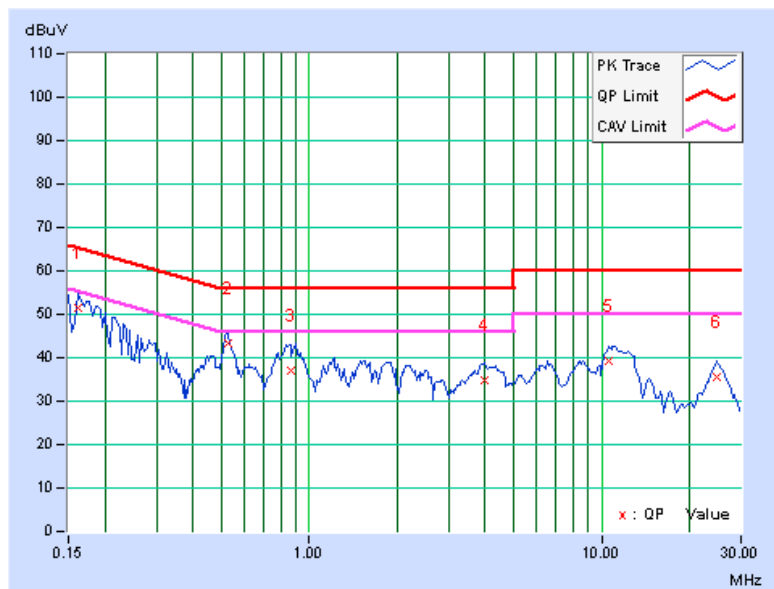

802.11g + 802.11a

CHANNEL	CH 6 + CH 157	6dB BANDWIDTH	9kHz
PHASE	Line 1		

No	Freq. [MHz]	Corr. Factor (dB)	Reading Value [dB (uV)]		Emission Level [dB (uV)]		Limit [dB (uV)]		Margin (dB)	
			Q.P.	AV.	Q.P.	AV.	Q.P.	AV.	Q.P.	AV.
			1	0.15391	0.17	52.35	40.75	52.52	40.92	65.79
2	0.49766	0.22	40.98	33.03	41.20	33.25	56.04	46.04	-14.84	-12.79
3	0.83750	0.25	39.67	34.42	39.92	34.67	56.00	46.00	-16.08	-11.33
4	3.65625	0.35	32.81	24.18	33.16	24.53	56.00	46.00	-22.84	-21.47
5	10.71094	0.44	33.85	28.13	34.29	28.57	60.00	50.00	-25.71	-21.43
6	24.81641	0.60	38.77	32.93	39.37	33.53	60.00	50.00	-20.63	-16.47

REMARKS:

1. Q.P. and AV. are abbreviations of quasi-peak and average individually.
2. The emission levels of other frequencies were very low against the limit.
3. Margin value = Emission level - Limit value
4. Correction factor = Insertion loss + Cable loss
5. Emission Level = Correction Factor + Reading Value

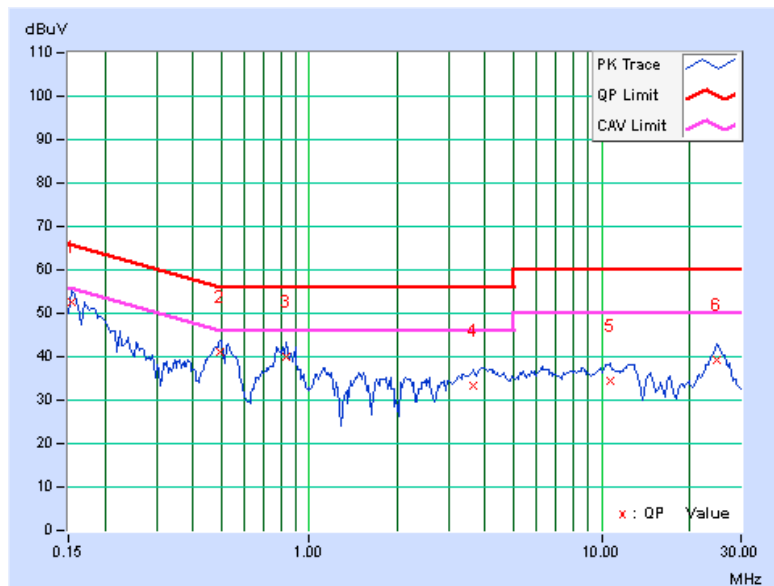



A D T

CHANNEL	CH 6 + CH 157	6dB BANDWIDTH	9kHz
PHASE	Line 2		

No	Freq.	Corr. Factor	Reading Value		Emission Level		Limit		Margin	
	[MHz]		[dB (uV)]		[dB (uV)]		[dB (uV)]		(dB)	
			Q.P.	AV.	Q.P.	AV.	Q.P.	AV.	Q.P.	AV.
1	0.15391	0.18	52.67	41.09	52.85	41.27	65.79	55.79	-12.93	-14.51
2	0.18906	0.18	48.47	37.05	48.65	37.23	64.08	54.08	-15.43	-16.85
3	0.51328	0.25	42.32	35.72	42.57	35.97	56.00	46.00	-13.43	-10.03
4	0.83750	0.24	40.12	34.85	40.36	35.09	56.00	46.00	-15.64	-10.91
5	10.92969	0.50	38.76	34.40	39.26	34.90	60.00	50.00	-20.74	-15.10
6	25.00000	0.69	34.80	28.92	35.49	29.61	60.00	50.00	-24.51	-20.39

REMARKS:

1. Q.P. and AV. are abbreviations of quasi-peak and average individually.
2. The emission levels of other frequencies were very low against the limit.
3. Margin value = Emission level - Limit value
4. Correction factor = Insertion loss + Cable loss
5. Emission Level = Correction Factor + Reading Value

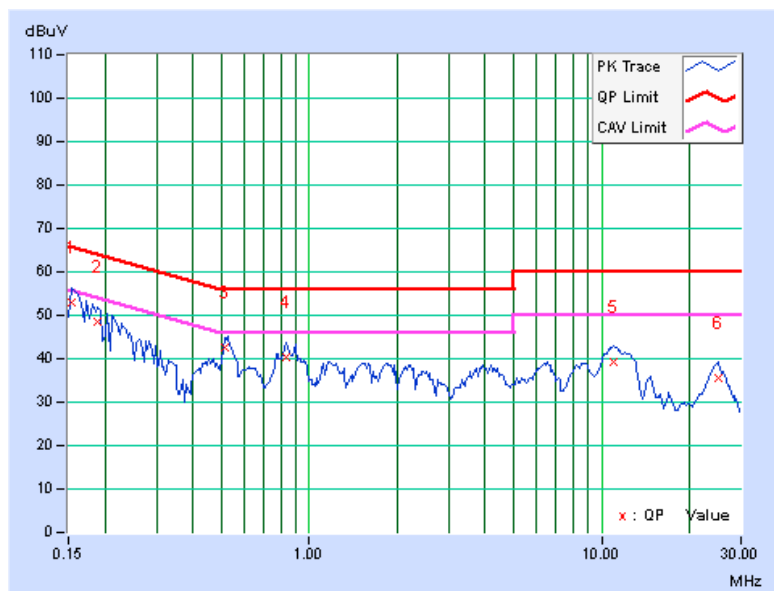



A D T

5. PHOTOGRAPHS OF THE TEST CONFIGURATION

Please refer to the attached file (Test Setup Photo).



A D T

6. INFORMATION ON THE TESTING LABORATORIES

We, Bureau Veritas Consumer Products Services (H.K.) Ltd., Taoyuan Branch, were founded in 1988 to provide our best service in EMC, Radio, Telecom and Safety consultation. Our laboratories are accredited and approved according to ISO/IEC 17025.

If you have any comments, please feel free to contact us at the following:

Linko EMC/RF Lab

Tel: 886-2-26052180

Fax: 886-2-26051924

Hsin Chu EMC/RF Lab

Tel: 886-3-5935343

Fax: 886-3-5935342

Hwa Ya EMC/RF/Safety/Telecom Lab

Tel: 886-3-3183232

Fax: 886-3-3270892

Email: service.adt@tw.bureauveritas.com

Web Site: www.bureauveritas-adt.com

The address and road map of all our labs can be found in our web site also.



A D T

7. APPENDIX A - MODIFICATIONS RECORDERS FOR ENGINEERING CHANGES TO THE EUT BY THE LAB

No modifications were made to the EUT by the lab during the test.

---END---