

FCC Test Report

FCC ID : QXO-AP310
Equipment : Wireless Access Point
Brand Name :  or Extreme Networks
Model Name : AP310i, AP310e
Applicant : Extreme Networks, Inc.
6480 Via Del Oro, San Jose, CA 95119, United States
Manufacturer : Extreme Networks, Inc.
6480 Via Del Oro, San Jose, CA 95119, United States
Standard : 47 CFR FCC Part 15.407

The product was received on Nov. 29, 2019, and testing was started from Dec. 26, 2019 and completed on Jan. 30, 2020. We, SPORTON INTERNATIONAL INC. EMC & Wireless Communications Laboratory, would like to declare that the tested sample has been evaluated in accordance with the procedures given in ANSI C63.10-2013 and shown compliance with the applicable technical standards.

The report must not be used by the client to claim product certification, approval, or endorsement by TAF or any agency of government.

The test results in this report apply exclusively to the tested model / sample. Without written approval of SPORTON INTERNATIONAL INC. EMC & Wireless Communications Laboratory, the test report shall not be reproduced except in full.



Approved by: Allen Lin

SPORTON INTERNATIONAL INC. EMC & Wireless Communications Laboratory

No. 52, Huaya 1st Rd., Guishan Dist., Taoyuan City, Taiwan (R.O.C.)



Table of Contents

HISTORY OF THIS TEST REPORT3

SUMMARY OF TEST RESULT4

1 GENERAL DESCRIPTION5

1.1 Information.....5

1.2 Testing Applied Standards13

1.3 Testing Location Information13

1.4 Measurement Uncertainty13

2 TEST CONFIGURATION OF EUT.....14

2.1 Test Condition14

2.2 Test Channel Mode14

2.3 The Worst Case Measurement Configuration.....50

2.4 Support Equipment.....52

2.5 Test Setup Diagram53

3 TRANSMITTER TEST RESULT56

3.1 Emission Bandwidth.....56

3.2 Maximum Conducted Output Power57

3.3 Peak Power Spectral Density.....59

3.4 Unwanted Emissions.....61

4 TEST EQUIPMENT AND CALIBRATION DATA.....66

APPENDIX A. TEST RESULTS OF EMISSION BANDWIDTH

APPENDIX B. TEST RESULTS OF MAXIMUM CONDUCTED OUTPUT POWER AND

APPENDIX C. TEST RESULTS OF PEAK POWER SPECTRAL DENSITY

APPENDIX D. TEST RESULTS OF UNWANTED EMISSIONS

APPENDIX E. TEST PHOTOS

PHOTOGRAPHS OF EUT V01



Summary of Test Result

Report Clause	Ref. Std. Clause	Test Items	Result (PASS/FAIL)	Remark
1.1.2	15.203	Antenna Requirement	PASS	-
-	15.207	AC Power-line Conducted Emissions	Not Performed	-
3.1	15.407(a)	Emission Bandwidth	PASS	-
3.2	15.407(a)	Maximum Conducted Output Power	PASS	-
3.3	15.407(a)	Peak Power Spectral Density	PASS	-
3.4	15.407(b)	Unwanted Emissions	PASS	-

Declaration of Conformity:
The test results with all measurement uncertainty excluded are presented in accordance with the regulation limits or requirements declared by manufacturers.
Comments and explanations:
None

Reviewed by: Sam Tsai

Report Producer: Debby Hung



1 General Description

1.1 Information

1.1.1 RF General Information

Frequency Range (MHz)	IEEE Std. 802.11	Ch. Frequency (MHz)	Channel Number
5250-5350	a, n (HT20), ac (VHT20), ax(HEW 20)	5260-5320	52-64 [4]
5470-5725		5500-5700	100-140 [11]
Straddle 5720		5720	144 [1]
5250-5350	n (HT40), ac (VHT40), ax(HEW 40)	5270-5310	54-62 [2]
5470-5725		5510-5670	102-134 [5]
Straddle 5710		5710	142 [1]
5250-5350	ac (VHT80), ax(HEW 80)	5290	58 [1]
5470-5725		5530-5610	106-122 [2]
Straddle 5690		5690	138 [1]

Non-Beamforming

Band	Mode	BWch (MHz)	Nant
5.25-5.35GHz	802.11a	20	1TX
5.47-5.725GHz	802.11a	20	1TX
5.725-5.85GHz	802.11a	20	1TX
5.25-5.35GHz	802.11ac VHT20	20	1TX
5.47-5.725GHz	802.11ac VHT20	20	1TX
5.725-5.85GHz	802.11ac VHT20	20	1TX
5.25-5.35GHz	802.11ac VHT40	40	1TX
5.47-5.725GHz	802.11ac VHT40	40	1TX
5.725-5.85GHz	802.11ac VHT40	40	1TX
5.25-5.35GHz	802.11ac VHT80	80	1TX
5.47-5.725GHz	802.11ac VHT80	80	1TX
5.725-5.85GHz	802.11ac VHT80	80	1TX
5.25-5.35GHz	802.11ax HEW20	20	1TX
5.47-5.725GHz	802.11ax HEW20	20	1TX
5.725-5.85GHz	802.11ax HEW20	20	1TX
5.25-5.35GHz	802.11ax HEW40	40	1TX
5.47-5.725GHz	802.11ax HEW40	40	1TX
5.725-5.85GHz	802.11ax HEW40	40	1TX



Band	Mode	BWch (MHz)	Nant
5.25-5.35GHz	802.11ax HEW80	80	1TX
5.47-5.725GHz	802.11ax HEW80	80	1TX
5.725-5.85GHz	802.11ax HEW80	80	1TX
5.25-5.35GHz	802.11a	20	2TX
5.47-5.725GHz	802.11a	20	2TX
5.725-5.85GHz	802.11a	20	2TX
5.25-5.35GHz	802.11ac VHT20	20	2TX
5.47-5.725GHz	802.11ac VHT20	20	2TX
5.725-5.85GHz	802.11ac VHT20	20	2TX
5.25-5.35GHz	802.11ac VHT40	40	2TX
5.47-5.725GHz	802.11ac VHT40	40	2TX
5.725-5.85GHz	802.11ac VHT40	40	2TX
5.25-5.35GHz	802.11ac VHT80	80	2TX
5.47-5.725GHz	802.11ac VHT80	80	2TX
5.725-5.85GHz	802.11ac VHT80	80	2TX
5.25-5.35GHz	802.11ax HEW20	20	2TX
5.47-5.725GHz	802.11ax HEW20	20	2TX
5.725-5.85GHz	802.11ax HEW20	20	2TX
5.25-5.35GHz	802.11ax HEW40	40	2TX
5.47-5.725GHz	802.11ax HEW40	40	2TX
5.725-5.85GHz	802.11ax HEW40	40	2TX
5.25-5.35GHz	802.11ax HEW80	80	2TX
5.47-5.725GHz	802.11ax HEW80	80	2TX
5.725-5.85GHz	802.11ax HEW80	80	2TX



Beamforming

Band	Mode	BWch (MHz)	Nant
5.25-5.35GHz	802.11ac VHT20-BF	20	2TX
5.47-5.725GHz	802.11ac VHT20-BF	20	2TX
5.725-5.85GHz	802.11ac VHT20-BF	20	2TX
5.25-5.35GHz	802.11ac VHT40-BF	40	2TX
5.47-5.725GHz	802.11ac VHT40-BF	40	2TX
5.725-5.85GHz	802.11ac VHT40-BF	40	2TX
5.25-5.35GHz	802.11ac VHT80-BF	80	2TX
5.47-5.725GHz	802.11ac VHT80-BF	80	2TX
5.725-5.85GHz	802.11ac VHT80-BF	80	2TX
5.25-5.35GHz	802.11ax HEW20-BF	20	2TX
5.47-5.725GHz	802.11ax HEW20-BF	20	2TX
5.725-5.85GHz	802.11ax HEW20-BF	20	2TX
5.25-5.35GHz	802.11ax HEW40-BF	40	2TX
5.47-5.725GHz	802.11ax HEW40-BF	40	2TX
5.725-5.85GHz	802.11ax HEW40-BF	40	2TX
5.25-5.35GHz	802.11ax HEW80-BF	80	2TX
5.47-5.725GHz	802.11ax HEW80-BF	80	2TX
5.725-5.85GHz	802.11ax HEW80-BF	80	2TX

Note:

- ♦ 11a, HT20 and HT40 use a combination of OFDM-BPSK, QPSK, 16QAM, 64QAM modulation.
- ♦ VHT20, VHT40, VHT80 use a combination of OFDM-BPSK, QPSK, 16QAM, 64QAM, 256QAM modulation.
- ♦ HEW20, HEW40, HEW80 use a combination of OFDMA-BPSK, QPSK, 16QAM, 64QAM, 256QAM, 1024QAM modulation.
- ♦ BWch is the nominal channel bandwidth.
- ♦ The resource unit of HEW 20, HEW 40, HEW 80 only support full loading.

1.1.2 Antenna Information
(AP310i) Internal Antenna

Ant.	Brand	Model Number (P/N)	Antenna Type	Connector	Antenna Gain (dBi)			Remark
					2.4GHz	5GHz	BLE/Thread	
1	SENAO	5718A0485300	PIFA	IPEX	4.5	5.17	-	Radio 1
2	SENAO	5718A0487300	PIFA	IPEX	4.53	5.07	-	Radio 1
3	SENAO	5718A0486300	PIFA	IPEX	-	4.81	-	Radio 2
4	SENAO	5718A0488300	PIFA	IPEX	-	4.75	-	Radio 2
5	SENAO	5718A0489300	PIFA	IPEX	-	-	4.74	Radio 3

(AP310e) External Antenna

Group	Brand	Model Number (P/N)	Antenna Type	Connector	Antenna Gain (dBi)		
					2.4GHz	5GHz	BLE/Thread
1	Extreme	ML-2452-APA2-01	Omni	Reverse SMA	3.17	4.85	-
2	Extreme	ML-2452-HPA5-036	Omni	Reverse SMA	3.9	5.7	-
3	Extreme	ML-2452-HPAG4A6-01	Omni	N-type	4	7.3	-
4	Extreme	ML-2452-PTA4M4-036	Omni	Reverse SMA	5	6.6	-
5	Extreme	ML-2452-HPAG5A8-01	Omni	N-type	5	8	-
6	Extreme	30724 WS-AO-DQ04360N	Omni	N-type	5.5	6	-
7	Extreme	AI-DQ04360S	Omni	Reverse SMA	5.5	6	-
8	Extreme	ML-2452-PNA5-01R	Panel	N-type	4.5	5	-
9	Extreme	ML-2452-SEC6M4-036, WS-AI-DQ05120 (30702)	Panel	Reverse SMA	6.92	7.23	-
10	Extreme	30705 WS-AI-DE07025	Panel	Reverse SMA	7.5	6.5	-
11	Extreme	ML-2452-PNA7-01R	Panel	N-type	7.8	10.7	7.8
12	Extreme	30707 WS-AI-DE10055	Panel	Reverse SMA	10.5	7.5	-
13	Extreme	ML-2452-APA2-02	Omni	Reverse SMA	3.17	4.85	-
14	Extreme	ML-2499-HPA8-01	Dipole	N-type	-	-	8

Note 1: Group 5, 11,12 were measured during the test for WLAN 2.4G Mode.

Note 2: Group 11,14 were measured during the test for Bluetooth/Thread Mode.

Note 3: Group 5,11 were measured during the test for WLAN 5G Mode.



For 2.4GHz function:

For IEEE 802.11 b/g/n/ax mode (1TX/1RX)
Only port 1 can be used as transmitting/receiving antenna.
For IEEE 802.11 b/g/n/ax mode (2TX/2RX)
Port 1 and port 2 could transmit/receive simultaneously.

For BT function:

For IEEE 802.15.1 Bluetooth mode (1TX/1RX)
Only port 1 can be used as transmitting/receiving antenna.

For Thread function:

For IEEE 802.15.4 Thread mode (1TX/1RX)
Only port 1 can be used as transmitting/receiving antenna.

For 5GHz function:

For IEEE 802.11 a/n/ac/ax mode (1TX/1RX)
Only port 1 can be used as transmitting/receiving antenna.
For IEEE 802.11 a/n/ac/ax mode (2TX/2RX)
Port 1 and port 2 could transmit/receive simultaneously.

1.1.3 EUT Information

Operational Condition				
EUT Power Type	From PoE			
EUT Function	<input type="checkbox"/>	Outdoor AP	<input checked="" type="checkbox"/>	Indoor AP
	<input type="checkbox"/>	Fixed P2P AP	<input type="checkbox"/>	Outdoor/Indoor Client
Beamforming Function	<input checked="" type="checkbox"/>	With beamforming	<input type="checkbox"/>	Without beamforming
Type of EUT				
<input checked="" type="checkbox"/>	Stand-alone			
<input type="checkbox"/>	Combined (EUT where the radio part is fully integrated within another device)			
	Combined Equipment - Brand Name / Model No.: ...			
<input type="checkbox"/>	Plug-in radio (EUT intended for a variety of host systems)			
	Host System - Brand Name / Model No.: ...			
<input type="checkbox"/>	Other:			



1.1.4 Table for Multiple Listing

Sample Number	Model Name	Description
1	AP310i	The "i" in AP310i indicates that it comes with internal antennas and the "e" in AP310e indicates that the access point comes with external antenna connectors.
2	AP310e	

1.1.5 Table for Permissive Change

This product is an extension of original one reported under Sporton project number: FR992608AN

Below is the table for the change of the product with respect to the original one.

Modifications	Performance Checking
U-NII-2A and UNII-2C were added.	All

1.1.6 Mode Test Duty Cycle

Non-Beamforming

Sample 1_Radio 1_1T1S

Mode	DC	DCF(dB)	T(s)	VBW(Hz) ≥ 1/T
802.11a_Nss1,(6Mbps)_1TX	0.951	0.22	2.066m	1k
802.11ac VHT20_Nss1,(MCS0)_1TX	0.986	0.06	n/a (DC>=0.98)	n/a (DC>=0.98)
802.11ac VHT40_Nss1,(MCS0)_1TX	0.972	0.12	954.375u	3k
802.11ac VHT80_Nss1,(MCS0)_1TX	0.944	0.25	463.125u	3k
802.11ax HEW20_Nss1,(MCS0)_1TX	0.981	0.08	n/a (DC>=0.98)	n/a (DC>=0.98)
802.11ax HEW40_Nss1,(MCS0)_1TX	0.964	0.16	774.375u	3k
802.11ax HEW80_Nss1,(MCS0)_1TX	0.93	0.32	403.125u	3k

Sample 1_Radio 1_2T2S

Mode	DC	DCF(dB)	T(s)	VBW(Hz) ≥ 1/T
802.11a_Nss1,(6Mbps)_2TX	0.954	0.2	2.064m	1k
802.11ac VHT20_Nss2,(MCS0)_2TX	0.971	0.13	988.438u	3k
802.11ac VHT40_Nss2,(MCS0)_2TX	0.948	0.23	500.625u	3k
802.11ac VHT80_Nss2,(MCS0)_2TX	0.899	0.46	256.563u	10k
802.11ax HEW20_Nss2,(MCS0)_2TX	0.963	0.16	779.688u	3k
802.11ax HEW40_Nss2,(MCS0)_2TX	0.929	0.32	421.875u	3k
802.11ax HEW80_Nss2,(MCS0)_2TX	0.887	0.52	239.688u	10k



Sample 2_Radio 1_1T1S

Mode	DC	DCF(dB)	T(s)	VBW(Hz) $\geq 1/T$
802.11a_Nss1,(6Mbps)_1TX	0.951	0.22	2.066m	1k
802.11ac VHT20_Nss1,(MCS0)_1TX	0.986	0.06	n/a (DC \geq 0.98)	n/a (DC \geq 0.98)
802.11ac VHT40_Nss1,(MCS0)_1TX	0.971	0.13	954.688u	3k
802.11ac VHT80_Nss1,(MCS0)_1TX	0.944	0.25	462.5u	3k
802.11ax HEW20_Nss1,(MCS0)_1TX	0.98	0.09	n/a (DC \geq 0.98)	n/a (DC \geq 0.98)
802.11ax HEW40_Nss1,(MCS0)_1TX	0.963	0.16	775u	3k
802.11ax HEW80_Nss1,(MCS0)_1TX	0.929	0.32	403.125u	3k

Sample 2_Radio 1_2T2S

Mode	DC	DCF(dB)	T(s)	VBW(Hz) $\geq 1/T$
802.11a_Nss1,(6Mbps)_2TX	0.95	0.22	2.066m	1k
802.11ac VHT20_Nss2,(MCS0)_2TX	0.973	0.12	990.625u	3k
802.11ac VHT40_Nss2,(MCS0)_2TX	0.947	0.24	501.563u	3k
802.11ac VHT80_Nss2,(MCS0)_2TX	0.903	0.44	257.813u	10k
802.11ax HEW20_Nss2,(MCS0)_2TX	0.964	0.16	781.25u	3k
802.11ax HEW40_Nss2,(MCS0)_2TX	0.932	0.31	423.438u	3k
802.11ax HEW80_Nss2,(MCS0)_2TX	0.892	0.5	242.187u	10k

Beamforming

Sample 1_Radio 1

Mode	DC	DCF(dB)	T(s)	VBW(Hz) $\geq 1/T$
802.11ac VHT20-BF_Nss1,(MCS0)_2TX	0.902	0.45	1.95m	1k
802.11ac VHT40-BF_Nss1,(MCS0)_2TX	0.906	0.43	2.798m	1k
802.11ac VHT80-BF_Nss1,(MCS0)_2TX	0.915	0.39	3.43m	300
802.11ax HEW20-BF_Nss1,(MCS0)_2TX	0.879	0.56	1.503m	1k
802.11ax HEW40-BF_Nss1,(MCS0)_2TX	0.882	0.55	2.223m	1k
802.11ax HEW80-BF_Nss1,(MCS0)_2TX	0.917	0.38	3.844m	300



Sample 1_Radio 2

Mode	DC	DCF(dB)	T(s)	VBW(Hz) ≥ 1/T
802.11ac VHT20-BF_Nss1,(MCS0)_2TX	0.902	0.45	1.95m	1k
802.11ac VHT40-BF_Nss1,(MCS0)_2TX	0.906	0.43	2.798m	1k
802.11ac VHT80-BF_Nss1,(MCS0)_2TX	0.915	0.39	3.43m	300
802.11ax HEW20-BF_Nss1,(MCS0)_2TX	0.873	0.59	1.503m	1k
802.11ax HEW40-BF_Nss1,(MCS0)_2TX	0.88	0.56	2.223m	1k
802.11ax HEW80-BF_Nss1,(MCS0)_2TX	0.93	0.32	3.844m	300

Sample 2_Radio 1

Mode	DC	DCF(dB)	T(s)	VBW(Hz) ≥ 1/T
802.11ac VHT20-BF_Nss1,(MCS0)_2TX	0.893	0.49	1.95m	1k
802.11ac VHT40-BF_Nss1,(MCS0)_2TX	0.903	0.44	2.798m	1k
802.11ac VHT80-BF_Nss1,(MCS0)_2TX	0.924	0.34	3.43m	300
802.11ax HEW20-BF_Nss1,(MCS0)_2TX	0.871	0.6	1.503m	1k
802.11ax HEW40-BF_Nss1,(MCS0)_2TX	0.885	0.53	2.223m	1k
802.11ax HEW80-BF_Nss1,(MCS0)_2TX	0.919	0.37	3.844m	300

Sample 2_Radio 2

Mode	DC	DCF(dB)	T(s)	VBW(Hz) ≥ 1/T
802.11ac VHT20-BF_Nss1,(MCS0)_2TX	0.901	0.45	1.95m	1k
802.11ac VHT40-BF_Nss1,(MCS0)_2TX	0.858	0.67	2.798m	1k
802.11ac VHT80-BF_Nss1,(MCS0)_2TX	0.855	0.68	3.43m	300
802.11ax HEW20-BF_Nss1,(MCS0)_2TX	0.794	1	1.503m	1k
802.11ax HEW40-BF_Nss1,(MCS0)_2TX	0.873	0.59	2.223m	1k
802.11ax HEW80-BF_Nss1,(MCS0)_2TX	0.92	0.36	3.844m	300

Note. If DC < 0.98, the DCF was added while measuring Output power and PSD.

1.2 Testing Applied Standards

According to the specifications of the manufacturer, the EUT must comply with the requirements of the following standards:

- ◆ 47 CFR FCC Part 15
- ◆ ANSI C63.10-2013
- ◆ KDB 789033 D02 v02r01
- ◆ KDB 662911 D01 v02r01
- ◆ KDB 414788 D01 v01r01

1.3 Testing Location Information

Testing Location				
<input checked="" type="checkbox"/>	HWA YA	ADD : No. 52, Huaya 1st Rd., Guishan Dist., Taoyuan City, Taiwan (R.O.C.)	TEL : 886-3-327-3456	FAX : 886-3-327-0973
Test site Designation No. TW1190 with FCC.				
<input type="checkbox"/>	JHUBEI	ADD : No.8, Ln. 724, Bo'ai St., Zhubei City, Hsinchu County, Taiwan (R.O.C.)	TEL : 886-3-656-9065	FAX : 886-3-656-9085
Test site Designation No. TW0006 with FCC.				

Test Condition	Test Site No.	Test Engineer	Test Environment	Test Date
RF Conducted	TH01-HY	Alan	22.1~25.5°C / 62~67%	06/Jan/2020~ 30/Jan/2020
Radiated	03CH02-HY	Dexter	21.5~24.8°C / 52~56%	26/Dec/2019~ 06/Jan/2020

1.4 Measurement Uncertainty

ISO/IEC 17025 requires that an estimate of the measurement uncertainties associated with the emissions test results be included in the report. The measurement uncertainties given below are based on a 95% confidence level (based on a coverage factor (k=2))

Test Items	Uncertainty	Remark
Conducted Emission (150kHz ~ 30MHz)	3.54 dB	Confidence levels of 95%
Radiated Emission (9kHz ~ 30MHz)	1.6 dB	Confidence levels of 95%
Radiated Emission (30MHz ~ 1,000MHz)	4.3 dB	Confidence levels of 95%
Radiated Emission (1GHz ~ 18GHz)	3.9 dB	Confidence levels of 95%
Radiated Emission (18GHz ~ 40GHz)	3.5 dB	Confidence levels of 95%
Conducted Emission	1.3 dB	Confidence levels of 95%
Temperature	0.7 °C	Confidence levels of 95%
Humidity	4 %	Confidence levels of 95%



2 Test Configuration of EUT

2.1 Test Condition

Condition Item	Abbreviation/Remark	Remark
TnomVnom	Tnom	20°C
-	Vnom	120V

2.2 Test Channel Mode

Test Software Version	accessMTool_REL_3_1_0_1
-----------------------	-------------------------

Non-Beamforming Sample 1_Radio 1_1T1S

Mode	Power Setting
802.11a_Nss1,(6Mbps)_1TX	-
5260MHz	20.75
5300MHz	21
5320MHz	20.25
5500MHz	19.5
5580MHz	20.75
5700MHz	19
5720MHz Straddle 5.47-5.725GHz	20.5
5720MHz Straddle 5.725-5.85GHz	20.5
802.11ac VHT20_Nss1,(MCS0)_1TX	-
5260MHz	20.5
5300MHz	20.5
5320MHz	19.5
5500MHz	18
5580MHz	20.75
5700MHz	17.5
5720MHz Straddle 5.47-5.725GHz	20.25
5720MHz Straddle 5.725-5.85GHz	20.25
802.11ac VHT40_Nss1,(MCS0)_1TX	-
5270MHz	20.25
5310MHz	18
5510MHz	16.5
5550MHz	20.25



Mode	Power Setting
5670MHz	20.25
5710MHz Straddle 5.47-5.725GHz	20
5710MHz Straddle 5.725-5.85GHz	20
802.11ac VHT80_Nss1,(MCS0)_1TX	-
5290MHz	17.75
5530MHz	17.75
5610MHz	20.5
5690MHz Straddle 5.47-5.725GHz	20.75
5690MHz Straddle 5.725-5.85GHz	20.75
802.11ax HEW20_Nss1,(MCS0)_1TX	-
5260MHz	20.5
5300MHz	20.5
5320MHz	19.5
5500MHz	18
5580MHz	20.75
5700MHz	17.5
5720MHz Straddle 5.47-5.725GHz	20.25
5720MHz Straddle 5.725-5.85GHz	20.25
802.11ax HEW40_Nss1,(MCS0)_1TX	-
5270MHz	20.5
5310MHz	18
5510MHz	16.5
5550MHz	20.75
5670MHz	20.75
5710MHz Straddle 5.47-5.725GHz	20.5
5710MHz Straddle 5.725-5.85GHz	20.5
802.11ax HEW80_Nss1,(MCS0)_1TX	-
5290MHz	17.75
5530MHz	17.75
5610MHz	20.5
5690MHz Straddle 5.47-5.725GHz	20.75
5690MHz Straddle 5.725-5.85GHz	20.75



Sample 1_Radio 1_2T2S

Mode	Power Setting
802.11a_Nss1,(6Mbps)_2TX	-
5260MHz	18.25
5300MHz	18.25
5320MHz	18.25
5500MHz	18
5580MHz	18
5700MHz	18
5720MHz Straddle 5.47-5.725GHz	18
5720MHz Straddle 5.725-5.85GHz	18
802.11ac VHT20_Nss2,(MCS0)_2TX	-
5260MHz	20
5300MHz	20
5320MHz	19.25
5500MHz	19.25
5580MHz	20.25
5700MHz	17.25
5720MHz Straddle 5.47-5.725GHz	20
5720MHz Straddle 5.725-5.85GHz	20
802.11ac VHT40_Nss2,(MCS0)_2TX	-
5270MHz	20
5310MHz	17.25
5510MHz	15
5550MHz	19.75
5670MHz	19.5
5710MHz Straddle 5.47-5.725GHz	20
5710MHz Straddle 5.725-5.85GHz	20
802.11ac VHT80_Nss2,(MCS0)_2TX	-
5290MHz	16.75
5530MHz	17
5610MHz	20
5690MHz Straddle 5.47-5.725GHz	20
5690MHz Straddle 5.725-5.85GHz	20
802.11ax HEW20_Nss2,(MCS0)_2TX	-
5260MHz	20



Mode	Power Setting
5300MHz	20
5320MHz	19.25
5500MHz	19.25
5580MHz	20.25
5700MHz	17.25
5720MHz Straddle 5.47-5.725GHz	20
5720MHz Straddle 5.725-5.85GHz	20
802.11ax HEW40_Nss2,(MCS0)_2TX	-
5270MHz	20
5310MHz	17.25
5510MHz	15
5550MHz	19.75
5670MHz	19.5
5710MHz Straddle 5.47-5.725GHz	20
5710MHz Straddle 5.725-5.85GHz	20
802.11ax HEW80_Nss2,(MCS0)_2TX	-
5290MHz	16.75
5530MHz	17
5610MHz	20
5690MHz Straddle 5.47-5.725GHz	20
5690MHz Straddle 5.725-5.85GHz	20



Sample 1_Radio 2_1T1S

Mode	Power Setting
802.11a_Nss1,(6Mbps)_1TX	-
5260MHz	20.75
5300MHz	20.75
5320MHz	20.75
5500MHz	18
5580MHz	21.5
5700MHz	18.5
5720MHz Straddle 5.47-5.725GHz	21
5720MHz Straddle 5.725-5.85GHz	21
802.11ac VHT20_Nss1,(MCS0)_1TX	
5260MHz	20.5
5300MHz	20.5
5320MHz	19.25
5500MHz	18
5580MHz	21.25
5700MHz	15.25
5720MHz Straddle 5.47-5.725GHz	20.5
5720MHz Straddle 5.725-5.85GHz	20.5
802.11ac VHT40_Nss1,(MCS0)_1TX	
5270MHz	20.25
5310MHz	18.5
5510MHz	17.25
5550MHz	21
5670MHz	21
5710MHz Straddle 5.47-5.725GHz	20.75
5710MHz Straddle 5.725-5.85GHz	20.75
802.11ac VHT80_Nss1,(MCS0)_1TX	
5290MHz	18.5
5530MHz	17.25
5610MHz	20.5
5690MHz Straddle 5.47-5.725GHz	21
5690MHz Straddle 5.725-5.85GHz	21
802.11ax HEW20_Nss1,(MCS0)_1TX	
5260MHz	20.5



Mode	Power Setting
5300MHz	20.5
5320MHz	19.25
5500MHz	18
5580MHz	21.25
5700MHz	15.25
5720MHz Straddle 5.47-5.725GHz	20.5
5720MHz Straddle 5.725-5.85GHz	20.5
802.11ax HEW40_Nss1,(MCS0)_1TX	-
5270MHz	20.25
5310MHz	18.5
5510MHz	17.25
5550MHz	21
5670MHz	21
5710MHz Straddle 5.47-5.725GHz	20.75
5710MHz Straddle 5.725-5.85GHz	20.75
802.11ax HEW80_Nss1,(MCS0)_1TX	
5290MHz	18.5
5530MHz	17.25
5610MHz	20.5
5690MHz Straddle 5.47-5.725GHz	21
5690MHz Straddle 5.725-5.85GHz	21



Sample 1_Radio 2_2T2S

Mode	Power Setting
802.11a_Nss1,(6Mbps)_2TX	-
5260MHz	19
5300MHz	19
5320MHz	19
5500MHz	18.75
5580MHz	19
5700MHz	18
5720MHz Straddle 5.47-5.725GHz	19
5720MHz Straddle 5.725-5.85GHz	19
802.11ac VHT20_Nss2,(MCS0)_2TX	
5260MHz	20.25
5300MHz	20.25
5320MHz	18.75
5500MHz	19
5580MHz	20.5
5700MHz	17.5
5720MHz Straddle 5.47-5.725GHz	20.75
5720MHz Straddle 5.725-5.85GHz	20.75
802.11ac VHT40_Nss2,(MCS0)_2TX	
5270MHz	20.25
5310MHz	18.25
5510MHz	16.25
5550MHz	20.25
5670MHz	19.75
5710MHz Straddle 5.47-5.725GHz	21
5710MHz Straddle 5.725-5.85GHz	21
802.11ac VHT80_Nss2,(MCS0)_2TX	
5290MHz	17.5
5530MHz	17
5610MHz	20.25
5690MHz Straddle 5.47-5.725GHz	20.5
5690MHz Straddle 5.725-5.85GHz	20.5
802.11ax HEW20_Nss2,(MCS0)_2TX	
5260MHz	20.25



Mode	Power Setting
5300MHz	20.25
5320MHz	18.75
5500MHz	19
5580MHz	20.5
5700MHz	17.5
5720MHz Straddle 5.47-5.725GHz	20.75
5720MHz Straddle 5.725-5.85GHz	20.75
802.11ax HEW40_Nss2,(MCS0)_2TX	-
5270MHz	20.25
5310MHz	18.25
5510MHz	16.25
5550MHz	20.25
5670MHz	19.75
5710MHz Straddle 5.47-5.725GHz	21
5710MHz Straddle 5.725-5.85GHz	21
802.11ax HEW80_Nss2,(MCS0)_2TX	
5290MHz	17.5
5530MHz	17
5610MHz	20.25
5690MHz Straddle 5.47-5.725GHz	20.5
5690MHz Straddle 5.725-5.85GHz	20.5



Sample 2 Radio 1 Omni_1T1S

Mode	Power Setting
802.11a_Nss1,(6Mbps)_1TX	-
5260MHz	21.5
5300MHz	21.5
5320MHz	17.5
5500MHz	16
5580MHz	22.25
5700MHz	16.25
5720MHz Straddle 5.47-5.725GHz	22.5
5720MHz Straddle 5.725-5.85GHz	22.5
802.11ac VHT20_Nss1,(MCS0)_1TX	-
5260MHz	21.25
5300MHz	21
5320MHz	16.75
5500MHz	16.25
5580MHz	22
5700MHz	13.5
5720MHz Straddle 5.47-5.725GHz	22
5720MHz Straddle 5.725-5.85GHz	22
802.11ac VHT40_Nss1,(MCS0)_1TX	-
5270MHz	20.25
5310MHz	15.5
5510MHz	15
5550MHz	19.75
5670MHz	17.75
5710MHz Straddle 5.47-5.725GHz	22.25
5710MHz Straddle 5.725-5.85GHz	22.25
802.11ac VHT80_Nss1,(MCS0)_1TX	-
5290MHz	14.75
5530MHz	15
5610MHz	18.25
5690MHz Straddle 5.47-5.725GHz	21.25
5690MHz Straddle 5.725-5.85GHz	21.25
802.11ax HEW20_Nss1,(MCS0)_1TX	-
5260MHz	21.25



Mode	Power Setting
5300MHz	21
5320MHz	16.75
5500MHz	16.25
5580MHz	22
5700MHz	13.5
5720MHz Straddle 5.47-5.725GHz	22
5720MHz Straddle 5.725-5.85GHz	22
802.11ax HEW40_Nss1,(MCS0)_1TX	-
5270MHz	20.25
5310MHz	15.5
5510MHz	15
5550MHz	19.75
5670MHz	17.75
5710MHz Straddle 5.47-5.725GHz	22.25
5710MHz Straddle 5.725-5.85GHz	22.25
802.11ax HEW80_Nss1,(MCS0)_1TX	-
5290MHz	14.75
5530MHz	15
5610MHz	18.25
5690MHz Straddle 5.47-5.725GHz	21.25
5690MHz Straddle 5.725-5.85GHz	21.25



Sample 2 Radio 1 Omni_2T2S

Mode	Power Setting
802.11a_Nss1,(6Mbps)_2TX	-
5260MHz	15
5300MHz	15.25
5320MHz	15.25
5500MHz	15.25
5580MHz	15.75
5700MHz	15.25
5720MHz Straddle 5.47-5.725GHz	15.75
5720MHz Straddle 5.725-5.85GHz	15.75
802.11ac VHT20_Nss2,(MCS0)_2TX	
5260MHz	17.75
5300MHz	17.75
5320MHz	16
5500MHz	16
5580MHz	18
5700MHz	13.5
5720MHz Straddle 5.47-5.725GHz	18.5
5720MHz Straddle 5.725-5.85GHz	18.5
802.11ac VHT40_Nss2,(MCS0)_2TX	
5270MHz	17.75
5310MHz	13.5
5510MHz	14.25
5550MHz	18
5670MHz	16
5710MHz Straddle 5.47-5.725GHz	18.5
5710MHz Straddle 5.725-5.85GHz	18.5
802.11ac VHT80_Nss2,(MCS0)_2TX	
5290MHz	12.5
5530MHz	13.75
5610MHz	17.5
5690MHz Straddle 5.47-5.725GHz	18
5690MHz Straddle 5.725-5.85GHz	18
802.11ax HEW20_Nss2,(MCS0)_2TX	
5260MHz	17.75



Mode	Power Setting
5300MHz	17.75
5320MHz	16
5500MHz	16
5580MHz	18
5700MHz	13.5
5720MHz Straddle 5.47-5.725GHz	18.5
5720MHz Straddle 5.725-5.85GHz	18.5
802.11ax HEW40_Nss2,(MCS0)_2TX	
5270MHz	17.75
5310MHz	13.5
5510MHz	14.25
5550MHz	18
5670MHz	16
5710MHz Straddle 5.47-5.725GHz	18.5
5710MHz Straddle 5.725-5.85GHz	18.5
802.11ax HEW80_Nss2,(MCS0)_2TX	
5290MHz	12.5
5530MHz	13.75
5610MHz	17.5
5690MHz Straddle 5.47-5.725GHz	18
5690MHz Straddle 5.725-5.85GHz	18



Sample 2_Radio 1_Panel 1_1T1S

Mode	Power Setting
802.11a_Nss1,(6Mbps)_1TX	-
5260MHz	17.75
5300MHz	17.75
5320MHz	16.25
5500MHz	15.5
5580MHz	18
5700MHz	16
5720MHz Straddle 5.47-5.725GHz	18
5720MHz Straddle 5.725-5.85GHz	18
802.11ac VHT20_Nss1,(MCS0)_1TX	
5260MHz	17.25
5300MHz	17.5
5320MHz	16.25
5500MHz	16
5580MHz	17.5
5700MHz	13.25
5720MHz Straddle 5.47-5.725GHz	17.75
5720MHz Straddle 5.725-5.85GHz	17.75
802.11ac VHT40_Nss1,(MCS0)_1TX	
5270MHz	17.5
5310MHz	14
5510MHz	14.25
5550MHz	17.5
5670MHz	17.5
5710MHz Straddle 5.47-5.725GHz	18
5710MHz Straddle 5.725-5.85GHz	18
802.11ac VHT80_Nss1,(MCS0)_1TX	
5290MHz	13.75
5530MHz	15
5610MHz	17.5
5690MHz Straddle 5.47-5.725GHz	18
5690MHz Straddle 5.725-5.85GHz	18
802.11ax HEW20_Nss1,(MCS0)_1TX	
5260MHz	17.25



Mode	Power Setting
5300MHz	17.5
5320MHz	16.25
5500MHz	16
5580MHz	17.5
5700MHz	13.25
5720MHz Straddle 5.47-5.725GHz	17.75
5720MHz Straddle 5.725-5.85GHz	17.75
802.11ax HEW40_Nss1,(MCS0)_1TX	
5270MHz	17.5
5310MHz	14
5510MHz	14.25
5550MHz	17.5
5670MHz	17.5
5710MHz Straddle 5.47-5.725GHz	18
5710MHz Straddle 5.725-5.85GHz	18
802.11ax HEW80_Nss1,(MCS0)_1TX	
5290MHz	13.75
5530MHz	15
5610MHz	17.5
5690MHz Straddle 5.47-5.725GHz	18
5690MHz Straddle 5.725-5.85GHz	18



Sample 2_Radio 1_Panel 1_2T2S

Mode	Power Setting
802.11a_Nss1,(6Mbps)_2TX	-
5260MHz	12
5300MHz	12
5320MHz	12.25
5500MHz	11.75
5580MHz	12
5700MHz	12
5720MHz Straddle 5.47-5.725GHz	12
5720MHz Straddle 5.725-5.85GHz	12
802.11ac_VHT20_Nss2,(MCS0)_2TX	
5260MHz	13.75
5300MHz	13.75
5320MHz	13.75
5500MHz	13.5
5580MHz	14
5700MHz	14
5720MHz Straddle 5.47-5.725GHz	14.75
5720MHz Straddle 5.725-5.85GHz	14.75
802.11ac_VHT40_Nss2,(MCS0)_2TX	
5270MHz	14
5310MHz	13.5
5510MHz	14.25
5550MHz	14.5
5670MHz	14
5710MHz Straddle 5.47-5.725GHz	15
5710MHz Straddle 5.725-5.85GHz	15
802.11ac_VHT80_Nss2,(MCS0)_2TX	
5290MHz	12.25
5530MHz	13.5
5610MHz	14.25
5690MHz Straddle 5.47-5.725GHz	14.75
5690MHz Straddle 5.725-5.85GHz	14.75
802.11ax_HEW20_Nss2,(MCS0)_2TX	
5260MHz	13.75



Mode	Power Setting
5300MHz	13.75
5320MHz	13.75
5500MHz	13.5
5580MHz	14
5700MHz	14
5720MHz Straddle 5.47-5.725GHz	14.75
5720MHz Straddle 5.725-5.85GHz	14.75
802.11ax HEW40_Nss2,(MCS0)_2TX	
5270MHz	14
5310MHz	13.5
5510MHz	14.25
5550MHz	14.5
5670MHz	14
5710MHz Straddle 5.47-5.725GHz	15
5710MHz Straddle 5.725-5.85GHz	15
802.11ax HEW80_Nss2,(MCS0)_2TX	
5290MHz	12.25
5530MHz	13.5
5610MHz	14.25
5690MHz Straddle 5.47-5.725GHz	14.75
5690MHz Straddle 5.725-5.85GHz	14.75



Sample 2_Radio 2_Omni_1T1S

Mode	Power Setting
802.11a_Nss1,(6Mbps)_1TX	-
5260MHz	22.75
5300MHz	22.5
5320MHz	19.5
5500MHz	16.75
5580MHz	22.25
5700MHz	18
5720MHz Straddle 5.47-5.725GHz	23
5720MHz Straddle 5.725-5.85GHz	23
802.11ac VHT20_Nss1,(MCS0)_1TX	
5260MHz	22.25
5300MHz	22
5320MHz	18.25
5500MHz	17.25
5580MHz	22.25
5700MHz	15
5720MHz Straddle 5.47-5.725GHz	22.75
5720MHz Straddle 5.725-5.85GHz	22.75
802.11ac VHT40_Nss1,(MCS0)_1TX	
5270MHz	21.25
5310MHz	15.75
5510MHz	15.25
5550MHz	20.25
5670MHz	19
5710MHz Straddle 5.47-5.725GHz	22.25
5710MHz Straddle 5.725-5.85GHz	22.25
802.11ac VHT80_Nss1,(MCS0)_1TX	
5290MHz	15.75
5530MHz	15.25
5610MHz	19
5690MHz Straddle 5.47-5.725GHz	22.25
5690MHz Straddle 5.725-5.85GHz	22.25
802.11ax HEW20_Nss1,(MCS0)_1TX	
5260MHz	22.25



Mode	Power Setting
5300MHz	22
5320MHz	18.25
5500MHz	17.25
5580MHz	22.25
5700MHz	15
5720MHz Straddle 5.47-5.725GHz	22.75
5720MHz Straddle 5.725-5.85GHz	22.75
802.11ax HEW40_Nss1,(MCS0)_1TX	
5270MHz	21.25
5310MHz	15.75
5510MHz	15.25
5550MHz	20.25
5670MHz	19
5710MHz Straddle 5.47-5.725GHz	22.25
5710MHz Straddle 5.725-5.85GHz	22.25
802.11ax HEW80_Nss1,(MCS0)_1TX	
5290MHz	15.75
5530MHz	15.25
5610MHz	19
5690MHz Straddle 5.47-5.725GHz	22.25
5690MHz Straddle 5.725-5.85GHz	22.25



Sample 2_Radio 2_Omni_2T2S

Mode	Power Setting
802.11a_Nss1,(6Mbps)_2TX	-
5260MHz	16
5300MHz	16
5320MHz	16
5500MHz	15.25
5580MHz	16
5700MHz	16.5
5720MHz Straddle 5.47-5.725GHz	16.5
5720MHz Straddle 5.725-5.85GHz	16.5
802.11ac_VHT20_Nss2,(MCS0)_2TX	
5260MHz	19
5300MHz	19
5320MHz	16.75
5500MHz	16.25
5580MHz	18.75
5700MHz	14.75
5720MHz Straddle 5.47-5.725GHz	18.75
5720MHz Straddle 5.725-5.85GHz	18.75
802.11ac_VHT40_Nss2,(MCS0)_2TX	
5270MHz	19
5310MHz	13.25
5510MHz	13.25
5550MHz	17.25
5670MHz	15.5
5710MHz Straddle 5.47-5.725GHz	19
5710MHz Straddle 5.725-5.85GHz	19
802.11ac_VHT80_Nss2,(MCS0)_2TX	
5290MHz	12.25
5530MHz	12.25
5610MHz	16.75
5690MHz Straddle 5.47-5.725GHz	19
5690MHz Straddle 5.725-5.85GHz	19
802.11ax_HEW20_Nss2,(MCS0)_2TX	
5260MHz	19



Mode	Power Setting
5300MHz	19
5320MHz	16.75
5500MHz	16.25
5580MHz	18.75
5700MHz	14.75
5720MHz Straddle 5.47-5.725GHz	18.75
5720MHz Straddle 5.725-5.85GHz	18.75
802.11ax HEW40_Nss2,(MCS0)_2TX	
5270MHz	19
5310MHz	13.25
5510MHz	13.25
5550MHz	17.25
5670MHz	15.5
5710MHz Straddle 5.47-5.725GHz	19
5710MHz Straddle 5.725-5.85GHz	19
802.11ax HEW80_Nss2,(MCS0)_2TX	
5290MHz	12.25
5530MHz	12.25
5610MHz	16.75
5690MHz Straddle 5.47-5.725GHz	19
5690MHz Straddle 5.725-5.85GHz	19



Sample 2_Radio 2_Panel 1_1T1S

Mode	Power Setting
802.11a_Nss1,(6Mbps)_1TX	-
5260MHz	18
5300MHz	18
5320MHz	18
5500MHz	16.5
5580MHz	18.25
5700MHz	18
5720MHz Straddle 5.47-5.725GHz	18.25
5720MHz Straddle 5.725-5.85GHz	18.25
802.11ac VHT20_Nss1,(MCS0)_1TX	
5260MHz	17.75
5300MHz	17.5
5320MHz	17.5
5500MHz	17.25
5580MHz	18
5700MHz	15.25
5720MHz Straddle 5.47-5.725GHz	18.25
5720MHz Straddle 5.725-5.85GHz	18.25
802.11ac VHT40_Nss1,(MCS0)_1TX	
5270MHz	17.75
5310MHz	16
5510MHz	15.5
5550MHz	17.5
5670MHz	17.5
5710MHz Straddle 5.47-5.725GHz	18
5710MHz Straddle 5.725-5.85GHz	18
802.11ac VHT80_Nss1,(MCS0)_1TX	
5290MHz	16.25
5530MHz	15.5
5610MHz	17.5
5690MHz Straddle 5.47-5.725GHz	18
5690MHz Straddle 5.725-5.85GHz	18
802.11ax HEW20_Nss1,(MCS0)_1TX	
5260MHz	17.75



Mode	Power Setting
5300MHz	17.5
5320MHz	17.5
5500MHz	17.25
5580MHz	18
5700MHz	15.25
5720MHz Straddle 5.47-5.725GHz	18.25
5720MHz Straddle 5.725-5.85GHz	18.25
802.11ax HEW40_Nss1,(MCS0)_1TX	
5270MHz	17.75
5310MHz	16
5510MHz	15.5
5550MHz	17.5
5670MHz	17.5
5710MHz Straddle 5.47-5.725GHz	18
5710MHz Straddle 5.725-5.85GHz	18
802.11ax HEW80_Nss1,(MCS0)_1TX	
5290MHz	16.25
5530MHz	15.5
5610MHz	17.5
5690MHz Straddle 5.47-5.725GHz	18
5690MHz Straddle 5.725-5.85GHz	18



Sample 2_Radio 2_Panel 1_2T2S

Mode	Power Setting
802.11a_Nss1,(6Mbps)_2TX	-
5260MHz	12.5
5300MHz	12.5
5320MHz	12.5
5500MHz	12.5
5580MHz	12.5
5700MHz	12.5
5720MHz Straddle 5.47-5.725GHz	12.5
5720MHz Straddle 5.725-5.85GHz	12.5
802.11ac VHT20_Nss2,(MCS0)_2TX	
5260MHz	14.5
5300MHz	14.5
5320MHz	14.5
5500MHz	14.5
5580MHz	14.5
5700MHz	14.25
5720MHz Straddle 5.47-5.725GHz	14.75
5720MHz Straddle 5.725-5.85GHz	14.75
802.11ac VHT40_Nss2,(MCS0)_2TX	
5270MHz	14.5
5310MHz	13.75
5510MHz	13.75
5550MHz	14.75
5670MHz	14.5
5710MHz Straddle 5.47-5.725GHz	15
5710MHz Straddle 5.725-5.85GHz	15
802.11ac VHT80_Nss2,(MCS0)_2TX	
5290MHz	14
5530MHz	13.75
5610MHz	14.5
5690MHz Straddle 5.47-5.725GHz	14.75
5690MHz Straddle 5.725-5.85GHz	14.75
802.11ax HEW20_Nss2,(MCS0)_2TX	
5260MHz	14.5



Mode	Power Setting
5300MHz	14.5
5320MHz	14.5
5500MHz	14.5
5580MHz	14.5
5700MHz	14.25
5720MHz Straddle 5.47-5.725GHz	14.75
5720MHz Straddle 5.725-5.85GHz	14.75
802.11ax HEW40_Nss2,(MCS0)_2TX	
5270MHz	14.5
5310MHz	13.75
5510MHz	13.75
5550MHz	14.75
5670MHz	14.5
5710MHz Straddle 5.47-5.725GHz	15
5710MHz Straddle 5.725-5.85GHz	15
802.11ax HEW80_Nss2,(MCS0)_2TX	
5290MHz	14
5530MHz	13.75
5610MHz	14.5
5690MHz Straddle 5.47-5.725GHz	14.75
5690MHz Straddle 5.725-5.85GHz	14.75



Beamforming

Test Software Version	Dos
-----------------------	-----

Sample 1_Radio 1_2T1S

Mode	Power Setting
802.11ac VHT20-BF_Nss1,(MCS0)_2TX	-
5260MHz	17
5300MHz	17
5320MHz	17
5500MHz	17.25
5580MHz	17.5
5700MHz	17.5
5720MHz Straddle 5.47-5.725GHz	17.5
5720MHz Straddle 5.725-5.85GHz	17.5
802.11ac VHT40-BF_Nss1,(MCS0)_2TX	
5270MHz	17.5
5310MHz	16.75
5510MHz	15.5
5550MHz	17.75
5670MHz	17.75
5710MHz Straddle 5.47-5.725GHz	17.25
5710MHz Straddle 5.725-5.85GHz	17.25
802.11ac VHT80-BF_Nss1,(MCS0)_2TX	
5290MHz	17
5530MHz	15.75
5610MHz	17.75
5690MHz Straddle 5.47-5.725GHz	16.75
5690MHz Straddle 5.725-5.85GHz	16.75
802.11ax HEW20-BF_Nss1,(MCS0)_2TX	
5260MHz	17
5300MHz	17
5320MHz	17
5500MHz	17.25
5580MHz	17.5
5700MHz	17.5
5720MHz Straddle 5.47-5.725GHz	17.5



Mode	Power Setting
5720MHz Straddle 5.725-5.85GHz	17.5
802.11ax HEW40-BF_Nss1,(MCS0)_2TX	
5270MHz	17.5
5310MHz	16.75
5510MHz	15.5
5550MHz	17.75
5670MHz	17.75
5710MHz Straddle 5.47-5.725GHz	17.25
5710MHz Straddle 5.725-5.85GHz	17.25
802.11ax HEW80-BF_Nss1,(MCS0)_2TX	-
5290MHz	17
5530MHz	15.75
5610MHz	17.75
5690MHz Straddle 5.47-5.725GHz	16.75
5690MHz Straddle 5.725-5.85GHz	16.75



Sample 1_Radio 2_2T1S

Mode	Power Setting
802.11ac VHT20-BF_Nss1,(MCS0)_2TX	-
5260MHz	18
5300MHz	17.75
5320MHz	17.75
5500MHz	18
5580MHz	18.25
5700MHz	17
5720MHz Straddle 5.47-5.725GHz	18
5720MHz Straddle 5.725-5.85GHz	18
802.11ac VHT40-BF_Nss1,(MCS0)_2TX	
5270MHz	18
5310MHz	16.75
5510MHz	16
5550MHz	18
5670MHz	18
5710MHz Straddle 5.47-5.725GHz	18
5710MHz Straddle 5.725-5.85GHz	18
802.11ac VHT80-BF_Nss1,(MCS0)_2TX	
5290MHz	16.75
5530MHz	15.75
5610MHz	17.5
5690MHz Straddle 5.47-5.725GHz	17.25
5690MHz Straddle 5.725-5.85GHz	17.25
802.11ax HEW20-BF_Nss1,(MCS0)_2TX	
5260MHz	18
5300MHz	17.75
5320MHz	17.75
5500MHz	18
5580MHz	18.25
5700MHz	17
5720MHz Straddle 5.47-5.725GHz	18
5720MHz Straddle 5.725-5.85GHz	18
802.11ax HEW40-BF_Nss1,(MCS0)_2TX	
5270MHz	18



Mode	Power Setting
5310MHz	16.75
5510MHz	16
5550MHz	18
5670MHz	18
5710MHz Straddle 5.47-5.725GHz	18
5710MHz Straddle 5.725-5.85GHz	18
802.11ax HEW80-BF_Nss1,(MCS0)_2TX	
5290MHz	16.75
5530MHz	15.75
5610MHz	17.5
5690MHz Straddle 5.47-5.725GHz	17.25
5690MHz Straddle 5.725-5.85GHz	17.25



Sample 2_Radio 1_Omni_2T1S

Mode	Power Setting
802.11ac VHT20-BF_Nss1,(MCS0)_2TX	-
5260MHz	14.5
5300MHz	14.5
5320MHz	14.75
5500MHz	14.5
5580MHz	14.5
5700MHz	14.5
5720MHz Straddle 5.47-5.725GHz	14.5
5720MHz Straddle 5.725-5.85GHz	14.5
802.11ac VHT40-BF_Nss1,(MCS0)_2TX	-
5270MHz	14.75
5310MHz	14.75
5510MHz	14.25
5550MHz	14.75
5670MHz	14.75
5710MHz Straddle 5.47-5.725GHz	15
5710MHz Straddle 5.725-5.85GHz	15
802.11ac VHT80-BF_Nss1,(MCS0)_2TX	-
5290MHz	14.5
5530MHz	14.5
5610MHz	15
5690MHz Straddle 5.47-5.725GHz	15
5690MHz Straddle 5.725-5.85GHz	15
802.11ax HEW20-BF_Nss1,(MCS0)_2TX	-
5260MHz	14.5
5300MHz	14.5
5320MHz	14.75
5500MHz	14.5
5580MHz	14.5
5700MHz	14.5
5720MHz Straddle 5.47-5.725GHz	14.5
5720MHz Straddle 5.725-5.85GHz	14.5
802.11ax HEW40-BF_Nss1,(MCS0)_2TX	-
5270MHz	14.75



Mode	Power Setting
5310MHz	14.75
5510MHz	14.25
5550MHz	14.75
5670MHz	14.75
5710MHz Straddle 5.47-5.725GHz	15
5710MHz Straddle 5.725-5.85GHz	15
802.11ax HEW80-BF_Nss1,(MCS0)_2TX	-
5290MHz	14.5
5530MHz	14.5
5610MHz	15
5690MHz Straddle 5.47-5.725GHz	15
5690MHz Straddle 5.725-5.85GHz	15



Sample 2 Radio 1 Panel 1_2T1S

Mode	Power Setting
802.11ac VHT20-BF_Nss1,(MCS0)_2TX	-
5260MHz	11.25
5300MHz	11.25
5320MHz	11.25
5500MHz	11.25
5580MHz	11.25
5700MHz	11.25
5720MHz Straddle 5.47-5.725GHz	11.5
5720MHz Straddle 5.725-5.85GHz	11.5
802.11ac VHT40-BF_Nss1,(MCS0)_2TX	
5270MHz	11.5
5310MHz	11.5
5510MHz	11.5
5550MHz	11.75
5670MHz	11.5
5710MHz Straddle 5.47-5.725GHz	12.5
5710MHz Straddle 5.725-5.85GHz	12.5
802.11ac VHT80-BF_Nss1,(MCS0)_2TX	
5290MHz	11.25
5530MHz	11.25
5610MHz	11.75
5690MHz Straddle 5.47-5.725GHz	11.75
5690MHz Straddle 5.725-5.85GHz	11.75
802.11ax HEW20-BF_Nss1,(MCS0)_2TX	
5260MHz	11.25
5300MHz	11.25
5320MHz	11.25
5500MHz	11.25
5580MHz	11.25
5700MHz	11.25
5720MHz Straddle 5.47-5.725GHz	11.5
5720MHz Straddle 5.725-5.85GHz	11.5
802.11ax HEW40-BF_Nss1,(MCS0)_2TX	
5270MHz	11.5



Mode	Power Setting
5310MHz	11.5
5510MHz	11.5
5550MHz	11.75
5670MHz	11.5
5710MHz Straddle 5.47-5.725GHz	12.5
5710MHz Straddle 5.725-5.85GHz	12.5
802.11ax HEW80-BF_Nss1,(MCS0)_2TX	
5290MHz	11.25
5530MHz	11.25
5610MHz	11.75
5690MHz Straddle 5.47-5.725GHz	11.75
5690MHz Straddle 5.725-5.85GHz	11.75



Sample 2 Radio 2 Omni_2T1S

Mode	Power Setting
802.11ac VHT20-BF_Nss1,(MCS0)_2TX	-
5260MHz	15
5300MHz	14.75
5320MHz	14.75
5500MHz	14.75
5580MHz	15
5700MHz	14.25
5720MHz Straddle 5.47-5.725GHz	14.5
5720MHz Straddle 5.725-5.85GHz	14.5
802.11ac VHT40-BF_Nss1,(MCS0)_2TX	
5270MHz	14.75
5310MHz	14
5510MHz	13
5550MHz	15
5670MHz	15
5710MHz Straddle 5.47-5.725GHz	15
5710MHz Straddle 5.725-5.85GHz	15
802.11ac VHT80-BF_Nss1,(MCS0)_2TX	
5290MHz	13
5530MHz	13
5610MHz	14.75
5690MHz Straddle 5.47-5.725GHz	14.5
5690MHz Straddle 5.725-5.85GHz	14.5
802.11ax HEW20-BF_Nss1,(MCS0)_2TX	
5260MHz	15
5300MHz	14.75
5320MHz	14.75
5500MHz	14.75
5580MHz	15
5700MHz	14.25
5720MHz Straddle 5.47-5.725GHz	14.5
5720MHz Straddle 5.725-5.85GHz	14.5
802.11ax HEW40-BF_Nss1,(MCS0)_2TX	
5270MHz	14.75



Mode	Power Setting
5310MHz	14
5510MHz	13
5550MHz	15
5670MHz	15
5710MHz Straddle 5.47-5.725GHz	15
5710MHz Straddle 5.725-5.85GHz	15
802.11ax HEW80-BF_Nss1,(MCS0)_2TX	
5290MHz	13
5530MHz	13
5610MHz	14.75
5690MHz Straddle 5.47-5.725GHz	14.5
5690MHz Straddle 5.725-5.85GHz	14.5



Sample 2 Radio 2 Panel 1_2T1S



Mode	Power Setting
802.11ac VHT20-BF_Nss1,(MCS0)_2TX	-
5260MHz	12
5300MHz	12
5320MHz	11.75
5500MHz	12
5580MHz	12.25
5700MHz	12
5720MHz Straddle 5.47-5.725GHz	12.25
5720MHz Straddle 5.725-5.85GHz	12.25
802.11ac VHT40-BF_Nss1,(MCS0)_2TX	
5270MHz	12
5310MHz	12
5510MHz	12.25
5550MHz	12.25
5670MHz	12.25
5710MHz Straddle 5.47-5.725GHz	12.75
5710MHz Straddle 5.725-5.85GHz	12.75
802.11ac VHT80-BF_Nss1,(MCS0)_2TX	
5290MHz	11.75
5530MHz	12
5610MHz	12
5690MHz Straddle 5.47-5.725GHz	12.25
5690MHz Straddle 5.725-5.85GHz	12.25
802.11ax HEW20-BF_Nss1,(MCS0)_2TX	
5260MHz	12
5300MHz	12
5320MHz	11.75
5500MHz	12
5580MHz	12.25
5700MHz	12
5720MHz Straddle 5.47-5.725GHz	12.25
5720MHz Straddle 5.725-5.85GHz	12.25
802.11ax HEW40-BF_Nss1,(MCS0)_2TX	
5270MHz	12



Mode	Power Setting
5310MHz	12
5510MHz	12.25
5550MHz	12.25
5670MHz	12.25
5710MHz Straddle 5.47-5.725GHz	12.75
5710MHz Straddle 5.725-5.85GHz	12.75
802.11ax HEW80-BF_Nss1,(MCS0)_2TX	
5290MHz	11.75
5530MHz	12
5610MHz	12
5690MHz Straddle 5.47-5.725GHz	12.25
5690MHz Straddle 5.725-5.85GHz	12.25

2.3 The Worst Case Measurement Configuration

The Worst Case Mode for Following Conformance Tests	
Tests Item	Emission Bandwidth Maximum Conducted Output Power Peak Power Spectral Density
Test Condition	Conducted measurement at transmit chains

The Worst Case Mode for Following Conformance Tests			
Tests Item	Unwanted Emissions		
Test Condition	Radiated measurement If EUT consist of multiple antenna assembly (multiple antenna are used in EUT regardless of spatial multiplexing MIMO configuration), the radiated test should be performed with highest antenna gain of each antenna type.		
Operating Mode < 1GHz	CTX		
1	PoE Mode (Non-Beamforming_Sample 1_Radio 1_1T1S)		
2	PoE Mode (Non-Beamforming_Sample 1_Radio 1_2T2S)		
3	PoE Mode (Non-Beamforming_Sample 1_Radio 2_1T1S)		
4	PoE Mode (Non-Beamforming_Sample 1_Radio 2_2T2S)		
5	PoE Mode (Non-Beamforming_Sample 2_Radio 1_Omni_1T1S)		
6	PoE Mode (Non-Beamforming_Sample 2_Radio 1_Omni_2T2S)		
7	PoE Mode (Non-Beamforming_Sample 2_Radio 1_Panel 1_1T1S)		
8	PoE Mode (Non-Beamforming_Sample 2_Radio 1_Panel 1_2T2S)		
9	PoE Mode (Non-Beamforming_Sample 2_Radio 2_Omni_1T1S)		
10	PoE Mode (Non-Beamforming_Sample 2_Radio 2_Omni_2T2S)		
11	PoE Mode (Non-Beamforming_Sample 2_Radio 2_Panel 1_1T1S)		
12	PoE Mode (Non-Beamforming_Sample 2_Radio 2_Panel 1_2T2S)		
13	PoE Mode (Beamforming_Sample 1_Radio 1_2T1S)		
14	PoE Mode (Beamforming_Sample 1_Radio 2_2T1S)		
15	PoE Mode (Beamforming_Sample 2_Radio 1_Omni_2T1S)		
16	PoE Mode (Beamforming_Sample 2_Radio 1_Panel 1_2T1S)		
17	PoE Mode (Beamforming_Sample 2_Radio 2_Omni_2T1S)		
18	PoE Mode (Beamforming_Sample 2_Radio 2_Panel 1_2T1S)		
Operating Mode > 1GHz	CTX		
Orthogonal Planes of EUT	X Plane	Y Plane	Z Plane
			



Worst Planes of EUT	V	V	V
---------------------	---	---	---

The Worst Case Mode for Following Conformance Tests	
Tests Item	Simultaneous Transmission Analysis
Operating Mode	CTX
1	Radio 1 WLAN 2.4G+ Radio 2 WLAN 5G+ Bluetooth
2	Radio 1 WLAN 2.4G+ Radio 2 WLAN 5G+ Thread
3	Radio 1 WLAN 5G+ Radio 2 WLAN 5G+ Bluetooth
4	Radio 1 WLAN 5G+ Radio 2 WLAN 5G+ Thread
Refer to Sporton Test Report No.: FA992608-01 for Co-location RF Exposure Evaluation.	



2.4 Support Equipment

Support Equipment – RF Conducted				
No.	Equipment	Brand Name	Model Name	FCC ID
1	Notebook	DELL	PP13S	R33002 / DOC
2	Adapter for NB	DELL	AA90PM111	R35737 / DOC
3	Notebook	DELL	PP13S	R33002 / DOC
4	Adapter for NB	DELL	AA90PM111	R35737 / DOC
5	PoE	EnGenius	EPA5006GP	-

Note: Support equipment No.5 was provided by customer.

Support Equipment – Radiated Emission				
No.	Equipment	Brand Name	Model Name	FCC ID
1	Load	Sporton		-
2	USB 2.0 Flash	Transcend	D24425 2101	-
3	LAN Cable	Power Sync	UTP5-01	-
4	LAN Cable	Power Sync	CAT-6E-10	-
5	PoE	EnGenius	EPA5006GP	Remote
6	PoE for BF	EnGenius	EPA5006GP	Remote
7	AC Power Cable	-	-	Remote
8	Notebook	DELL	PP13S	Remote
9	LAN Cable	Power Sync	CAT-6E-01	Remote
10	Adapter for NB	DELL	AA90PM111	Remote

Note: Support equipment No.5,6,7 were provided by customer.

2.5 Test Setup Diagram

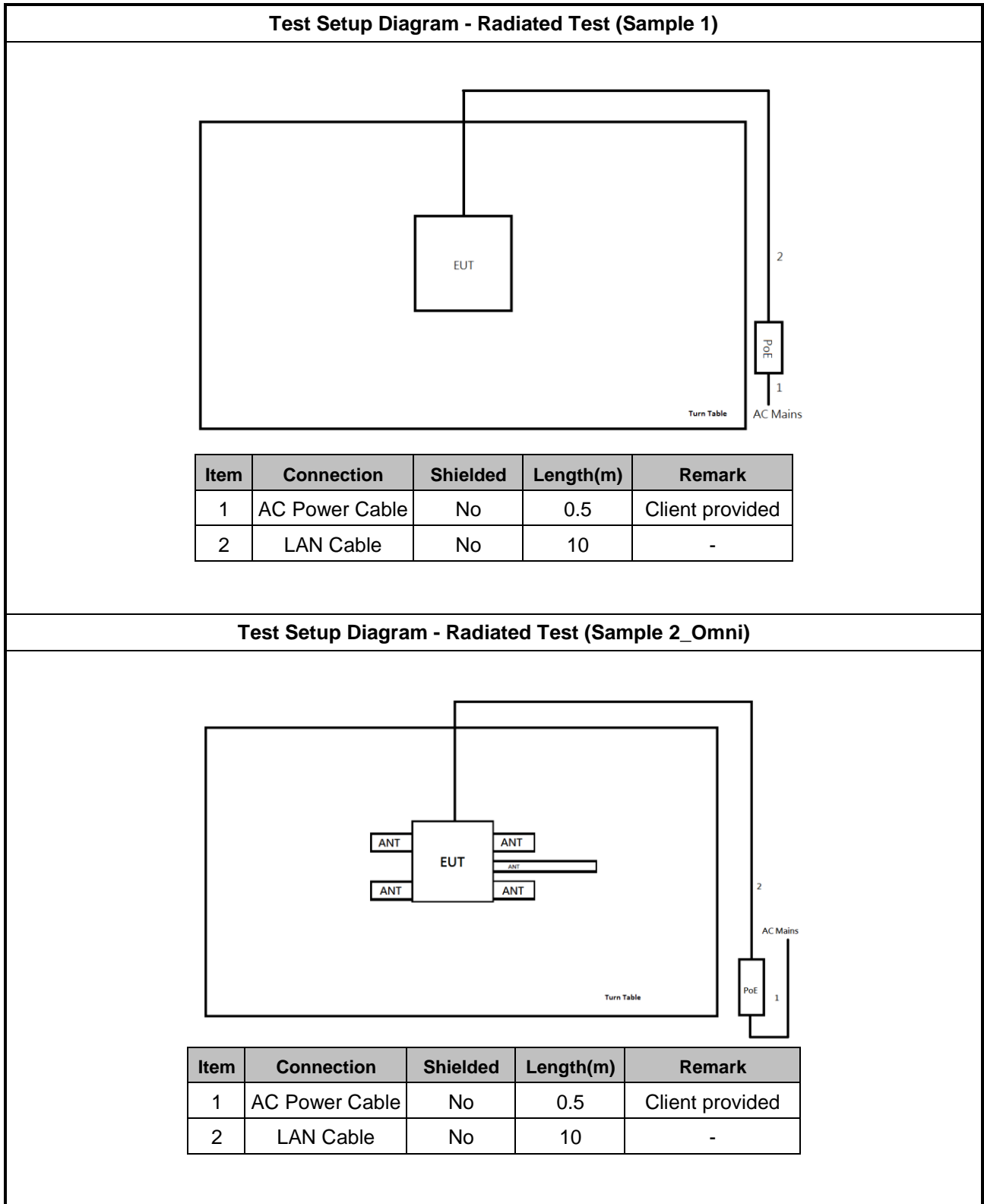

Test Setup Diagram - Radiated Test (Sample 2_Panel 1)

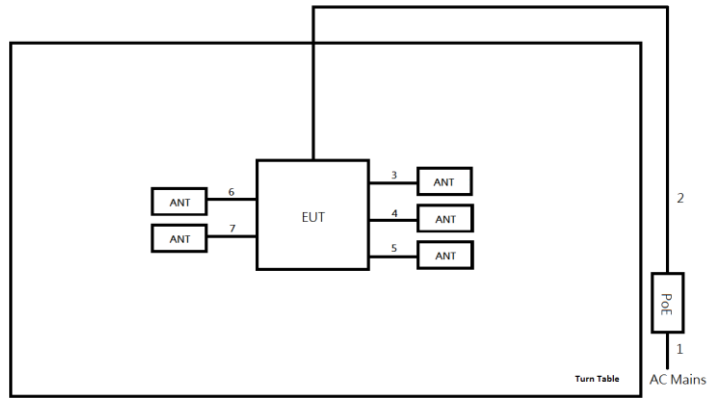

Item	Connection	Shielded	Length(m)	Remark
1	AC Power Cable	No	0.5	Client provided
2	LAN Cable	No	10	-
3	Antenna Cable	No	0.3	-
4	Antenna Cable	No	0.3	-
5	Antenna Cable	No	0.3	-
6	Antenna Cable	No	0.3	-
7	Antenna Cable	No	0.3	-

Test Setup Diagram - Radiated Test (Sample 2_Panel 2)

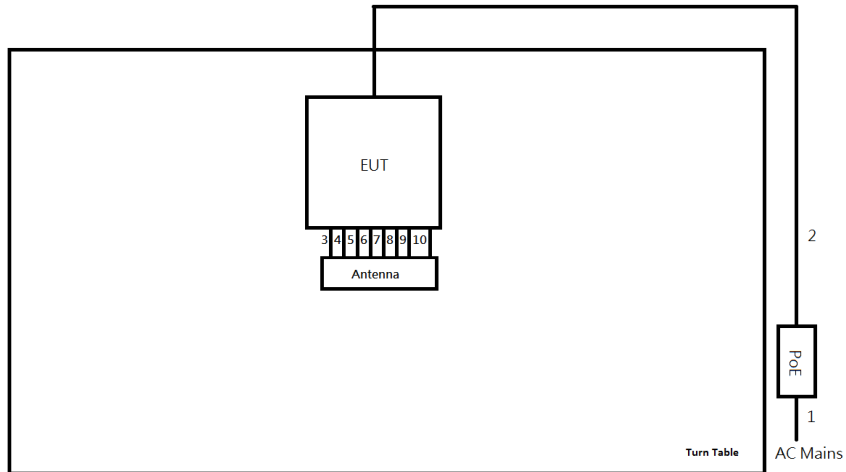

Item	Connection	Shielded	Length(m)	Remark
1	AC Power Cable	No	0.5	Client provided
2	LAN Cable	No	10	-
3	Antenna Cable	No	1.6	-
4	Antenna Cable	No	1.6	-
5	Antenna Cable	No	1.6	-
6	Antenna Cable	No	1.6	-
7	Antenna Cable	No	1.6	-
8	Antenna Cable	No	1.6	-
9	Antenna Cable	No	1.6	-
10	Antenna Cable	No	1.6	-

3 Transmitter Test Result

3.1 Emission Bandwidth

3.1.1 Emission Bandwidth Limit

Emission Bandwidth Limit	
UNII Devices	
<input type="checkbox"/>	For the 5.15-5.25 GHz band, N/A
<input checked="" type="checkbox"/>	For the 5.25-5.35 GHz band, N/A
<input checked="" type="checkbox"/>	For the 5.47-5.725 GHz band, N/A
<input checked="" type="checkbox"/>	For the 5.725-5.85 GHz band, 6 dB emission bandwidth \geq 500kHz.

3.1.2 Measuring Instruments

Refer a test equipment and calibration data table in this test report.

3.1.3 Test Procedures

Test Method	
<ul style="list-style-type: none"> ▪ For the emission bandwidth shall be measured using one of the options below: 	
<input checked="" type="checkbox"/>	Refer as KDB 789033, clause C for EBW and clause D for OBW measurement.
<input type="checkbox"/>	Refer as ANSI C63.10, clause 6.9.3 for occupied bandwidth testing.
<input type="checkbox"/>	Refer as IC RSS-Gen, clause 6.7 for bandwidth testing.

3.1.4 Test Setup

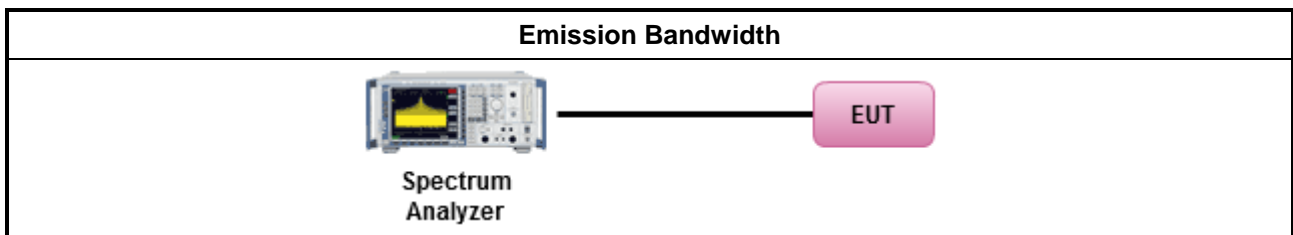

3.1.5 Test Result of Emission Bandwidth

Refer as Appendix A

3.2 Maximum Conducted Output Power

3.2.1 Maximum Conducted Output Power Limit

Maximum Conducted Output Power Limit	
UNII Devices	
<input type="checkbox"/> For the 5.15-5.25 GHz band:	
	<ul style="list-style-type: none"> ▪ Outdoor AP: the maximum conducted output power (P_{Out}) shall not exceed the lesser of 1 W. If $G_{TX} > 6$ dBi, then $P_{Out} = 30 - (G_{TX} - 6)$. e.i.r.p. at any elevation angle above 30 degrees $\leq 125mW$ [21dBm] ▪ Indoor AP: the maximum conducted output power (P_{Out}) shall not exceed the lesser of 1 W. If $G_{TX} > 6$ dBi, then $P_{Out} = 30 - (G_{TX} - 6)$ ▪ Point-to-point AP: the maximum conducted output power (P_{Out}) shall not exceed the lesser of 1 W. If $G_{TX} > 23$ dBi, then $P_{Out} = 30 - (G_{TX} - 23)$. ▪ Mobile or Portable Client: the maximum conducted output power (P_{Out}) shall not exceed the lesser of 250 mW. If $G_{TX} > 6$ dBi, then $P_{Out} = 24 - (G_{TX} - 6)$.
<input checked="" type="checkbox"/> For the 5.25-5.35 GHz band, the maximum conducted output power (P_{Out}) shall not exceed the lesser of 250 mW or $11 \text{ dBm} + 10 \log B$, where B is the 26 dB emission bandwidth in MHz. If $G_{TX} > 6$ dBi, then $P_{Out} = 24 - (G_{TX} - 6)$.	
<input checked="" type="checkbox"/> For the 5.47-5.725 GHz band, the maximum conducted output power (P_{Out}) shall not exceed the lesser of 250 mW or $11 \text{ dBm} + 10 \log B$, where B is the 26 dB emission bandwidth in MHz. If $G_{TX} > 6$ dBi, then $P_{Out} = 24 - (G_{TX} - 6)$.	
<input checked="" type="checkbox"/> For the 5.725-5.85 GHz band:	
	<ul style="list-style-type: none"> ▪ Point-to-multipoint systems (P2M): the maximum conducted output power (P_{Out}) shall not exceed the lesser of 1 W. If $G_{TX} > 6$ dBi, then $P_{Out} = 30 - (G_{TX} - 6)$. ▪ Point-to-point systems (P2P): the maximum conducted output power (P_{Out}) shall not exceed the lesser of 1 W.
P_{Out} = maximum conducted output power in dBm, G_{TX} = the maximum transmitting antenna directional gain in dBi.	

3.2.2 Measuring Instruments

Refer a test equipment and calibration data table in this test report.

3.2.3 Test Procedures

Test Method	
<ul style="list-style-type: none"> Maximum Conducted Output Power 	
	Duty cycle $\geq 98\%$
<input checked="" type="checkbox"/>	Refer as KDB 789033, clause E Method SA-2 (spectral trace averaging).
	Duty cycle $< 98\%$
<input type="checkbox"/>	Refer as KDB 789033, clause E Method SA-2 Alt. (RMS detection with slow sweep speed)
Wideband RF power meter and average over on/off periods with duty factor	
<input checked="" type="checkbox"/>	Refer as KDB 789033, clause E Method PM (using an RF average power meter).
<ul style="list-style-type: none"> For conducted measurement. 	
	<ul style="list-style-type: none"> If the EUT supports multiple transmit chains using options given below: Refer as KDB 662911, In-band power measurements. Using the measure-and-sum approach, measured all transmit ports individually. Sum the power (in linear power units e.g., mW) of all ports for each individual sample and save them.
	<ul style="list-style-type: none"> If multiple transmit chains, EIRP calculation could be following as methods: $P_{total} = P_1 + P_2 + \dots + P_n$ (calculated in linear unit [mW] and transfer to log unit [dBm]) $EIRP_{total} = P_{total} + DG$

3.2.4 Test Setup

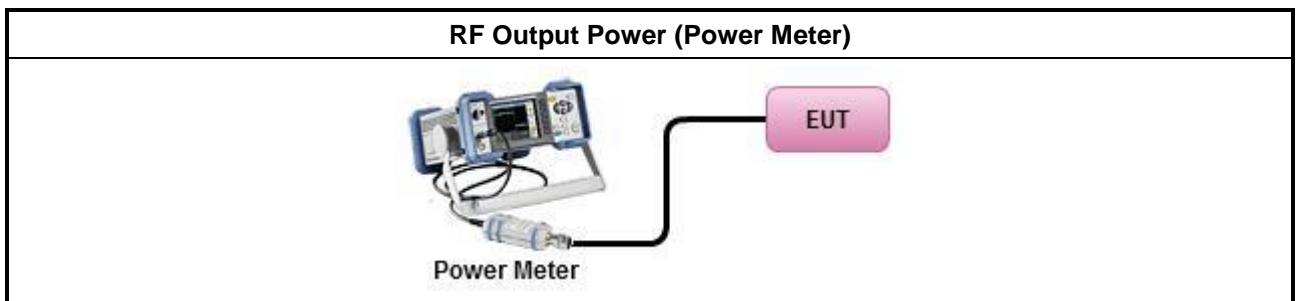
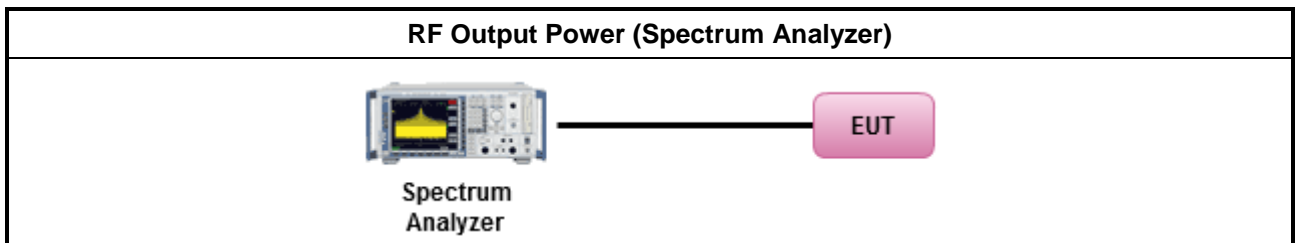

3.2.5 Test Result of Maximum Conducted Output Power

Refer as Appendix B

3.3 Peak Power Spectral Density

3.3.1 Peak Power Spectral Density Limit

Peak Power Spectral Density Limit	
UNII Devices	
<input type="checkbox"/> For the 5.15-5.25 GHz band:	
<input type="checkbox"/>	<ul style="list-style-type: none"> ▪ Outdoor AP: the peak power spectral density (PPSD) shall not exceed the lesser of 17dBm/MHz. If $G_{TX} > 6$ dBi, then $P_{Out} = 17 - (G_{TX} - 6)$. ▪ Indoor AP: the peak power spectral density (PPSD) shall not exceed the lesser of 17dBm/MHz. If $G_{TX} > 6$ dBi, then $P_{Out} = 17 - (G_{TX} - 6)$. ▪ Point-to-point AP: the peak power spectral density (PPSD) shall not exceed the lesser of 17dBm/MHz. If $G_{TX} > 23$ dBi, then $P_{Out} = 17 - (G_{TX} - 23)$. ▪ Mobile or Portable Client: the peak power spectral density (PPSD) ≤ 11 dBm/MHz. If $G_{TX} > 6$ dBi, then $PPSD = 11 - (G_{TX} - 6)$.
<input checked="" type="checkbox"/>	For the 5.25-5.35 GHz band, the peak power spectral density (PPSD) ≤ 11 dBm/MHz. If $G_{TX} > 6$ dBi, then $PPSD = 11 - (G_{TX} - 6)$.
<input checked="" type="checkbox"/>	For the 5.47-5.725 GHz band, the peak power spectral density (PPSD) ≤ 11 dBm/MHz. If $G_{TX} > 6$ dBi, then $PPSD = 11 - (G_{TX} - 6)$.
<input checked="" type="checkbox"/> For the 5.725-5.85 GHz band:	
<input checked="" type="checkbox"/>	<ul style="list-style-type: none"> ▪ Point-to-multipoint systems (P2M): the peak power spectral density (PPSD) ≤ 30 dBm/500kHz. If $G_{TX} > 6$ dBi, then $PPSD = 30 - (G_{TX} - 6)$. ▪ Point-to-point systems (P2P): the peak power spectral density (PPSD) ≤ 30 dBm/500kHz.
<p>PPSD = peak power spectral density that he same method as used to determine the conducted output power shall be used to determine the power spectral density. And power spectral density in dBm/MHz</p> <p>G_{TX} = the maximum transmitting antenna directional gain in dBi.</p>	

3.3.2 Measuring Instruments

Refer a test equipment and calibration data table in this test report.

3.3.3 Test Procedures

Test Method	
<ul style="list-style-type: none"> ▪ Peak power spectral density procedures that the same method as used to determine the conducted output power shall be used to determine the peak power spectral density and use the peak search function on the spectrum analyzer to find the peak of the spectrum. For the peak power spectral density shall be measured using below options: 	
<input type="checkbox"/>	Refer as KDB 789033, F)5) power spectral density can be measured using resolution bandwidths < 1 MHz provided that the results are integrated over 1 MHz bandwidth Duty cycle ≥ 98%
<input type="checkbox"/>	Refer as KDB 789033, clause E Method SA-2 (spectral trace averaging). Duty cycle < 98%
<input checked="" type="checkbox"/>	Refer as KDB 789033, clause E Method SA-2 Alt. (RMS detection with slow sweep speed)
<ul style="list-style-type: none"> ▪ For conducted measurement. 	
<ul style="list-style-type: none"> ▪ If the EUT supports multiple transmit chains using options given below: 	
	<ul style="list-style-type: none"> ▪ Measure and sum the spectra across the outputs. Refer as KDB 662911, In-band power spectral density (PSD). Sample all transmit ports simultaneously using a spectrum analyzer for each transmit port. Where the trace bin-by-bin of each transmit port summing can be performed. (i.e., in the first spectral bin of output 1 is summed with that in the first spectral bin of output 2 and that from the first spectral bin of output 3, and so on up to the NTX output to obtain the value for the first frequency bin of the summed spectrum.). Add up the amplitude (power) values for the different transmit chains and use this as the new data trace.
	<ul style="list-style-type: none"> ▪ If multiple transmit chains, EIRP PPSD calculation could be following as methods: $PPSD_{total} = PPSD_1 + PPSD_2 + \dots + PPSD_n$ (calculated in linear unit [mW] and transfer to log unit [dBm]) $EIRP_{total} = PPSD_{total} + DG$

3.3.4 Test Setup

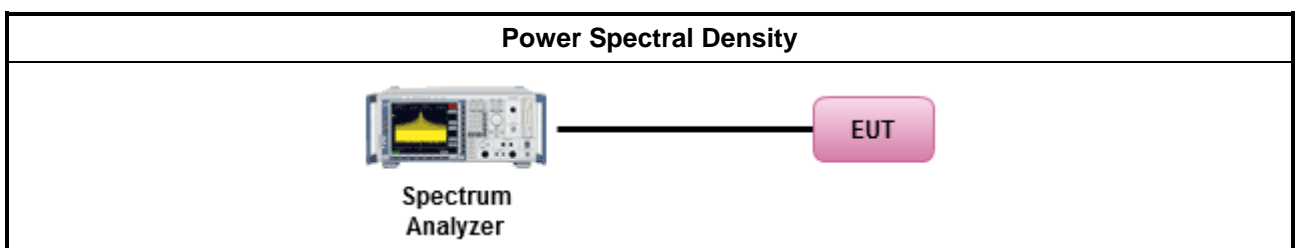

3.3.5 Test Result of Peak Power Spectral Density

Refer as Appendix C



3.4 Unwanted Emissions

3.4.1 Transmitter Radiated Unwanted Emissions Limit

Unwanted emissions below 1 GHz and restricted band emissions above 1GHz limit			
Frequency Range (MHz)	Field Strength (uV/m)	Field Strength (dBuV/m)	Measure Distance (m)
0.009~0.490	2400/F(kHz)	48.5 - 13.8	300
0.490~1.705	24000/F(kHz)	33.8 - 23	30
1.705~30.0	30	29	30
30~88	100	40	3
88~216	150	43.5	3
216~960	200	46	3
Above 960	500	54	3

Note 1: Test distance for frequencies at or above 30 MHz, measurements may be performed at a distance other than the limit distance provided they are not performed in the near field and the emissions to be measured can be detected by the measurement equipment. When performing measurements at a distance other than that specified, the results shall be extrapolated to the specified distance using an extrapolation factor of 20 dB/decade (inverse of linear distance for field-strength measurements, inverse of linear distance-squared for power-density measurements).

Note 2: Test distance for frequencies at below 30 MHz, measurements may be performed at a distance closer than the EUT limit distance; however, an attempt should be made to avoid making measurements in the near field. When performing measurements below 30 MHz at a closer distance than the limit distance, the results shall be extrapolated to the specified distance by either making measurements at a minimum of two or more distances on at least one radial to determine the proper extrapolation factor or by using the square of an inverse linear distance extrapolation factor (40 dB/decade). The test report shall specify the extrapolation method used to determine compliance of the EUT.

Note 3: Using the distance of 1m during the test for above 18 GHz, and the test value to correct for the distance factor at 3m.



Un-restricted band emissions above 1GHz Limit	
Operating Band	Limit
5.15 - 5.25 GHz	e.i.r.p. -27 dBm [68.2 dBuV/m@3m]
5.25 - 5.35 GHz	e.i.r.p. -27 dBm [68.2 dBuV/m@3m]
5.47 - 5.725 GHz	e.i.r.p. -27 dBm [68.2 dBuV/m@3m]
5.725 - 5.85 GHz	5.650-5700 GHz: e.i.r.p. -27 ~ 10 dBm [68.2 ~ 105.2 dBuV/m@3m] 5.700-5720 GHz: e.i.r.p. 10 ~ 15.6 dBm [105.2 ~ 110.8 dBuV/m@3m] 5.720-5725 GHz: e.i.r.p. 15.6 ~ 27 dBm [110.8 ~ 122.2 dBuV/m@3m] 5.850-5.855 GHz: e.i.r.p. 27 ~ 15.6 dBm [122.2 ~ 110.8 dBuV/m@3m] 5.855-5.875 GHz: e.i.r.p. 15.6 ~ 10 dBm [110.8 ~ 105.2 dBuV/m@3m] 5.875-5.925 GHz: e.i.r.p. 10 ~ -27 dBm [105.2 ~ 68.2dBuV/m@3m] Other un-restricted band: e.i.r.p. -27 dBm [68.2 dBuV/m@3m]
Note 1: Measurements may be performed at a distance other than the limit distance provided they are not performed in the near field and the emissions to be measured can be detected by the measurement equipment. When performing measurements at a distance other than that specified, the results shall be extrapolated to the specified distance using an extrapolation factor of 20 dB/decade (inverse of linear distance for field-strength measurements, inverse of linear distance-squared for power-density measurements).	

3.4.2 Measuring Instruments

Refer a test equipment and calibration data table in this test report.

3.4.3 Test Procedures

Test Method	
<ul style="list-style-type: none"> ▪ Measurements may be performed at a distance other than the limit distance provided they are not performed in the near field and the emissions to be measured can be detected by the measurement equipment. Measurements shall not be performed at a distance greater than 30 m for frequencies above 30 MHz, unless it can be further demonstrated that measurements at a distance of 30 m or less are impractical. When performing measurements at a distance other than that specified, the results shall be extrapolated to the specified distance using an extrapolation factor of 20 dB/decade (inverse of linear distance for field-strength measurements, inverse of linear distance-squared for power-density measurements). 	
<ul style="list-style-type: none"> ▪ The average emission levels shall be measured in [duty cycle \geq 98 or duty factor]. 	
<ul style="list-style-type: none"> ▪ For the transmitter unwanted emissions shall be measured using following options below: 	
	<ul style="list-style-type: none"> ▪ Refer as KDB 789033, clause G)2) for unwanted emissions into non-restricted bands.
	<ul style="list-style-type: none"> ▪ Refer as KDB 789033, clause G)1) for unwanted emissions into restricted bands.
	<input checked="" type="checkbox"/> Refer as KDB 789033, G)6) Method VB (ANSI C63.10, clause 4.1.4.2.3), Reduced VBW.
	<input checked="" type="checkbox"/> Refer as KDB 789033, clause G)5) (ANSI C63.10, clause 4.1.4.2.2), measurement procedure peak limit.
<ul style="list-style-type: none"> ▪ For radiated measurement. 	
	<ul style="list-style-type: none"> ▪ Refer as ANSI C63.10, clause 6.4 for radiated emissions below 30 MHz and test distance is 3m.
	<ul style="list-style-type: none"> ▪ Refer as ANSI C63.10, clause 6.5 for radiated emissions 30 MHz to 1 GHz and test distance is 3m.
	<ul style="list-style-type: none"> ▪ Refer as ANSI C63.10, clause 6.6 for radiated emissions above 1GHz.
<ul style="list-style-type: none"> ▪ The any unwanted emissions level shall not exceed the fundamental emission level. 	
<ul style="list-style-type: none"> ▪ All amplitude of spurious emissions that are attenuated by more than 20 dB below the permissible value has no need to be reported. 	

3.4.4 Test Setup

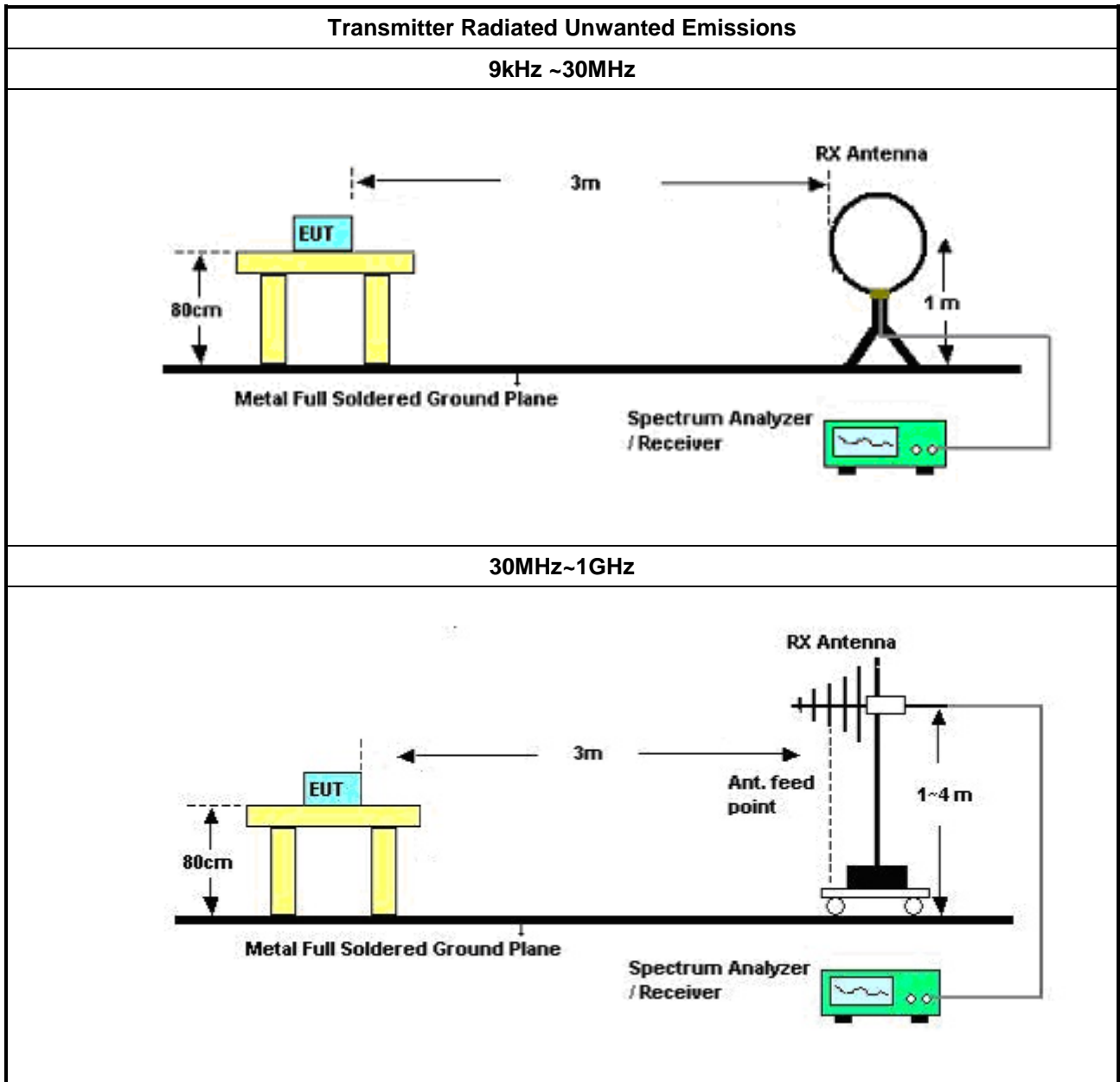

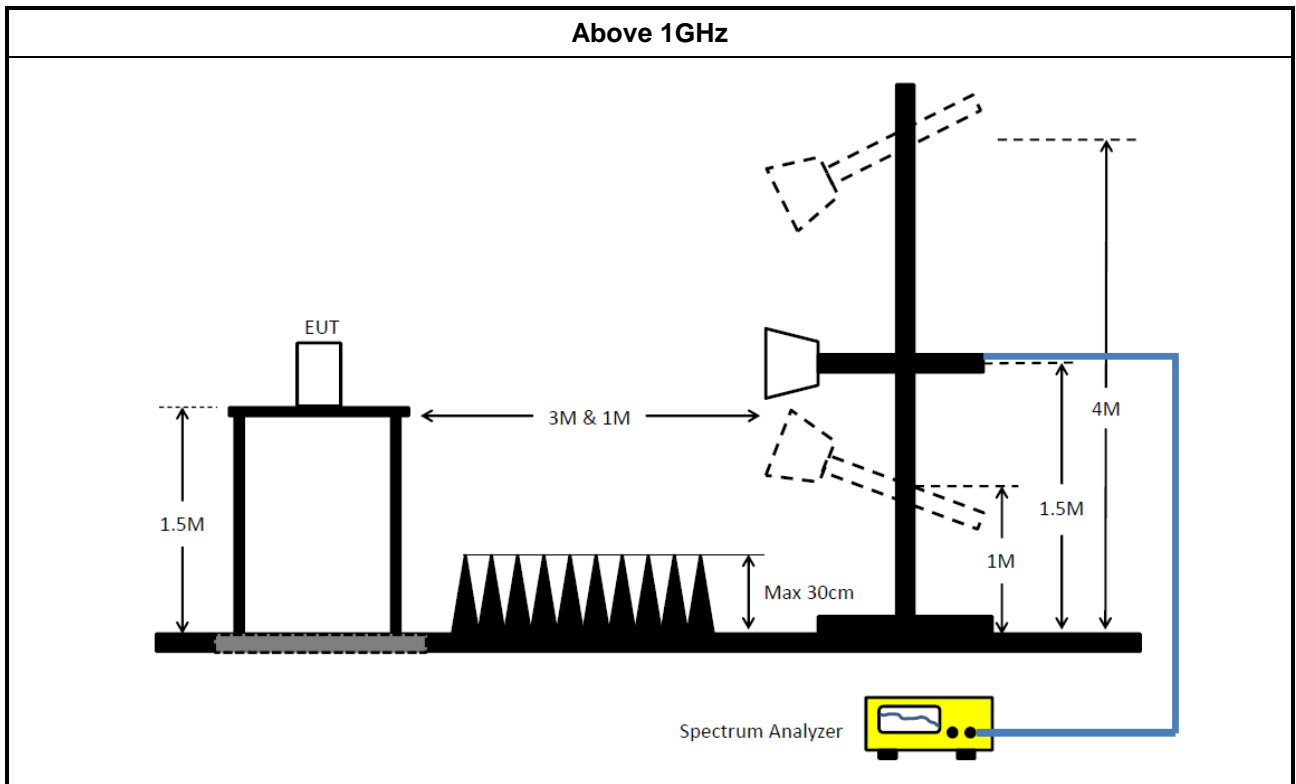

3.4.5 Transmitter Unwanted Emissions (Below 30MHz)

The amplitude of spurious emissions which are attenuated by more than 20dB below the permissible value has no need to be reported.

3.4.6 Test Result of Transmitter Unwanted Emissions

Refer as Appendix D

4 Test Equipment and Calibration Data

Instrument for Conducted Test

Instrument	Manufacturer	Model No.	Serial No.	Spec.	Calibration Date	Calibration Due Date
Spectrum Analyzer	R&S	FSV 40	101013	10Hz~40GHz	13/Mar/2019	12/Mar/2020
SMB100A Signal Generator	R&S	SMB100A03	181147	100kHz~40GHz	12/Nov/2018	10/Nov/2020
Power Sensor	Anritsu	MA2411B	0917017	300MHz ~ 40GHz	19/Feb/2019	18/Feb/2020
Power Meter	Anritsu	ML2495A	0949003	300MHz ~ 40GHz	19/Feb/2019	18/Feb/2020

Instrument for Radiated Test

Instrument	Manufacturer	Model No.	Serial No.	Spec.	Calibration Date	Calibration Due Date
3m Semi Anechoic Chamber	SIDT FRANKONIA	SAC-3M	03CH02-HY	30MHz ~ 1GHz 3m	29/Aug/2019	28/Aug/2020
3m Semi Anechoic Chamber	SIDT FRANKONIA	SAC-3M	03CH02-HY	1GHz ~ 18GHz 3m	29/Aug/2019	28/Aug/2020
Amplifier	Agilent	8447D	2944A11149	100kHz ~ 1.3GHz	02/Jul/2019	01/Jul/2020
Microwave Preamplifier	Agilent	8449B	3008A02373	1GHz ~ 26.5GHz	16/Oct/2019	15/Oct/2020
Signal Analyzer	R&S	FSV40	101500	10Hz ~ 40GHz	15/Aug/2019	14/Aug/2020
EMI Test Receiver	R&S	ESR3	102052	9kHz ~ 3.6GHz	09/Apr/2019	08/Apr/2020
RF Cable-R03m	Jye Bao	RG142	CB017	9kHz ~ 1GHz	26/Mar/2019	25/Mar/2020
RF Cable-high 6m	SUHNER	SUCOFLEX104	10567868 / SN805193/4	1GHz~40GHz	09/Apr/2019	08/Apr/2020
RF Cable-high 7m	SUHNER	SUCOFLEX104	10567868 / SN805192/4	1GHz~40GHz	09/Apr/2019	08/Apr/2020
Bilog Antenna & 5dB Attenuator	SCHAFFNER / MTJ	CBL 6112D / MTJ6102-05	2678 / 001	30MHz ~ 2GHz	06/Jul/2019	05/Jul/2020
Broadband Horn Antenna	SCHWARZBECK	BBHA 9170	BBHA 9170221	15GHz ~ 40GHz	22/Mar/2019	21/Mar/2020
Preamplifier	MITEQ	TTA1840-35-H G	1864481	18GHz ~ 40GHz	05/Aug/2019	04/Aug/2020
Double Ridged Guide Horn Antenna	SCHWARZBECK	BBHA 9120 D	BBHA 9120 D 01543	1GHz ~ 18GHz	03/Jun/2019	02/Jun/2020



Summary

Mode	Max-N dB (Hz)	Max-OBW (Hz)	ITU-Code	Min-N dB (Hz)	Min-OBW (Hz)
5.25-5.35GHz	-	-	-	-	-
802.11a_Nss1,(6Mbps)_1TX	37.77M	19.55M	19M5D1D	37.17M	17.391M
802.11ac VHT20_Nss1,(MCS0)_1TX	37.32M	18.801M	18M8D1D	29.37M	18.111M
802.11ac VHT40_Nss1,(MCS0)_1TX	77.28M	39.22M	39M2D1D	49.92M	36.582M
802.11ac VHT80_Nss1,(MCS0)_1TX	108M	75.922M	75M9D1D	108M	75.922M
802.11ax HEW20_Nss1,(MCS0)_1TX	41.07M	19.79M	19M8D1D	26.7M	18.081M
802.11ax HEW40_Nss1,(MCS0)_1TX	82.32M	38.741M	38M7D1D	52.14M	37.721M
802.11ax HEW80_Nss1,(MCS0)_1TX	84.72M	77.241M	77M2D1D	84.72M	77.241M
5.47-5.725GHz	-	-	-	-	-
802.11a_Nss1,(6Mbps)_1TX	37.38M	18.951M	19M0D1D	22.77M	14.71M
802.11ac VHT20_Nss1,(MCS0)_1TX	36.66M	19.13M	19M1D1D	21.66M	14.43M
802.11ac VHT40_Nss1,(MCS0)_1TX	85.74M	39.52M	39M5D1D	40.26M	33.883M
802.11ac VHT80_Nss1,(MCS0)_1TX	145.2M	77.361M	77M4D1D	85.68M	73.433M
802.11ax HEW20_Nss1,(MCS0)_1TX	40.95M	19.73M	19M7D1D	22.35M	14.938M
802.11ax HEW40_Nss1,(MCS0)_1TX	74.4M	39.16M	39M2D1D	40.14M	34.783M
802.11ax HEW80_Nss1,(MCS0)_1TX	145.44M	78.441M	78M4D1D	81.96M	74.363M
5.725-5.85GHz	-	-	-	-	-
802.11a_Nss1,(6Mbps)_1TX	3.21M	9.865M	9M87D1D	3.21M	9.865M
802.11ac VHT20_Nss1,(MCS0)_1TX	3.825M	9.01M	9M01D1D	3.825M	9.01M
802.11ac VHT40_Nss1,(MCS0)_1TX	3.225M	20.39M	20M4D1D	3.225M	20.39M
802.11ac VHT80_Nss1,(MCS0)_1TX	3.18M	25.832M	25M8D1D	3.18M	25.832M
802.11ax HEW20_Nss1,(MCS0)_1TX	4.5M	10.975M	11M0D1D	4.5M	10.975M
802.11ax HEW40_Nss1,(MCS0)_1TX	3.78M	21.889M	21M9D1D	3.78M	21.889M
802.11ax HEW80_Nss1,(MCS0)_1TX	3.855M	27.181M	27M2D1D	3.855M	27.181M

Max-N dB = Maximum 6dB down bandwidth for 5.725-5.85GHz band / Maximum 26dB down bandwidth for other band;

Max-OBW = Maximum 99% occupied bandwidth;

Min-N dB = Minimum 6dB down bandwidth for 5.725-5.85GHz band / Maximum 26dB down bandwidth for other band;

Min-OBW = Minimum 99% occupied bandwidth;



Result

Mode	Result	Limit (Hz)	Port 1-N dB (Hz)	Port 1-OBW (Hz)
802.11a_Nss1,(6Mbps)_1TX	-	-	-	-
5260MHz	Pass	Inf	37.77M	19.07M
5300MHz	Pass	Inf	37.56M	19.55M
5320MHz	Pass	Inf	37.17M	17.391M
5500MHz	Pass	Inf	34.08M	17.181M
5580MHz	Pass	Inf	37.38M	18.951M
5700MHz	Pass	Inf	22.77M	16.882M
5720MHz Straddle 5.47-5.725GHz	Pass	Inf	23.345M	14.71M
5720MHz Straddle 5.725-5.85GHz	Pass	500k	3.21M	9.865M
802.11ac VHT20_Nss1,(MCS0)_1TX	-	-	-	-
5260MHz	Pass	Inf	36.54M	18.771M
5300MHz	Pass	Inf	37.32M	18.801M
5320MHz	Pass	Inf	29.37M	18.111M
5500MHz	Pass	Inf	25.65M	17.961M
5580MHz	Pass	Inf	36.66M	19.13M
5700MHz	Pass	Inf	21.66M	17.901M
5720MHz Straddle 5.47-5.725GHz	Pass	Inf	23.555M	14.43M
5720MHz Straddle 5.725-5.85GHz	Pass	500k	3.825M	9.01M
802.11ac VHT40_Nss1,(MCS0)_1TX	-	-	-	-
5270MHz	Pass	Inf	77.28M	39.22M
5310MHz	Pass	Inf	49.92M	36.582M
5510MHz	Pass	Inf	40.26M	36.462M
5550MHz	Pass	Inf	75.24M	37.421M
5670MHz	Pass	Inf	85.74M	39.52M
5710MHz Straddle 5.47-5.725GHz	Pass	Inf	56.813M	33.883M
5710MHz Straddle 5.725-5.85GHz	Pass	500k	3.225M	20.39M
802.11ac VHT80_Nss1,(MCS0)_1TX	-	-	-	-
5290MHz	Pass	Inf	108M	75.922M
5530MHz	Pass	Inf	85.68M	76.042M
5610MHz	Pass	Inf	145.2M	77.361M
5690MHz Straddle 5.47-5.725GHz	Pass	Inf	109.353M	73.433M
5690MHz Straddle 5.725-5.85GHz	Pass	500k	3.18M	25.832M
802.11ax HEW20_Nss1,(MCS0)_1TX	-	-	-	-
5260MHz	Pass	Inf	41.07M	19.79M
5300MHz	Pass	Inf	41.04M	19.55M
5320MHz	Pass	Inf	26.7M	18.081M
5500MHz	Pass	Inf	25.26M	19.1M
5580MHz	Pass	Inf	40.95M	19.73M
5700MHz	Pass	Inf	22.35M	19.04M
5720MHz Straddle 5.47-5.725GHz	Pass	Inf	25.358M	14.938M
5720MHz Straddle 5.725-5.85GHz	Pass	500k	4.5M	10.975M
802.11ax HEW40_Nss1,(MCS0)_1TX	-	-	-	-
5270MHz	Pass	Inf	82.32M	38.741M
5310MHz	Pass	Inf	52.14M	37.721M



Mode	Result	Limit (Hz)	Port 1-N dB (Hz)	Port 1-OBW (Hz)
5510MHz	Pass	Inf	40.14M	37.601M
5550MHz	Pass	Inf	74.1M	39.16M
5670MHz	Pass	Inf	74.4M	39.04M
5710MHz Straddle 5.47-5.725GHz	Pass	Inf	58.275M	34.783M
5710MHz Straddle 5.725-5.85GHz	Pass	500k	3.78M	21.889M
802.11ax HEW80_Nss1,(MCS0)_1TX	-	-	-	-
5290MHz	Pass	Inf	84.72M	77.241M
5530MHz	Pass	Inf	81.96M	77.241M
5610MHz	Pass	Inf	145.44M	78.441M
5690MHz Straddle 5.47-5.725GHz	Pass	Inf	118.653M	74.363M
5690MHz Straddle 5.725-5.85GHz	Pass	500k	3.855M	27.181M

Port X-N dB = Port X 6dB down bandwidth for 5.725-5.85GHz band / 26dB down bandwidth for other band
Port X-OBW = Port X 99% occupied bandwidth;

802.11a_Nss1,(6Mbps)_1TX

EBW

5260MHz

06/01/2020

CF
5.26GHz
Span
60MHz
RBW
200kHz
VBW
1MHz
Sweep Time
100ms
Detector Type
Peak
Port1

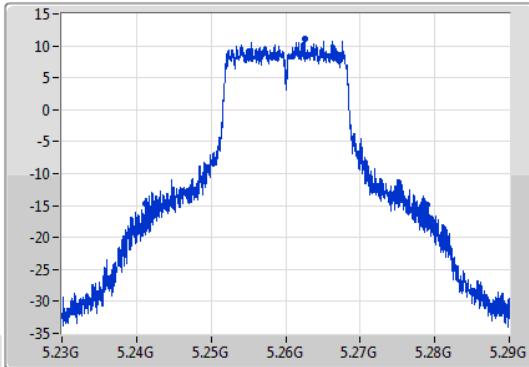

CF
5.26GHz
Span
60MHz
RBW
200kHz
VBW
1MHz
Sweep Time
100ms
Detector Type
Peak

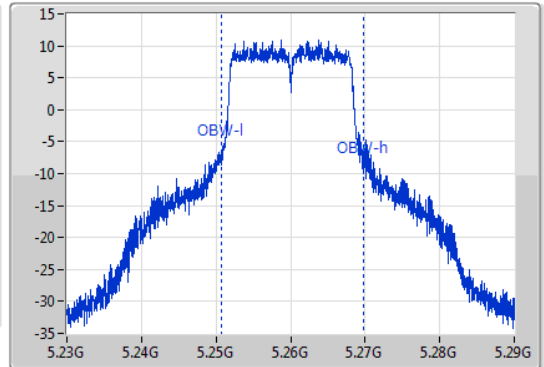

26dB(Hz)	Fl-26dB(Hz)	Fh-26dB(Hz)	OBW(Hz)	Fl-OBW(Hz)	Fh-OBW(Hz)	Limit(Hz)	Port
37.77M	5.24122G	5.27899G	19.07M	5.250645G	5.269715G	Inf	1

802.11a_Nss1,(6Mbps)_1TX

EBW

5300MHz

06/01/2020

CF
5.3GHz
Span
60MHz
RBW
200kHz
VBW
1MHz
Sweep Time
100ms
Detector Type
Peak
Port1

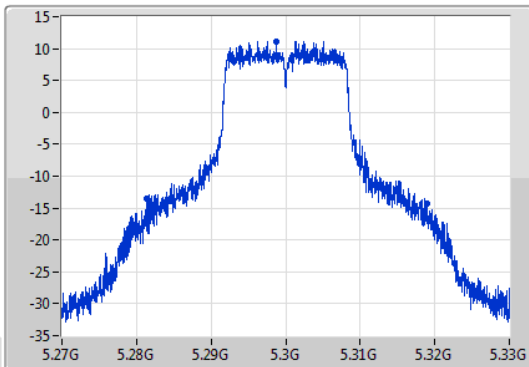

CF
5.3GHz
Span
60MHz
RBW
200kHz
VBW
1MHz
Sweep Time
100ms
Detector Type
Peak

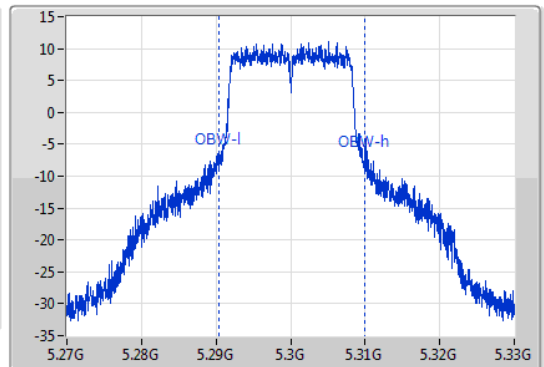

26dB(Hz)	Fl-26dB(Hz)	Fh-26dB(Hz)	OBW(Hz)	Fl-OBW(Hz)	Fh-OBW(Hz)	Limit(Hz)	Port
37.56M	5.28137G	5.31893G	19.55M	5.290345G	5.309895G	Inf	1

802.11a_Nss1,(6Mbps)_1TX

EBW

5320MHz

06/01/2020

CF
5.32GHz
Span
60MHz
RBW
200kHz
VBW
1MHz
Sweep Time
100ms
Detector Type
Peak
Port 1

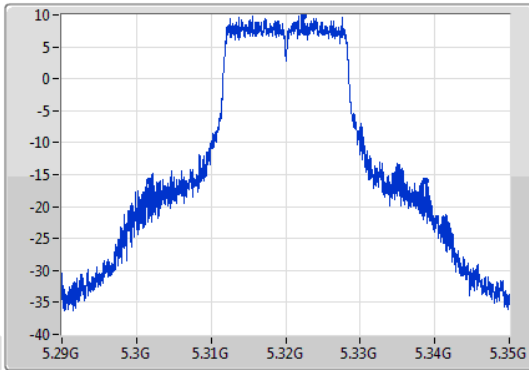

CF
5.32GHz
Span
60MHz
RBW
200kHz
VBW
1MHz
Sweep Time
100ms
Detector Type
Peak

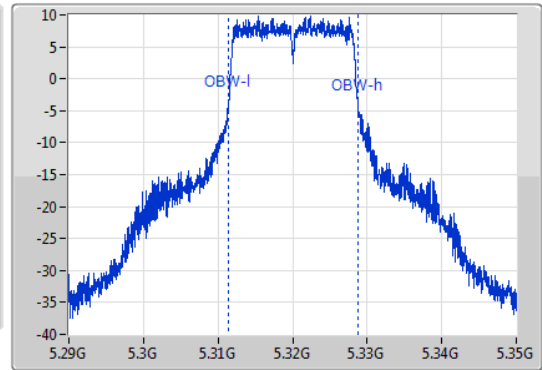

26dB(Hz)	Fl-26dB(Hz)	Fh-26dB(Hz)	OBW(Hz)	Fl-OBW(Hz)	Fh-OBW(Hz)	Limit(Hz)	Port
37.17M	5.30164G	5.33881G	17.391M	5.311424G	5.328816G	Inf	1

802.11a_Nss1,(6Mbps)_1TX

EBW

5500MHz

06/01/2020

CF
5.5GHz
Span
60MHz
RBW
200kHz
VBW
1MHz
Sweep Time
100ms
Detector Type
Peak
Port 1

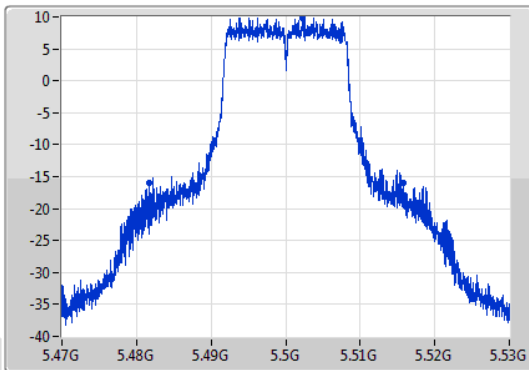

CF
5.5GHz
Span
60MHz
RBW
200kHz
VBW
1MHz
Sweep Time
100ms
Detector Type
Peak

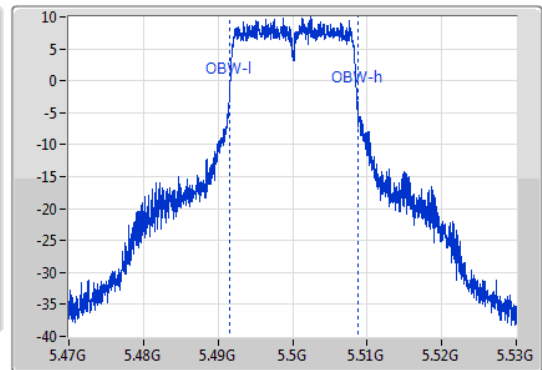

26dB(Hz)	Fl-26dB(Hz)	Fh-26dB(Hz)	OBW(Hz)	Fl-OBW(Hz)	Fh-OBW(Hz)	Limit(Hz)	Port
34.08M	5.4817G	5.51578G	17.181M	5.491514G	5.508696G	Inf	1

802.11a_Nss1,(6Mbps)_1TX

EBW

5580MHz

06/01/2020

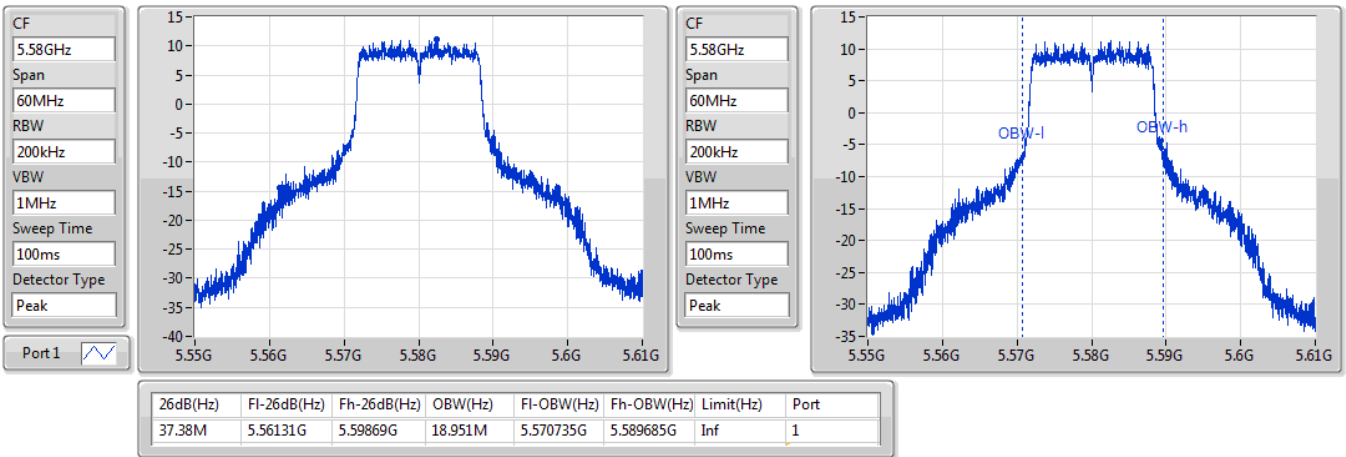

802.11a_Nss1,(6Mbps)_1TX

EBW

5700MHz

06/01/2020

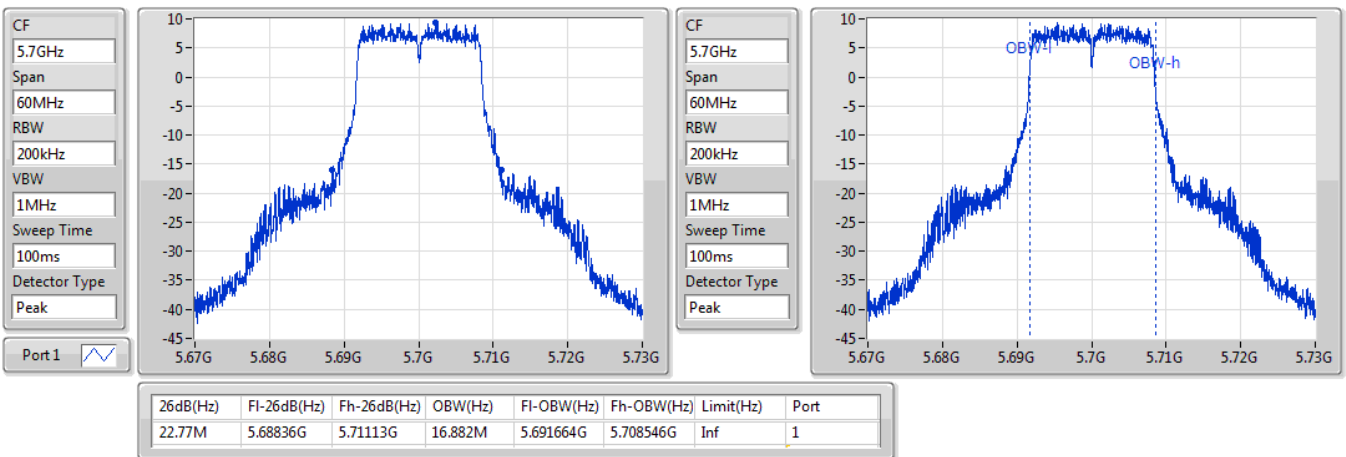

802.11a_Nss1,(6Mbps)_1TX

EBW

5720MHz Straddle 5.47-5.725GHz

06/01/2020

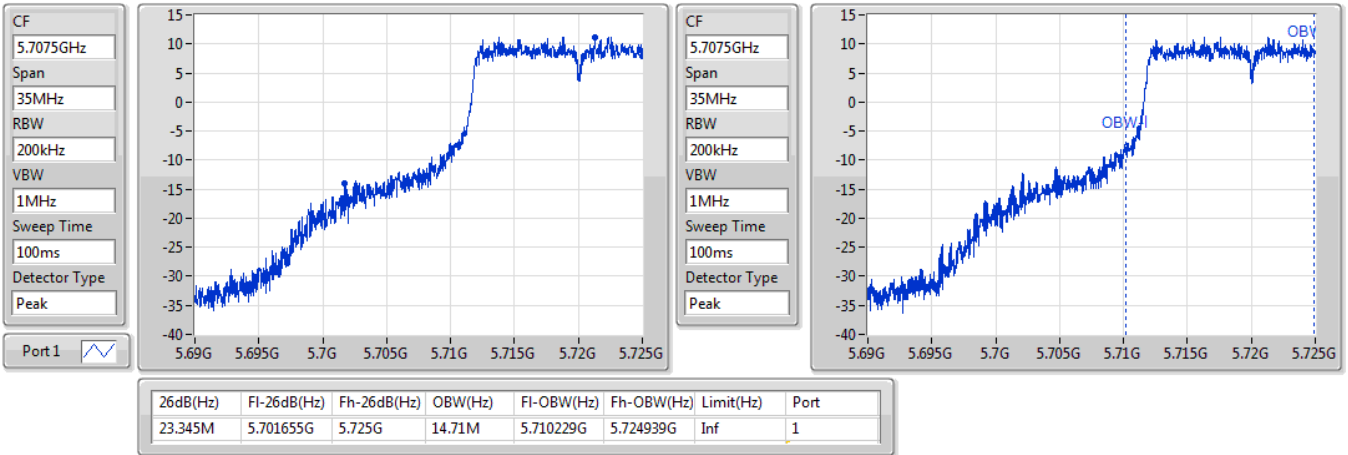

802.11a_Nss1,(6Mbps)_1TX

EBW

5720MHz Straddle 5.725-5.85GHz

06/01/2020

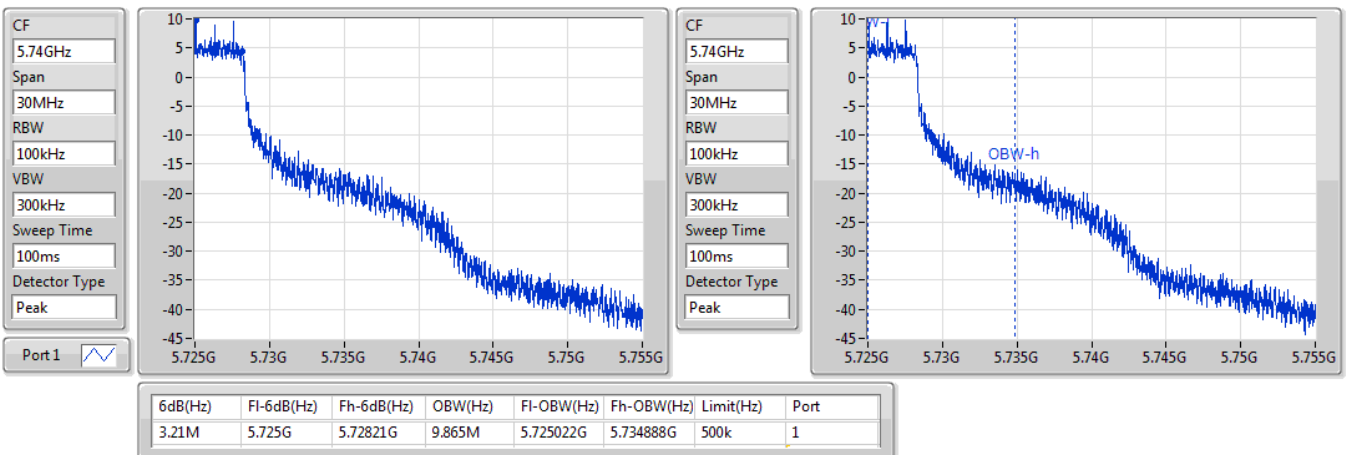

802.11ac VHT20_Nss1,(MCS0)_1TX

EBW

5260MHz

06/01/2020

CF
5.26GHz
Span
60MHz
RBW
200kHz
VBW
1MHz
Sweep Time
100ms
Detector Type
Peak

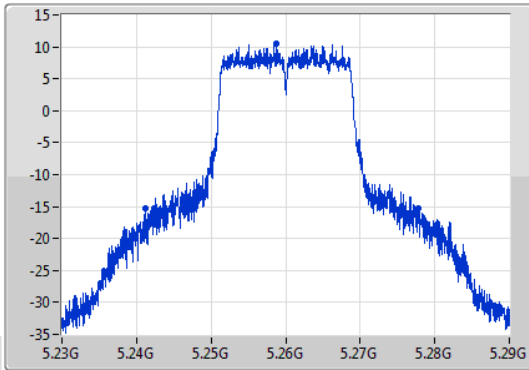

CF
5.26GHz
Span
60MHz
RBW
200kHz
VBW
1MHz
Sweep Time
100ms
Detector Type
Peak

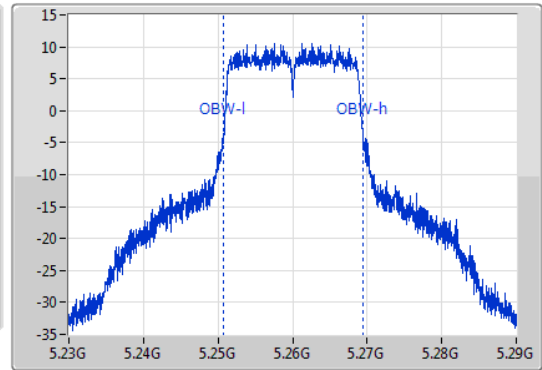

26dB(Hz)	Fl-26dB(Hz)	Fh-26dB(Hz)	OBW(Hz)	Fl-OBW(Hz)	Fh-OBW(Hz)	Limit(Hz)	Port
36.54M	5.24122G	5.27776G	18.771M	5.250705G	5.269475G	Inf	1

802.11ac VHT20_Nss1,(MCS0)_1TX

EBW

5300MHz

06/01/2020

CF
5.3GHz
Span
60MHz
RBW
200kHz
VBW
1MHz
Sweep Time
100ms
Detector Type
Peak

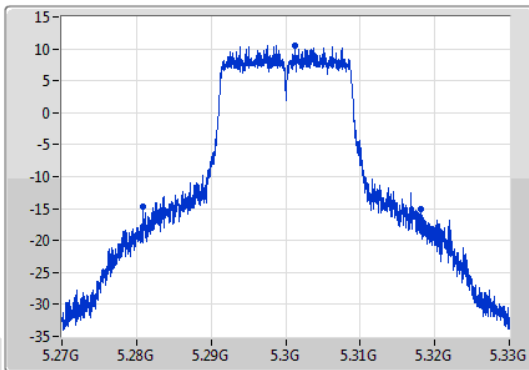

CF
5.3GHz
Span
60MHz
RBW
200kHz
VBW
1MHz
Sweep Time
100ms
Detector Type
Peak

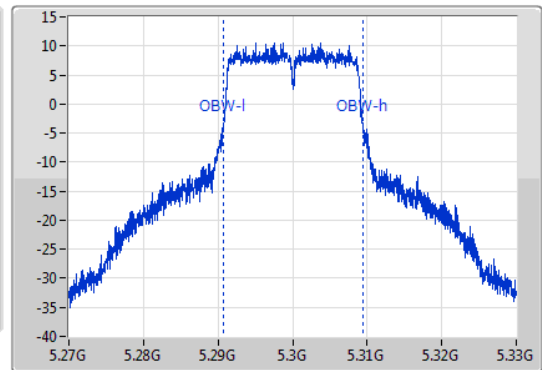

26dB(Hz)	Fl-26dB(Hz)	Fh-26dB(Hz)	OBW(Hz)	Fl-OBW(Hz)	Fh-OBW(Hz)	Limit(Hz)	Port
37.32M	5.28086G	5.31818G	18.801M	5.290675G	5.309475G	Inf	1

802.11ac VHT20_Nss1,(MCS0)_1TX

EBW

5320MHz

06/01/2020

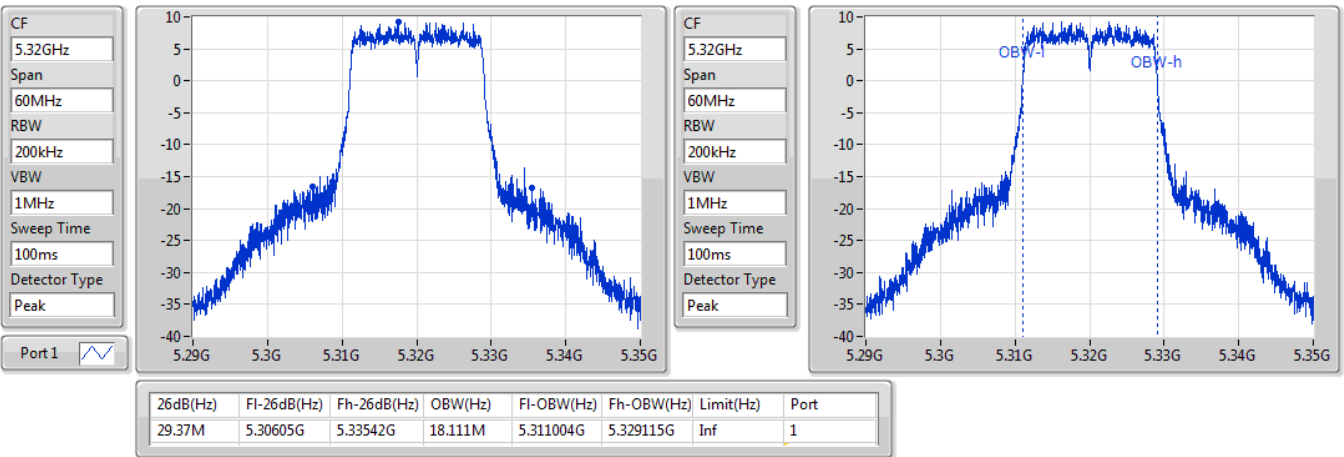

802.11ac VHT20_Nss1,(MCS0)_1TX

EBW

5500MHz

06/01/2020

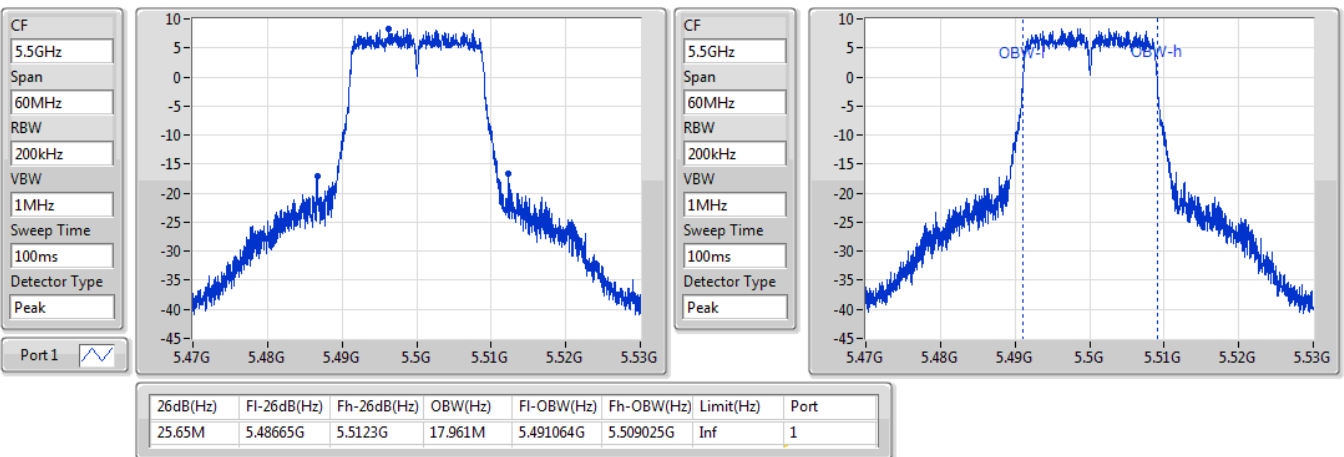

802.11ac VHT20_Nss1,(MCS0)_1TX

EBW

5580MHz

06/01/2020

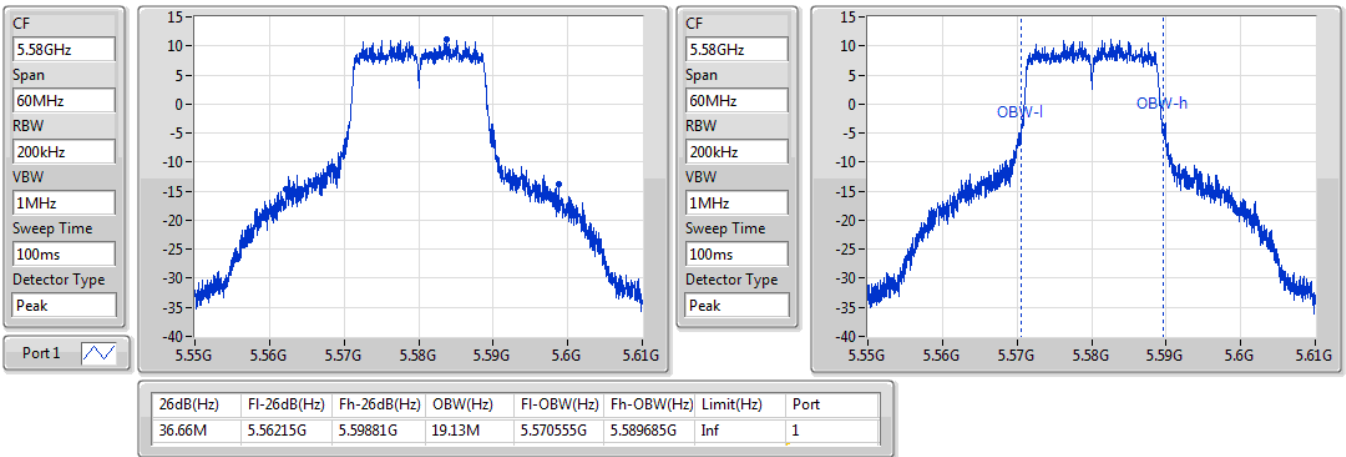

802.11ac VHT20_Nss1,(MCS0)_1TX

EBW

5700MHz

06/01/2020

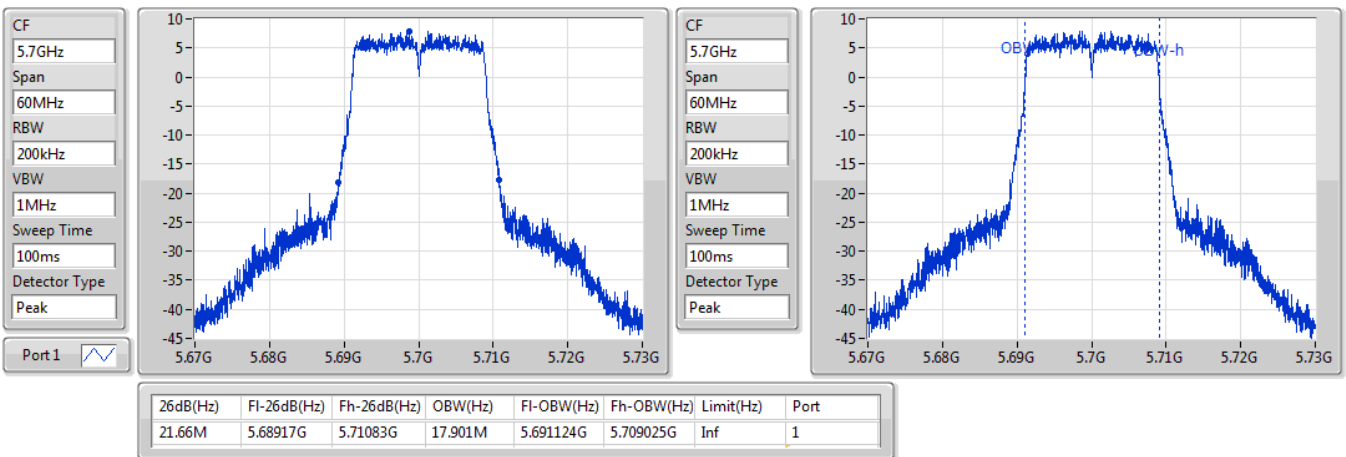

802.11ac VHT20_Nss1,(MCS0)_1TX
5720MHz Straddle 5.47-5.725GHz

EBW

06/01/2020

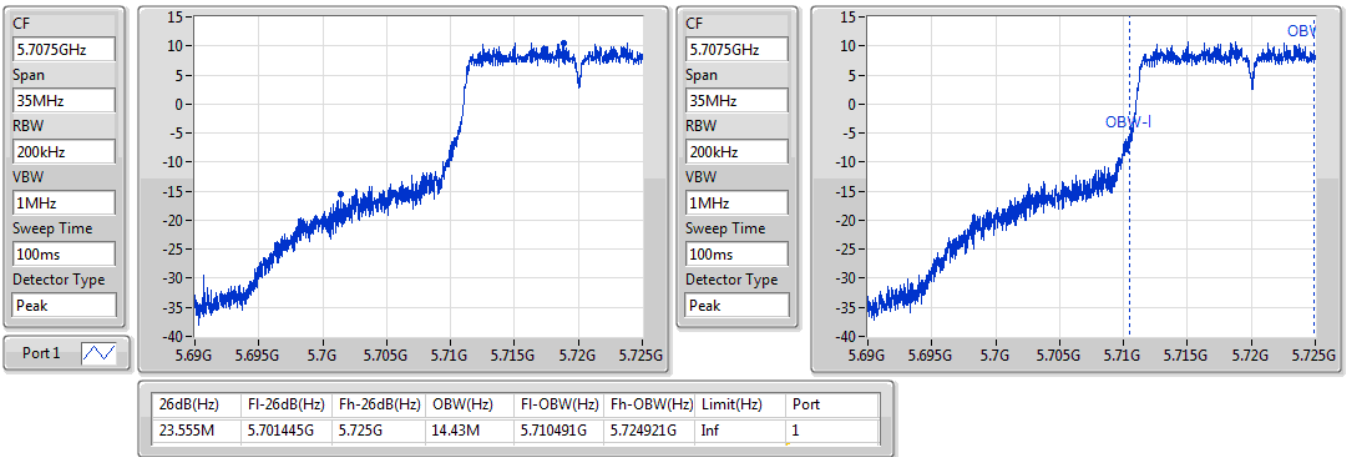

802.11ac VHT20_Nss1,(MCS0)_1TX
5720MHz Straddle 5.725-5.85GHz

EBW

06/01/2020

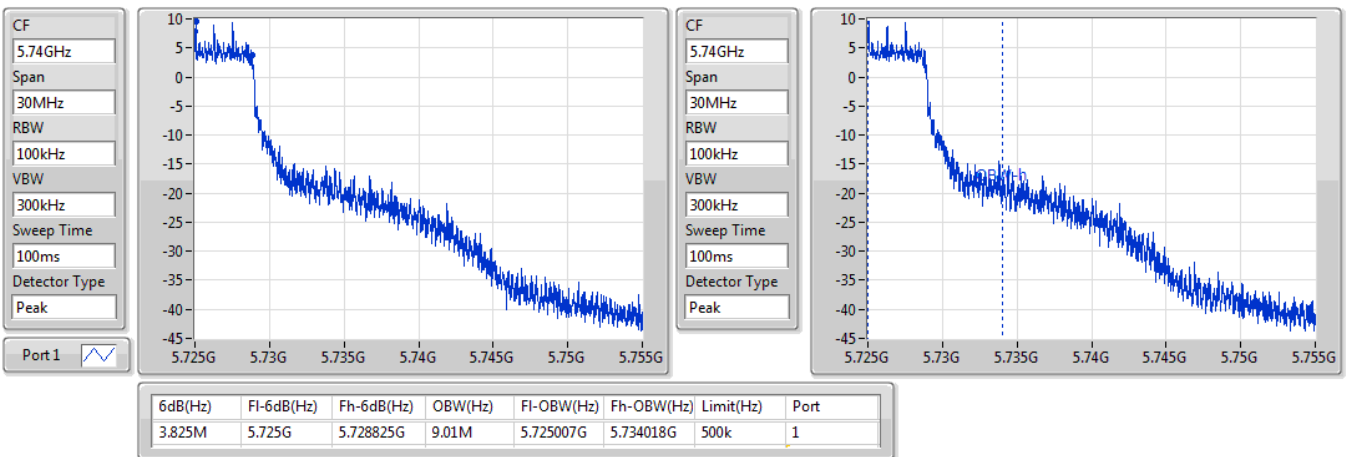

802.11ac VHT40_Nss1,(MCS0)_1TX

EBW

5270MHz

06/01/2020

CF
5.27GHz
Span
120MHz
RBW
500kHz
VBW
2MHz
Sweep Time
100ms
Detector Type
Peak
Port 1

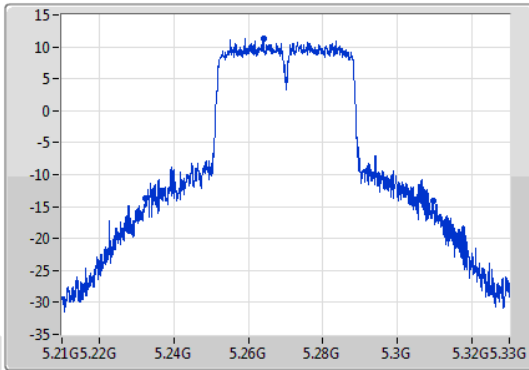

CF
5.27GHz
Span
120MHz
RBW
500kHz
VBW
2MHz
Sweep Time
100ms
Detector Type
Peak

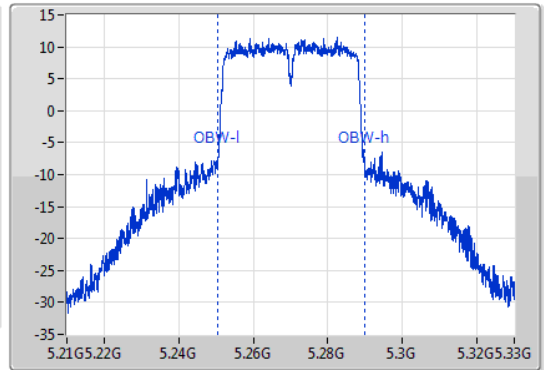

26dB(Hz)	Fl-26dB(Hz)	Fh-26dB(Hz)	OBW(Hz)	Fl-OBW(Hz)	Fh-OBW(Hz)	Limit(Hz)	Port
77.28M	5.23244G	5.30972G	39.22M	5.25051G	5.28973G	Inf	1

802.11ac VHT40_Nss1,(MCS0)_1TX

EBW

5310MHz

06/01/2020

CF
5.31GHz
Span
120MHz
RBW
500kHz
VBW
2MHz
Sweep Time
100ms
Detector Type
Peak
Port 1

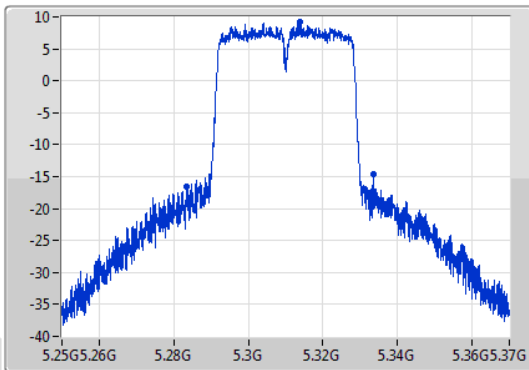

CF
5.31GHz
Span
120MHz
RBW
500kHz
VBW
2MHz
Sweep Time
100ms
Detector Type
Peak

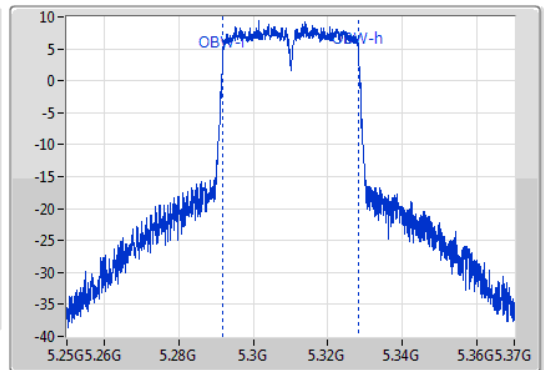

26dB(Hz)	Fl-26dB(Hz)	Fh-26dB(Hz)	OBW(Hz)	Fl-OBW(Hz)	Fh-OBW(Hz)	Limit(Hz)	Port
49.92M	5.28348G	5.3334G	36.582M	5.291769G	5.328351G	Inf	1

802.11ac VHT40_Nss1,(MCS0)_1TX

EBW

5510MHz

06/01/2020

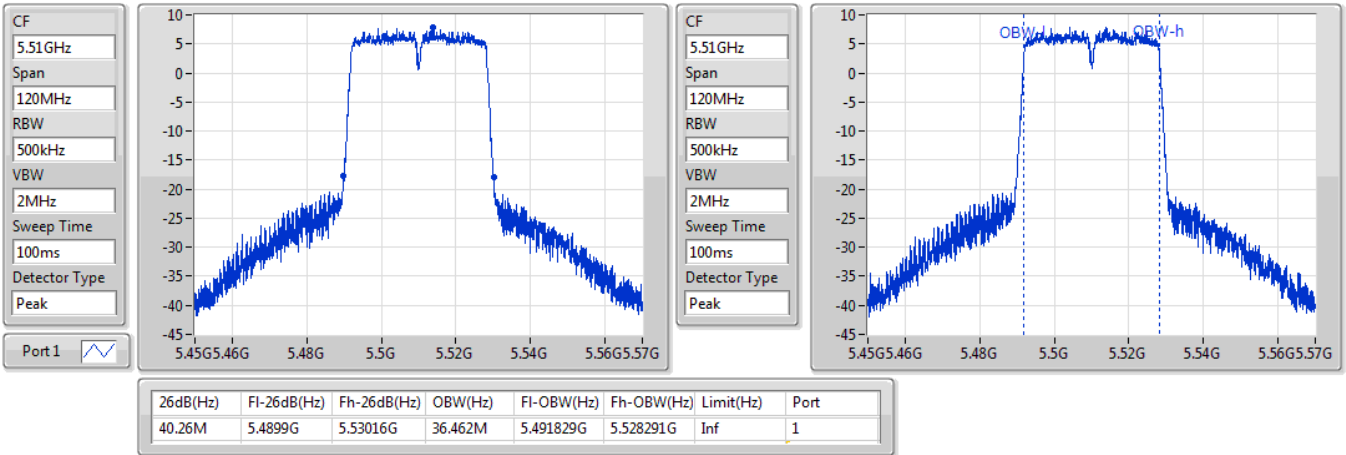

802.11ac VHT40_Nss1,(MCS0)_1TX

EBW

5550MHz

06/01/2020

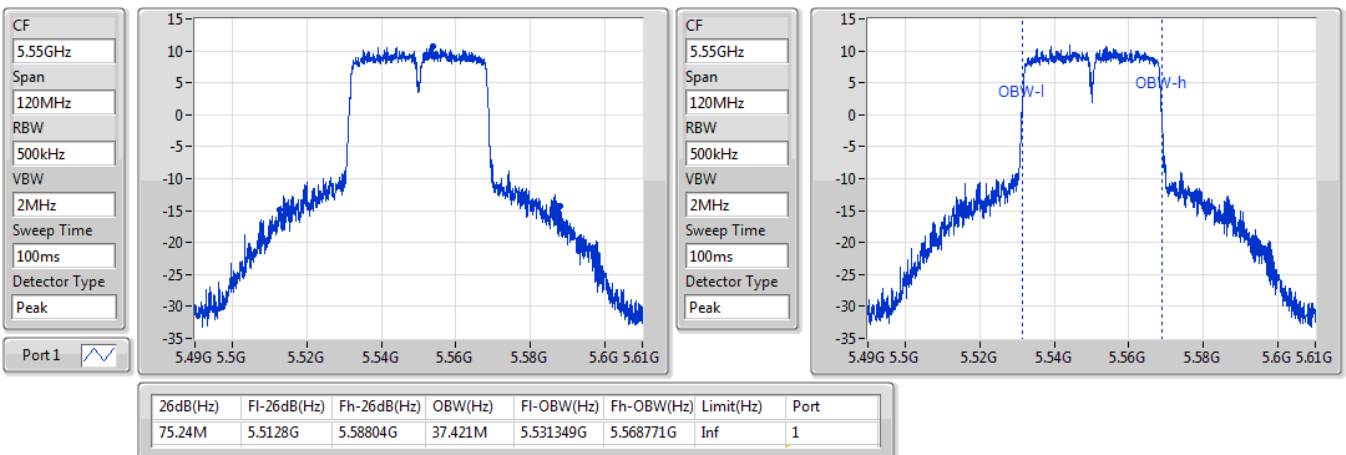

802.11ac VHT40_Nss1,(MCS0)_1TX

EBW

5670MHz

06/01/2020

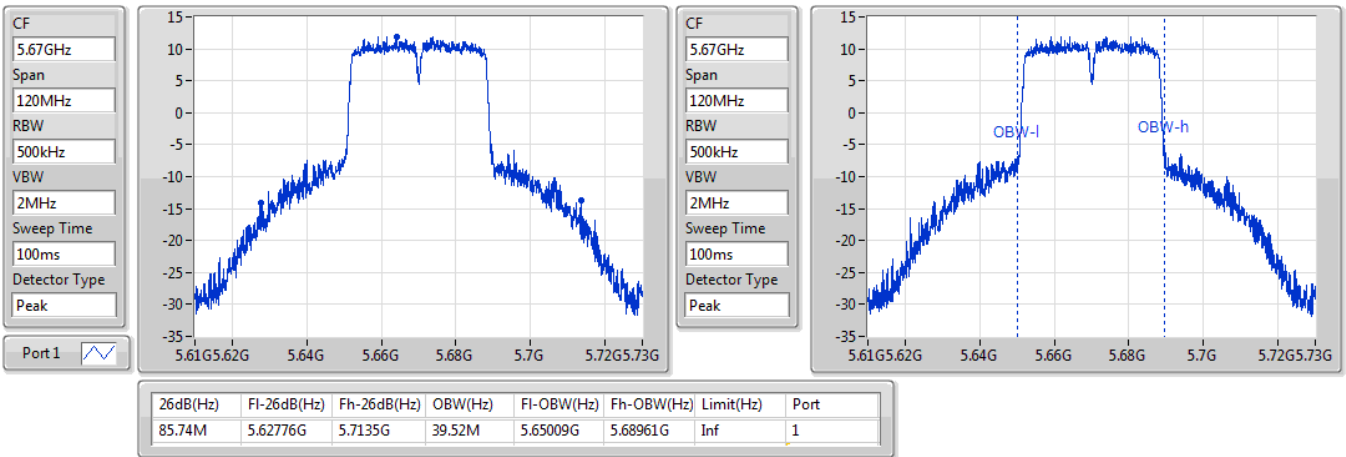

802.11ac VHT40_Nss1,(MCS0)_1TX

EBW

5710MHz Straddle 5.47-5.725GHz

06/01/2020

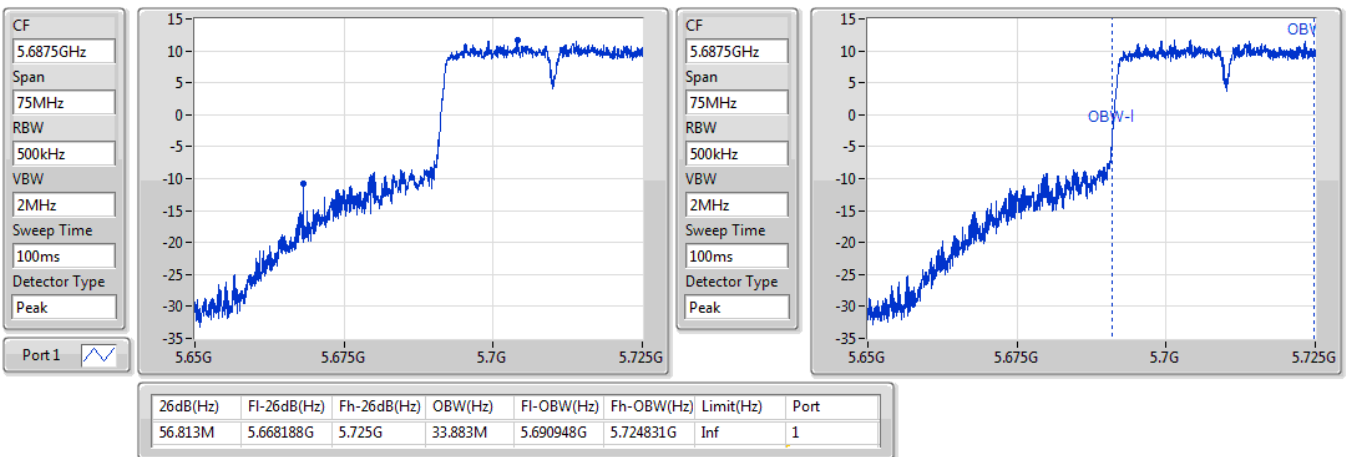

802.11ac VHT40_Nss1,(MCS0)_1TX
5710MHz Straddle 5.725-5.85GHz

EBW

06/01/2020

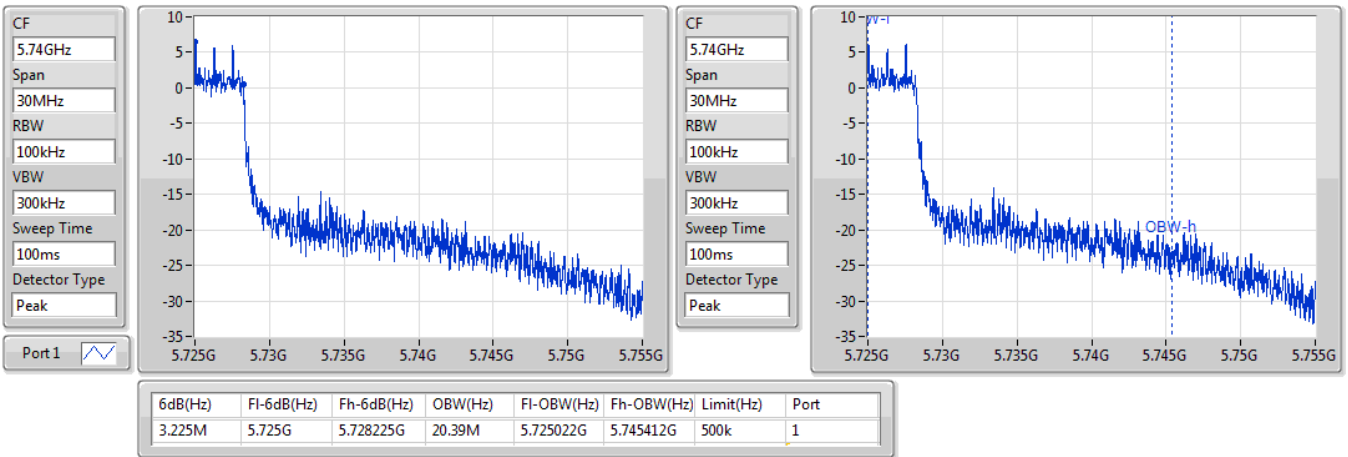

802.11ac VHT80_Nss1,(MCS0)_1TX
5290MHz

EBW

06/01/2020

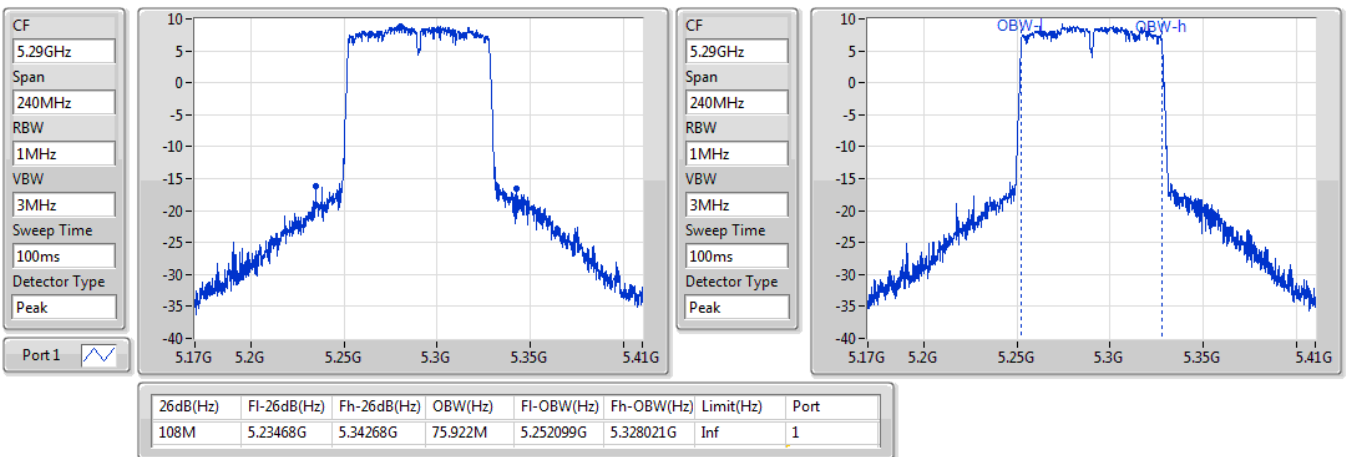

802.11ac VHT80_Nss1,(MCS0)_1TX

EBW

5530MHz

06/01/2020

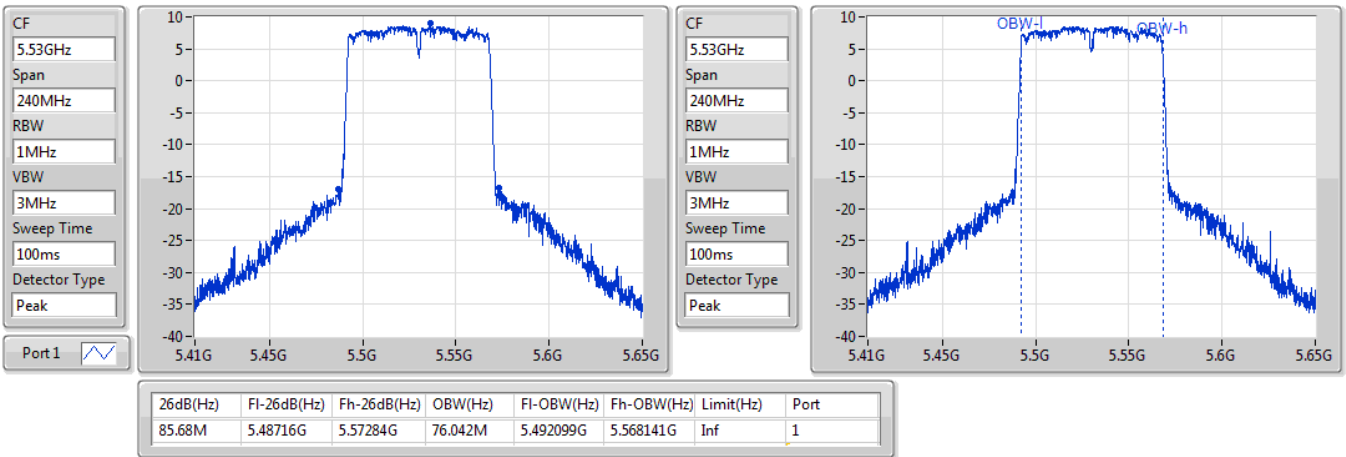

802.11ac VHT80_Nss1,(MCS0)_1TX

EBW

5610MHz

06/01/2020

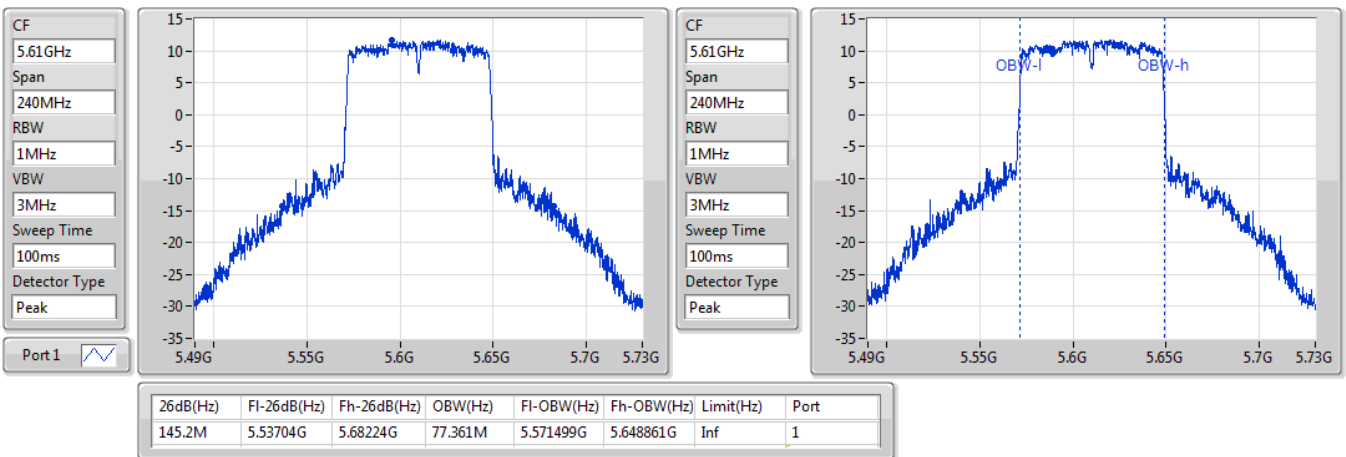

802.11ac VHT80_Nss1,(MCS0)_1TX

EBW

5690MHz Straddle 5.47-5.725GHz

06/01/2020

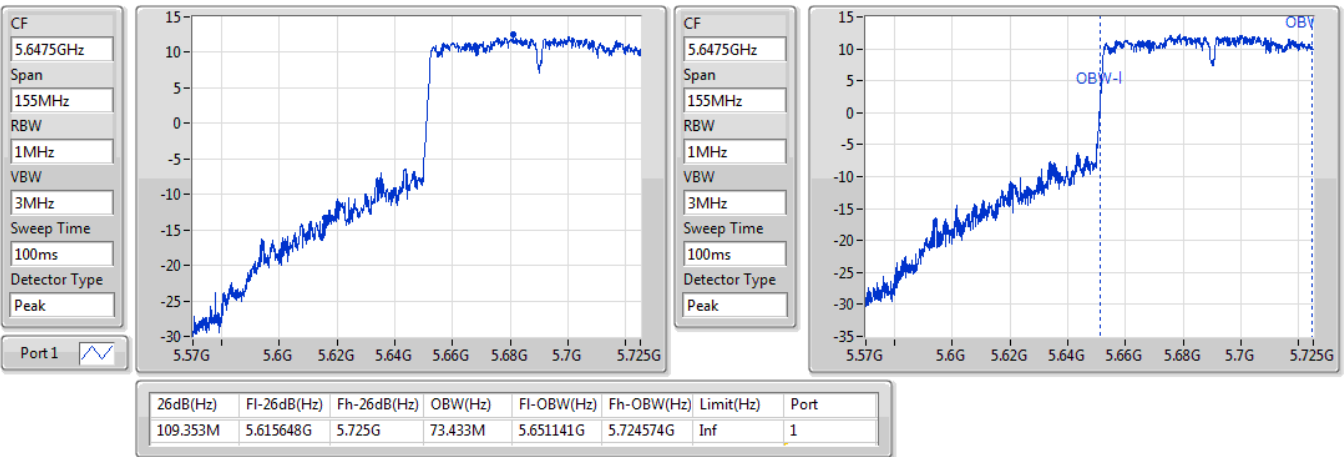

802.11ac VHT80_Nss1,(MCS0)_1TX

EBW

5690MHz Straddle 5.725-5.85GHz

06/01/2020

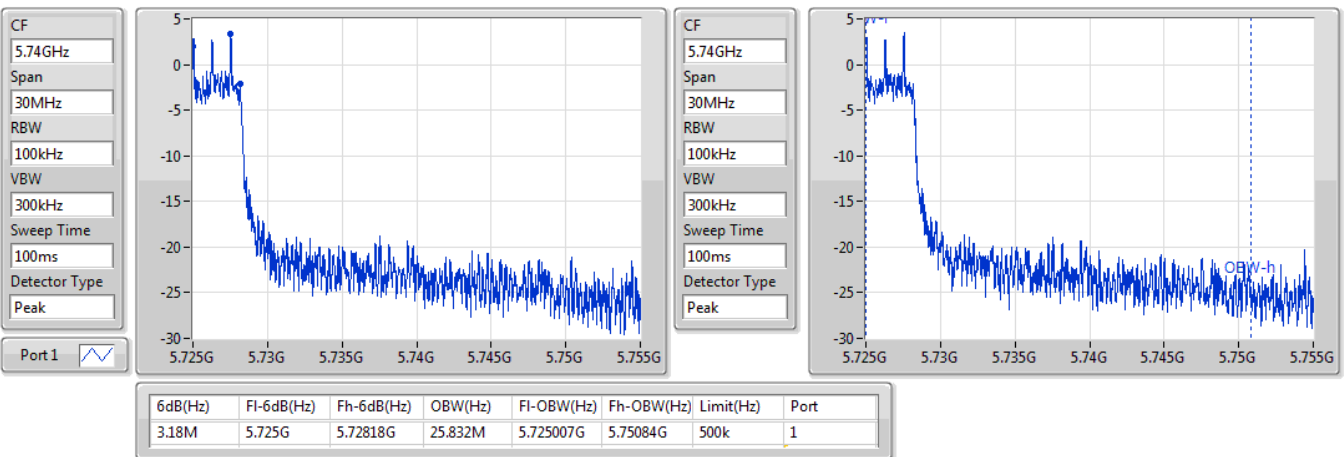

802.11ax HEW20_Nss1,(MCS0)_1TX

EBW

5260MHz

06/01/2020

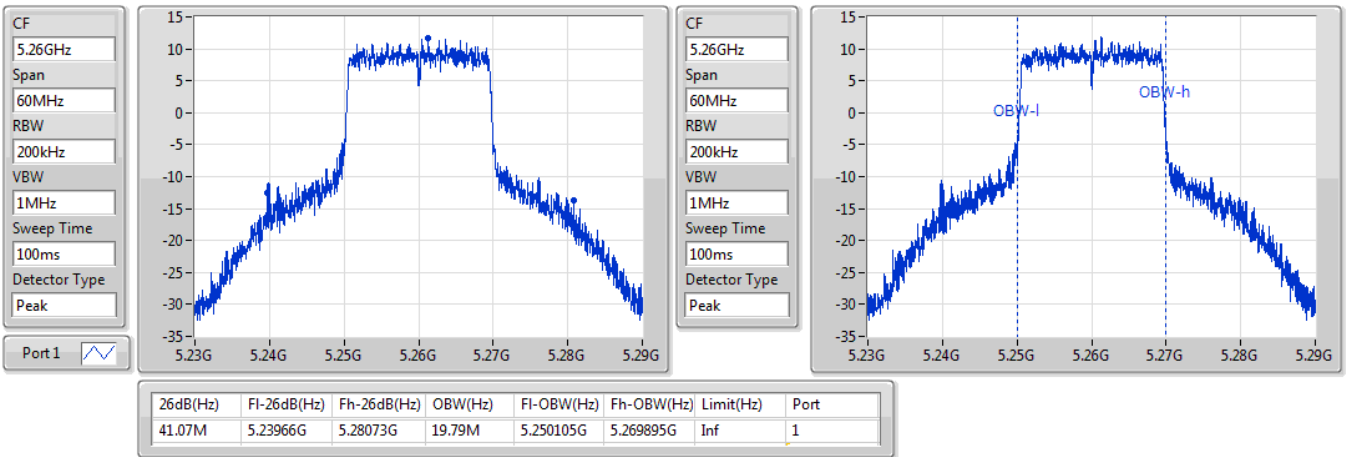

802.11ax HEW20_Nss1,(MCS0)_1TX

EBW

5300MHz

06/01/2020

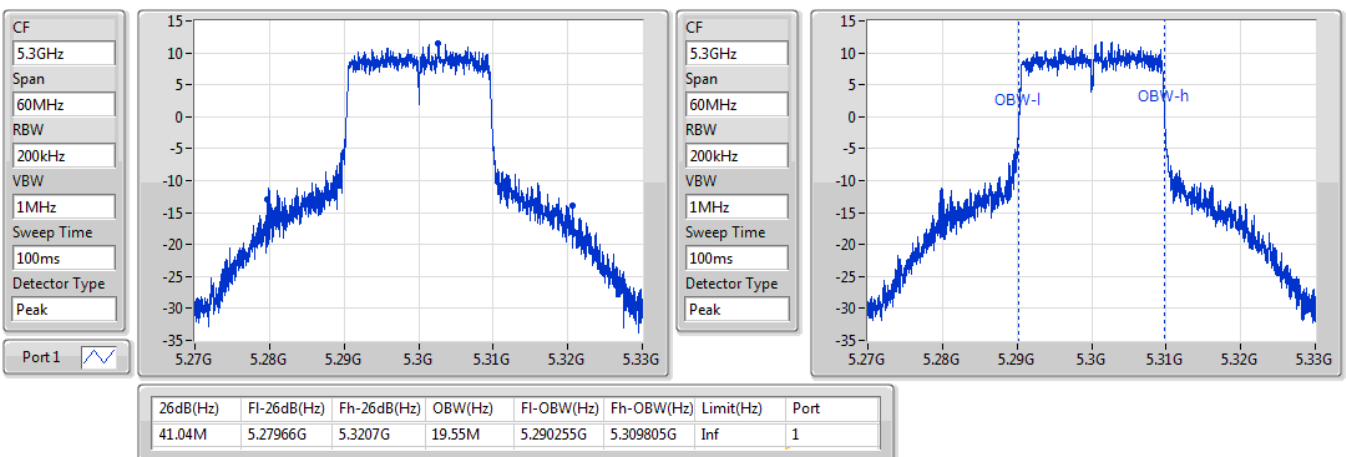

802.11ax HEW20_Nss1,(MCS0)_1TX

EBW

5320MHz

06/01/2020

CF
5.32GHz
Span
60MHz
RBW
200kHz
VBW
1MHz
Sweep Time
100ms
Detector Type
Peak
Port 1

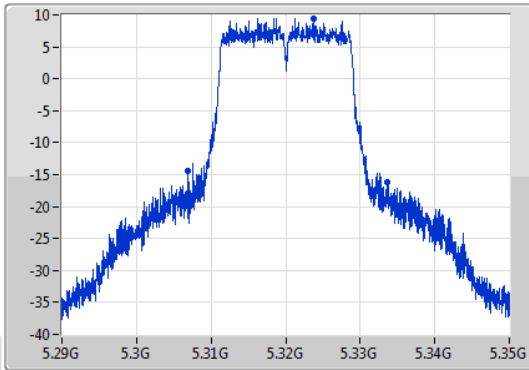

CF
5.32GHz
Span
60MHz
RBW
200kHz
VBW
1MHz
Sweep Time
100ms
Detector Type
Peak

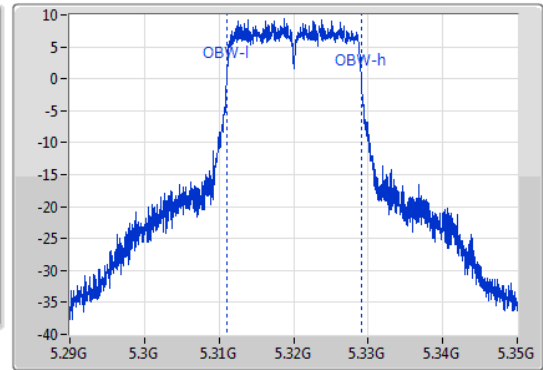

26dB(Hz)	Fl-26dB(Hz)	Fh-26dB(Hz)	OBW(Hz)	Fl-OBW(Hz)	Fh-OBW(Hz)	Limit(Hz)	Port
26.7M	5.30692G	5.33362G	18.081M	5.311034G	5.329115G	Inf	1

802.11ax HEW20_Nss1,(MCS0)_1TX

EBW

5500MHz

06/01/2020

CF
5.5GHz
Span
60MHz
RBW
200kHz
VBW
1MHz
Sweep Time
100ms
Detector Type
Peak
Port 1

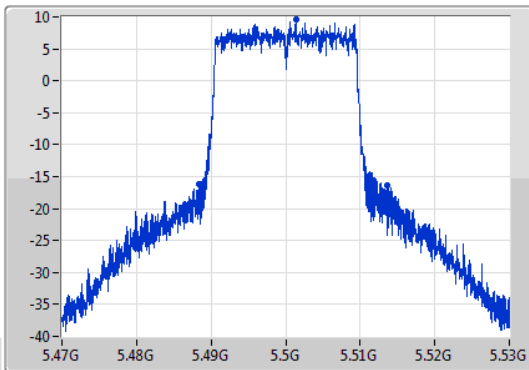

CF
5.5GHz
Span
60MHz
RBW
200kHz
VBW
1MHz
Sweep Time
100ms
Detector Type
Peak

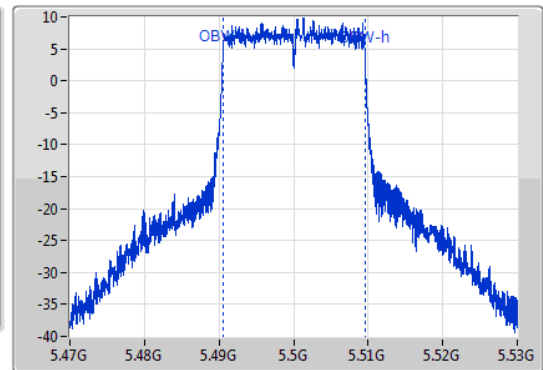

26dB(Hz)	Fl-26dB(Hz)	Fh-26dB(Hz)	OBW(Hz)	Fl-OBW(Hz)	Fh-OBW(Hz)	Limit(Hz)	Port
25.26M	5.48839G	5.51365G	19.1M	5.490495G	5.509595G	Inf	1

802.11ax HEW20_Nss1,(MCS0)_1TX

EBW

5580MHz

06/01/2020

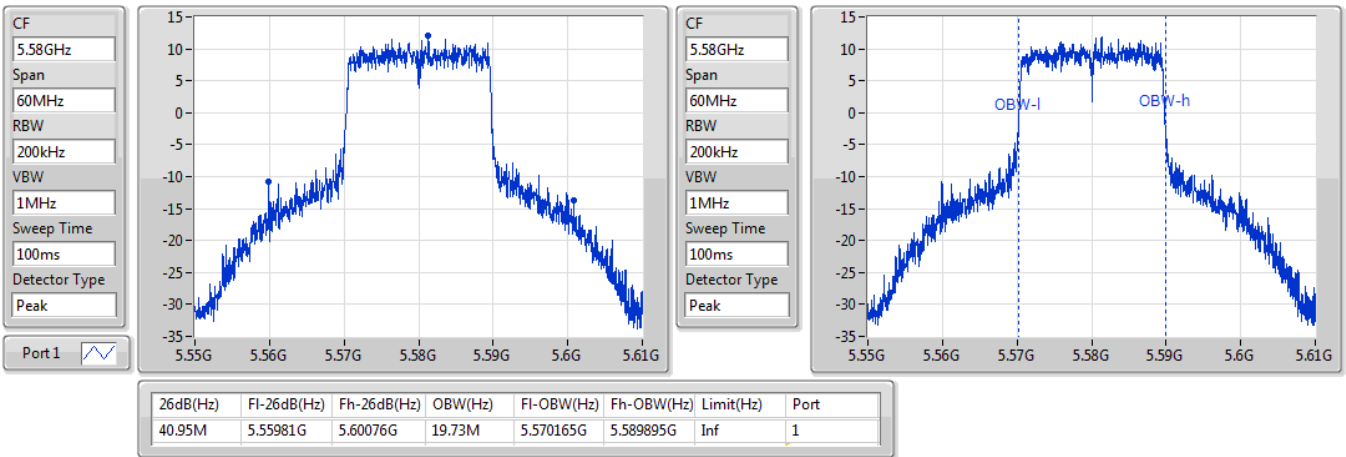

802.11ax HEW20_Nss1,(MCS0)_1TX

EBW

5700MHz

06/01/2020

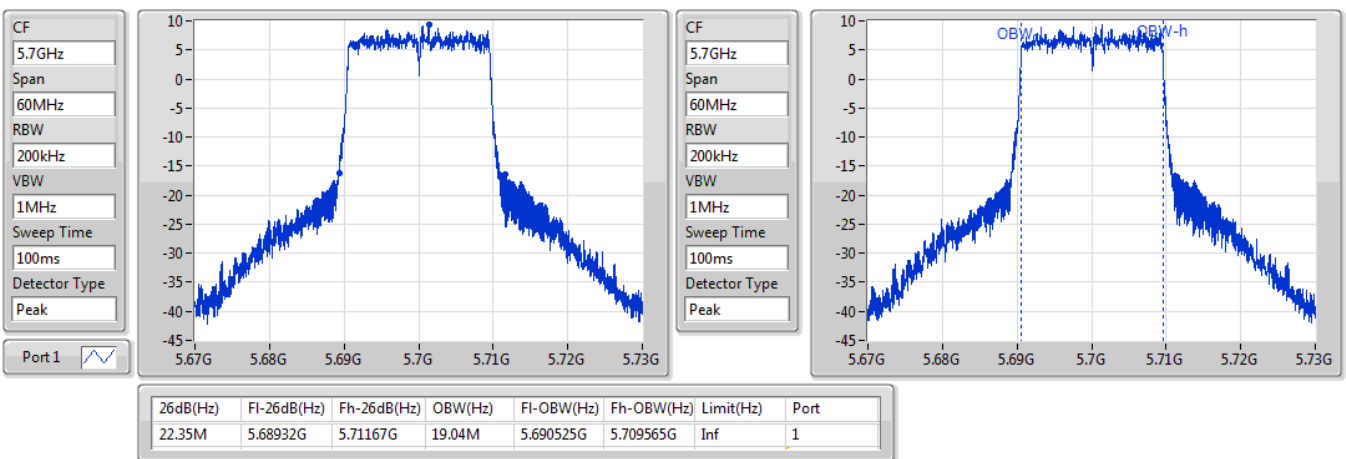

802.11ax HEW20_Nss1,(MCS0)_1TX
5720MHz Straddle 5.47-5.725GHz

EBW

06/01/2020

CF
5.7075GHz
Span
35MHz
RBW
200kHz
VBW
1MHz
Sweep Time
100ms
Detector Type
Peak
Port 1

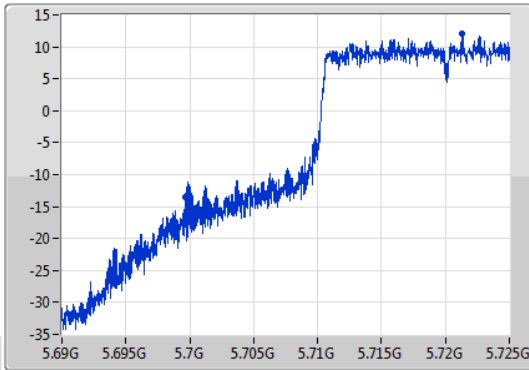

CF
5.7075GHz
Span
35MHz
RBW
200kHz
VBW
1MHz
Sweep Time
100ms
Detector Type
Peak

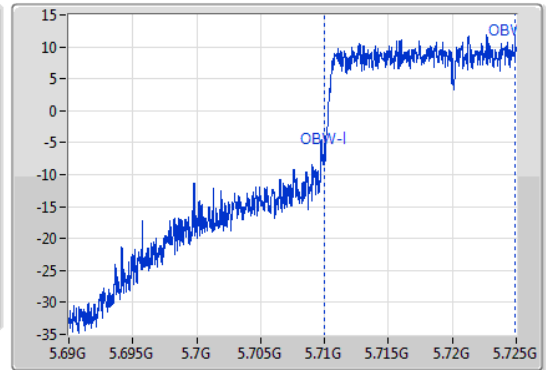

26dB(Hz)	Fl-26dB(Hz)	Fh-26dB(Hz)	OBW(Hz)	Fl-OBW(Hz)	Fh-OBW(Hz)	Limit(Hz)	Port
25.358M	5.699643G	5.725G	14.938M	5.710001G	5.724939G	Inf	1

802.11ax HEW20_Nss1,(MCS0)_1TX
5720MHz Straddle 5.725-5.85GHz

EBW

06/01/2020

CF
5.74GHz
Span
30MHz
RBW
100kHz
VBW
300kHz
Sweep Time
100ms
Detector Type
Peak
Port 1

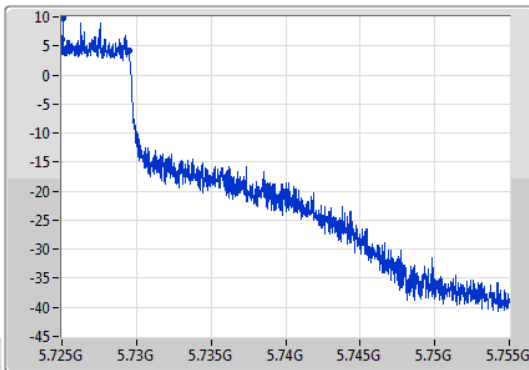

CF
5.74GHz
Span
30MHz
RBW
100kHz
VBW
300kHz
Sweep Time
100ms
Detector Type
Peak

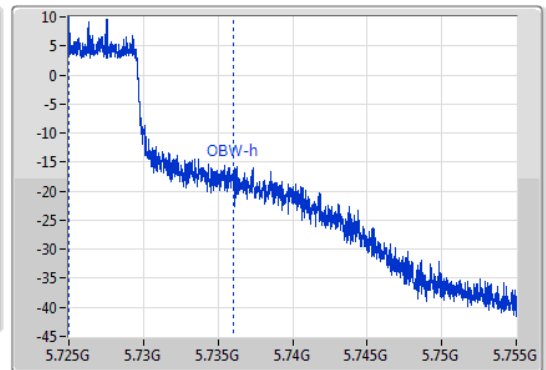

6dB(Hz)	Fl-6dB(Hz)	Fh-6dB(Hz)	OBW(Hz)	Fl-OBW(Hz)	Fh-OBW(Hz)	Limit(Hz)	Port
4.5M	5.725015G	5.729515G	10.975M	5.725022G	5.735997G	500k	1

802.11ax HEW40_Nss1,(MCS0)_1TX

EBW

5270MHz

06/01/2020

CF
5.27GHz
Span
120MHz
RBW
500kHz
VBW
2MHz
Sweep Time
100ms
Detector Type
Peak

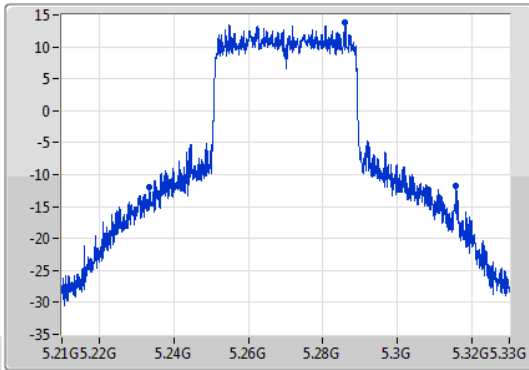

CF
5.27GHz
Span
120MHz
RBW
500kHz
VBW
2MHz
Sweep Time
100ms
Detector Type
Peak

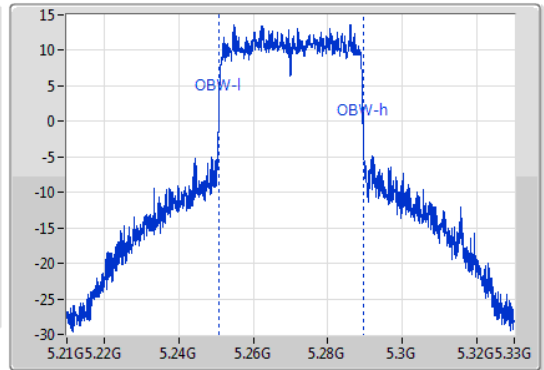

26dB(Hz)	Fl-26dB(Hz)	Fh-26dB(Hz)	OBW(Hz)	Fl-OBW(Hz)	Fh-OBW(Hz)	Limit(Hz)	Port
82.32M	5.2334G	5.31572G	38.741M	5.25075G	5.28949G	Inf	1

802.11ax HEW40_Nss1,(MCS0)_1TX

EBW

5310MHz

06/01/2020

CF
5.31GHz
Span
120MHz
RBW
500kHz
VBW
2MHz
Sweep Time
100ms
Detector Type
Peak

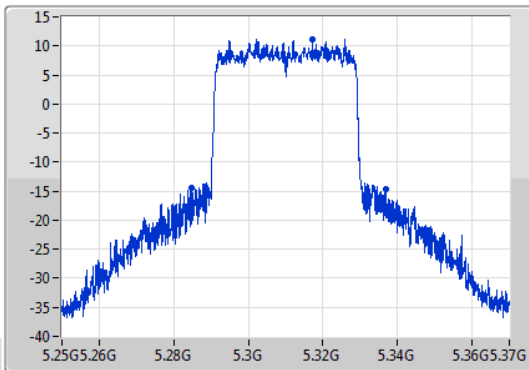

CF
5.31GHz
Span
120MHz
RBW
500kHz
VBW
2MHz
Sweep Time
100ms
Detector Type
Peak

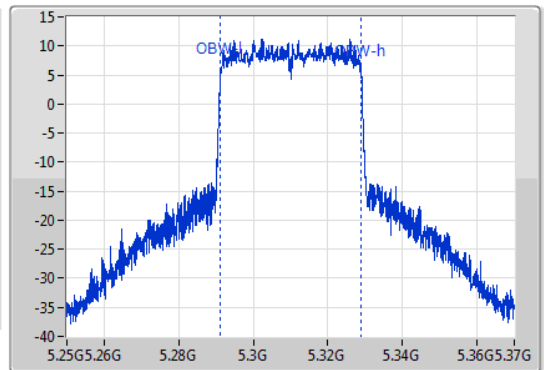

26dB(Hz)	Fl-26dB(Hz)	Fh-26dB(Hz)	OBW(Hz)	Fl-OBW(Hz)	Fh-OBW(Hz)	Limit(Hz)	Port
52.14M	5.28462G	5.33676G	37.721M	5.291229G	5.328951G	Inf	1

802.11ax HEW40_Nss1,(MCS0)_1TX

EBW

5510MHz

06/01/2020

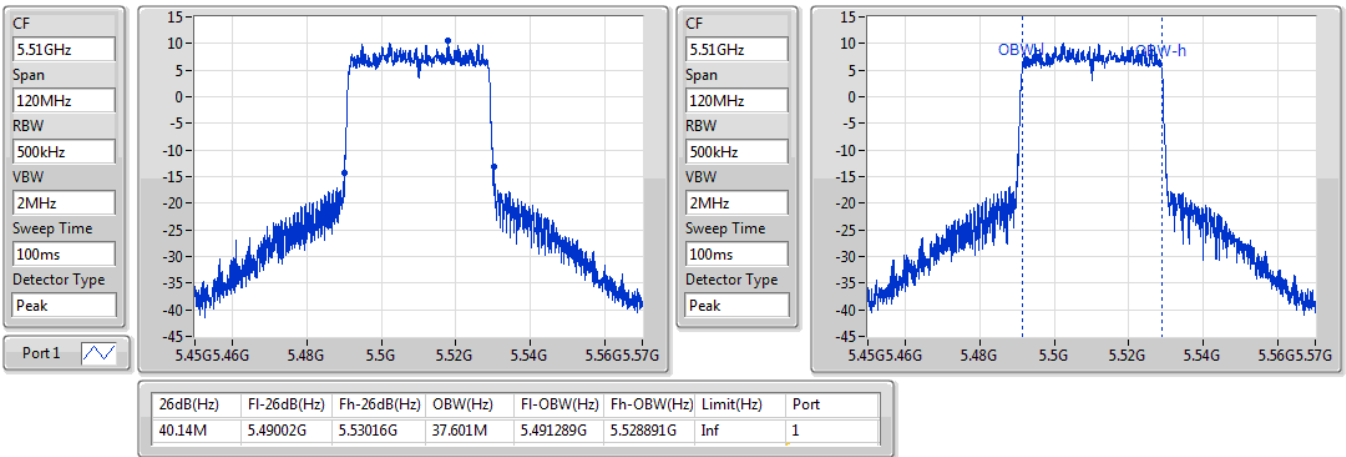

802.11ax HEW40_Nss1,(MCS0)_1TX

EBW

5550MHz

06/01/2020

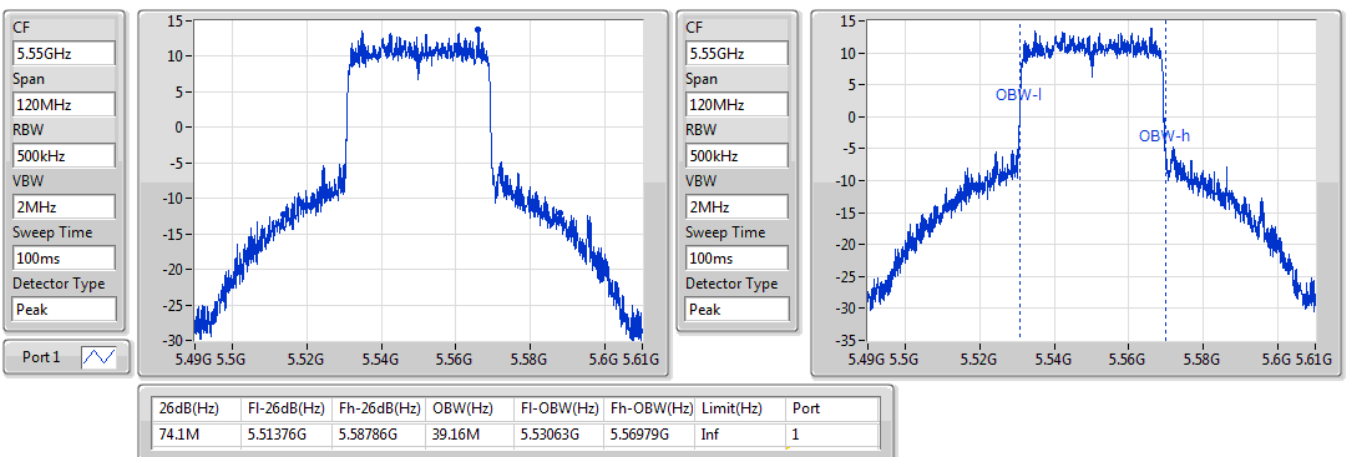

802.11ax HEW40_Nss1,(MCS0)_1TX

EBW

5670MHz

06/01/2020

CF
5.67GHz
Span
120MHz
RBW
500kHz
VBW
2MHz
Sweep Time
100ms
Detector Type
Peak
Port 1

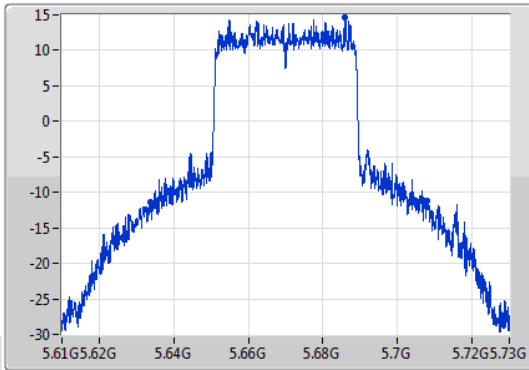

CF
5.67GHz
Span
120MHz
RBW
500kHz
VBW
2MHz
Sweep Time
100ms
Detector Type
Peak

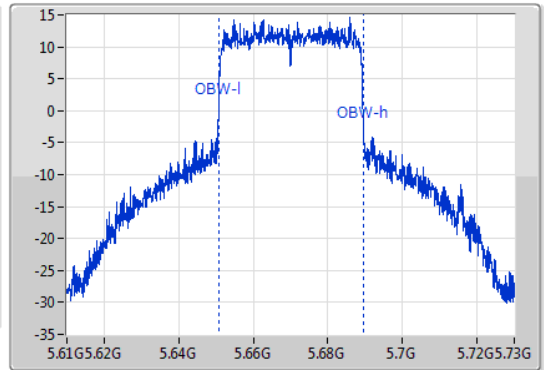

26dB(Hz)	Fl-26dB(Hz)	Fh-26dB(Hz)	OBW(Hz)	Fl-OBW(Hz)	Fh-OBW(Hz)	Limit(Hz)	Port
74.4M	5.63358G	5.70798G	39.04M	5.65063G	5.68967G	Inf	1

802.11ax HEW40_Nss1,(MCS0)_1TX

EBW

5710MHz Straddle 5.47-5.725GHz

06/01/2020

CF
5.6875GHz
Span
75MHz
RBW
500kHz
VBW
2MHz
Sweep Time
100ms
Detector Type
Peak
Port 1

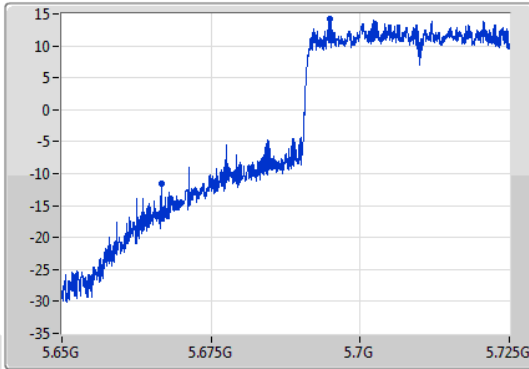

CF
5.6875GHz
Span
75MHz
RBW
500kHz
VBW
2MHz
Sweep Time
100ms
Detector Type
Peak

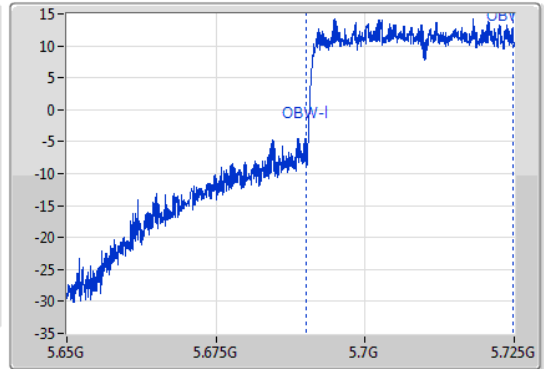

26dB(Hz)	Fl-26dB(Hz)	Fh-26dB(Hz)	OBW(Hz)	Fl-OBW(Hz)	Fh-OBW(Hz)	Limit(Hz)	Port
58.275M	5.666725G	5.725G	34.783M	5.690011G	5.724794G	Inf	1

802.11ax HEW40_Nss1,(MCS0)_1TX

EBW

5710MHz Straddle 5.725-5.85GHz

06/01/2020

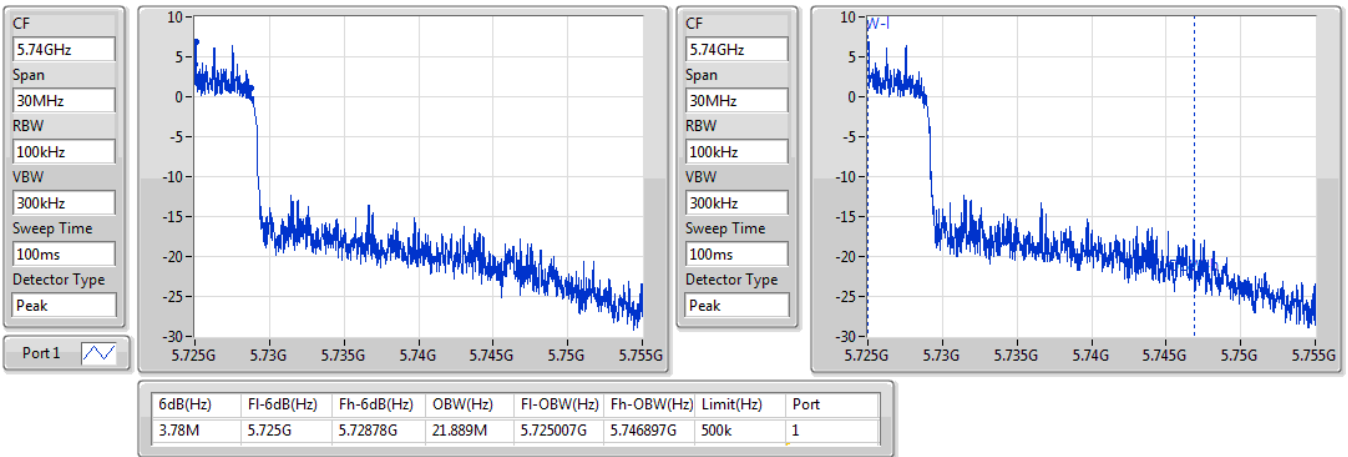

802.11ax HEW80_Nss1,(MCS0)_1TX

EBW

5290MHz

06/01/2020

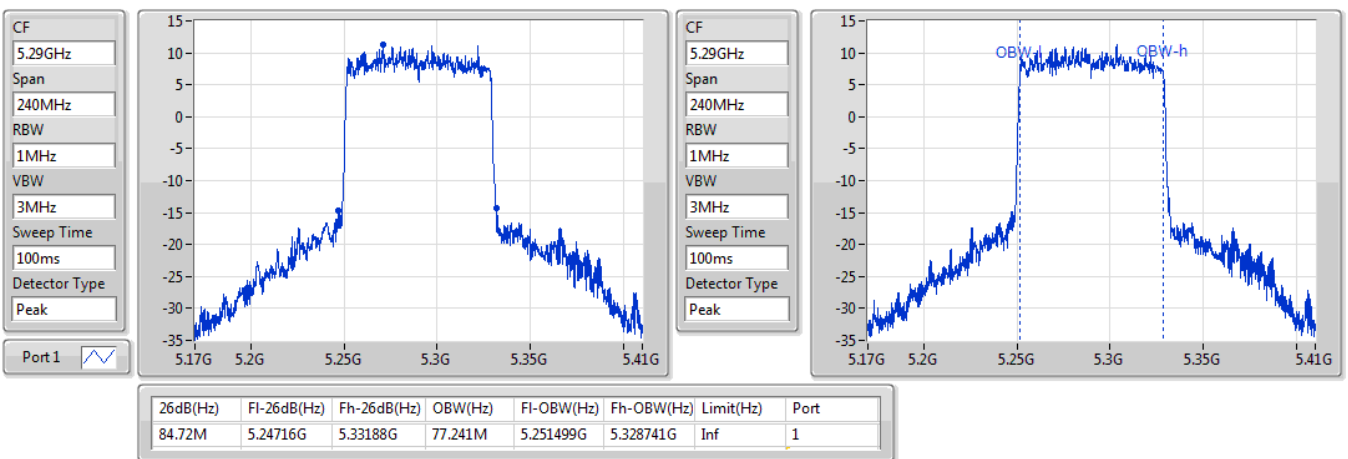

802.11ax HEW80_Nss1,(MCS0)_1TX

EBW

5530MHz

06/01/2020

CF
5.53GHz
Span
240MHz
RBW
1MHz
VBW
3MHz
Sweep Time
100ms
Detector Type
Peak
Port 1

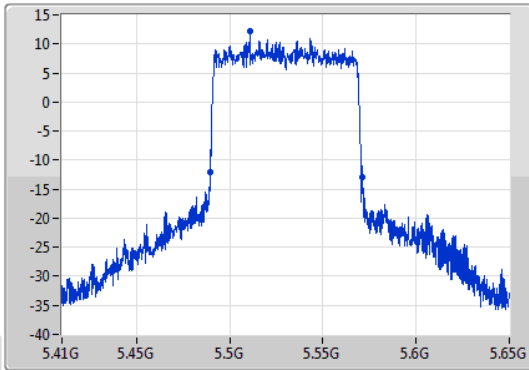

CF
5.53GHz
Span
240MHz
RBW
1MHz
VBW
3MHz
Sweep Time
100ms
Detector Type
Peak

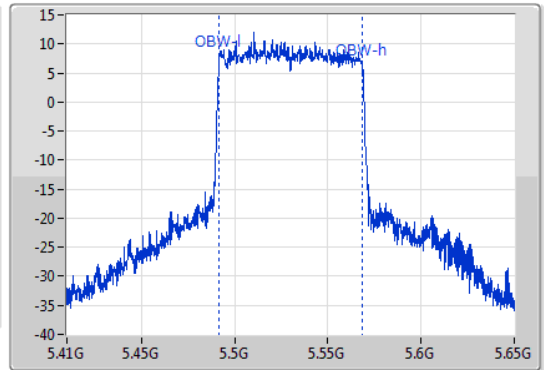

26dB(Hz)	Fl-26dB(Hz)	Fh-26dB(Hz)	OBW(Hz)	Fl-OBW(Hz)	Fh-OBW(Hz)	Limit(Hz)	Port
81.96M	5.48944G	5.5714G	77.241M	5.491499G	5.568741G	Inf	1

802.11ax HEW80_Nss1,(MCS0)_1TX

EBW

5610MHz

06/01/2020

CF
5.61GHz
Span
240MHz
RBW
1MHz
VBW
3MHz
Sweep Time
100ms
Detector Type
Peak
Port 1

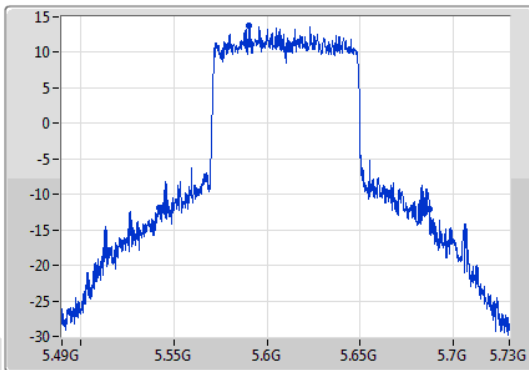

CF
5.61GHz
Span
240MHz
RBW
1MHz
VBW
3MHz
Sweep Time
100ms
Detector Type
Peak

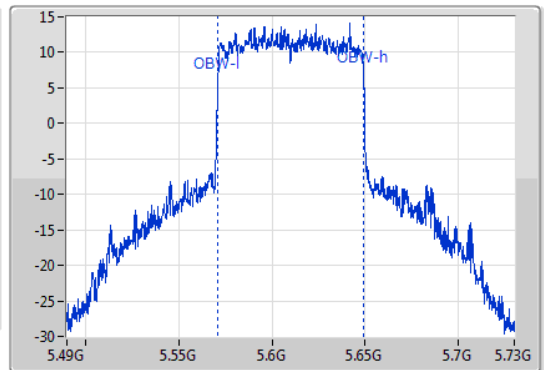

26dB(Hz)	Fl-26dB(Hz)	Fh-26dB(Hz)	OBW(Hz)	Fl-OBW(Hz)	Fh-OBW(Hz)	Limit(Hz)	Port
145.44M	5.54184G	5.68728G	78.441M	5.5709G	5.64934G	Inf	1

802.11ax HEW80_Nss1,(MCS0)_1TX

EBW

5690MHz Straddle 5.47-5.725GHz

06/01/2020

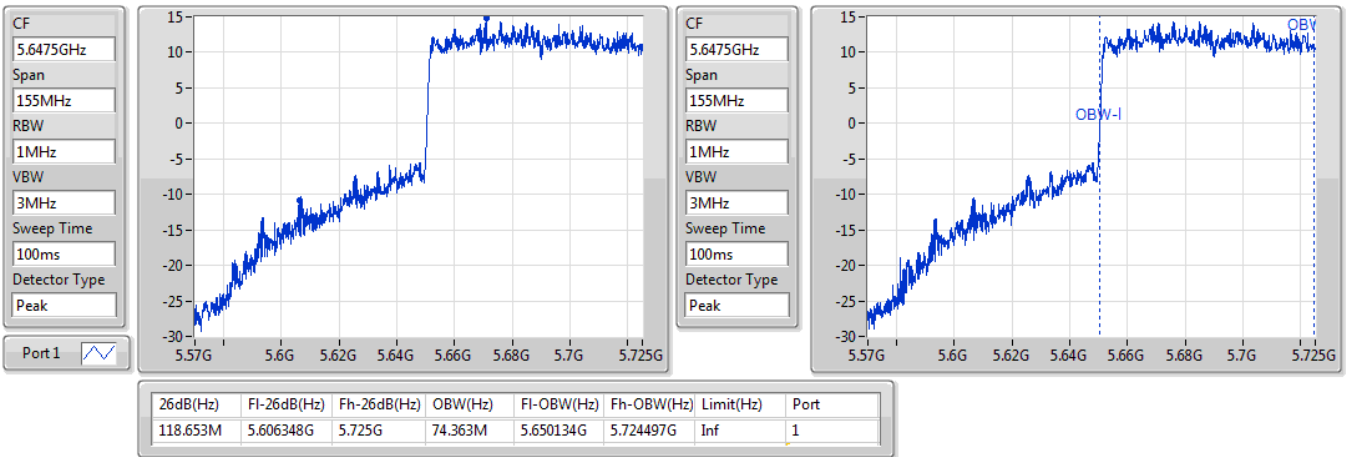

802.11ax HEW80_Nss1,(MCS0)_1TX

EBW

5690MHz Straddle 5.725-5.85GHz

06/01/2020

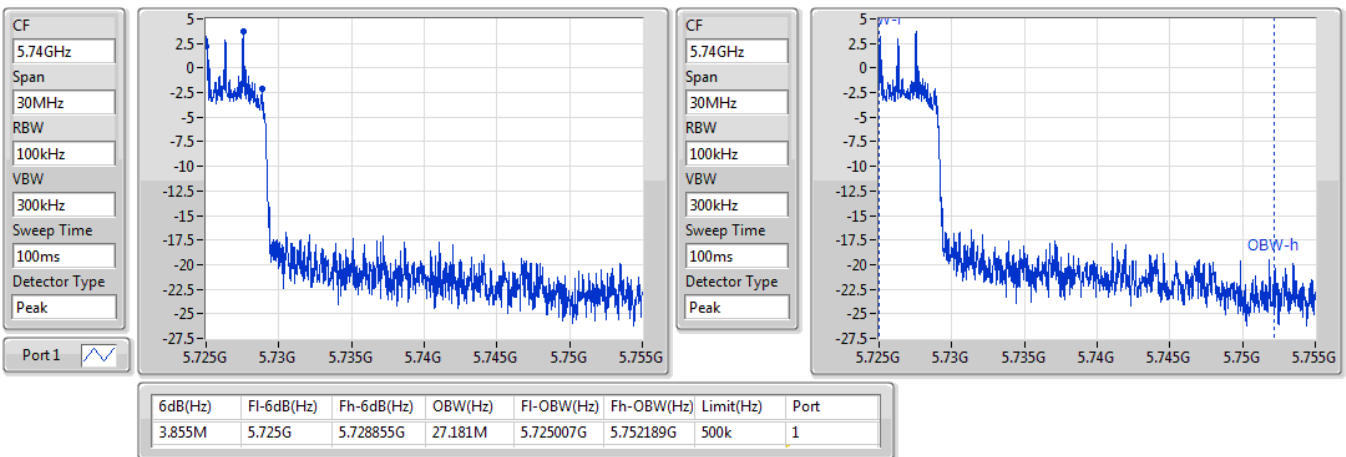



Summary

Mode	Max-N dB (Hz)	Max-OBW (Hz)	ITU-Code	Min-N dB (Hz)	Min-OBW (Hz)
5.25-5.35GHz	-	-	-	-	-
802.11a_Nss1,(6Mbps)_2TX	26.97M	16.912M	16M9D1D	21.75M	16.852M
802.11ac VHT20_Nss2,(MCS0)_2TX	38.64M	19.4M	19M4D1D	27.57M	18.171M
802.11ac VHT40_Nss2,(MCS0)_2TX	78.18M	38.261M	38M3D1D	40.2M	36.342M
802.11ac VHT80_Nss2,(MCS0)_2TX	81.72M	75.922M	75M9D1D	81.48M	75.922M
802.11ax HEW20_Nss2,(MCS0)_2TX	41.82M	19.64M	19M6D1D	28.29M	19.16M
802.11ax HEW40_Nss2,(MCS0)_2TX	74.52M	38.381M	38M4D1D	51M	37.721M
802.11ax HEW80_Nss2,(MCS0)_2TX	81.48M	77.241M	77M2D1D	81.12M	77.241M
5.47-5.725GHz	-	-	-	-	-
802.11a_Nss1,(6Mbps)_2TX	24.48M	16.882M	16M9D1D	15.698M	13.363M
802.11ac VHT20_Nss2,(MCS0)_2TX	35.76M	18.651M	18M7D1D	20.563M	14.5M
802.11ac VHT40_Nss2,(MCS0)_2TX	71.46M	37.001M	37M0D1D	39.84M	33.283M
802.11ac VHT80_Nss2,(MCS0)_2TX	147.6M	77.121M	77M1D1D	81.6M	72.814M
802.11ax HEW20_Nss2,(MCS0)_2TX	40.71M	19.43M	19M4D1D	21.33M	14.745M
802.11ax HEW40_Nss2,(MCS0)_2TX	71.52M	38.441M	38M4D1D	39.96M	33.846M
802.11ax HEW80_Nss2,(MCS0)_2TX	152.04M	78.561M	78M6D1D	81.36M	73.356M
5.725-5.85GHz	-	-	-	-	-
802.11a_Nss1,(6Mbps)_2TX	3.21M	4.978M	4M98D1D	3.21M	4.753M
802.11ac VHT20_Nss2,(MCS0)_2TX	3.825M	9.7M	9M70D1D	3.825M	8.021M
802.11ac VHT40_Nss2,(MCS0)_2TX	3.21M	19.49M	19M5D1D	3.21M	18.801M
802.11ac VHT80_Nss2,(MCS0)_2TX	3.195M	25.172M	25M2D1D	3.195M	23.778M
802.11ax HEW20_Nss2,(MCS0)_2TX	4.515M	11.589M	11M6D1D	4.5M	9.61M
802.11ax HEW40_Nss2,(MCS0)_2TX	3.855M	20.45M	20M4D1D	3.75M	20.435M
802.11ax HEW80_Nss2,(MCS0)_2TX	3.42M	25.532M	25M5D1D	3.165M	23.883M

Max-N dB = Maximum 6dB down bandwidth for 5.725-5.85GHz band / Maximum 26dB down bandwidth for other band;

Max-OBW = Maximum 99% occupied bandwidth;

Min-N dB = Minimum 6dB down bandwidth for 5.725-5.85GHz band / Maximum 26dB down bandwidth for other band;

Min-OBW = Minimum 99% occupied bandwidth;



Result

Mode	Result	Limit (Hz)	Port 1-N dB (Hz)	Port 1-OBW (Hz)	Port 2-N dB (Hz)	Port 2-OBW (Hz)
802.11a_Nss1,(6Mbps)_2TX	-	-	-	-	-	-
5260MHz	Pass	Inf	22.83M	16.912M	24.45M	16.912M
5300MHz	Pass	Inf	21.75M	16.852M	26.97M	16.912M
5320MHz	Pass	Inf	21.75M	16.882M	24.36M	16.912M
5500MHz	Pass	Inf	22.68M	16.882M	24.48M	16.882M
5580MHz	Pass	Inf	21.75M	16.852M	22.29M	16.852M
5700MHz	Pass	Inf	21.78M	16.852M	22.29M	16.792M
5720MHz Straddle 5.47-5.725GHz	Pass	Inf	15.698M	13.363M	15.943M	13.398M
5720MHz Straddle 5.725-5.85GHz	Pass	500k	3.21M	4.753M	3.21M	4.978M
802.11ac VHT20_Nss2,(MCS0)_2TX	-	-	-	-	-	-
5260MHz	Pass	Inf	34.35M	18.681M	38.64M	19.4M
5300MHz	Pass	Inf	32.85M	18.621M	38.55M	19.19M
5320MHz	Pass	Inf	27.57M	18.171M	33.66M	18.231M
5500MHz	Pass	Inf	31.08M	18.501M	34.56M	18.321M
5580MHz	Pass	Inf	33.72M	18.591M	35.76M	18.651M
5700MHz	Pass	Inf	21.72M	17.931M	21.78M	17.841M
5720MHz Straddle 5.47-5.725GHz	Pass	Inf	20.563M	14.5M	24.185M	14.605M
5720MHz Straddle 5.725-5.85GHz	Pass	500k	3.825M	8.021M	3.825M	9.7M
802.11ac VHT40_Nss2,(MCS0)_2TX	-	-	-	-	-	-
5270MHz	Pass	Inf	78.18M	38.261M	71.76M	37.241M
5310MHz	Pass	Inf	40.38M	36.522M	40.2M	36.342M
5510MHz	Pass	Inf	39.84M	36.402M	40.2M	36.342M
5550MHz	Pass	Inf	64.56M	37.001M	71.46M	36.822M
5670MHz	Pass	Inf	66.72M	37.001M	67.5M	36.642M
5710MHz Straddle 5.47-5.725GHz	Pass	Inf	53.288M	33.621M	44.963M	33.283M
5710MHz Straddle 5.725-5.85GHz	Pass	500k	3.21M	19.49M	3.21M	18.801M
802.11ac VHT80_Nss2,(MCS0)_2TX	-	-	-	-	-	-
5290MHz	Pass	Inf	81.48M	75.922M	81.72M	75.922M
5530MHz	Pass	Inf	81.96M	76.042M	81.6M	76.042M
5610MHz	Pass	Inf	134.52M	76.642M	147.6M	77.121M
5690MHz Straddle 5.47-5.725GHz	Pass	Inf	110.128M	72.814M	107.725M	72.891M
5690MHz Straddle 5.725-5.85GHz	Pass	500k	3.195M	23.778M	3.195M	25.172M
802.11ax HEW20_Nss2,(MCS0)_2TX	-	-	-	-	-	-
5260MHz	Pass	Inf	35.16M	19.31M	41.82M	19.64M
5300MHz	Pass	Inf	36.81M	19.28M	41.67M	19.49M
5320MHz	Pass	Inf	28.29M	19.16M	41.07M	19.34M
5500MHz	Pass	Inf	33.24M	19.22M	36.39M	19.28M
5580MHz	Pass	Inf	35.13M	19.31M	40.71M	19.43M
5700MHz	Pass	Inf	21.63M	19.04M	21.33M	19.1M
5720MHz Straddle 5.47-5.725GHz	Pass	Inf	23.853M	14.745M	25.498M	14.885M
5720MHz Straddle 5.725-5.85GHz	Pass	500k	4.515M	9.61M	4.5M	11.589M
802.11ax HEW40_Nss2,(MCS0)_2TX	-	-	-	-	-	-
5270MHz	Pass	Inf	74.52M	38.381M	71.1M	38.381M
5310MHz	Pass	Inf	51M	37.781M	52.92M	37.721M



Mode	Result	Limit (Hz)	Port 1-N dB (Hz)	Port 1-OBW (Hz)	Port 2-N dB (Hz)	Port 2-OBW (Hz)
5510MHz	Pass	Inf	40.08M	37.721M	39.96M	37.541M
5550MHz	Pass	Inf	71.22M	38.201M	71.52M	38.441M
5670MHz	Pass	Inf	70.98M	38.021M	69.18M	37.961M
5710MHz Straddle 5.47-5.725GHz	Pass	Inf	52.613M	34.22M	50.775M	33.846M
5710MHz Straddle 5.725-5.85GHz	Pass	500k	3.75M	20.435M	3.855M	20.45M
802.11ax HEW80_Nss2,(MCS0)_2TX	-	-	-	-	-	-
5290MHz	Pass	Inf	81.12M	77.241M	81.48M	77.241M
5530MHz	Pass	Inf	81.36M	77.241M	81.72M	77.241M
5610MHz	Pass	Inf	123M	77.841M	152.04M	78.561M
5690MHz Straddle 5.47-5.725GHz	Pass	Inf	97.883M	73.356M	105.633M	73.511M
5690MHz Straddle 5.725-5.85GHz	Pass	500k	3.42M	23.883M	3.165M	25.532M

Port X-N dB = Port X 6dB down bandwidth for 5.725-5.85GHz band / 26dB down bandwidth for other band

Port X-OBW = Port X 99% occupied bandwidth;

802.11a_Nss1,(6Mbps)_2TX

EBW

5260MHz

06/01/2020

CF: 5.26GHz
 Span: 60MHz
 RBW: 200kHz
 VBW: 1MHz
 Sweep Time: 100ms
 Detector Type: Peak

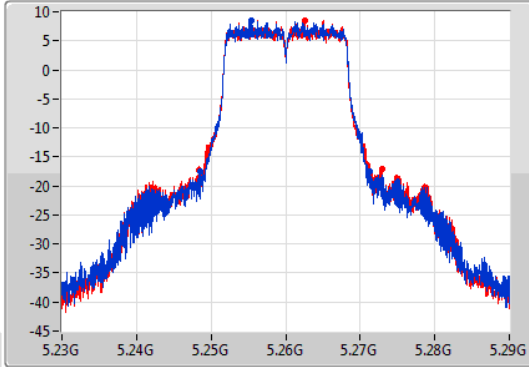

CF: 5.26GHz
 Span: 60MHz
 RBW: 200kHz
 VBW: 1MHz
 Sweep Time: 100ms
 Detector Type: Peak

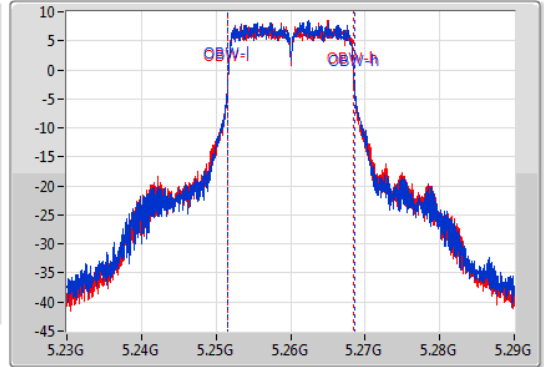

26dB(Hz)	Fl-26dB(Hz)	Fh-26dB(Hz)	OBW(Hz)	Fl-OBW(Hz)	Fh-OBW(Hz)	Limit(Hz)	Port
22.83M	5.24851G	5.27134G	16.912M	5.251634G	5.268546G	Inf	1
24.45M	5.24842G	5.27287G	16.912M	5.251604G	5.268516G	Inf	2

802.11a_Nss1,(6Mbps)_2TX

EBW

5300MHz

06/01/2020

CF: 5.3GHz
 Span: 60MHz
 RBW: 200kHz
 VBW: 1MHz
 Sweep Time: 100ms
 Detector Type: Peak

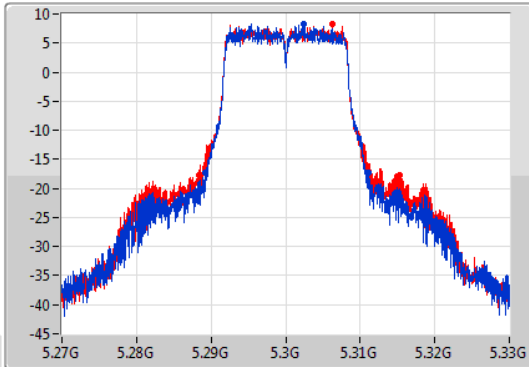

CF: 5.3GHz
 Span: 60MHz
 RBW: 200kHz
 VBW: 1MHz
 Sweep Time: 100ms
 Detector Type: Peak

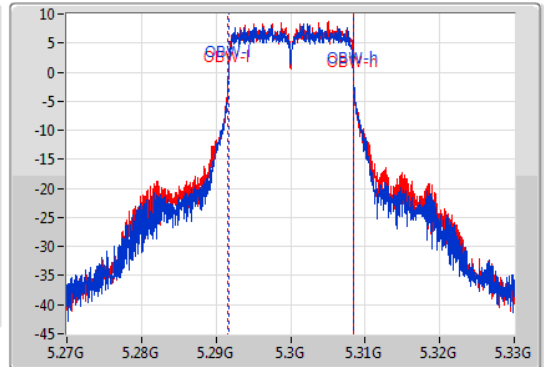

26dB(Hz)	Fl-26dB(Hz)	Fh-26dB(Hz)	OBW(Hz)	Fl-OBW(Hz)	Fh-OBW(Hz)	Limit(Hz)	Port
21.75M	5.28929G	5.31104G	16.852M	5.291664G	5.308516G	Inf	1
26.97M	5.28833G	5.3153G	16.912M	5.291604G	5.308516G	Inf	2

802.11a_Nss1,(6Mbps)_2TX

EBW

5320MHz

06/01/2020

CF
5.32GHz
Span
60MHz
RBW
200kHz
VBW
1MHz
Sweep Time
100ms
Detector Type
Peak

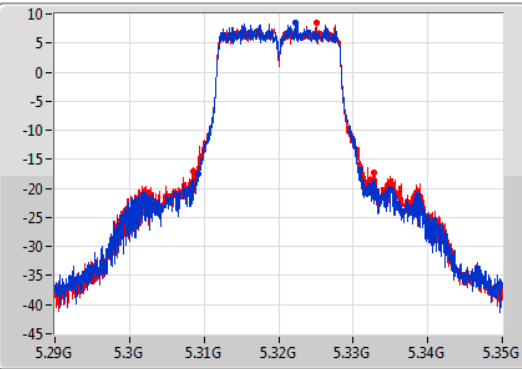

CF
5.32GHz
Span
60MHz
RBW
200kHz
VBW
1MHz
Sweep Time
100ms
Detector Type
Peak

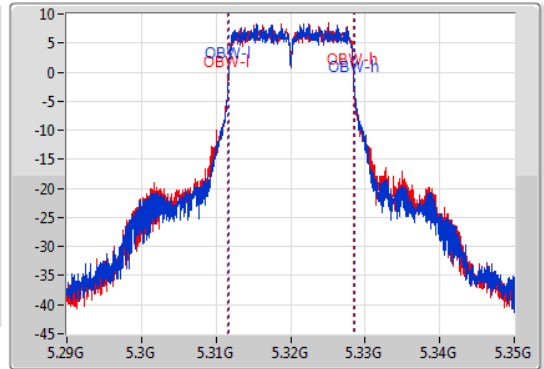

26dB(Hz)	Fl-26dB(Hz)	Fh-26dB(Hz)	OBW(Hz)	Fl-OBW(Hz)	Fh-OBW(Hz)	Limit(Hz)	Port
21.75M	5.30926G	5.33101G	16.882M	5.311664G	5.328546G	Inf	1
24.36M	5.30848G	5.33284G	16.912M	5.311604G	5.328516G	Inf	2

802.11a_Nss1,(6Mbps)_2TX

EBW

5500MHz

06/01/2020

CF
5.5GHz
Span
60MHz
RBW
200kHz
VBW
1MHz
Sweep Time
100ms
Detector Type
Peak

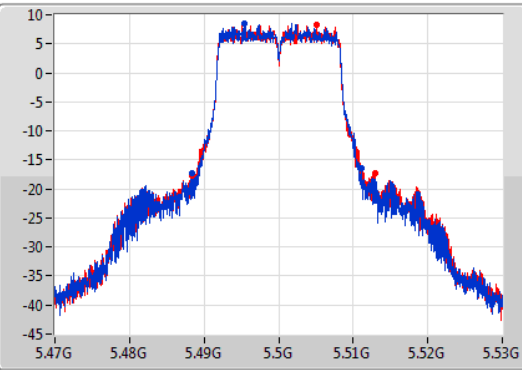

CF
5.5GHz
Span
60MHz
RBW
200kHz
VBW
1MHz
Sweep Time
100ms
Detector Type
Peak

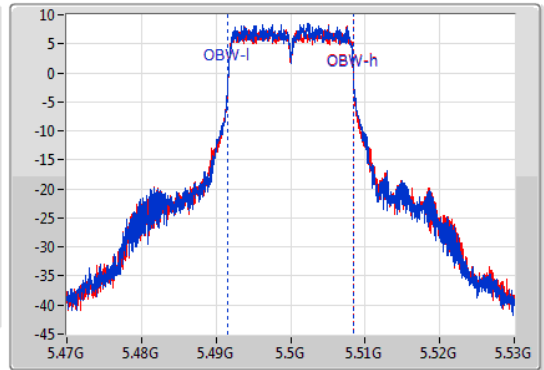

26dB(Hz)	Fl-26dB(Hz)	Fh-26dB(Hz)	OBW(Hz)	Fl-OBW(Hz)	Fh-OBW(Hz)	Limit(Hz)	Port
22.68M	5.48839G	5.51107G	16.882M	5.491634G	5.508516G	Inf	1
24.48M	5.48842G	5.5129G	16.882M	5.491634G	5.508516G	Inf	2

802.11a_Nss1,(6Mbps)_2TX

EBW

5580MHz

06/01/2020

CF
5.58GHz
Span
60MHz
RBW
200kHz
VBW
1MHz
Sweep Time
100ms
Detector Type
Peak

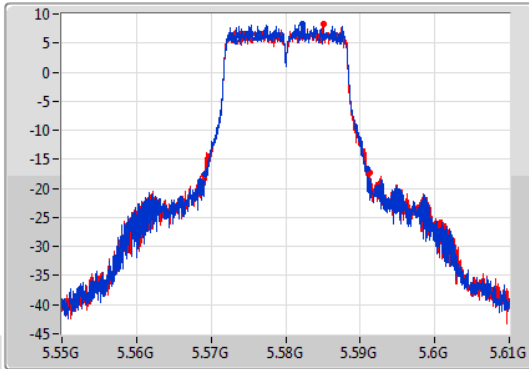

CF
5.58GHz
Span
60MHz
RBW
200kHz
VBW
1MHz
Sweep Time
100ms
Detector Type
Peak

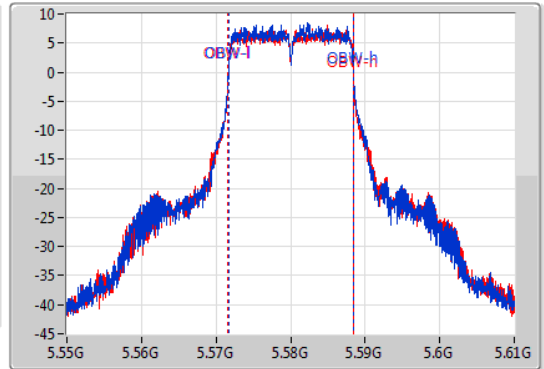

26dB(Hz)	Fl-26dB(Hz)	Fh-26dB(Hz)	OBW(Hz)	Fl-OBW(Hz)	Fh-OBW(Hz)	Limit(Hz)	Port
21.75M	5.56926G	5.59101G	16.852M	5.571664G	5.588516G	Inf	1
22.29M	5.56902G	5.59131G	16.852M	5.571634G	5.588486G	Inf	2

802.11a_Nss1,(6Mbps)_2TX

EBW

5700MHz

06/01/2020

CF
5.7GHz
Span
60MHz
RBW
200kHz
VBW
1MHz
Sweep Time
100ms
Detector Type
Peak

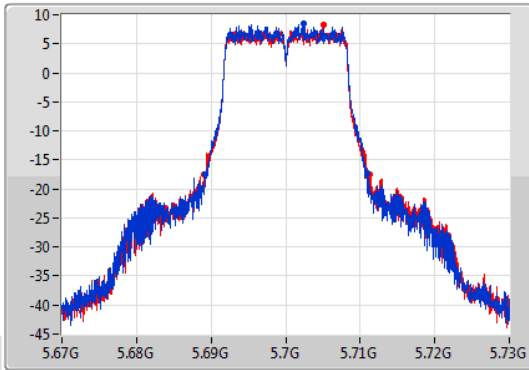

CF
5.7GHz
Span
60MHz
RBW
200kHz
VBW
1MHz
Sweep Time
100ms
Detector Type
Peak

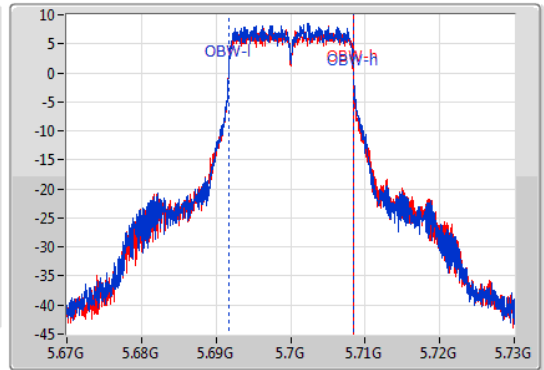

26dB(Hz)	Fl-26dB(Hz)	Fh-26dB(Hz)	OBW(Hz)	Fl-OBW(Hz)	Fh-OBW(Hz)	Limit(Hz)	Port
21.78M	5.6892G	5.71098G	16.852M	5.691664G	5.708516G	Inf	1
22.29M	5.68899G	5.71128G	16.792M	5.691664G	5.708456G	Inf	2

802.11a_Nss1,(6Mbps)_2TX

EBW

5720MHz Straddle 5.47-5.725GHz

06/01/2020

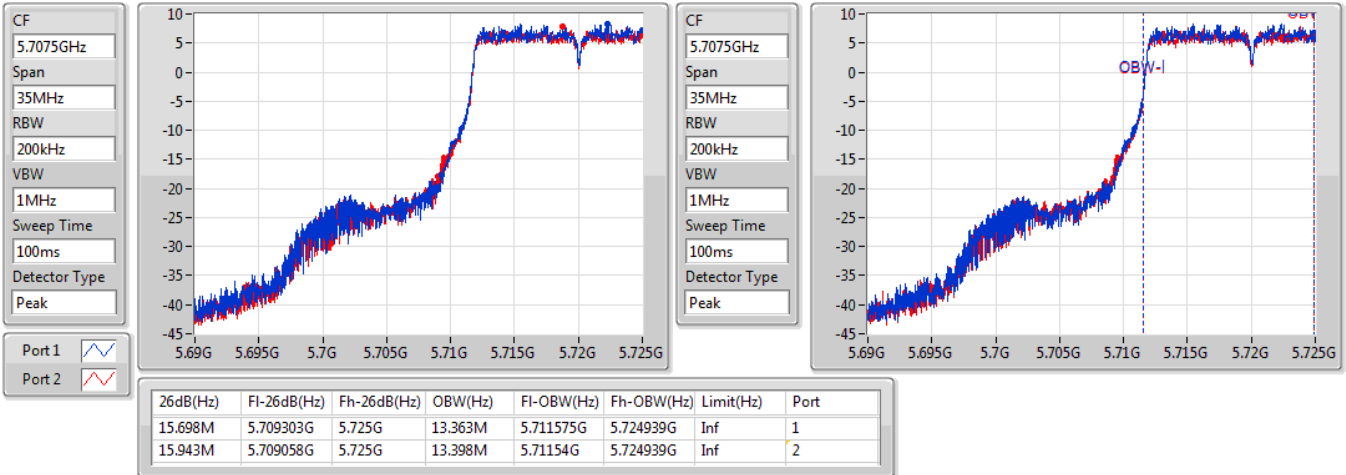

802.11a_Nss1,(6Mbps)_2TX

EBW

5720MHz Straddle 5.725-5.85GHz

06/01/2020

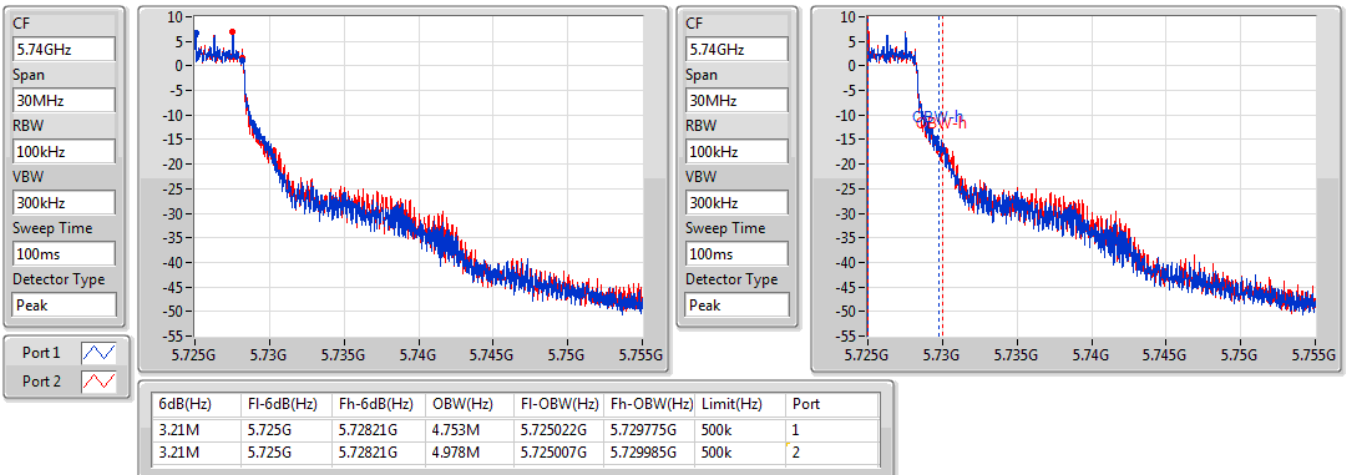

802.11ac VHT20_Nss2,(MCS0)_2TX

EBW

5260MHz

06/01/2020

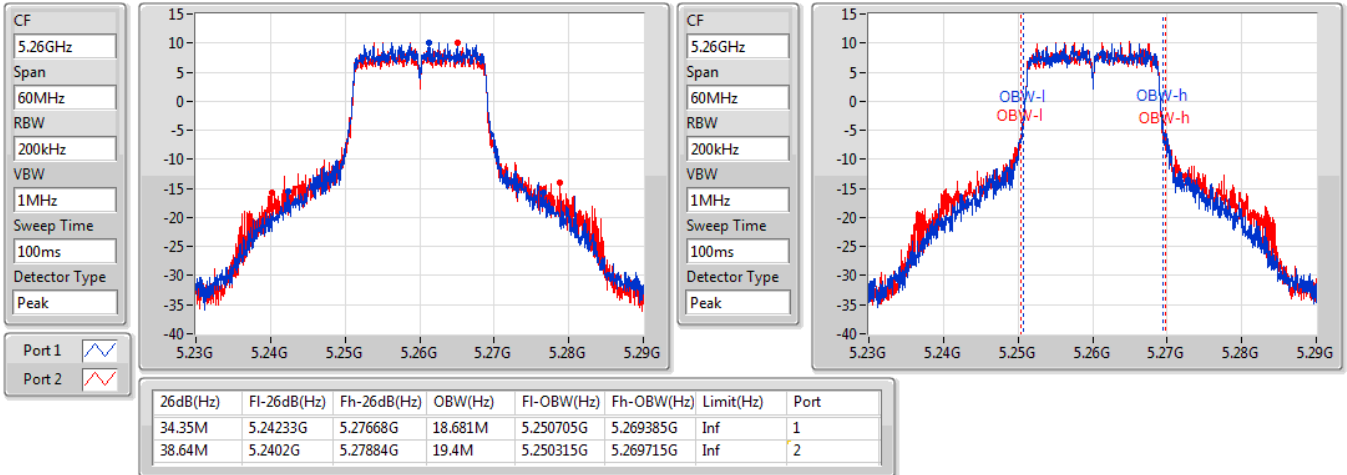

802.11ac VHT20_Nss2,(MCS0)_2TX

EBW

5300MHz

06/01/2020

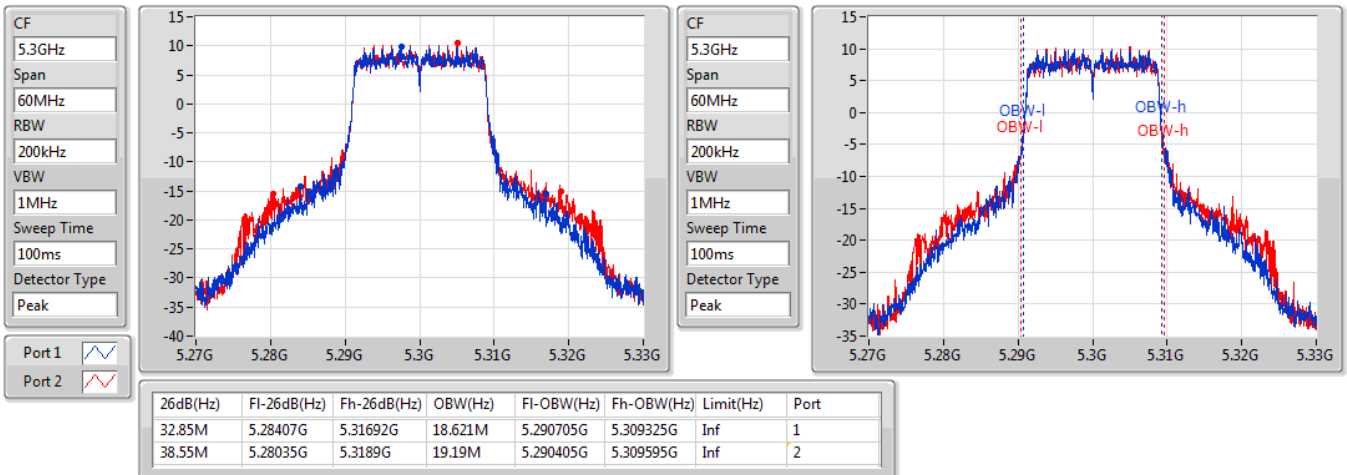

802.11ac VHT20_Nss2,(MCS0)_2TX

EBW

5320MHz

06/01/2020

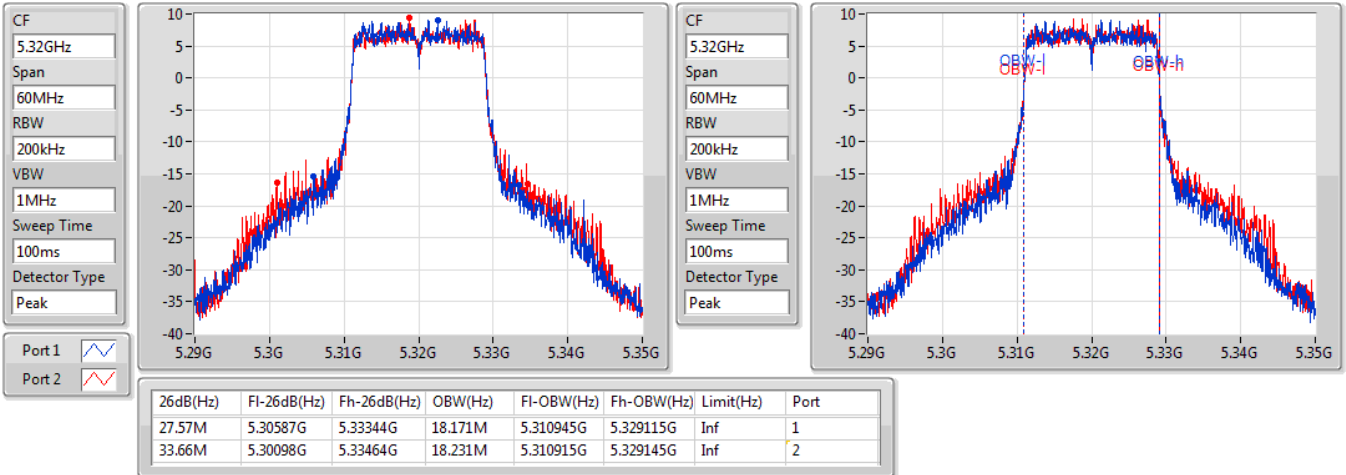

802.11ac VHT20_Nss2,(MCS0)_2TX

EBW

5500MHz

06/01/2020

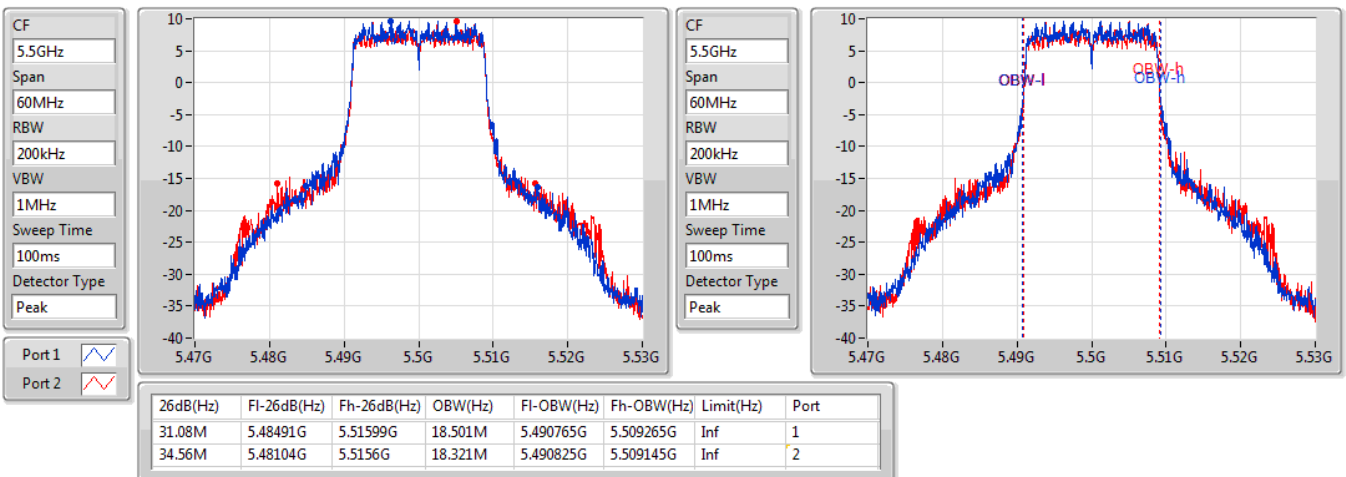

802.11ac VHT20_Nss2,(MCS0)_2TX

EBW

5580MHz

06/01/2020

CF
5.58GHz
Span
60MHz
RBW
200kHz
VBW
1MHz
Sweep Time
100ms
Detector Type
Peak

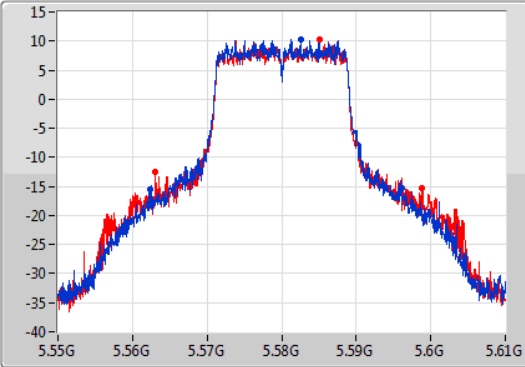

CF
5.58GHz
Span
60MHz
RBW
200kHz
VBW
1MHz
Sweep Time
100ms
Detector Type
Peak

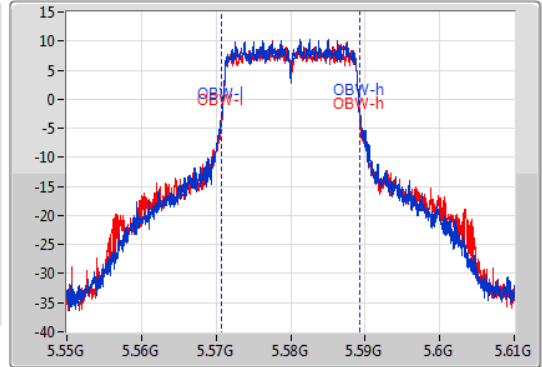

26dB(Hz)	Fl-26dB(Hz)	Fh-26dB(Hz)	OBW(Hz)	Fl-OBW(Hz)	Fh-OBW(Hz)	Limit(Hz)	Port
33.72M	5.56233G	5.59605G	18.591M	5.570765G	5.589355G	Inf	1
35.76M	5.56311G	5.59887G	18.651M	5.570705G	5.589355G	Inf	2

802.11ac VHT20_Nss2,(MCS0)_2TX

EBW

5700MHz

06/01/2020

CF
5.7GHz
Span
60MHz
RBW
200kHz
VBW
1MHz
Sweep Time
100ms
Detector Type
Peak

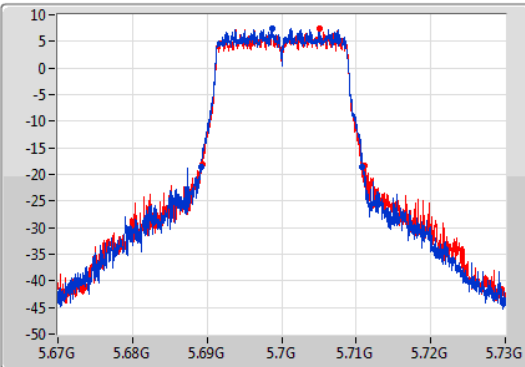

CF
5.7GHz
Span
60MHz
RBW
200kHz
VBW
1MHz
Sweep Time
100ms
Detector Type
Peak

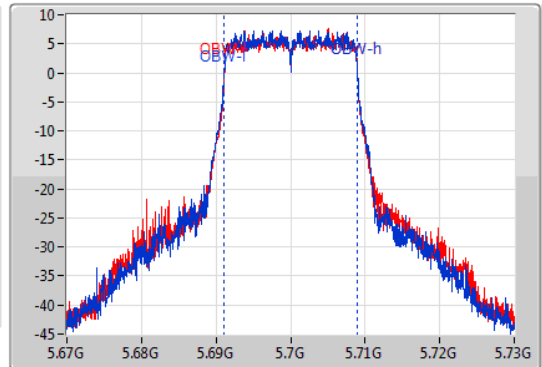

26dB(Hz)	Fl-26dB(Hz)	Fh-26dB(Hz)	OBW(Hz)	Fl-OBW(Hz)	Fh-OBW(Hz)	Limit(Hz)	Port
21.72M	5.68914G	5.71086G	17.931M	5.691064G	5.708996G	Inf	1
21.78M	5.68932G	5.7111G	17.841M	5.691124G	5.708966G	Inf	2

802.11ac VHT20_Nss2,(MCS0)_2TX

EBW

5720MHz Straddle 5.47-5.725GHz

06/01/2020

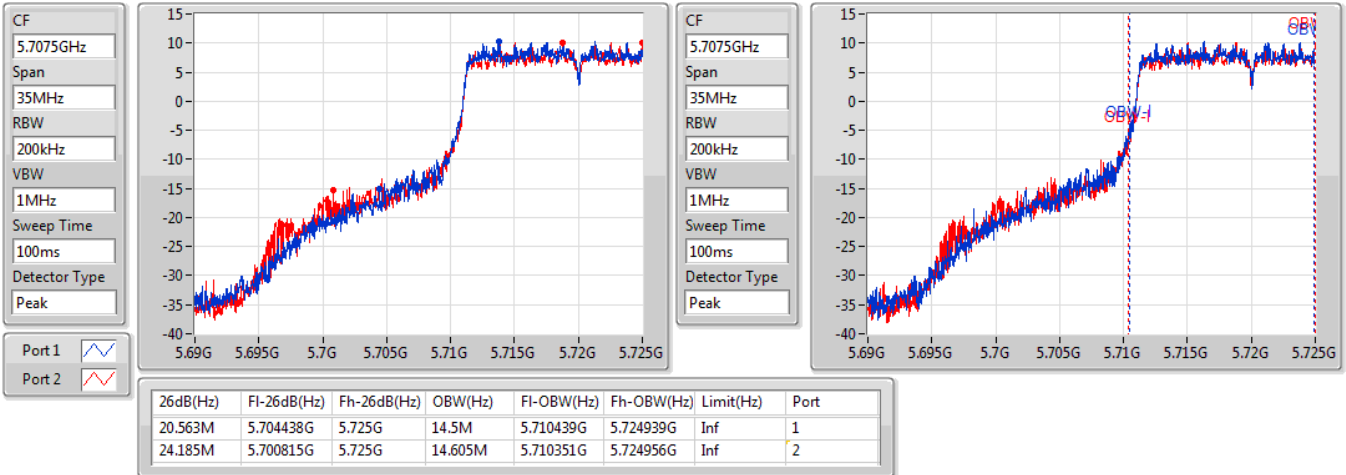

802.11ac VHT20_Nss2,(MCS0)_2TX

EBW

5720MHz Straddle 5.725-5.85GHz

06/01/2020

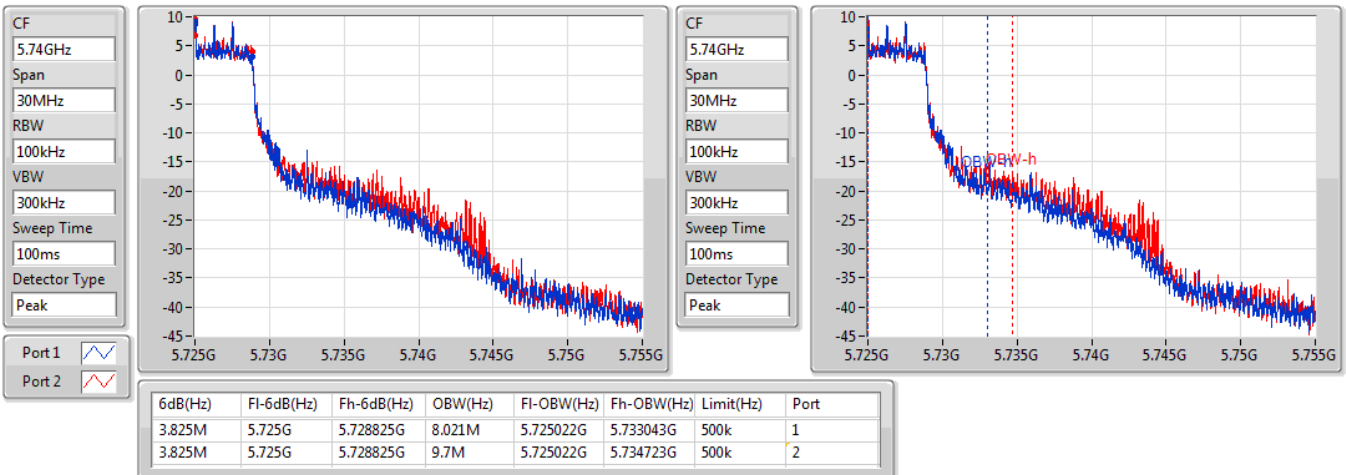

802.11ac VHT40_Nss2,(MCS0)_2TX

EBW

5270MHz

06/01/2020

CF
5.27GHz
Span
120MHz
RBW
500kHz
VBW
2MHz
Sweep Time
100ms
Detector Type
Peak

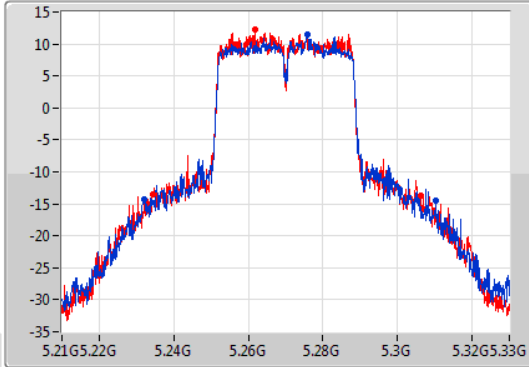

CF
5.27GHz
Span
120MHz
RBW
500kHz
VBW
2MHz
Sweep Time
100ms
Detector Type
Peak

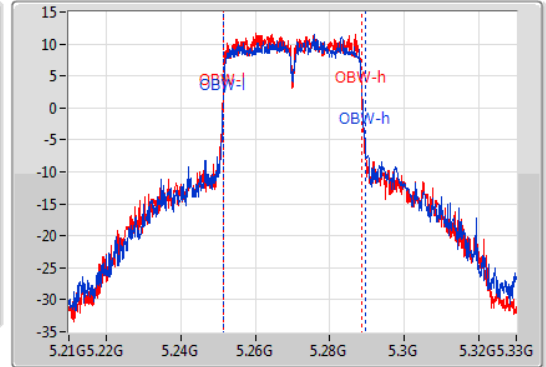

26dB(Hz)	Fl-26dB(Hz)	Fh-26dB(Hz)	OBW(Hz)	Fl-OBW(Hz)	Fh-OBW(Hz)	Limit(Hz)	Port
78.18M	5.23202G	5.3102G	38.261M	5.251289G	5.28955G	Inf	1
71.76M	5.23436G	5.30612G	37.241M	5.251409G	5.288651G	Inf	2

802.11ac VHT40_Nss2,(MCS0)_2TX

EBW

5310MHz

06/01/2020

CF
5.31GHz
Span
120MHz
RBW
500kHz
VBW
2MHz
Sweep Time
100ms
Detector Type
Peak

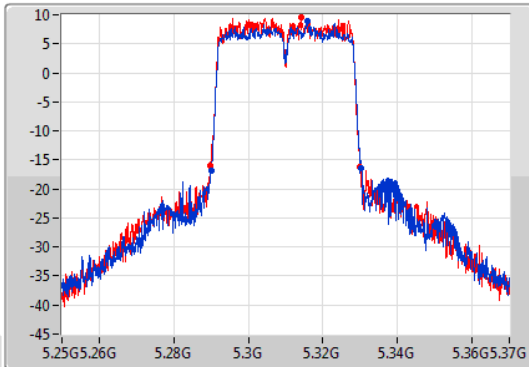

CF
5.31GHz
Span
120MHz
RBW
500kHz
VBW
2MHz
Sweep Time
100ms
Detector Type
Peak

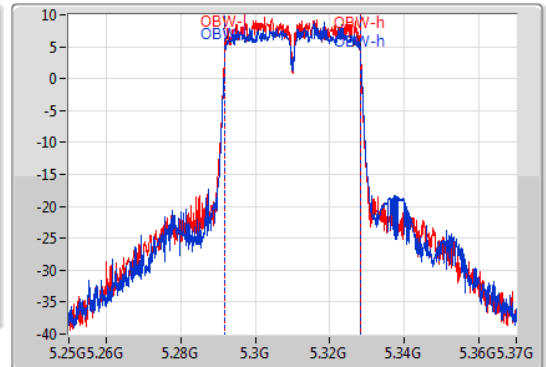

26dB(Hz)	Fl-26dB(Hz)	Fh-26dB(Hz)	OBW(Hz)	Fl-OBW(Hz)	Fh-OBW(Hz)	Limit(Hz)	Port
40.38M	5.28996G	5.33034G	36.522M	5.291829G	5.328351G	Inf	1
40.2M	5.28984G	5.33004G	36.342M	5.291829G	5.328171G	Inf	2

802.11ac VHT40_Nss2,(MCS0)_2TX

EBW

5510MHz

06/01/2020

CF
5.51GHz
Span
120MHz
RBW
500kHz
VBW
2MHz
Sweep Time
100ms
Detector Type
Peak

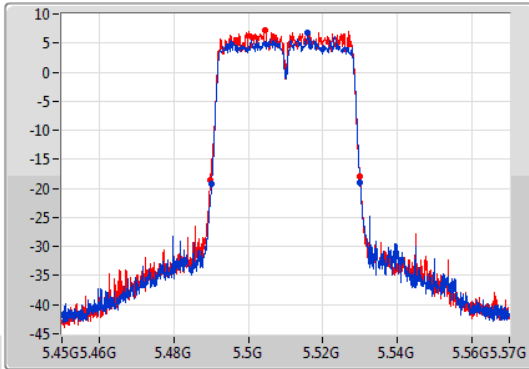

CF
5.51GHz
Span
120MHz
RBW
500kHz
VBW
2MHz
Sweep Time
100ms
Detector Type
Peak

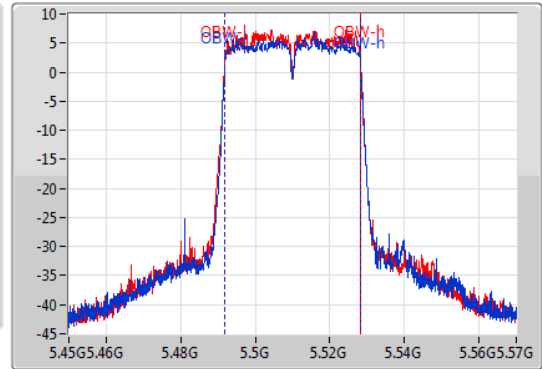

26dB(Hz)	Fl-26dB(Hz)	Fh-26dB(Hz)	OBW(Hz)	Fl-OBW(Hz)	Fh-OBW(Hz)	Limit(Hz)	Port
39.84M	5.49014G	5.52998G	36.402M	5.491889G	5.528291G	Inf	1
40.2M	5.48978G	5.52998G	36.342M	5.491829G	5.528171G	Inf	2

802.11ac VHT40_Nss2,(MCS0)_2TX

EBW

5550MHz

06/01/2020

CF
5.55GHz
Span
120MHz
RBW
500kHz
VBW
2MHz
Sweep Time
100ms
Detector Type
Peak

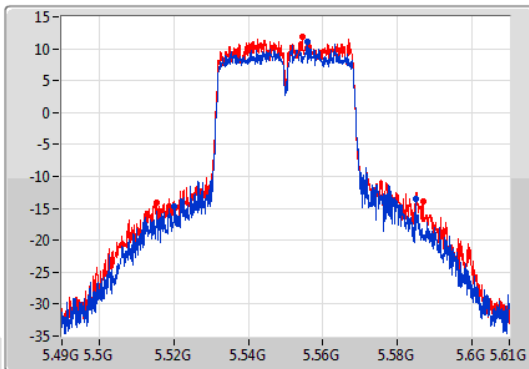

CF
5.55GHz
Span
120MHz
RBW
500kHz
VBW
2MHz
Sweep Time
100ms
Detector Type
Peak

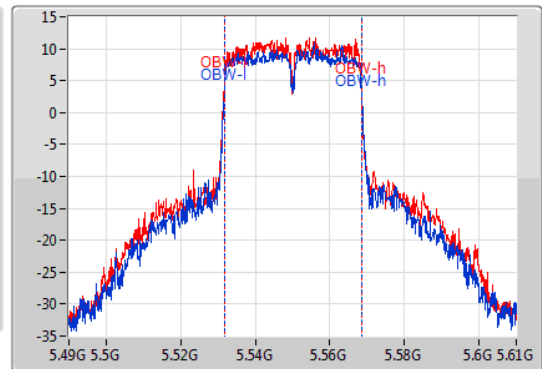

26dB(Hz)	Fl-26dB(Hz)	Fh-26dB(Hz)	OBW(Hz)	Fl-OBW(Hz)	Fh-OBW(Hz)	Limit(Hz)	Port
64.56M	5.52024G	5.5848G	37.001M	5.531649G	5.568651G	Inf	1
71.46M	5.51532G	5.58678G	36.822M	5.531649G	5.568471G	Inf	2

802.11ac VHT40_Nss2,(MCS0)_2TX

EBW

5670MHz

06/01/2020

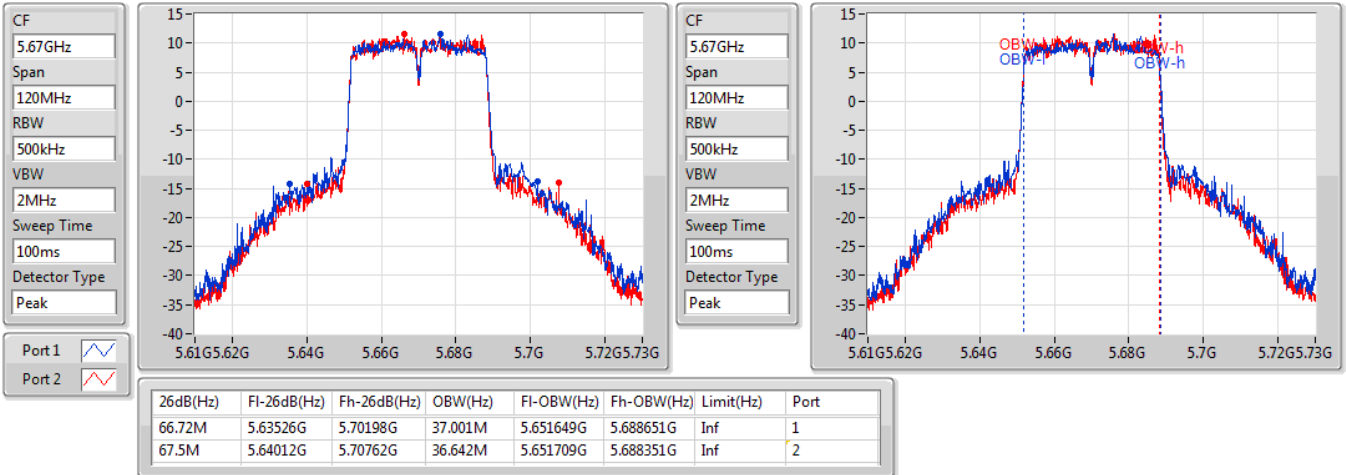

802.11ac VHT40_Nss2,(MCS0)_2TX

EBW

5710MHz Straddle 5.47-5.725GHz

06/01/2020

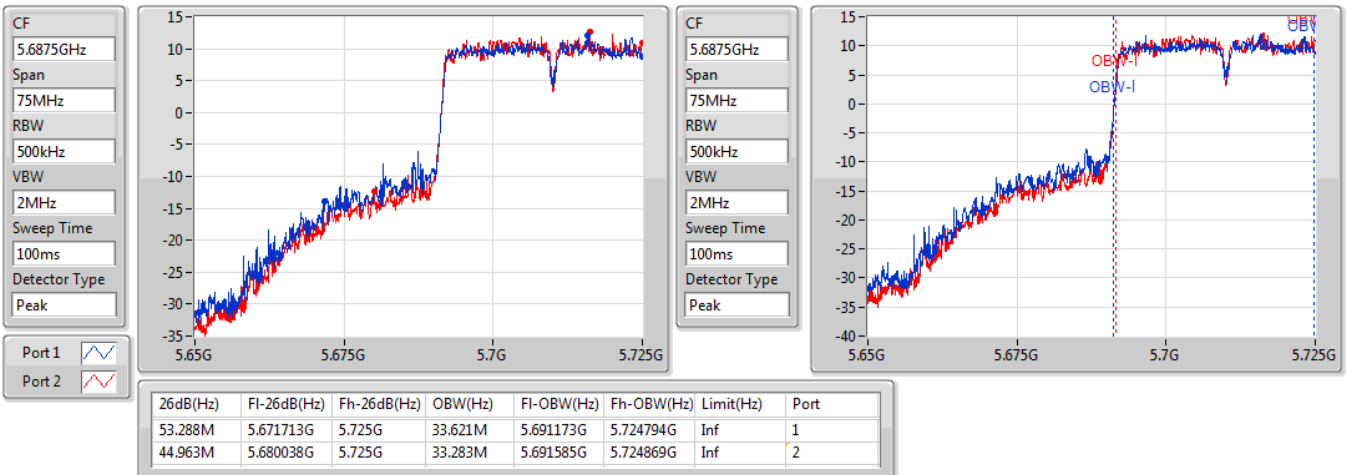

802.11ac VHT40_Nss2,(MCS0)_2TX

EBW

5710MHz Straddle 5.725-5.85GHz

06/01/2020

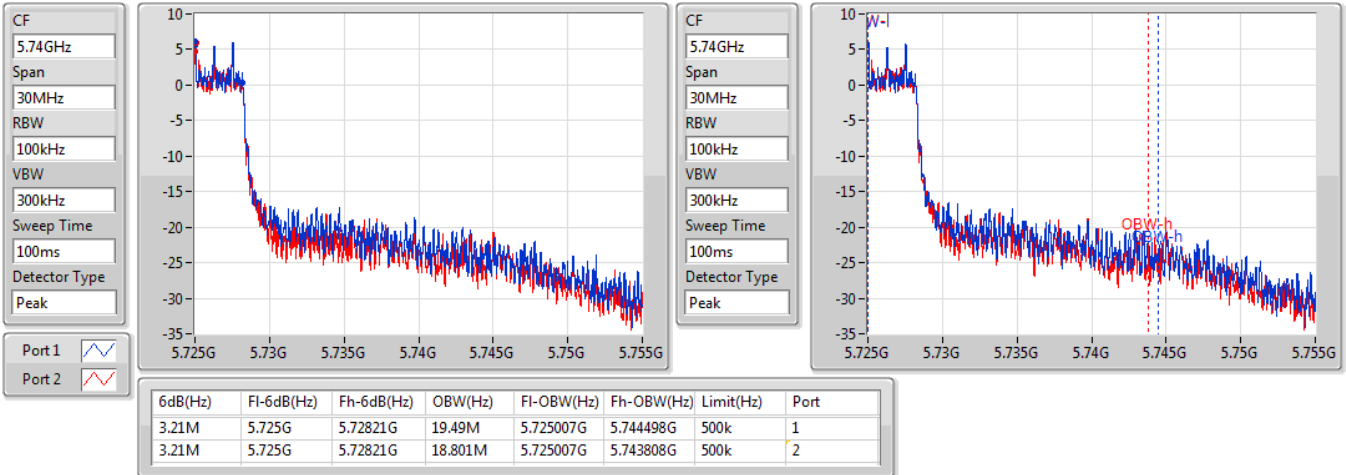

802.11ac VHT80_Nss2,(MCS0)_2TX

EBW

5290MHz

06/01/2020

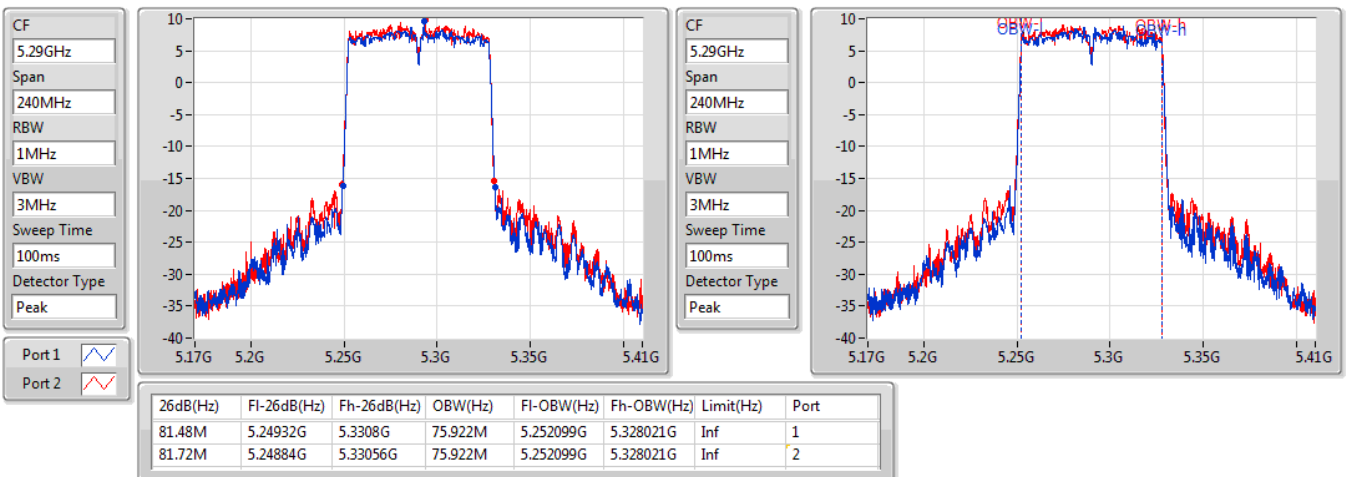

802.11ac VHT80_Nss2,(MCS0)_2TX

EBW

5530MHz

06/01/2020

CF
5.53GHz
Span
240MHz
RBW
1MHz
VBW
3MHz
Sweep Time
100ms
Detector Type
Peak

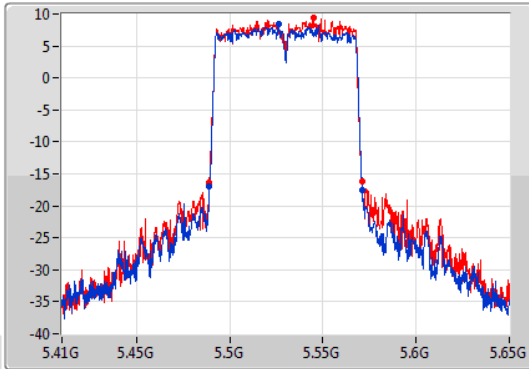

CF
5.53GHz
Span
240MHz
RBW
1MHz
VBW
3MHz
Sweep Time
100ms
Detector Type
Peak

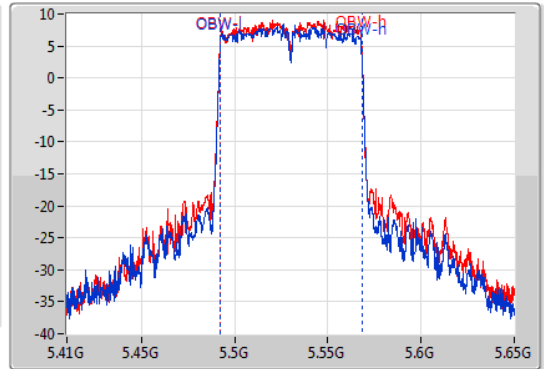

26dB(Hz)	Fl-26dB(Hz)	Fh-26dB(Hz)	OBW(Hz)	Fl-OBW(Hz)	Fh-OBW(Hz)	Limit(Hz)	Port
81.96M	5.4892G	5.57116G	76.042M	5.492099G	5.568141G	Inf	1
81.6M	5.4892G	5.5708G	76.042M	5.492099G	5.568141G	Inf	2

802.11ac VHT80_Nss2,(MCS0)_2TX

EBW

5610MHz

06/01/2020

CF
5.61GHz
Span
240MHz
RBW
1MHz
VBW
3MHz
Sweep Time
100ms
Detector Type
Peak

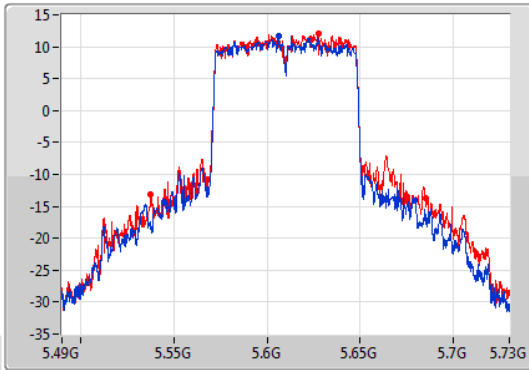

CF
5.61GHz
Span
240MHz
RBW
1MHz
VBW
3MHz
Sweep Time
100ms
Detector Type
Peak

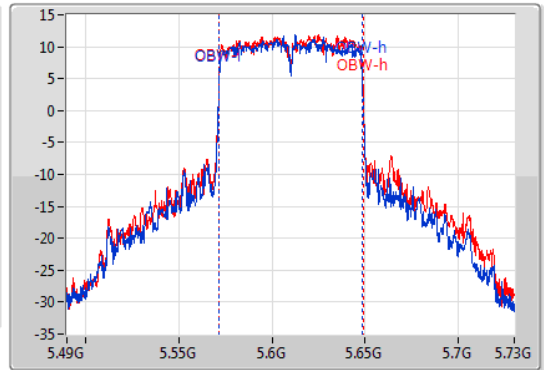

26dB(Hz)	Fl-26dB(Hz)	Fh-26dB(Hz)	OBW(Hz)	Fl-OBW(Hz)	Fh-OBW(Hz)	Limit(Hz)	Port
134.52M	5.54484G	5.67936G	76.642M	5.571739G	5.648381G	Inf	1
147.6M	5.53728G	5.68488G	77.121M	5.571739G	5.648861G	Inf	2

802.11ac VHT80_Nss2,(MCS0)_2TX

EBW

5690MHz Straddle 5.47-5.725GHz

06/01/2020

CF
5.6475GHz
Span
155MHz
RBW
1MHz
VBW
3MHz
Sweep Time
100ms
Detector Type
Peak

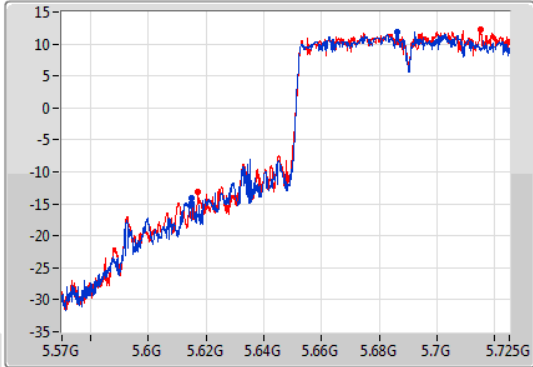

CF
5.6475GHz
Span
155MHz
RBW
1MHz
VBW
3MHz
Sweep Time
100ms
Detector Type
Peak

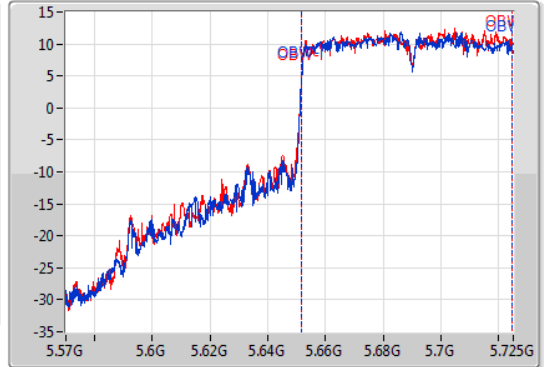

26dB(Hz)	Fl-26dB(Hz)	Fh-26dB(Hz)	OBW(Hz)	Fl-OBW(Hz)	Fh-OBW(Hz)	Limit(Hz)	Port
110.128M	5.614873G	5.725G	72.814M	5.651683G	5.724497G	Inf	1
107.725M	5.617275G	5.725G	72.891M	5.651683G	5.724574G	Inf	2

802.11ac VHT80_Nss2,(MCS0)_2TX

EBW

5690MHz Straddle 5.725-5.85GHz

06/01/2020

CF
5.74GHz
Span
30MHz
RBW
100kHz
VBW
300kHz
Sweep Time
100ms
Detector Type
Peak

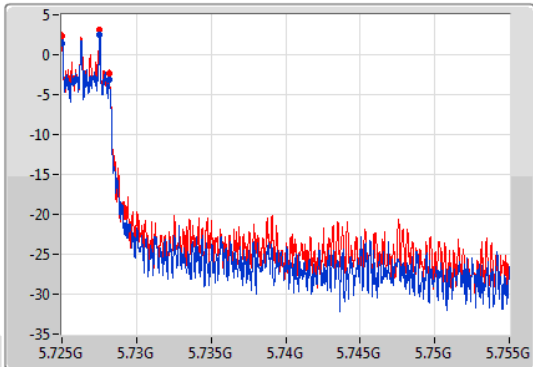

CF
5.74GHz
Span
30MHz
RBW
100kHz
VBW
300kHz
Sweep Time
100ms
Detector Type
Peak

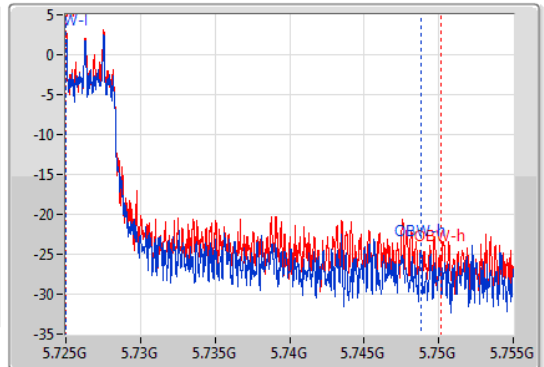

6dB(Hz)	Fl-6dB(Hz)	Fh-6dB(Hz)	OBW(Hz)	Fl-OBW(Hz)	Fh-OBW(Hz)	Limit(Hz)	Port
3.195M	5.725G	5.728195G	23.778M	5.725007G	5.748786G	500k	1
3.195M	5.725G	5.728195G	25.172M	5.725007G	5.75018G	500k	2

802.11ax HEW20_Nss2,(MCS0)_2TX

EBW

5260MHz

06/01/2020

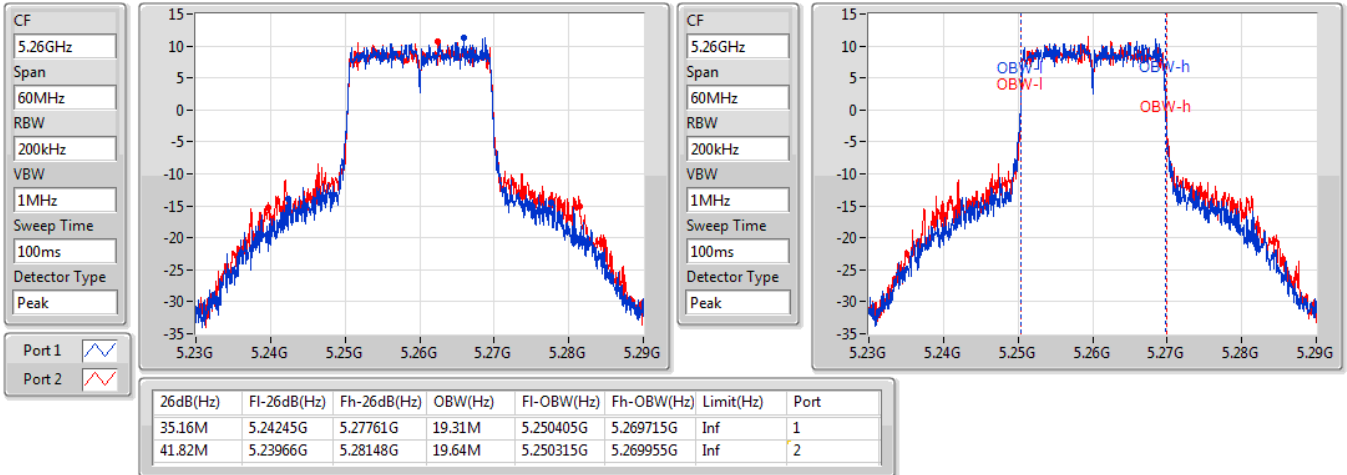

802.11ax HEW20_Nss2,(MCS0)_2TX

EBW

5300MHz

06/01/2020

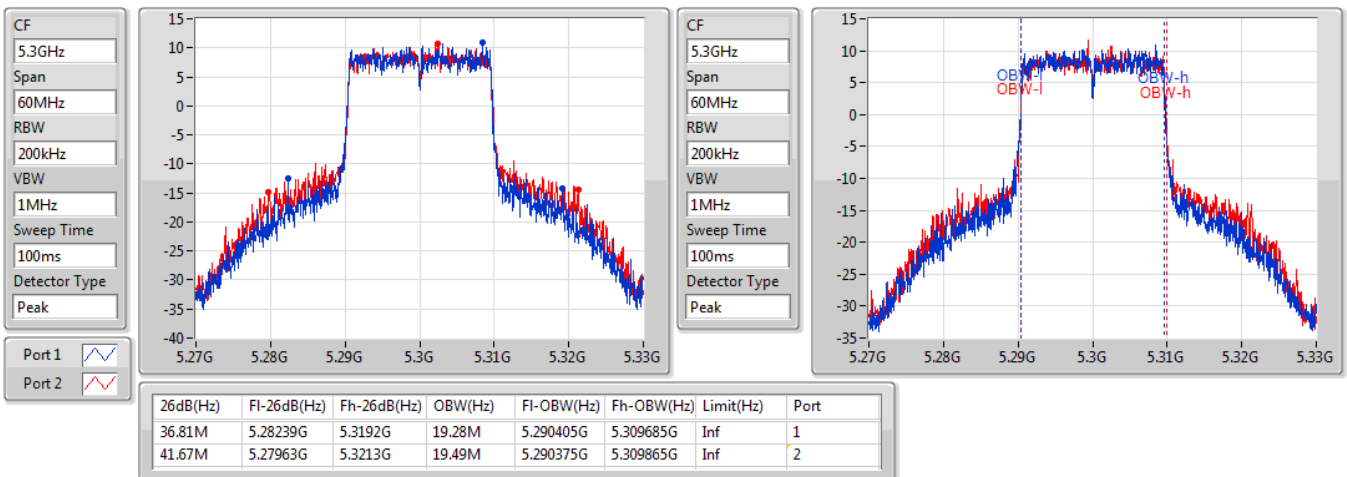

802.11ax HEW20_Nss2,(MCS0)_2TX

EBW

5320MHz

06/01/2020

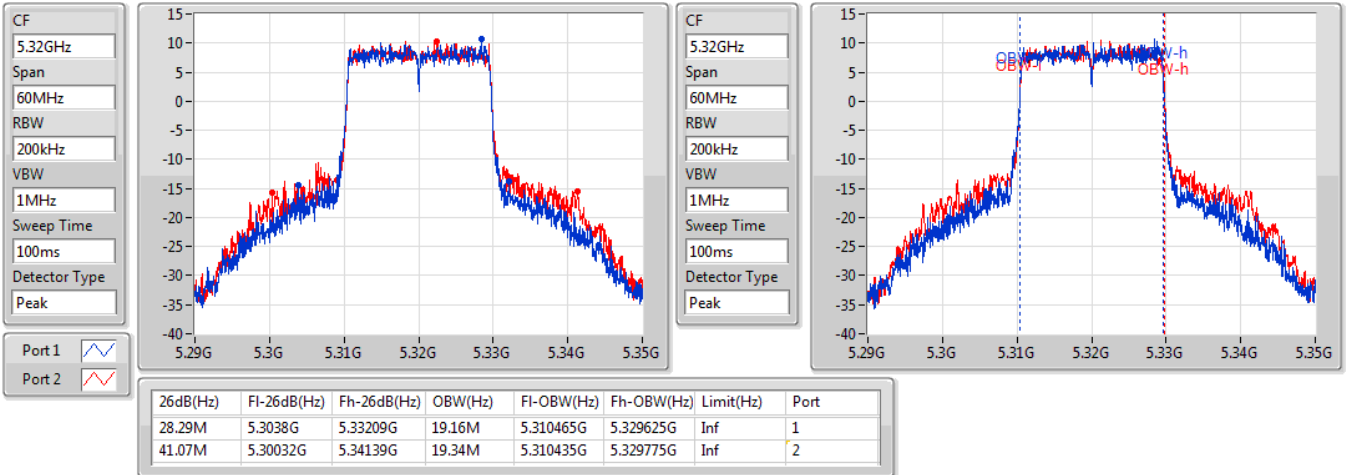

802.11ax HEW20_Nss2,(MCS0)_2TX

EBW

5500MHz

06/01/2020

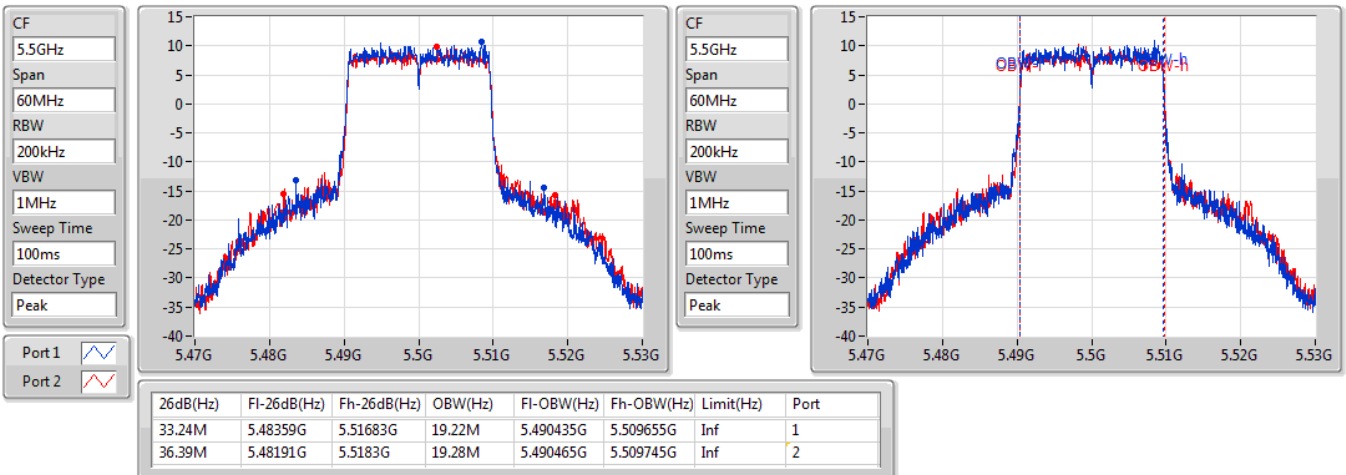

802.11ax HEW20_Nss2,(MCS0)_2TX

EBW

5580MHz

06/01/2020

CF
5.58GHz
Span
60MHz
RBW
200kHz
VBW
1MHz
Sweep Time
100ms
Detector Type
Peak

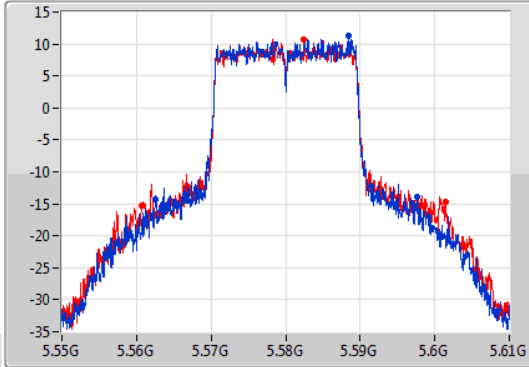

CF
5.58GHz
Span
60MHz
RBW
200kHz
VBW
1MHz
Sweep Time
100ms
Detector Type
Peak

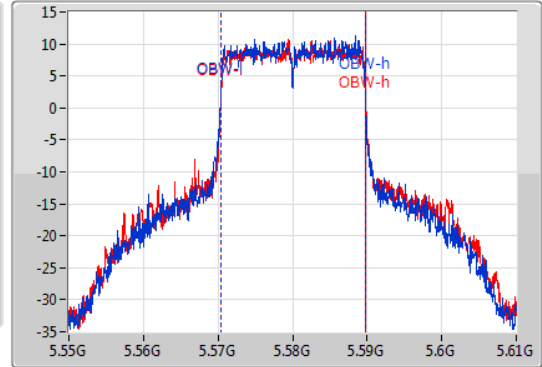

26dB(Hz)	Fl-26dB(Hz)	Fh-26dB(Hz)	OBW(Hz)	Fl-OBW(Hz)	Fh-OBW(Hz)	Limit(Hz)	Port
35.13M	5.56251G	5.59764G	19.31M	5.570405G	5.589715G	Inf	1
40.71M	5.56071G	5.60142G	19.43M	5.570405G	5.589835G	Inf	2

802.11ax HEW20_Nss2,(MCS0)_2TX

EBW

5700MHz

06/01/2020

CF
5.7GHz
Span
60MHz
RBW
200kHz
VBW
1MHz
Sweep Time
100ms
Detector Type
Peak

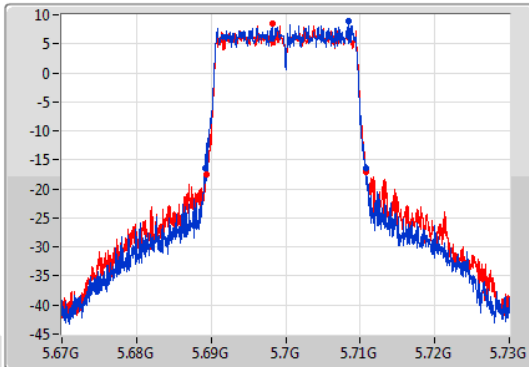

CF
5.7GHz
Span
60MHz
RBW
200kHz
VBW
1MHz
Sweep Time
100ms
Detector Type
Peak

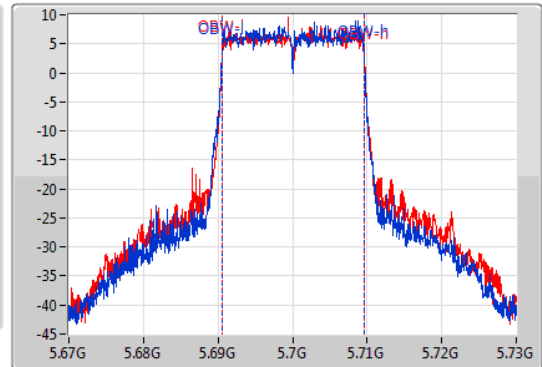

26dB(Hz)	Fl-26dB(Hz)	Fh-26dB(Hz)	OBW(Hz)	Fl-OBW(Hz)	Fh-OBW(Hz)	Limit(Hz)	Port
21.63M	5.68917G	5.7108G	19.04M	5.690525G	5.709565G	Inf	1
21.33M	5.68944G	5.71077G	19.1M	5.690555G	5.709655G	Inf	2

802.11ax HEW20_Nss2,(MCS0)_2TX

EBW

5720MHz Straddle 5.47-5.725GHz

06/01/2020

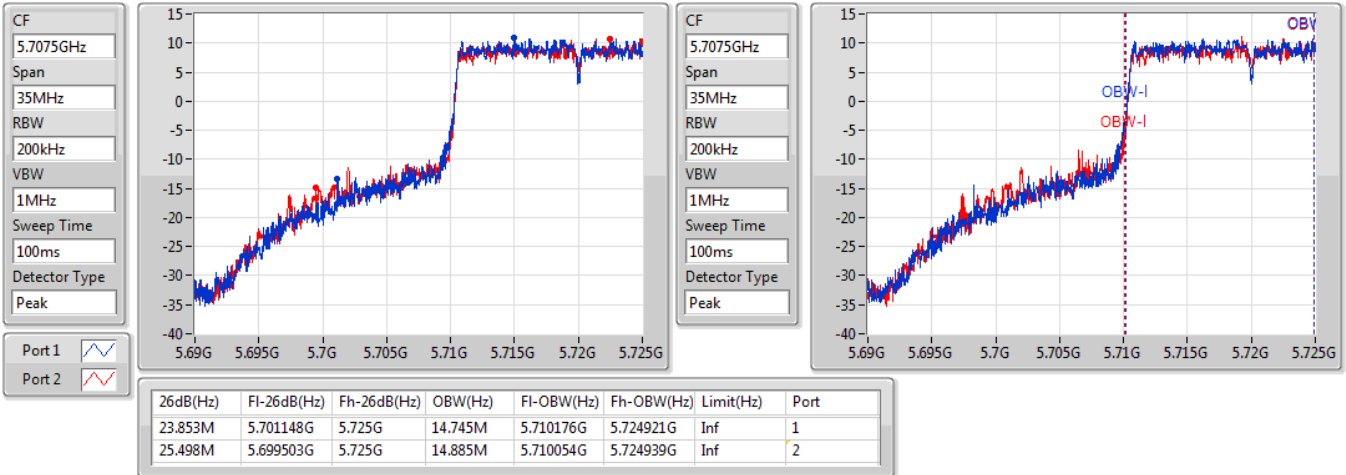

802.11ax HEW20_Nss2,(MCS0)_2TX

EBW

5720MHz Straddle 5.725-5.85GHz

06/01/2020

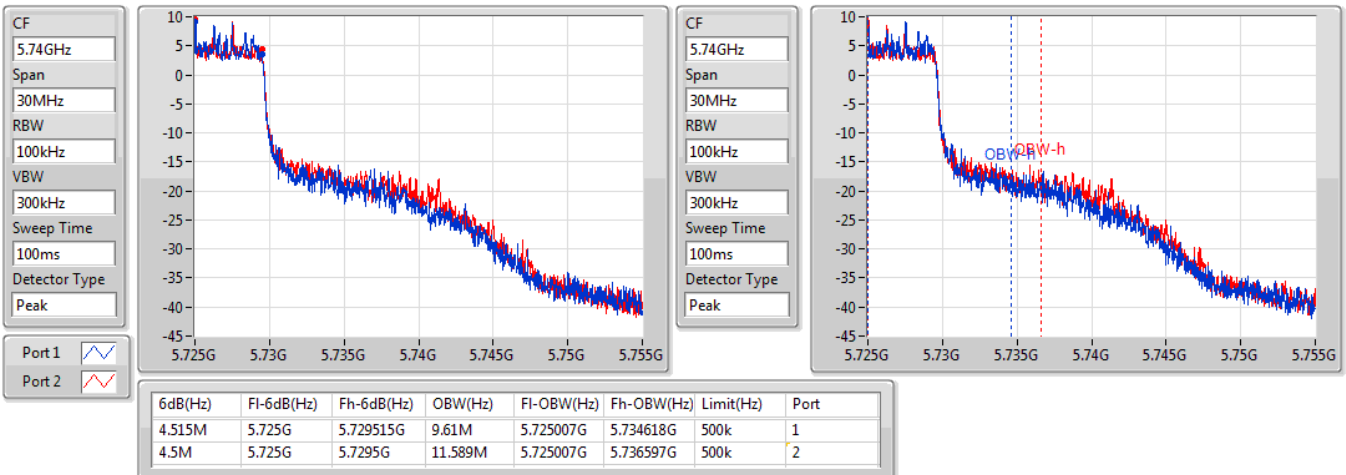

802.11ax HEW40_Nss2,(MCS0)_2TX

EBW

5270MHz

06/01/2020

CF
5.27GHz
Span
120MHz
RBW
500kHz
VBW
2MHz
Sweep Time
100ms
Detector Type
Peak

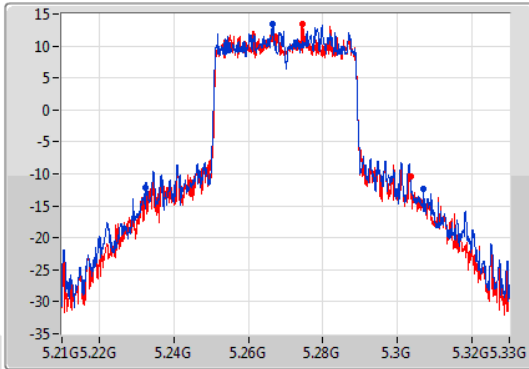

CF
5.27GHz
Span
120MHz
RBW
500kHz
VBW
2MHz
Sweep Time
100ms
Detector Type
Peak

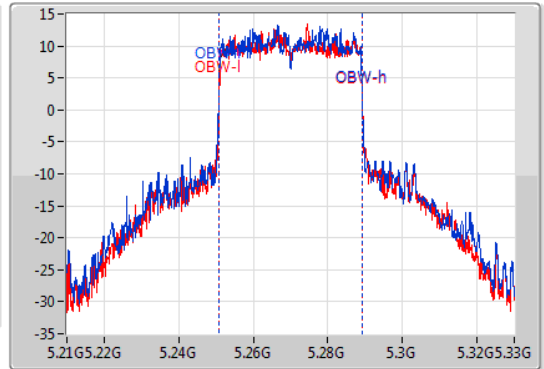

26dB(Hz)	Fl-26dB(Hz)	Fh-26dB(Hz)	OBW(Hz)	Fl-OBW(Hz)	Fh-OBW(Hz)	Limit(Hz)	Port
74.52M	5.23232G	5.30684G	38.381M	5.25087G	5.28925G	Inf	1
71.1M	5.23238G	5.30348G	38.381M	5.25093G	5.28931G	Inf	2

802.11ax HEW40_Nss2,(MCS0)_2TX

EBW

5310MHz

06/01/2020

CF
5.31GHz
Span
120MHz
RBW
500kHz
VBW
2MHz
Sweep Time
100ms
Detector Type
Peak

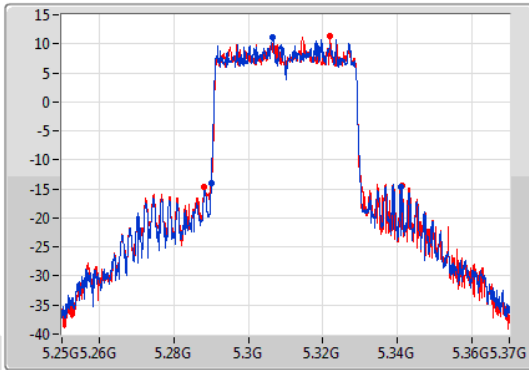

CF
5.31GHz
Span
120MHz
RBW
500kHz
VBW
2MHz
Sweep Time
100ms
Detector Type
Peak

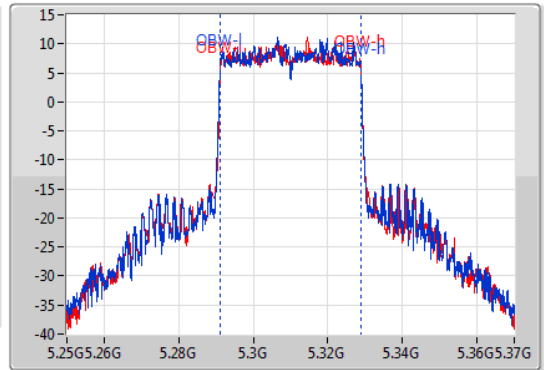

26dB(Hz)	Fl-26dB(Hz)	Fh-26dB(Hz)	OBW(Hz)	Fl-OBW(Hz)	Fh-OBW(Hz)	Limit(Hz)	Port
51M	5.29002G	5.34102G	37.781M	5.291109G	5.328891G	Inf	1
52.92M	5.28822G	5.34114G	37.721M	5.291169G	5.328891G	Inf	2

802.11ax HEW40_Nss2,(MCS0)_2TX

EBW

5510MHz

06/01/2020

CF
5.51GHz
Span
120MHz
RBW
500kHz
VBW
2MHz
Sweep Time
100ms
Detector Type
Peak

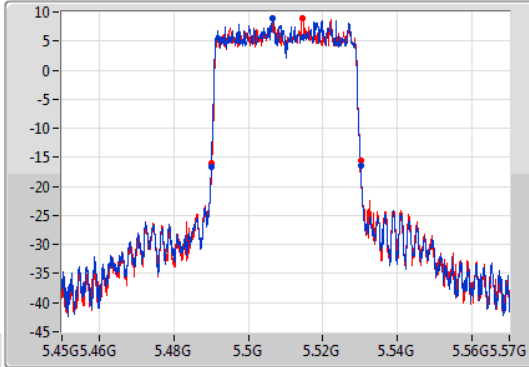

CF
5.51GHz
Span
120MHz
RBW
500kHz
VBW
2MHz
Sweep Time
100ms
Detector Type
Peak

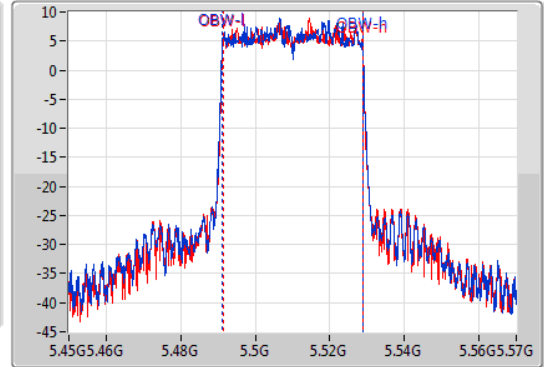

26dB(Hz)	Fl-26dB(Hz)	Fh-26dB(Hz)	OBW(Hz)	Fl-OBW(Hz)	Fh-OBW(Hz)	Limit(Hz)	Port
40.08M	5.49002G	5.5301G	37.721M	5.491109G	5.528831G	Inf	1
39.96M	5.4902G	5.53016G	37.541M	5.491289G	5.528831G	Inf	2

802.11ax HEW40_Nss2,(MCS0)_2TX

EBW

5550MHz

06/01/2020

CF
5.55GHz
Span
120MHz
RBW
500kHz
VBW
2MHz
Sweep Time
100ms
Detector Type
Peak

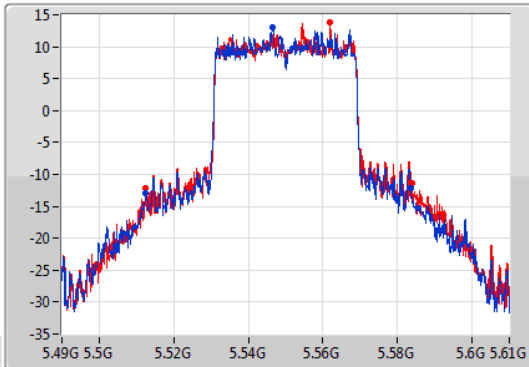

CF
5.55GHz
Span
120MHz
RBW
500kHz
VBW
2MHz
Sweep Time
100ms
Detector Type
Peak

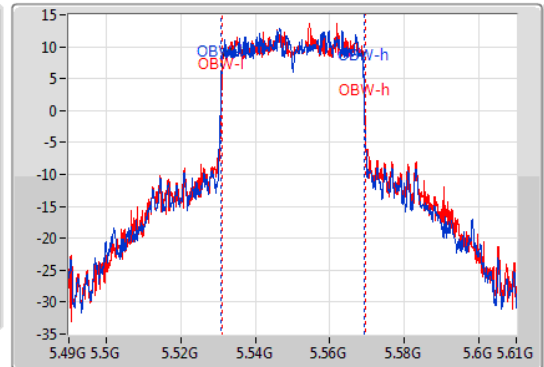

26dB(Hz)	Fl-26dB(Hz)	Fh-26dB(Hz)	OBW(Hz)	Fl-OBW(Hz)	Fh-OBW(Hz)	Limit(Hz)	Port
71.22M	5.51238G	5.5836G	38.201M	5.53093G	5.56913G	Inf	1
71.52M	5.51244G	5.58396G	38.441M	5.53099G	5.56943G	Inf	2

802.11ax HEW40_Nss2,(MCS0)_2TX

EBW

5670MHz

06/01/2020

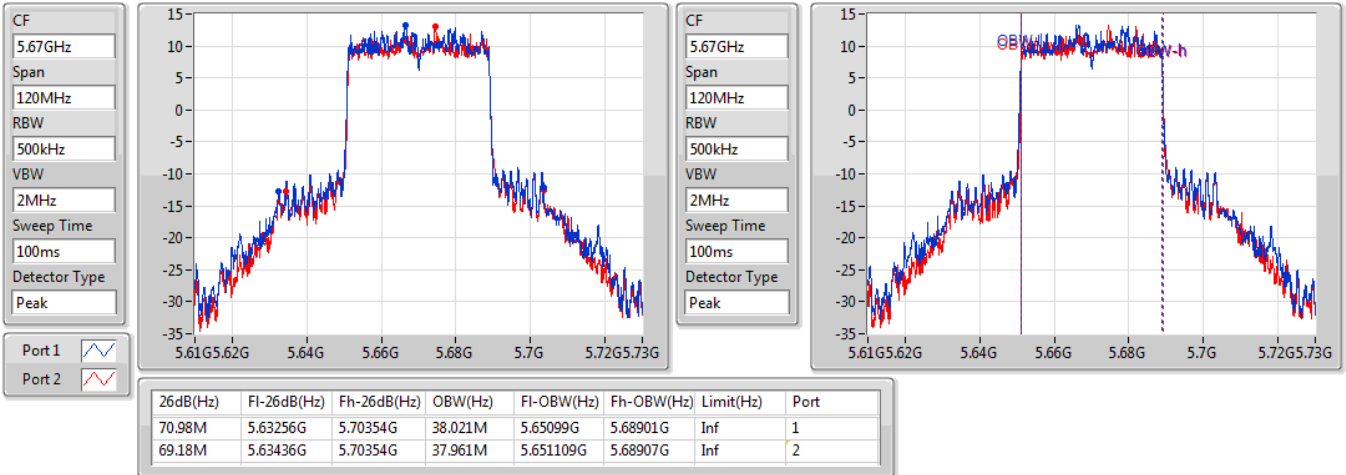

802.11ax HEW40_Nss2,(MCS0)_2TX

EBW

5710MHz Straddle 5.47-5.725GHz

06/01/2020

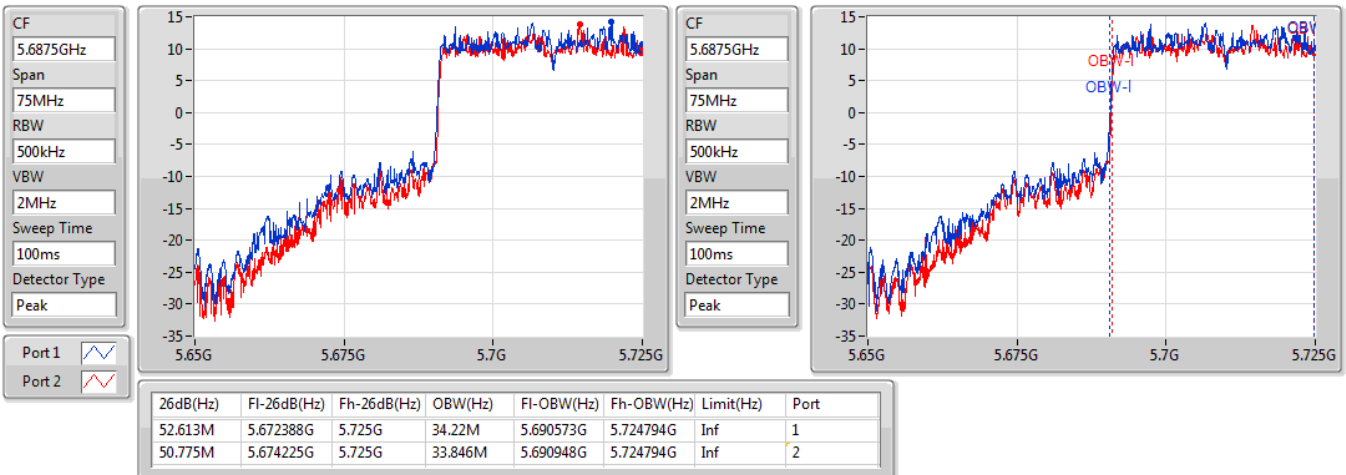

802.11ax HEW40_Nss2,(MCS0)_2TX

EBW

5710MHz Straddle 5.725-5.85GHz

06/01/2020

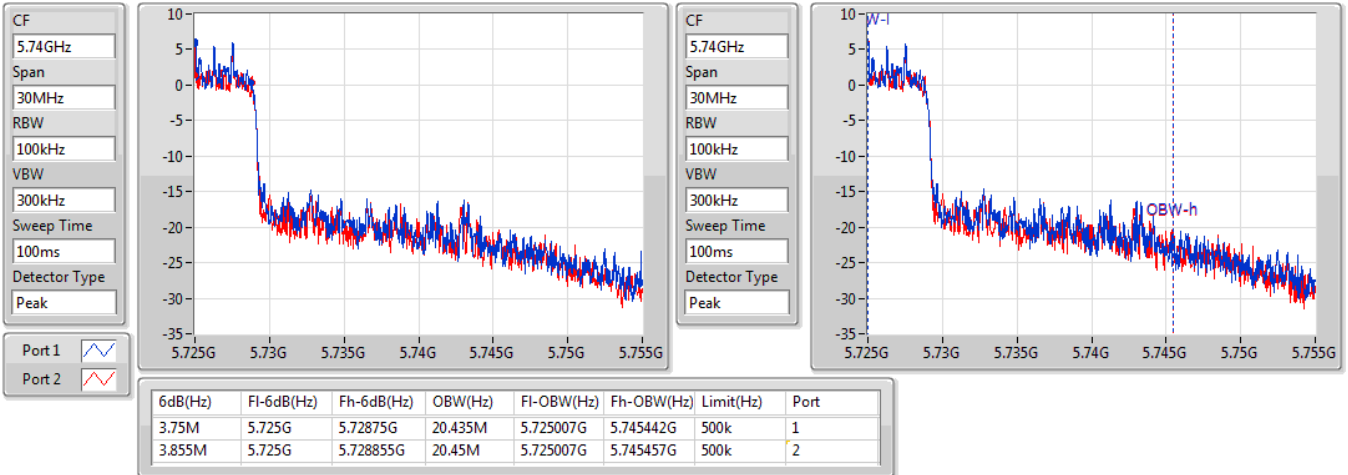

802.11ax HEW80_Nss2,(MCS0)_2TX

EBW

5290MHz

06/01/2020

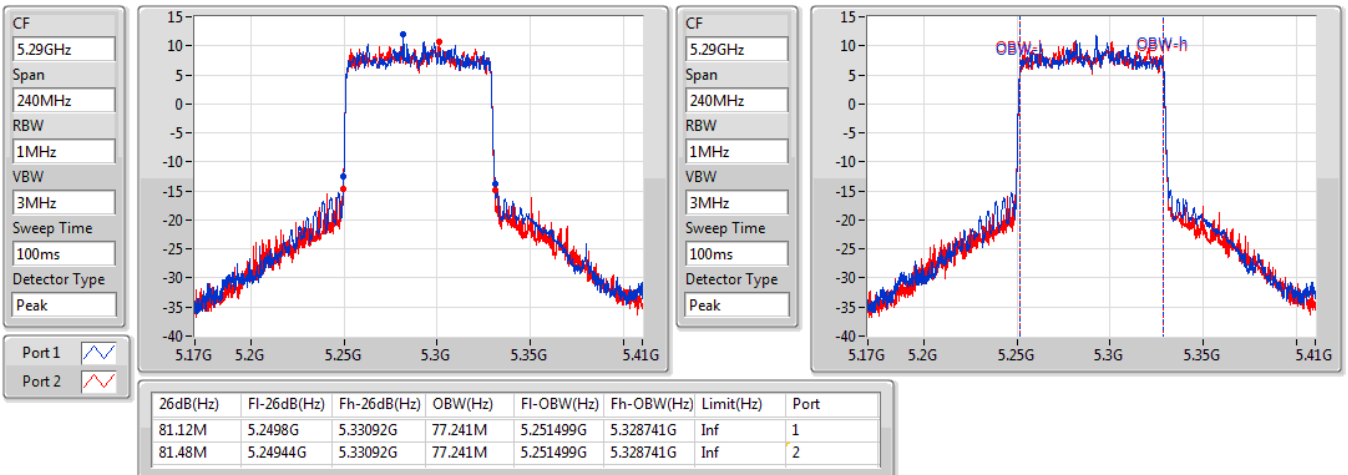

802.11ax HEW80_Nss2,(MCS0)_2TX

EBW

5530MHz

06/01/2020

CF
5.53GHz
Span
240MHz
RBW
1MHz
VBW
3MHz
Sweep Time
100ms
Detector Type
Peak

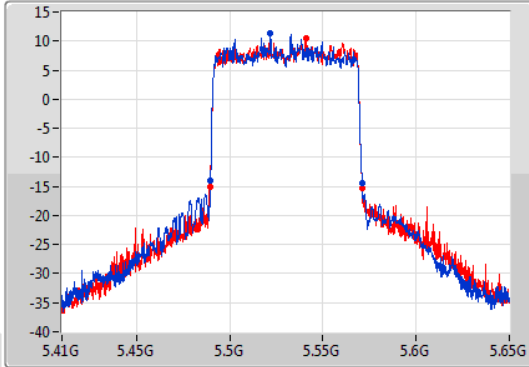

CF
5.53GHz
Span
240MHz
RBW
1MHz
VBW
3MHz
Sweep Time
100ms
Detector Type
Peak

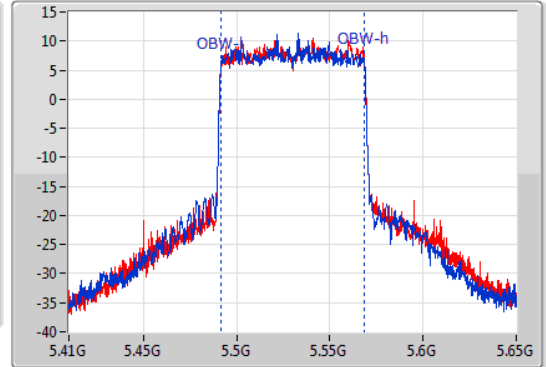

26dB(Hz)	Fl-26dB(Hz)	Fh-26dB(Hz)	OBW(Hz)	Fl-OBW(Hz)	Fh-OBW(Hz)	Limit(Hz)	Port
81.36M	5.48968G	5.57104G	77.241M	5.491499G	5.568741G	Inf	1
81.72M	5.48932G	5.57104G	77.241M	5.491499G	5.568741G	Inf	2

802.11ax HEW80_Nss2,(MCS0)_2TX

EBW

5610MHz

06/01/2020

CF
5.61GHz
Span
240MHz
RBW
1MHz
VBW
3MHz
Sweep Time
100ms
Detector Type
Peak

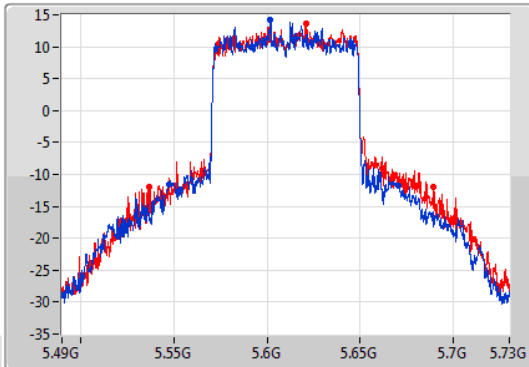

CF
5.61GHz
Span
240MHz
RBW
1MHz
VBW
3MHz
Sweep Time
100ms
Detector Type
Peak

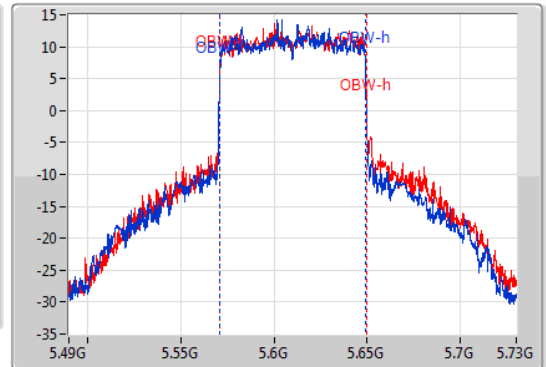

26dB(Hz)	Fl-26dB(Hz)	Fh-26dB(Hz)	OBW(Hz)	Fl-OBW(Hz)	Fh-OBW(Hz)	Limit(Hz)	Port
123M	5.54736G	5.67036G	77.841M	5.571139G	5.648981G	Inf	1
152.04M	5.53704G	5.68908G	78.561M	5.571139G	5.6497G	Inf	2

802.11ax HEW80_Nss2,(MCS0)_2TX

EBW

5690MHz Straddle 5.47-5.725GHz

06/01/2020

CF
5.6475GHz
Span
155MHz
RBW
1MHz
VBW
3MHz
Sweep Time
100ms
Detector Type
Peak

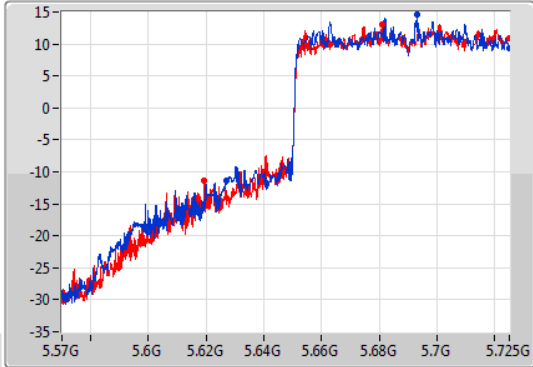

CF
5.6475GHz
Span
155MHz
RBW
1MHz
VBW
3MHz
Sweep Time
100ms
Detector Type
Peak

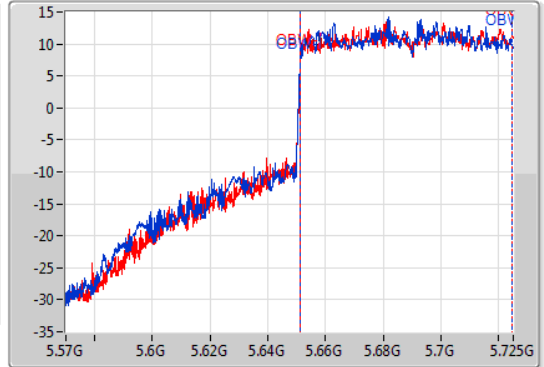

26dB(Hz)	Fl-26dB(Hz)	Fh-26dB(Hz)	OBW(Hz)	Fl-OBW(Hz)	Fh-OBW(Hz)	Limit(Hz)	Port
97.883M	5.627118G	5.725G	73.356M	5.651141G	5.724497G	Inf	1
105.633M	5.619368G	5.725G	73.511M	5.651141G	5.724651G	Inf	2

802.11ax HEW80_Nss2,(MCS0)_2TX

EBW

5690MHz Straddle 5.725-5.85GHz

06/01/2020

CF
5.74GHz
Span
30MHz
RBW
100kHz
VBW
300kHz
Sweep Time
100ms
Detector Type
Peak

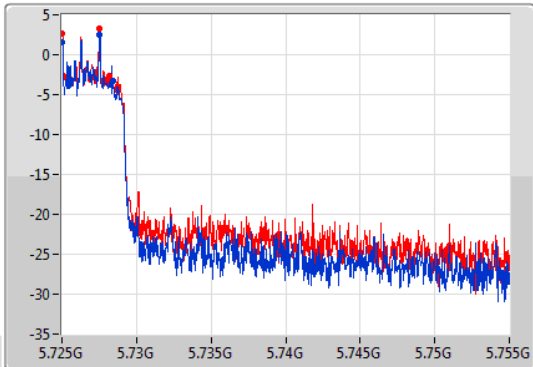

CF
5.74GHz
Span
30MHz
RBW
100kHz
VBW
300kHz
Sweep Time
100ms
Detector Type
Peak

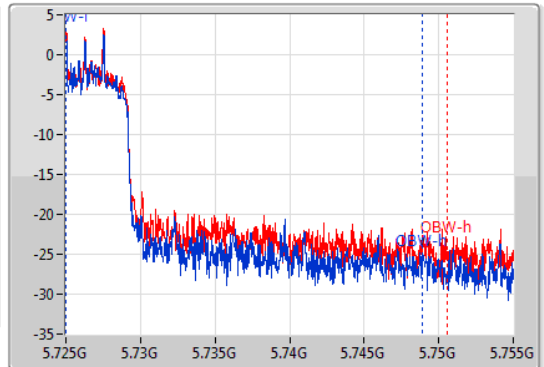

6dB(Hz)	Fl-6dB(Hz)	Fh-6dB(Hz)	OBW(Hz)	Fl-OBW(Hz)	Fh-OBW(Hz)	Limit(Hz)	Port
3.42M	5.725G	5.72842G	23.883M	5.725007G	5.748891G	500k	1
3.165M	5.725G	5.728165G	25.532M	5.725007G	5.75054G	500k	2



Summary

Mode	Max-N dB (Hz)	Max-OBW (Hz)	ITU-Code	Min-N dB (Hz)	Min-OBW (Hz)
5.25-5.35GHz	-	-	-	-	-
802.11a_Nss1,(6Mbps)_1TX	37.71M	19.19M	19M2D1D	37.56M	18.321M
802.11ac VHT20_Nss1,(MCS0)_1TX	38.73M	18.831M	18M8D1D	24.96M	18.021M
802.11ac VHT40_Nss1,(MCS0)_1TX	79.98M	38.861M	38M9D1D	50.88M	36.642M
802.11ac VHT80_Nss1,(MCS0)_1TX	115.2M	76.162M	76M2D1D	115.2M	76.162M
802.11ax HEW20_Nss1,(MCS0)_1TX	41.01M	19.67M	19M7D1D	26.73M	19.13M
802.11ax HEW40_Nss1,(MCS0)_1TX	74.22M	38.321M	38M3D1D	48.9M	37.721M
802.11ax HEW80_Nss1,(MCS0)_1TX	82.68M	77.361M	77M4D1D	82.68M	77.361M
5.47-5.725GHz	-	-	-	-	-
802.11a_Nss1,(6Mbps)_1TX	37.65M	19.13M	19M1D1D	21.15M	14.57M
802.11ac VHT20_Nss1,(MCS0)_1TX	36.24M	18.711M	18M7D1D	21.403M	14.22M
802.11ac VHT40_Nss1,(MCS0)_1TX	84.6M	39.76M	39M8D1D	40.44M	34.07M
802.11ac VHT80_Nss1,(MCS0)_1TX	158.64M	77.001M	77M0D1D	82.08M	73.356M
802.11ax HEW20_Nss1,(MCS0)_1TX	40.98M	19.82M	19M8D1D	21.45M	14.71M
802.11ax HEW40_Nss1,(MCS0)_1TX	83.76M	39.04M	39M0D1D	39.96M	34.07M
802.11ax HEW80_Nss1,(MCS0)_1TX	151.68M	78.561M	78M6D1D	82.32M	73.821M
5.725-5.85GHz	-	-	-	-	-
802.11a_Nss1,(6Mbps)_1TX	3.225M	9.685M	9M69D1D	3.225M	9.685M
802.11ac VHT20_Nss1,(MCS0)_1TX	3.855M	8.141M	8M14D1D	3.855M	8.141M
802.11ac VHT40_Nss1,(MCS0)_1TX	3.21M	20.315M	20M3D1D	3.21M	20.315M
802.11ac VHT80_Nss1,(MCS0)_1TX	3.195M	25.772M	25M8D1D	3.195M	25.772M
802.11ax HEW20_Nss1,(MCS0)_1TX	4.545M	9.565M	9M57D1D	4.545M	9.565M
802.11ax HEW40_Nss1,(MCS0)_1TX	3.825M	21.634M	21M6D1D	3.825M	21.634M
802.11ax HEW80_Nss1,(MCS0)_1TX	3.36M	27.106M	27M1D1D	3.36M	27.106M

Max-N dB = Maximum 6dB down bandwidth for 5.725-5.85GHz band / Maximum 26dB down bandwidth for other band;

Max-OBW = Maximum 99% occupied bandwidth;

Min-N dB = Minimum 6dB down bandwidth for 5.725-5.85GHz band / Maximum 26dB down bandwidth for other band;

Min-OBW = Minimum 99% occupied bandwidth;



Result

Mode	Result	Limit (Hz)	Port 1-N dB (Hz)	Port 1-OBW (Hz)
802.11a_Nss1,(6Mbps)_1TX	-	-	-	-
5260MHz	Pass	Inf	37.62M	18.321M
5300MHz	Pass	Inf	37.56M	18.801M
5320MHz	Pass	Inf	37.71M	19.19M
5500MHz	Pass	Inf	21.15M	16.762M
5580MHz	Pass	Inf	37.65M	19.13M
5700MHz	Pass	Inf	21.69M	16.762M
5720MHz Straddle 5.47-5.725GHz	Pass	Inf	23.608M	14.57M
5720MHz Straddle 5.725-5.85GHz	Pass	500k	3.225M	9.685M
802.11ac VHT20_Nss1,(MCS0)_1TX	-	-	-	-
5260MHz	Pass	Inf	35.94M	18.681M
5300MHz	Pass	Inf	38.73M	18.831M
5320MHz	Pass	Inf	24.96M	18.021M
5500MHz	Pass	Inf	21.42M	17.901M
5580MHz	Pass	Inf	36.24M	18.711M
5700MHz	Pass	Inf	21.45M	17.871M
5720MHz Straddle 5.47-5.725GHz	Pass	Inf	21.403M	14.22M
5720MHz Straddle 5.725-5.85GHz	Pass	500k	3.855M	8.141M
802.11ac VHT40_Nss1,(MCS0)_1TX	-	-	-	-
5270MHz	Pass	Inf	79.98M	38.861M
5310MHz	Pass	Inf	50.88M	36.642M
5510MHz	Pass	Inf	40.44M	36.522M
5550MHz	Pass	Inf	81.78M	39.46M
5670MHz	Pass	Inf	84.6M	39.76M
5710MHz Straddle 5.47-5.725GHz	Pass	Inf	52.5M	34.07M
5710MHz Straddle 5.725-5.85GHz	Pass	500k	3.21M	20.315M
802.11ac VHT80_Nss1,(MCS0)_1TX	-	-	-	-
5290MHz	Pass	Inf	115.2M	76.162M
5530MHz	Pass	Inf	82.08M	75.802M
5610MHz	Pass	Inf	158.64M	77.001M
5690MHz Straddle 5.47-5.725GHz	Pass	Inf	115.32M	73.356M
5690MHz Straddle 5.725-5.85GHz	Pass	500k	3.195M	25.772M
802.11ax HEW20_Nss1,(MCS0)_1TX	-	-	-	-
5260MHz	Pass	Inf	41.01M	19.43M
5300MHz	Pass	Inf	41.01M	19.67M
5320MHz	Pass	Inf	26.73M	19.13M
5500MHz	Pass	Inf	22.44M	19.04M
5580MHz	Pass	Inf	40.98M	19.82M
5700MHz	Pass	Inf	21.45M	19.01M
5720MHz Straddle 5.47-5.725GHz	Pass	Inf	25.288M	14.71M
5720MHz Straddle 5.725-5.85GHz	Pass	500k	4.545M	9.565M
802.11ax HEW40_Nss1,(MCS0)_1TX	-	-	-	-
5270MHz	Pass	Inf	74.22M	38.321M
5310MHz	Pass	Inf	48.9M	37.721M



Mode	Result	Limit (Hz)	Port 1-N dB (Hz)	Port 1-OBW (Hz)
5510MHz	Pass	Inf	39.96M	37.601M
5550MHz	Pass	Inf	83.76M	39.04M
5670MHz	Pass	Inf	73.32M	38.561M
5710MHz Straddle 5.47-5.725GHz	Pass	Inf	52.8M	34.07M
5710MHz Straddle 5.725-5.85GHz	Pass	500k	3.825M	21.634M
802.11ax HEW80_Nss1,(MCS0)_1TX	-	-	-	-
5290MHz	Pass	Inf	82.68M	77.361M
5530MHz	Pass	Inf	82.32M	77.241M
5610MHz	Pass	Inf	151.68M	78.561M
5690MHz Straddle 5.47-5.725GHz	Pass	Inf	118.653M	73.821M
5690MHz Straddle 5.725-5.85GHz	Pass	500k	3.36M	27.106M

Port X-N dB = Port X 6dB down bandwidth for 5.725-5.85GHz band / 26dB down bandwidth for other band

Port X-OBW = Port X 99% occupied bandwidth;

802.11a_Nss1,(6Mbps)_1TX

EBW

5260MHz

06/01/2020

CF
5.26GHz
Span
60MHz
RBW
200kHz
VBW
1MHz
Sweep Time
100ms
Detector Type
Peak
Port1

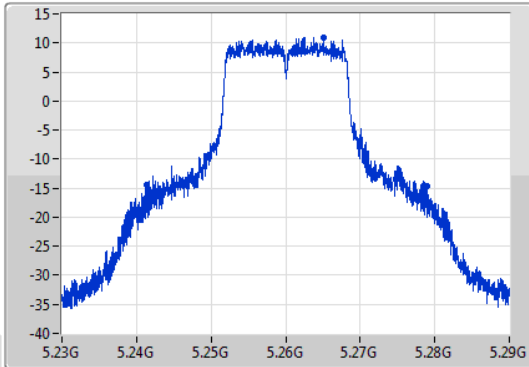

CF
5.26GHz
Span
60MHz
RBW
200kHz
VBW
1MHz
Sweep Time
100ms
Detector Type
Peak

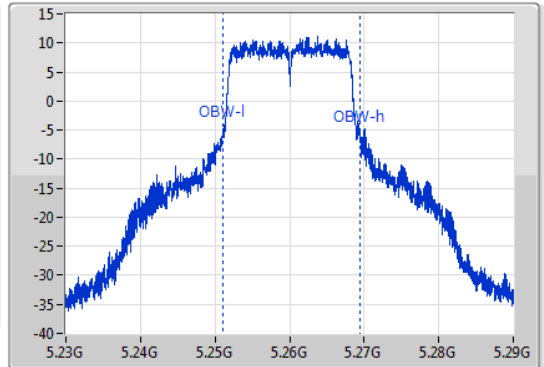

26dB(Hz)	Fl-26dB(Hz)	Fh-26dB(Hz)	OBW(Hz)	Fl-OBW(Hz)	Fh-OBW(Hz)	Limit(Hz)	Port
37.62M	5.24137G	5.27899G	18.321M	5.251064G	5.269385G	Inf	1

802.11a_Nss1,(6Mbps)_1TX

EBW

5300MHz

06/01/2020

CF
5.3GHz
Span
60MHz
RBW
200kHz
VBW
1MHz
Sweep Time
100ms
Detector Type
Peak
Port1

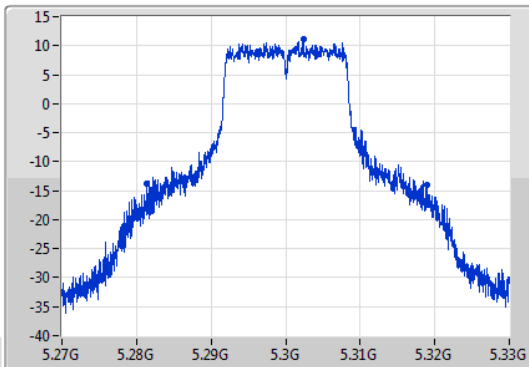

CF
5.3GHz
Span
60MHz
RBW
200kHz
VBW
1MHz
Sweep Time
100ms
Detector Type
Peak

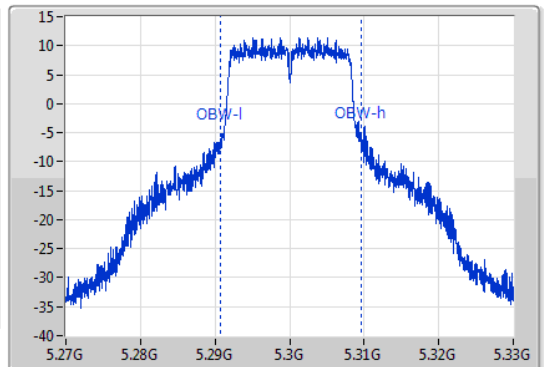

26dB(Hz)	Fl-26dB(Hz)	Fh-26dB(Hz)	OBW(Hz)	Fl-OBW(Hz)	Fh-OBW(Hz)	Limit(Hz)	Port
37.56M	5.28134G	5.3189G	18.801M	5.290795G	5.309595G	Inf	1

802.11a_Nss1,(6Mbps)_1TX

EBW

5320MHz

06/01/2020

CF: 5.32GHz
 Span: 60MHz
 RBW: 200kHz
 VBW: 1MHz
 Sweep Time: 100ms
 Detector Type: Peak

Port 1

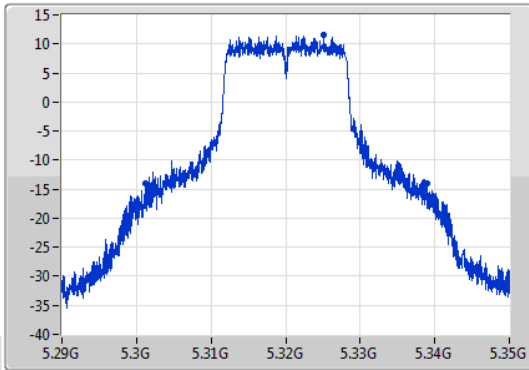

CF: 5.32GHz
 Span: 60MHz
 RBW: 200kHz
 VBW: 1MHz
 Sweep Time: 100ms
 Detector Type: Peak

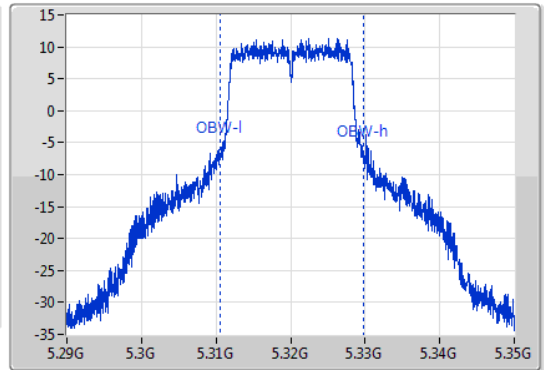

26dB(Hz)	Fl-26dB(Hz)	Fh-26dB(Hz)	OBW(Hz)	Fl-OBW(Hz)	Fh-OBW(Hz)	Limit(Hz)	Port
37.71M	5.30122G	5.33893G	19.19M	5.310585G	5.329775G	Inf	1

802.11a_Nss1,(6Mbps)_1TX

EBW

5500MHz

06/01/2020

CF: 5.5GHz
 Span: 60MHz
 RBW: 200kHz
 VBW: 1MHz
 Sweep Time: 100ms
 Detector Type: Peak

Port 1

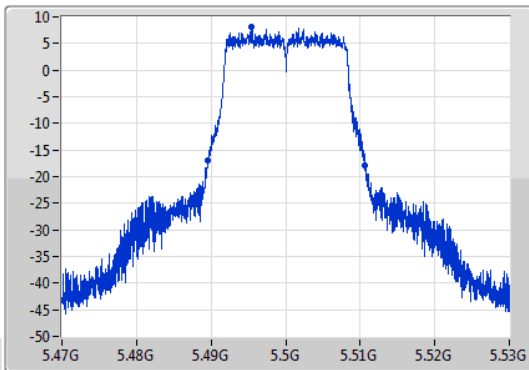

CF: 5.5GHz
 Span: 60MHz
 RBW: 200kHz
 VBW: 1MHz
 Sweep Time: 100ms
 Detector Type: Peak

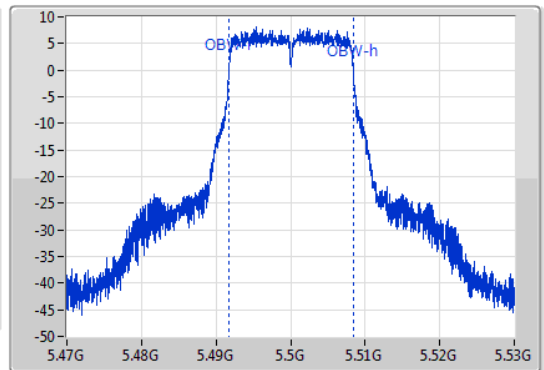

26dB(Hz)	Fl-26dB(Hz)	Fh-26dB(Hz)	OBW(Hz)	Fl-OBW(Hz)	Fh-OBW(Hz)	Limit(Hz)	Port
21.15M	5.48953G	5.51068G	16.762M	5.491724G	5.508486G	Inf	1

802.11a_Nss1,(6Mbps)_1TX

EBW

5580MHz

06/01/2020

CF
5.58GHz
Span
60MHz
RBW
200kHz
VBW
1MHz
Sweep Time
100ms
Detector Type
Peak
Port 1

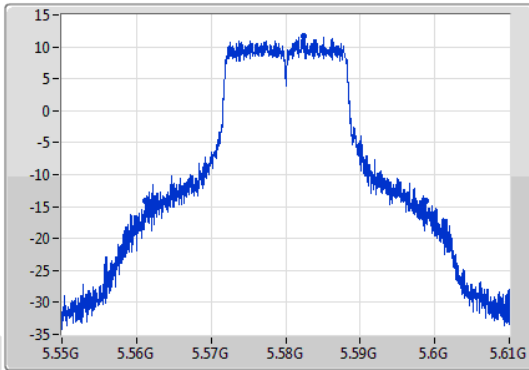

CF
5.58GHz
Span
60MHz
RBW
200kHz
VBW
1MHz
Sweep Time
100ms
Detector Type
Peak

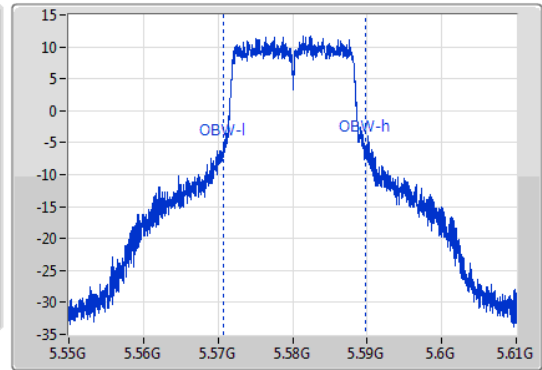

26dB(Hz)	Fl-26dB(Hz)	Fh-26dB(Hz)	OBW(Hz)	Fl-OBW(Hz)	Fh-OBW(Hz)	Limit(Hz)	Port
37.65M	5.56122G	5.59887G	19.13M	5.570705G	5.589835G	Inf	1

802.11a_Nss1,(6Mbps)_1TX

EBW

5700MHz

06/01/2020

CF
5.7GHz
Span
60MHz
RBW
200kHz
VBW
1MHz
Sweep Time
100ms
Detector Type
Peak
Port 1

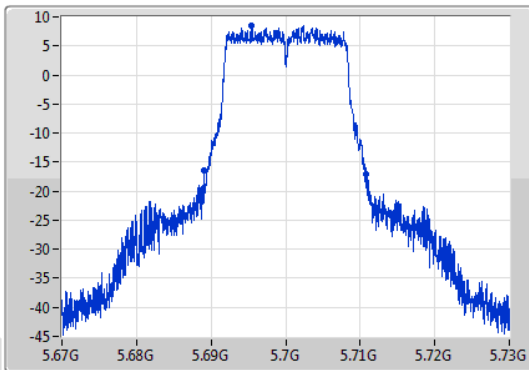

CF
5.7GHz
Span
60MHz
RBW
200kHz
VBW
1MHz
Sweep Time
100ms
Detector Type
Peak

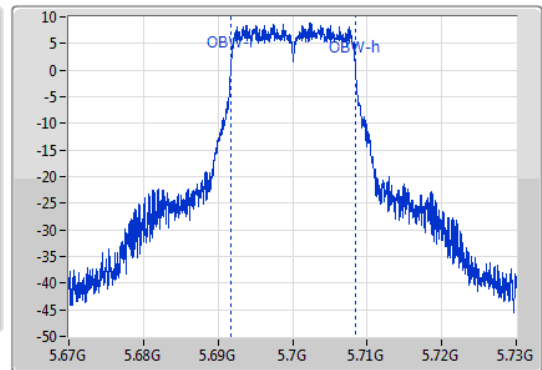

26dB(Hz)	Fl-26dB(Hz)	Fh-26dB(Hz)	OBW(Hz)	Fl-OBW(Hz)	Fh-OBW(Hz)	Limit(Hz)	Port
21.69M	5.68908G	5.71077G	16.762M	5.691724G	5.708486G	Inf	1

802.11a_Nss1,(6Mbps)_1TX

EBW

5720MHz Straddle 5.47-5.725GHz

06/01/2020

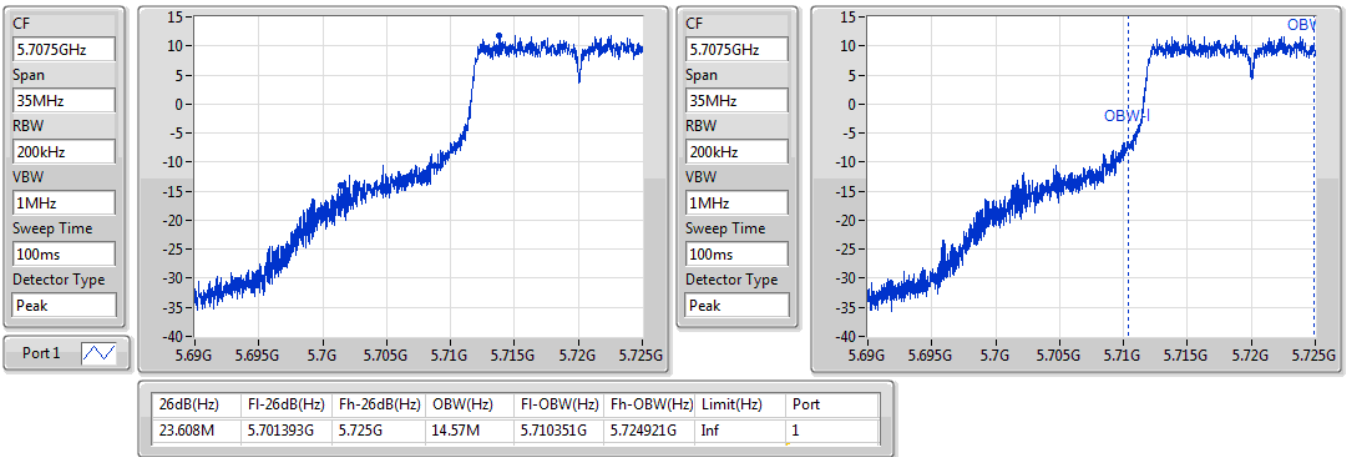

802.11a_Nss1,(6Mbps)_1TX

EBW

5720MHz Straddle 5.725-5.85GHz

06/01/2020

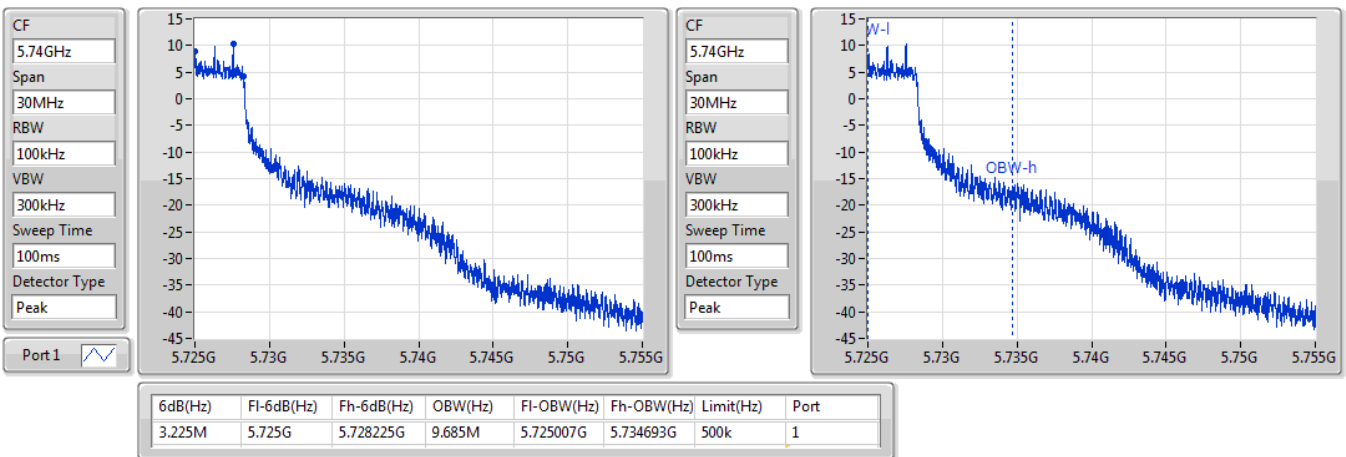

802.11ac VHT20_Nss1,(MCS0)_1TX

EBW

5260MHz

06/01/2020

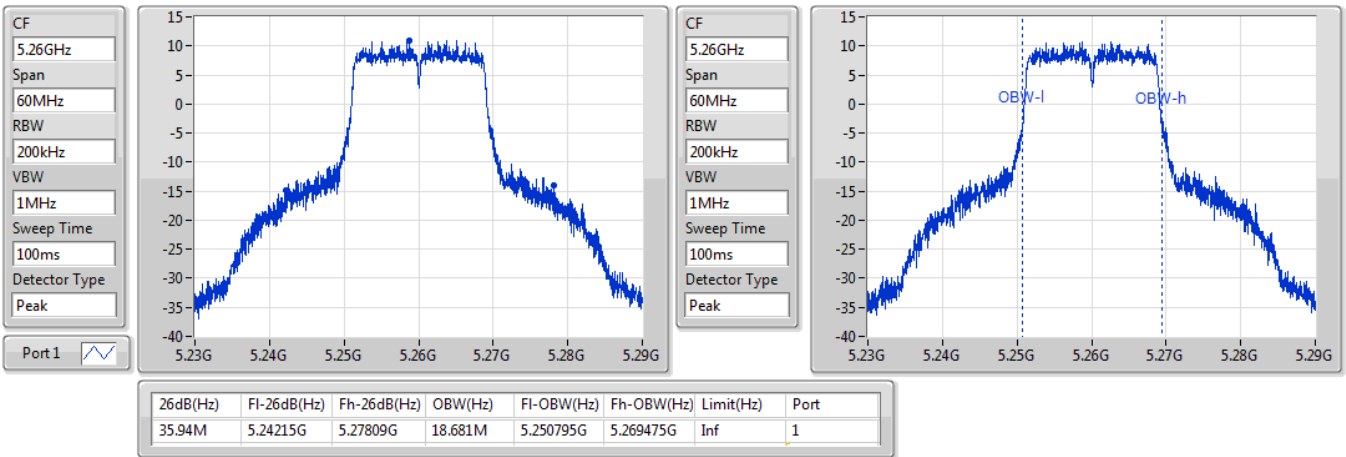

802.11ac VHT20_Nss1,(MCS0)_1TX

EBW

5300MHz

06/01/2020

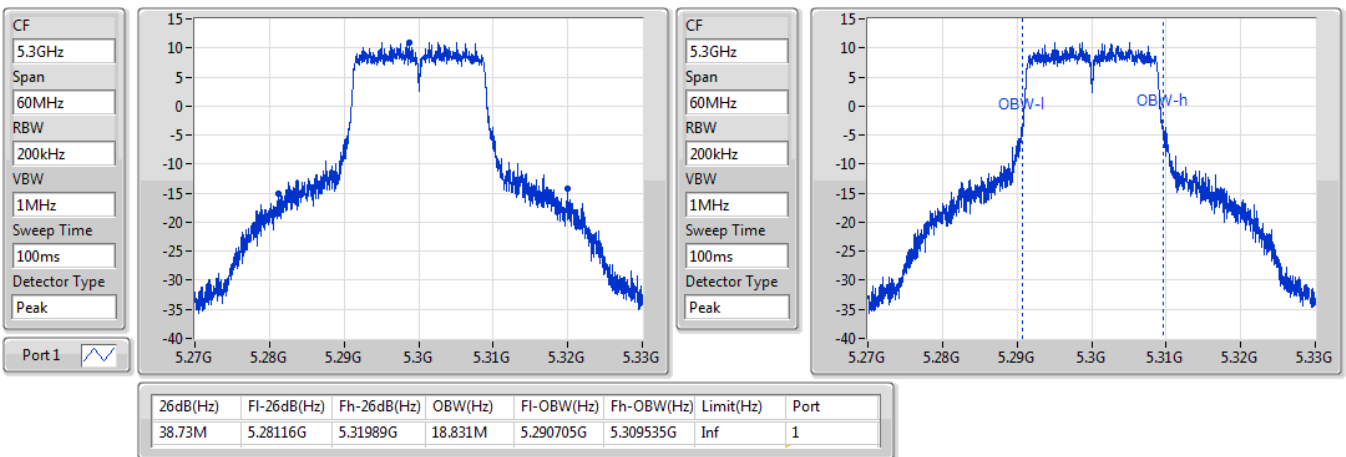

802.11ac VHT20_Nss1,(MCS0)_1TX

EBW

5320MHz

06/01/2020

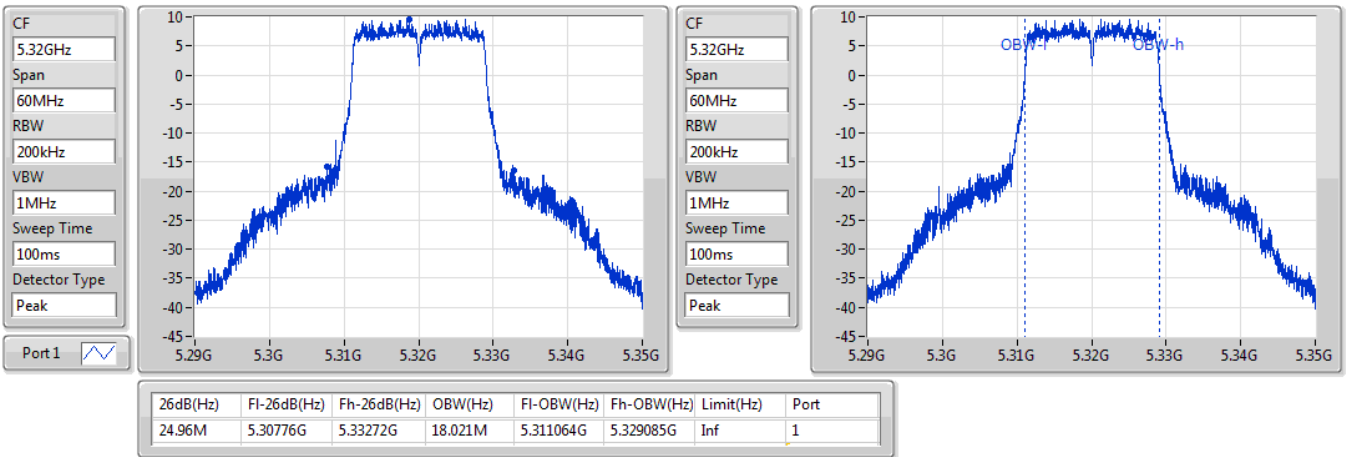

802.11ac VHT20_Nss1,(MCS0)_1TX

EBW

5500MHz

06/01/2020

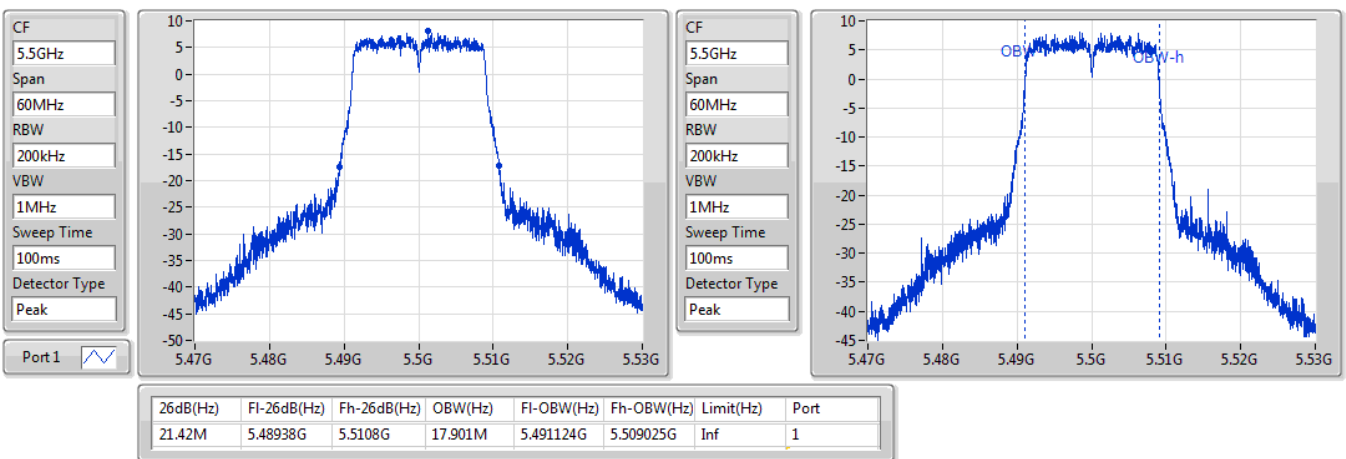

802.11ac VHT20_Nss1,(MCS0)_1TX

EBW

5580MHz

06/01/2020

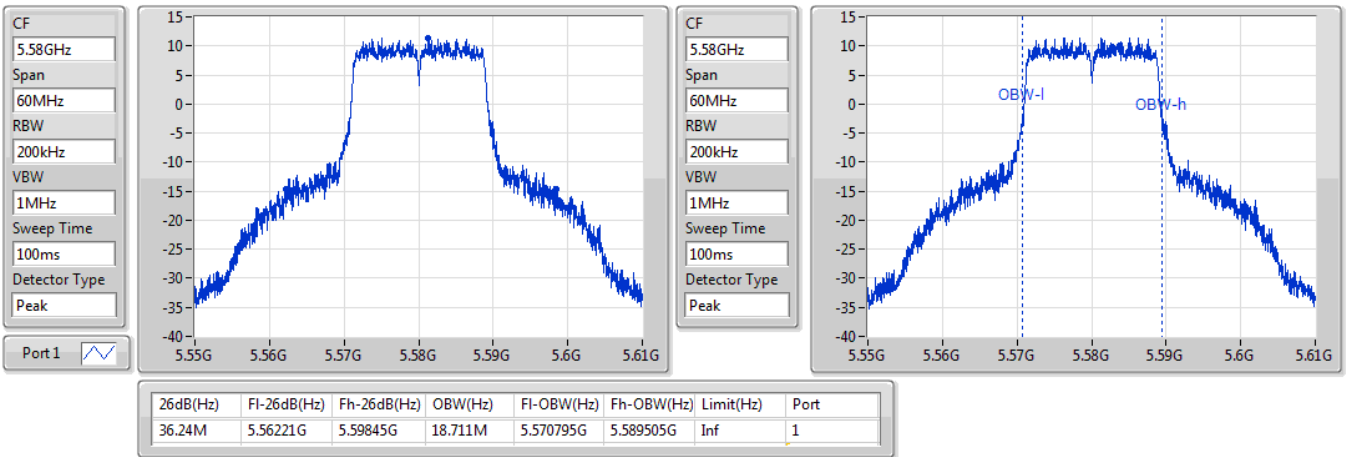

802.11ac VHT20_Nss1,(MCS0)_1TX

EBW

5700MHz

06/01/2020

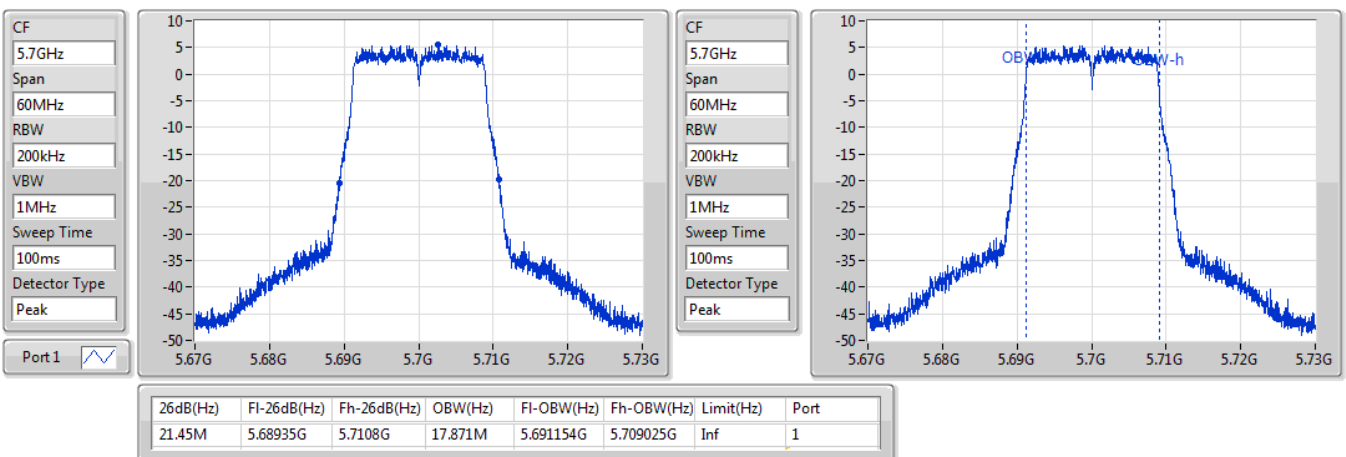

802.11ac VHT20_Nss1,(MCS0)_1TX
5720MHz Straddle 5.47-5.725GHz

EBW

06/01/2020

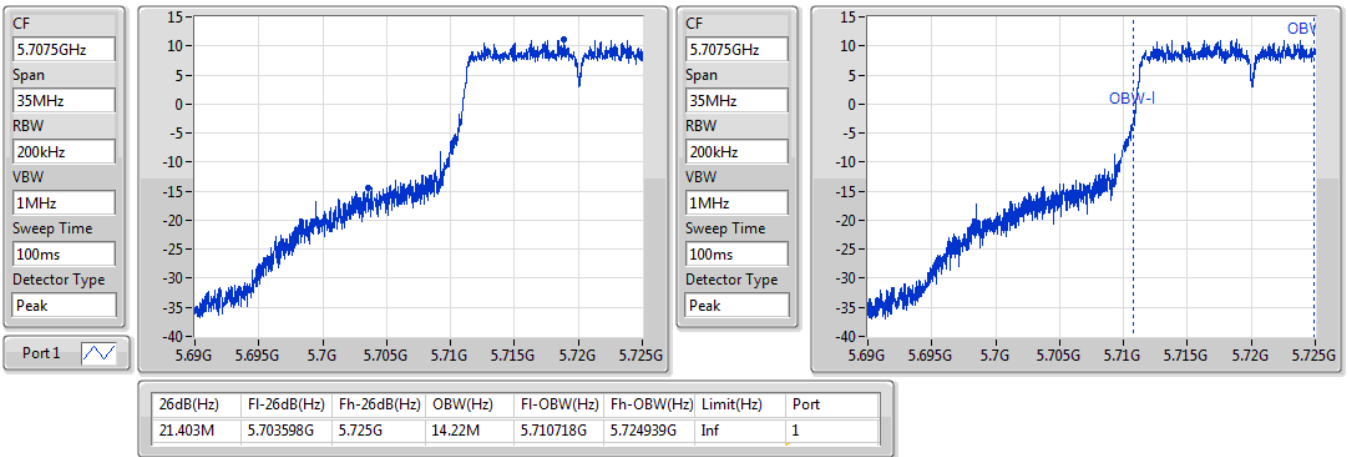

802.11ac VHT20_Nss1,(MCS0)_1TX
5720MHz Straddle 5.725-5.85GHz

EBW

06/01/2020

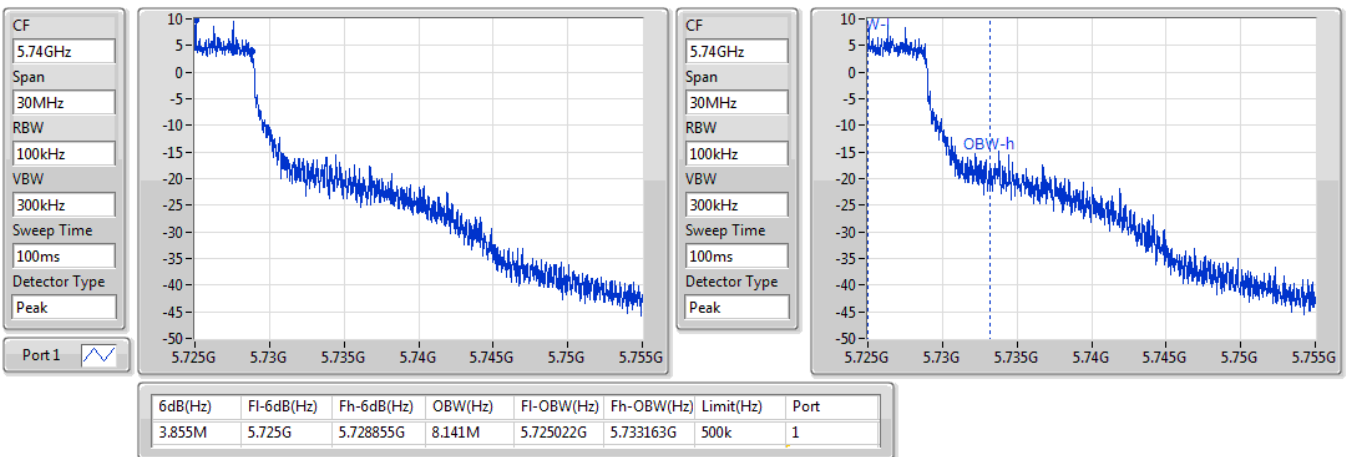

802.11ac VHT40_Nss1,(MCS0)_1TX

EBW

5270MHz

06/01/2020

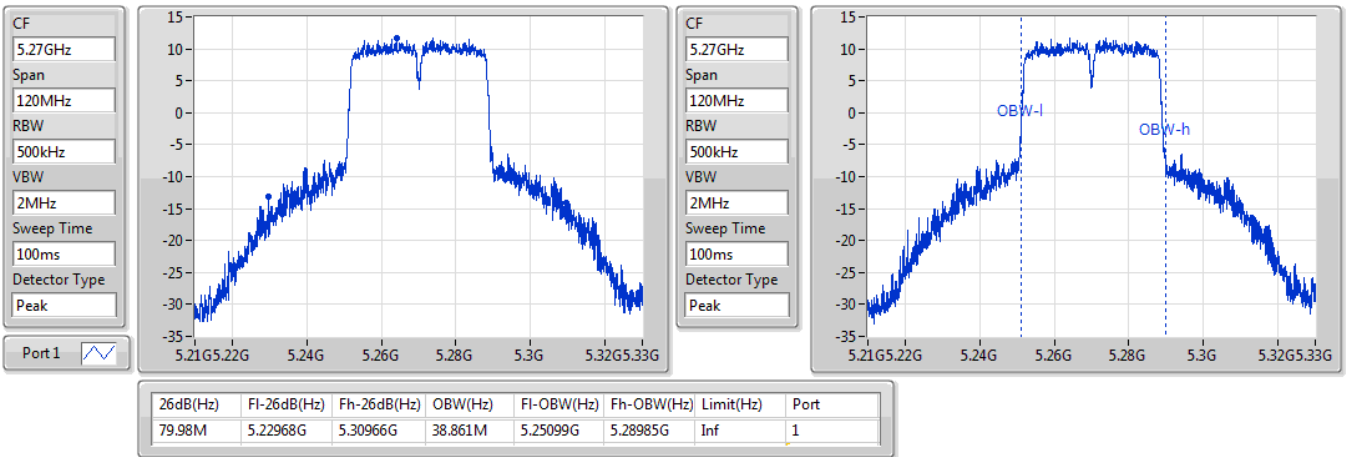

802.11ac VHT40_Nss1,(MCS0)_1TX

EBW

5310MHz

06/01/2020

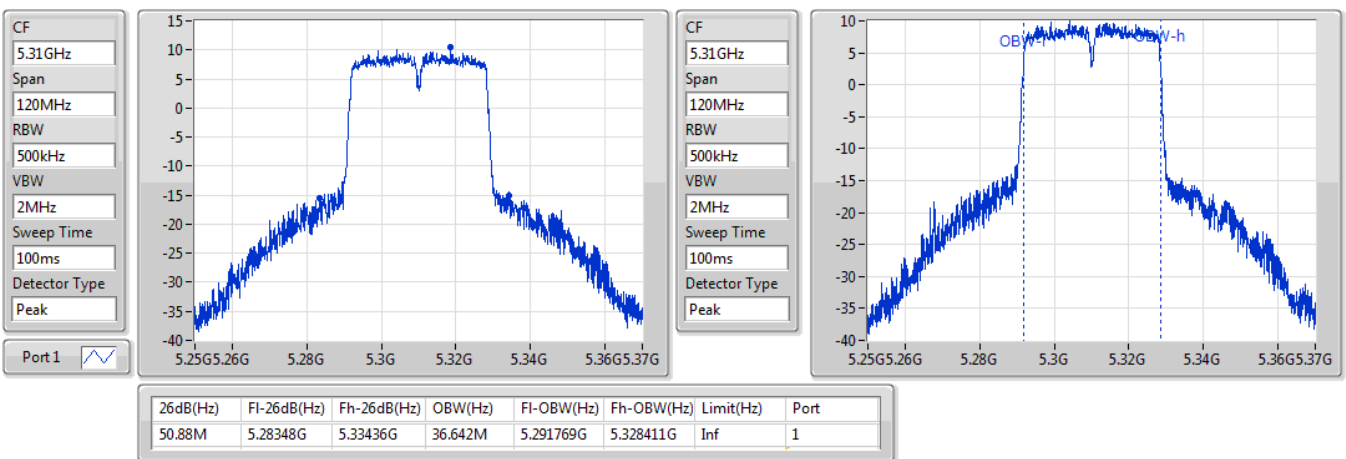

802.11ac VHT40_Nss1,(MCS0)_1TX

EBW

5510MHz

06/01/2020

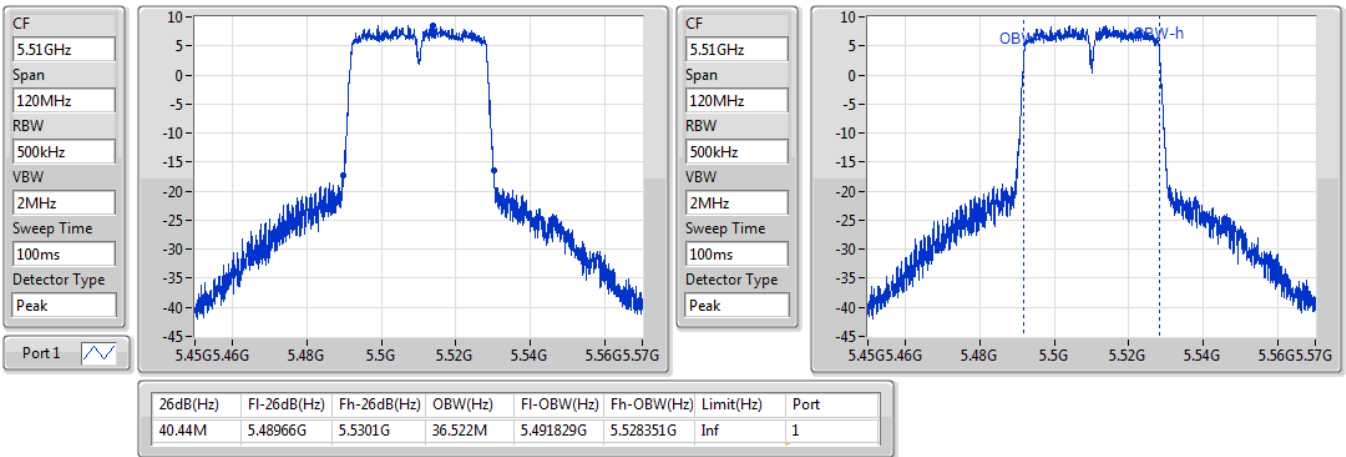

802.11ac VHT40_Nss1,(MCS0)_1TX

EBW

5550MHz

06/01/2020

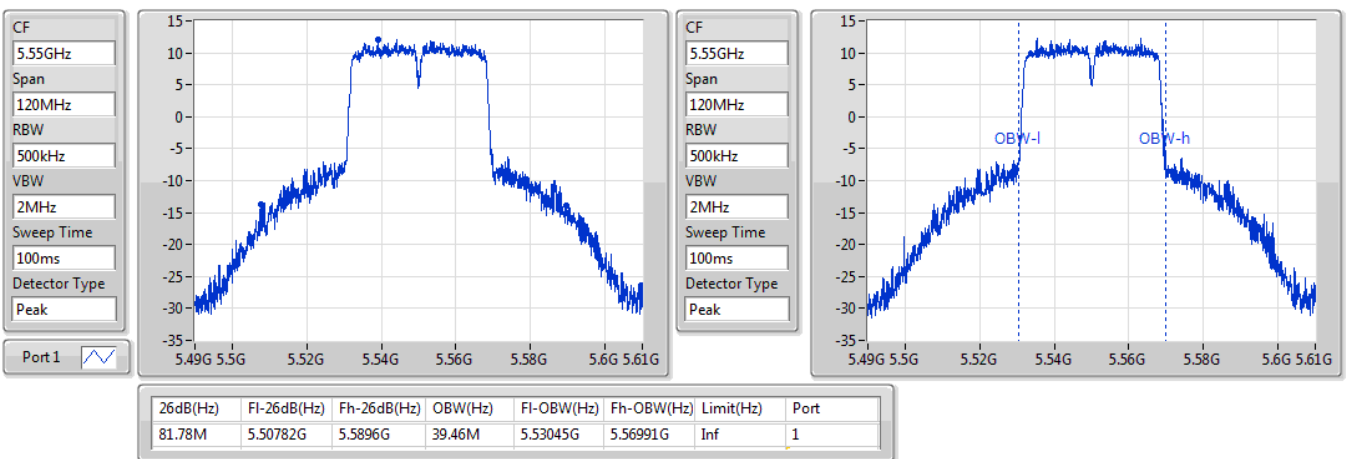

802.11ac VHT40_Nss1,(MCS0)_1TX

EBW

5670MHz

06/01/2020

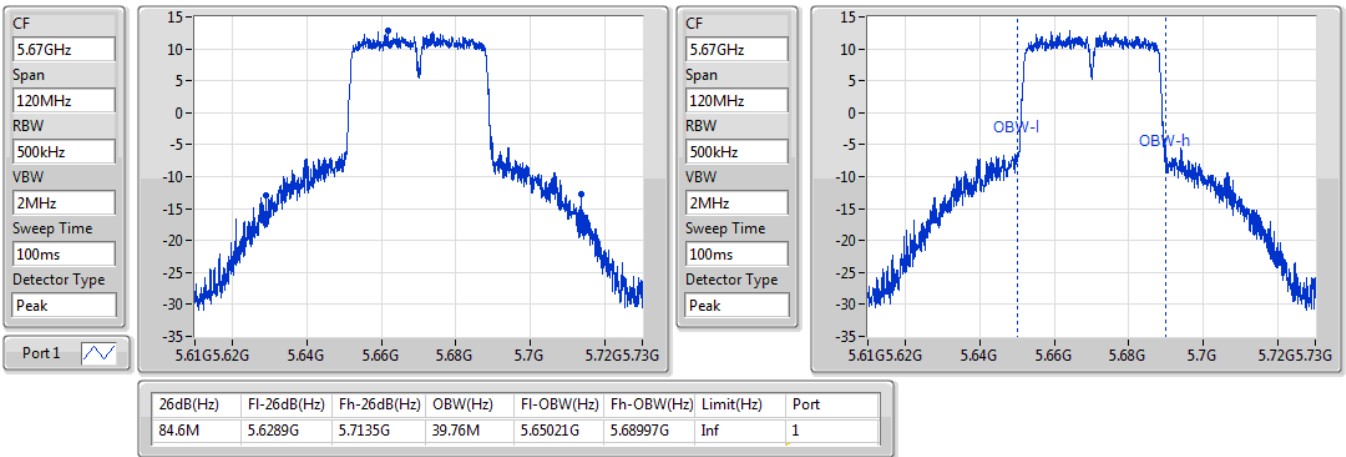

802.11ac VHT40_Nss1,(MCS0)_1TX

EBW

5710MHz Straddle 5.47-5.725GHz

06/01/2020

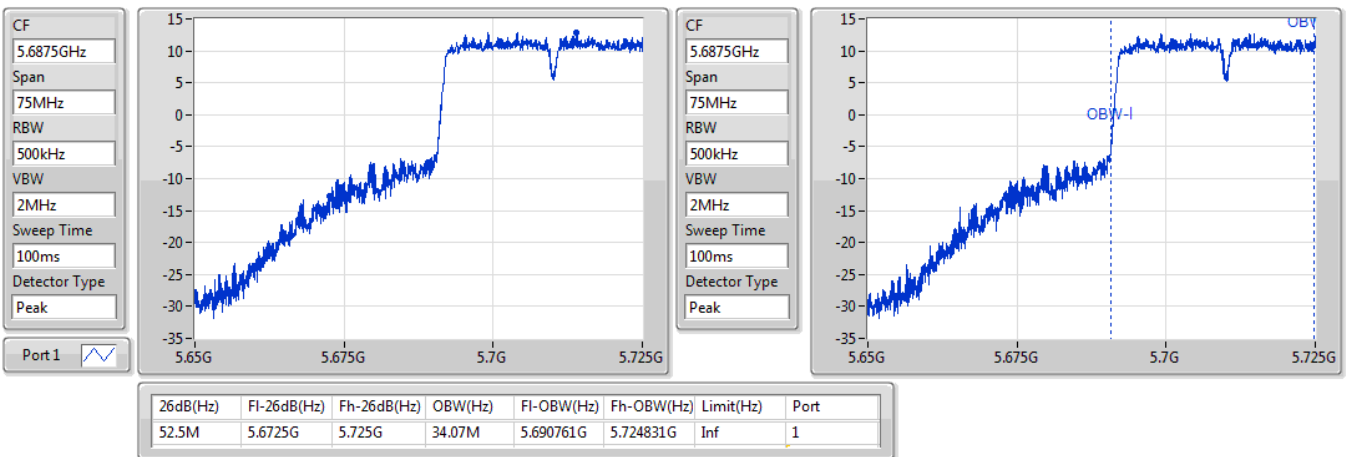

802.11ac VHT40_Nss1,(MCS0)_1TX
5710MHz Straddle 5.725-5.85GHz

EBW

06/01/2020

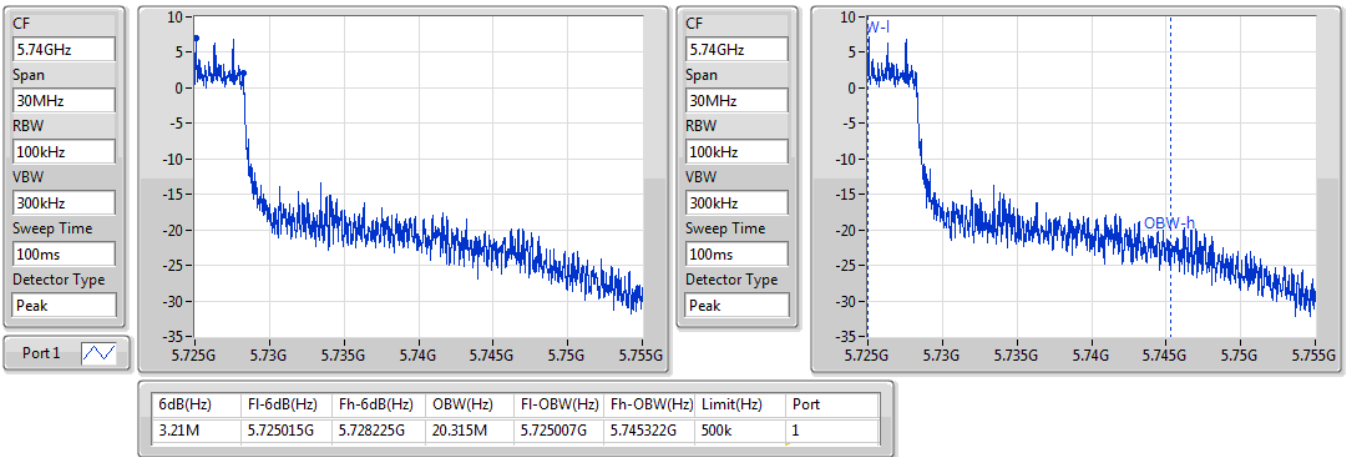

802.11ac VHT80_Nss1,(MCS0)_1TX
5290MHz

EBW

06/01/2020

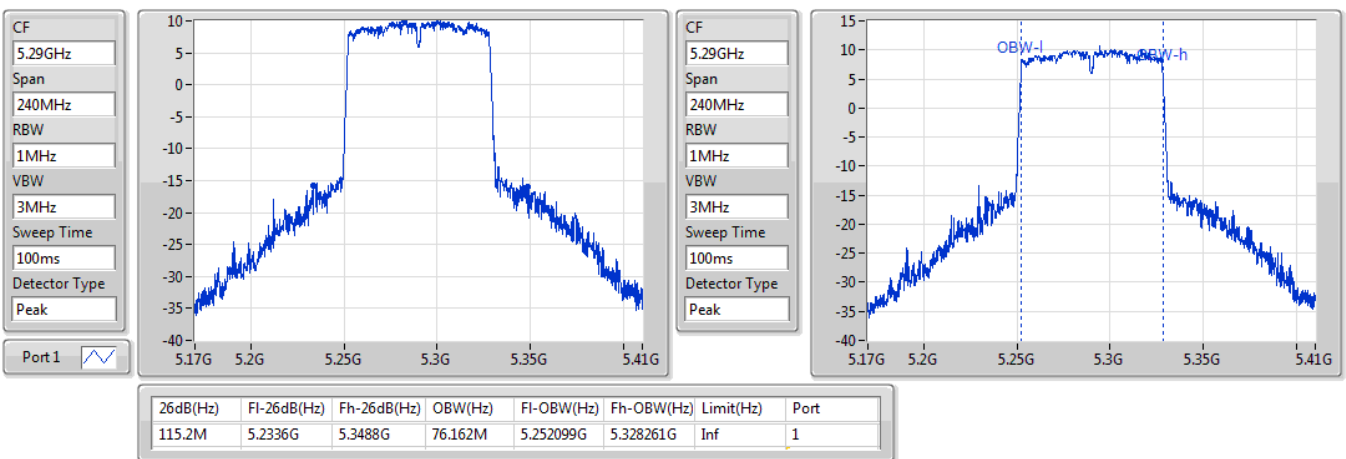

802.11ac VHT80_Nss1,(MCS0)_1TX

EBW

5530MHz

06/01/2020

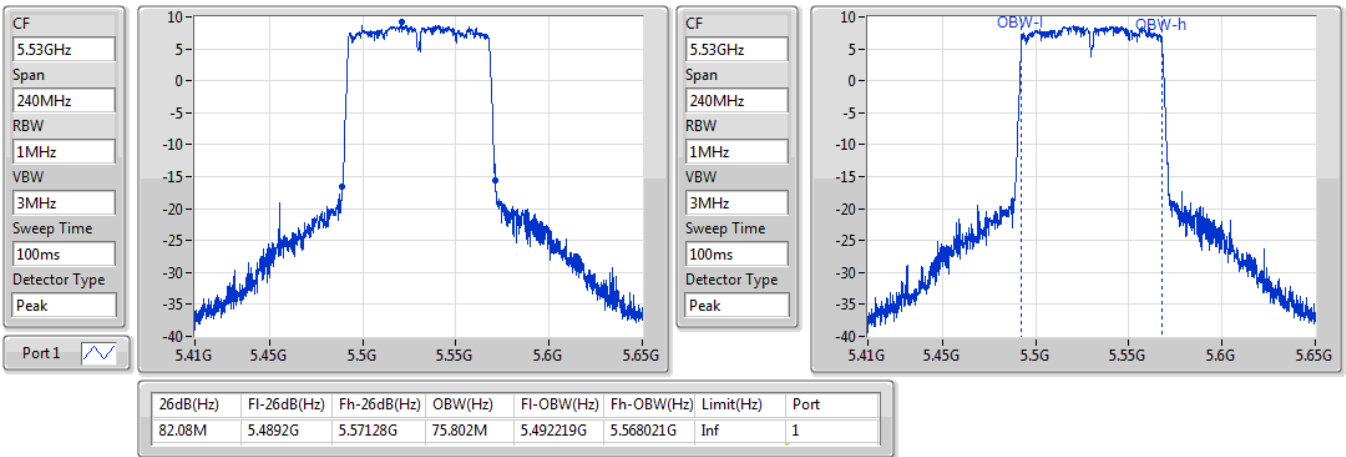

802.11ac VHT80_Nss1,(MCS0)_1TX

EBW

5610MHz

06/01/2020

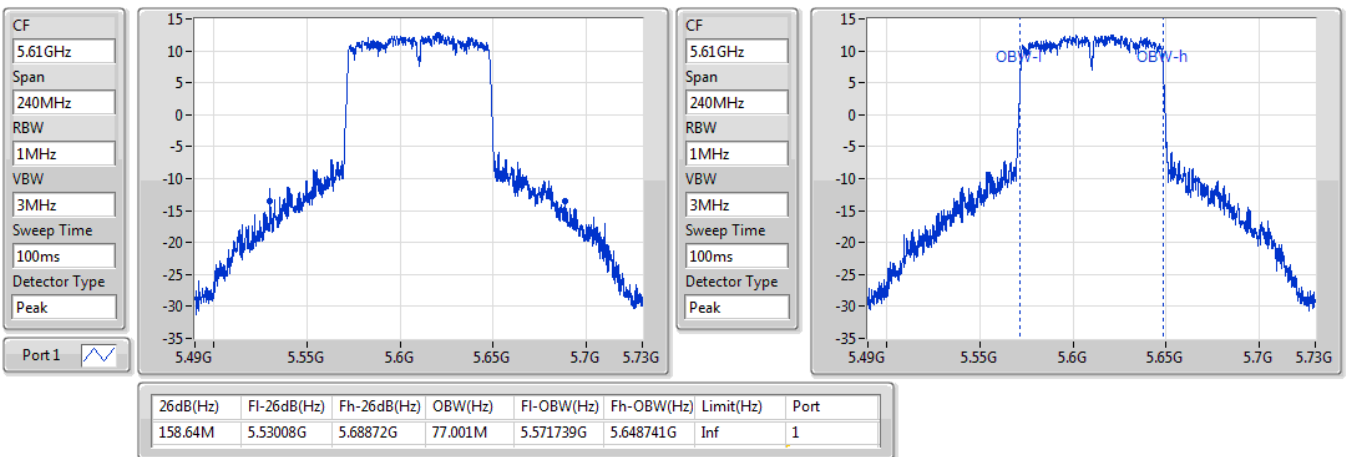

802.11ac VHT80_Nss1,(MCS0)_1TX

EBW

5690MHz Straddle 5.47-5.725GHz

06/01/2020

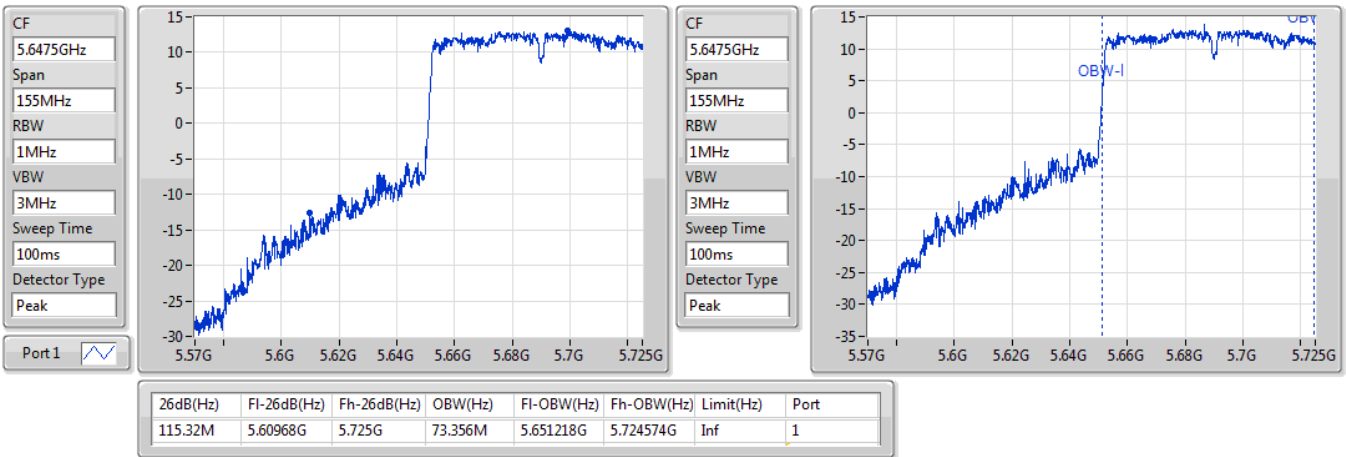

802.11ac VHT80_Nss1,(MCS0)_1TX

EBW

5690MHz Straddle 5.725-5.85GHz

06/01/2020

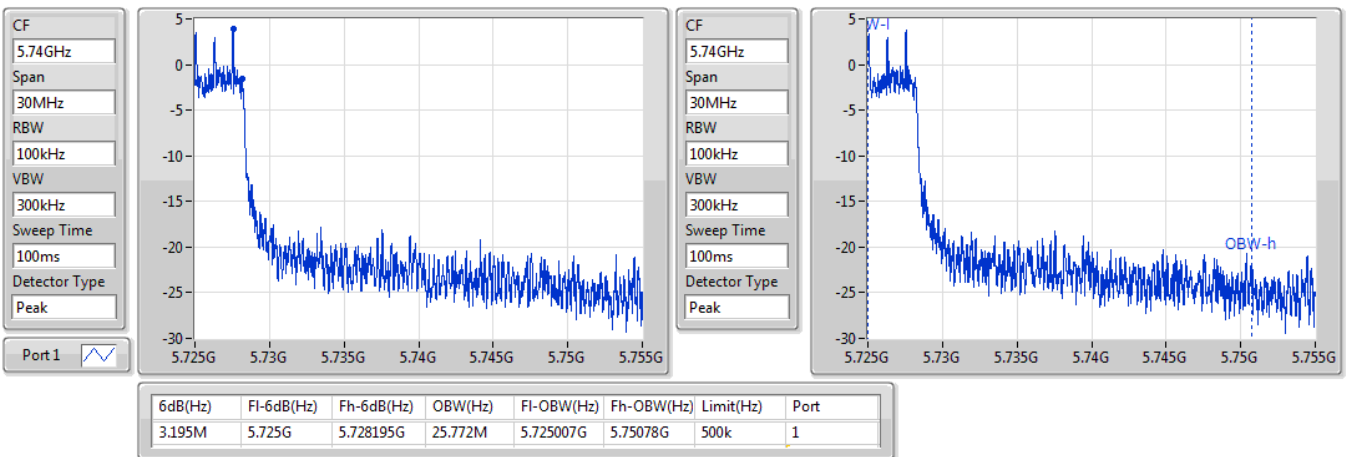

802.11ax HEW20_Nss1,(MCS0)_1TX

EBW

5260MHz

06/01/2020

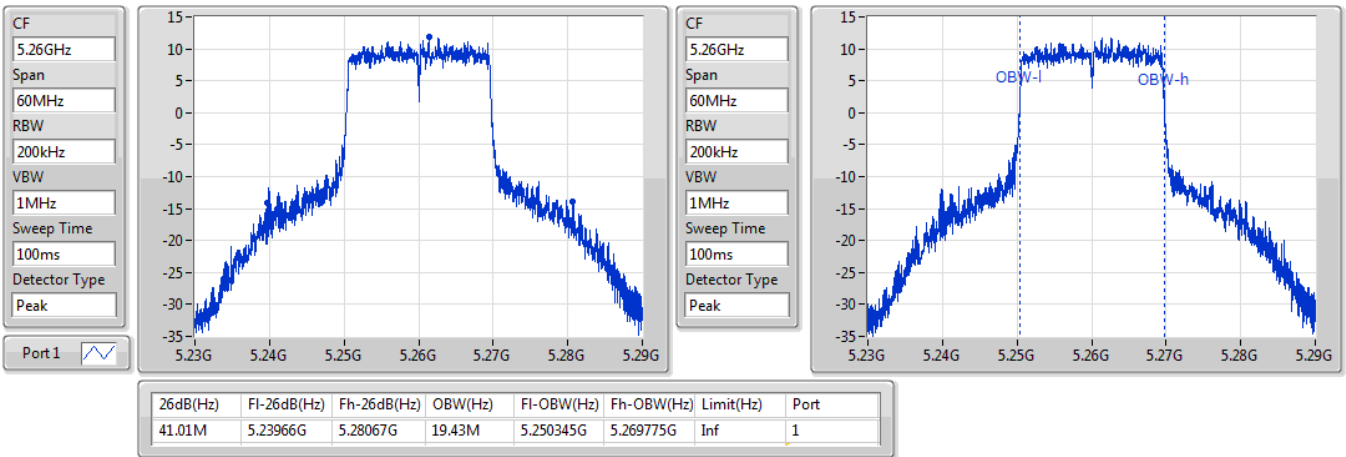

802.11ax HEW20_Nss1,(MCS0)_1TX

EBW

5300MHz

06/01/2020

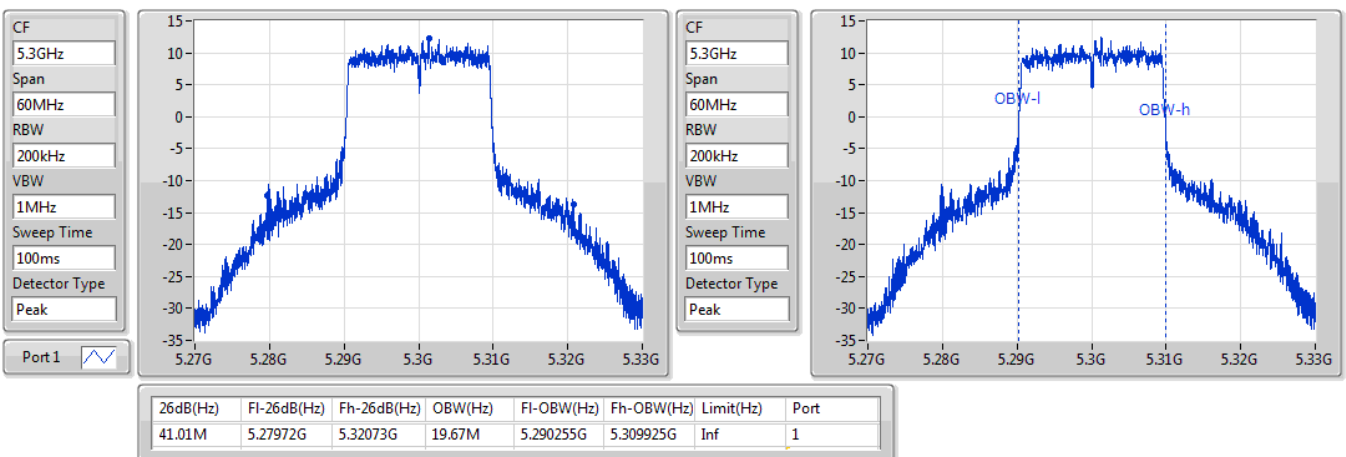

802.11ax HEW20_Nss1,(MCS0)_1TX

EBW

5320MHz

06/01/2020

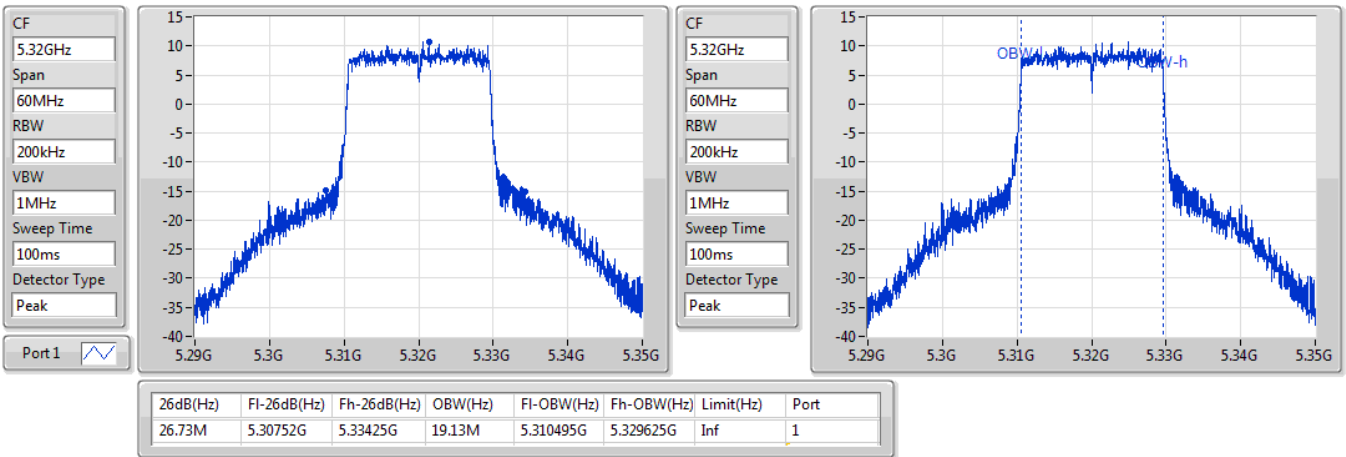

802.11ax HEW20_Nss1,(MCS0)_1TX

EBW

5500MHz

06/01/2020

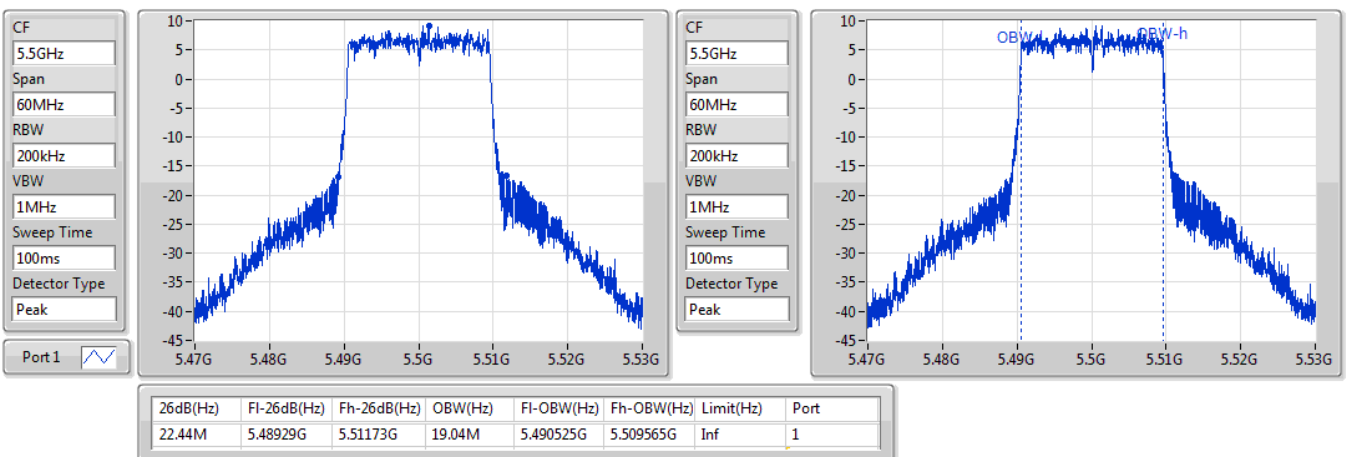

802.11ax HEW20_Nss1,(MCS0)_1TX

EBW

5580MHz

06/01/2020

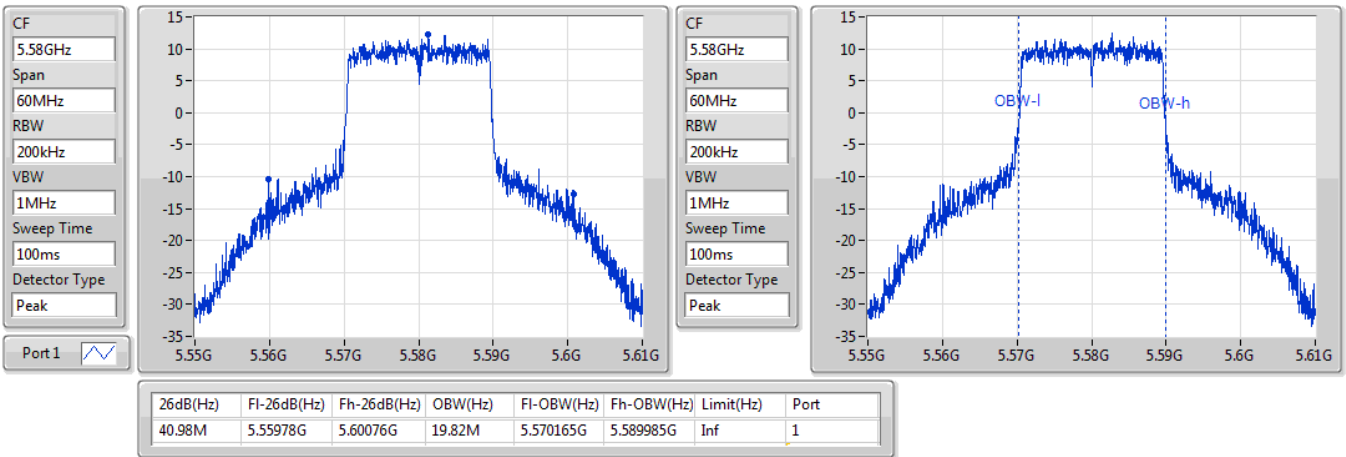

802.11ax HEW20_Nss1,(MCS0)_1TX

EBW

5700MHz

06/01/2020



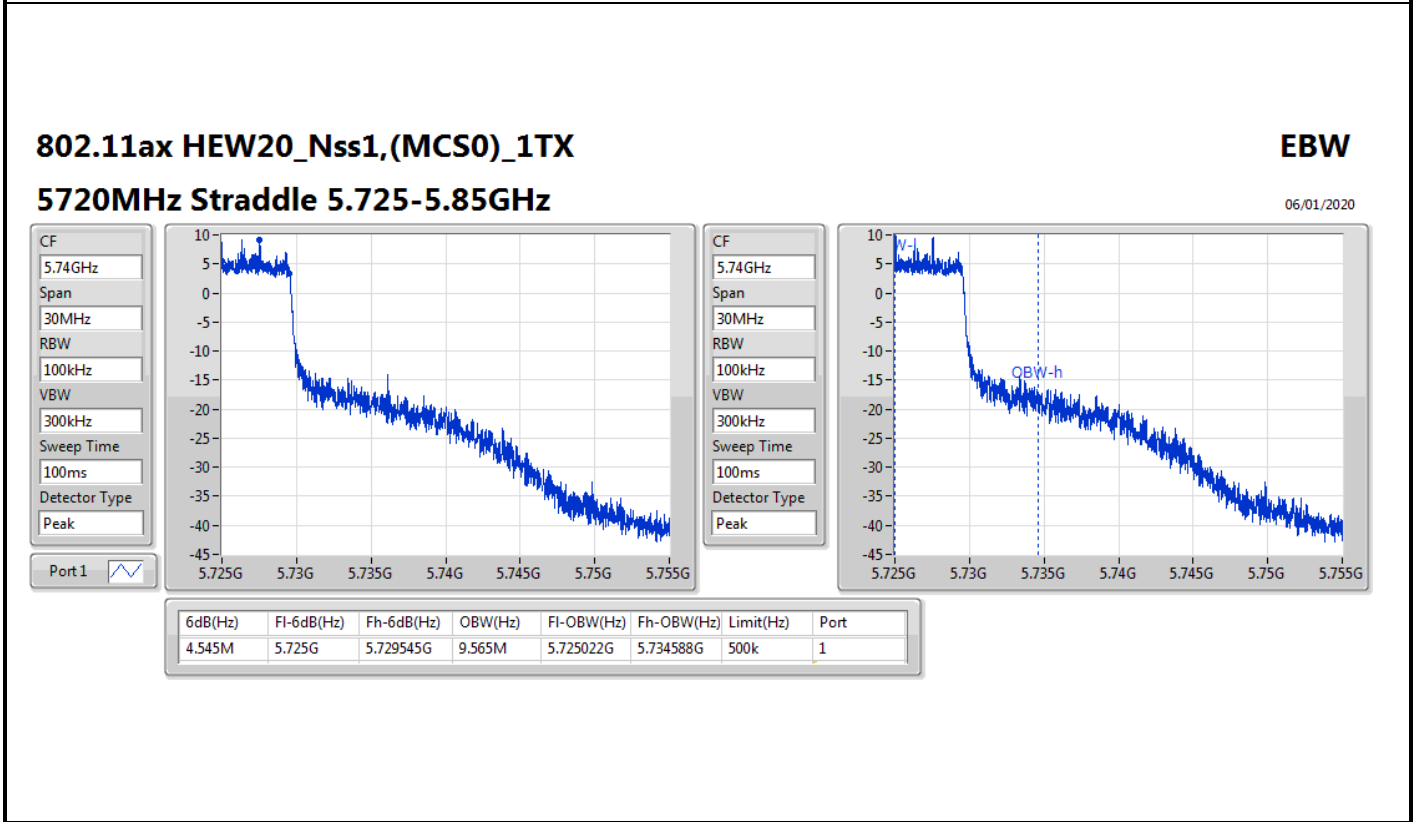
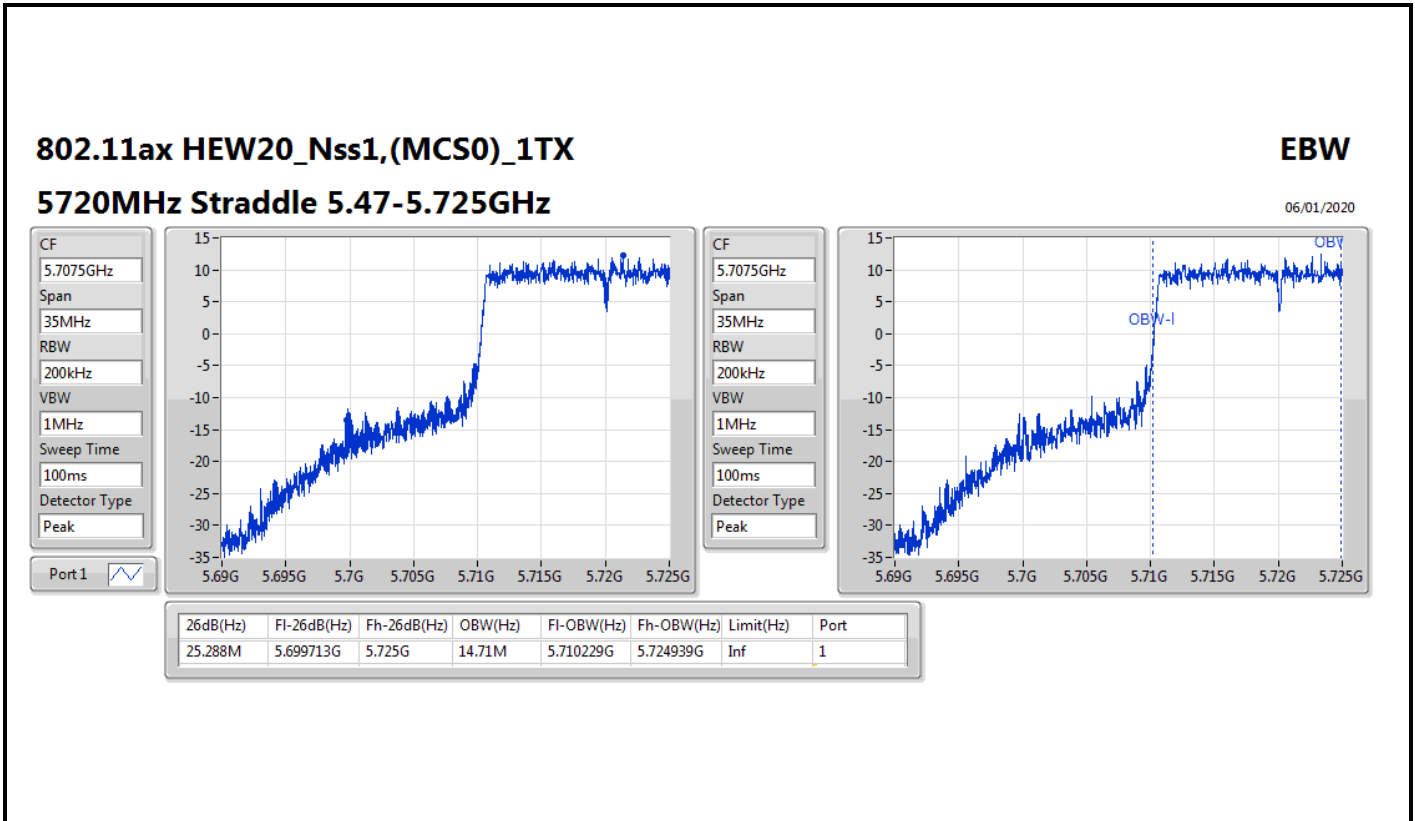

802.11ax HEW40_Nss1,(MCS0)_1TX

EBW

5270MHz

06/01/2020

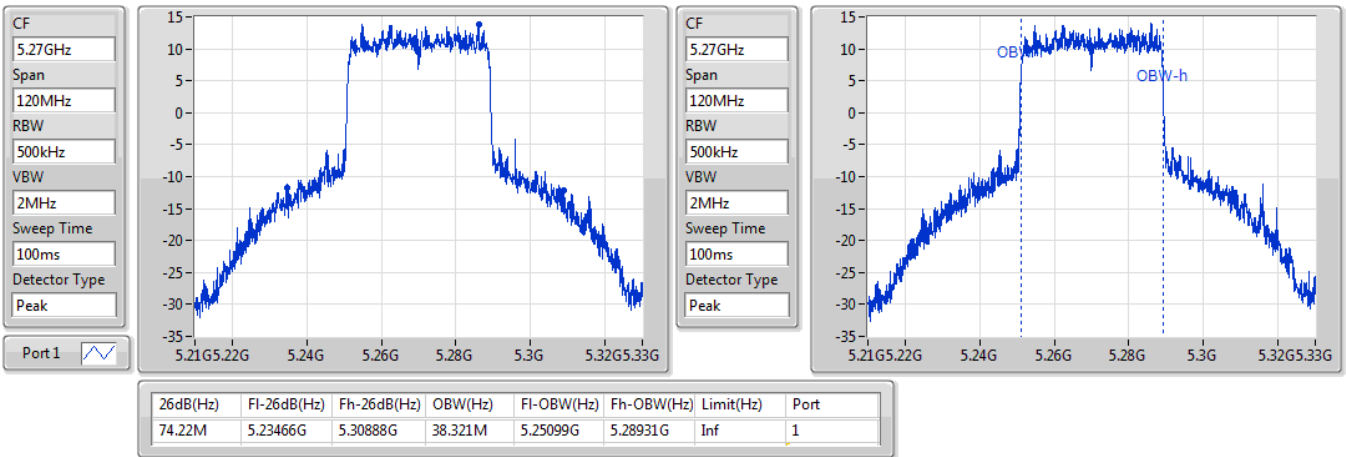

802.11ax HEW40_Nss1,(MCS0)_1TX

EBW

5310MHz

06/01/2020

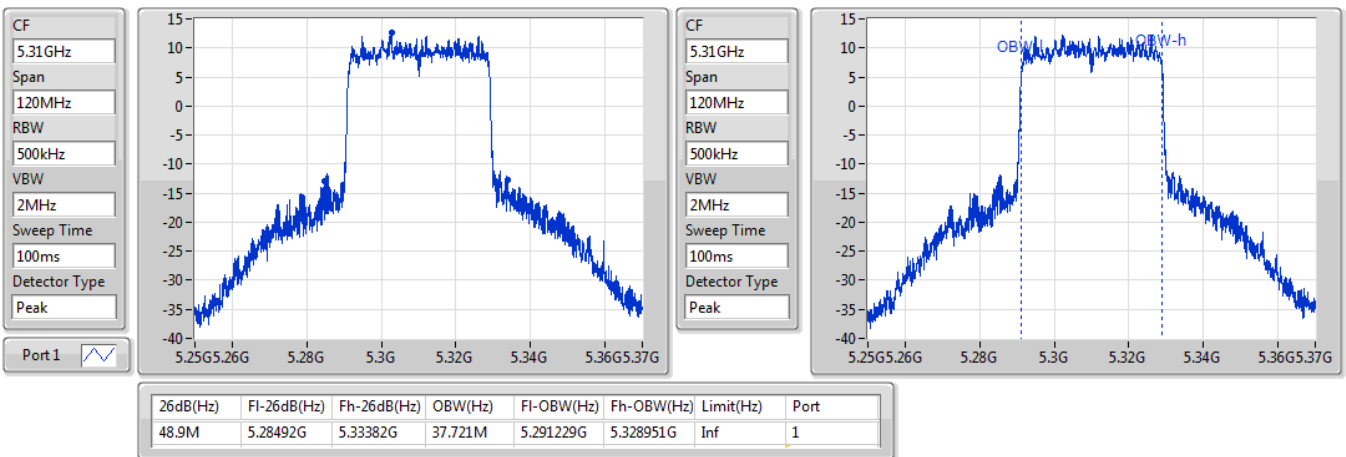

802.11ax HEW40_Nss1,(MCS0)_1TX

EBW

5510MHz

06/01/2020

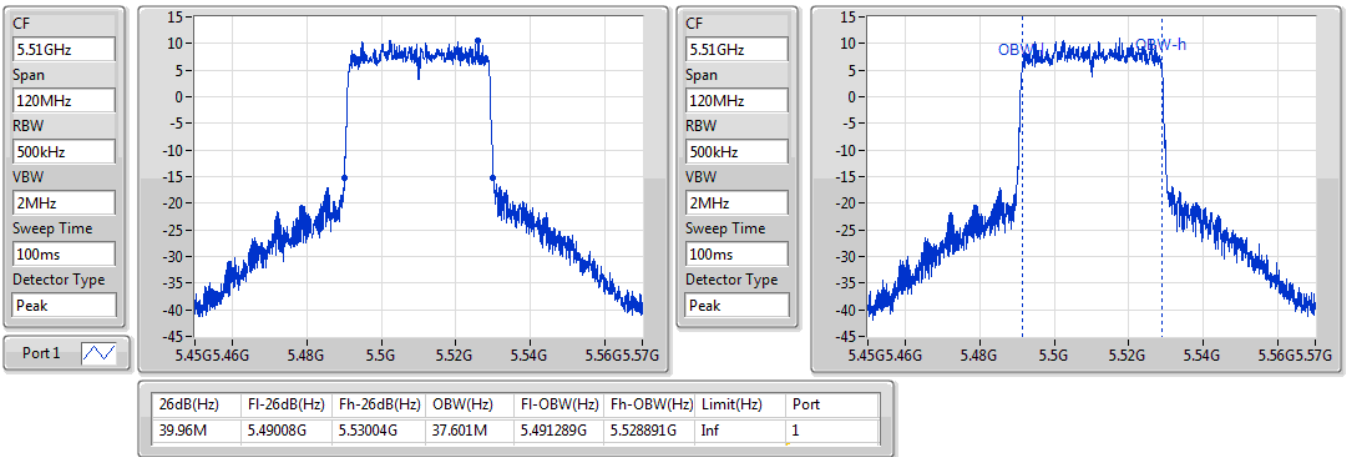

802.11ax HEW40_Nss1,(MCS0)_1TX

EBW

5550MHz

06/01/2020

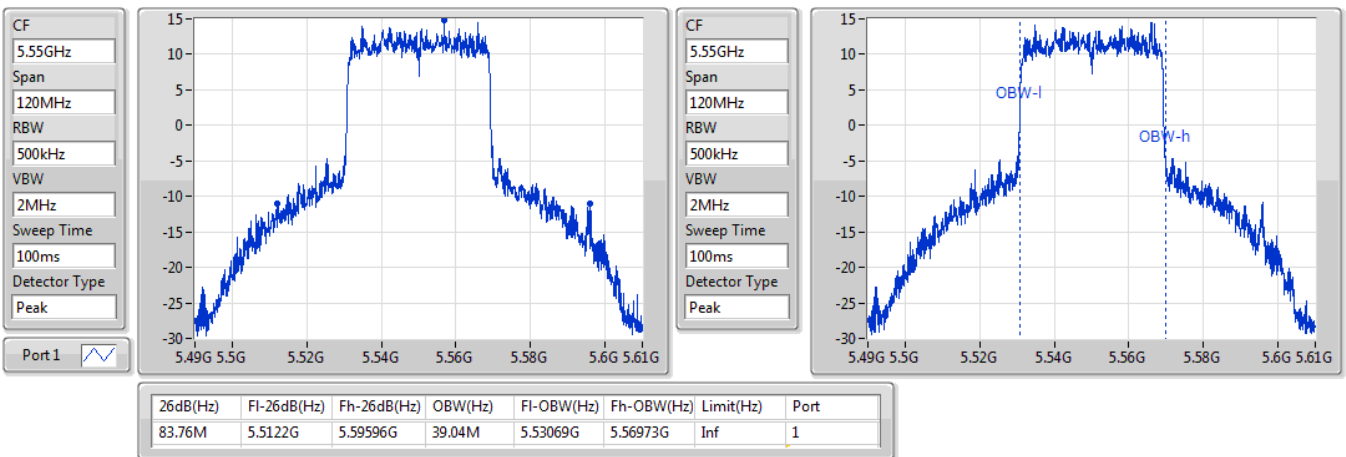

802.11ax HEW40_Nss1,(MCS0)_1TX

EBW

5670MHz

06/01/2020

CF
5.67GHz
Span
120MHz
RBW
500kHz
VBW
2MHz
Sweep Time
100ms
Detector Type
Peak
Port 1

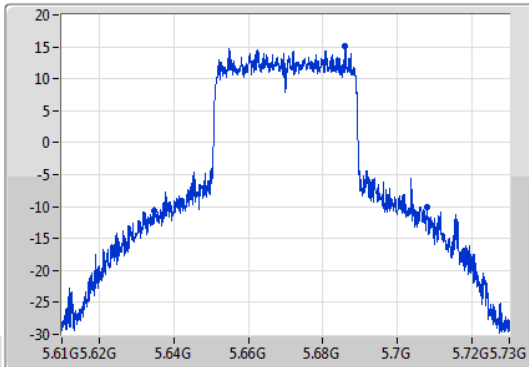

CF
5.67GHz
Span
120MHz
RBW
500kHz
VBW
2MHz
Sweep Time
100ms
Detector Type
Peak

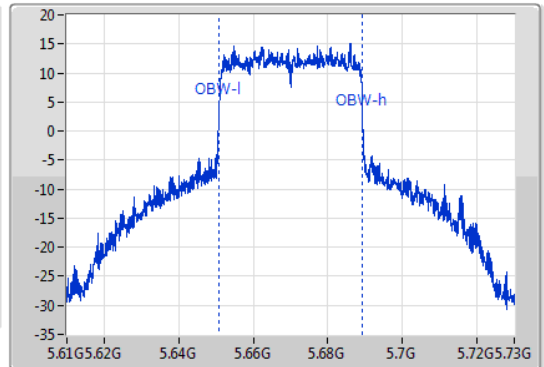

26dB(Hz)	Fl-26dB(Hz)	Fh-26dB(Hz)	OBW(Hz)	Fl-OBW(Hz)	Fh-OBW(Hz)	Limit(Hz)	Port
73.32M	5.6346G	5.70792G	38.561M	5.65081G	5.68937G	Inf	1

802.11ax HEW40_Nss1,(MCS0)_1TX

EBW

5710MHz Straddle 5.47-5.725GHz

06/01/2020

CF
5.6875GHz
Span
75MHz
RBW
500kHz
VBW
2MHz
Sweep Time
100ms
Detector Type
Peak
Port 1

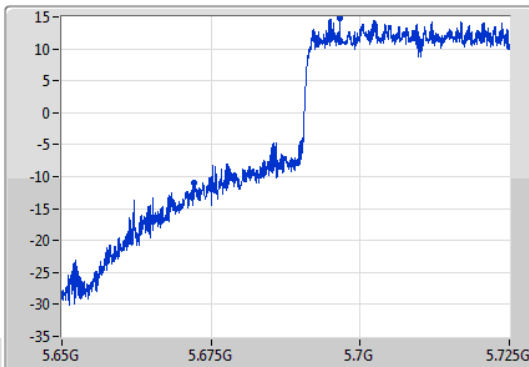

CF
5.6875GHz
Span
75MHz
RBW
500kHz
VBW
2MHz
Sweep Time
100ms
Detector Type
Peak

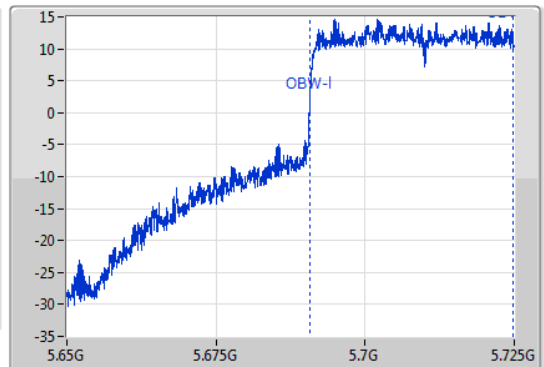

26dB(Hz)	Fl-26dB(Hz)	Fh-26dB(Hz)	OBW(Hz)	Fl-OBW(Hz)	Fh-OBW(Hz)	Limit(Hz)	Port
52.8M	5.6722G	5.725G	34.07M	5.690723G	5.724794G	Inf	1

802.11ax HEW40_Nss1,(MCS0)_1TX

EBW

5710MHz Straddle 5.725-5.85GHz

06/01/2020

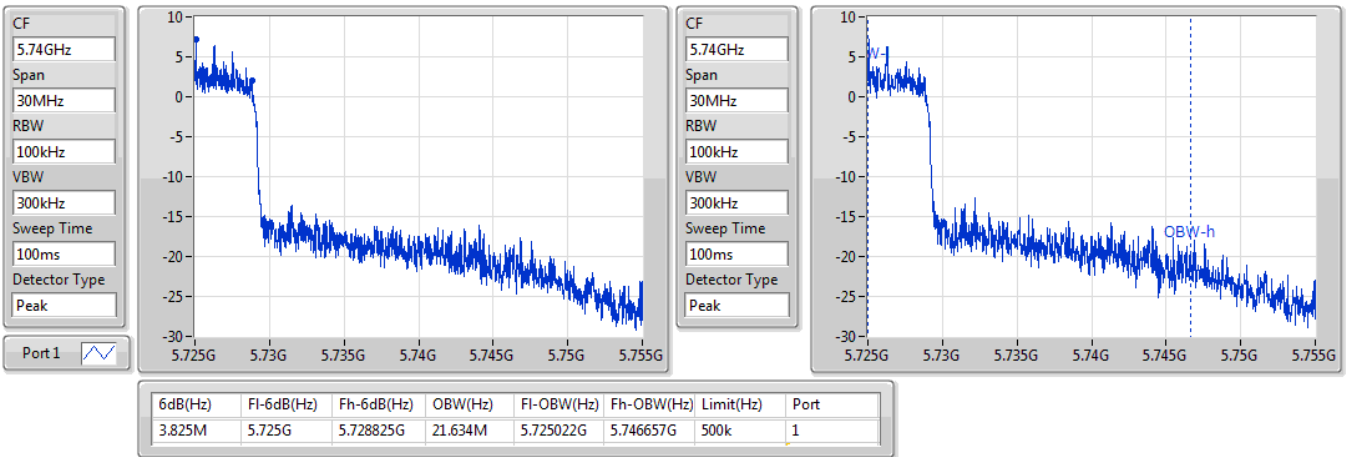

802.11ax HEW80_Nss1,(MCS0)_1TX

EBW

5290MHz

06/01/2020

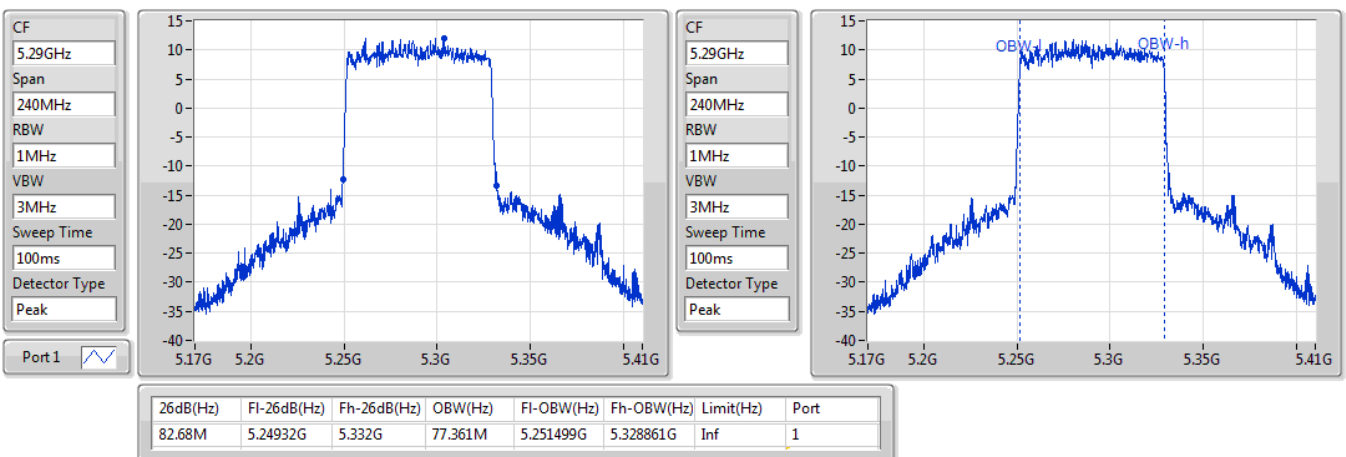

802.11ax HEW80_Nss1,(MCS0)_1TX

EBW

5530MHz

06/01/2020

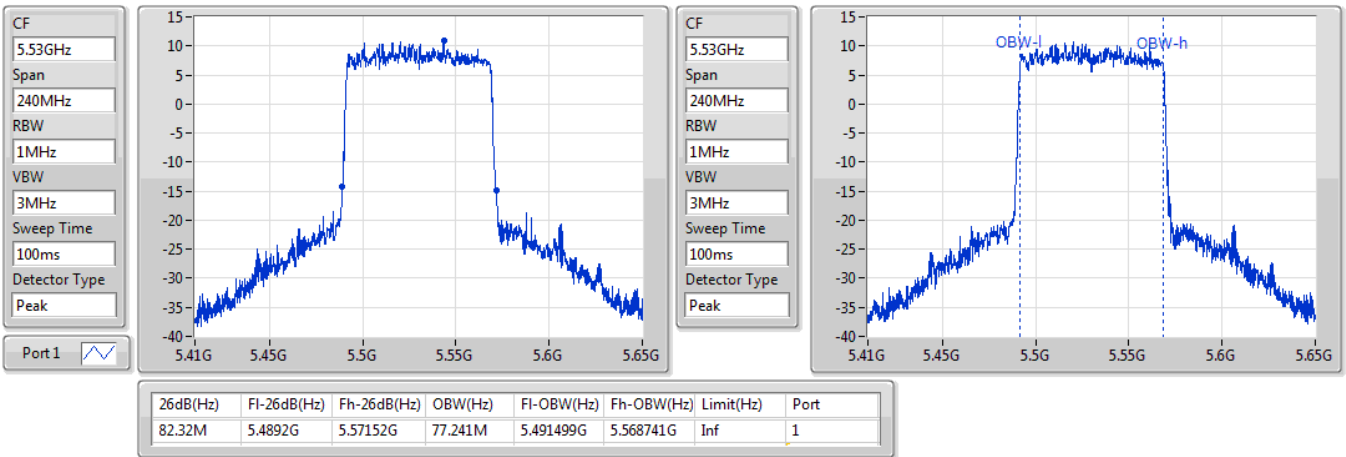

802.11ax HEW80_Nss1,(MCS0)_1TX

EBW

5610MHz

06/01/2020

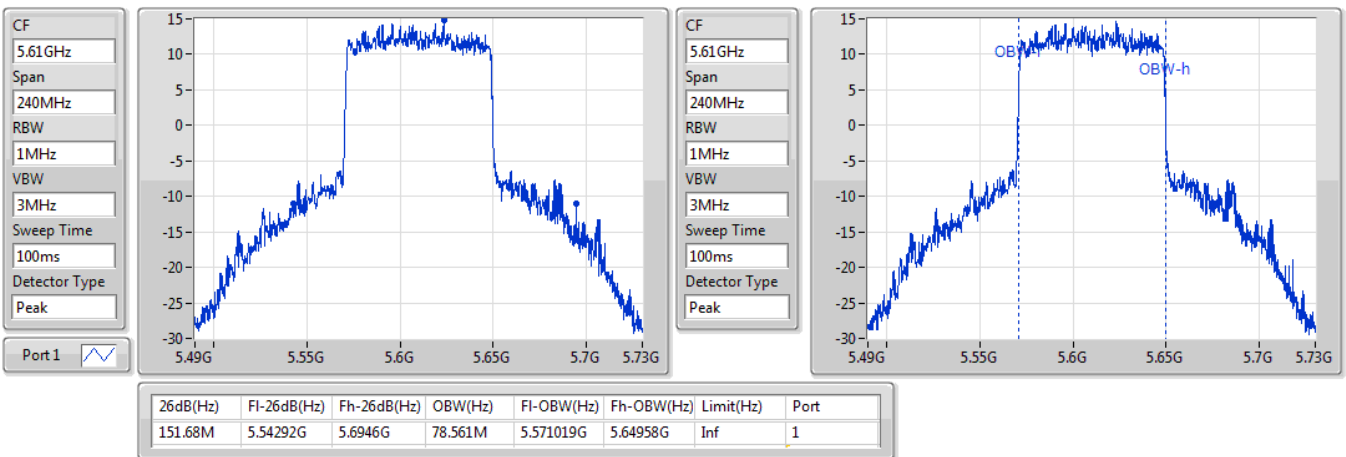

802.11ax HEW80_Nss1,(MCS0)_1TX

EBW

5690MHz Straddle 5.47-5.725GHz

06/01/2020

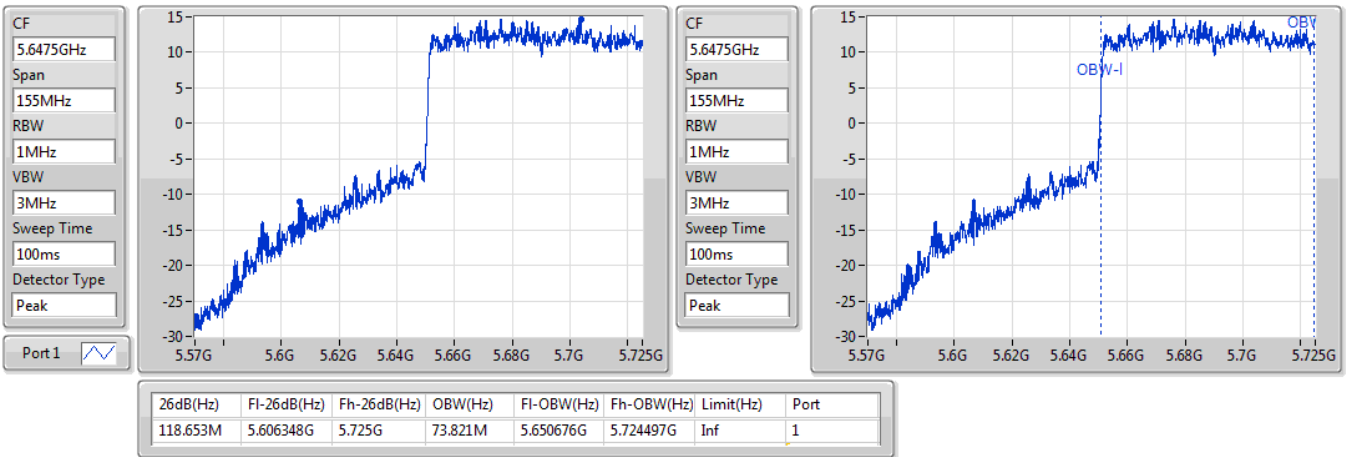

802.11ax HEW80_Nss1,(MCS0)_1TX

EBW

5690MHz Straddle 5.725-5.85GHz

06/01/2020

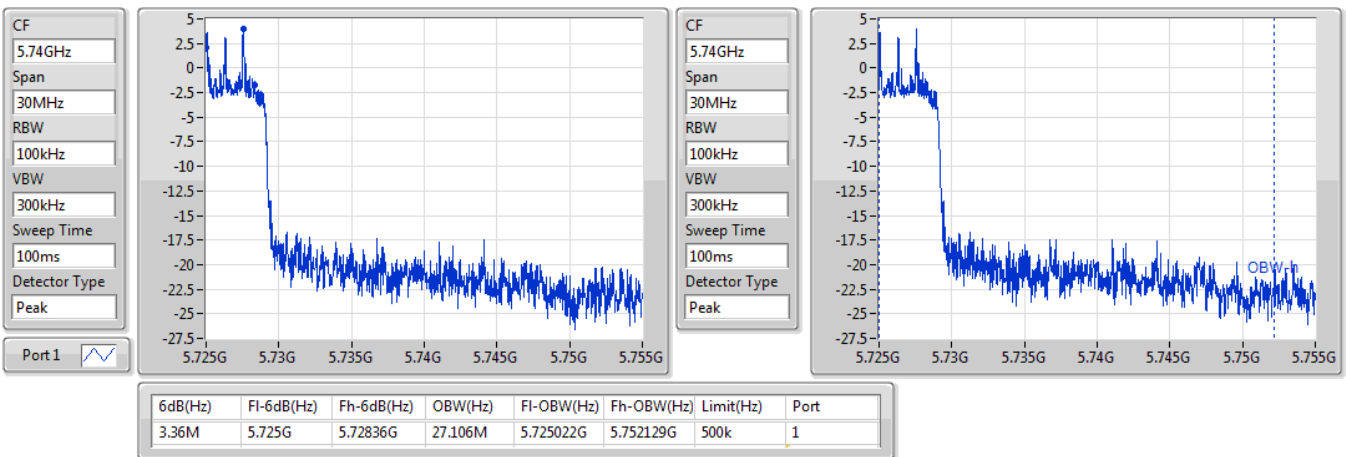



Summary

Mode	Max-N dB (Hz)	Max-OBW (Hz)	ITU-Code	Min-N dB (Hz)	Min-OBW (Hz)
5.25-5.35GHz	-	-	-	-	-
802.11a_Nss1,(6Mbps)_2TX	26.97M	16.942M	16M9D1D	24.36M	16.852M
802.11ac VHT20_Nss2,(MCS0)_2TX	35.73M	18.681M	18M7D1D	23.13M	17.931M
802.11ac VHT40_Nss2,(MCS0)_2TX	76.68M	38.381M	38M4D1D	40.26M	36.402M
802.11ac VHT80_Nss2,(MCS0)_2TX	90M	75.922M	75M9D1D	84.12M	75.802M
802.11ax HEW20_Nss2,(MCS0)_2TX	40.59M	19.34M	19M3D1D	24.48M	19.1M
802.11ax HEW40_Nss2,(MCS0)_2TX	77.58M	38.501M	38M5D1D	55.02M	37.781M
802.11ax HEW80_Nss2,(MCS0)_2TX	84.72M	77.241M	77M2D1D	81.12M	77.121M
5.47-5.725GHz	-	-	-	-	-
802.11a_Nss1,(6Mbps)_2TX	24.54M	16.852M	16M9D1D	16.328M	13.363M
802.11ac VHT20_Nss2,(MCS0)_2TX	35.28M	18.381M	18M4D1D	21.57M	14.5M
802.11ac VHT40_Nss2,(MCS0)_2TX	70.5M	37.181M	37M2D1D	39.78M	33.583M
802.11ac VHT80_Nss2,(MCS0)_2TX	148.32M	76.882M	76M9D1D	81.6M	72.891M
802.11ax HEW20_Nss2,(MCS0)_2TX	40.56M	19.34M	19M3D1D	21.42M	14.675M
802.11ax HEW40_Nss2,(MCS0)_2TX	77.4M	38.141M	38M1D1D	39.9M	33.696M
802.11ax HEW80_Nss2,(MCS0)_2TX	145.32M	77.721M	77M7D1D	81.24M	73.511M
5.725-5.85GHz	-	-	-	-	-
802.11a_Nss1,(6Mbps)_2TX	3.21M	4.963M	4M96D1D	3.21M	4.948M
802.11ac VHT20_Nss2,(MCS0)_2TX	3.825M	9.655M	9M66D1D	3.825M	8.441M
802.11ac VHT40_Nss2,(MCS0)_2TX	3.195M	22.129M	22M1D1D	3.195M	21.634M
802.11ac VHT80_Nss2,(MCS0)_2TX	3.195M	24.423M	24M4D1D	3.195M	24.408M
802.11ax HEW20_Nss2,(MCS0)_2TX	4.5M	11.394M	11M4D1D	4.485M	9.85M
802.11ax HEW40_Nss2,(MCS0)_2TX	3.84M	22.414M	22M4D1D	3.765M	22.324M
802.11ax HEW80_Nss2,(MCS0)_2TX	3.36M	24.828M	24M8D1D	3.18M	24.798M

Max-N dB = Maximum 6dB down bandwidth for 5.725-5.85GHz band / Maximum 26dB down bandwidth for other band;

Max-OBW = Maximum 99% occupied bandwidth;

Min-N dB = Minimum 6dB down bandwidth for 5.725-5.85GHz band / Maximum 26dB down bandwidth for other band;

Min-OBW = Minimum 99% occupied bandwidth;



Result

Mode	Result	Limit (Hz)	Port 1-N dB (Hz)	Port 1-OBW (Hz)	Port 2-N dB (Hz)	Port 2-OBW (Hz)
802.11a_Nss1,(6Mbps)_2TX	-	-	-	-	-	-
5260MHz	Pass	Inf	26.4M	16.882M	24.36M	16.852M
5300MHz	Pass	Inf	26.82M	16.942M	25.98M	16.852M
5320MHz	Pass	Inf	26.97M	16.942M	24.54M	16.882M
5500MHz	Pass	Inf	21.57M	16.822M	24.54M	16.852M
5580MHz	Pass	Inf	21.69M	16.822M	24.33M	16.852M
5700MHz	Pass	Inf	21.21M	16.762M	21.39M	16.672M
5720MHz Straddle 5.47-5.725GHz	Pass	Inf	16.573M	13.363M	16.328M	13.398M
5720MHz Straddle 5.725-5.85GHz	Pass	500k	3.21M	4.963M	3.21M	4.948M
802.11ac VHT20_Nss2,(MCS0)_2TX	-	-	-	-	-	-
5260MHz	Pass	Inf	33.69M	18.561M	35.73M	18.291M
5300MHz	Pass	Inf	35.52M	18.681M	32.79M	18.411M
5320MHz	Pass	Inf	27.3M	18.081M	23.13M	17.931M
5500MHz	Pass	Inf	24.18M	17.991M	26.49M	18.021M
5580MHz	Pass	Inf	31.02M	18.291M	35.28M	18.381M
5700MHz	Pass	Inf	21.57M	17.901M	21.81M	17.811M
5720MHz Straddle 5.47-5.725GHz	Pass	Inf	22.68M	14.5M	24.535M	14.57M
5720MHz Straddle 5.725-5.85GHz	Pass	500k	3.825M	8.441M	3.825M	9.655M
802.11ac VHT40_Nss2,(MCS0)_2TX	-	-	-	-	-	-
5270MHz	Pass	Inf	76.68M	38.381M	71.76M	37.001M
5310MHz	Pass	Inf	51.9M	36.582M	40.26M	36.402M
5510MHz	Pass	Inf	39.78M	36.402M	40.02M	36.342M
5550MHz	Pass	Inf	66.3M	37.181M	70.5M	36.762M
5670MHz	Pass	Inf	59.34M	36.822M	57.24M	36.642M
5710MHz Straddle 5.47-5.725GHz	Pass	Inf	53.438M	34.22M	52.838M	33.583M
5710MHz Straddle 5.725-5.85GHz	Pass	500k	3.195M	22.129M	3.195M	21.634M
802.11ac VHT80_Nss2,(MCS0)_2TX	-	-	-	-	-	-
5290MHz	Pass	Inf	90M	75.802M	84.12M	75.922M
5530MHz	Pass	Inf	81.6M	75.802M	81.84M	75.802M
5610MHz	Pass	Inf	148.32M	76.882M	140.76M	76.762M
5690MHz Straddle 5.47-5.725GHz	Pass	Inf	110.205M	72.891M	104.625M	72.891M
5690MHz Straddle 5.725-5.85GHz	Pass	500k	3.195M	24.408M	3.195M	24.423M
802.11ax HEW20_Nss2,(MCS0)_2TX	-	-	-	-	-	-
5260MHz	Pass	Inf	36.27M	19.31M	40.59M	19.34M
5300MHz	Pass	Inf	33.93M	19.31M	39.45M	19.25M
5320MHz	Pass	Inf	24.48M	19.1M	27.33M	19.16M
5500MHz	Pass	Inf	21.63M	19.1M	26.52M	19.16M
5580MHz	Pass	Inf	35.46M	19.22M	40.56M	19.34M
5700MHz	Pass	Inf	21.66M	19.01M	21.42M	19.04M
5720MHz Straddle 5.47-5.725GHz	Pass	Inf	23.94M	14.745M	24.255M	14.675M
5720MHz Straddle 5.725-5.85GHz	Pass	500k	4.5M	9.85M	4.485M	11.394M
802.11ax HEW40_Nss2,(MCS0)_2TX	-	-	-	-	-	-
5270MHz	Pass	Inf	77.58M	38.501M	77.46M	38.201M
5310MHz	Pass	Inf	55.32M	37.781M	55.02M	37.781M



Mode	Result	Limit (Hz)	Port 1-N dB (Hz)	Port 1-OBW (Hz)	Port 2-N dB (Hz)	Port 2-OBW (Hz)
5510MHz	Pass	Inf	40.14M	37.661M	39.9M	37.601M
5550MHz	Pass	Inf	77.4M	38.141M	77.4M	38.141M
5670MHz	Pass	Inf	76.14M	38.081M	76.62M	37.841M
5710MHz Straddle 5.47-5.725GHz	Pass	Inf	52.538M	33.808M	53.213M	33.696M
5710MHz Straddle 5.725-5.85GHz	Pass	500k	3.765M	22.414M	3.84M	22.324M
802.11ax HEW80_Nss2,(MCS0)_2TX	-	-	-	-	-	-
5290MHz	Pass	Inf	81.12M	77.241M	84.72M	77.121M
5530MHz	Pass	Inf	81.24M	77.241M	81.24M	77.121M
5610MHz	Pass	Inf	130.44M	77.721M	145.32M	77.721M
5690MHz Straddle 5.47-5.725GHz	Pass	Inf	109.895M	73.511M	109.043M	73.588M
5690MHz Straddle 5.725-5.85GHz	Pass	500k	3.36M	24.828M	3.18M	24.798M

Port X-N dB = Port X 6dB down bandwidth for 5.725-5.85GHz band / 26dB down bandwidth for other band

Port X-OBW = Port X 99% occupied bandwidth;

802.11a_Nss1,(6Mbps)_2TX

EBW

5260MHz

17/01/2020

CF
5.26GHz
Span
60MHz
RBW
200kHz
VBW
1MHz
Sweep Time
100ms
Detector Type
Peak

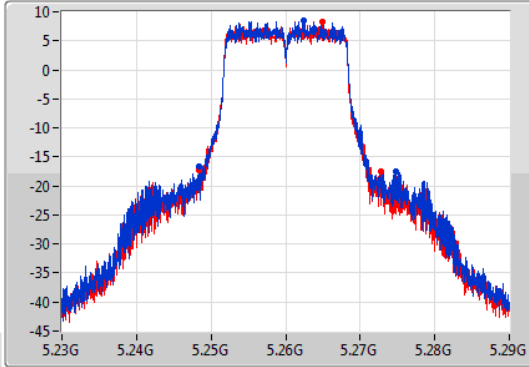

CF
5.26GHz
Span
60MHz
RBW
200kHz
VBW
1MHz
Sweep Time
100ms
Detector Type
Peak

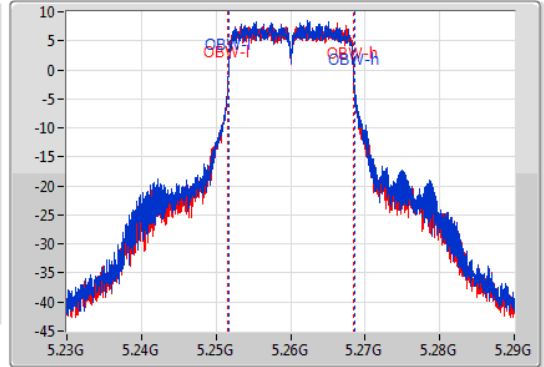

26dB(Hz)	Fl-26dB(Hz)	Fh-26dB(Hz)	OBW(Hz)	Fl-OBW(Hz)	Fh-OBW(Hz)	Limit(Hz)	Port
26.4M	5.24842G	5.27482G	16.882M	5.251664G	5.268546G	Inf	1
24.36M	5.24845G	5.27281G	16.852M	5.251634G	5.268486G	Inf	2

802.11a_Nss1,(6Mbps)_2TX

EBW

5300MHz

17/01/2020

CF
5.3GHz
Span
60MHz
RBW
200kHz
VBW
1MHz
Sweep Time
100ms
Detector Type
Peak

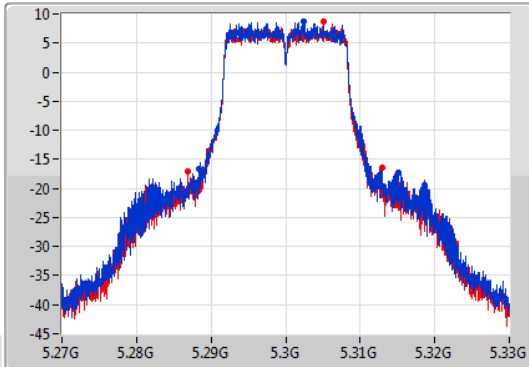

CF
5.3GHz
Span
60MHz
RBW
200kHz
VBW
1MHz
Sweep Time
100ms
Detector Type
Peak

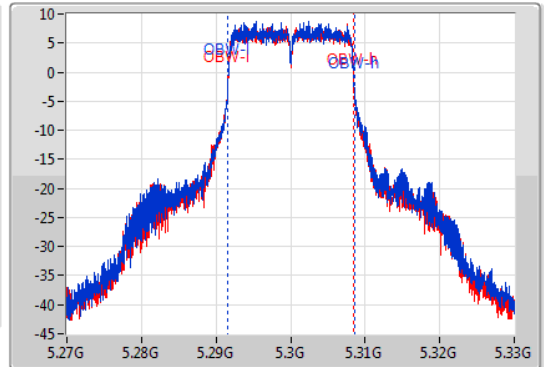

26dB(Hz)	Fl-26dB(Hz)	Fh-26dB(Hz)	OBW(Hz)	Fl-OBW(Hz)	Fh-OBW(Hz)	Limit(Hz)	Port
26.82M	5.28833G	5.31515G	16.942M	5.291634G	5.308576G	Inf	1
25.98M	5.28689G	5.31287G	16.852M	5.291634G	5.308486G	Inf	2

802.11a_Nss1,(6Mbps)_2TX

EBW

5320MHz

17/01/2020

CF
5.32GHz
Span
60MHz
RBW
200kHz
VBW
1MHz
Sweep Time
100ms
Detector Type
Peak

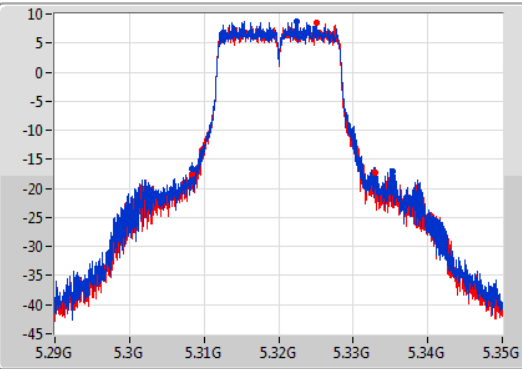

CF
5.32GHz
Span
60MHz
RBW
200kHz
VBW
1MHz
Sweep Time
100ms
Detector Type
Peak

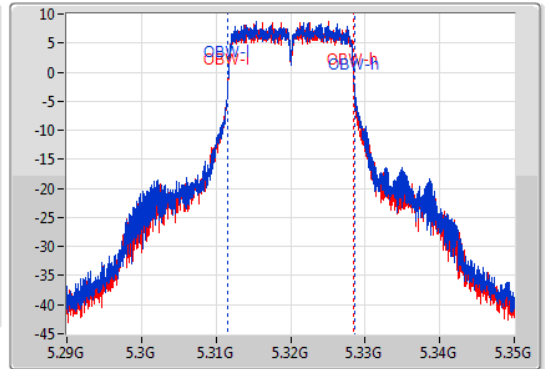

26dB(Hz)	Fl-26dB(Hz)	Fh-26dB(Hz)	OBW(Hz)	Fl-OBW(Hz)	Fh-OBW(Hz)	Limit(Hz)	Port
26.97M	5.30833G	5.3353G	16.942M	5.311634G	5.328576G	Inf	1
24.54M	5.30839G	5.33293G	16.882M	5.311604G	5.328486G	Inf	2

802.11a_Nss1,(6Mbps)_2TX

EBW

5500MHz

17/01/2020

CF
5.5GHz
Span
60MHz
RBW
200kHz
VBW
1MHz
Sweep Time
100ms
Detector Type
Peak

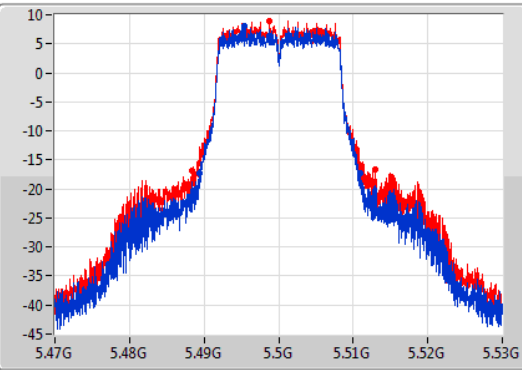

CF
5.5GHz
Span
60MHz
RBW
200kHz
VBW
1MHz
Sweep Time
100ms
Detector Type
Peak

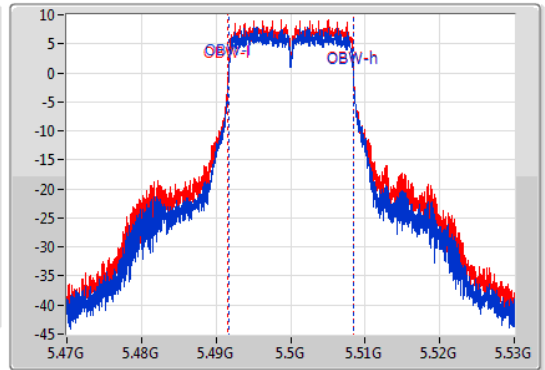

26dB(Hz)	Fl-26dB(Hz)	Fh-26dB(Hz)	OBW(Hz)	Fl-OBW(Hz)	Fh-OBW(Hz)	Limit(Hz)	Port
21.57M	5.48935G	5.51092G	16.822M	5.491664G	5.508486G	Inf	1
24.54M	5.48839G	5.51293G	16.852M	5.491634G	5.508486G	Inf	2

802.11a_Nss1,(6Mbps)_2TX

EBW

5580MHz

17/01/2020

CF
5.58GHz
Span
60MHz
RBW
200kHz
VBW
1MHz
Sweep Time
100ms
Detector Type
Peak

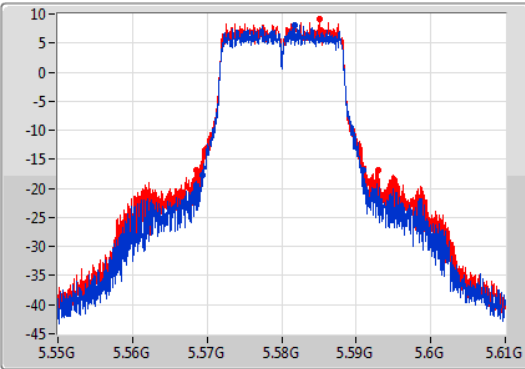

CF
5.58GHz
Span
60MHz
RBW
200kHz
VBW
1MHz
Sweep Time
100ms
Detector Type
Peak

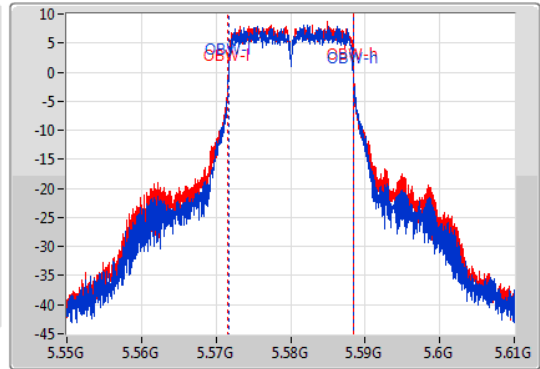

26dB(Hz)	Fl-26dB(Hz)	Fh-26dB(Hz)	OBW(Hz)	Fl-OBW(Hz)	Fh-OBW(Hz)	Limit(Hz)	Port
21.69M	5.56932G	5.59101G	16.822M	5.571694G	5.588516G	Inf	1
24.33M	5.56857G	5.5929G	16.852M	5.571634G	5.588486G	Inf	2

802.11a_Nss2,(6Mbps)_2TX

EBW

5700MHz

07/01/2020

CF
5.7GHz
Span
60MHz
RBW
200kHz
VBW
1MHz
Sweep Time
100ms
Detector Type
Peak

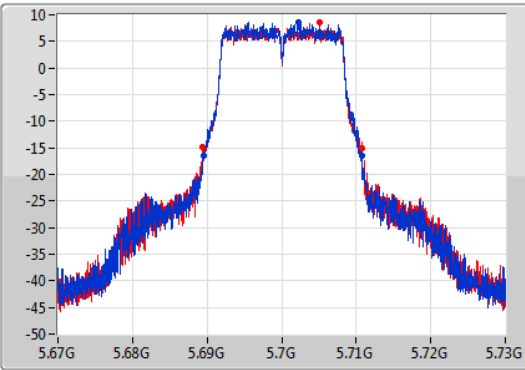

CF
5.7GHz
Span
60MHz
RBW
200kHz
VBW
1MHz
Sweep Time
100ms
Detector Type
Peak

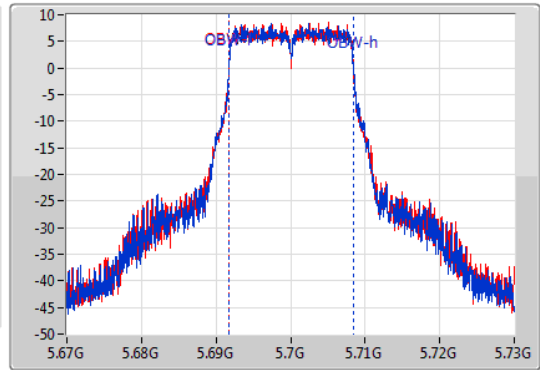

26dB(Hz)	Fl-26dB(Hz)	Fh-26dB(Hz)	OBW(Hz)	Fl-OBW(Hz)	Fh-OBW(Hz)	Limit(Hz)	Port
21.21M	5.6895G	5.71071G	16.762M	5.691724G	5.708486G	Inf	1
21.39M	5.68944G	5.71083G	16.672M	5.691754G	5.708426G	Inf	2

802.11a_Nss1,(6Mbps)_2TX

EBW

5720MHz Straddle 5.47-5.725GHz

17/01/2020

CF: 5.7075GHz
 Span: 35MHz
 RBW: 200kHz
 VBW: 1MHz
 Sweep Time: 100ms
 Detector Type: Peak
 Port 1: [Waveform icon]
 Port 2: [Waveform icon]

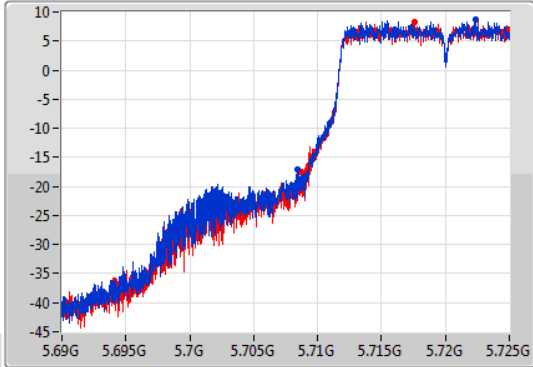

CF: 5.7075GHz
 Span: 35MHz
 RBW: 200kHz
 VBW: 1MHz
 Sweep Time: 100ms
 Detector Type: Peak

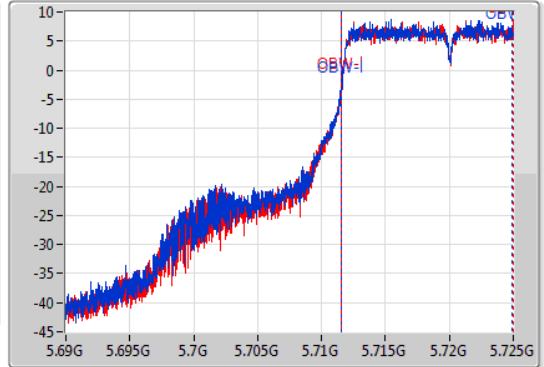

26dB(Hz)	Fl-26dB(Hz)	Fh-26dB(Hz)	OBW(Hz)	Fl-OBW(Hz)	Fh-OBW(Hz)	Limit(Hz)	Port
16.573M	5.708428G	5.725G	13.363M	5.711558G	5.724921G	Inf	1
16.328M	5.708673G	5.725G	13.398M	5.711558G	5.724956G	Inf	2

802.11a_Nss1,(6Mbps)_2TX

EBW

5720MHz Straddle 5.725-5.85GHz

17/01/2020

CF: 5.74GHz
 Span: 30MHz
 RBW: 100kHz
 VBW: 300kHz
 Sweep Time: 100ms
 Detector Type: Peak
 Port 1: [Waveform icon]
 Port 2: [Waveform icon]

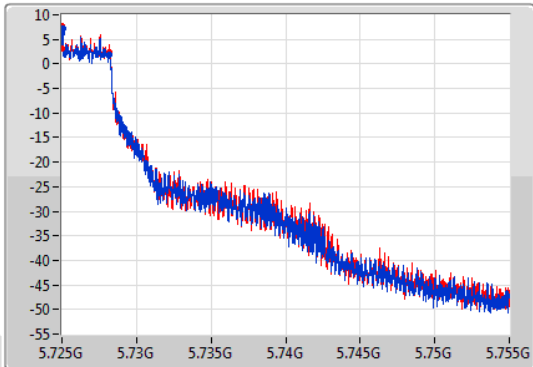

CF: 5.74GHz
 Span: 30MHz
 RBW: 100kHz
 VBW: 300kHz
 Sweep Time: 100ms
 Detector Type: Peak

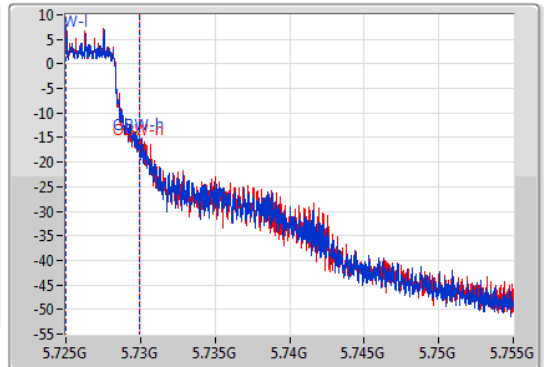

6dB(Hz)	Fl-6dB(Hz)	Fh-6dB(Hz)	OBW(Hz)	Fl-OBW(Hz)	Fh-OBW(Hz)	Limit(Hz)	Port
3.21M	5.725G	5.72821G	4.963M	5.725007G	5.72997G	500k	1
3.21M	5.725G	5.72821G	4.948M	5.725007G	5.729955G	500k	2

802.11ac VHT20_Nss2,(MCS0)_2TX

EBW

5260MHz

09/01/2020

CF
5.26GHz
Span
60MHz
RBW
200kHz
VBW
1MHz
Sweep Time
100ms
Detector Type
Peak

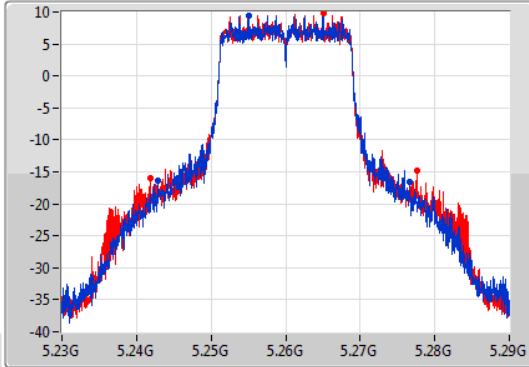

CF
5.26GHz
Span
60MHz
RBW
200kHz
VBW
1MHz
Sweep Time
100ms
Detector Type
Peak

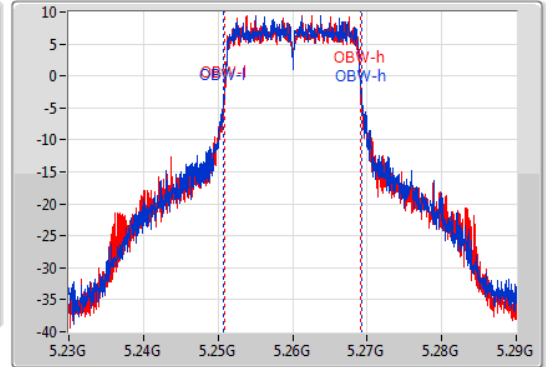

26dB(Hz)	Fl-26dB(Hz)	Fh-26dB(Hz)	OBW(Hz)	Fl-OBW(Hz)	Fh-OBW(Hz)	Limit(Hz)	Port
33.69M	5.24293G	5.27662G	18.561M	5.250765G	5.269325G	Inf	1
35.73M	5.24191G	5.27764G	18.291M	5.250855G	5.269145G	Inf	2

802.11ac VHT20_Nss2,(MCS0)_2TX

EBW

5300MHz

09/01/2020

CF
5.3GHz
Span
60MHz
RBW
200kHz
VBW
1MHz
Sweep Time
100ms
Detector Type
Peak

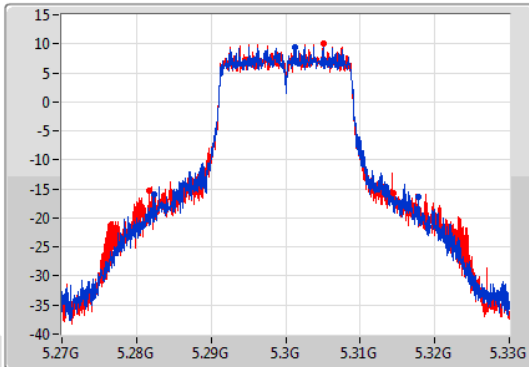

CF
5.3GHz
Span
60MHz
RBW
200kHz
VBW
1MHz
Sweep Time
100ms
Detector Type
Peak

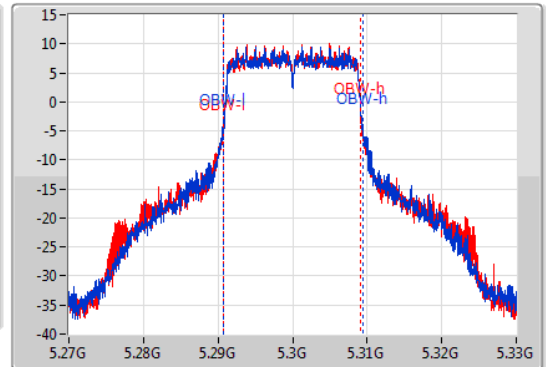

26dB(Hz)	Fl-26dB(Hz)	Fh-26dB(Hz)	OBW(Hz)	Fl-OBW(Hz)	Fh-OBW(Hz)	Limit(Hz)	Port
35.52M	5.28236G	5.31788G	18.681M	5.290705G	5.309385G	Inf	1
32.79M	5.28164G	5.31443G	18.411M	5.290765G	5.309175G	Inf	2

802.11ac VHT20_Nss2,(MCS0)_2TX

EBW

5320MHz

09/01/2020

CF
5.32GHz
Span
60MHz
RBW
200kHz
VBW
1MHz
Sweep Time
100ms
Detector Type
Peak

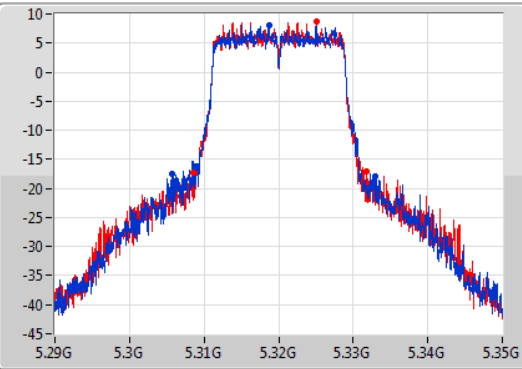

CF
5.32GHz
Span
60MHz
RBW
200kHz
VBW
1MHz
Sweep Time
100ms
Detector Type
Peak

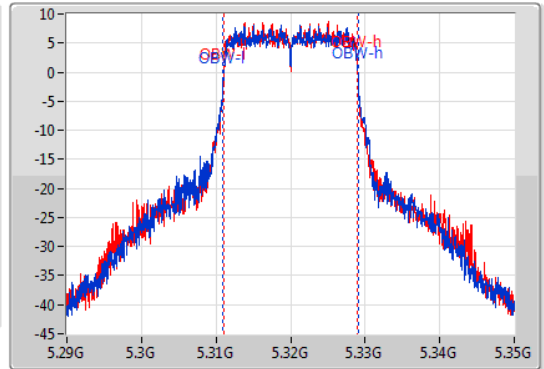

26dB(Hz)	Fl-26dB(Hz)	Fh-26dB(Hz)	OBW(Hz)	Fl-OBW(Hz)	Fh-OBW(Hz)	Limit(Hz)	Port
27.3M	5.30572G	5.33302G	18.081M	5.310975G	5.329055G	Inf	1
23.13M	5.3086G	5.33173G	17.931M	5.311064G	5.328996G	Inf	2

802.11ac VHT20_Nss2,(MCS0)_2TX

EBW

5500MHz

09/01/2020

CF
5.5GHz
Span
60MHz
RBW
200kHz
VBW
1MHz
Sweep Time
100ms
Detector Type
Peak

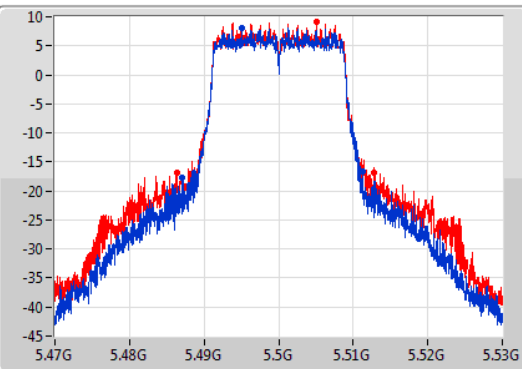

CF
5.5GHz
Span
60MHz
RBW
200kHz
VBW
1MHz
Sweep Time
100ms
Detector Type
Peak

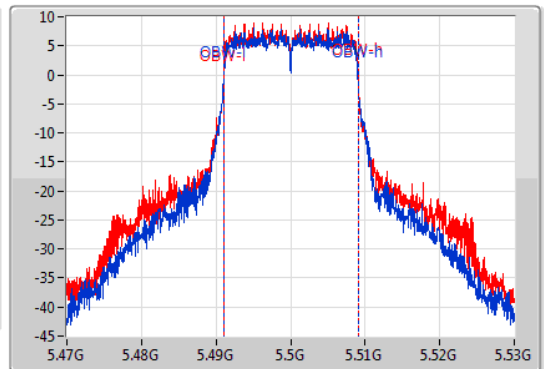

26dB(Hz)	Fl-26dB(Hz)	Fh-26dB(Hz)	OBW(Hz)	Fl-OBW(Hz)	Fh-OBW(Hz)	Limit(Hz)	Port
24.18M	5.48713G	5.51131G	17.991M	5.491034G	5.509025G	Inf	1
26.49M	5.48635G	5.51284G	18.021M	5.491004G	5.509025G	Inf	2

802.11ac VHT20_Nss2,(MCS0)_2TX

EBW

5580MHz

09/01/2020

CF
5.58GHz
Span
60MHz
RBW
200kHz
VBW
1MHz
Sweep Time
100ms
Detector Type
Peak

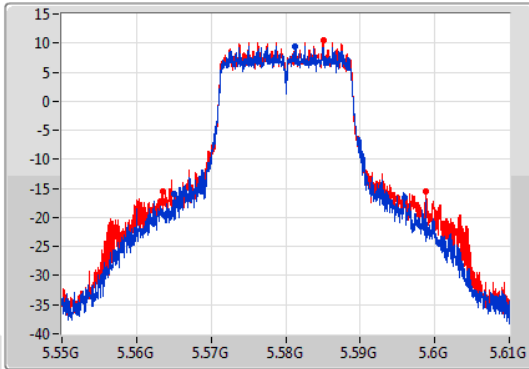

CF
5.58GHz
Span
60MHz
RBW
200kHz
VBW
1MHz
Sweep Time
100ms
Detector Type
Peak

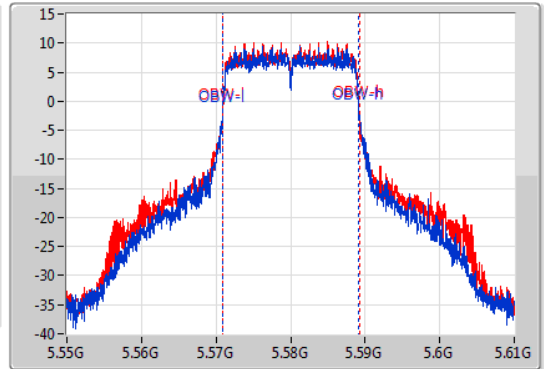

26dB(Hz)	Fl-26dB(Hz)	Fh-26dB(Hz)	OBW(Hz)	Fl-OBW(Hz)	Fh-OBW(Hz)	Limit(Hz)	Port
31.02M	5.565G	5.59602G	18.291M	5.570885G	5.589175G	Inf	1
35.28M	5.5635G	5.59878G	18.381M	5.570825G	5.589205G	Inf	2

802.11ac VHT20_Nss2,(MCS0)_2TX

EBW

5700MHz

09/01/2020

CF
5.7GHz
Span
60MHz
RBW
200kHz
VBW
1MHz
Sweep Time
100ms
Detector Type
Peak

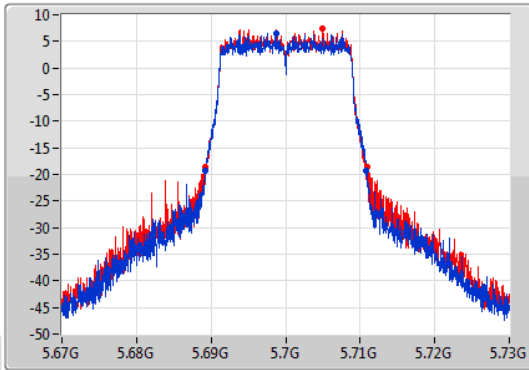

CF
5.7GHz
Span
60MHz
RBW
200kHz
VBW
1MHz
Sweep Time
100ms
Detector Type
Peak

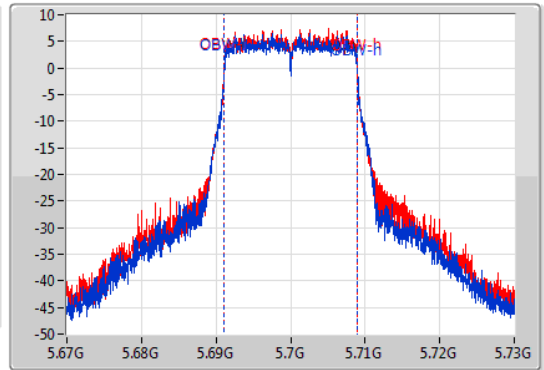

26dB(Hz)	Fl-26dB(Hz)	Fh-26dB(Hz)	OBW(Hz)	Fl-OBW(Hz)	Fh-OBW(Hz)	Limit(Hz)	Port
21.57M	5.68926G	5.71083G	17.901M	5.691094G	5.708996G	Inf	1
21.81M	5.6892G	5.71101G	17.811M	5.691124G	5.708936G	Inf	2

802.11ac VHT20_Nss2,(MCS0)_2TX

EBW

5720MHz Straddle 5.47-5.725GHz

09/01/2020

CF
5.7075GHz
Span
35MHz
RBW
200kHz
VBW
1MHz
Sweep Time
100ms
Detector Type
Peak

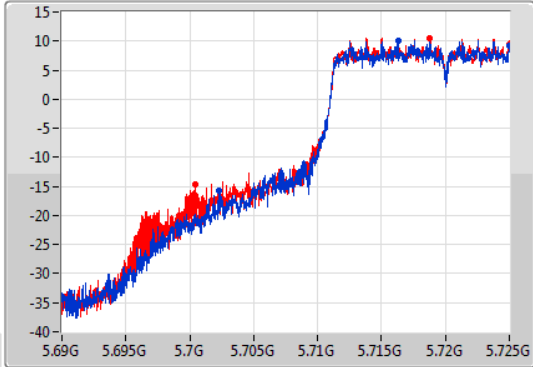

CF
5.7075GHz
Span
35MHz
RBW
200kHz
VBW
1MHz
Sweep Time
100ms
Detector Type
Peak

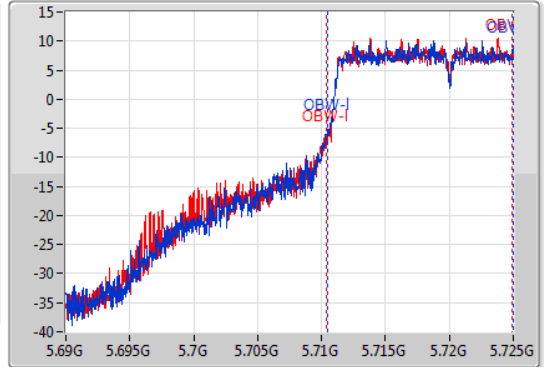

26dB(Hz)	Fl-26dB(Hz)	Fh-26dB(Hz)	OBW(Hz)	Fl-OBW(Hz)	Fh-OBW(Hz)	Limit(Hz)	Port
22.68M	5.70232G	5.725G	14.5M	5.710456G	5.724956G	Inf	1
24.535M	5.700465G	5.725G	14.57M	5.710369G	5.724939G	Inf	2

802.11ac VHT20_Nss2,(MCS0)_2TX

EBW

5720MHz Straddle 5.725-5.85GHz

09/01/2020

CF
5.74GHz
Span
30MHz
RBW
100kHz
VBW
300kHz
Sweep Time
100ms
Detector Type
Peak

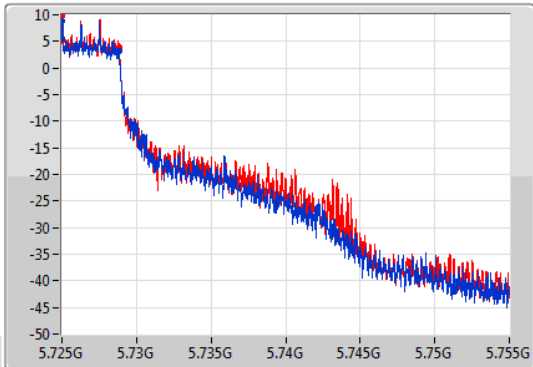

CF
5.74GHz
Span
30MHz
RBW
100kHz
VBW
300kHz
Sweep Time
100ms
Detector Type
Peak

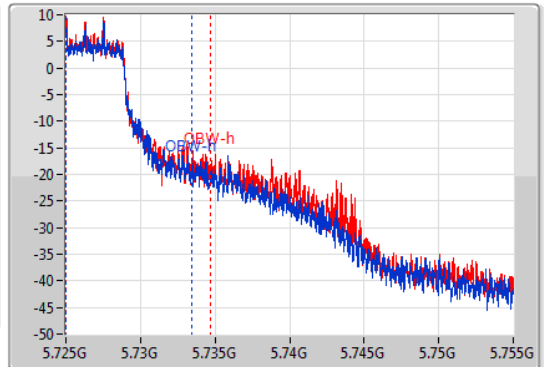

6dB(Hz)	Fl-6dB(Hz)	Fh-6dB(Hz)	OBW(Hz)	Fl-OBW(Hz)	Fh-OBW(Hz)	Limit(Hz)	Port
3.825M	5.725G	5.728825G	8.441M	5.725007G	5.733448G	500k	1
3.825M	5.725G	5.728825G	9.655M	5.725007G	5.734663G	500k	2

802.11ac VHT40_Nss2,(MCS0)_2TX

EBW

5270MHz

09/01/2020

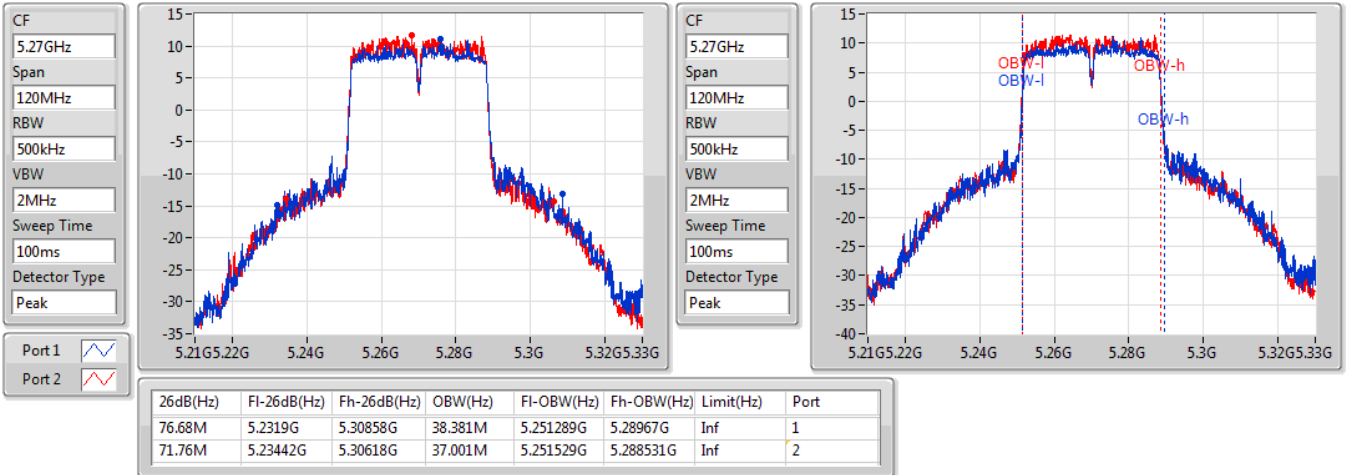

802.11ac VHT40_Nss2,(MCS0)_2TX

EBW

5310MHz

09/01/2020

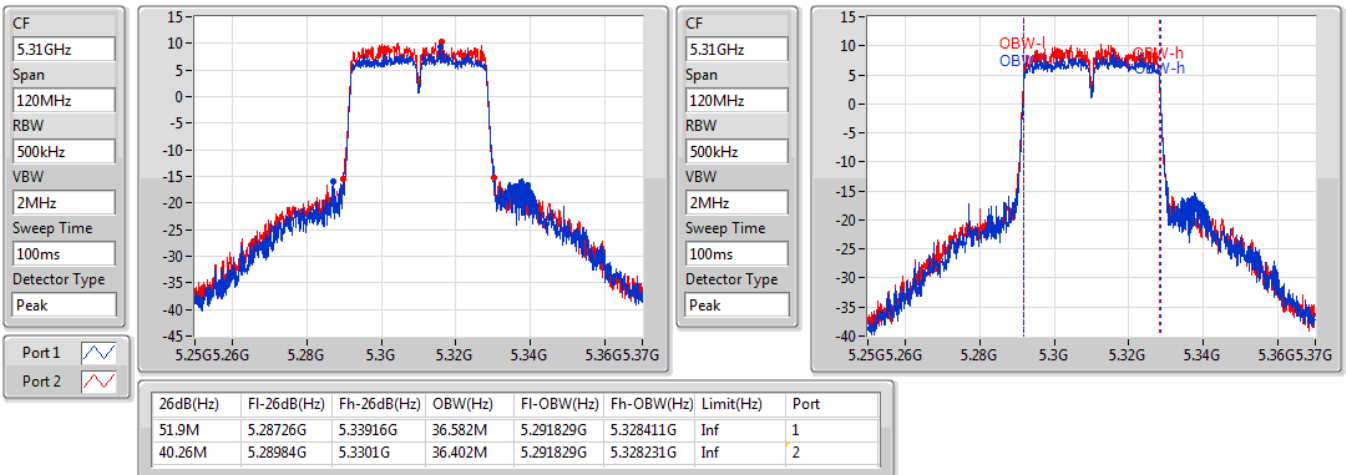

802.11ac VHT40_Nss2,(MCS0)_2TX

EBW

5510MHz

09/01/2020

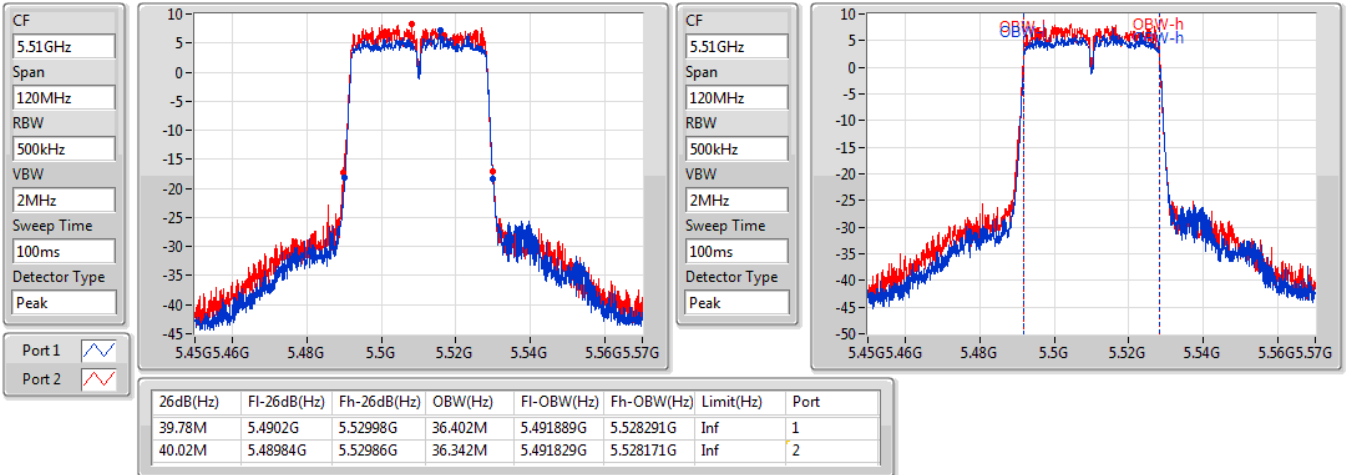

802.11ac VHT40_Nss2,(MCS0)_2TX

EBW

5550MHz

09/01/2020

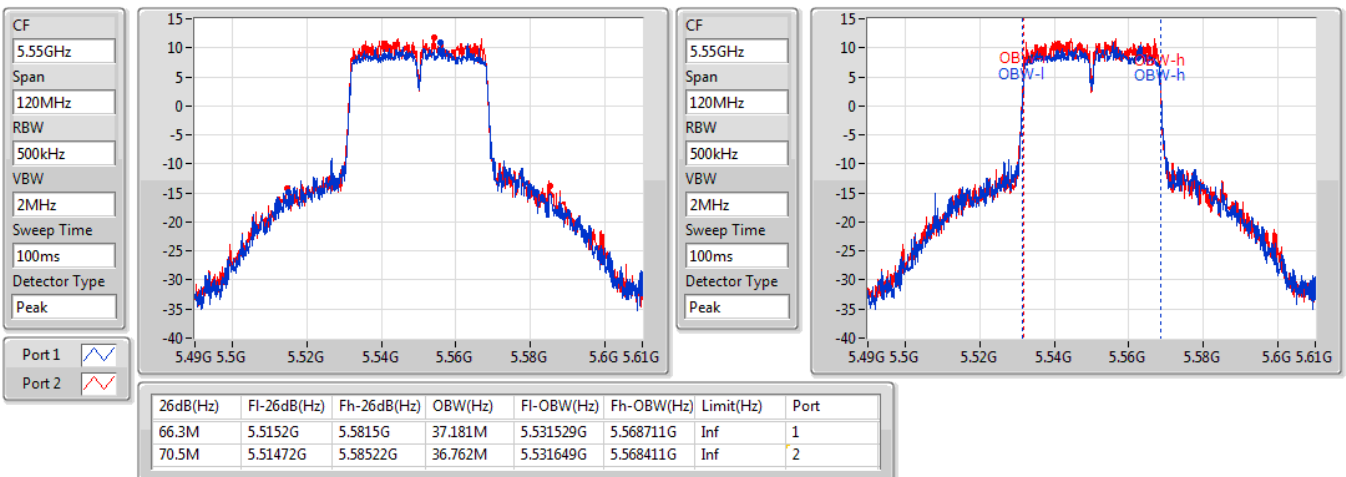

802.11ac VHT40_Nss2,(MCS0)_2TX

EBW

5670MHz

09/01/2020

CF
5.67GHz
Span
120MHz
RBW
500kHz
VBW
2MHz
Sweep Time
100ms
Detector Type
Peak

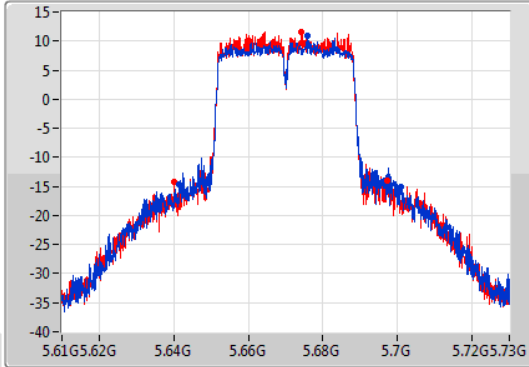

CF
5.67GHz
Span
120MHz
RBW
500kHz
VBW
2MHz
Sweep Time
100ms
Detector Type
Peak

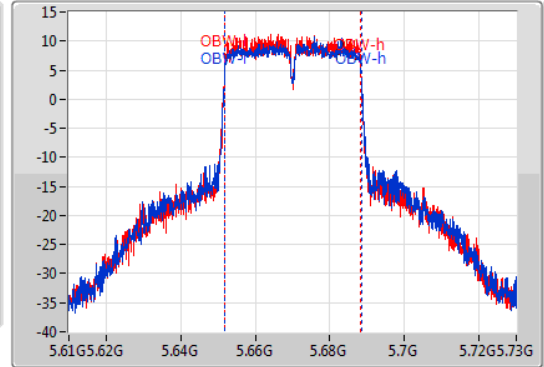

26dB(Hz)	Fl-26dB(Hz)	Fh-26dB(Hz)	OBW(Hz)	Fl-OBW(Hz)	Fh-OBW(Hz)	Limit(Hz)	Port
59.34M	5.6415G	5.70084G	36.822M	5.651709G	5.688531G	Inf	1
57.24M	5.64006G	5.6973G	36.642M	5.651709G	5.688351G	Inf	2

802.11ac VHT40_Nss2,(MCS0)_2TX

EBW

5710MHz Straddle 5.47-5.725GHz

09/01/2020

CF
5.6875GHz
Span
75MHz
RBW
500kHz
VBW
2MHz
Sweep Time
100ms
Detector Type
Peak

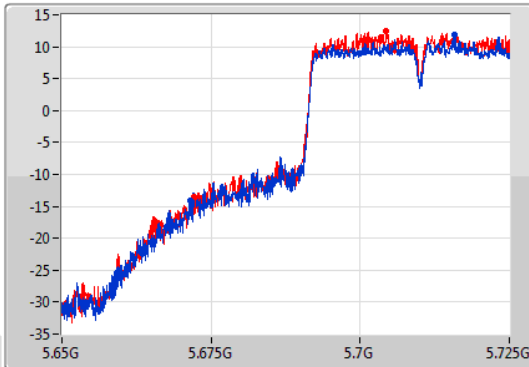

CF
5.6875GHz
Span
75MHz
RBW
500kHz
VBW
2MHz
Sweep Time
100ms
Detector Type
Peak

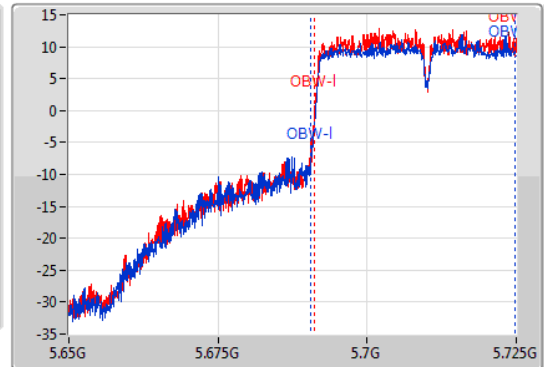

26dB(Hz)	Fl-26dB(Hz)	Fh-26dB(Hz)	OBW(Hz)	Fl-OBW(Hz)	Fh-OBW(Hz)	Limit(Hz)	Port
53.438M	5.671563G	5.725G	34.22M	5.690573G	5.724794G	Inf	1
52.838M	5.672163G	5.725G	33.583M	5.691248G	5.724831G	Inf	2

802.11ac VHT40_Nss2,(MCS0)_2TX

EBW

5710MHz Straddle 5.725-5.85GHz

09/01/2020

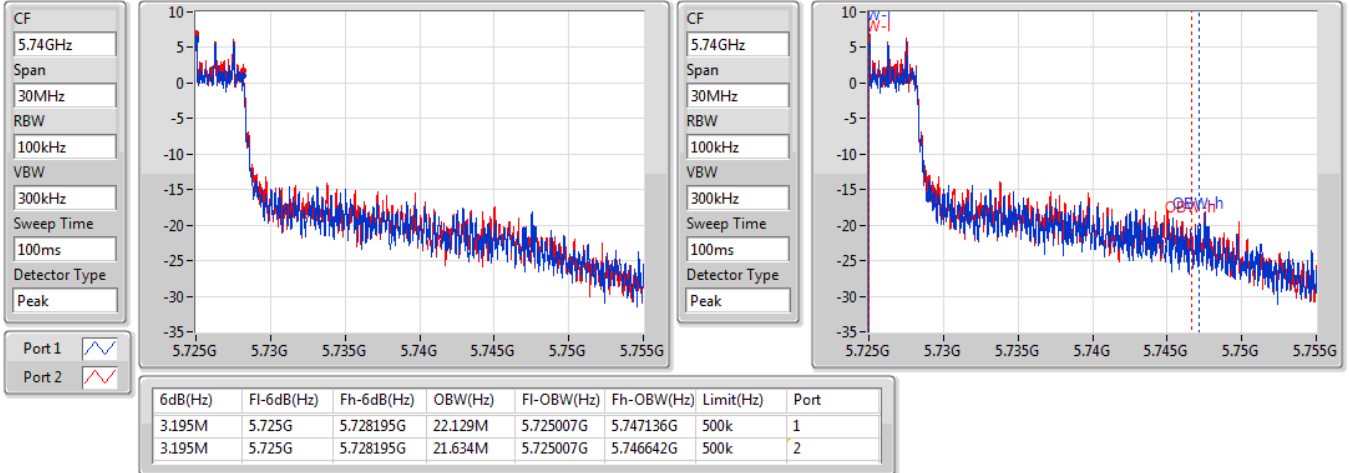

802.11ac VHT80_Nss2,(MCS0)_2TX

EBW

5290MHz

09/01/2020

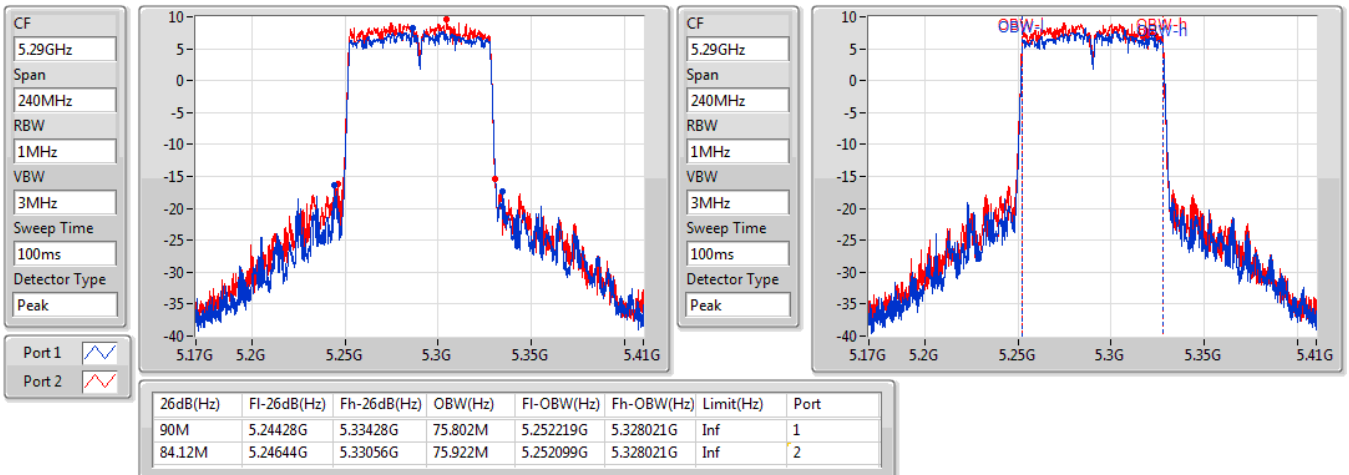

802.11ac VHT80_Nss2,(MCS0)_2TX

EBW

5530MHz

09/01/2020

CF
5.53GHz
Span
240MHz
RBW
1MHz
VBW
3MHz
Sweep Time
100ms
Detector Type
Peak

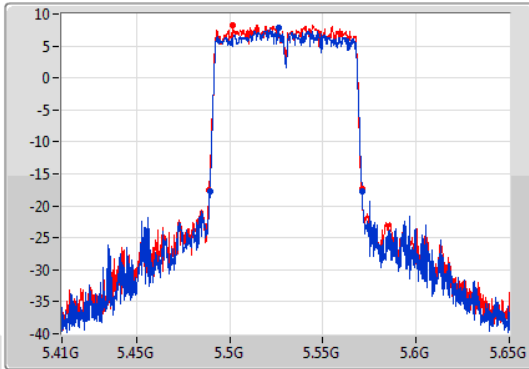

CF
5.53GHz
Span
240MHz
RBW
1MHz
VBW
3MHz
Sweep Time
100ms
Detector Type
Peak

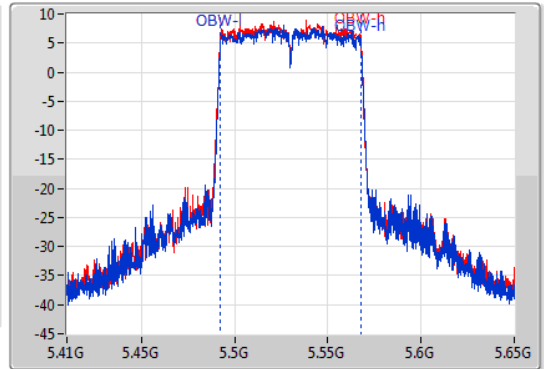

26dB(Hz)	Fl-26dB(Hz)	Fh-26dB(Hz)	OBW(Hz)	Fl-OBW(Hz)	Fh-OBW(Hz)	Limit(Hz)	Port
81.6M	5.48932G	5.57092G	75.802M	5.492219G	5.568021G	Inf	1
81.84M	5.48896G	5.5708G	75.802M	5.492099G	5.567901G	Inf	2

802.11ac VHT80_Nss2,(MCS0)_2TX

EBW

5610MHz

09/01/2020

CF
5.61GHz
Span
240MHz
RBW
1MHz
VBW
3MHz
Sweep Time
100ms
Detector Type
Peak

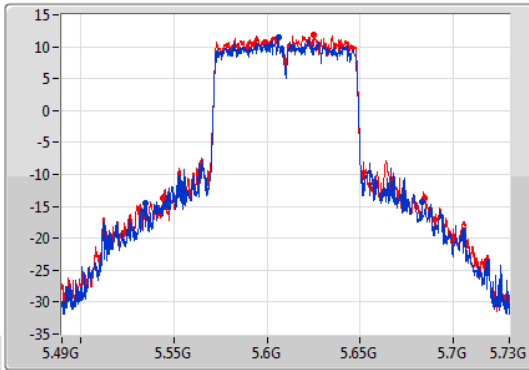

CF
5.61GHz
Span
240MHz
RBW
1MHz
VBW
3MHz
Sweep Time
100ms
Detector Type
Peak

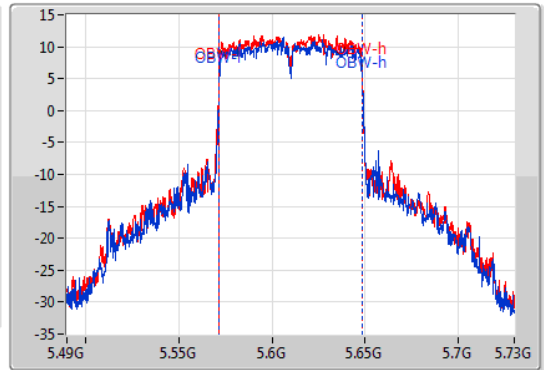

26dB(Hz)	Fl-26dB(Hz)	Fh-26dB(Hz)	OBW(Hz)	Fl-OBW(Hz)	Fh-OBW(Hz)	Limit(Hz)	Port
148.32M	5.53464G	5.68296G	76.882M	5.571739G	5.648621G	Inf	1
140.76M	5.54388G	5.68464G	76.762M	5.571739G	5.648501G	Inf	2

802.11ac VHT80_Nss2,(MCS0)_2TX

EBW

5690MHz Straddle 5.47-5.725GHz

09/01/2020

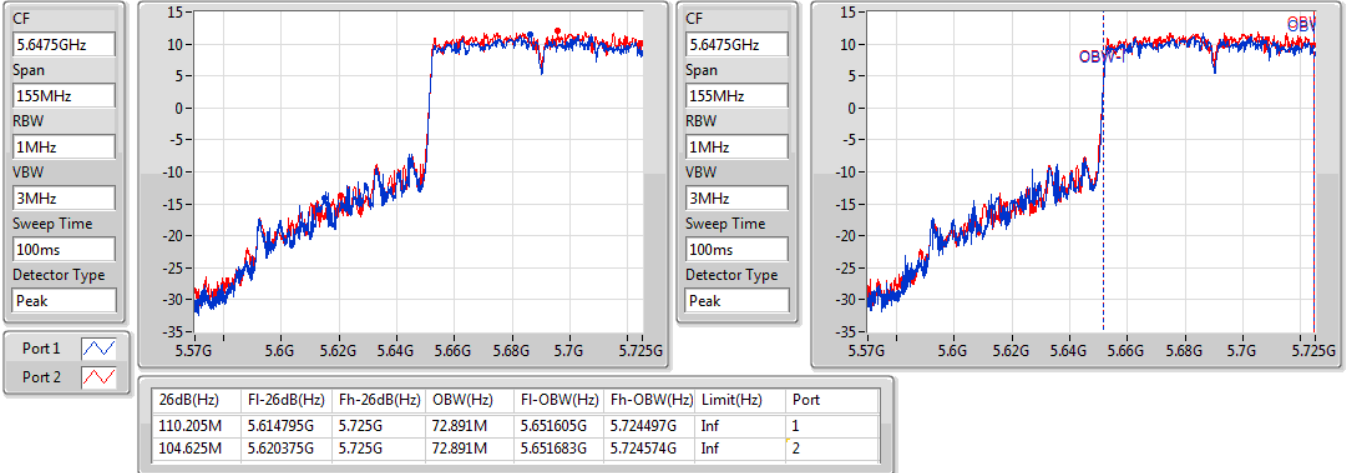

802.11ac VHT80_Nss2,(MCS0)_2TX

EBW

5690MHz Straddle 5.725-5.85GHz

09/01/2020

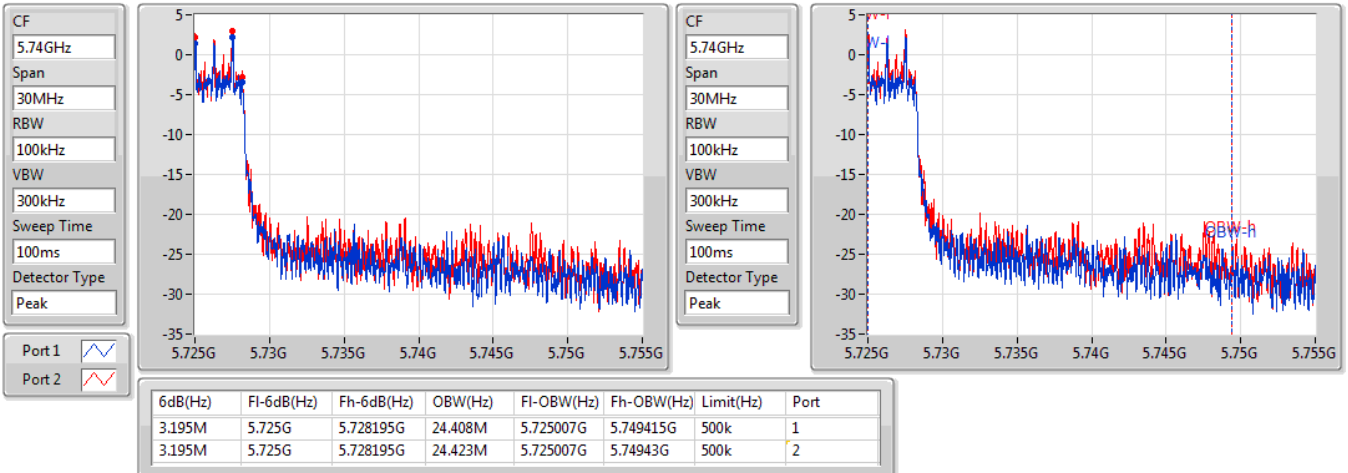

802.11ax HEW20_Nss2,(MCS0)_2TX

EBW

5260MHz

09/01/2020

CF
5.26GHz
Span
60MHz
RBW
200kHz
VBW
1MHz
Sweep Time
100ms
Detector Type
Peak

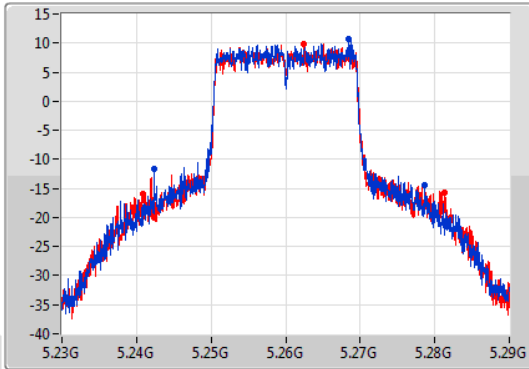

CF
5.26GHz
Span
60MHz
RBW
200kHz
VBW
1MHz
Sweep Time
100ms
Detector Type
Peak

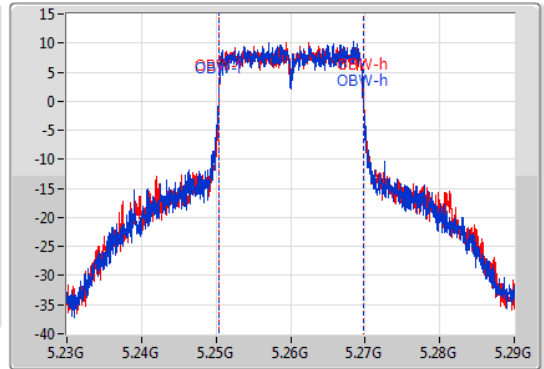

26dB(Hz)	Fl-26dB(Hz)	Fh-26dB(Hz)	OBW(Hz)	Fl-OBW(Hz)	Fh-OBW(Hz)	Limit(Hz)	Port
36.27M	5.24242G	5.27869G	19.31M	5.250405G	5.269715G	Inf	1
40.59M	5.2408G	5.28139G	19.34M	5.250435G	5.269775G	Inf	2

802.11ax HEW20_Nss2,(MCS0)_2TX

EBW

5300MHz

09/01/2020

CF
5.3GHz
Span
60MHz
RBW
200kHz
VBW
1MHz
Sweep Time
100ms
Detector Type
Peak

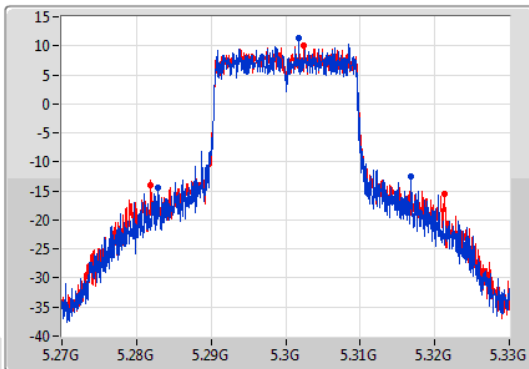

CF
5.3GHz
Span
60MHz
RBW
200kHz
VBW
1MHz
Sweep Time
100ms
Detector Type
Peak

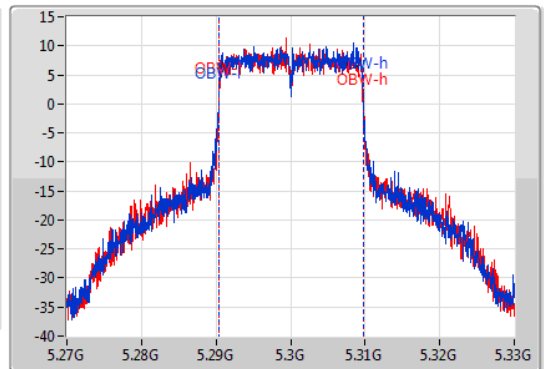

26dB(Hz)	Fl-26dB(Hz)	Fh-26dB(Hz)	OBW(Hz)	Fl-OBW(Hz)	Fh-OBW(Hz)	Limit(Hz)	Port
33.93M	5.28287G	5.3168G	19.31M	5.290405G	5.309715G	Inf	1
39.45M	5.28191G	5.32136G	19.25M	5.290465G	5.309715G	Inf	2

802.11ax HEW20_Nss2,(MCS0)_2TX

EBW

5320MHz

09/01/2020

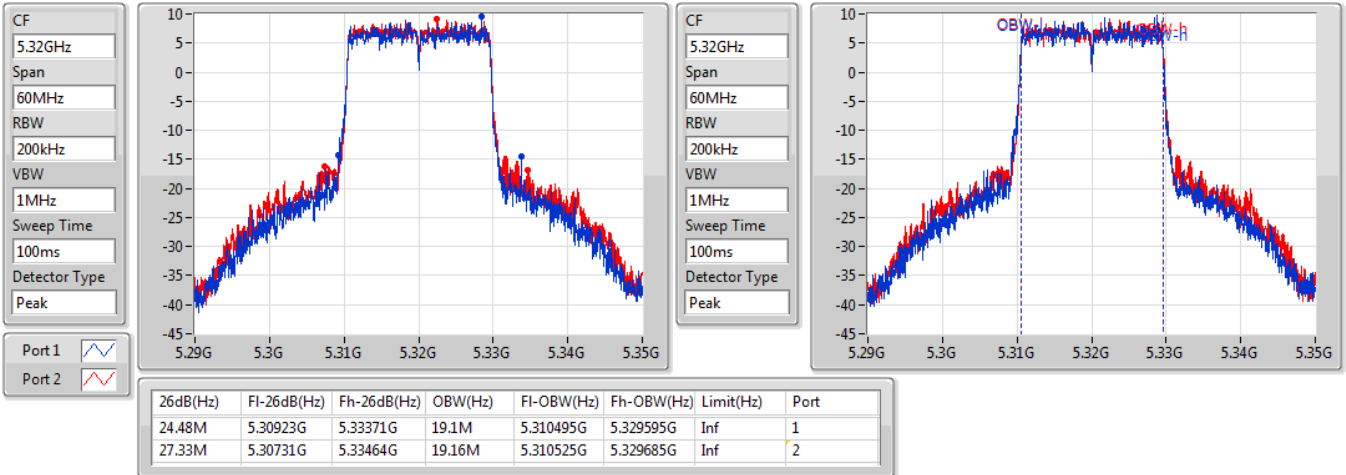

802.11ax HEW20_Nss2,(MCS0)_2TX

EBW

5500MHz

09/01/2020

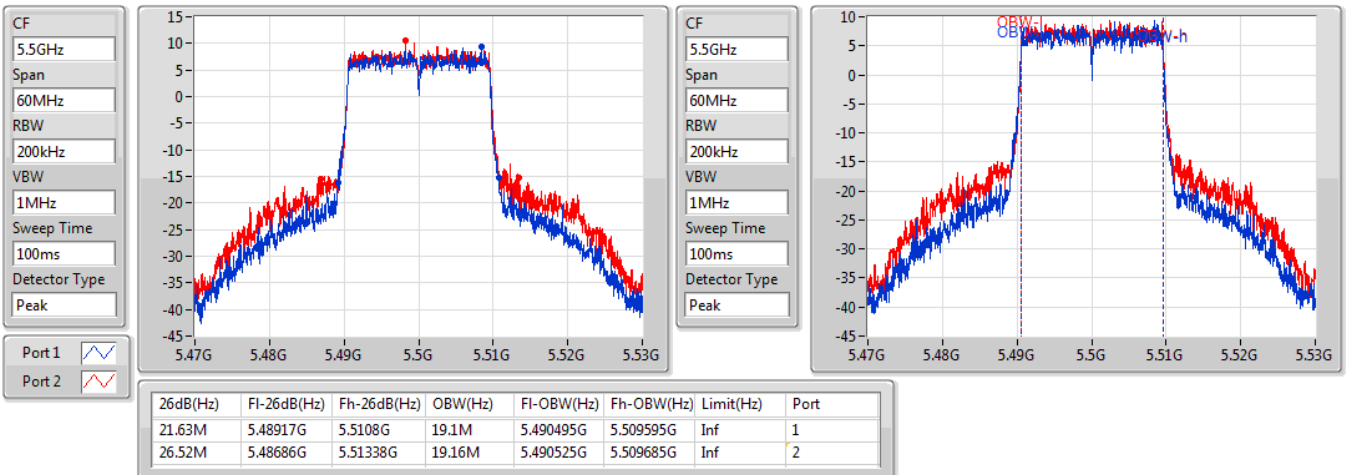

802.11ax HEW20_Nss2,(MCS0)_2TX

EBW

5580MHz

09/01/2020

CF
5.58GHz
Span
60MHz
RBW
200kHz
VBW
1MHz
Sweep Time
100ms
Detector Type
Peak

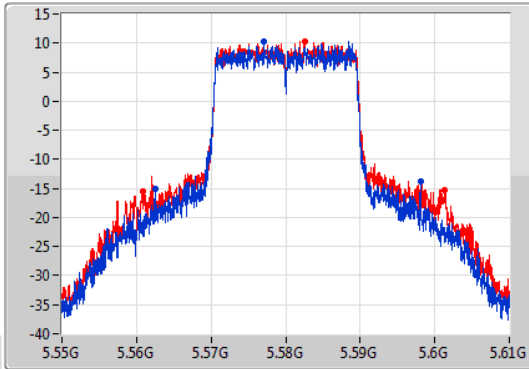

CF
5.58GHz
Span
60MHz
RBW
200kHz
VBW
1MHz
Sweep Time
100ms
Detector Type
Peak

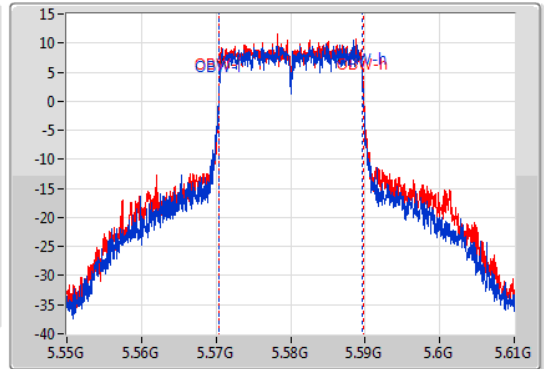

26dB(Hz)	Fl-26dB(Hz)	Fh-26dB(Hz)	OBW(Hz)	Fl-OBW(Hz)	Fh-OBW(Hz)	Limit(Hz)	Port
35.46M	5.5626G	5.59806G	19.22M	5.570435G	5.589655G	Inf	1
40.56M	5.56083G	5.60139G	19.34M	5.570435G	5.589775G	Inf	2

802.11ax HEW20_Nss2,(MCS0)_2TX

EBW

5700MHz

09/01/2020

CF
5.7GHz
Span
60MHz
RBW
200kHz
VBW
1MHz
Sweep Time
100ms
Detector Type
Peak

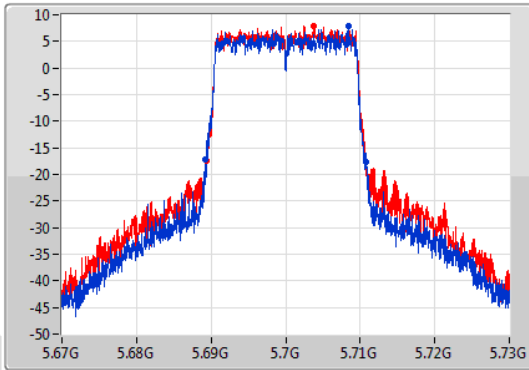

CF
5.7GHz
Span
60MHz
RBW
200kHz
VBW
1MHz
Sweep Time
100ms
Detector Type
Peak

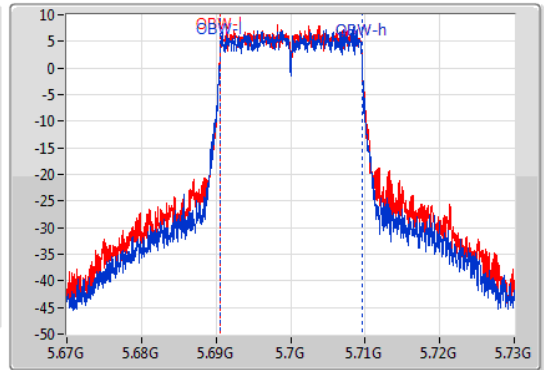

26dB(Hz)	Fl-26dB(Hz)	Fh-26dB(Hz)	OBW(Hz)	Fl-OBW(Hz)	Fh-OBW(Hz)	Limit(Hz)	Port
21.66M	5.68917G	5.71083G	19.01M	5.690525G	5.709535G	Inf	1
21.42M	5.68938G	5.7108G	19.04M	5.690555G	5.709595G	Inf	2

802.11ax HEW20_Nss2,(MCS0)_2TX

EBW

5720MHz Straddle 5.47-5.725GHz

09/01/2020

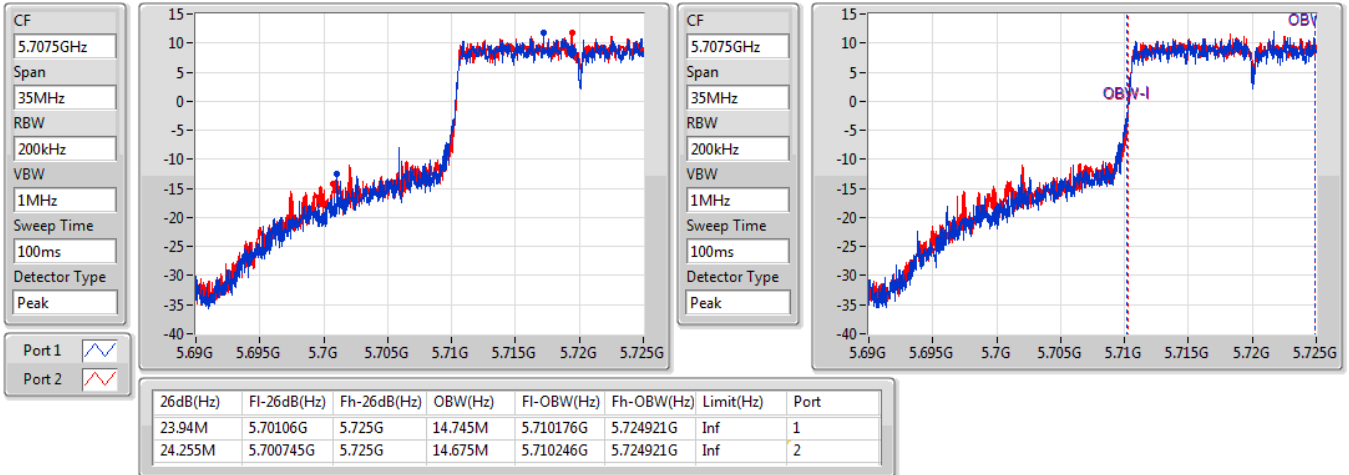

802.11ax HEW20_Nss2,(MCS0)_2TX

EBW

5720MHz Straddle 5.725-5.85GHz

09/01/2020

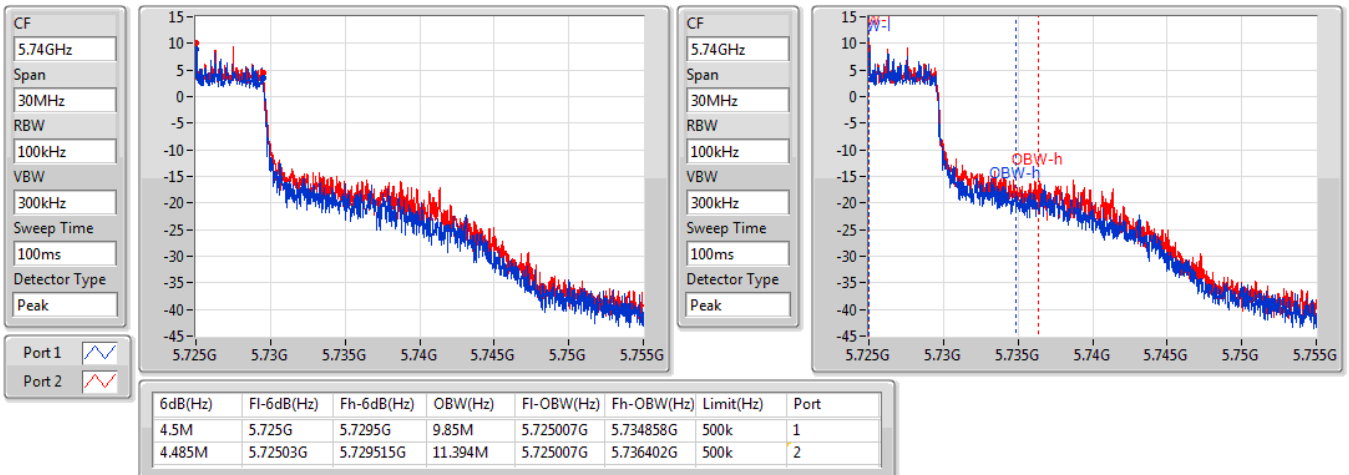

802.11ax HEW40_Nss2,(MCS0)_2TX

EBW

5270MHz

09/01/2020

CF
5.27GHz
Span
120MHz
RBW
500kHz
VBW
2MHz
Sweep Time
100ms
Detector Type
Peak

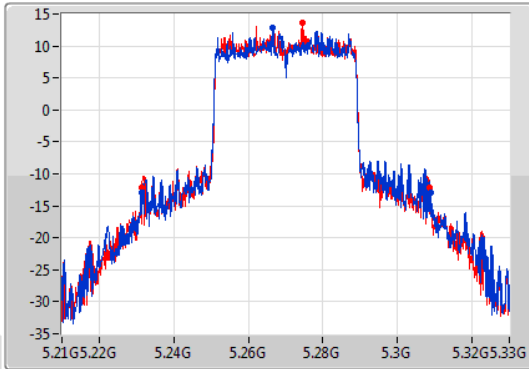

CF
5.27GHz
Span
120MHz
RBW
500kHz
VBW
2MHz
Sweep Time
100ms
Detector Type
Peak

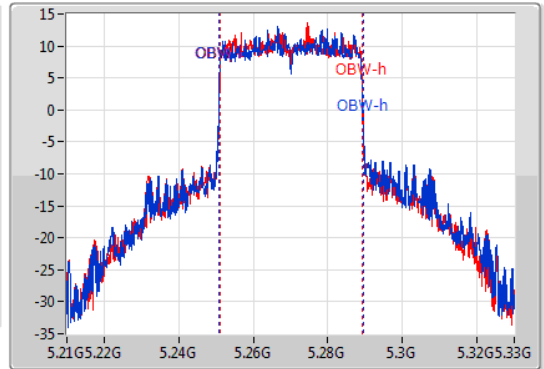

26dB(Hz)	Fl-26dB(Hz)	Fh-26dB(Hz)	OBW(Hz)	Fl-OBW(Hz)	Fh-OBW(Hz)	Limit(Hz)	Port
77.58M	5.23124G	5.30882G	38.501M	5.25093G	5.28943G	Inf	1
77.46M	5.2313G	5.30876G	38.201M	5.251049G	5.28925G	Inf	2

802.11ax HEW40_Nss2,(MCS0)_2TX

EBW

5310MHz

09/01/2020

CF
5.31GHz
Span
120MHz
RBW
500kHz
VBW
2MHz
Sweep Time
100ms
Detector Type
Peak

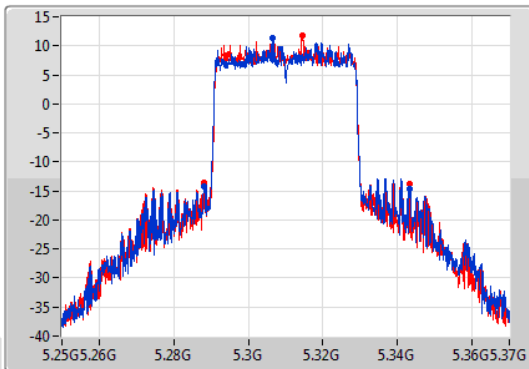

CF
5.31GHz
Span
120MHz
RBW
500kHz
VBW
2MHz
Sweep Time
100ms
Detector Type
Peak

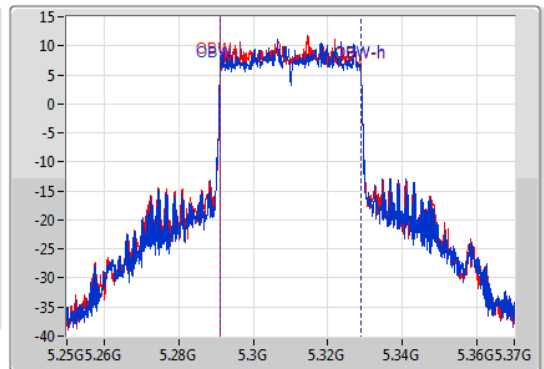

26dB(Hz)	Fl-26dB(Hz)	Fh-26dB(Hz)	OBW(Hz)	Fl-OBW(Hz)	Fh-OBW(Hz)	Limit(Hz)	Port
55.32M	5.2881G	5.34342G	37.781M	5.291109G	5.328891G	Inf	1
55.02M	5.28816G	5.34318G	37.781M	5.291169G	5.328951G	Inf	2

802.11ax HEW40_Nss2,(MCS0)_2TX

EBW

5510MHz

09/01/2020

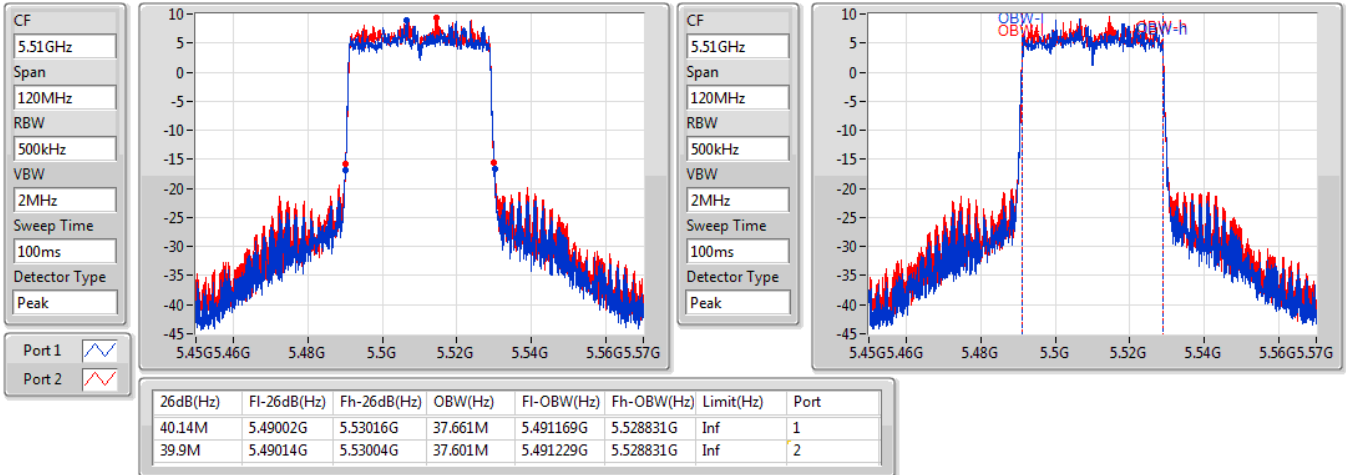

802.11ax HEW40_Nss2,(MCS0)_2TX

EBW

5550MHz

09/01/2020

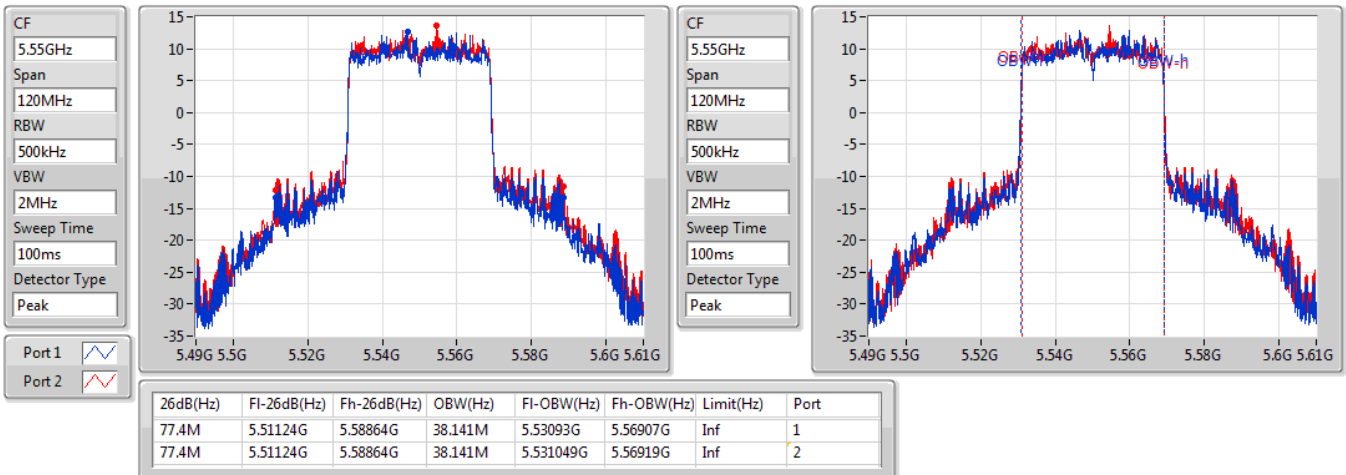

802.11ax HEW40_Nss2,(MCS0)_2TX

EBW

5670MHz

09/01/2020

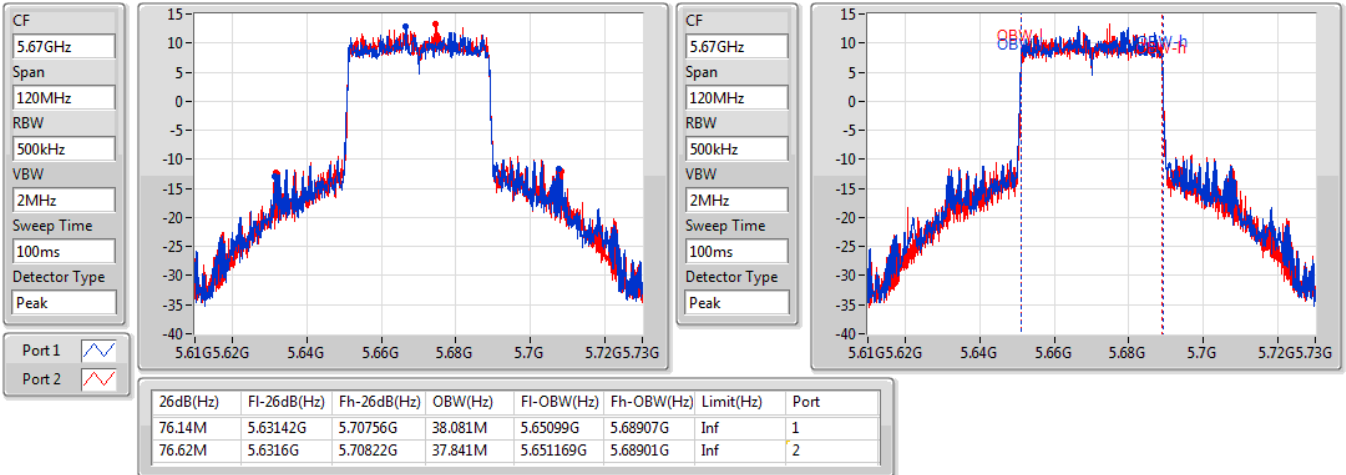

802.11ax HEW40_Nss2,(MCS0)_2TX

EBW

5710MHz Straddle 5.47-5.725GHz

09/01/2020

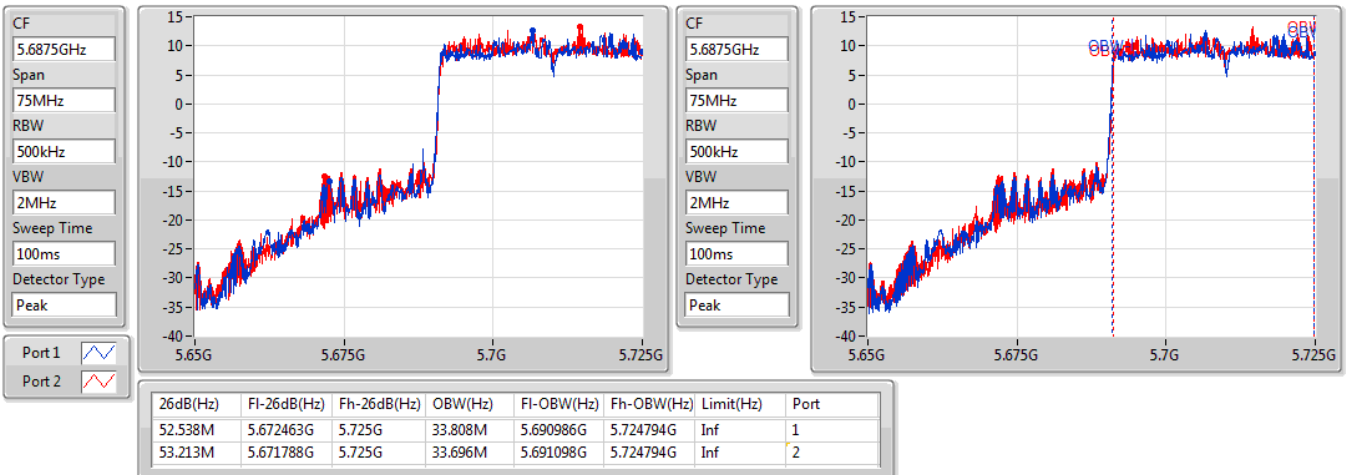

802.11ax HEW40_Nss2,(MCS0)_2TX

EBW

5710MHz Straddle 5.725-5.85GHz

09/01/2020

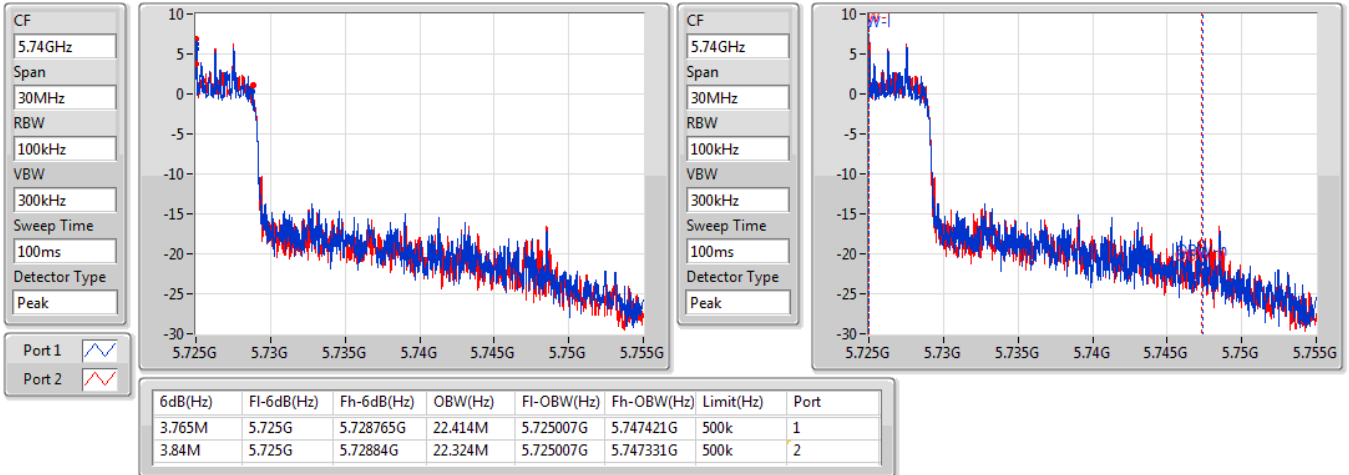

802.11ax HEW80_Nss2,(MCS0)_2TX

EBW

5290MHz

09/01/2020

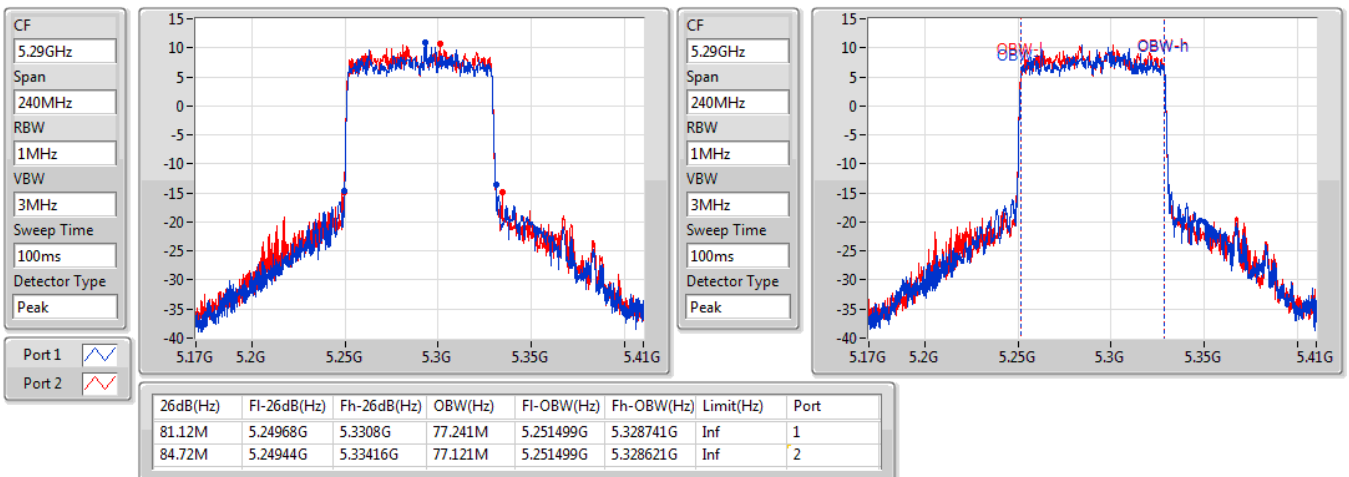

802.11ax HEW80_Nss2,(MCS0)_2TX

EBW

5530MHz

09/01/2020

CF
5.53GHz
Span
240MHz
RBW
1MHz
VBW
3MHz
Sweep Time
100ms
Detector Type
Peak
Port 1
Port 2

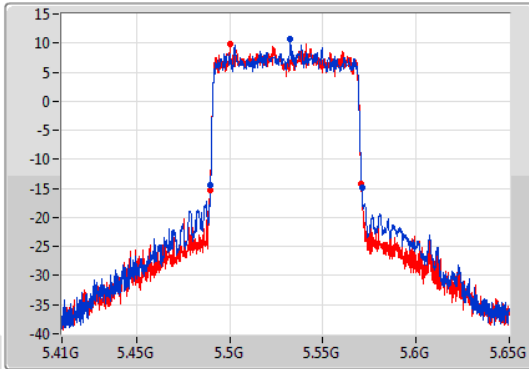

CF
5.53GHz
Span
240MHz
RBW
1MHz
VBW
3MHz
Sweep Time
100ms
Detector Type
Peak

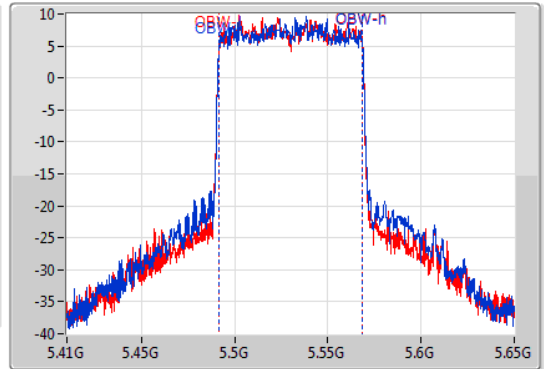

26dB(Hz)	Fl-26dB(Hz)	Fh-26dB(Hz)	OBW(Hz)	Fl-OBW(Hz)	Fh-OBW(Hz)	Limit(Hz)	Port
81.24M	5.48968G	5.57092G	77.241M	5.491499G	5.568741G	Inf	1
81.24M	5.48944G	5.57068G	77.121M	5.491499G	5.568621G	Inf	2

802.11ax HEW80_Nss2,(MCS0)_2TX

EBW

5610MHz

09/01/2020

CF
5.61GHz
Span
240MHz
RBW
1MHz
VBW
3MHz
Sweep Time
100ms
Detector Type
Peak
Port 1
Port 2

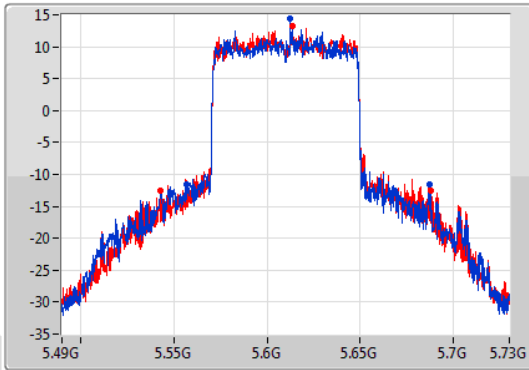

CF
5.61GHz
Span
240MHz
RBW
1MHz
VBW
3MHz
Sweep Time
100ms
Detector Type
Peak

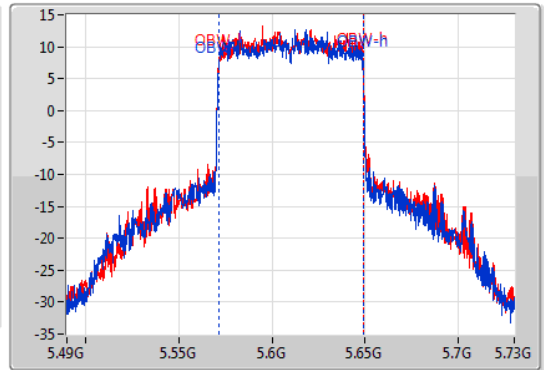

26dB(Hz)	Fl-26dB(Hz)	Fh-26dB(Hz)	OBW(Hz)	Fl-OBW(Hz)	Fh-OBW(Hz)	Limit(Hz)	Port
130.44M	5.55672G	5.68716G	77.721M	5.571259G	5.648981G	Inf	1
145.32M	5.54268G	5.688G	77.721M	5.571259G	5.648981G	Inf	2

802.11ax HEW80_Nss2,(MCS0)_2TX

EBW

5690MHz Straddle 5.47-5.725GHz

09/01/2020

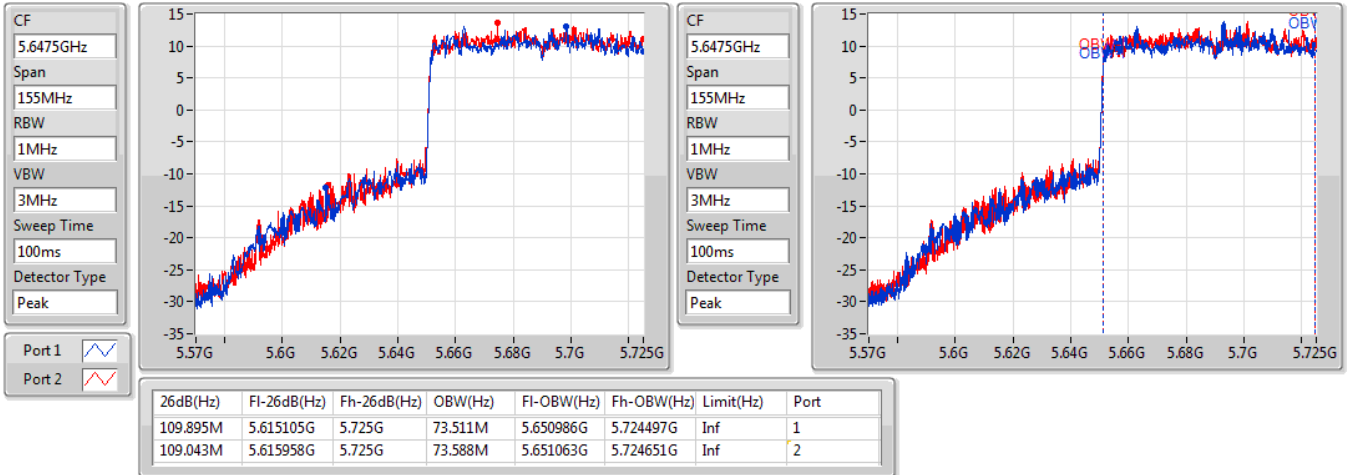

802.11ax HEW80_Nss2,(MCS0)_2TX

EBW

5690MHz Straddle 5.725-5.85GHz

09/01/2020

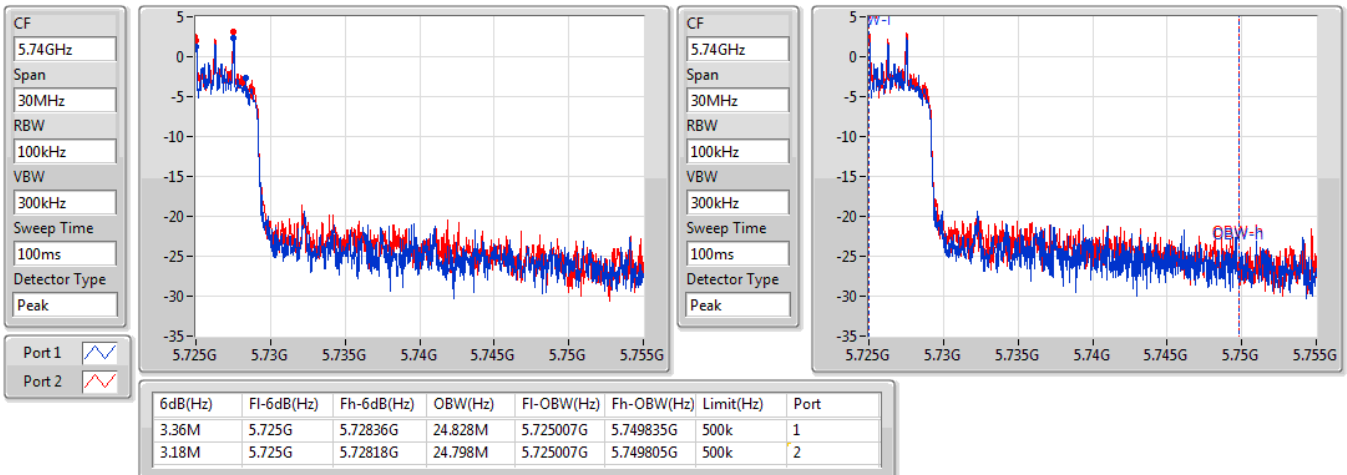



Summary

Mode	Max-N dB (Hz)	Max-OBW (Hz)	ITU-Code	Min-N dB (Hz)	Min-OBW (Hz)
5.25-5.35GHz	-	-	-	-	-
802.11a_Nss1,(6Mbps)_1TX	38.37M	18.861M	18M9D1D	21.51M	16.762M
802.11ac VHT20_Nss1,(MCS0)_1TX	39.6M	18.681M	18M7D1D	21.69M	17.871M
802.11ac VHT40_Nss1,(MCS0)_1TX	75.12M	37.121M	37M1D1D	41.16M	36.402M
802.11ac VHT80_Nss1,(MCS0)_1TX	83.4M	75.802M	75M8D1D	83.4M	75.802M
802.11ax HEW20_Nss1,(MCS0)_1TX	41.25M	19.7M	19M7D1D	21.87M	19.04M
802.11ax HEW40_Nss1,(MCS0)_1TX	75.36M	37.961M	38M0D1D	41.1M	37.481M
802.11ax HEW80_Nss1,(MCS0)_1TX	84.12M	77.121M	77M1D1D	84.12M	77.121M
5.47-5.725GHz	-	-	-	-	-
802.11a_Nss1,(6Mbps)_1TX	38.61M	18.771M	18M8D1D	21.51M	14.813M
802.11ac VHT20_Nss1,(MCS0)_1TX	36.09M	18.651M	18M7D1D	21.72M	14.468M
802.11ac VHT40_Nss1,(MCS0)_1TX	62.1M	36.702M	36M7D1D	41.22M	33.793M
802.11ac VHT80_Nss1,(MCS0)_1TX	105.225M	75.922M	75M9D1D	83.28M	72.864M
802.11ax HEW20_Nss1,(MCS0)_1TX	40.59M	19.67M	19M7D1D	21.63M	14.903M
802.11ax HEW40_Nss1,(MCS0)_1TX	56.875M	37.721M	37M7D1D	40.8M	34.108M
802.11ax HEW80_Nss1,(MCS0)_1TX	111.3M	77.121M	77M1D1D	83.88M	73.388M
5.725-5.85GHz	-	-	-	-	-
802.11a_Nss1,(6Mbps)_1TX	3.16M	9.315M	9M32D1D	3.16M	9.315M
802.11ac VHT20_Nss1,(MCS0)_1TX	3.78M	7.616M	7M62D1D	3.78M	7.616M
802.11ac VHT40_Nss1,(MCS0)_1TX	3.16M	21.169M	21M2D1D	3.16M	21.169M
802.11ac VHT80_Nss1,(MCS0)_1TX	3.16M	28.826M	28M8D1D	3.16M	28.826M
802.11ax HEW20_Nss1,(MCS0)_1TX	4.46M	10.035M	10M0D1D	4.46M	10.035M
802.11ax HEW40_Nss1,(MCS0)_1TX	3.78M	24.148M	24M1D1D	3.78M	24.148M
802.11ax HEW80_Nss1,(MCS0)_1TX	3.54M	31.484M	31M5D1D	3.54M	31.484M

Max-N dB = Maximum 6dB down bandwidth for 5.725-5.85GHz band / Maximum 26dB down bandwidth for other band;

Max-OBW = Maximum 99% occupied bandwidth;

Min-N dB = Minimum 6dB down bandwidth for 5.725-5.85GHz band / Maximum 26dB down bandwidth for other band;

Min-OBW = Minimum 99% occupied bandwidth;



Result

Mode	Result	Limit (Hz)	Port 1-N dB (Hz)	Port 1-OBW (Hz)
802.11a_Nss1,(6Mbps)_1TX	-	-	-	-
5260MHz	Pass	Inf	38.37M	18.741M
5300MHz	Pass	Inf	38.37M	18.861M
5320MHz	Pass	Inf	21.51M	16.762M
5500MHz	Pass	Inf	21.51M	16.732M
5580MHz	Pass	Inf	38.61M	18.771M
5700MHz	Pass	Inf	21.51M	16.762M
5720MHz Straddle 5.47-5.725GHz	Pass	Inf	23.94M	14.813M
5720MHz Straddle 5.725-5.85GHz	Pass	500k	3.16M	9.315M
802.11ac VHT20_Nss1,(MCS0)_1TX	-	-	-	-
5260MHz	Pass	Inf	39.6M	18.681M
5300MHz	Pass	Inf	37.38M	18.591M
5320MHz	Pass	Inf	21.69M	17.871M
5500MHz	Pass	Inf	21.72M	17.841M
5580MHz	Pass	Inf	36.09M	18.651M
5700MHz	Pass	Inf	21.75M	17.841M
5720MHz Straddle 5.47-5.725GHz	Pass	Inf	23.01M	14.468M
5720MHz Straddle 5.725-5.85GHz	Pass	500k	3.78M	7.616M
802.11ac VHT40_Nss1,(MCS0)_1TX	-	-	-	-
5270MHz	Pass	Inf	75.12M	37.121M
5310MHz	Pass	Inf	41.16M	36.402M
5510MHz	Pass	Inf	41.22M	36.402M
5550MHz	Pass	Inf	62.1M	36.702M
5670MHz	Pass	Inf	41.34M	36.402M
5710MHz Straddle 5.47-5.725GHz	Pass	Inf	58.555M	33.793M
5710MHz Straddle 5.725-5.85GHz	Pass	500k	3.16M	21.169M
802.11ac VHT80_Nss1,(MCS0)_1TX	-	-	-	-
5290MHz	Pass	Inf	83.4M	75.802M
5530MHz	Pass	Inf	83.28M	75.802M
5610MHz	Pass	Inf	83.28M	75.922M
5690MHz Straddle 5.47-5.725GHz	Pass	Inf	105.225M	72.864M
5690MHz Straddle 5.725-5.85GHz	Pass	500k	3.16M	28.826M
802.11ax HEW20_Nss1,(MCS0)_1TX	-	-	-	-
5260MHz	Pass	Inf	41.25M	19.7M
5300MHz	Pass	Inf	39.18M	19.49M
5320MHz	Pass	Inf	21.87M	19.04M
5500MHz	Pass	Inf	21.63M	19.04M
5580MHz	Pass	Inf	40.59M	19.67M
5700MHz	Pass	Inf	21.75M	19.01M
5720MHz Straddle 5.47-5.725GHz	Pass	Inf	25.47M	14.903M
5720MHz Straddle 5.725-5.85GHz	Pass	500k	4.46M	10.035M
802.11ax HEW40_Nss1,(MCS0)_1TX	-	-	-	-
5270MHz	Pass	Inf	75.36M	37.961M
5310MHz	Pass	Inf	41.1M	37.481M



Mode	Result	Limit (Hz)	Port 1-N dB (Hz)	Port 1-OBW (Hz)
5510MHz	Pass	Inf	40.98M	37.601M
5550MHz	Pass	Inf	50.94M	37.721M
5670MHz	Pass	Inf	40.8M	37.541M
5710MHz Straddle 5.47-5.725GHz	Pass	Inf	56.875M	34.108M
5710MHz Straddle 5.725-5.85GHz	Pass	500k	3.78M	24.148M
802.11ax HEW80_Nss1,(MCS0)_1TX	-	-	-	-
5290MHz	Pass	Inf	84.12M	77.121M
5530MHz	Pass	Inf	83.88M	77.121M
5610MHz	Pass	Inf	84.12M	77.121M
5690MHz Straddle 5.47-5.725GHz	Pass	Inf	111.3M	73.388M
5690MHz Straddle 5.725-5.85GHz	Pass	500k	3.54M	31.484M

Port X-N dB = Port X 6dB down bandwidth for 5.725-5.85GHz band / 26dB down bandwidth for other band

Port X-OBW = Port X 99% occupied bandwidth;

802.11a_Nss1,(6Mbps)_1TX

EBW

5260MHz

06/01/2020

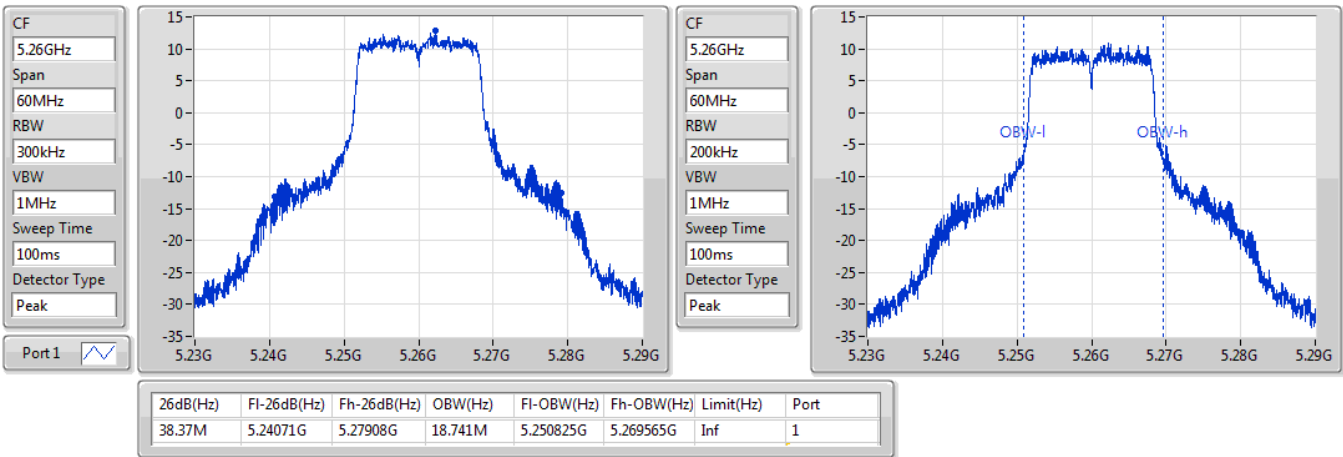

802.11a_Nss1,(6Mbps)_1TX

EBW

5300MHz

06/01/2020

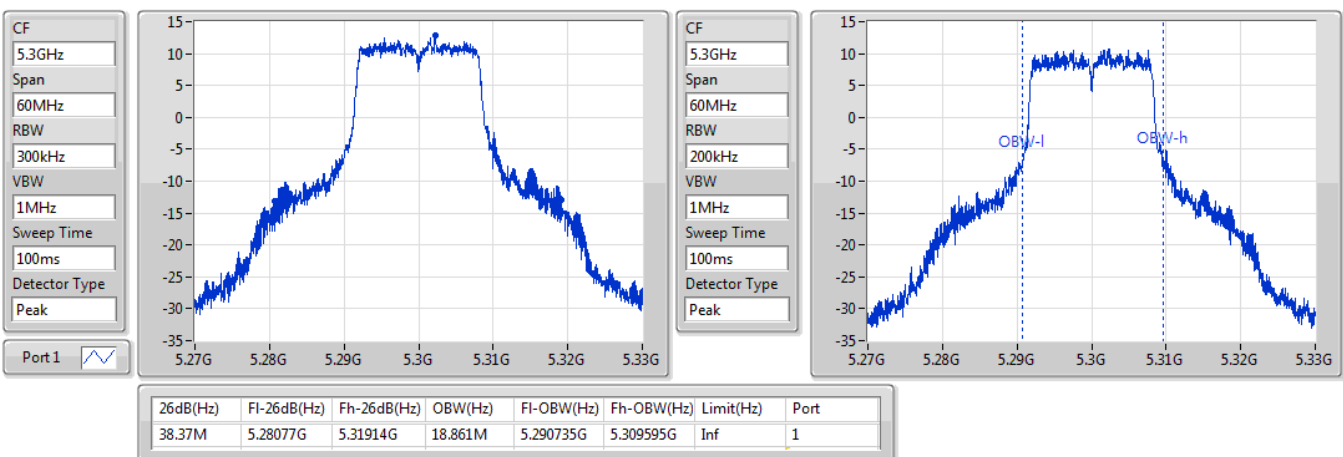

802.11a_Nss1,(6Mbps)_1TX

EBW

5320MHz

06/01/2020

CF: 5.32GHz
 Span: 60MHz
 RBW: 300kHz
 VBW: 1MHz
 Sweep Time: 100ms
 Detector Type: Peak
 Port 1

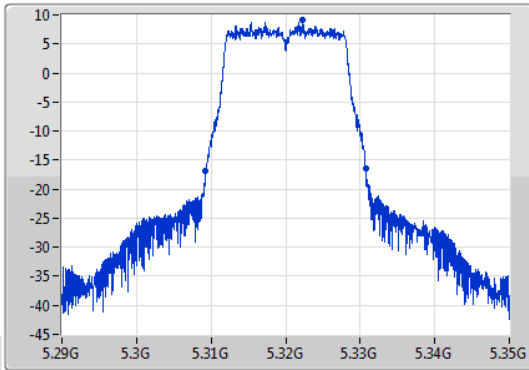

CF: 5.32GHz
 Span: 60MHz
 RBW: 200kHz
 VBW: 1MHz
 Sweep Time: 100ms
 Detector Type: Peak

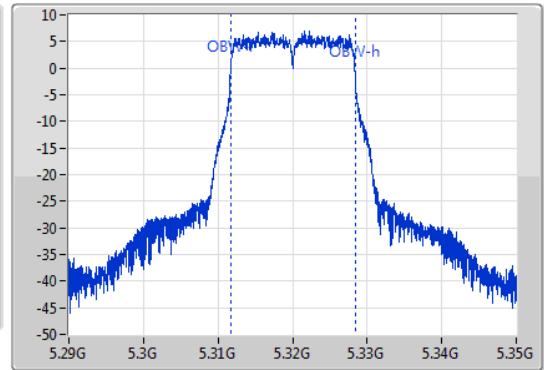

26dB(Hz)	Fl-26dB(Hz)	Fh-26dB(Hz)	OBW(Hz)	Fl-OBW(Hz)	Fh-OBW(Hz)	Limit(Hz)	Port
21.51M	5.30926G	5.33077G	16.762M	5.311664G	5.328426G	Inf	1

802.11a_Nss1,(6Mbps)_1TX

EBW

5500MHz

06/01/2020

CF: 5.5GHz
 Span: 60MHz
 RBW: 300kHz
 VBW: 1MHz
 Sweep Time: 100ms
 Detector Type: Peak
 Port 1

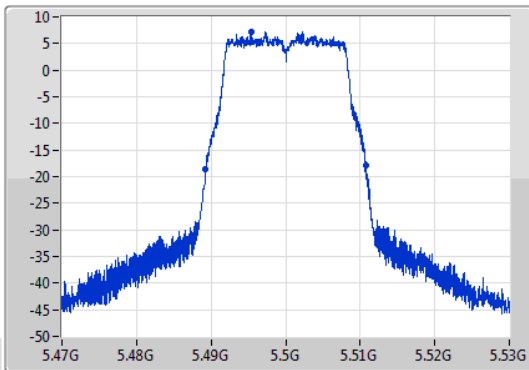

CF: 5.5GHz
 Span: 60MHz
 RBW: 200kHz
 VBW: 1MHz
 Sweep Time: 100ms
 Detector Type: Peak

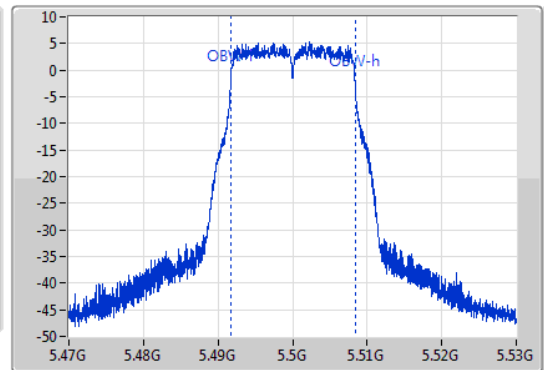

26dB(Hz)	Fl-26dB(Hz)	Fh-26dB(Hz)	OBW(Hz)	Fl-OBW(Hz)	Fh-OBW(Hz)	Limit(Hz)	Port
21.51M	5.48926G	5.51077G	16.732M	5.491694G	5.508426G	Inf	1

802.11a_Nss1,(6Mbps)_1TX

EBW

5580MHz

06/01/2020

CF: 5.58GHz
 Span: 60MHz
 RBW: 300kHz
 VBW: 1MHz
 Sweep Time: 100ms
 Detector Type: Peak
 Port 1

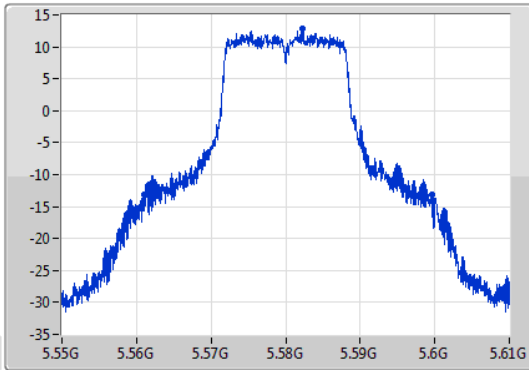

CF: 5.58GHz
 Span: 60MHz
 RBW: 200kHz
 VBW: 1MHz
 Sweep Time: 100ms
 Detector Type: Peak

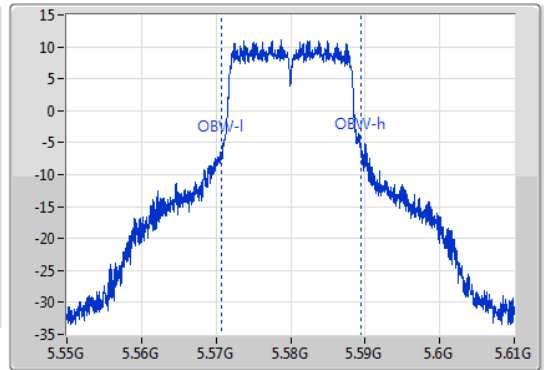

26dB(Hz)	Fl-26dB(Hz)	Fh-26dB(Hz)	OBW(Hz)	Fl-OBW(Hz)	Fh-OBW(Hz)	Limit(Hz)	Port
38.61M	5.56101G	5.59962G	18.771M	5.570735G	5.589505G	Inf	1

802.11a_Nss1,(6Mbps)_1TX

EBW

5700MHz

06/01/2020

CF: 5.7GHz
 Span: 60MHz
 RBW: 300kHz
 VBW: 1MHz
 Sweep Time: 100ms
 Detector Type: Peak
 Port 1

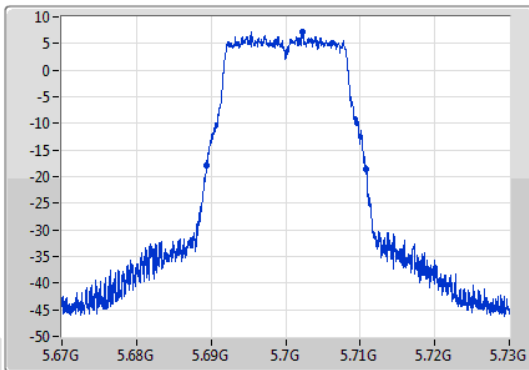

CF: 5.7GHz
 Span: 60MHz
 RBW: 200kHz
 VBW: 1MHz
 Sweep Time: 100ms
 Detector Type: Peak

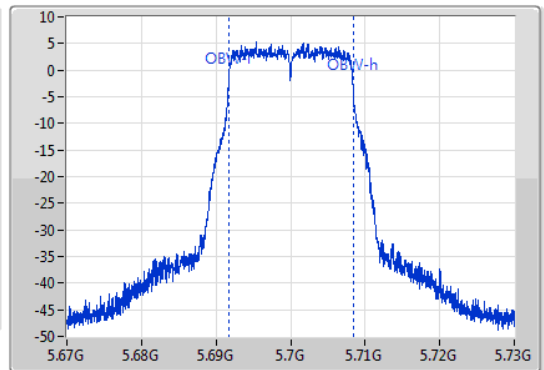

26dB(Hz)	Fl-26dB(Hz)	Fh-26dB(Hz)	OBW(Hz)	Fl-OBW(Hz)	Fh-OBW(Hz)	Limit(Hz)	Port
21.51M	5.68935G	5.71086G	16.762M	5.691664G	5.708426G	Inf	1

802.11a_Nss1,(6Mbps)_1TX

EBW

5720MHz Straddle 5.47-5.725GHz

06/01/2020

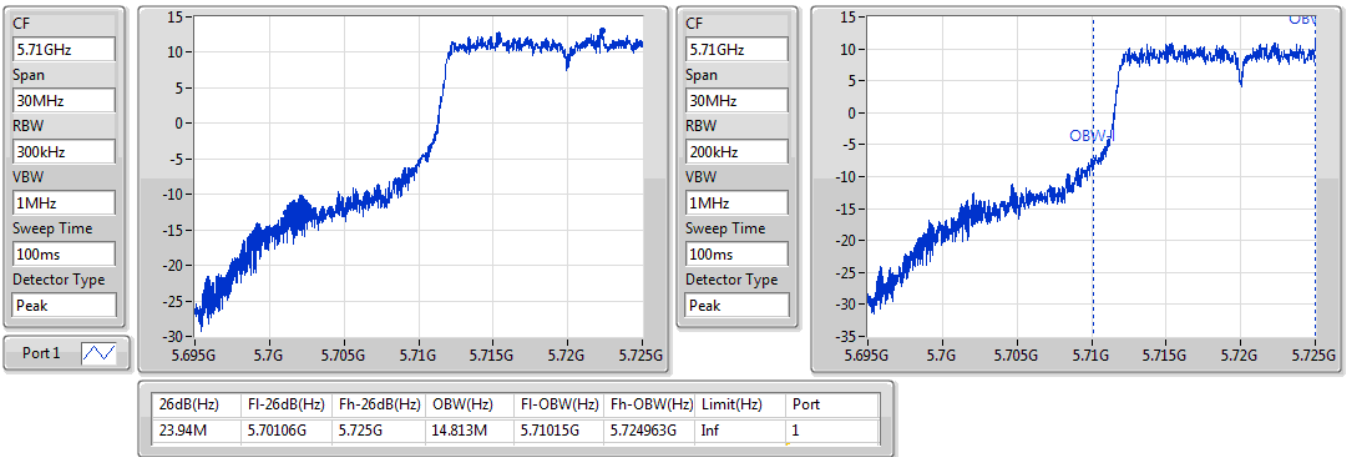

802.11a_Nss1,(6Mbps)_1TX

EBW

5720MHz Straddle 5.725-5.85GHz

06/01/2020

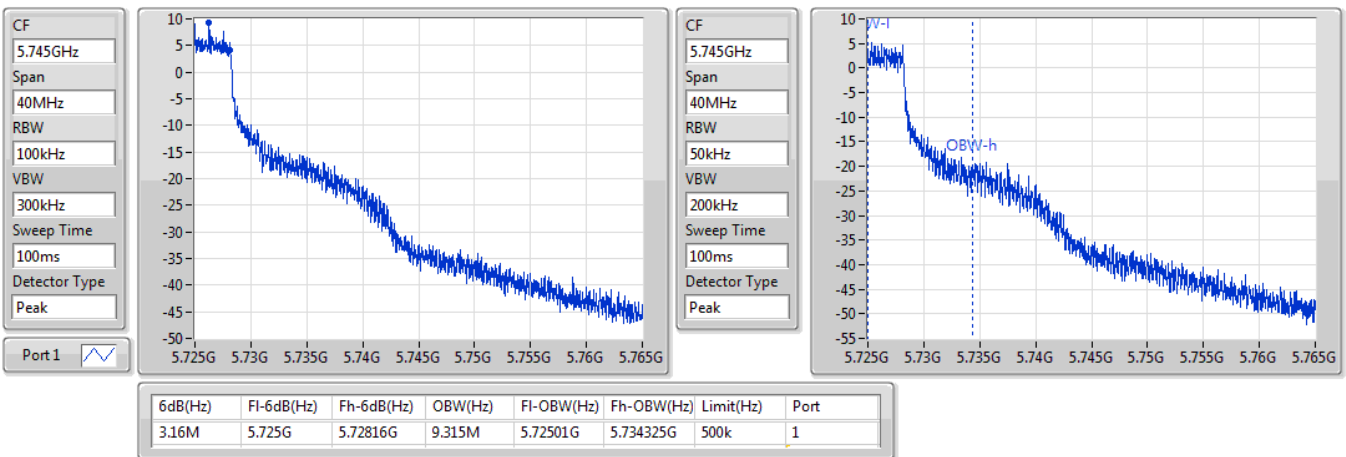

802.11ac VHT20_Nss1,(MCS0)_1TX

EBW

5260MHz

06/01/2020

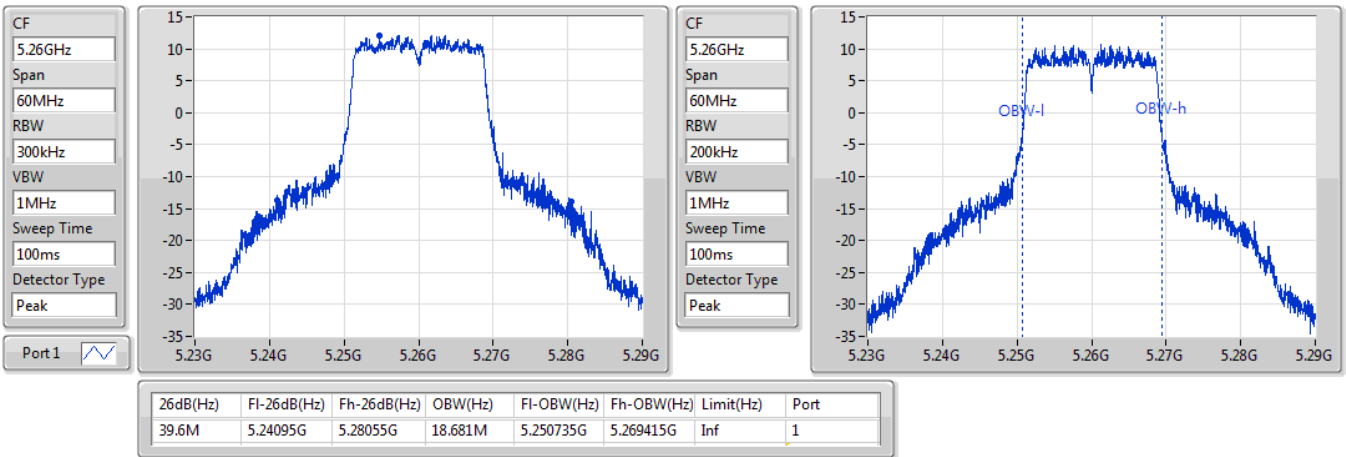

802.11ac VHT20_Nss1,(MCS0)_1TX

EBW

5300MHz

06/01/2020

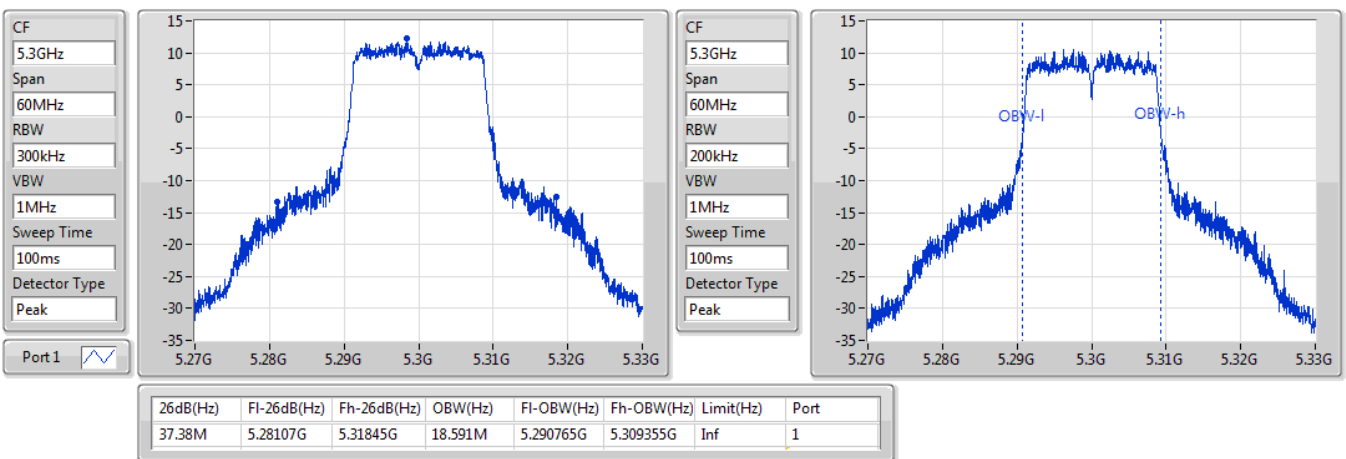

802.11ac VHT20_Nss1,(MCS0)_1TX

EBW

5320MHz

06/01/2020

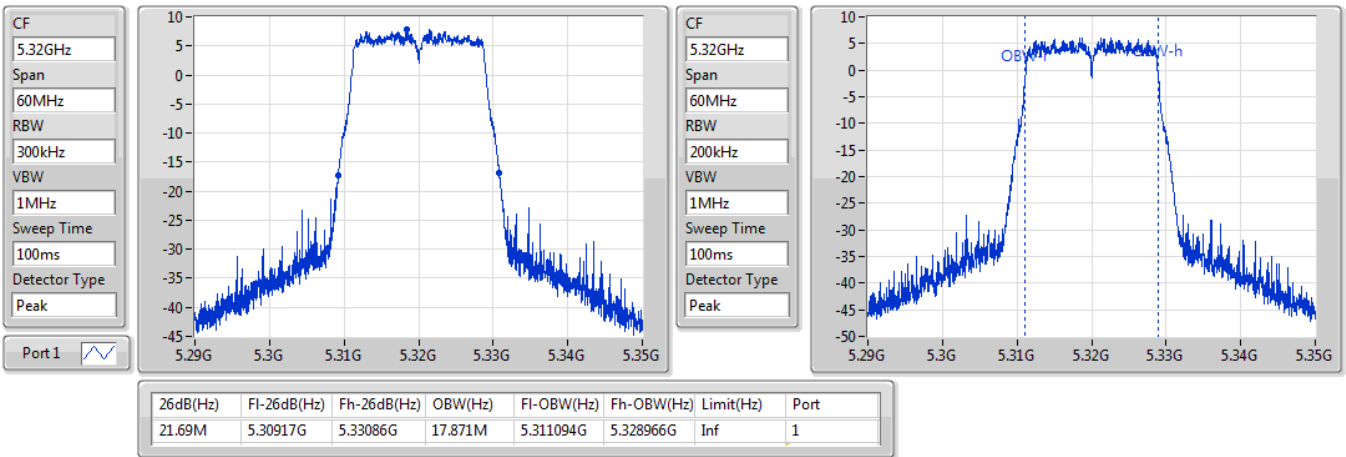

802.11ac VHT20_Nss1,(MCS0)_1TX

EBW

5500MHz

06/01/2020

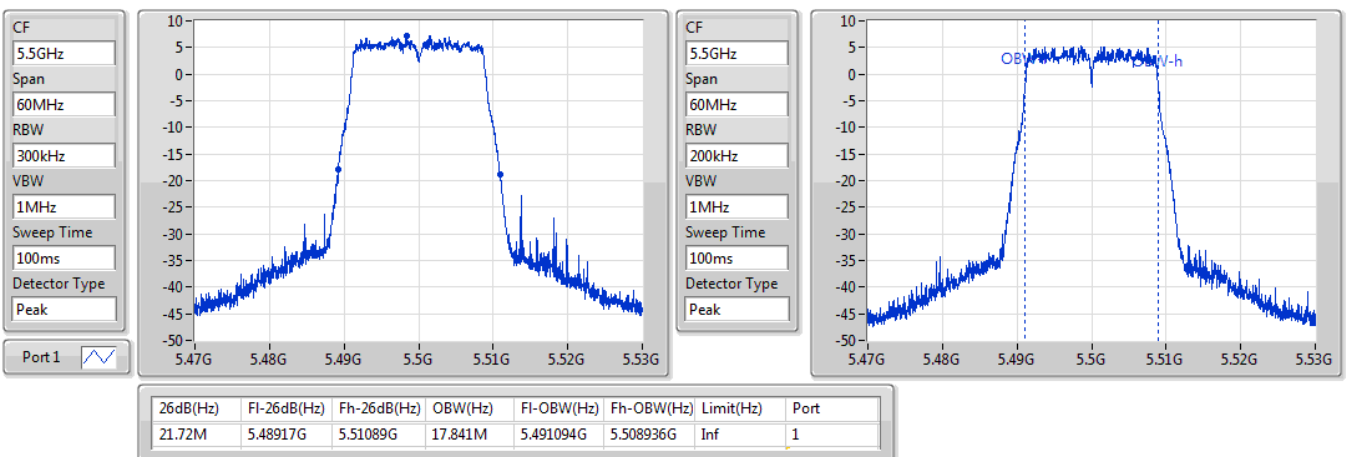

802.11ac VHT20_Nss1,(MCS0)_1TX

EBW

5580MHz

06/01/2020

CF: 5.58GHz
 Span: 60MHz
 RBW: 300kHz
 VBW: 1MHz
 Sweep Time: 100ms
 Detector Type: Peak
 Port 1

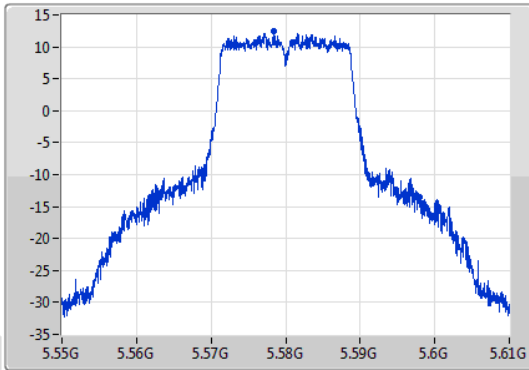

CF: 5.58GHz
 Span: 60MHz
 RBW: 200kHz
 VBW: 1MHz
 Sweep Time: 100ms
 Detector Type: Peak

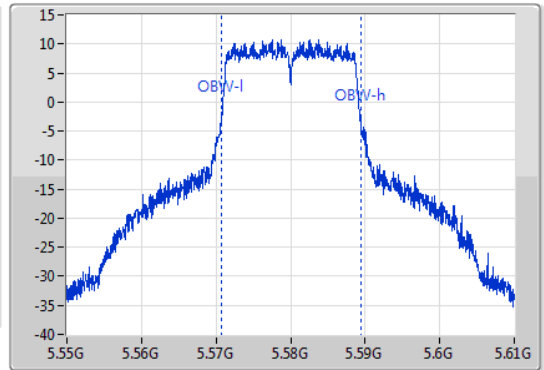

26dB(Hz)	Fl-26dB(Hz)	Fh-26dB(Hz)	OBW(Hz)	Fl-OBW(Hz)	Fh-OBW(Hz)	Limit(Hz)	Port
36.09M	5.56182G	5.59791G	18.651M	5.570735G	5.589385G	Inf	1

802.11ac VHT20_Nss1,(MCS0)_1TX

EBW

5700MHz

06/01/2020

CF: 5.7GHz
 Span: 60MHz
 RBW: 300kHz
 VBW: 1MHz
 Sweep Time: 100ms
 Detector Type: Peak
 Port 1

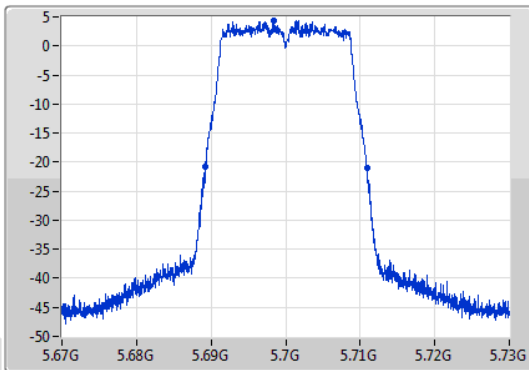

CF: 5.7GHz
 Span: 60MHz
 RBW: 200kHz
 VBW: 1MHz
 Sweep Time: 100ms
 Detector Type: Peak

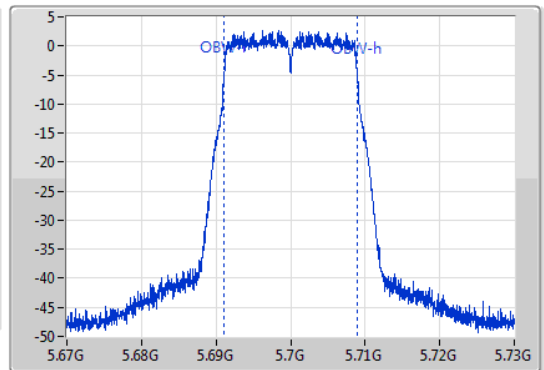

26dB(Hz)	Fl-26dB(Hz)	Fh-26dB(Hz)	OBW(Hz)	Fl-OBW(Hz)	Fh-OBW(Hz)	Limit(Hz)	Port
21.75M	5.68917G	5.71092G	17.841M	5.691094G	5.708936G	Inf	1

802.11ac VHT20_Nss1,(MCS0)_1TX
5720MHz Straddle 5.47-5.725GHz

EBW

06/01/2020

CF: 5.71GHz
 Span: 30MHz
 RBW: 300kHz
 VBW: 1MHz
 Sweep Time: 100ms
 Detector Type: Peak
 Port 1

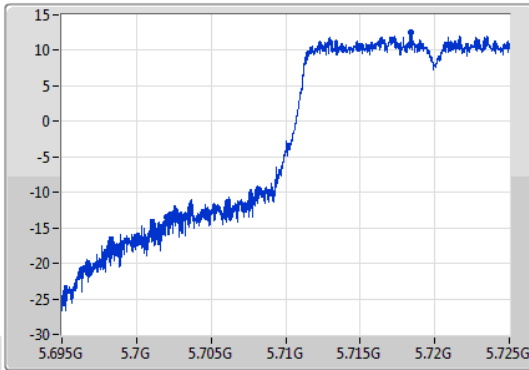

CF: 5.71GHz
 Span: 30MHz
 RBW: 200kHz
 VBW: 1MHz
 Sweep Time: 100ms
 Detector Type: Peak

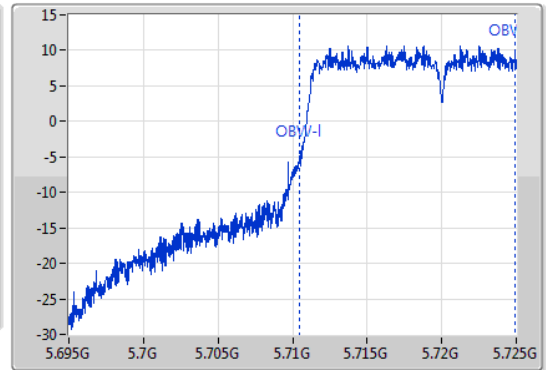

26dB(Hz)	Fl-26dB(Hz)	Fh-26dB(Hz)	OBW(Hz)	Fl-OBW(Hz)	Fh-OBW(Hz)	Limit(Hz)	Port
23.01M	5.70199G	5.725G	14.468M	5.710465G	5.724933G	Inf	1

802.11ac VHT20_Nss1,(MCS0)_1TX
5720MHz Straddle 5.725-5.85GHz

EBW

06/01/2020

CF: 5.745GHz
 Span: 40MHz
 RBW: 100kHz
 VBW: 300kHz
 Sweep Time: 100ms
 Detector Type: Peak
 Port 1

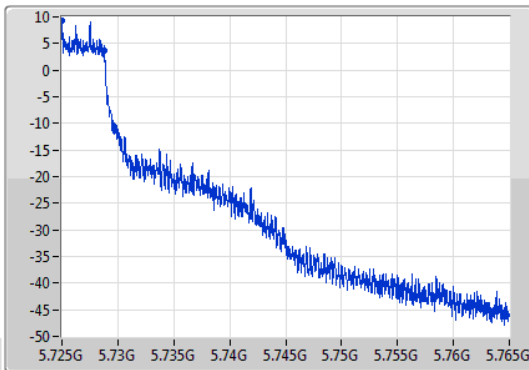

CF: 5.745GHz
 Span: 40MHz
 RBW: 50kHz
 VBW: 200kHz
 Sweep Time: 100ms
 Detector Type: Peak

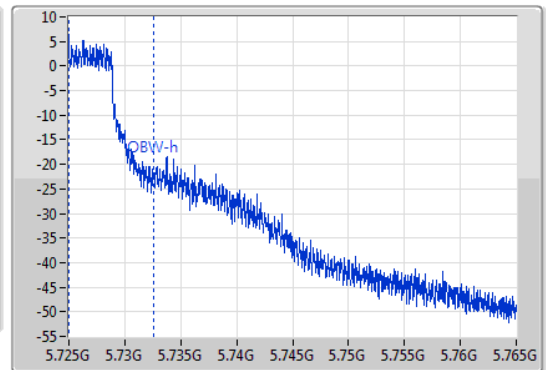

6dB(Hz)	Fl-6dB(Hz)	Fh-6dB(Hz)	OBW(Hz)	Fl-OBW(Hz)	Fh-OBW(Hz)	Limit(Hz)	Port
3.78M	5.725G	5.72878G	7.616M	5.72501G	5.732626G	500k	1

802.11ac VHT40_Nss1,(MCS0)_1TX

EBW

5270MHz

06/01/2020

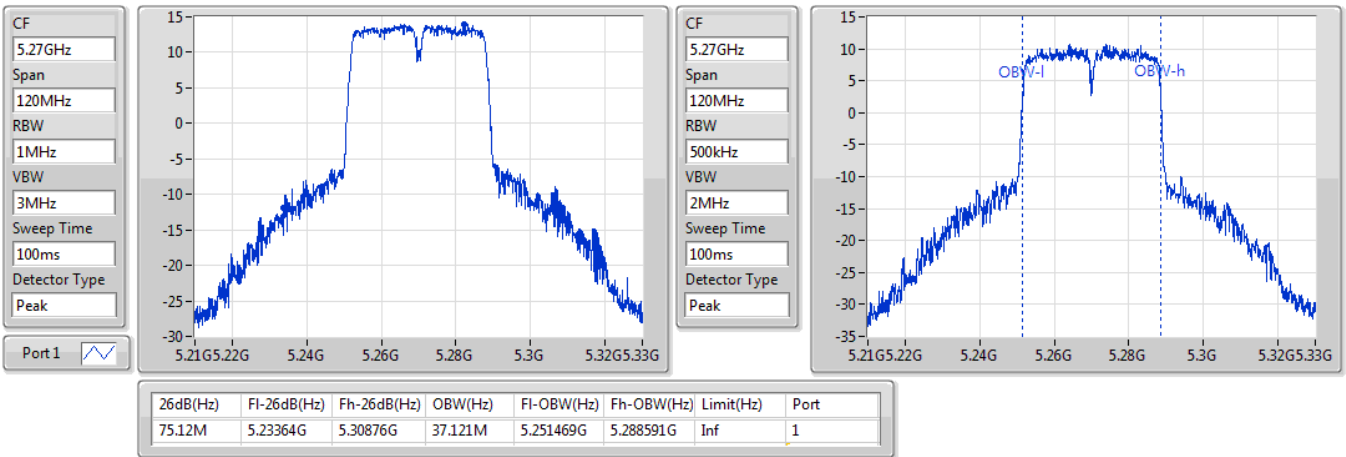

802.11ac VHT40_Nss1,(MCS0)_1TX

EBW

5310MHz

06/01/2020

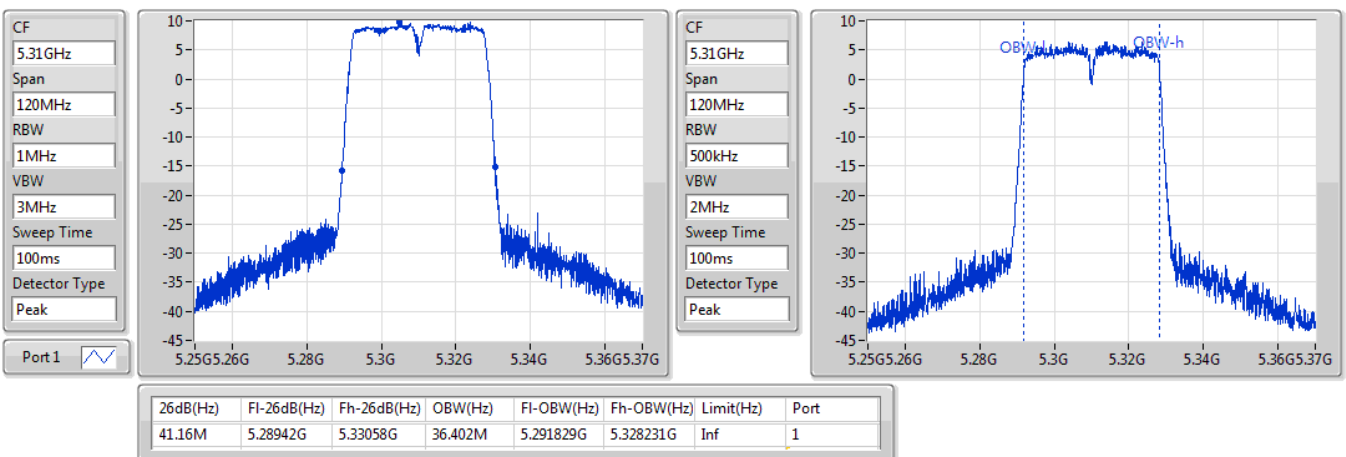

802.11ac VHT40_Nss1,(MCS0)_1TX

EBW

5510MHz

06/01/2020

CF: 5.51GHz
 Span: 120MHz
 RBW: 1MHz
 VBW: 3MHz
 Sweep Time: 100ms
 Detector Type: Peak

Port 1

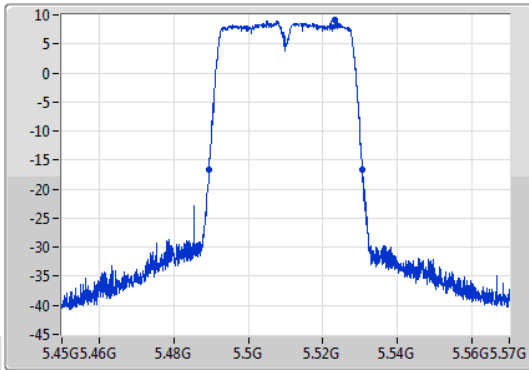

CF: 5.51GHz
 Span: 120MHz
 RBW: 500kHz
 VBW: 2MHz
 Sweep Time: 100ms
 Detector Type: Peak

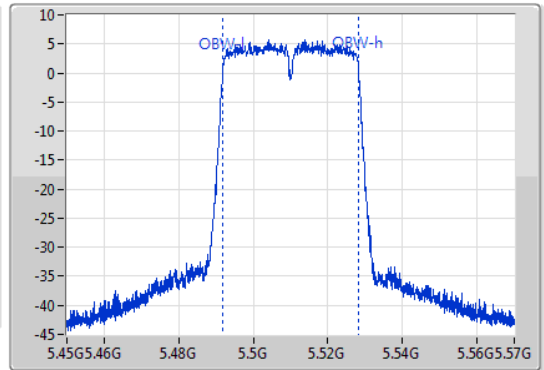

26dB(Hz)	Fl-26dB(Hz)	Fh-26dB(Hz)	OBW(Hz)	Fl-OBW(Hz)	Fh-OBW(Hz)	Limit(Hz)	Port
41.22M	5.48942G	5.53064G	36.402M	5.491829G	5.528231G	Inf	1

802.11ac VHT40_Nss1,(MCS0)_1TX

EBW

5550MHz

06/01/2020

CF: 5.55GHz
 Span: 120MHz
 RBW: 1MHz
 VBW: 3MHz
 Sweep Time: 100ms
 Detector Type: Peak

Port 1

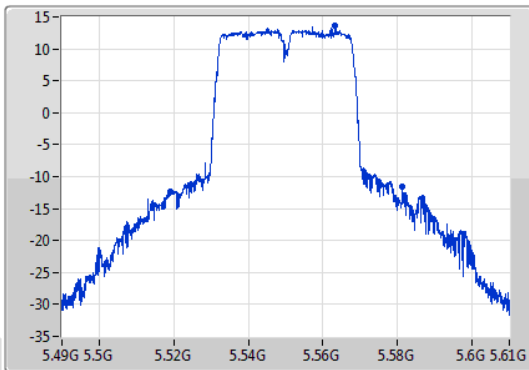

CF: 5.55GHz
 Span: 120MHz
 RBW: 500kHz
 VBW: 2MHz
 Sweep Time: 100ms
 Detector Type: Peak

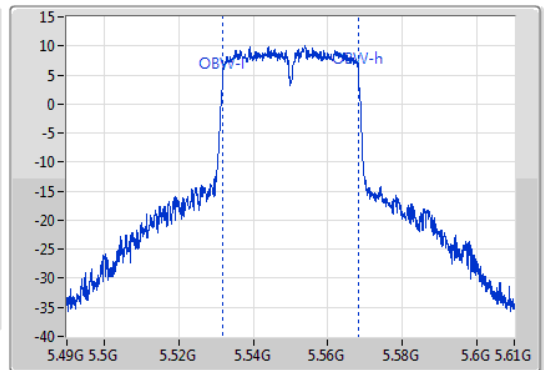

26dB(Hz)	Fl-26dB(Hz)	Fh-26dB(Hz)	OBW(Hz)	Fl-OBW(Hz)	Fh-OBW(Hz)	Limit(Hz)	Port
62.1M	5.51916G	5.58126G	36.702M	5.531649G	5.568351G	Inf	1

802.11ac VHT40_Nss1,(MCS0)_1TX

EBW

5670MHz

06/01/2020

CF
5.67GHz
Span
120MHz
RBW
1MHz
VBW
3MHz
Sweep Time
100ms
Detector Type
Peak

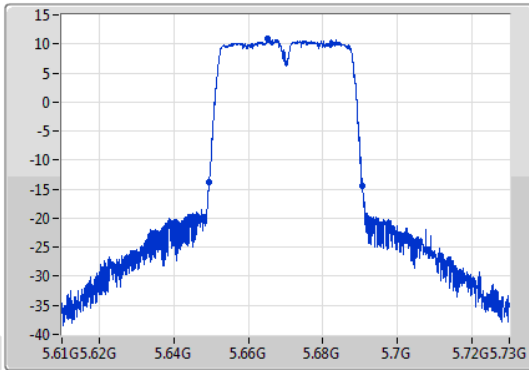

CF
5.67GHz
Span
120MHz
RBW
500kHz
VBW
2MHz
Sweep Time
100ms
Detector Type
Peak

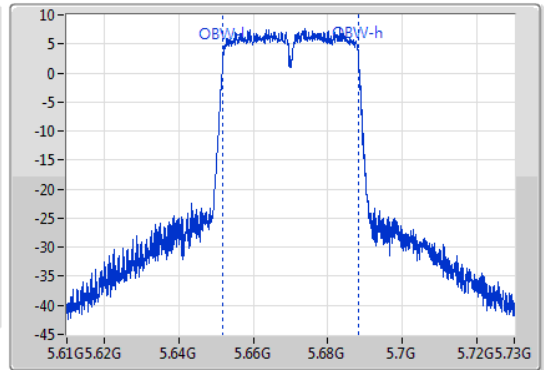

26dB(Hz)	Fl-26dB(Hz)	Fh-26dB(Hz)	OBW(Hz)	Fl-OBW(Hz)	Fh-OBW(Hz)	Limit(Hz)	Port
41.34M	5.6493G	5.69064G	36.402M	5.651829G	5.688231G	Inf	1

802.11ac VHT40_Nss1,(MCS0)_1TX

EBW

5710MHz Straddle 5.47-5.725GHz

06/01/2020

CF
5.69GHz
Span
70MHz
RBW
1MHz
VBW
3MHz
Sweep Time
100ms
Detector Type
Peak

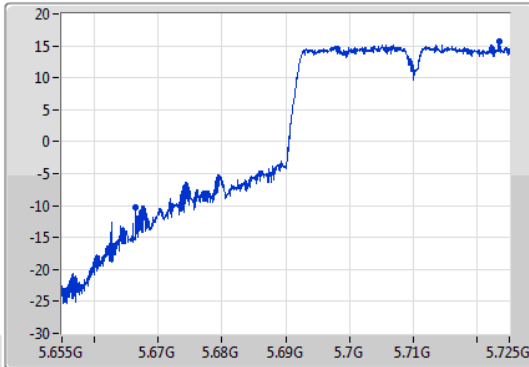

CF
5.69GHz
Span
70MHz
RBW
300kHz
VBW
1MHz
Sweep Time
100ms
Detector Type
Peak

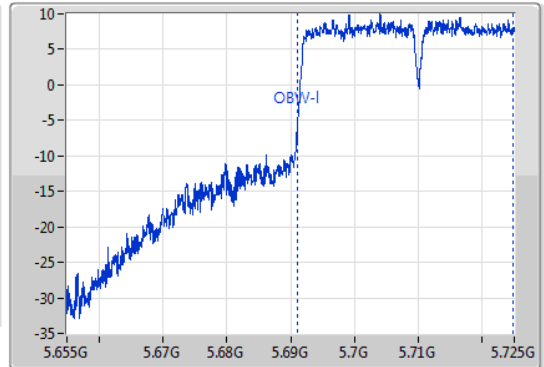

26dB(Hz)	Fl-26dB(Hz)	Fh-26dB(Hz)	OBW(Hz)	Fl-OBW(Hz)	Fh-OBW(Hz)	Limit(Hz)	Port
58.555M	5.666445G	5.725G	33.793M	5.691049G	5.724843G	Inf	1

802.11ac VHT40_Nss1,(MCS0)_1TX

EBW

5710MHz Straddle 5.725-5.85GHz

06/01/2020

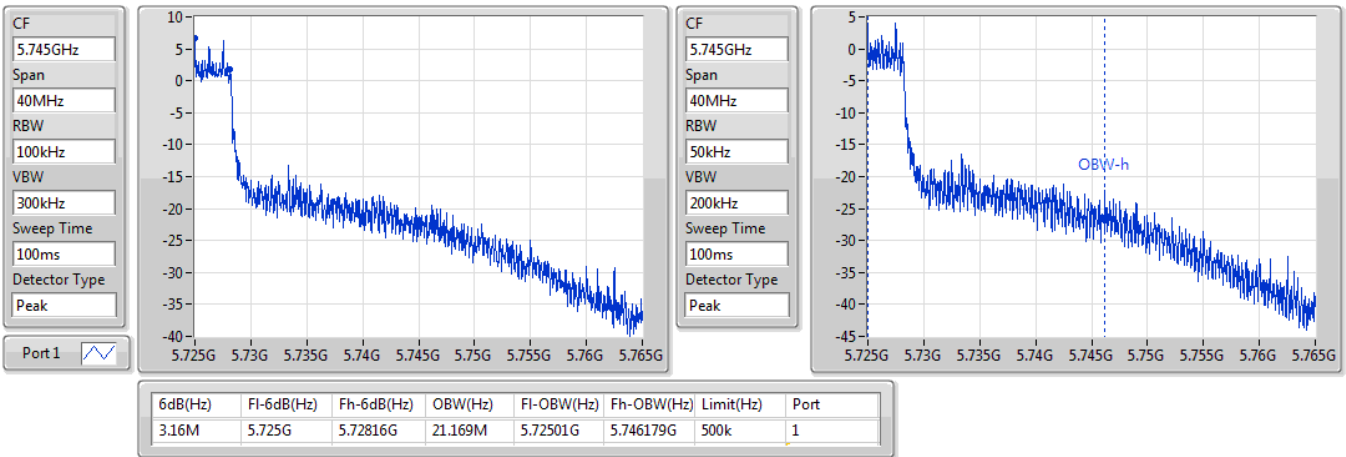

802.11ac VHT80_Nss1,(MCS0)_1TX

EBW

5290MHz

06/01/2020

