

TEST REPORT

Test Report Reference: R71750_B Edition 1

Equipment under Test / model name: CK II (Motorola KRZR K1)

FCC ID: QWY-CKII-KRZR

IC: 6588A-CK2KRZR

Serial Number: 000010

Applicant: Peiker acoustic GmbH & Co. KG

Manufacturer: Peiker acoustic GmbH & Co. KG

Test Laboratory
(CAB)
accredited by
DATech in der TGA GmbH
in compliance with DIN EN ISO/IEC 17025
under the
Reg. No. DAT-P-105/99-21,
FCC Test site registration number 90877
and
Industry Canada Test site registration IC3469 and
FCC Test site registration number 90877

TEST REPORT REFERENCE: R71750_B Edition 1

Contents:	Page
1 IDENTIFICATION	3
1.1 APPLICANT	3
1.2 MANUFACTURER	3
1.3 DATES	3
1.4 TEST LABORATORY	4
1.5 RESERVATION	4
1.6 NORMATIVE REFERENCES	4
1.7 TEST RESULTS	4
2 TECHNICAL DATA OF EQUIPMENT	5
2.1 PERIPHERY DEVICES	5
3 OPERATIONAL STATES AND PHYSICAL BOUNDARIES	6
4 LIST OF MEASUREMENTS	7
5 TEST RESULTS	8
5.1 20 dB BANDWIDTH	8
5.1.1 METHOD OF MEASUREMENT (20 dB BANDWIDTH).....	8
5.1.2 TEST RESULTS (20 dB BANDWIDTH).....	9
5.2 CARRIER FREQUENCY SEPARATION.....	11
5.2.1 METHOD OF MEASUREMENT (CARRIER FREQUENCY SEPARATION)	11
5.2.2 TEST RESULTS (CARRIER FREQUENCY SEPARATION)	12
5.3 NUMBER OF HOPPING FREQUENCIES	14
5.3.1 METHOD OF MEASUREMENT (NUMBER OF HOPPING FREQUENCIES).....	14
5.3.2 TEST RESULTS (NUMBER OF HOPPING FREQUENCIES).....	15
5.4 DWELL TIME.....	16
5.4.1 METHOD OF MEASUREMENT (DWELL TIME).....	16
5.4.2 TEST RESULTS (DWELL TIME).....	17
5.5 MAXIMUM PEAK OUTPUT POWER.....	20
5.5.1 METHOD OF MEASUREMENT (MAXIMUM PEAK OUTPUT POWER).....	20
5.5.2 TEST RESULTS (MAXIMUM PEAK OUTPUT POWER)	21
5.6 BAND-EDGE COMPLIANCE.....	23
5.6.1 METHOD OF MEASUREMENT (BAND-EDGE COMPLIANCE (RADIATED))	23
5.6.2 TEST RESULT (BAND-EDGE COMPLIANCE (RADIATED)).....	24
5.7 RADIATED EMISSIONS.....	28
5.7.1 METHOD OF MEASUREMENT (RADIATED EMISSIONS)	28
5.7.2 TEST RESULTS (RADIATED EMISSIONS).....	35
5.7.2.1 PRELIMINARY MEASUREMENT (9 kHz to 25 GHz).....	35
5.7.2.2 FINAL MEASUREMENT (1 GHz to 25 GHz)	44
6 TEST EQUIPMENT AND ANCILLARIES USED FOR TESTS.....	47
7 LIST OF ANNEXES	49

TEST REPORT REFERENCE: R71750_B Edition 1

1 IDENTIFICATION

1.1 APPLICANT

Name:	PEIKER acustic GmbH & Co. KG
Address:	Max-Plank-Straße 32
	61381 Friedrichsdorf / Ts.
Country:	Germany
Name for contact purposes:	Mr. Karlheinz ERNHARDT
Tel:	+49 6172 767-135
Fax:	+49 6172 72555
e-mail address:	karlheinz.ernhardt@peiker.de

1.2 MANUFACTURER

Name:	PEIKER acustic GmbH & Co. KG
Address:	Max-Plank-Straße 32
	61381 Friedrichsdorf / Ts.
Country:	Germany
Name for contact purposes:	Mr. Karlheinz ERNHARDT
Tel:	+49 6172 767-135
Fax:	+49 6172 72555
e-mail address:	karlheinz.ernhardt@peiker.de

1.3 DATES

Date of receipt of test sample:	11 November 2007
Start of test:	24 January 2008
End of test:	31 January 2008

TEST REPORT REFERENCE: R71750_B Edition 1

2 TECHNICAL DATA OF EQUIPMENT

Type of equipment: *	Bluetooth handsfree unit for vehicular environment					
Type designation / model name: *	CKII (Motorola KRZR K1)					
Hardware / software version: *	3907 / xx07					
FCC ID: *	QWY-CKII-KRZR					
IC: *	6588A-CK2KRZR					
Fulfills Bluetooth specification: *	V2.0, but no EDR					
Antenna type: *	Integral					
Antenna gain: *	0.8 dBi					
Antenna connector: *	None (Integrated Bluetooth-antenna)					
Power supply (bluetooth-unit): *	$U_{nom} =$	12.0 V DC	$U_{min} =$	-	$U_{max} =$	-
Type of modulation: *	FHSS (GFSK)					
Operating frequency range:*	2402 MHz to 2480 MHz					
Number of channels: *	79					
Temperature range: *	-40 °C to +70 °C					

*: declared by the applicant

Bluetooth operates in the unlicensed ISM band at 2.4 GHz. In North America (USA and Canada) a band with a width of 83.5 MHz is available. In this band 79 RF channels spaced 1 MHz apart are defined. The channel is represented by a pseudo random hopping sequence through the 79 channels. The normally occupancy time of one frequency will be 625 μ s. The ordinary hopping rate will be 1600 hops/s. All frequencies will be used equally.

The following external I/O cables were used:

Identification	Connector		Lenght
	EUT	Ancillary	
DC input, audio in/output, control lines	Customised connector	RJ 45 connector	40 cm
-	-	-	-
-	-	-	-

2.1 PERIPHERY DEVICES

The following equipment was used as control unit and ancillary equipment:

- A program adaptor CKII was used to connect the EUT with a power supply.
- A personal computer with a terminal-software was used, connected temporary to the program adaptor CKII, for setting the equipment into the necessary operation mode. During the measurements the personal computer was disconnected.

TEST REPORT REFERENCE: R71750_B Edition 1

3 OPERATIONAL STATES AND PHYSICAL BOUNDARIES

The EUT is intended to be used in a vehicular environment as Bluetooth handsfree unit. All radiated tests were carried out with a sample with integral antenna; conductive tests were carried out with a sample, which was equipped with a temporary antenna connector.

If not otherwise stated, the CKII (Motorola KRZR K1) was powered by an external 13.8 V DC power supply via an program adaptor CKII. The operation mode was adjusted with the help of a test-software and a laptop computer, which was connected to the program adaptor. After adjusting the test mode, the connection between the program adaptor and the laptop computer was terminated.

If not otherwise stated, for modulating the transmitter, a pseudo random bit sequence with a length of 44 byte and with a pattern type DM1 was used.

During the tests, the EUT was not labelled with a FCC-label.

The following operation modes were used during the tests:

Operation mode	Description of the operation mode
1	Continuous transmitting on 2402 MHz
2	Continuous transmitting on 2441 MHz
3	Continuous transmitting on 2480 MHz
4	Transmitter hopping on all channels
5	Continuous receiving on 2441 MHz

Physical boundary of the EUT

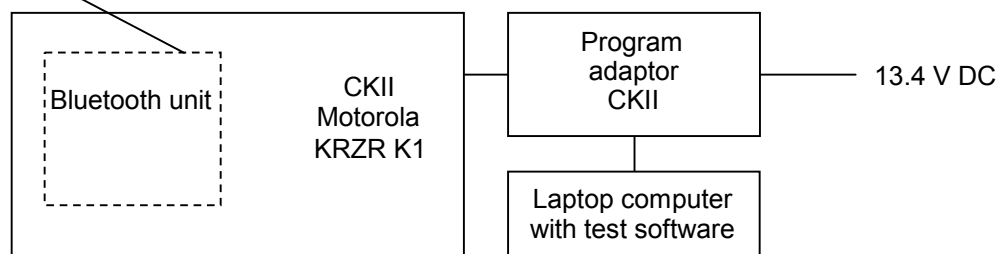

TEST REPORT REFERENCE: R71750_B Edition 1

4 LIST OF MEASUREMENTS

Application	Frequency range [MHz]	FCC 47 CFR Part 15 section [2]	RSS 210, Issue 7 [4] or RSS-Gen, Issue 2 [5]	Status	Refer page
20 dB bandwidth	General	15.247 (a) (1)	A8.1 (b) [4]	Passed	8 et seq.
Carrier frequency separation	General	15.247 (a) (1)	A8.1 (b) [4]	Passed	11 et seq.
Number of hopping channels	2400.0 - 2483.5	15.247 (a) (1) (iii)	A8.1 (d) [4]	Passed	14 et seq.
Dwell time	2400.0 - 2483.5	15.247 (a) (1) (iii)	A8.1 (d) [4]	Passed	16 et seq.
Maximum peak output power	2400.0 - 2483.5	15.247 (b) (1)	A8.4 (2) [4]	Passed	20 et seq.
Band edge compliance	2400.0 - 2483.5	15.247 (d)	A8.5 [4]	Passed	23 et seq.
Radiated emissions (transmitter)	0.009 - 25,000	15.205 (a) 15.209 (a)	A8.5 [4] 2.6 [4]	Passed	28 et seq.
Conducted emissions on supply line	0.15 - 30	15.207 (a)	7.2.2 [5]	Not applicable *	-
Radiated emissions (receiver)	0.009 - 25,000	15.109 (a)	6 [5] 2.6 [4]	Passed	Annex D

*: Not applicable, because the EUT is intended to be used in a vehicular environment.

TEST REPORT REFERENCE: R71750_B Edition 1

5 TEST RESULTS

5.1 20 dB BANDWIDTH

5.1.1 METHOD OF MEASUREMENT (20 dB BANDWIDTH)

The calibration of the spectrum analyser has to be checked with the help of a known signal from a signal generator. The EUT has to be connected to the spectrum analyser via a low loss cable. If the EUT is not equipped with an antenna connector, a temporary antenna connector has to be installed. The EUT has to be switched on and the hopping function has to be disabled, the transmitter shall work with its maximum data rate.

The following spectrum analyser settings shall be used:

- Span: App. 2 to 3 times the 20 dB bandwidth, centred on the actual hopping channel.
- Resolution bandwidth: $\geq 1\%$ of the 20 dB bandwidth.
- Video bandwidth: \geq the resolution bandwidth.
- Sweep: Auto.
- Detector function: peak.
- Trace mode: Max hold.

After trace stabilisation the marker shall be set on the signal peak. The first display line has to be set on this value. The second display line has to be set 20 dB below the first line (or the peak marker). The frequency lines shall be set on the intersection points between the second display line and the measured curve.

The measurement will be performed at the upper, the lower end and the middle of the assigned frequency band.

Test set-up:



TEST REPORT REFERENCE: R71750_B Edition 1

5.1.2 TEST RESULTS (20 dB BANDWIDTH)

Ambient temperature	20 °C	Relative humidity	32 %
---------------------	-------	-------------------	------

71750_45.wmf: (20 dB bandwidth at the lower end of the assigned frequency band):

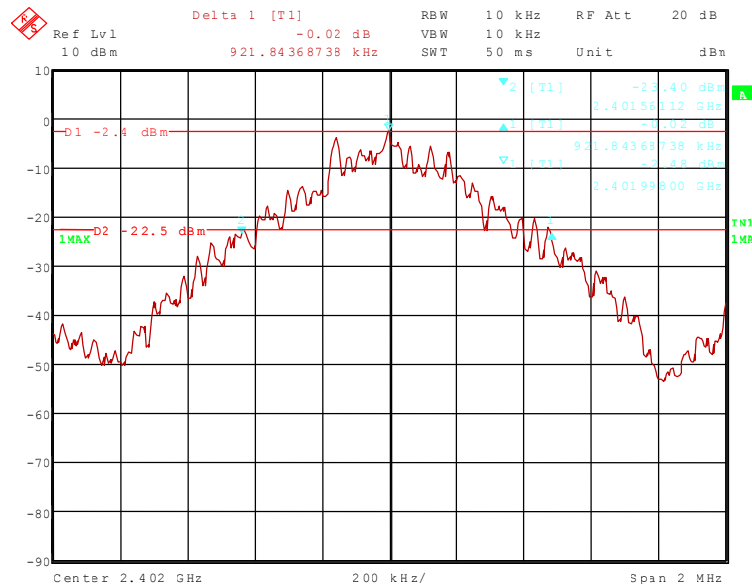

71750_46.wmf: (20 dB bandwidth at the middle of the assigned frequency band):

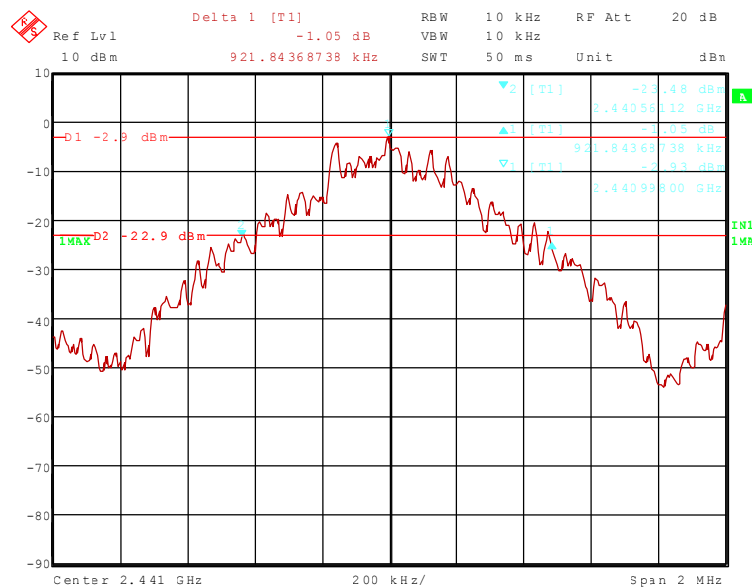

TEST REPORT REFERENCE: R71750_B Edition 1

71750_47.wmf: (20 dB bandwidth at the upper end of the assigned frequency band):

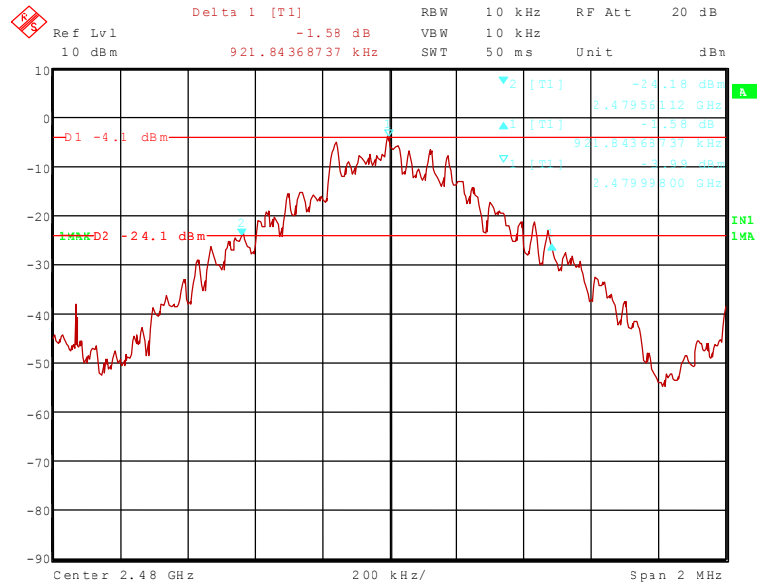

Channel number	Channel frequency [MHz]	20 dB bandwidth [kHz]
0	2402	921.844
39	2441	921.844
78	2480	921.844
Measurement uncertainty		+0.66 dB / -0.72 dB

TEST EQUIPMENT USED FOR THE TEST:

31, 46, 54

TEST REPORT REFERENCE: R71750_B Edition 1

5.2 CARRIER FREQUENCY SEPARATION

5.2.1 METHOD OF MEASUREMENT (CARRIER FREQUENCY SEPARATION)

The calibration of the spectrum analyser has to be checked with the help of a known signal from a signal generator. The EUT has to be connected to the spectrum analyser via a low loss cable. If the EUT is not equipped with an antenna connector, a temporary antenna connector has to be installed. The EUT has to be switched on and the hopping function has to be enabled.

The following spectrum analyser settings shall be used:

- Span: Wide enough to capture the peaks of two adjacent channels.
- Resolution bandwidth: $\geq 1\%$ of the span.
- Video bandwidth: \geq the resolution bandwidth.
- Sweep: Auto.
- Detector function: peak.
- Trace mode: Max hold.

After trace stabilisation the marker and the delta marker function will be used to determine the separation between the peaks of two adjacent channel signals.

The measurement will be performed at the upper, the lower end and the middle of the assigned frequency band.

Test set-up:

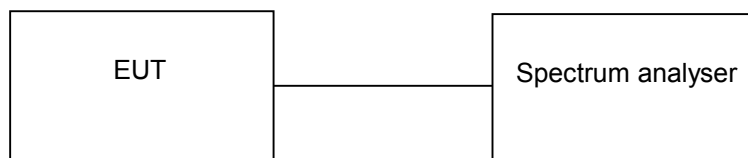

TEST REPORT REFERENCE: R71750_B Edition 1

5.2.2 TEST RESULTS (CARRIER FREQUENCY SEPARATION)

Ambient temperature	20 °C	Relative humidity	32 %
---------------------	-------	-------------------	------

71750_48.wmf: (channel separation at the lower end of the assigned frequency band):

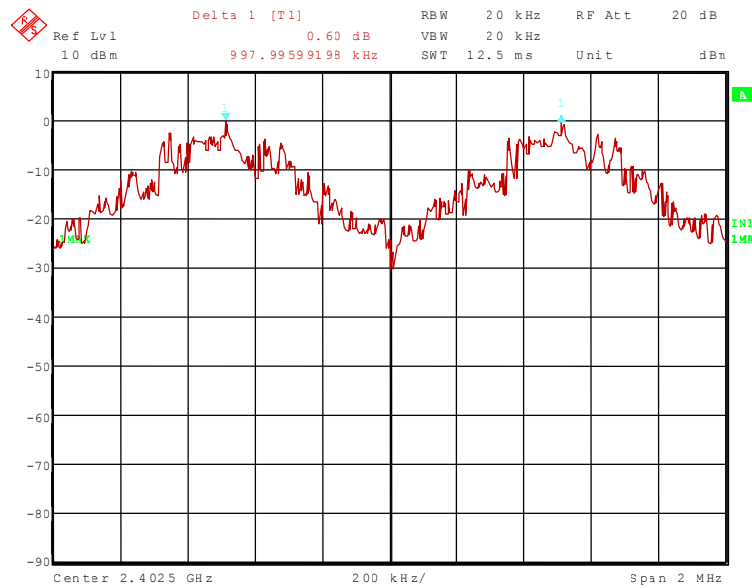

71750_49.wmf: (channel separation at the middle of the assigned frequency band):

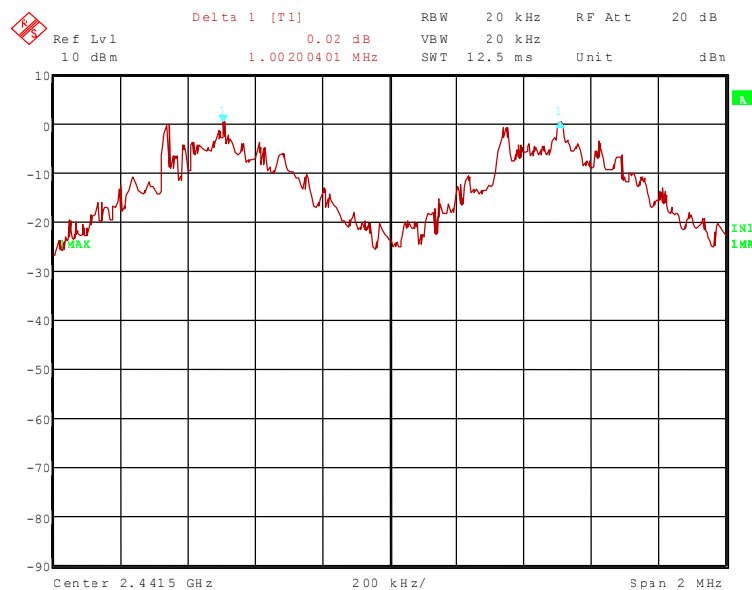

TEST REPORT REFERENCE: R71750_B Edition 1

71750_50.wmf: (channel separation at the upper end of the assigned frequency band):

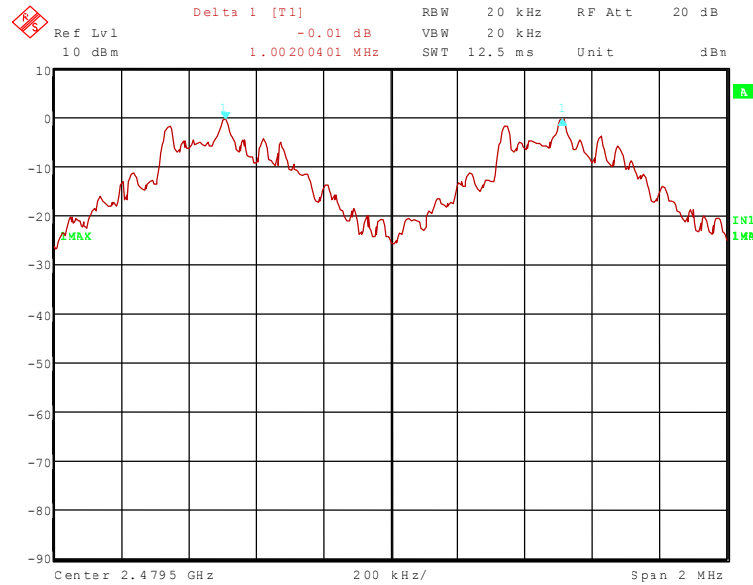

Channel number	Channel frequency [MHz]	Channel separation [kHz]	Minimum limit [kHz]
0	2402	997.996	614.563 (2/3 of the 20 dB bandwidth)
39	2441	1002.004	614.563 (2/3 of the 20 dB bandwidth)
78	2480	1002.004	614.563 (2/3 of the 20 dB bandwidth)
Measurement uncertainty			$<10^{-7}$

Test: Passed

TEST EQUIPMENT USED FOR THE TEST:

31, 46, 54

TEST REPORT REFERENCE: R71750_B Edition 1

5.3 NUMBER OF HOPPING FREQUENCIES

5.3.1 METHOD OF MEASUREMENT (NUMBER OF HOPPING FREQUENCIES)

The calibration of the spectrum analyser has to be checked with the help of a known signal from a signal generator. The EUT has to be connected to the spectrum analyser via a low loss cable. If the EUT is not equipped with an antenna connector, a temporary antenna connector has to be installed. The EUT has to be switched on and the hopping function has to be enabled.

The following spectrum analyser settings shall be used:

- Span: Equal to the assigned frequency band.
- Resolution bandwidth: $\geq 1\%$ of the span.
- Video bandwidth: \geq the resolution bandwidth.
- Sweep: Auto.
- Detector function: Peak.
- Trace mode: Max hold.

After trace stabilisation the number of hopping channels could be counted. It might be possible to divide the span into some sub ranges in order to clearly show all hopping frequencies.

Test set-up:

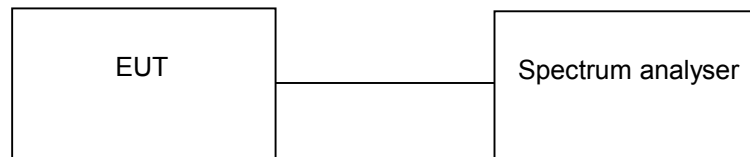

TEST REPORT REFERENCE: R71750_B Edition 1

5.3.2 TEST RESULTS (NUMBER OF HOPPING FREQUENCIES)

Ambient temperature	20 °C	Relative humidity	32 %
---------------------	-------	-------------------	------

71750_51.wmf (number of hopping channels):

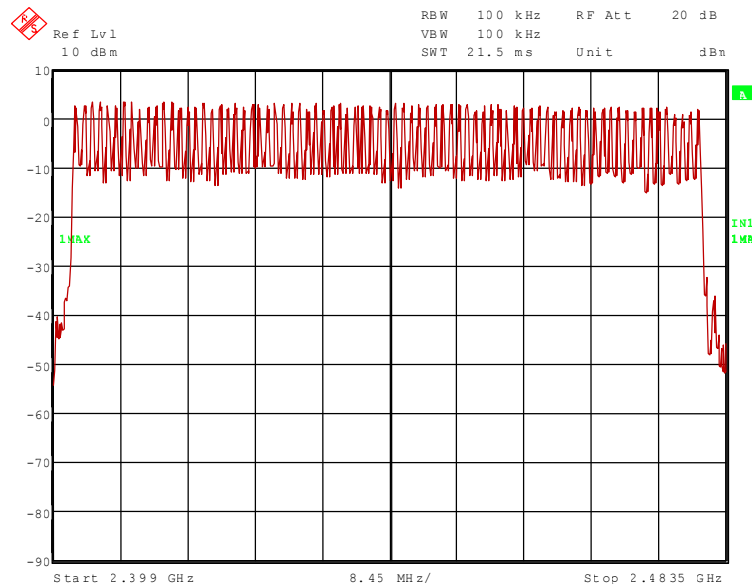

Number of hopping channels	Limit
79	At least 15

Test: Passed

TEST EQUIPMENT USED FOR THE TEST:

31, 46, 54

TEST REPORT REFERENCE: R71750_B Edition 1

5.4 DWELL TIME

5.4.1 METHOD OF MEASUREMENT (DWELL TIME)

The calibration of the spectrum analyser has to be checked with the help of a known signal from a signal generator. The EUT has to be connected to the spectrum analyser via a low loss cable. If the EUT is not equipped with an antenna connector, a temporary antenna connector has to be installed. The EUT has to be switched on and the hopping function has to be enabled.

The following spectrum analyser settings shall be used:

- Span: Zero, centred on a hopping channel.
- Resolution bandwidth: 1 MHz.
- Video bandwidth: \geq the resolution bandwidth.
- Sweep: As necessary to capture the entire dwell time per hopping channel.
- Detector function: peak.
- Trace mode: Max hold.

The marker and delta marker function of the spectrum analyser will be used to determine the dwell time.

The measurement will be performed at the upper and lower end and the middle of the assigned frequency band.

If the EUT is possible to operate with different mode of operation (data rates, modulation formats etc.) the test will be repeated with every different operation mode of the EUT.

Test set-up:

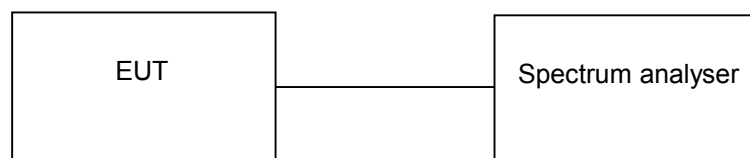

TEST REPORT REFERENCE: R71750_B Edition 1

5.4.2 TEST RESULTS (DWELL TIME)

Ambient temperature	20 °C	Relative humidity	32 %
---------------------	-------	-------------------	------

71750_55.wmf: Dwell time at the middle of the assigned frequency band), hopping mode HV1:

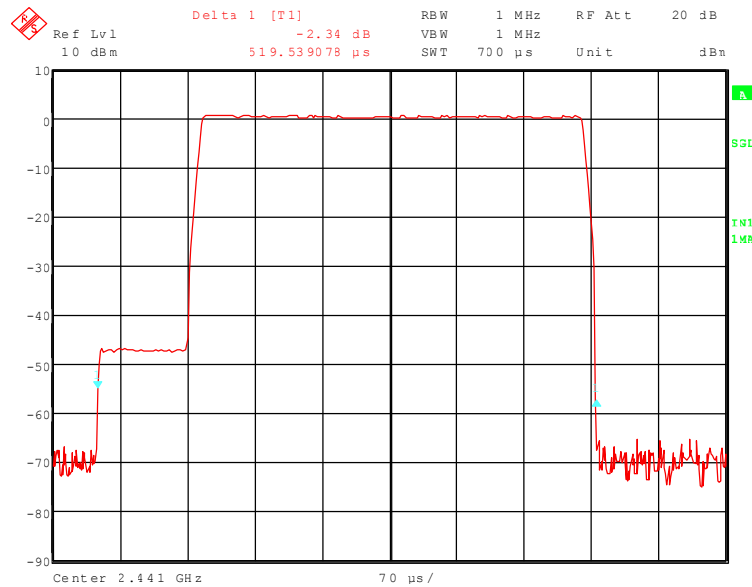

71750_56.wmf: Dwell time at the middle of the assigned frequency band), hopping mode DH3:

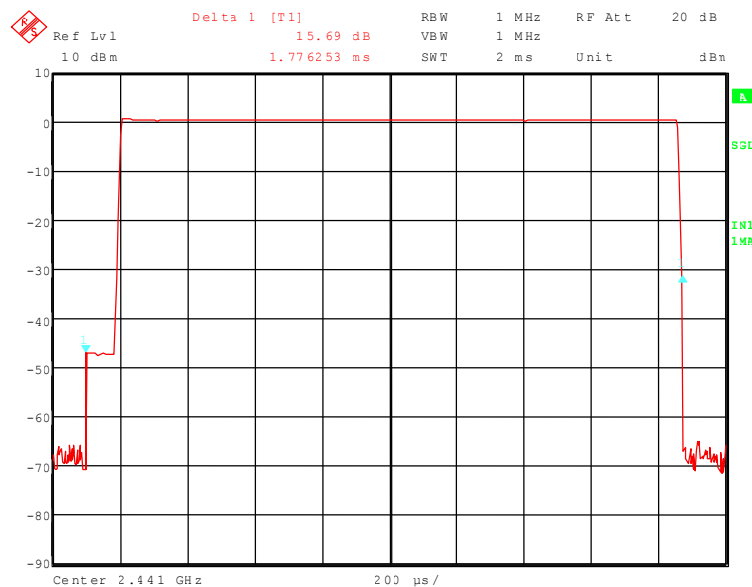

TEST REPORT REFERENCE: R71750_B Edition 1

71750_57.wmf: Dwell time at the middle of the assigned frequency band), hopping mode DH5:

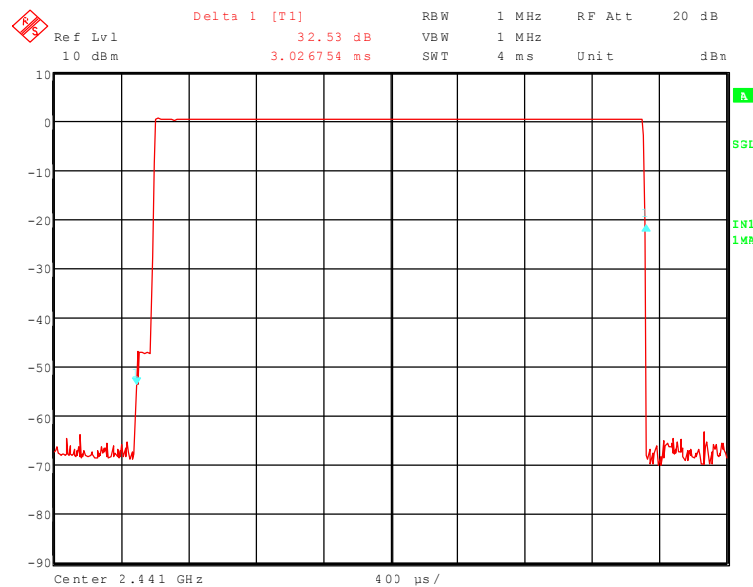

The dwell time is calculated with the following formula:

Dwell time = $t_{\text{pulse}} \times n_{\text{hops}} / \text{number of hopping channels} \times 31.6$ (equal to 0.4 s x number of hopping channels)

Where:

t_{pulse} is the measured pulse time (pls. refer the plots of the spectrum analyser above) [s],

n_{hops} is the number of hops per second in the actual operating mode of the transmitter [1/s].

The hopping rate of the system is 1600 hops per second and the system uses 79 channels. For this reason one time slot has a length of 625 μs .

With the used hopping mode (HV1) a packet need 1 timeslot for transmitting and the next timeslot for receiving. So the system makes in worst case 800 hops per second in transmit mode ($n_{\text{hops}} = 800$ 1/s).

With the used hopping mode (DH3) a packet need 3 timeslots for transmitting and the next timeslot for receiving. So the system makes in worst case 400 hops per second in transmit mode ($n_{\text{hops}} = 400$ 1/s).

With the used hopping mode (DH5) a packet need 5 timeslots for transmitting and the next timeslot for receiving. So the system makes in worst case 266.667 hops per second in transmit mode ($n_{\text{hops}} = 266.667$ 1/s).

TEST REPORT REFERENCE: R71750_B Edition 1

Hopping mode HV1				
Channel number	Channel frequency [MHz]	t_{pulse} [μs]	Dwell time [ms]	Limit [ms]
39	2441	519.539	166.252	400
Hopping mode DH3				
Channel number	Channel frequency [MHz]	t_{pulse} [ms]	Dwell time [ms]	Limit [ms]
39	2441	1.776	284.160	400
Hopping mode DH5				
Channel number	Channel frequency [MHz]	t_{pulse} [ms]	Dwell time [ms]	Limit [ms]
39	2441	3.027	322.880	400
Measurement uncertainty			$<10^{-7}$	

Test: Passed

TEST EQUIPMENT USED FOR THE TEST:

31, 46, 54

TEST REPORT REFERENCE: R71750_B Edition 1

5.5 MAXIMUM PEAK OUTPUT POWER

5.5.1 METHOD OF MEASUREMENT (MAXIMUM PEAK OUTPUT POWER)

The calibration of the spectrum analyser has to be checked with the help of a known signal from a signal generator. The EUT has to be connected to the spectrum analyser via a low loss cable. If the EUT is not equipped with an antenna connector, a temporary antenna connector has to be installed. The EUT has to be switched on and the hopping function has to be disabled.

The following spectrum analyser settings shall be used:

- Span: Approx. 5 times the 20 dB bandwidth, centred on a hopping channel.
- Resolution bandwidth: > the 20 dB bandwidth of the emission being measured.
- Video bandwidth: \geq the resolution bandwidth.
- Sweep: Auto.
- Detector function: peak.
- Trace mode: Max hold.

After trace stabilisation the marker shall be set on the signal peak. The indicated level is the peak output power, which has to be corrected with the value of the cable loss and an external attenuation (if necessary).

The measurement will be performed at the upper and lower end and the middle of the assigned frequency band.

Test set-up:

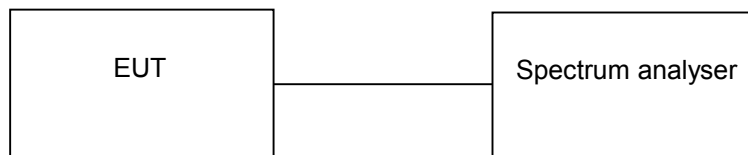

TEST REPORT REFERENCE: R71750_B Edition 1

5.5.2 TEST RESULTS (MAXIMUM PEAK OUTPUT POWER)

Ambient temperature	20 °C	Relative humidity	32 %
---------------------	-------	-------------------	------

71750_52.wmf (maximum peak output power at the lower end of the assigned frequency band):

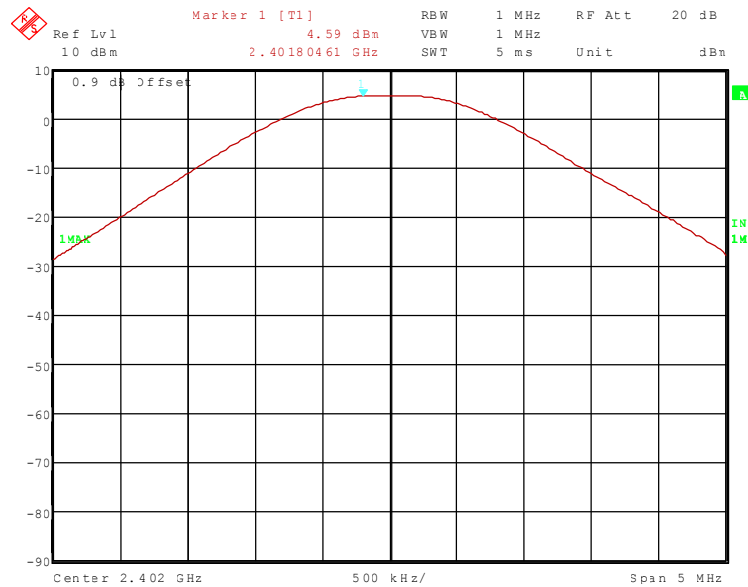

71750_53.wmf (maximum peak output power at the middle of the assigned frequency band):

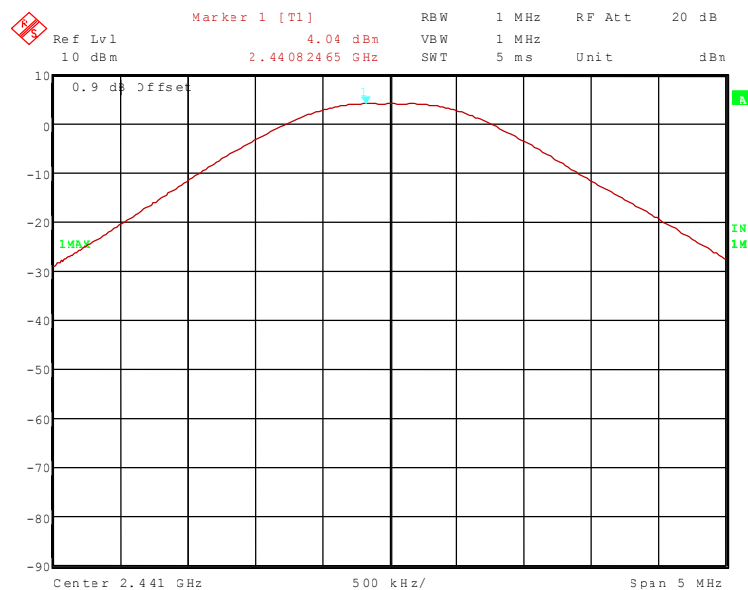

TEST REPORT REFERENCE: R71750_B Edition 1

71750_54.wmf (maximum peak output power at the upper end of the assigned frequency band):

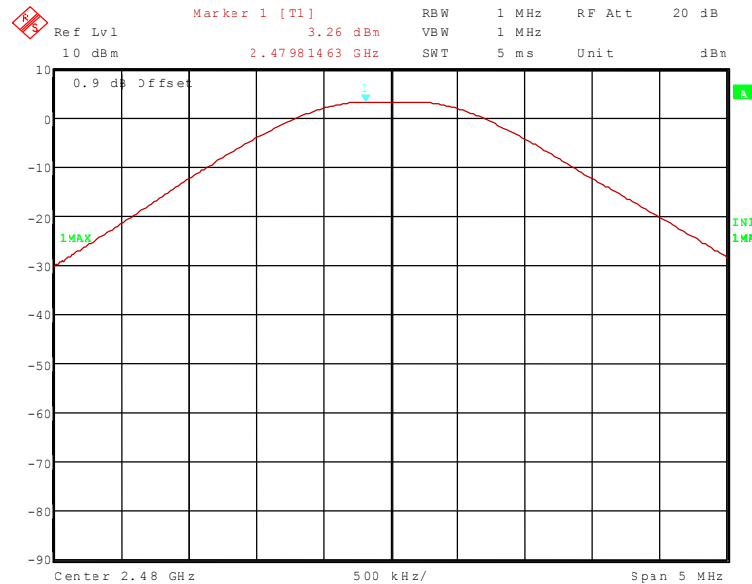

Channel number	Channel frequency [MHz]	Maximum peak output power [dBm]	Antenna gain [dBi]	Peak power limit [dBm]
0	2402	4.6	0.8	30.0
39	2441	4.0	0.8	30.0
78	2480	3.3	0.8	30.0
Measurement uncertainty				+0.66 dB / -0.72 dB

Test: Passed

TEST EQUIPMENT USED FOR THE TEST:

31, 46, 54

TEST REPORT REFERENCE: R71750_B Edition 1

5.6 BAND-EDGE COMPLIANCE

5.6.1 METHOD OF MEASUREMENT (BAND-EDGE COMPLIANCE (RADIATED))

The same test set-up as used for the final radiated emission measurement shall be used (refer also subclause 5.8.1 of this test report). The measurements shall be carried out with using a resolution bandwidth of 100 kHz.

The following spectrum analyser settings shall be used:

- Span: Wide enough to capture the peak level of the emission on the channel closest to the band-edge, as well as any modulation products, which fall outside the assigned frequency band.
- Resolution bandwidth: 100 kHz.
- Video bandwidth: \geq the resolution bandwidth.
- Sweep: Auto.
- Detector function: Peak.
- Trace mode: Max hold.

After trace stabilisation the marker shall be set on the signal peak. The first display line has to be set on this value. The second display line has to be set 20 dB below the first line (or the peak marker). The frequency line shall be set on the edge of the assigned frequency band. Set the second marker on the emission at the band-edge, or on the highest modulation product outside of the band, if this level is higher than that at the band-edge. This frequency shall be measured with the EMI receiver as described in subclause 5.8.1 of this test report, but 100 kHz resolution bandwidth shall be used.

The measurement will be performed at the upper end of the assigned frequency band and with hopping on and off.

TEST REPORT REFERENCE: R71750_B Edition 1

5.6.2 TEST RESULT (BAND-EDGE COMPLIANCE (RADIATED))

Ambient temperature	20 °C	Relative humidity	45 %
---------------------	-------	-------------------	------

71750_15.wmf (radiated band-edge compliance, lower band edge, hopping off):

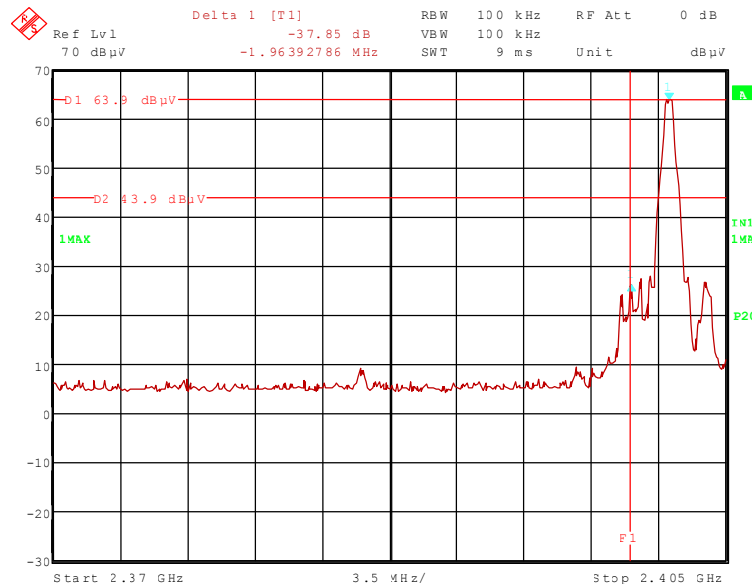

71750_16.wmf (radiated band-edge compliance, lower band edge, hopping on):

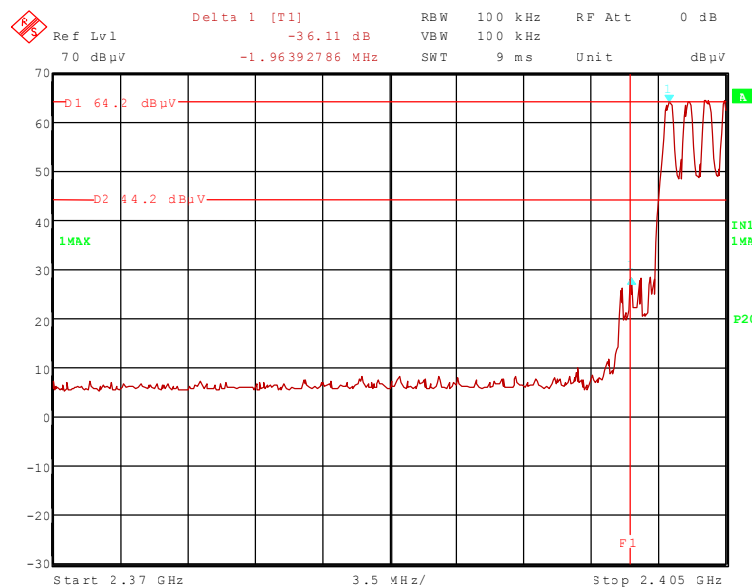

TEST REPORT REFERENCE: R71750_B Edition 1

71750_18.wmf (radiated band-edge compliance, upper band edge, hopping off):

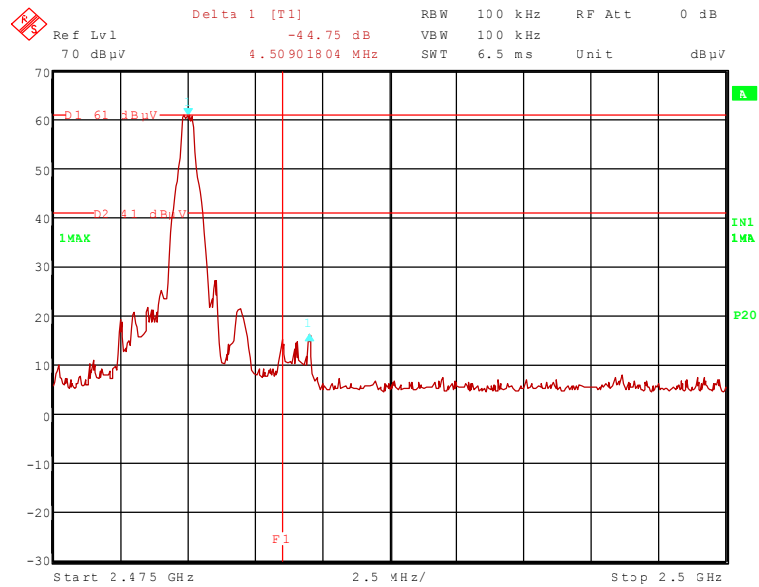

71750_17.wmf (radiated band-edge compliance, upper band edge, hopping on):

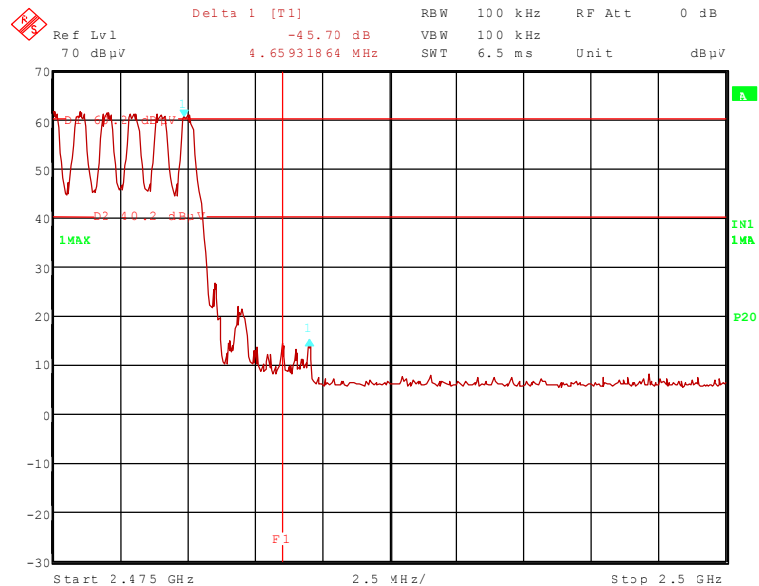

TEST REPORT REFERENCE: R71750_B Edition 1

The plots on the page before are showing the radiated band-edge compliance for the upper band-edge, with and without hopping. The display line 1 (D1) in these plots represents the highest level within the assigned frequency band. The display line 2 (D2) represents the 20 dB offset to this highest level and shows the compliance with FCC 47 CFR Part 15.247 (d). The frequency line 1 (F1) shows the edge of the assigned frequency.

Band-edge compliance (lower band edge, hopping disabled)										
Result measured with the peak detector:										
Frequency GHz	Corr. value dB μ V/m	Limit dB μ V/m	Margin dB	Readings dB μ V	Antenna factor 1/m	Preamp dB	Cable loss dB	Height cm	Pol.	Restr. Band
2.402	94.7	-	-	62.2	28.8	0.0	3.7	150	Hor.	-
2.400	56.8	74.7	17.9	24.3	28.8	0.0	3.7	150	Hor.	No
Result measured with the average detector:										
Frequency GHz	Corr. value dB μ V/m	Limit dB μ V/m	Margin dB	Readings dB μ V	Antenna factor 1/m	Preamp dB	Cable loss dB	Height cm	Pol.	Restr. Band
2.402	84.3	-	-	51.8	28.8	0.0	3.7	150	Hor.	-
2.400	46.4	64.3	17.9	13.9	28.8	0.0	3.7	150	Hor.	No
Measurement uncertainty							+2.2 dB / -3.6 dB			

Band-edge compliance (lower band edge, hopping enabled)										
Result measured with the peak detector:										
Frequency GHz	Corr. value dB μ V/m	Limit dB μ V/m	Margin dB	Readings dB μ V	Antenna factor 1/m	Preamp dB	Cable loss dB	Height cm	Pol.	Restr. Band
2.402	94.7	-	-	62.2	28.8	0.0	3.7	150	Hor.	-
2.400	58.6	74.7	16.1	26.4	28.8	0.0	3.7	150	Hor.	No
Result measured with the average detector:										
Frequency GHz	Corr. value dB μ V/m	Limit dB μ V/m	Margin dB	Readings dB μ V	Antenna factor 1/m	Preamp dB	Cable loss dB	Height cm	Pol.	Restr. Band
2.402	84.3	-	-	51.8	28.8	0.0	3.7	150	Hor.	-
2.400	48.2	64.3	16.1	15.7	28.8	0.0	3.7	150	Hor.	No
Measurement uncertainty							+2.2 dB / -3.6 dB			

TEST REPORT REFERENCE: R71750_B Edition 1

Band-edge compliance (upper band edge, hopping disabled)										
Result measured with the peak detector:										
Frequency GHz	Corr. value dB μ V/m	Limit dB μ V/m	Margin dB	Readings dB μ V	Antenna factor 1/m	Preamp dB	Cable loss dB	Height cm	Pol.	Restr. Band
2.480	92.5	-	-	59.7	29.0	0.0	3.8	150	Hor.	-
2.485	47.7	74.0	26.3	14.9	29.0	0.0	3.8	150	Hor.	Yes
Result measured with the average detector:										
Frequency GHz	Corr. value dB μ V/m	Limit dB μ V/m	Margin dB	Readings dB μ V	Antenna factor 1/m	Preamp dB	Cable loss dB	Height cm	Pol.	Restr. Band
2.480	82.1	-	-	49.3	29.0	0.0	3.8	150	Hor.	-
2.484	37.3	54.0	16.7	4.5	29.0	0.0	3.8	150	Hor.	Yes
Measurement uncertainty							+2.2 dB / -3.6 dB			

Band-edge compliance (upper band edge, hopping enabled)										
Result measured with the peak detector:										
Frequency GHz	Corr. value dB μ V/m	Limit dB μ V/m	Margin dB	Readings dB μ V	Antenna factor 1/m	Preamp dB	Cable loss dB	Height cm	Pol.	Restr. Band
2.480	92.5	-	-	59.7	29.0	0.0	3.8	150	Hor.	-
2.485	46.8	74.0	27.2	14.0	29.0	0.0	3.8	150	Hor.	Yes
Result measured with the average detector:										
Frequency GHz	Corr. value dB μ V/m	Limit dB μ V/m	Margin dB	Readings dB μ V	Antenna factor 1/m	Preamp dB	Cable loss dB	Height cm	Pol.	Restr. Band
2.480	82.1	-	-	49.3	29.0	0.0	3.8	150	Hor.	-
2.485	36.4	54.0	17.6	3.6	29.0	0.0	3.8	150	Hor.	Yes
Measurement uncertainty							+2.2 dB / -3.6 dB			

Test: Passed

TEST EQUIPMENT USED FOR THE TEST:

29, 31 – 37, 39, 43, 46, 49 – 51, 54

TEST REPORT REFERENCE: R71750_B Edition 1

5.7 RADIATED EMISSIONS

5.7.1 METHOD OF MEASUREMENT (RADIATED EMISSIONS)

The radiated emission measurement is subdivided into five stages.

- A preliminary measurement carried out in a fully anechoic chamber with a fixed antenna height in the frequency range 9 kHz to 1 GHz.
- A final measurement carried out on an outdoor test site without reflecting ground plane and a fixed antenna height in the frequency range 9 kHz to 30 MHz.
- A final measurement carried out on an open area test site with reflecting ground plane and various antenna height in the frequency range 30 MHz to 1 GHz.
- A preliminary measurement carried out in a fully anechoic chamber with a variable antenna distance and height in the frequency range 1 GHz to 25 GHz.
- A final measurement carried out in a fully anechoic chamber with a fixed antenna height in the frequency range 1 GHz to 25 GHz.

All measurements will be carried out with the EUT working on the middle and upper and lower edge of the assigned frequency band. For this reason the hopping function of the EUT has to be disabled.

Preliminary measurement (9 kHz to 30 MHz):

In the first stage a preliminary measurement will be performed in a shielded room with a measuring distance of 3 meters. Tabletop devices will set up on a non-conducting support with a size of 1 m by 1.5 m and a height of 80 cm. Floor-standing devices will be placed directly on the turntable/ground plane. The set up of the Equipment under test will be in accordance to ANSI C63.4-2003 [1].

The frequency range 9 kHz to 30 MHz will be monitored with a spectrum analyser while the system and its cables will be manipulated to find out the configuration with the maximum emission levels if applicable. The EMI Receiver will be set to MAX Hold mode. The EUT and the measuring antenna will be rotated around their vertical axis to found the maximum emissions.

The resolution bandwidth of the spectrum analyser will be set to the following values:

Frequency range	Resolution bandwidth
9 kHz to 150 kHz	200 Hz
150 kHz to 30 MHz	10 kHz

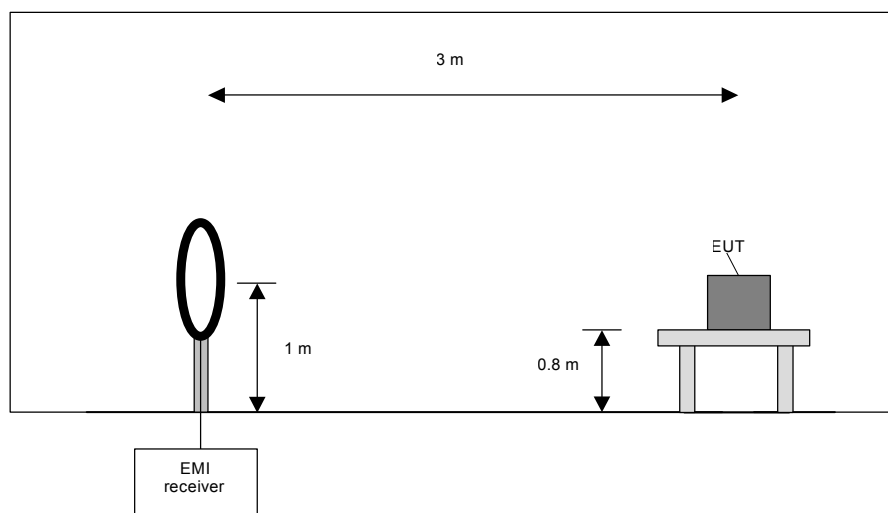

TEST REPORT REFERENCE: R71750_B Edition 1

Preliminary measurement procedure:

Prescans were performed in the frequency range 9 kHz to 150 kHz and 150 kHz to 30 MHz.

The following procedure will be used:

- 1) Monitor the frequency range at horizontal polarisation and a EUT azimuth of 0 °.
- 2) Manipulate the system cables within the range to produce the maximum level of emission.
- 3) Rotate the EUT by 360 ° to maximize the detected signals.
- 4) Make a hardcopy of the spectrum.
- 5) Measure the frequencies of highest detected emission with a lower span and resolution bandwidth to increase the accuracy and note the frequency value.
- 6) Repeat steps 1) to 5) with the other orthogonal axes of the EUT (because of EUT is a module and might be used in a handheld equipment application).
- 7) Rotate the measuring antenna and repeat steps 1) to 5).

Final measurement (9 kHz to 30 MHz):

In the second stage a final measurement will be performed on an open area test site with no conducting ground plane in a measuring distances of 3 m, 10 m and 30 m. In the case where larger measuring distances are required the results will be extrapolated based on the values measured on the closer distances according to Section 15.31 (f) (2) [2]. The final measurement will be performed with a EMI Receiver set to Quasi Peak detector except for the frequency bands 9 kHz to 90 kHz and 110 kHz to 490 kHz where an average detector will be used according Section 15.209 (d) [2].

On the during the preliminary measurement detected frequencies the final measurement will be performed while rotating the EUT and the measuring antenna in the range of 0 ° to 360 ° around their vertical axis until the maximum value is found.

The resolution bandwidth of the EMI Receiver will be set to the following values:

Frequency range	Resolution bandwidth
9 kHz to 150 kHz	200 Hz
150 kHz to 30 MHz	9 kHz

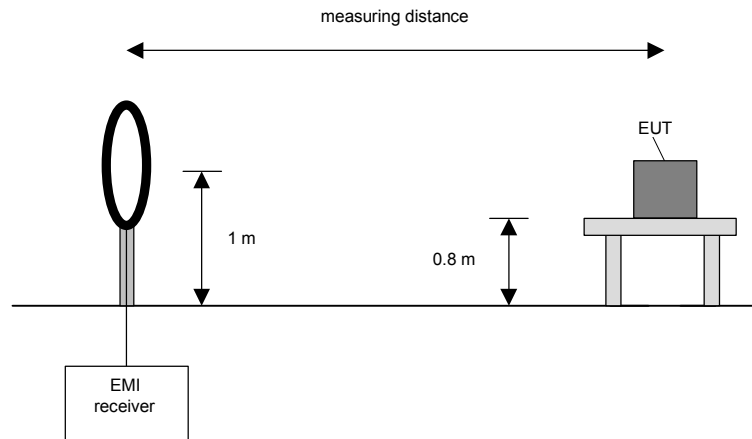

TEST REPORT REFERENCE: R71750_B Edition 1

Final measurement procedure:

The following procedure will be used:

- 1) Monitor the frequency range with the measuring antenna at vertical orientation parallel to the EUT at an azimuth of 0 °.
- 2) Rotate the EUT by 360 ° to maximize the detected signals and note the azimuth and orientation.
- 3) Rotate the measuring antenna to find the maximum and note the value.
- 4) Rotate the measuring antenna and repeat steps 1) to 3) until the maximum value is found.
- 5) Repeat steps 1) to 4) with the other orthogonal axes of the EUT (because of EUT is a module and might be used in a handheld equipment application).

Preliminary measurement (30 MHz to 1 GHz)

In the first stage a preliminary measurement will be performed in a fully anechoic chamber with a measuring distance of 3 meter. Tabletop devices will set up on a non-conducting support with a size of 1 m by 1.5 m and a height of 80 cm. Floor-standing devices will be placed directly on the turntable/ground plane. The set up of the Equipment under test will be in accordance to ANSI C63.4-2003 [1].

The frequency range 30 MHz to 1 GHz will be measured with an EMI Receiver set to MAX Hold mode and a resolution bandwidth of 100 kHz. The measurement will be performed in horizontal and vertical polarisation of the measuring antenna and while rotating the EUT in its vertical axis in the range of 0 ° to 360 °.

The resolution bandwidth of the EMI Receiver will be set to the following values:

Frequency range	Resolution bandwidth
30 MHz to 230 MHz	100 kHz
230 MHz to 1 GHz	100 kHz

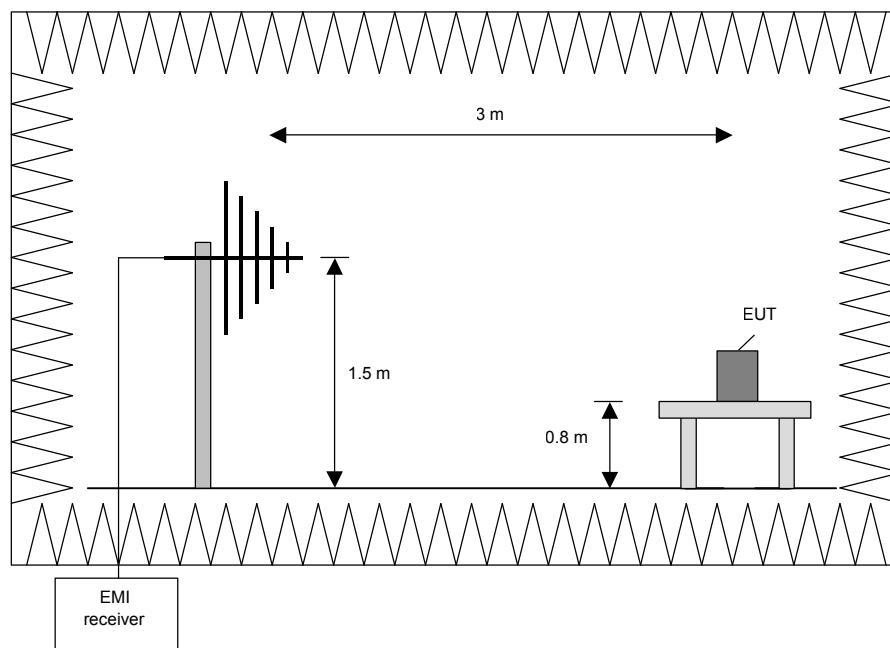

TEST REPORT REFERENCE: R71750_B Edition 1

Procedure preliminary measurement:

Prescans were performed in the frequency range 30 MHz to 230 MHz and 230 MHz to 1 GHz.
The following procedure will be used:

1. Monitor the frequency range at horizontal polarisation and a EUT azimuth of 0 °.
2. Manipulate the system cables within the range to produce the maximum level of emission.
3. Rotate the EUT by 360 ° to maximize the detected signals.
4. Make a hardcopy of the spectrum.
5. Measure the frequency of the detected emissions with a lower span and resolution bandwidth to increase the accuracy and note the frequency value.
6. Repeat 1) to 4) with the other orthogonal axes of the EUT (because of EUT is a module and might be used in a handheld equipment application).
7. Repeat 1) to 5) with the vertical polarisation of the measuring antenna.

Final measurement (30 MHz to 1 GHz)

A final measurement on an open area test site will be performed on selected frequencies found in the preliminary measurement. During this test the EUT will be rotated in the range of 0 ° to 360 °, the measuring antenna will be set to horizontal and vertical polarisation and raised and lowered in the range from 1 m to 4 m to find the maximum level of emissions.

The resolution bandwidth of the EMI Receiver will be set to the following values:

Frequency range	Resolution bandwidth
30 MHz to 1 GHz	120 kHz

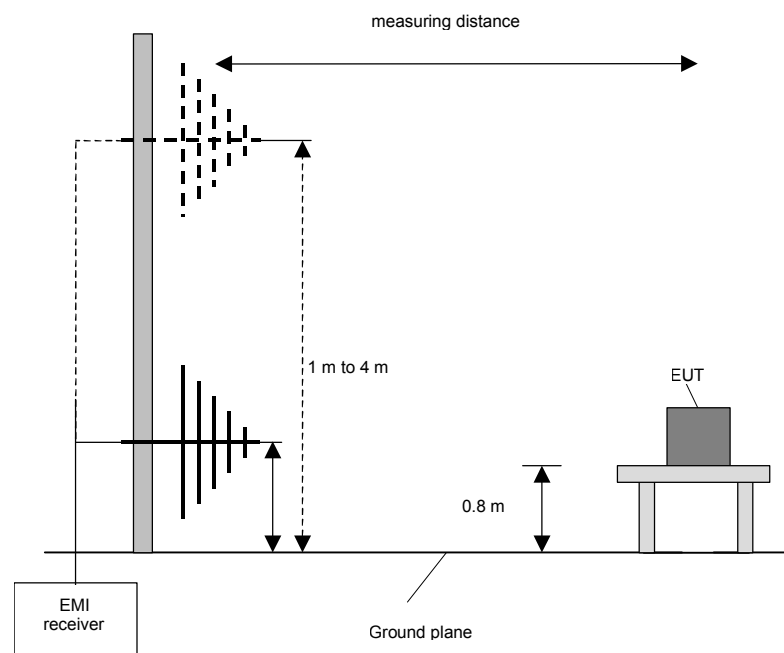

TEST REPORT REFERENCE: R71750_B Edition 1

Procedure final measurement:

The following procedure will be used:

- 1) Measure on the selected frequencies at an antenna height of 1 m and a EUT azimuth of 23 °.
- 2) Move the antenna from 1 m to 4 m and note the maximum value at each frequency.
- 3) Rotate the EUT by 45 ° and repeat 2) until an azimuth of 337 ° is reached.
- 4) Repeat 1) to 3) for the other orthogonal antenna polarization.
- 5) Move the antenna and the turntable to the position where the maximum value is detected.
- 6) Measure while moving the antenna slowly +/- 1 m.
- 7) Set the antenna to the position where the maximum value is found.
- 8) Measure while moving the turntable +/- 45 °.
- 9) Set the turntable to the azimuth where the maximum value is found.
- 10) Measure with Final detector (QP and AV) and note the value.
- 11) Repeat 5) to 10) for each frequency.
- 12) Repeat 1) to 11) for each orthogonal axes of the EUT (because of EUT is a module and might be used in a handheld equipment application).

Preliminary and final measurement (1 GHz to 25 GHz)

This measurement will be performed in a fully anechoic chamber. Tabletop devices will set up on a non-conducting support with a size of 1 m by 1.5 m and a height of 80 cm. Floor-standing devices will be placed directly on the turntable/ground plane. The set up of the Equipment under test will be in accordance to ANSI C63.4-2003 [1].

Preliminary measurement (1 GHz to 25 GHz)

The frequency range will be divided into different sub ranges depending of the frequency range of the used horn antenna. The spectrum analyser set to MAX Hold mode and a resolution bandwidth of 100 kHz. The measurement will be performed in horizontal and vertical polarisation of the measuring antenna, the antenna close to the EUT and while moving the antenna over all sides of the EUT. With the spectrum analyser in CLEAR / WRITE mode the cone of the emission should be found and than the measuring distance will be set to 3 m with the receiving antenna moving in this cone of emission. At this position the final measurement will be carried out.

The resolution bandwidth of the EMI Receiver will be set to the following values:

Frequency range	Resolution bandwidth
1 GHz to 4 GHz	100 kHz
4 GHz to 12 GHz	100 kHz
12 GHz to 18 GHz	100 kHz
18 GHz to 25 GHz	100 kHz

TEST REPORT REFERENCE: R71750_B Edition 1

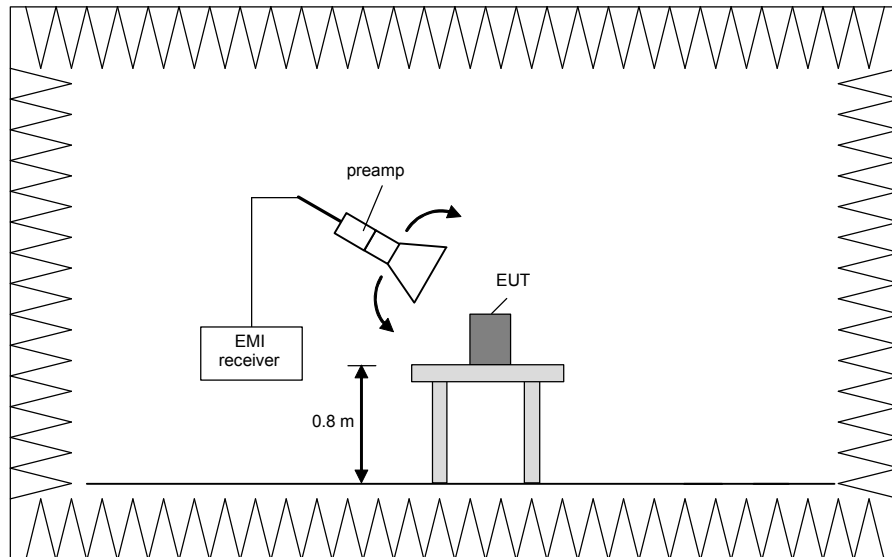

Final measurement (1 GHz to 25 GHz)

The frequency range will be divided into different sub ranges depending of the frequency range of the used horn antenna. The EMI Receiver set to peak and average mode and a resolution bandwidth of 1 MHz. The measurement will be performed in horizontal and vertical polarisation of the measuring antenna and while rotating the EUT in its vertical axis in the range of 0 ° to 360 ° in order to have the antenna inside the cone of radiation.

The resolution bandwidth of the EMI Receiver will be set to the following values:

Frequency range	Resolution bandwidth
1 GHz to 4 GHz	1 MHz
4 GHz to 12 GHz	1 MHz
12 GHz to 18 GHz	1 MHz
18 GHz to 25 GHz	1 MHz

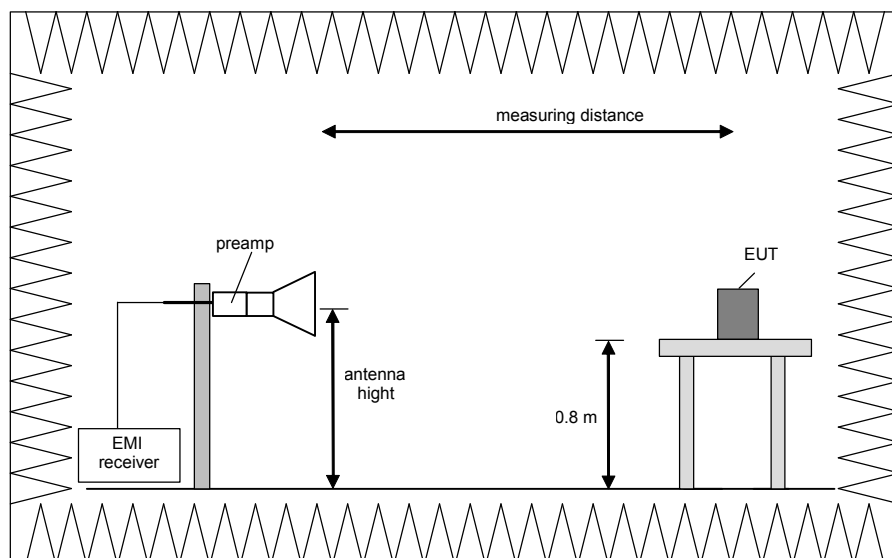

TEST REPORT REFERENCE: R71750_B Edition 1

Procedure of measurement:

The measurements were performed in the frequency range 1 GHz to 4 GHz, 4 GHz to 12 GHz, 12 GHz to 18 GHz and 18 GHz to 25 GHz.

The following procedure will be used:

- 1) Monitor the frequency range at horizontal polarisation and move the antenna over all sides of the EUT (if necessary move the EUT to another orthogonal axis).
- 2) Change the antenna polarisation and repeat 1) with vertical polarisation.
- 3) Make a hardcopy of the spectrum.
- 4) Measure the frequency of the detected emissions with a lower span and resolution bandwidth to increase the accuracy and note the frequency value.
- 5) Change the analyser mode to Clear / Write and found the cone of emission.
- 6) Rotate and move the EUT, so that the measuring distance can be enlarged to 3 m and the antenna will be still inside the cone of emission.
- 7) Measure the level of the detected frequency with the correct resolution bandwidth, with the antenna polarisation and azimuth and the peak and average detector, which causes the maximum emission.
- 8) Repeat steps 1) to 7) for the next antenna spot if the EUT is larger than the antenna beamwidth.

Step 1) to 6) are defined as preliminary measurement.

TEST REPORT REFERENCE: R71750_B Edition 1

5.7.2 TEST RESULTS (RADIATED EMISSIONS)

5.7.2.1 PRELIMINARY MEASUREMENT (9 kHz to 25 GHz)

Ambient temperature	20 °C	Relative humidity	45 %
---------------------	-------	-------------------	------

- Position of EUT: The EUT was set-up on a non-conducting table of a height of 0.8 m. The distance between EUT and antenna was 3 m.
- Cable guide: No cables were connected to the EUT during this measurement. For further information of test set-up refer to the pictures in annex A of this test report.
- Test record: All results are shown in the following.
- Supply voltage: During all measurements the EUT was supplied with 13.8 V DC via program adaptor.
- Remark: As pre-tests have shown, the emissions in the frequency range 9 kHz to 1 GHz are not depending on the transmitter operation mode or frequency. Therefore the emissions in this frequency range were measured only with the transmitter operates in operation mode 2.

71750_28.wmf: (9 kHz to 150 kHz):

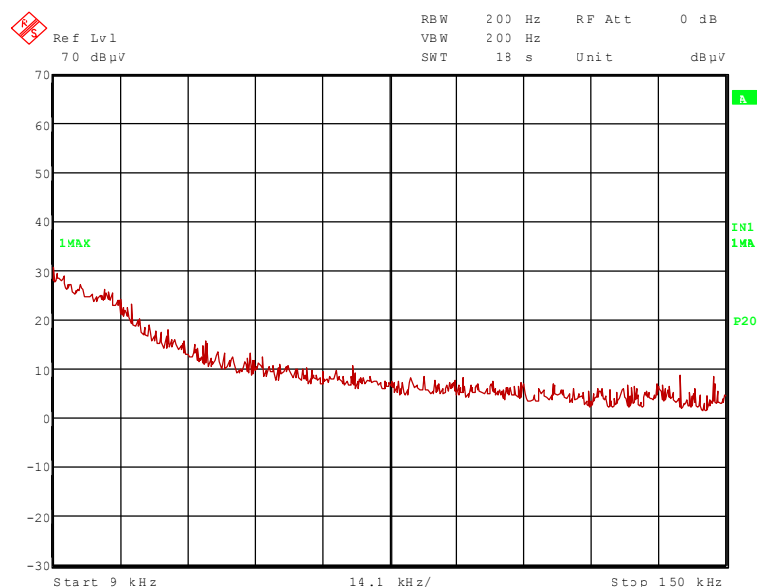

TEST EQUIPMENT USED FOR THE TEST:

29, 31 – 37, 39, 43, 46, 49 – 51, 54

TEST REPORT REFERENCE: R71750_B Edition 1

71750_27.wmf: (150 kHz to 1 MHz):

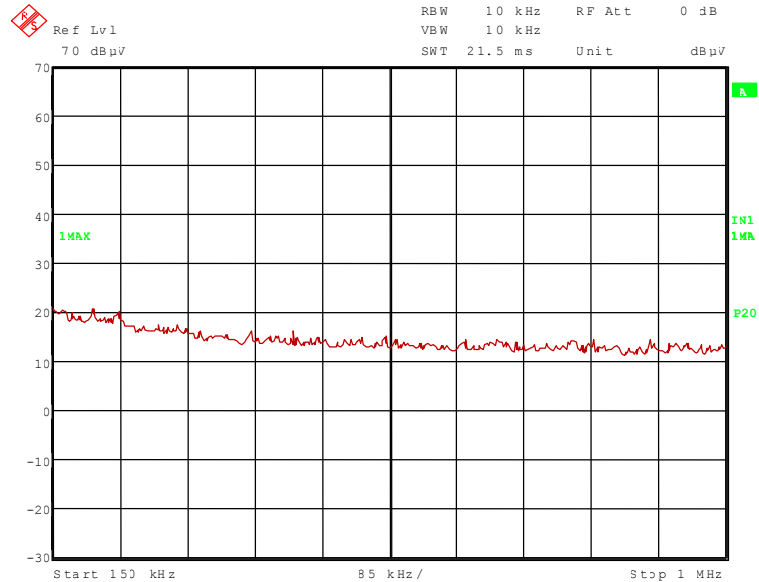

71750_26.wmf: (1 MHz to 30 MHz)

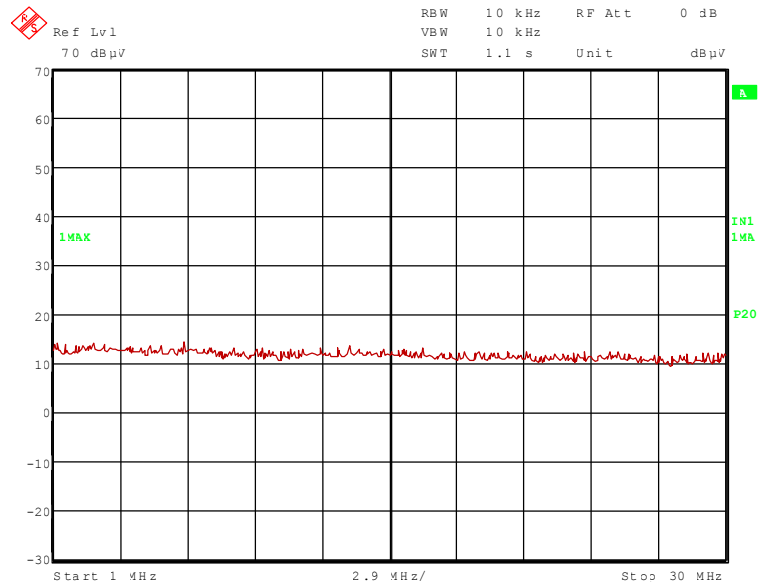

No significant frequencies above the noise floor of the system were found during the preliminary radiated emission test inside this frequency range, so no measurements were carried out on the outdoor test site.

TEST REPORT REFERENCE: R71750_B Edition 1

71750_19.wmf (30 MHz to 230 MHz):

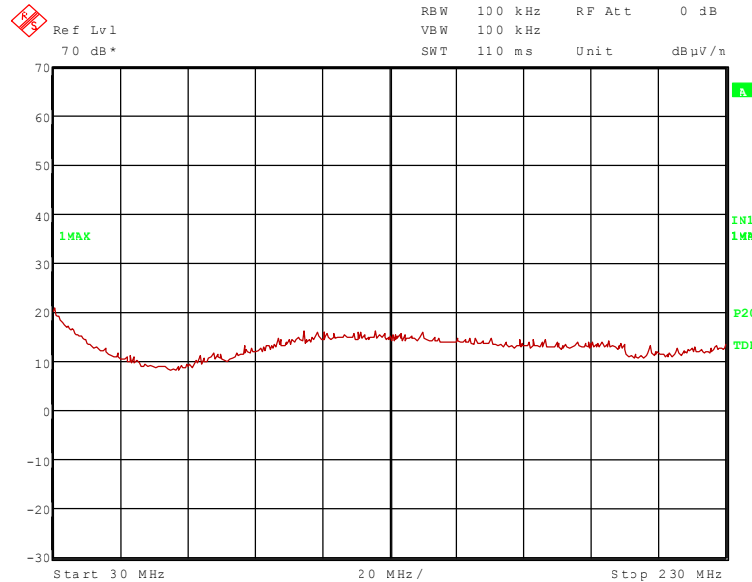

71750_20.wmf (230 MHz to 1 GHz):

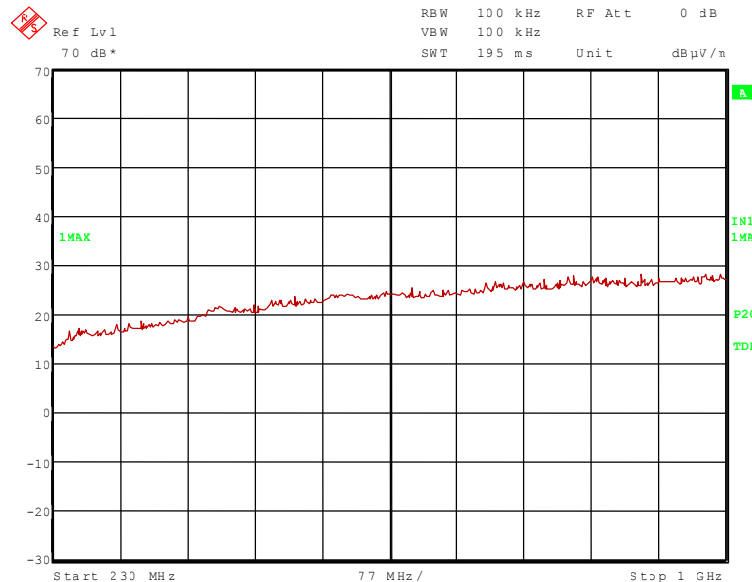

No significant frequencies above the noise floor of the system were found during the preliminary radiated emission test inside this frequency range, so no measurements were carried out on the open area test site.

TEST REPORT REFERENCE: R71750_B Edition 1

Transmitter operates at the lower end of the assigned frequency band (operation mode 1)

71750_2.wmf (1 GHz to 4 GHz):

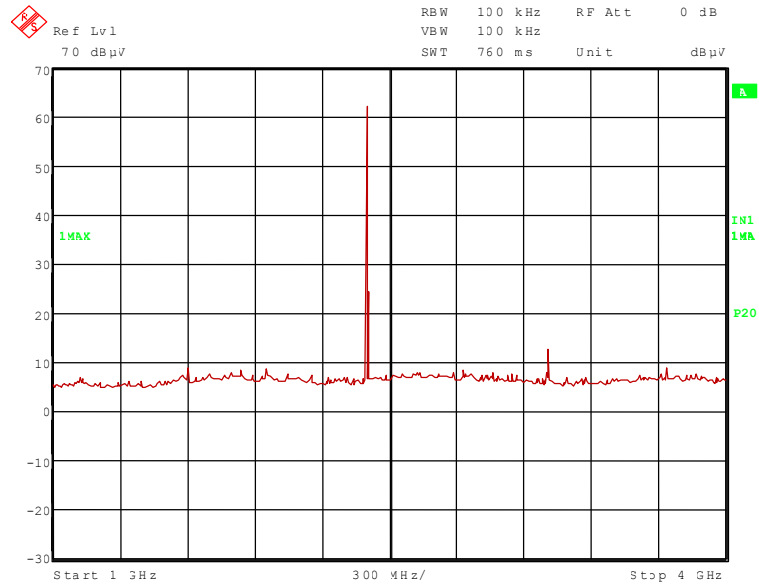

71750_6.wmf (4 GHz to 12 GHz):

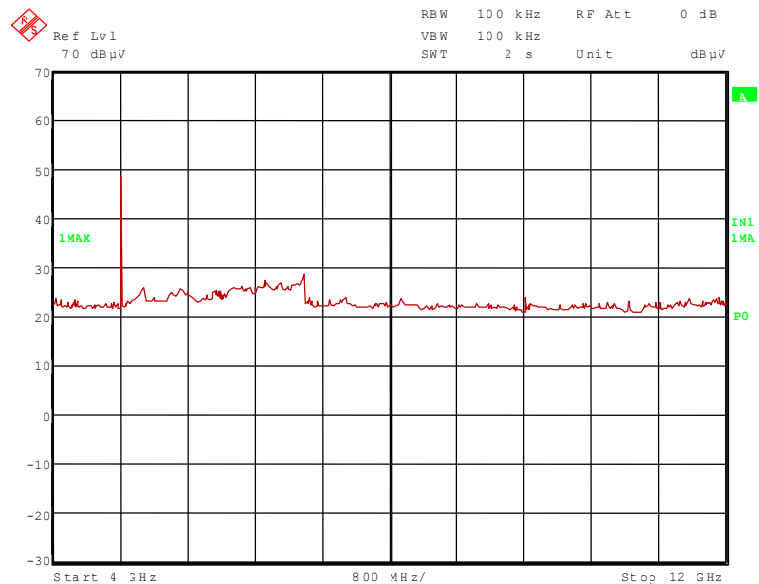

TEST REPORT REFERENCE: R71750_B Edition 1

71750_9.wmf (12 GHz to 18 GHz):

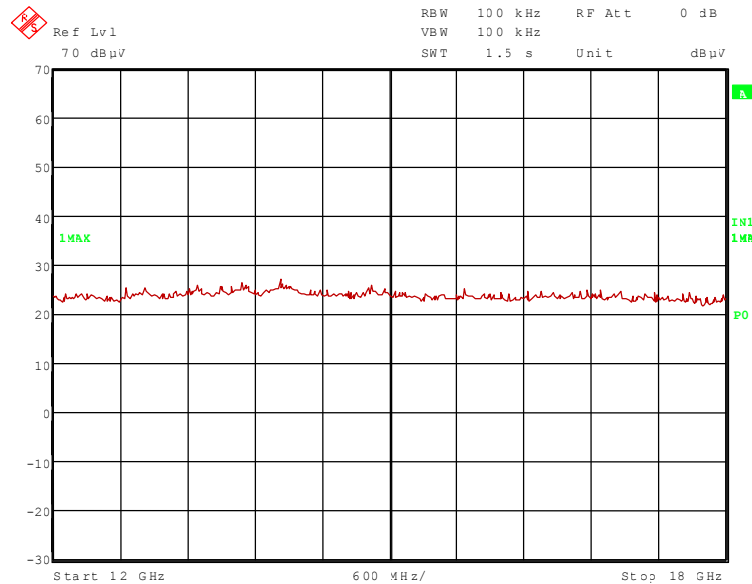

71750_14.wmf (18 GHz to 25 GHz):

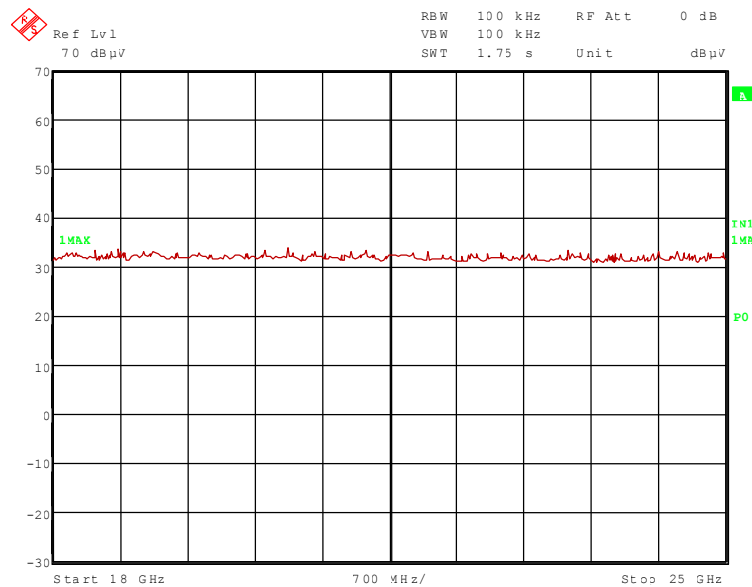

The following frequency was found inside the restricted bands during the preliminary radiated emission test:

- 4.804 GHz.

The following frequencies were found outside the restricted bands during the preliminary radiated emission test:

- 2.402 GHz and 3.204 GHz.

These frequencies have to be measured in a final measurement. The results were presented in the following.

TEST REPORT REFERENCE: R71750_B Edition 1

71750_10.wmf (12 GHz to 18 GHz):

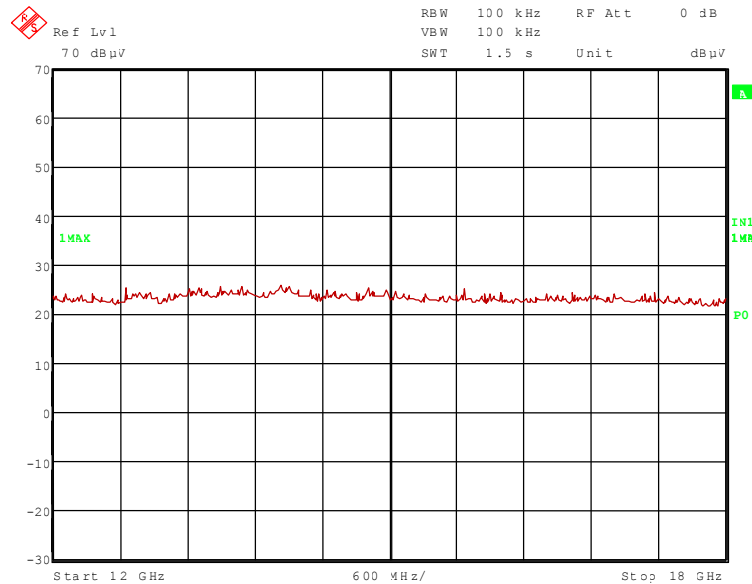

71750_13.wmf (18 GHz to 25 GHz):

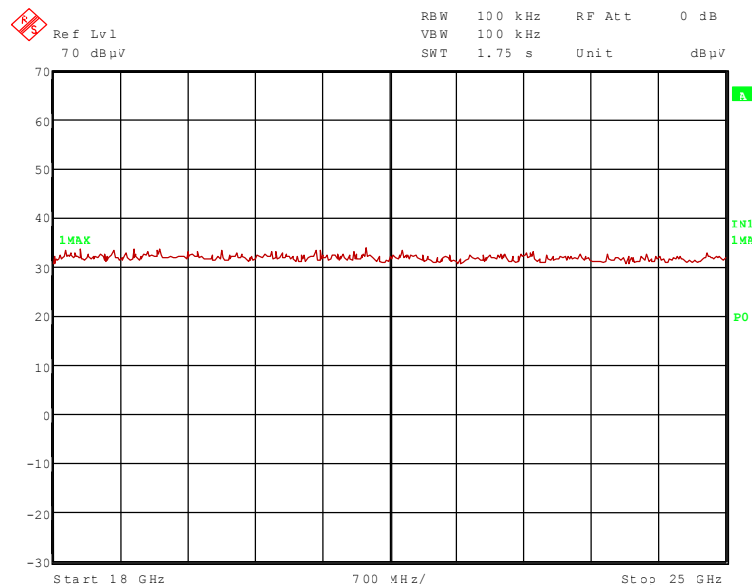

The following frequency was found inside the restricted bands during the preliminary radiated emission test:

- 4.882 GHz.

The following frequencies were found outside the restricted bands during the preliminary radiated emission test:

- 2.441 GHz and 3.256 GHz.

These frequencies have to be measured in a final measurement. The results were presented in the following.

TEST REPORT REFERENCE: R71750_B Edition 1

5.7.2.2 FINAL MEASUREMENT (1 GHz to 25 GHz)

Ambient temperature	20 °C	Relative humidity	45 %
---------------------	-------	-------------------	------

- Position of EUT: The EUT was set-up on a non-conducting table of a height of 0.8 m. The distance between EUT and antenna was 3 m.
- Cable guide: No cables were connected to the EUT during this measurement. For further information of test set-up refer to the pictures in annex A of this test report.
- Test record: All results are shown in the following.
- Supply voltage: During all measurements the EUT was supplied with 13.8 V DC via program adaptor.
- Resolution bandwidth: For all measurements a resolution bandwidth of 1 MHz was used.

Transmitter operates at the lower end of the assigned frequency band (operation mode 1)

Result measured with the peak detector:

Frequency GHz	Corr. value dB μ V/m	Limit dB μ V/m	Margin dB	Readings dB μ V	Antenna factor 1/m	Preamp dB	Cable loss dB	Height cm	Pol.	Restr. Band
2.402	94.7	-	-	62.2	28.8	0.0	3.7	150	Hor.	-
3.204	55.7	74.7	19.0	20.1	31.3	0.0	4.3	150	Hor.	No
4.804	66.7	74.0	7.3	53.4	33.7	25.7	5.3	150	Vert.	Yes
Measurement uncertainty							+2.2 dB / -3.6 dB			

Result measured with the average detector:

Frequency GHz	Corr. value dB μ V/m	Limit dB μ V/m	Margin dB	Readings dB μ V	Antenna factor 1/m	Preamp dB	Cable loss dB	Height cm	Pol.	Restr. Band
2.402	84.3	-	-	51.8	28.8	0.0	3.7	150	Hor.	-
3.204	43.0	64.3	21.3	7.4	31.3	0.0	4.3	150	Hor.	No
4.804	52.8	54.0	1.2	39.5	33.7	25.7	5.3	150	Vert.	Yes
Measurement uncertainty							+2.2 dB / -3.6 dB			

TEST REPORT REFERENCE: R71750_B Edition 1

Transmitter operates at the middle of the assigned frequency band (operation mode 2)

Result measured with the peak detector:

Frequency GHz	Corr. value dB μ V/m	Limit dB μ V/m	Margin dB	Readings dB μ V	Antenna factor 1/m	Preamp dB	Cable loss dB	Height cm	Pol.	Restr. Band
2.441	96.7	-	-	64.1	28.9	0.0	3.7	150	Hor.	-
3.256	56.8	76.7	19.9	22.1	31.4	0.0	4.3	150	Hor.	No
4.882	66.8	74.0	7.2	53.4	33.8	25.7	5.3	150	Vert.	Yes
Measurement uncertainty						+2.2 dB / -3.6 dB				

Result measured with the average detector:

Frequency GHz	Corr. value dB μ V/m	Limit dB μ V/m	Margin dB	Readings dB μ V	Antenna factor 1/m	Preamp dB	Cable loss dB	Height cm	Pol.	Restr. Band
2.441	86.4	-	-	53.8	28.9	0.0	3.7	150	Hor.	-
3.256	46.2	66.4	20.2	10.5	31.4	0.0	4.3	150	Hor.	No
4.882	52.3	54.0	1.7	38.9	33.8	25.7	5.3	150	Vert.	Yes
Measurement uncertainty						+2.2 dB / -3.6 dB				

TEST REPORT REFERENCE: R71750_B Edition 1

Transmitter operates at the upper end of the assigned frequency band (operation mode 3)

Result measured with the peak detector:

Frequency GHz	Corr. value dB μ V/m	Limit dB μ V/m	Margin dB	Readings dB μ V	Antenna factor 1/m	Preamp dB	Cable loss dB	Height cm	Pol.	Restr. Band
2.480	92.5	-	-	59.7	29.0	0.0	3.8	150	Hor.	-
3.308	63.3	74.0	10.7	27.5	31.5	0.0	4.3	150	Hor.	No
4.960	64.1	74.0	9.9	50.4	34.0	25.6	5.3	150	Vert.	Yes
7.440	54.5	74.0	19.5	34.9	37.3	24.5	6.8	150	Vert.	Yes
Measurement uncertainty						+2.2 dB / -3.6 dB				

Result measured with the average detector:

Frequency GHz	Corr. value dB μ V/m	Limit dB μ V/m	Margin dB	Readings dB μ V	Antenna factor 1/m	Preamp dB	Cable loss dB	Height cm	Pol.	Restr. Band
2.480	82.1	-	-	49.3	29.0	0.0	3.8	150	Hor.	-
3.308	50.3	62.1	11.8	14.5	31.5	0.0	4.3	150	Hor.	No
4.960	42.7	54.0	11.3	29.0	34.0	25.6	5.3	150	Vert.	Yes
7.440	41.0	54.0	13.0	21.4	37.3	24.5	6.8	150	Vert.	Yes
Measurement uncertainty						+2.2 dB / -3.6 dB				

Test: Passed

TEST EQUIPMENT USED FOR THE TEST:

29, 31 – 37, 39, 43, 46, 49 – 51, 54

TEST REPORT REFERENCE: R71750_B Edition 1

6 TEST EQUIPMENT AND ANCILLARIES USED FOR TESTS

TEST REPORT REFERENCE: R71750_B Edition 1

No.	Test equipment	Type	Manufacturer	Serial No.	PM. No.	Cal. Date	Cal. due
14	Open area test site	-	Phoenix Test-Lab	-	480085	Weekly verification (system cal.)	
15	Measuring receiver	ESCS30	Rohde & Schwarz	828985/014	480270	02/27/2008	02/2010
16	Controller	HD100	Deisel	100/670	480139	-	-
17	Turntable	DS420HE	Deisel	420/620/80	480087	-	-
18	Antenna support	AS615P	Deisel	615/310	480086	-	-
19	Antenna	CBL6111 A	Chase	1643	480147	08/01/2007	08/2012
20	EMI Software	ES-K1	Rohde & Schwarz	-	480111	-	-
29	Fully anechoic chamber M20	-	Albatross Projects	B83107-E2439-T232	480303	Weekly verification (system cal.)	
31	Measuring receiver	ESI 40	Rohde & Schwarz	100064	480355	02/25/2008	02/2010
32	Controller	HD100	Deisel	100/670	480326	-	-
33	Turntable	DS420HE	Deisel	420/620/80	480315	-	-
34	Antenna support	AS615P	Deisel	615/310	480187	-	-
35	Antenna	CBL6112 B	Chase	2688	480328	10/11/2005	10/2010
36	Antenna	3115 A	EMCO	9609-4918	480183	08/04/2003	08/2008
37	Standard Gain Horn 11.9 GHz – 18 GHz	18240-20	Flann Microwave	483	480294	Six month verification (system cal.)	
39	Standard Gain Horn 17.9 GHz – 26.7 GHz	20240-20	Flann Microwave	411	480297	Six month verification (system cal.)	
43	RF-cable No. 30	RTK 081	Rosenberger	-	410141	Weekly verification (system cal.)	
44	RF-cable No. 31	RTK 081	Rosenberger	-	410142	Weekly verification (system cal.)	
46	RF-cable 1m	KPS-1533-400-KPS	Insulated Wire	-	480301	Six month verification (system cal.)	
49	Preamplifier	JS3-00101200-23-5A	Miteq	681851	480337	Six month verification (system cal.)	
50	Preamplifier	JS3-12001800-16-5A	Miteq	571667	480343	Six month verification (system cal.)	
51	Preamplifier	JS3-18002600-20-5A	Miteq	658697	480342	Six month verification (system cal.)	
54	Power supply	TOE 8852	Toellner	51712	480233	11/27/2006	11/2008

TEST REPORT REFERENCE: R71750_B Edition 1

7 LIST OF ANNEXES

ANNEX A	PHOTOGRAPHS OF THE TEST SET-UPS:	5 pages
	CKII, test set-up fully anechoic chamber	71750_j.jpg
	CKII, test set-up fully anechoic chamber	71750_m.jpg
	CKII, test set-up fully anechoic chamber	71750_i.jpg
	CKII, test set-up fully anechoic chamber	71750_e.jpg
	CKII, test set-up fully anechoic chamber	71750_c.jpg
ANNEX B	INTERNAL PHOTOGRAPHS OF THE TEST SAMPLE:	9 pages
	CKII, internal view	71750_6.jpg
	CKII, main PCB, top view	71750_2.jpg
	CKII, main PCB, bottom view	71750_4.jpg
	CKII, main PCB, bottom view, cover removed	71750_8.jpg
	CKII, GSM coupler PCB, top view	71750_11.jpg
	CKII, GSM coupler PCB, bottom view	71750_13.jpg
	CKII, ancillary PCB, top view	71750_7.jpg
	CKII, ancillary PCB, bottom view	71750_5.jpg
	CKII, detail view to sample with temporary antenna connector and external power supply	71750_1.jpg
ANNEX C	EXTERNAL PHOTOGRAPHS OF THE TEST SAMPLE:	3 pages
	CKII, 3D view 1	71750_15.jpg
	CKII, 3D view 2	71750_14.jpg
	CKII, Type plate view	71750_3.jpg
ANNEX D	ADDITIONAL RESULTS FOR INDUSTRY CANADA:	5 pages