

Product Labels

Advanced Telecommunication Module 2 (ATM-02) Roof and Trunk Version

Rev. 1.2

Approved



peiker acustic confidential and proprietary

Type: ATM-02-XXX-Y1
Model:
Internal peiker product ID: 2609-085-xxx-yy / 2609-086-xxx-yy
Status: Approved
Revision: 1.2
Date: 20.12.2017

1 Change documentation

Date	Revision	Name	Changes / Comment
24.11.2016	Rev 0.1	M. Fleckenstein	Initial version
06.03.2017	Rev 0.2	M. Fleckenstein	Update label size
11.07.2017	Rev 0.3	A. Froidl	Update label content, countries
28.07.2017	Rev 0.4	M. Fleckenstein	Added label artwork examples
10.10.2017	Rev 0.5	A. Froidl	Add Trunk versions
24.10.2017	Rev 0.6	A. Froidl	Add "Real Time Monitoring" string for China version
22.11.2017	Rev 0.7	M. Fleckenstein	Edit FCC/IC ID, Edit Israel requirement
30.11.2017	Rev 0.8	A. Froidl	Redesign for less space and more information
05.11.2017	Rev 1.0	A. Froidl	Add final Label pictures. Approval.
14.12.2017	Rev 1.1	M. Fleckenstein	Corrected rated current and added DC symbol, corrected legal form of company
20.12.2017	Rev 1.2	A. Froidl	Add new Label pictures. Correct current rating.

Notice

The information in this document has been carefully reviewed and is believed to be accurate. Nevertheless, this document is subject to change without notice, and peiker acoustic assumes no responsibility for any inaccuracies that may be contained in this document and makes no commitment to update the contained information, or to notify a person or organization of any updates. Peiker acoustic reserves the right to make changes to the product, at any time, in order to improve reliability, function or design. Peiker acoustic does not represent that products described herein are free from patent infringement or from any other third party right. No part of this document may be reproduced, adapted or transmitted in any form or by any means for any purpose, except as explicitly allowed in a written agreement signed by peiker acoustic. Peiker acoustic or its affiliates may have patents or pending patent applications, trademarks, copyrights or other intellectual property rights that apply to the ideas, material and information expressed herein.

Confidential. All rights reserved. This document is peiker acoustic GmbH restricted document. According to the Standards of Business Conduct, this document may not be shared outside peiker acoustic GmbH. This document may be shared with the customer, if appropriate agreement for professional services exists.

Contents

1	Change documentation.....	2
2	Introduction	4
2.1.	Scope	4
2.1.1.	Purpose of the document.....	4
2.1.2.	Contact information.....	4
3	Product Labels	5
3.1.	Content of label.....	5
3.1.1.	General information for all variants	5
3.1.2.	European variant.....	6
3.1.3.	US Variant.....	7
3.1.4.	China Variant.....	8
3.1.5.	ROW Variant.....	9
3.1.6.	Mexico Variant	10
3.2.	Size of the label elements.....	11
3.3.	Position of the label on the device.....	12
3.3.1.	ATM-02-XXX-R1	12
3.3.2.	ATM-02-XXX-T1	12
4	Battery Label	13

2 Introduction

2.1. Scope

2.1.1. Purpose of the document

This document gives an overview about the labels placed on the product and parts of the Advanced Telecommunication Module 2 (ATM-02).

2.1.2. Contact information

peiker acustic GmbH
Valeo peiker Telematics

Max-Planck-Straße 28-32
D-61381 Friedrichsdorf
Germany

<http://www.peiker.de>
info@peiker.de

3 Product Labels

The proposed product label design is shown in a draft version by the following pictures depending on the variant. If no size specified the text and logo should be readable.

3.1. Content of label





3.1.1. General information for all variants

Element	Content
Model Name	ATM-02-XXX-Y1 (XXX= ECE/US/CHN/ROW/MEX); Y=R/T
Type	
Manufacturer/brand name	peiker acustic GmbH
Postal address of manufacturer	P.O.Box 1446, D-61365 Friedrichsdorf
Serial number / unique ID	?????????? (10 digit number)
Hardware version number	103.00X.00X / 202.00X.00X
Software version number	001.0XX.0XX
Voltage / Rating	14VDC / 1A

3.1.2. European variant

ATM-02-ECE-Y1			
<p>BMW 1D 8706761 01 84.10 10/07/17 550760-10 </p> <p>Model: ATM-02-ECE-R1 Ser.: 1000072455 IMEI: 35681505-000121-4 EUICCID: 89314404000078555159 HW/SW: 103.00X.00X / 001.0XX.0XX peiker acoustic GmbH P.O.Box 1446, D-61365 Friedrichsdorf Assembled in Germany 14VDC / 1A</p>	<p>EU, Turkey, Macedonia:</p> <p>Serbia, Malaysia, Taiwan (BSMI + NCC)</p> <p>Russia</p> <p>Singapore (17x9mm)</p> <p>UAE</p> <p>South Africa (OtD)</p>	<p>CE min 5mm high</p> <p> MCMC ABCD12345678 DXXXX</p> <p> CCXXxxxLPyyyZz</p> <p>EAC</p> <p>Complies with IMDA Standards [Dealer's Licence No.]</p> <p>TRA REGISTERED No: nnnnnn DEALER No: xxxxxxx</p> <p> ICASA TA XXXX-YYYY</p>	<p>BMW 1D 1 234 567 01 84.10 00/00/00 550760-10 </p> <p>Model: ATM-02-ECE-R1 Ser.: 0000000000 IMEI: 00000000-000000-0 EUICCID: 00000000000000000000 HW/SW: 000.000.000 / 000.000.000 peiker acoustic GmbH P.O. Box 1446, D-61365 Friedrichsdorf Assembled in Germany 14VDC / 1A</p> <p> MCMC ABCD12345678 TA XXXX-YYYY</p> <p> CCXXxxxLPyyyZz</p> <p>Complies with IMDA Standards [Dealer's Lic. No.]</p> <p>TRA REGISTERED No.: nnnnnn DEALER No.: xxxxxxx</p> <p>DXXXX</p>
<p>BMW 1D 8706766 01 84.10 10/07/17 550760-10 </p> <p>Model: ATM-02-ECE-T1 Ser.: 1000072455 IMEI: 35681505-000121-4 EUICCID: 89314404000078555159 HW/SW: 202.00X.00X / 001.0XX.0XX peiker acoustic GmbH P.O.Box 1446, D-61365 Friedrichsdorf Assembled in Germany 14VDC / 1A</p>	<p>Mozambique: n/a India: n/a Kuwait: n/a</p> <p>For information only:</p> <p>Israel:</p> <p>ERA Glonass: -ERA Glonass System Name - ERA Glonass SW Unit EU eCall: KBA: E1 Logo + Nummer</p>	<p>The importer for Israel must affix a label in Hebrew language (example):</p> <p></p>	<p>BMW 1D 1 234 567 01 84.10 00/00/00 550760-10 </p> <p>Model: ATM-02-ECE-T1 Ser.: 0000000000 IMEI: 00000000-000000-0 EUICCID: 00000000000000000000 HW/SW: 000.000.000 / 000.000.000 peiker acoustic GmbH P.O. Box 1446, D-61365 Friedrichsdorf Assembled in Germany 14VDC / 1A</p> <p> MCMC ABCD12345678 TA XXXX-YYYY</p> <p> CCXXxxxLPyyyZz</p> <p>Complies with IMDA Standards [Dealer's Lic. No.]</p> <p>TRA REGISTERED No.: nnnnnn DEALER No.: xxxxxxx</p> <p>DXXXX</p>

















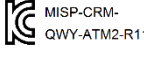

3.1.3. US Variant

ATM-02-US-Y1			
<p>BMW 1D 8706762 01 84.10 10/07/17 550760-10  Model: ATM-02-US-R1 Ser.: 1000072455 IMEI: 35681505-000121-4 EUICCID: 89314404000078555159 HW/SW: 103.00X.00X / 001.0XX.0XX peiker acustic GmbH P.O.Box 1446, D-61365 Friedrichsdorf Assembled in Germany 14VDC / 1A</p>	<p>USA Trunk: FCC ID QWY-ATM2-T11 Roof: FCC ID QWY-ATM2-R11</p> <p>Canada ISED Trunk: IC 6588A-ATM2T11 Roof: IC 6588A-ATM2R11</p> <p>Europe (OtD)</p>	<p style="text-align: center;">CE</p> <p style="text-align: center;">IFT: xxxxxx</p>	<p>BMW 1D 1 234 567 01 84.10 00/00/00 550760-10  Model: ATM-02-US-R1 Ser.: 0000000000 IMEI: 00000000-000000-0 EUICCID: 00000000000000000000 HW/SW: 000.000.000 / 000.000.000 peiker acustic GmbH P.O. Box 1446, D-61365 Friedrichsdorf Assembled in Germany 14VDC / 1A</p> <p>FCC ID QWY-ATM2-R11 CE IC 6588A-ATM2R11 IFT: xxxxxx</p>
<p>BMW 1D 8706767 01 84.10 10/07/17 550760-10  Model: ATM-02-US-T1 Ser.: 1000072455 IMEI: 35681505-000121-4 EUICCID: 89314404000078555159 HW/SW: 202.00X.00X / 001.0XX.0XX peiker acustic GmbH P.O.Box 1446, D-61365 Friedrichsdorf Assembled in Germany 14V DC / 1A</p>	<p>Mexico (OtD)</p>		<p>BMW 1D 1 234 567 01 84.10 00/00/00 550760-10  Model: ATM-02-US-T1 Ser.: 0000000000 IMEI: 00000000-000000-0 EUICCID: 00000000000000000000 HW/SW: 000.000.000 / 000.000.000 peiker acustic GmbH P.O. Box 1446, D-61365 Friedrichsdorf Assembled in Germany 14VDC / 1A</p> <p>FCC ID QWY-ATM2-T11 CE IC 6588A-ATM2T11 IFT: xxxxxx</p>





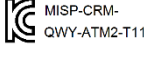

3.1.4. China Variant

ATM-02-CHN-Y1			
<p>车载无线终端 Ser.: 0000000000 型号: ATM-02-CHN-R1 输入: 14V DC == 1A CMIIT ID:0000xx0000 00/00/00 IMEI: 00000000-000000-0 制造商: peiker acustic GmbH 德国制造 Real-Time Monitoring 3.0</p> <hr/> <p>BMW 1D 8706763 01 84.10 550760-10 </p> <p>HW: 103.00X.00X SW: 001.0XX.0XX ICCID: 89314404000078555159 peiker acustic GmbH P.O. Box 1446, D-61365 Friedrichsdorf</p>	<p>China: SRRC, CCC, NAL (text in Chinese language)</p> <p>Additional NAL label provided by national authority to be attached to each device</p> <p>China: Real-Time Monitoring requirement:</p>	<p>CMIIT ID XXXXYZNNNN</p> <p>Real-Time Monitoring 3.0</p>	<p>车载无线终端 Ser.: 0000000000 型号: ATM-02-CHN-R1 输入: 14VDC == 1A CMIIT ID: XXXXYZNNNN 00/00/00 IMEI: 00000000-000000-0 制造商: peiker acustic GmbH 德国制造 Real-Time Monitoring 3.0</p> <p>BMW 1D 1 234 567 01 84.10 550760-10 </p> <p>HW: 000.000.000 SW: 000.000.000 ICCID: 00000000000000000000 peiker acustic GmbH P.O. Box 1446, D-61365 Friedrichsdorf</p>
<p>车载无线终端 Ser.: 0000000000 型号: ATM-02-CHN-T1 输入: 14V DC == 1A CMIIT ID:0000xx0000 00/00/00 IMEI: 00000000-000000-0 制造商: peiker acustic GmbH 德国制造 Real-Time Monitoring 3.0</p> <hr/> <p>BMW 1D 8706763 01 84.10 550760-10 </p> <p>HW: 202.00X.00X SW: 001.0XX.0XX ICCID: 89314404000078555159 peiker acustic GmbH P.O. Box 1446, D-61365 Friedrichsdorf</p>	<p>Hongkong: Macao:</p> <p>South Africa (OtD)</p>	<p>Certified for use in Hong Kong 經認證可在香港使用 Certificate No. 證書號碼 ZZZZZYXXXXXX</p> TA XXXX-YYYY	<p>车载无线终端 Ser.: 0000000000 型号: ATM-02-CHN-T1 输入: 14VDC == 1A CMIIT ID: XXXXYZNNNN 00/00/00 IMEI: 00000000-000000-0 制造商: peiker acustic GmbH 德国制造 Real-Time Monitoring 3.0</p> <p>BMW 1D 1 234 567 01 84.10 550760-10 </p> <p>HW: 000.000.000 SW: 000.000.000 ICCID: 00000000000000000000 peiker acustic GmbH P.O. Box 1446, D-61365 Friedrichsdorf</p>

3.1.5. ROW Variant

ATM-02-ROW-Y1			
<p>BMW 1D 8706764 01 84.10 10/07/17 550760-10 </p> <p>Model: ATM-02-ROW-R1 Ser.: 1000072455 IMEI: 35681505-000121-4 EUICCID: 89314404000078555159 HW/SW: 103.00X.00X / 001.0XX.0XX peiker acoustic GmbH P.O.Box 1446, D-61365 Friedrichsdorf Assembled in Germany 14VDC / 1A</p>	<p>Brazil</p> <p>Australia, New Zealand</p> <p>Japan</p> <p>Korea</p> <p>South Africa</p> <p>Botswana</p> <p>Lesotho: n/a</p> <p>Mozambique: n/a</p> <p>Swaziland: n/a</p> <p>Zimbabwe: n/a</p> <p>Namibia: n/a</p>	   <p>202-XXXXXX ABCD YY-xxxx 202</p>   <p>TA XXXX-YYYY</p> <p>BTA Registered No: nnnnnnnn</p>	<p>BMW 1D 1 234 567 01 84.10 00/00/00 550760-10 </p> <p>Model: ATM-02-ROW-R1 Ser.: 0000000000 IMEI: 00000000-000000-0 EUICCID: 00000000000000000000 HW/SW: 000.000.000 / 000.000.000 peiker acoustic GmbH P.O. Box 1446, D-61365 Friedrichsdorf Assembled in Germany 14VDC / 1A</p>    <p>202-xxxxxx ABCD YY-xxx</p>   <p>TA XXXX-YYYY</p> <p>BTA Registered No: nnnnnnnn IFT: xxxxxx</p>
<p>BMW 1D 8706769 01 84.10 10/07/17 550760-10 </p> <p>Model: ATM-02-ROW-T1 Ser.: 1000072455 IMEI: 35681505-000121-4 EUICCID: 89314404000078555159 HW/SW: 202.00X.00X / 001.0XX.0XX peiker acoustic GmbH P.O.Box 1446, D-61365 Friedrichsdorf Assembled in Germany 14VDC / 1A</p>	<p>Mexico (OtD)</p> <p>Thailand: not mandatory for devices mounted in vehicle, spare parts to be marked by local importer with NBTC label</p> <p>Europe (OtD)</p>	<p>IFT: xxxxxx</p> <p>CE</p>	<p>BMW 1D 1 234 567 01 84.10 00/00/00 550760-10 </p> <p>Model: ATM-02-ROW-T1 Ser.: 0000000000 IMEI: 00000000-000000-0 EUICCID: 00000000000000000000 HW/SW: 000.000.000 / 000.000.000 peiker acoustic GmbH P.O. Box 1446, D-61365 Friedrichsdorf Assembled in Germany 14VDC / 1A</p>    <p>202-xxxxxx ABCD YY-xxx</p>   <p>TA XXXX-YYYY</p> <p>BTA Registered No: nnnnnnnn IFT: xxxxxx</p>

3.1.6. Mexico Variant

ATM-02 MEX-Y1			
<p>BMW 1D 8706765 01 84.10 10/07/17 550760-10 </p> <p>Model: ATM-02-MEX-R1 Ser.: 1000072455 IMEI: 35681505-000121-4 EUICCID: 89314404000078555159 HW/SW: 103.00X.00X / 001.0XX.0XX peiker acustic GmbH P.O.Box 1446, D-61365 Friedrichsdorf Assembled in Germany 14VDC / 1A</p>	<p>USA Trunk: FCC ID QWY-ATM2-T11 Roof: FCC ID QWY-ATM2-R11</p> <p>Mexico IFT: xxxxxx</p> <p>Europe (OtD)</p>		<p>BMW 1D 1 234 567 01 84.10 00/00/00 550760-10 </p> <p>Model: ATM-02-MEX-R1 Ser.: 0000000000 IMEI: 00000000-000000-0 EUICCID: 00000000000000000000 HW/SW: 000.000.000 / 000.000.000 peiker acustic GmbH P.O. Box 1446, D-61365 Friedrichsdorf Assembled in Germany 14VDC / 1A</p> <p>FCC ID QWY-ATM2-R11 </p> <p>IFT: xxxxxx</p>
<p>BMW 1D 8706770 01 84.10 10/07/17 550760-10 </p> <p>Model: ATM-02-MEX-T1 Ser.: 1000072455 IMEI: 35681505-000121-4 EUICCID: 89314404000078555159 HW/SW: 202.00X.00X / 001.0XX.0XX peiker acustic GmbH P.O.Box 1446, D-61365 Friedrichsdorf Assembled in Germany 14VDC / 1A</p>			<p>BMW 1D 1 234 567 01 84.10 00/00/00 550760-10 </p> <p>Model: ATM-02-MEX-T1 Ser.: 0000000000 IMEI: 00000000-000000-0 EUICCID: 00000000000000000000 HW/SW: 000.000.000 / 000.000.000 peiker acustic GmbH P.O. Box 1446, D-61365 Friedrichsdorf Assembled in Germany 14VDC / 1A</p> <p>FCC ID QWY-ATM2-T11 </p> <p>IFT: xxxxxx</p>

3.2. Size of the label elements

The label size is 43mm x 66mm.

Part number: 1050-664-005-52

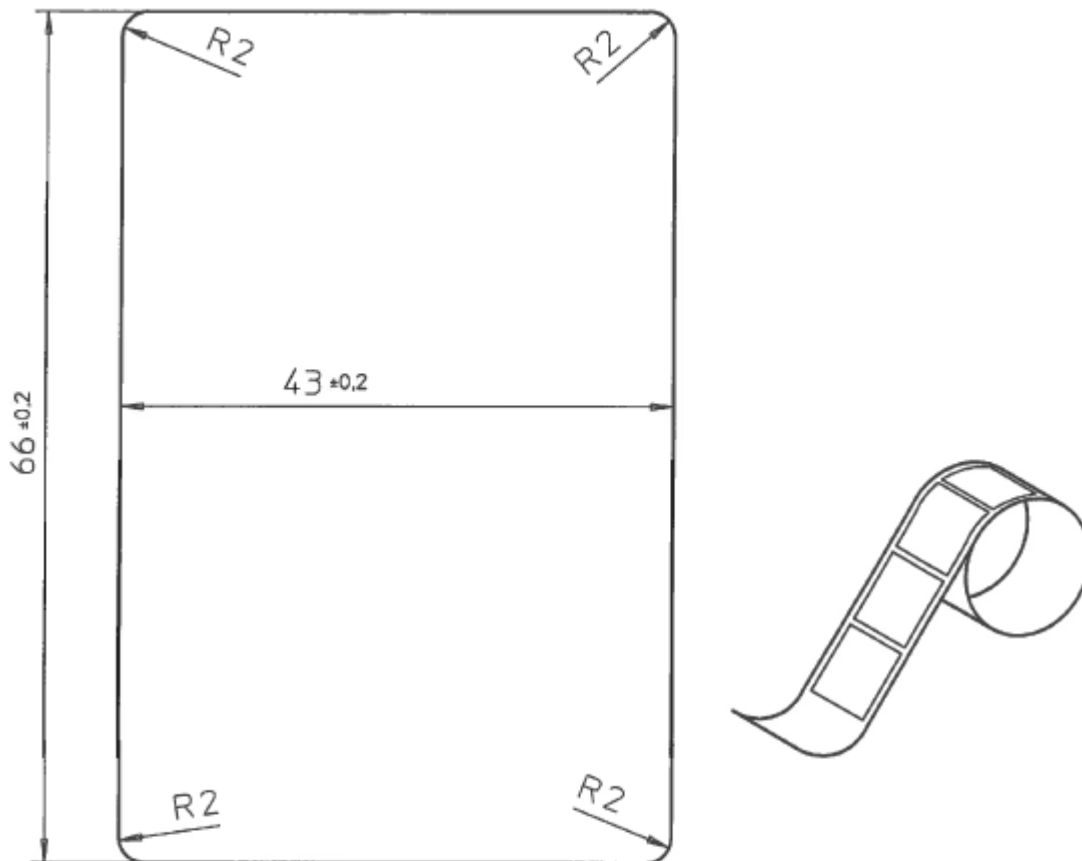

Material	: Wälco KB004455 Polymatic 75(Polyesterfolie)
Farbe	: weiss, Oberflaeche matt
Klebstoff	: permanent haftender Kleber auf Acrylatbasis
Dicke	: 100 um incl. Klebstoff
Traegerpapier	: Glassine, einseitig silikonisiert
Bedruckbarkeit	: Thermotransfer
Lagerdauer	: 2 Jahre
Bestaendigkeit	: gegen Fette und Oele
Klebkraft min.	: Glas und Stahl: > 16N/25mm
Reissfestigkeit	: nach DIN 50014; 50-60N
Temperaturbestaendigkeit	: -40° - +150°
Lieferform	: einbahrig auf Rolle, Rollen kern 76mm

3.3. Position of the label on the device

3.3.1. ATM-02-XXX-R1

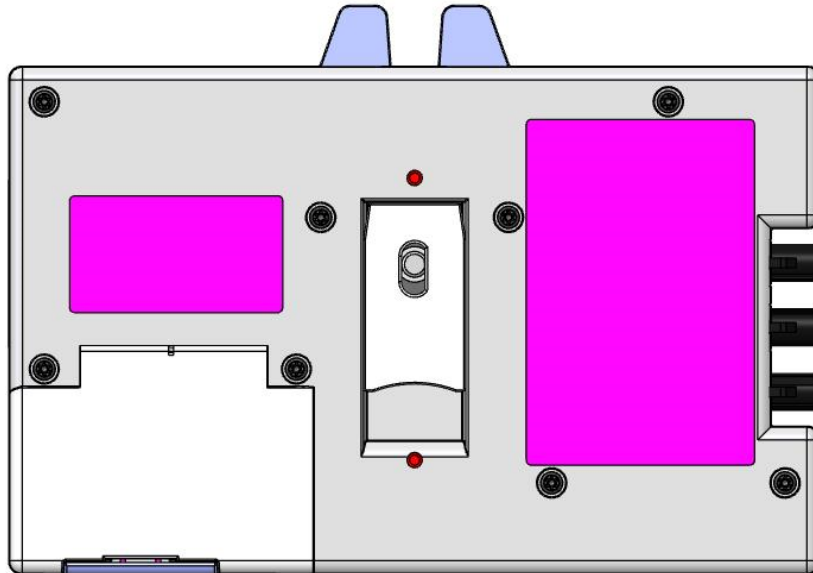

3.3.2. ATM-02-XXX-T1

