

**CETECOM™**

**CETECOM ICT Services**  
consulting - testing - certification >>>

## TEST REPORT

Test report no.: 1-8297/14-02-09-B



Deutsche  
Akkreditierungsstelle  
D-PL-12076-01-00

### Testing laboratory

**CETECOM ICT Services GmbH**

Untertuerkheimer Strasse 6 – 10

66117 Saarbruecken / Germany

Phone: + 49 681 5 98 - 0

Fax: + 49 681 5 98 - 9075

Internet: <http://www.cetecom.com>

e-mail: [ict@cetecom.com](mailto:ict@cetecom.com)

**Accredited Testing Laboratory:**

The testing laboratory (area of testing) is accredited according to DIN EN ISO/IEC 17025 (2005) by the Deutsche Akkreditierungsstelle GmbH (DAkkS)

The accreditation is valid for the scope of testing procedures as stated in the accreditation certificate with the registration number: D-PL-12076-01-00

### Applicant

**peiker acustic GmbH & Co. KG**

Max-Planck Str. 28-32

61381 Friedrichsdorf / GERMANY

Phone: -/-

Fax: +49 6172 767-220

Contact: Martin Fleckenstein

e-mail: [martin.fleckenstein@peiker.de](mailto:martin.fleckenstein@peiker.de)

Phone: +49 6172 767-1379

### Manufacturer

**peiker acustic GmbH & Co. KG**

Max-Planck Str. 28-32

61381 Friedrichsdorf / GERMANY

### Test standard/s

47 CFR Part 22

Title 47 of the Code of Federal Regulations; Chapter I; Part 22 - Public mobile services

RSS - 132 Issue 3

Spectrum Management and Telecommunications Radio Standards Specification - Cellular Telephone Systems Operating in the Bands 824-849 MHz and 869-894 MHz

For further applied test standards please refer to section 3 of this test report.

### Test Item

**Kind of test item:** Advanced Telecommunication module (ATM) Roof Version

**Model name:** ATM-01 R1-US-4GW

**FCC ID:** QWY-ATM-R-522

**IC:** 6588A-ATMR522

**Frequency:** LTE FDD 5: 824 MHz – 849 MHz

**Technology tested:** LTE

**Antenna:** External antenna

**Power supply:** 14.0 V DC by external power supply

**Temperature range:** -30°C to +60°C



This test report is electronically signed and valid without handwriting signature. For verification of the electronic signatures, the public keys can be requested at the testing laboratory.

### Test report authorised:

p.o.

Andreas Luckenbill  
Radio Communications & EMC

### Test performed:

Marco Bertolino  
Radio Communications & EMC

**1 Table of contents**

1 Table of contents .....2

2 General information .....3

    2.1 Notes and disclaimer .....3

    2.2 Application details.....3

3 Test standard/s .....3

4 Test environment.....4

5 Test item .....4

    5.1 Additional information .....4

6 Test laboratories sub-contracted .....4

7 Summary of measurement results .....5

    7.1 LTE band V .....5

8 RF measurements .....6

    8.1 Description of test setup .....6

        8.1.1 Radiated measurements .....6

        8.1.2 Conducted measurements.....7

    8.2 Results LTE band V .....8

        8.2.1 RF output power .....8

        8.2.2 Spurious emissions radiated .....11

        8.2.3 Block edge compliance .....18

9 Test equipment and ancillaries used for tests .....27

10 Observations .....27

Annex A Document history .....28

Annex B Further information.....28

Annex C Accreditation Certificate .....29

## 2 General information

### 2.1 Notes and disclaimer

The test results of this test report relate exclusively to the test item specified in this test report. CETECOM ICT Services GmbH does not assume responsibility for any conclusions and generalizations drawn from the test results with regard to other specimens or samples of the type of the equipment represented by the test item.

The test report may only be reproduced or published in full. Reproduction or publication of extracts from the report requires the prior written approval of CETECOM ICT Services GmbH.

The testing service provided by CETECOM ICT Services GmbH has been rendered under the current "General Terms and Conditions for CETECOM ICT Services GmbH".

CETECOM ICT Services GmbH will not be liable for any loss or damage resulting from false, inaccurate, inappropriate or incomplete product information provided by the customer.

Under no circumstances does the CETECOM ICT Services GmbH test report include any endorsement or warranty regarding the functionality, quality or performance of any other product or service provided.

Under no circumstances does the CETECOM ICT Services GmbH test report include or imply any product or service warranties from CETECOM ICT Services GmbH, including, without limitation, any implied warranties of merchantability, fitness for purpose, or non-infringement, all of which are expressly disclaimed by CETECOM ICT Services GmbH.

All rights and remedies regarding vendor's products and services for which CETECOM ICT Services GmbH has prepared this test report shall be provided by the party offering such products or services and not by CETECOM ICT Services GmbH.

In no case this test report can be considered as a Letter of Approval.

This test report is electronically signed and valid without handwritten signature. For verification of the electronic signatures, the public keys can be requested at the testing laboratory.

### 2.2 Application details

Date of receipt of order:	2014-12-19
Date of receipt of test item:	2015-02-17
Start of test:	2015-02-27
End of test:	2015-03-02
Person(s) present during the test:	-/-

## 3 Test standard/s

Test standard	Date	Test standard description
47 CFR Part 22	-/-	Title 47 of the Code of Federal Regulations; Chapter I; Part 22 - Public mobile services
RSS - 132 Issue 3	01.01.2013	Spectrum Management and Telecommunications Radio Standards Specification - Cellular Telephone Systems Operating in the Bands 824-849 MHz and 869-894 MHz

## 4 Test environment

Temperature:	$T_{nom}$	+22 °C during room temperature tests
	$T_{max}$	+60 °C during high temperature tests
	$T_{min}$	-30 °C during low temperature tests
Relative humidity content:		42 %
Barometric pressure:		not relevant for this kind of testing
Power supply:	$V_{nom}$	14.0 V DC by external power supply
	$V_{max}$	18.0 V
	$V_{min}$	4.5 V

## 5 Test item

<b>Kind of test item</b>	:	Advanced Telecommunication module (ATM) Roof Version
<b>HVIN</b>	:	ATM-01 R1-US-4GW
<b>PMN</b>	:	ATM roof version
<b>S/N serial number</b>	:	Radiated / conducted unit: 0000506765
<b>HW hardware status</b>	:	112.010.016
<b>SW software status</b>	:	001.017.047
<b>Frequency band</b>	:	LTE FDD 5: 824 MHz – 849 MHz
<b>Type of modulation</b>	:	QPSK, 16-QAM
<b>Antenna</b>	:	External antenna
<b>Power supply</b>	:	14.0 V DC by external power supply
<b>Temperature range</b>	:	-30°C to +60°C

### 5.1 Additional information

The content of the following annexes is defined in the QA. It may be that not all of the listed annexes are necessary for this report, thus some values in between may be missing.

Test setup- and EUT-photos are included in test report:      1-8297/14-02-01\_AnnexA  
    1-8297/14-02-01\_AnnexB  
    1-8297/14-02-01\_AnnexC

## 6 Test laboratories sub-contracted

None

## 7 Summary of measurement results

	No deviations from the technical specifications were ascertained
	There were deviations from the technical specifications ascertained
X	This test report is only a partial test report. The content and verdict of the performed test cases are listed below.

TC identifier	Description	verdict	date	Remark
RF-Testing	CFR Part 22 RSS 132	See table!	2015-06-16	Tests according to manufacturer test plan.

### 7.1 LTE band V

Test Case	temperature conditions	power source voltages	Pass	Fail	NA	NP	Remark
RF Output Power	Nominal	Nominal	<input checked="" type="checkbox"/>	<input type="checkbox"/>	<input type="checkbox"/>	<input type="checkbox"/>	complies
Frequency Stability	Nominal	Nominal	<input type="checkbox"/>	<input type="checkbox"/>	<input type="checkbox"/>	<input checked="" type="checkbox"/>	-/-
Spurious Emissions Radiated	Nominal	Nominal	<input checked="" type="checkbox"/>	<input type="checkbox"/>	<input type="checkbox"/>	<input type="checkbox"/>	complies
Spurious Emissions Conducted	Nominal	Nominal	<input type="checkbox"/>	<input type="checkbox"/>	<input type="checkbox"/>	<input checked="" type="checkbox"/>	-/-
Block Edge Compliance	Nominal	Nominal	<input checked="" type="checkbox"/>	<input type="checkbox"/>	<input type="checkbox"/>	<input type="checkbox"/>	complies
Occupied Bandwidth	Nominal	Nominal	<input type="checkbox"/>	<input type="checkbox"/>	<input type="checkbox"/>	<input checked="" type="checkbox"/>	-/-

**Note:** NA = Not applicable; NP = Not performed

## 8 RF measurements

### 8.1 Description of test setup

For the spurious measurements we use the substitution method according TIA/EIA 603.

#### 8.1.1 Radiated measurements

The radiated emissions from the EUT are performed in a semi anechoic chamber. The EUT is placed on a conductive turntable and powered with nominal voltage. The signalling is performed either from outside the chamber with a signalling unit (AP or other) by air link using a signalling antenna or directly by special test software from the customer.

Semi anechoic chamber

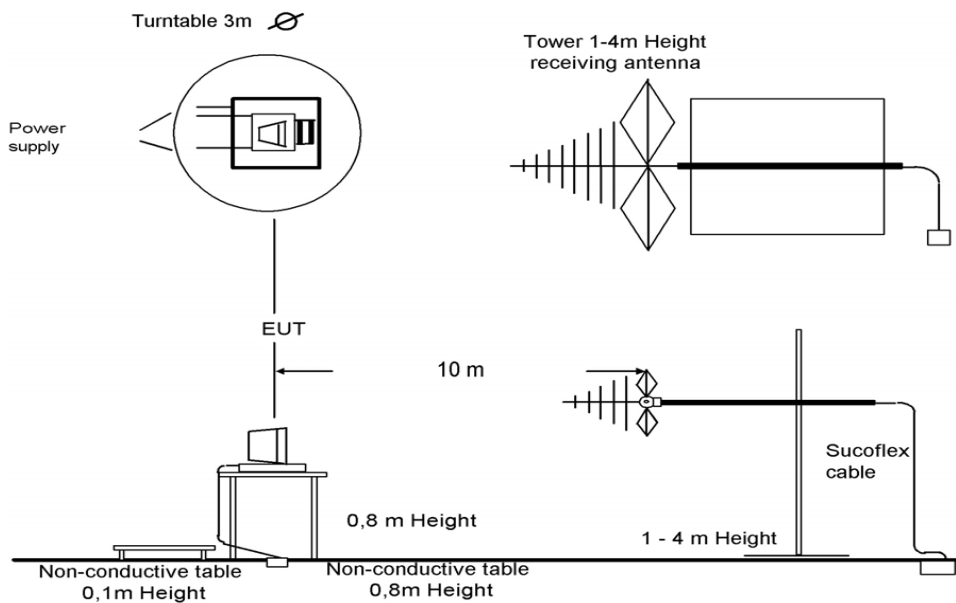

Picture 1: Diagram radiated measurements

9 kHz - 30 MHz:	active loop antenna
30 MHz – 1 GHz:	tri-log antenna
> 1 GHz:	horn antenna

Frequency being measured f	Measuring receiver bandwidth 6 dB	Spectrum analyser bandwidth 3dB
$f < 150 \text{ kHz}$	200 Hz or	300 Hz
$150 \text{ kHz} \leq f < 25 \text{ MHz}$	9 kHz or	10 kHz
$25 \text{ MHz} \leq f < 1000 \text{ MHz}$	120 kHz or	100 kHz
$1000 \text{ MHz} \leq f$		1 MHz

NOTE: Specific requirements in CEPT/ERC/Recommendation 70-03 [2] shall be applied where applicable.

### 8.1.2 Conducted measurements

The EUT's RF signal is coupled out by the antenna connector which is supplied by the manufacturer. The signal is first 10dB attenuated before it is power divided (~6dB loss per branch). One of the signal paths is connected to the signalling unit (AP or other), the other one is connected to the spectrum analyzer. The specific losses for both signal paths are first checked within a calibration. The measurement readings on the signalling unit/spectrum analyzer are corrected by the specific test set-up loss. The attenuator, power divider, signalling unit and the spectrum analyzer are impedance matched on 50 Ohm. If special software is used, there is no power divider necessary.

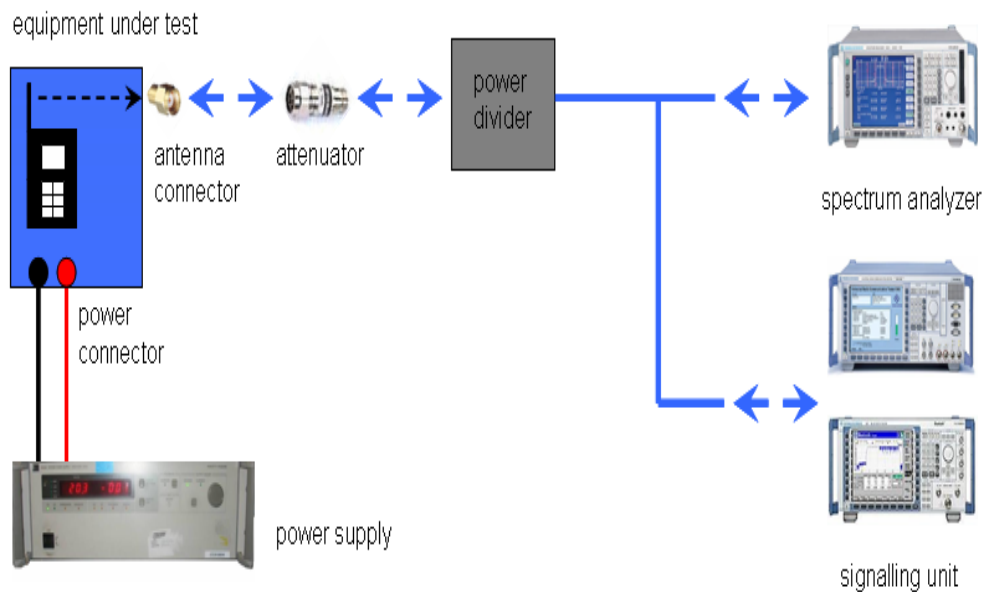

Picture 2: Diagram conducted measurements

The term measuring receiver refers to either a selective voltmeter or a spectrum analyser.

Frequency being measured $f$	Measuring receiver bandwidth 6 dB	Spectrum analyser bandwidth 3dB
$f < 150 \text{ kHz}$	200 Hz or	300 Hz
$150 \text{ kHz} \leq f < 25 \text{ MHz}$	9 kHz or	10 kHz
$25 \text{ MHz} \leq f < 1000 \text{ MHz}$	120 kHz or	100 kHz
$1000 \text{ MHz} \leq f$		1 MHz

NOTE: Specific requirements in CEPT/ERC/Recommendation 70-03 [2] shall be applied where applicable.

## 8.2 Results LTE band V

The EUT was set to transmit the maximum power.

### 8.2.1 RF output power

**Description:**

This paragraph contains average power, peak output power and ERP measurements for the mobile station. In all cases, the peak output power is within the required mask (this mask is specified in the JTC standards, TIA PN3389 Vol. 1 Chap 7, and is no FCC requirement).

**Measurement:**

The mobile was set up for the maximum output power with pseudo random data modulation.

To determine the Peak-To-Average Power Ratio (PAPR) the measurement was performed with the Power Complementary Cumulative Distribution Function (CCDF).

Measurement parameters
Measured with CMW500

**Limits:**

FCC	IC
CFR Part 22.913 CFR Part 2.1046	RSS 132
Nominal Peak Output Power	
+38.45 dBm In measuring transmissions in this band using an average power technique, the peak-to-average ratio (PAR) of the transmission may not exceed 13 dB.	

Used setup acc. chapter 8.1.2.  
Used equipment see table chapter 9



**Results:**

Output Power (conducted)						
Bandwidth (MHz)	Frequency (MHz)	Resource block allocation	Average Output Power (dBm) QPSK	Peak to Average Ratio (dB)	Average Output Power (dBm) 16-QAM	Peak to Average Ratio (dB)
1.4	824.7	1 RB low	22.8	5.63	22.0	6.22
		1 RB high	22.8	5.54	22.0	6.15
		50% RB mid	22.7	5.26	21.8	6.91
		100% RB	21.9	6.18	20.7	7.13
	836.5	1 RB low	22.5	6.55	21.4	5.07
		1 RB high	22.4	6.57	21.4	5.12
		50% RB mid	22.5	7.39	21.6	6.23
		100% RB	21.6	7.29	20.7	7.56
	848.3	1 RB low	22.7	5.05	21.3	6.31
		1 RB high	22.7	5.07	21.3	6.28
		50% RB mid	22.7	6.15	21.9	6.93
		100% RB	21.8	6.63	21.0	6.88
3	825.5	1 RB low	22.8	6.15	22.0	5.55
		1 RB high	22.7	5.99	22.0	5.39
		50% RB mid	21.7	7.08	20.6	6.13
		100% RB	21.7	6.63	20.8	5.92
	836.5	1 RB low	22.4	5.21	21.1	6.42
		1 RB high	22.5	5.27	21.1	6.51
		50% RB mid	21.6	6.99	20.8	7.05
		100% RB	21.5	6.75	20.5	7.40
	847.5	1 RB low	22.8	6.81	21.5	5.29
		1 RB high	22.6	6.88	21.3	5.20
		50% RB mid	21.8	7.04	21.0	6.46
		100% RB	21.9	7.08	21.0	6.41
5	826.5	1 RB low	22.7	5.61	21.8	5.29
		1 RB high	22.6	5.48	21.7	5.23
		50% RB mid	21.7	6.33	20.8	6.85
		100% RB	21.6	6.40	20.7	7.31
	836.5	1 RB low	22.5	6.61	21.3	5.49
		1 RB high	22.7	6.68	21.5	5.57
		50% RB mid	21.5	7.36	20.6	6.70
		100% RB	21.4	8.08	20.5	6.35
	846.5	1 RB low	22.8	5.14	21.6	6.75
		1 RB high	22.8	5.05	21.6	6.61
		50% RB mid	21.9	6.30	21.0	7.20
		100% RB	21.7	6.11	20.9	7.33

10	829	1 RB low	22.7	6.18	21.9	5.55
		1 RB high	22.5	6.43	21.6	5.85
		50% RB mid	21.5	7.36	20.7	6.60
		100% RB	21.5	7.78	20.4	6.52
	836.5	1 RB low	22.4	5.20	21.1	6.40
		1 RB high	22.4	5.31	21.1	6.56
		50% RB mid	21.5	6.92	20.5	8.28
		100% RB	21.4	6.77	20.5	7.67
	844	1 RB low	22.3	7.20	21.1	5.53
		1 RB high	22.6	6.87	21.3	5.23
		50% RB mid	21.7	8.04	20.7	6.53
		100% RB	21.5	7.86	20.6	6.63
Measurement uncertainty		± 0.5 dB				

The radiated output power is measured in the mode with the highest conducted output power.

Output Power (radiated)			
Bandwidth (MHz)	Frequency (MHz)	Average Output Power (dBm)	
		QPSK	16-QAM
1.4	824.7	19.4	18.6
	836.5	18.0	17.1
	848.3	17.1	16.3
3	825.5	19.4	18.6
	836.5	18.0	16.6
	847.5	17.2	15.9
5	826.5	19.3	18.4
	836.5	18.2	17.0
	846.5	17.2	16.0
10	829.0	19.3	18.5
	836.5	17.9	16.6
	844.0	17.0	15.7
Measurement uncertainty		± 3.0 dB	

**Verdict:** [complies](#)

## 8.2.2 Spurious emissions radiated

### Description:

The following steps outline the procedure used to measure the radiated emissions from the mobile station. The site is constructed in accordance with ANSI C63.4:2014 requirements and is recognized by the FCC to be in compliance for a 3 and a 10 meter site. The spectrum was scanned from 9 kHz to the 10th harmonic of the highest frequency generated within the equipment, which is the transmitted carrier that can be as high as 846.6 MHz. Measurements made up to 12.75 GHz. The resolution bandwidth is set as outlined in Part 22.917. The spectrum was scanned with the mobile station transmitting at carrier frequencies that pertain to low, mid and high channels of the LTE band V.

The final open field emission (here 10m semi-anechoic chamber listed by FCC) test procedure is as follows:

- a) The test item was placed on a 0.8 meter high non-conductive stand at a 3 meter test distance from the receive antenna.
- b) The antenna output was terminated in a 50 ohm load (if possible).
- c) A double ridged wave guide antenna was placed on an adjustable height antenna mast 3 meters from the test item for emission measurements.
- d) Detected emissions were maximized at each frequency by rotating the test item and adjusting the receive antenna height and polarization. The maximum meter reading was recorded. The radiated emission measurements of the harmonics of the transmit frequency through the 10th harmonic were measured with peak detector and 1 MHz bandwidth. If the harmonic could not be detected above the noise floor, the ambient level was recorded. The equivalent power into a dipole antenna was calculated from the field intensity levels measured at 3 meters.
- e) Now each detected emissions were substituted by the substitution method, in accordance with the TIA/EIA 603.

### Measurement:

Measurement parameters	
Detector:	Peak
Sweep time:	2 sec.
Video bandwidth:	Below 1 GHz: 100 kHz Above 1 GHz: 1 MHz
Resolution bandwidth:	Below 1 GHz: 100 kHz Above 1 GHz: 1 MHz
Span:	100 MHz Steps
Trace-Mode:	Max Hold

### Limits:

FCC	IC
CFR Part 22.917 CFR Part 2.1053	RSS 132
Spurious Emissions Radiated	
Attenuation $\geq 43 + 10\log(P)$ (P, Power in Watts)	
-13 dBm	

Used setup acc. chapter 8.1.1.  
Used equipment see table chapter 9

**Results:**

Radiated emissions measurements were made only at the center carrier frequency of the LTE band V (836.5 MHz). It was decided that measurements at this carrier frequency would be sufficient to demonstrate compliance with emissions limits because it was seen that all the significant spurs occur well outside the band and no radiation was seen from a carrier in one block of the LTE band V into any of the other blocks. The equipment must still, however, meet emissions requirements with the carrier at all frequencies over which it is capable of operating and it is the manufacturer's responsibility to verify this.

The final open field radiated levels are presented on the next pages. All measurements were done in horizontal and vertical polarization; the plots show the worst case. The plots show only the middle channel. If spurious were detected, the lowest and highest channel were checked too. The found values are stated in the table below.

As can be seen from this data, the emissions from the test item were within the specification limit.

**QPSK:**

Spurious Emission Level (dBm)								
Harmonic	Lowest channel Freq. (MHz)	Level [dBm]	Harmonic	Middle channel Freq. (MHz)	Level [dBm]	Harmonic	Highest channel Freq. (MHz)	Level [dBm]
2	1658.0	-	2	1673.0	-	2	1688.0	-
3	2487.0	-	3	2509.5	-	3	2532.0	-
4	3316.0	-	4	3346.0	-	4	3376.0	-
5	4145.0	-	5	4182.5	-	5	4220.0	-
6	4974.0	-	6	5019.0	-	6	5064.0	-
7	5803.0	-	7	5855.5	-	7	5908.0	-
8	6632.0	-	8	6692.0	-	8	6752.0	-
9	7461.0	-	9	7528.5	-	9	7596.0	-
10	8290.0	-	10	8365.0	-	10	8440.0	-
Measurement uncertainty					± 3dB			

**16-QAM:**

Spurious Emission Level (dBm)								
Harmonic	Lowest channel Freq. (MHz)	Level [dBm]	Harmonic	Middle channel Freq. (MHz)	Level [dBm]	Harmonic	Highest channel Freq. (MHz)	Level [dBm]
2	1658.0	-	2	1673.0	-	2	1688.0	-
3	2487.0	-	3	2509.5	-	3	2532.0	-
4	3316.0	-	4	3346.0	-	4	3376.0	-
5	4145.0	-	5	4182.5	-	5	4220.0	-
6	4974.0	-	6	5019.0	-	6	5064.0	-
7	5803.0	-	7	5855.5	-	7	5908.0	-
8	6632.0	-	8	6692.0	-	8	6752.0	-
9	7461.0	-	9	7528.5	-	9	7596.0	-
10	8290.0	-	10	8365.0	-	10	8440.0	-
Measurement uncertainty					± 3dB			

**Verdict:** [complies](#)

**Plots: QPSK with 10 MHz channel bandwidth**

**Plot 1: Middle channel - 836.5 MHz (Traffic mode up to 30 MHz)**

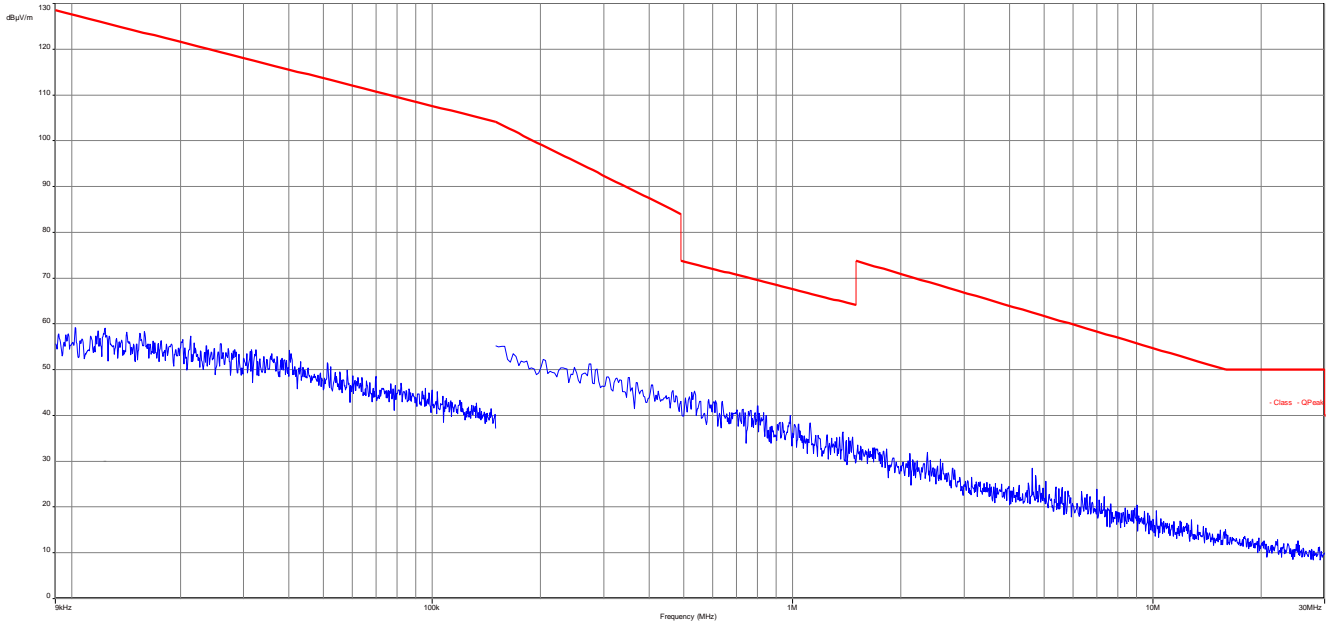

**Plot 2: Lowest channel – 829 MHz (30 MHz – 12.75 GHz)**

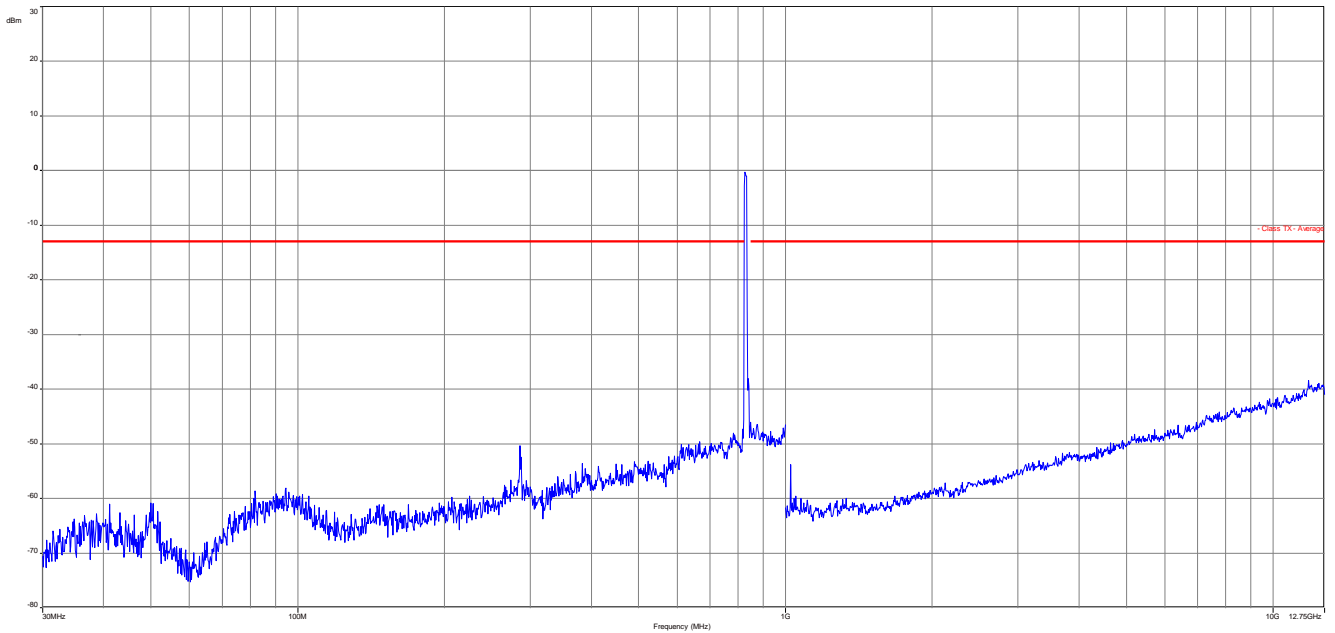

**Plot 3:** Middle channel – 836.5 MHz (30 MHz – 12.75 GHz)

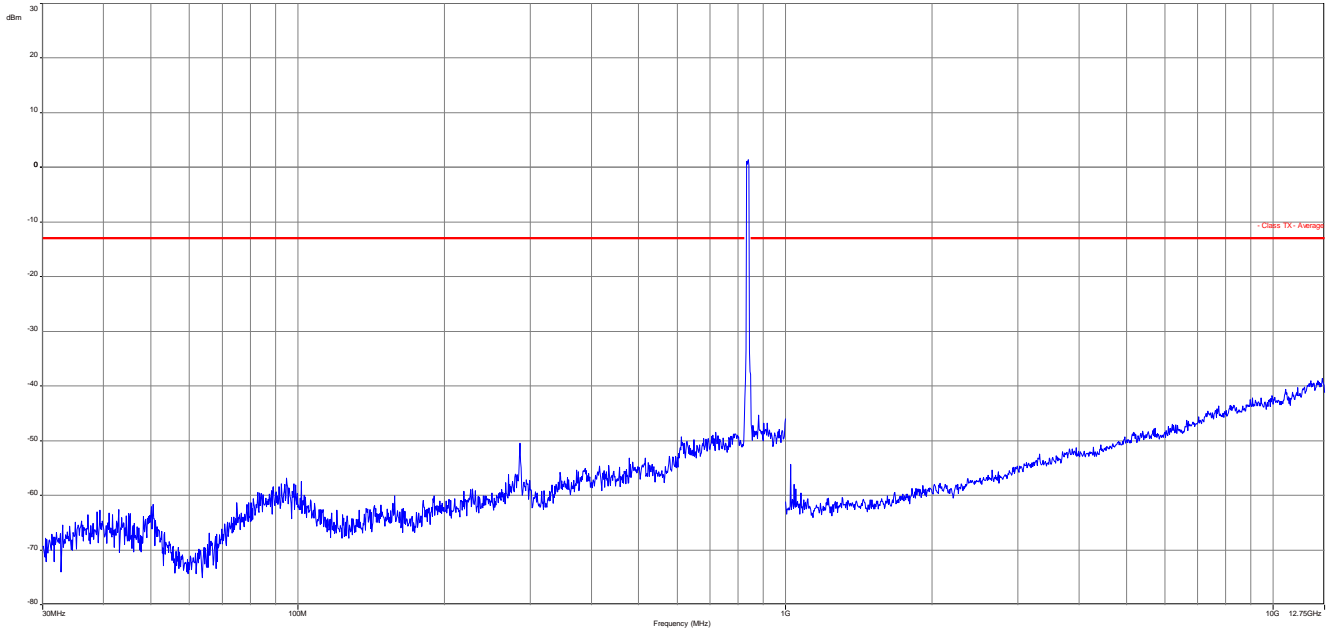

**Plot 4:** Highest channel – 844 MHz (30 MHz – 12.75 GHz)

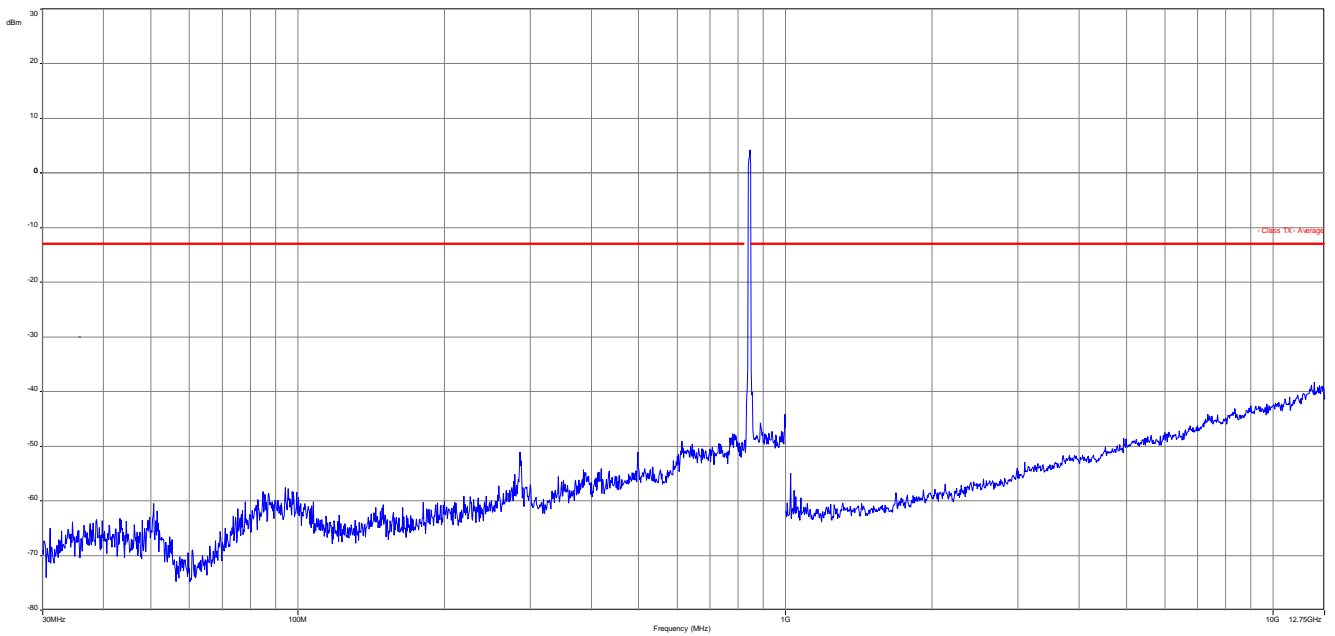

**Plots: 16-QAM with 10 MHz channel bandwidth**

**Plot 1: Middle channel - 836.5 MHz (Traffic mode up to 30 MHz)**

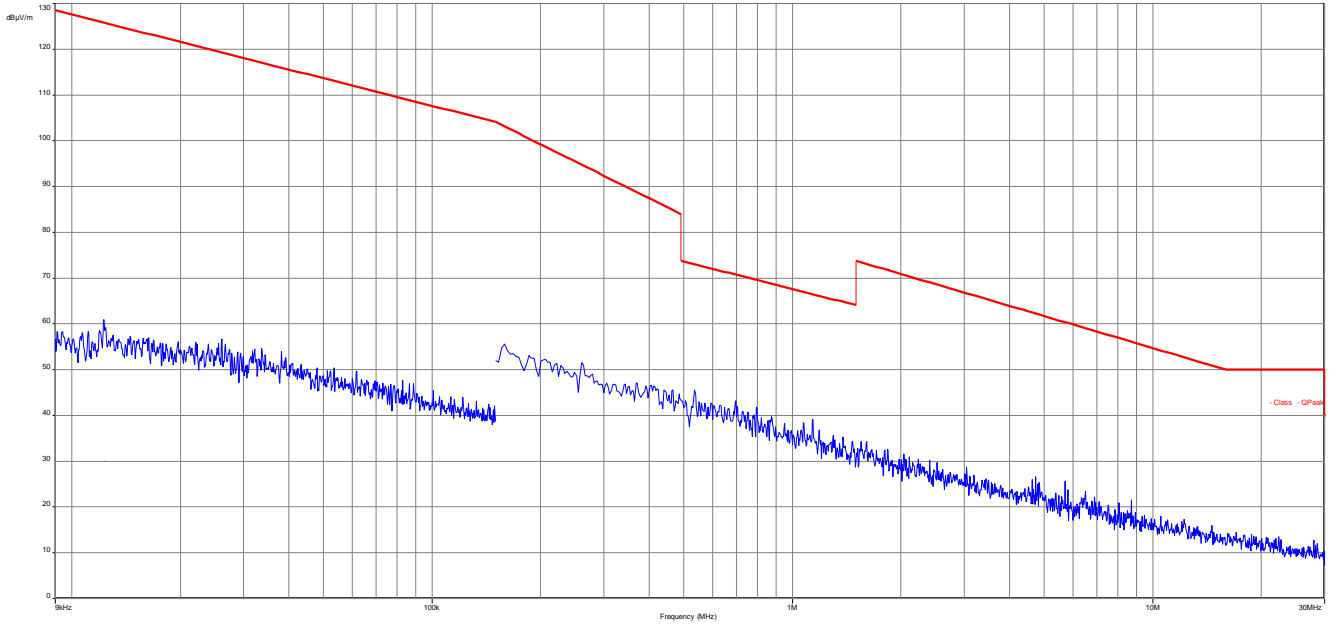

**Plot 2: Lowest channel – 829 MHz (30 MHz – 12.75 GHz)**

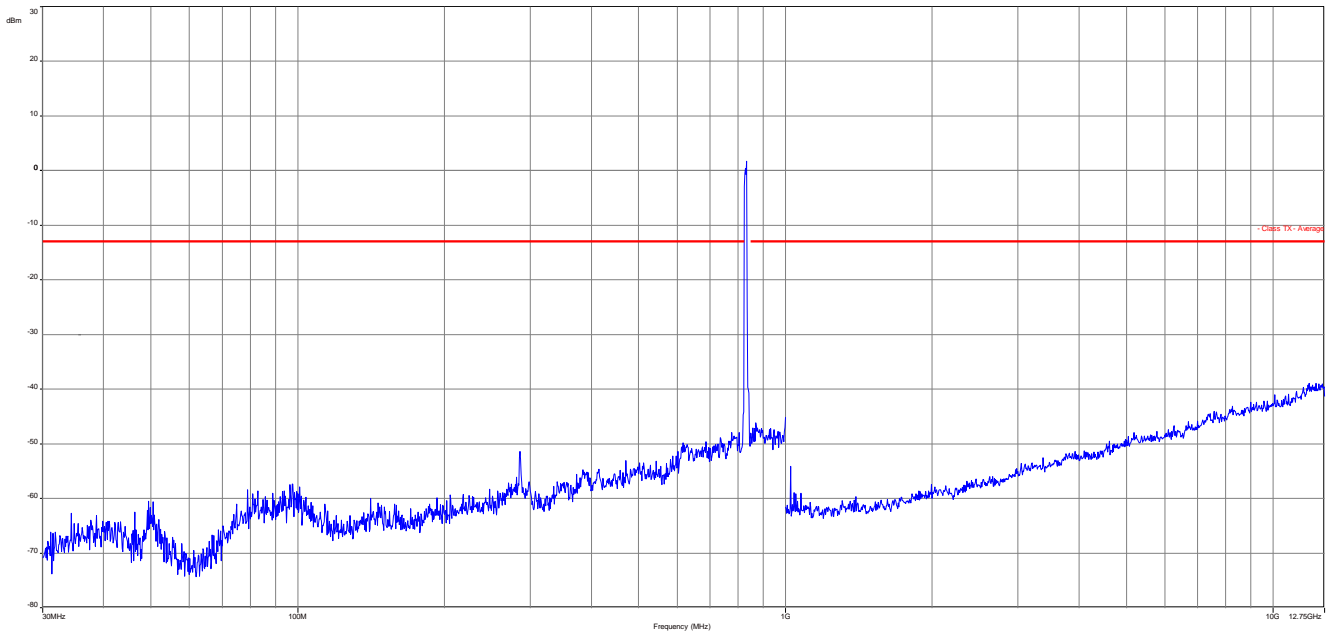



**Plot 3: Middle channel – 836.5 MHz (30 MHz – 12.75 GHz)**

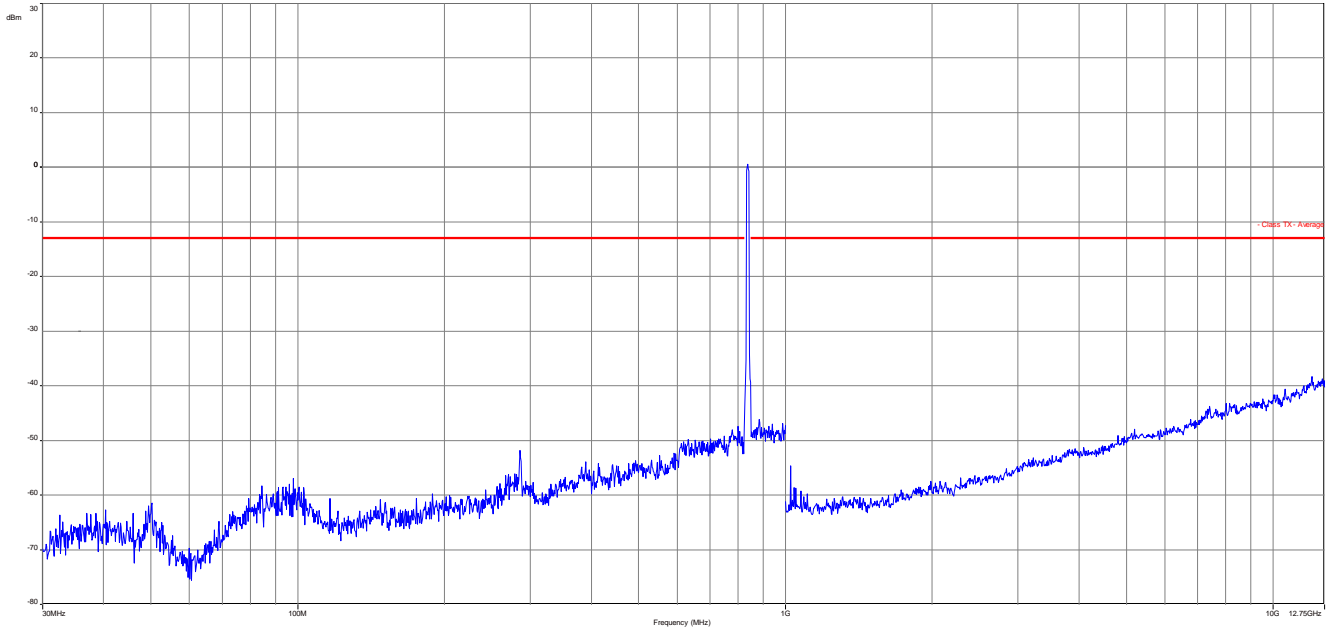

**Plot 4: Highest channel – 844 MHz (30 MHz – 12.75 GHz)**

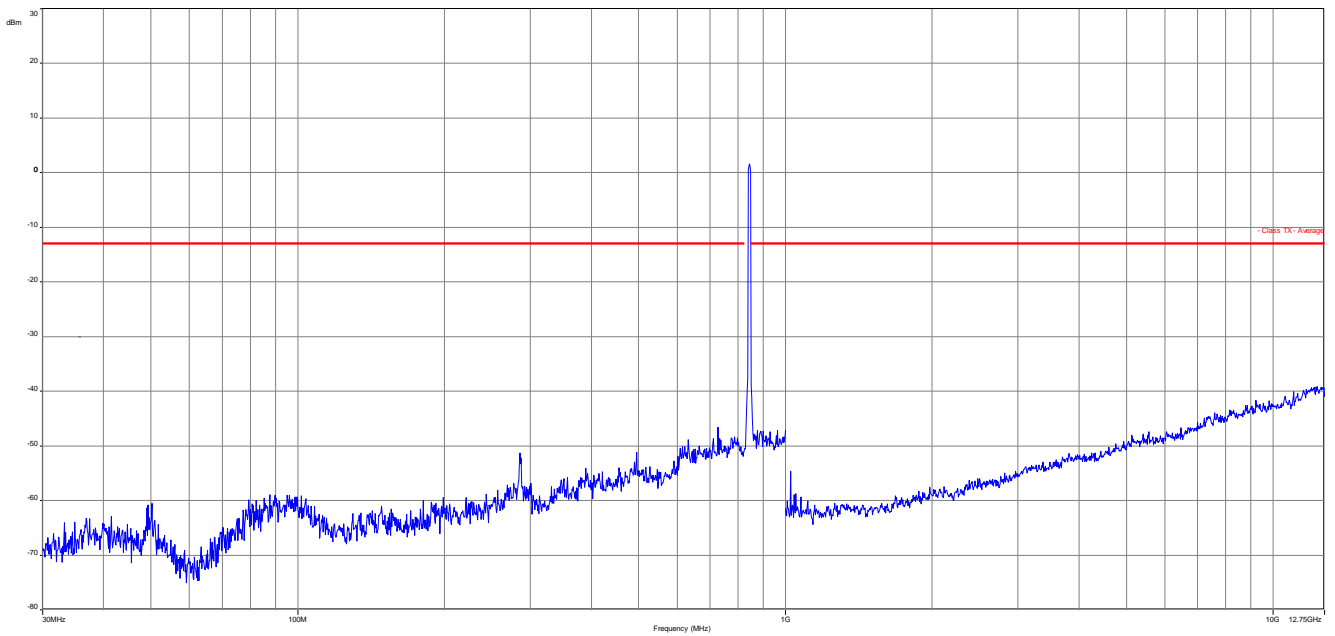

### 8.2.3 Block edge compliance

**Description:**

The spectrum at the band edges must comply with the spurious emissions limits.

**Measurement:**

Measurement parameters	
Detector:	RMS
Sweep time:	60 s
Video bandwidth:	30 kHz
Resolution bandwidth:	30 kHz
Span:	1 MHz
Trace-Mode:	Max Hold

**Limits:**

FCC	IC
CFR Part 22.917 CFR Part 2.1051	RSS 132
Block Edge Compliance	
Part 22.917 specifies that “the power of any emission outside of the authorized operating frequency ranges must be attenuated below the transmitting power (P) by a factor of at least 43 + 10 log(P) dB.”  However, in publication number 890810, The FCC Office of Engineering and Technology specified the following correction to the limits when a resolution bandwidth smaller than 1% of the emission bandwidth is used:  “An alternative is to add an additional correction factor of 10 Log (RBW1/ RBW2) to the 43 +10 log(P) limit. RBW1 is the narrower measurement resolution bandwidth and RBW2 is either the 1% emissions bandwidth or 1 MHz.”  When using a 30 kHz bandwidth, this yields a -5.23 adjustment to the limit [10 log(30kHz/100kHz) = -5.23]. When this adjustment is applied to the limit, the limit becomes -18.23 dBm.	
-18.23 dBm	

The limit line in the plots shows the over all LTE bands and channel bandwidths worst case -21.24 dBm.

Used setup acc. chapter 8.1.2.

Used equipment see table chapter 9

**Results: 1.4 MHz channel bandwidth**

**Plot 1: Lowest channel – QPSK**

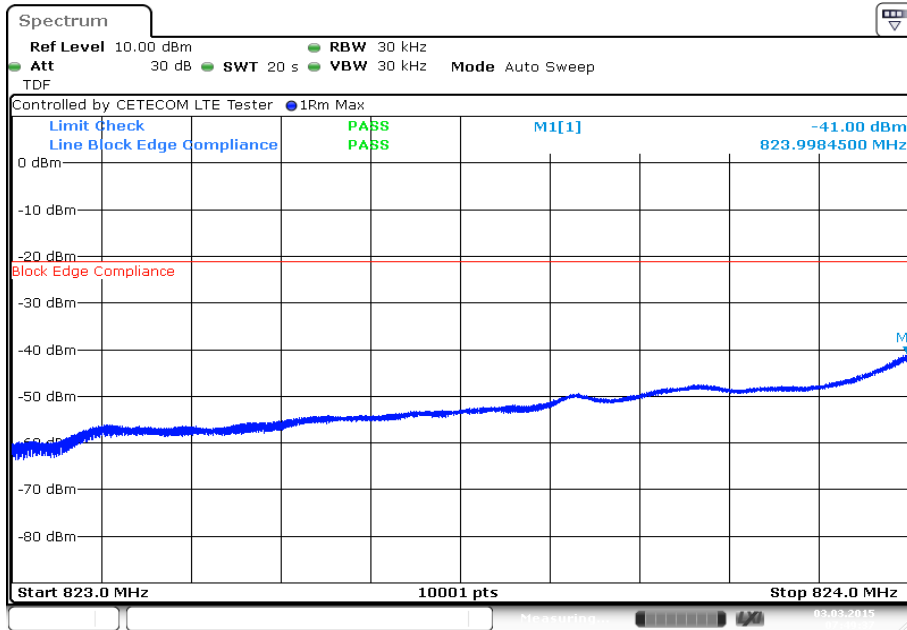

**Plot 2: Highest channel – QPSK**

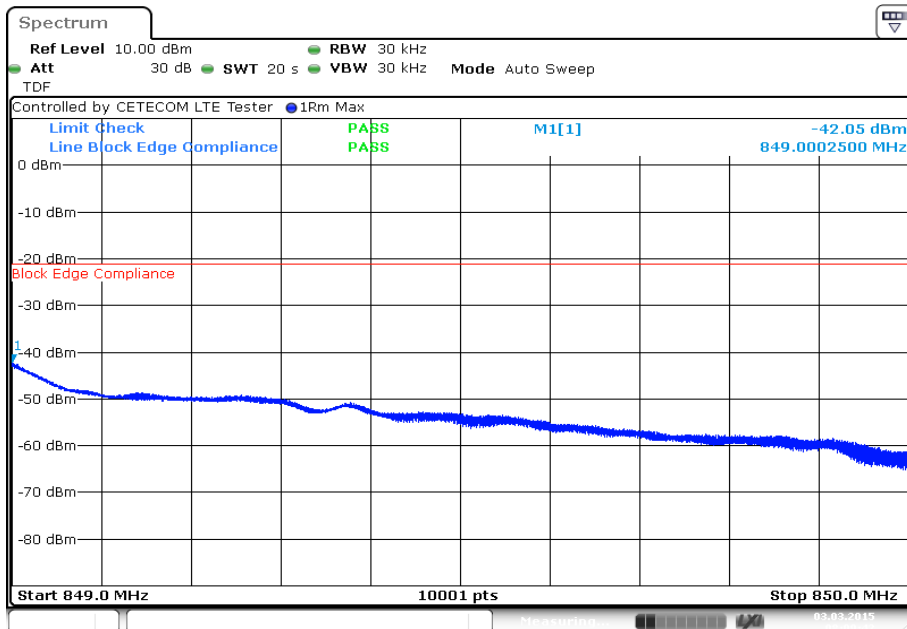

Plot 3: Lowest channel – 16-QAM

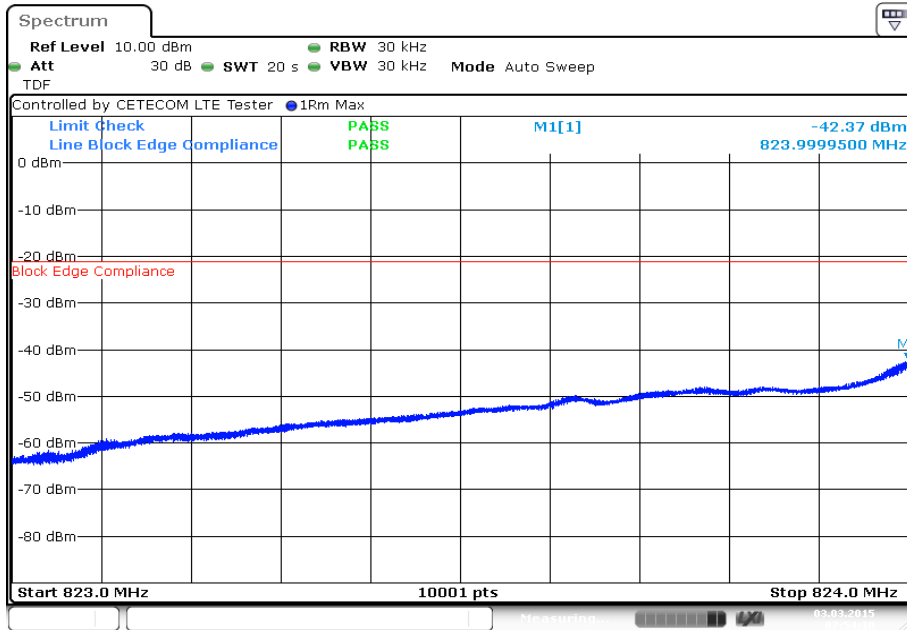

Date: 3.MAR.2015 07:54:11

Plot 4: Highest channel – 16-QAM

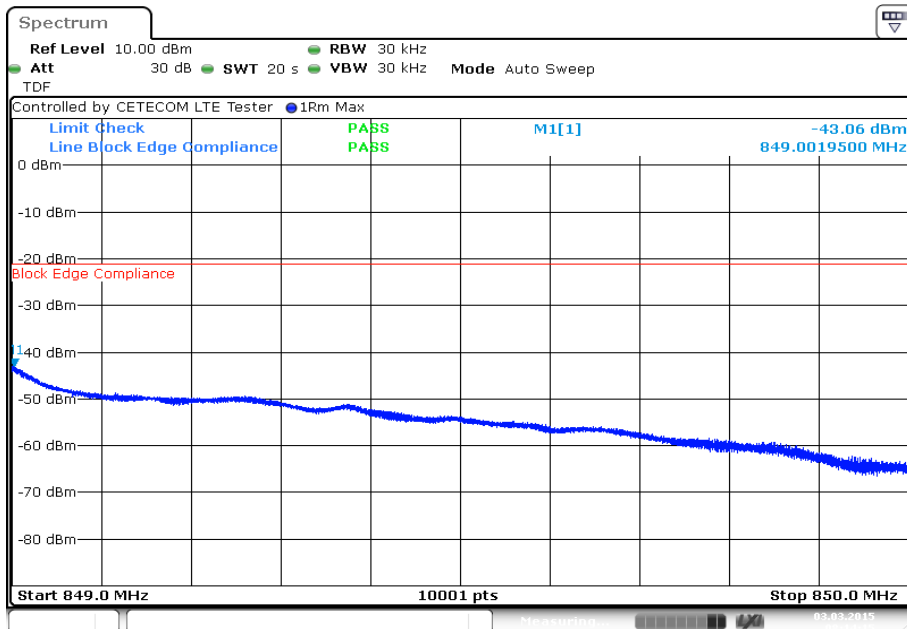

Date: 3.MAR.2015 08:14:16

**Results: 3 MHz channel bandwidth**

**Plot 1: Lowest channel – QPSK**

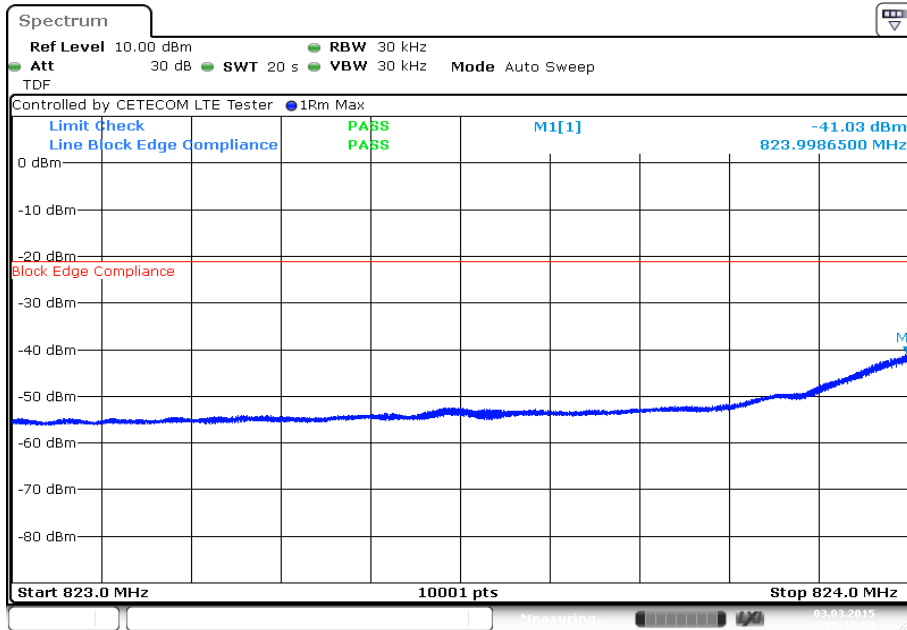

Date: 3.MAR.2015 08:19:05

**Plot 2: Highest channel – QPSK**

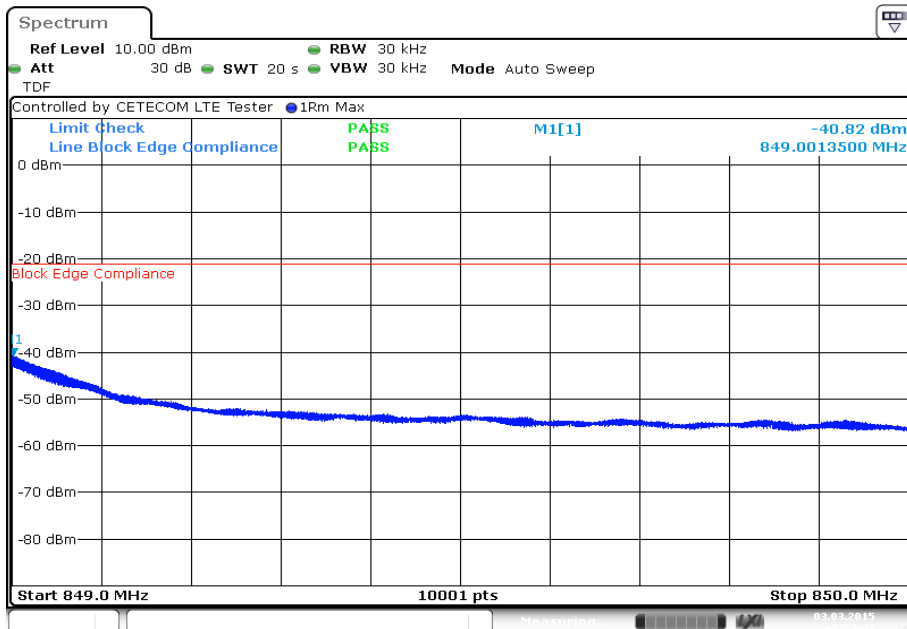

Date: 3.MAR.2015 08:54:42

Plot 3: Lowest channel – 16-QAM

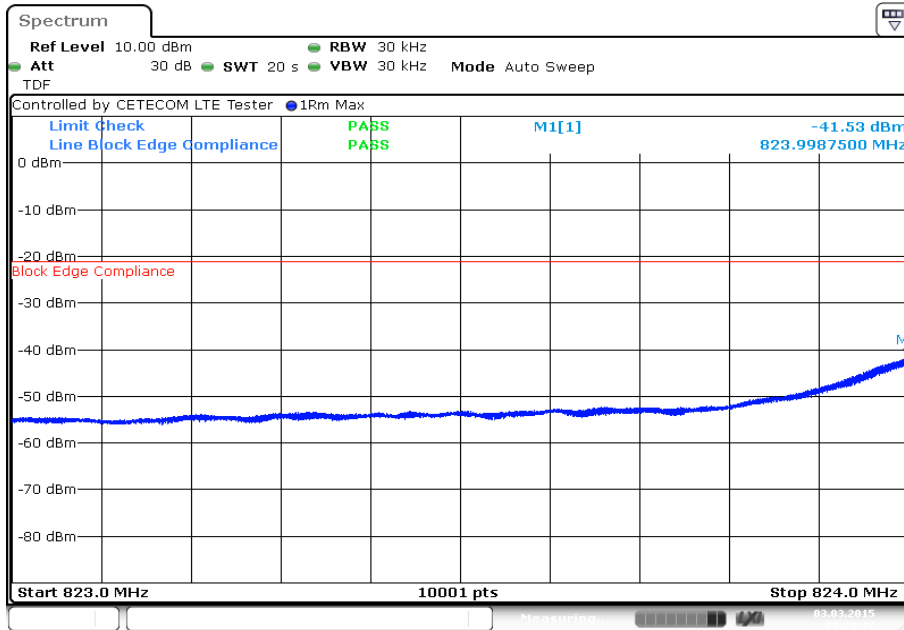

Plot 4: Highest channel – 16-QAM

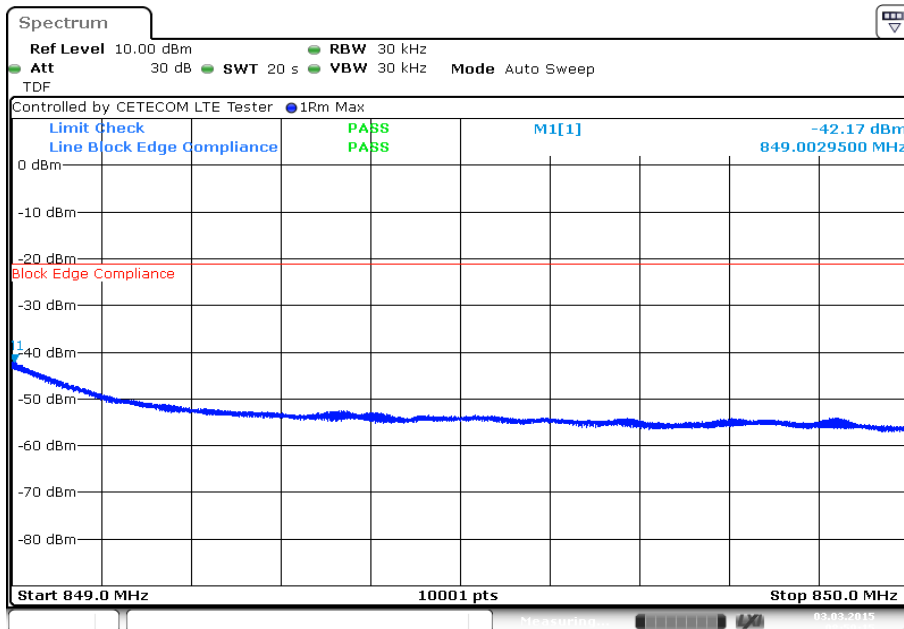

**Results: 5 MHz channel bandwidth**

**Plot 1: Lowest channel – QPSK**

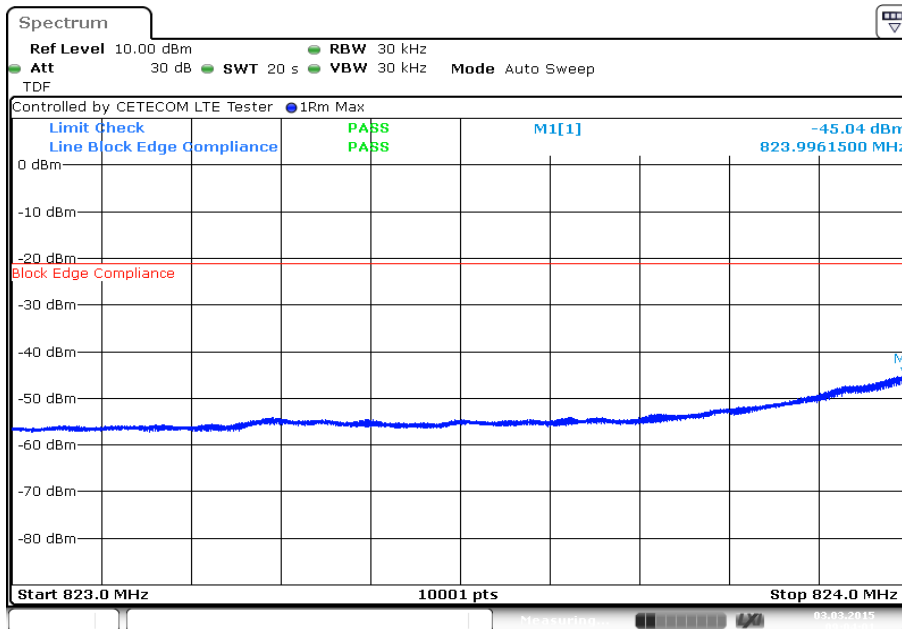

Date: 3.MAR.2015 09:04:02

**Plot 2: Highest channel – QPSK**

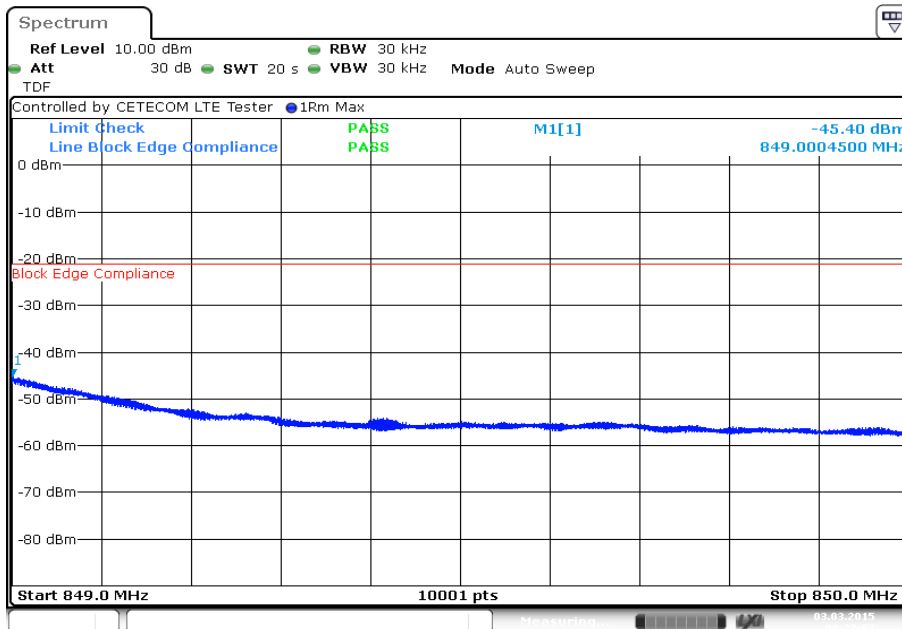

Date: 3.MAR.2015 09:23:02

Plot 3: Lowest channel – 16-QAM

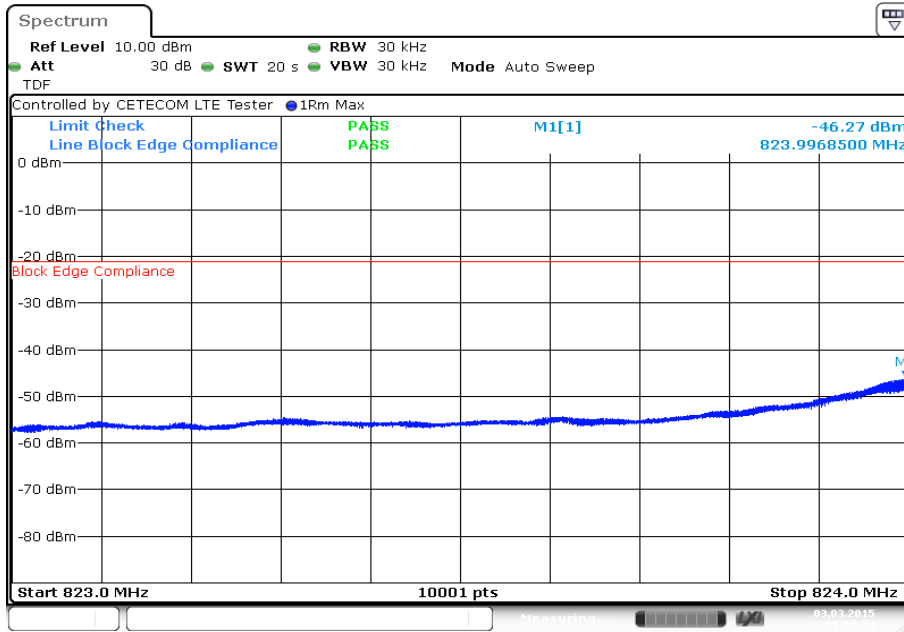

Plot 4: Highest channel – 16-QAM

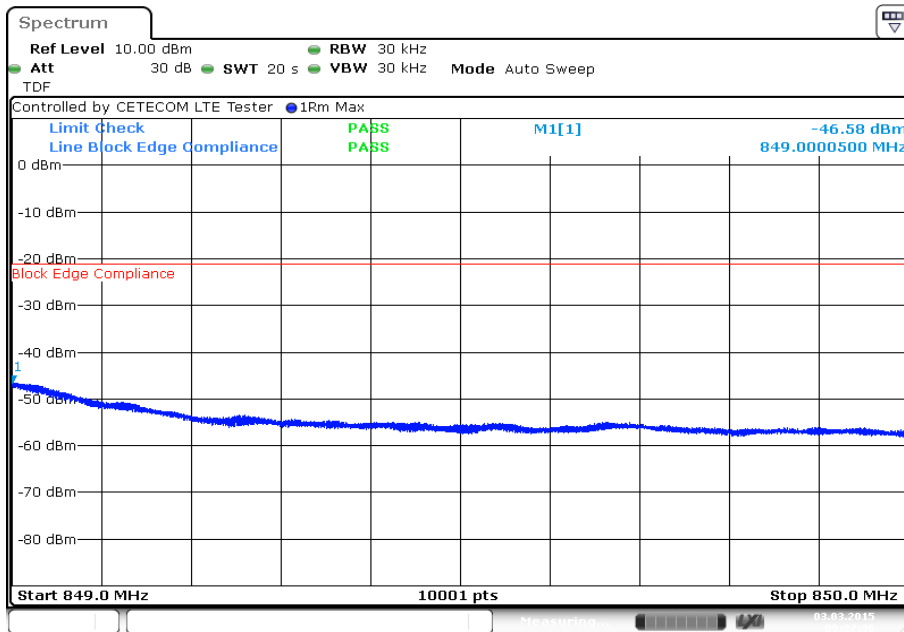



**Results: 10 MHz channel bandwidth**

**Plot 1: Lowest channel – QPSK**

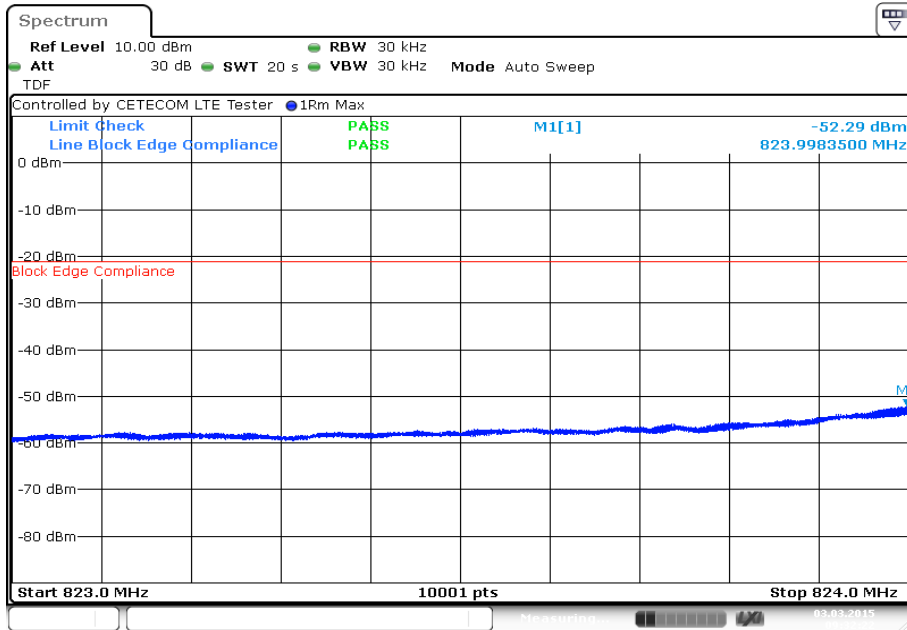

**Plot 2: Highest channel – QPSK**

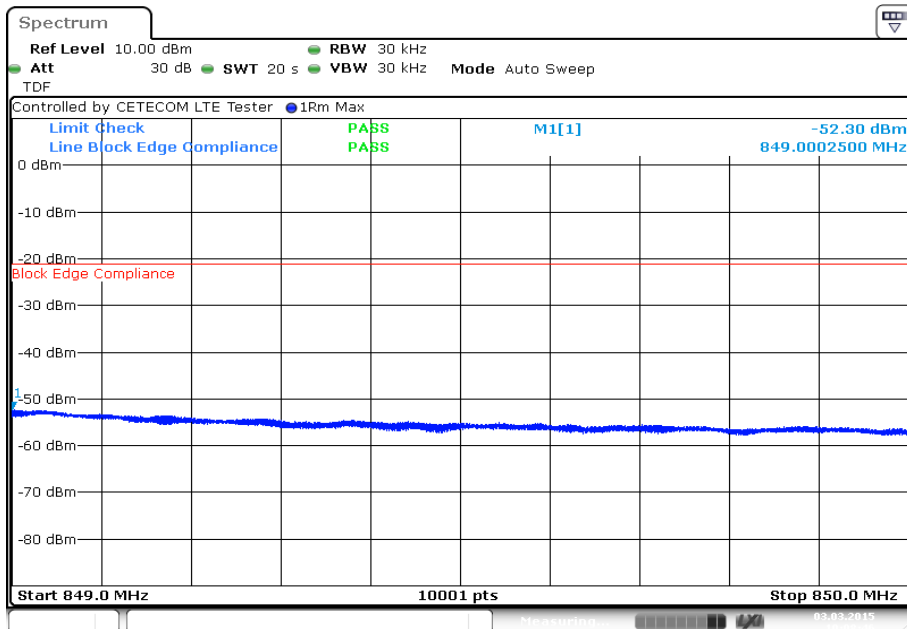

Plot 3: Lowest channel – 16-QAM

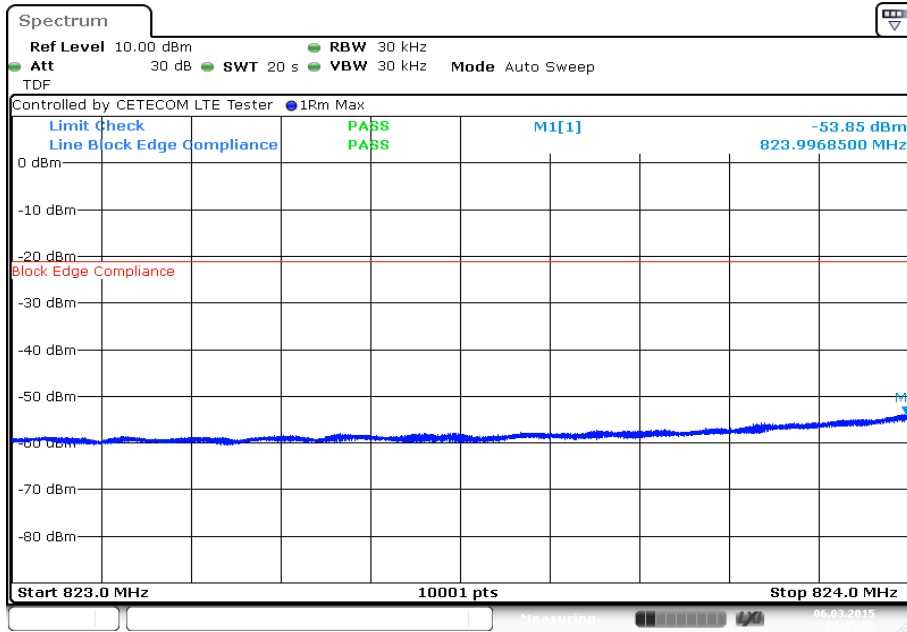

Plot 4: Highest channel – 16-QAM

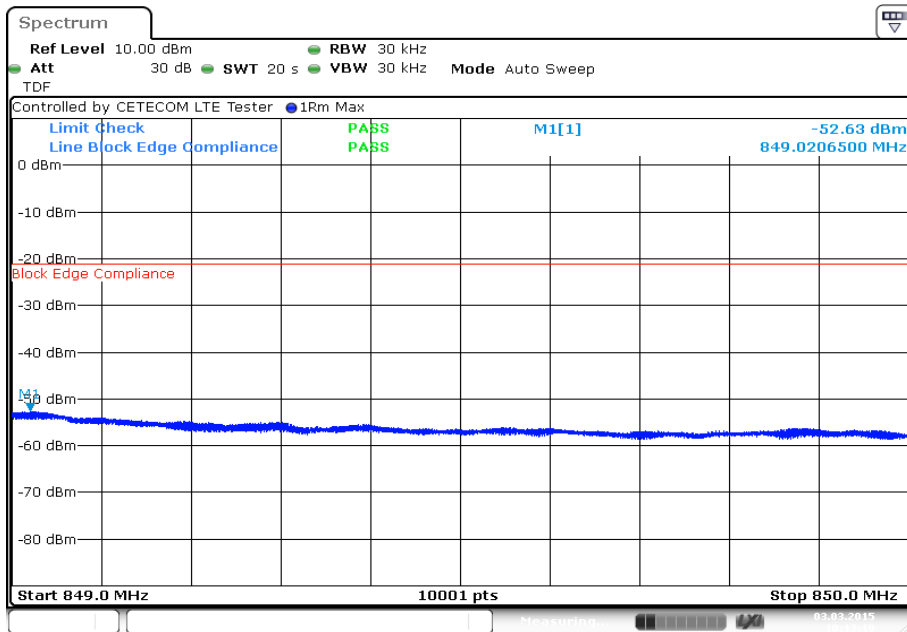

**Verdict: complies**

## 9 Test equipment and ancillaries used for tests

Typically, the calibrations of the test apparatus are commissioned to and performed by an accredited calibration laboratory. The calibration intervals are determined in accordance with the DIN EN ISO/IEC 17025. In addition to the external calibrations, the laboratory executes comparison measurements with other calibrated test systems or effective verifications. Weekly chamber inspections and range calibrations are performed. Where possible, rf-generating and signalling equipment as well as measuring receivers and analyzers are connected to an external high-precision 10 MHz reference (GPS-based or rubidium frequency standard).

In order to simplify the identification of the equipment used at some special tests, some items of test equipment and ancillaries can be provided with an identifier or number in the equipment list below (Lab/Item).

No.	Lab / Item	Equipment	Type	Manufact.	Serial No.	INV. No Cetecom	Kind of Calibration	Last Calibration	Next Calibration
1	n. a.	DC power supply, 60Vdc, 50A, 1200 W	6032A	HP	2818A03450	300001040	Ve	20.01.2015	20.01.2018
2	n. a.	Double-Ridged Waveguide Horn Antenna 1-18.0GHz	3115	EMCO	8812-3088	300001032	vIKI!	08.05.2013	08.05.2015
3	n. a.	Anechoic chamber	FAC 3/5m	MWB / TDK	87400/02	300000996	ev		
4	n. a.	Switch / Control Unit	3488A	HP	*	300000199	ne		
5	90	Active Loop Antenna 10 kHz to 30 MHz	6502	Kontron Psychotech	8905-2342	300000256	k	13.06.2013	13.06.2015
6	90	Amplifier	js42-00502650-28-5a	Parzich GMBH	928979	300003143	ne		
7	90	TRILOG Broadband Test-Antenna 30 MHz - 3 GHz	VULB9163	Schwarzbeck	371	300003854	vIKI!	29.10.2014	29.10.2017
8	90	MXE EMI Receiver 20 Hz to 26,5 GHz	N9038A	Agilent Technologies	MY51210197	300004405	k	13.03.2014	13.03.2015
9	n. a.	Signal Analyzer 40 GHz	FSV40	R&S	101042	300004517	k	22.01.2015	22.01.2016
10	n. a.	Wideband Radio Communication Tester	CMW500	R&S	102375	300004187	k	28.01.2015	28.01.2017

### Agenda: Kind of Calibration

k	calibration / calibrated	EK	limited calibration
ne	not required (k, ev, izw, zw not required)	zw	cyclical maintenance (external cyclical maintenance)
ev	periodic self verification	izw	internal cyclical maintenance
Ve	long-term stability recognized	g	blocked for accredited testing
vIKI!	Attention: extended calibration interval	*)	next calibration ordered / currently in progress
NK!	Attention: not calibrated		

## 10 Observations

No observations except those reported with the single test cases have been made.

**Annex A Document history**

Version	Applied changes	Date of release
	Initial release	2015-03-25
A	New editorial requirements (Canada)	2015-04-28
B	Editorial corrections	2015-06-16

**Annex B Further information****Glossary**

AVG	-	Average
DUT	-	Device under test
EMC	-	Electromagnetic Compatibility
EN	-	European Standard
EUT	-	Equipment under test
ETSI	-	European Telecommunications Standard Institute
FCC	-	Federal Communication Commission
FCC ID	-	Company Identifier at FCC
HW	-	Hardware
IC	-	Industry Canada
Inv. No.	-	Inventory number
N/A	-	Not applicable
PP	-	Positive peak
QP	-	Quasi peak
S/N	-	Serial number
SW	-	Software

## Annex C Accreditation Certificate

Front side of certificate

Back side of certificate



Deutsche Akkreditierungsstelle GmbH

Befehle gemäß § 8 Absatz 1 AkkStelleG i.V.m. § 1 Absatz 1 AkkStelleGBV  
 Unterzeichnerin der Multilateralen Abkommen  
 von EA, ILAC und IAF zur gegenseitigen Anerkennung

### Akkreditierung



Die Deutsche Akkreditierungsstelle GmbH bestätigt hiermit, dass das Prüflaboratorium

**CETECOM ICT Services GmbH**  
 Untertürkheimer Straße 6-10, 66117 Saarbrücken

die Kompetenz nach DIN EN ISO/IEC 17025:2005 besitzt, Prüfungen in folgenden Bereichen durchzuführen:

- Drahtgebundene Kommunikation einschließlich xDSL
- VoIP und DECT
- Akustik
- Funk einschließlich WLAN
- Short Range Devices (SRD)
- RFID
- WiMax und Richtfunk
- Mobilfunk (GSM / GPRS / UTRAN / LTE Performance)
- Elektromagnetische Verträglichkeit (EMV) einschließlich Automotive
- Produktsicherheit
- SAR und Hearing Aid Compatibility (HAC)
- Umweltstimulation
- Smart Card Terminals
- Bluetooth
- Wi-Fi-Services

Die Akkreditierungsurkunde gilt nur in Verbindung mit dem Bescheid vom 07.03.2014 mit der Akkreditierungsnummer D-PL-12076-01 und ist gültig 17.01.2018. Sie besteht aus diesem Deckblatt, der Rückseite des Deckblatts und der folgenden Anlage mit insgesamt 77 Seiten.

Registrierungsnummer der Urkunde: D-PL-12076-01-00

Frankfurt am Main, 07.03.2014  
 Date of issue of the certificate

In Auftrag gegeben von  
 Abteilungsleiter

Deutsche Akkreditierungsstelle GmbH

Standort Berlin Spittelmarkt 10 10117 Berlin	Standort Frankfurt am Main Gartenstraße 6 60594 Frankfurt am Main	Standort Braunschweig Bundesallee 100 38116 Braunschweig
--	---	--

Die auszugsweise Veröffentlichung der Akkreditierungsurkunde bedarf der vorherigen schriftlichen Zustimmung der Deutsche Akkreditierungsstelle GmbH (DAkkS). Ausgenommen davon ist die separate Weiterverbreitung des Deckblattes durch die umseitig genannte Kontaktperson in unveränderter Form.

Es darf nicht der Anschein erweckt werden, dass sich die Akkreditierung auch auf Bereiche erstreckt, die über den durch die DAkkS bestätigten Akkreditierungsbereich hinausgehen.

Die Akkreditierung erfolgt gemäß des Gesetzes über die Akkreditierungsstelle (AkkStelleG) vom 31. Juli 2005 (BGBl. I S. 2625) sowie der Verordnung (EG) Nr. 765/2008 des Europäischen Parlaments und des Rates vom 9. Juli 2008 über die Vorschriften für die Akkreditierung und Marktüberwachung im Zusammenhang mit der Vermarktung von Produkten (Abbl. L 218 vom 9. Juli 2008, S. 30). Die DAkkS ist Unterzeichnerin der Multilateralen Abkommen zur gegenseitigen Anerkennung der Europäischen Organisation für Akkreditierung (EA), des International Accreditation Forum (IAF) und der International Laboratory Accreditation Cooperation (ILAC). Die Unterzeichner dieser Abkommen erkennen ihre Akkreditierungen gegenseitig an.

Der aktuelle Stand der Mitgliedschaft kann folgenden Webseiten entnommen werden:  
 EA: [www.europeanaccreditation.org](http://www.europeanaccreditation.org)  
 IAF: [www.iaf.org](http://www.iaf.org)  
 ILAC: [www.ilac.org](http://www.ilac.org)

### Note:

The current certificate including annex is published on our website (see link below) or may be received from CETECOM ICT Services on request.

<http://www.cetecom.com/eu/de/cetecom-group/europa/deutschland-saarbruecken/akkreditierungen.html>