

---

# Chapter 5: Installation

---

This chapter describes how to install and test the hardware for a PTP 700 link. It contains the following topics:

- [Safety](#) on page 5-2 contains important safety guidelines that must be observed by personnel installing or operating PTP 700 equipment.
- [ODU variants and mounting bracket options](#) on page 5-6 provides details of six different bracket options, including the type of ODU and range of pole diameters supported by each option.
- [Installing the ODU and top LPU](#) on page 5-7 describes how to mount and ground a Connectorized+Integrated or Connectorized ODU, and how to mount and ground the top LPU.
- [Install external antennas](#) on page 5-14 describes how to mount and connect an external antenna for the Connectorized or Connectorized+Integrated ODU.
- [Installing the copper Cat5e Ethernet interface](#) on page 5-16 describes how to install the copper Cat5e power over Ethernet interface from the ODU (PSU port) to the PSU.
- [Installing the PSU](#) on page 5-24 describes how to install the AC+DC Enhanced Power Injector power supply unit for the PTP 700.
- [Installing a PTP-SYNC unit](#) on page 5-26 describes how to install a PTP-SYNC unit for TDD synchronization.
- [Installing a GPS receiver](#) on page 5-30 describes how to install a GPS receiver as the timing reference source for PTP-SYNC.
- [Installing a NIDU](#) on page 5-40 describes how to install a network indoor unit (NIDU) for TDM (T1 or E1) interfaces.
- [Installing an SFP Ethernet interface](#) on page 5-26 describes how to install an optical or copper Cat5e Ethernet interface from the ODU (SFP port) to a connected device.
- [Installing an Aux Ethernet interface](#) on page 5-55 describes how to install a copper Cat5e Ethernet interface from the ODU (Aux port) to a connected device.
- [Supplemental installation information](#) on page 5-56 contains detailed installation procedures that are not included in the above topics, such as how to strip cables, create grounding points and weatherproof connectors.



## Note

These instructions assume that LPUs are being installed from the PTP 650/700 LPU and grounding kit (Cambium part number C000065L007). If the installation does not require LPUs, adapt these instructions as appropriate.

If LPUs are being installed, only use the five black-capped EMC cable glands supplied in the LPU and grounding kit. The silver-capped cable glands supplied in the ODU kits must only be used in PTP 700 installations which do not require LPUs.

---

# Safety

---



## Warning

To prevent loss of life or physical injury, observe the following safety guidelines. In no event shall Cambium Networks be liable for any injury or damage caused during the installation of the Cambium PTP 700. Ensure that only qualified personnel install a PTP 700 link.

---

## Hazardous locations

---



## Warning

When installing the PTP 700 ATEX/HAZLOC product variants in hazardous locations, follow the instructions contained in the PTP 700 Series Hazardous Location Guide (supplied in box with the products), in addition to the instructions in this user guide.

---

## Power lines

Exercise extreme care when working near power lines.

## Working at heights

Exercise extreme care when working at heights.

## PSU

Always use one of the Cambium PTP 700 Series power supply units (PSU) to power the ODU. Failure to use a Cambium supplied PSU could result in equipment damage and will invalidate the safety certification and may cause a safety hazard.

## Grounding and protective earth

The Outdoor Unit (ODU) must be properly grounded to protect against lightning. It is the user's responsibility to install the equipment in accordance with national regulations. In the USA follow the requirements of the National Electrical code NFPA 70-2005 and 780-2004 *Installation of Lightning Protection Systems*. In Canada, follow Section 54 of the *Canadian Electrical Code*. These codes describe correct installation procedures for grounding the outdoor unit, mast, lead-in wire and discharge unit, size of grounding conductors and connection requirements for grounding electrodes. Other regulations may apply in different countries and therefore it is recommended that installation of the outdoor unit be contracted to a professional installer.

## DC supply

To power the ODU from a DC supply, use the PTP 650/700 AC+DC Enhanced Power Injector (PSU) (Cambium part number C000065L002). Ensure that the DC power supply meets the requirements specified in [PSU DC power supply](#) on page 3-15.

## Powering down before servicing

Before servicing PTP 700 equipment, always switch off the power supply and unplug it from the PSU.

Do not disconnect the RJ45 drop cable connectors from the ODU while the PSU is connected to the power supply. Always remove the AC or DC input power from the PSU.

## Primary disconnect device

The main power supply is the primary disconnect device. The AC+DC Enhanced power injector is fused on the DC input. Some installations will also require an additional circuit breaker or isolation switch to be fitted in the DC supply.

## External cables

Safety may be compromised if outdoor rated cables are not used for connections that will be exposed to the outdoor environment. For outdoor copper Cat5e Ethernet interfaces, always use Cat5e cable that is gel-filled and shielded with copper-plated steel. Alternative types of drop cable are not supported by Cambium Networks.

## Drop cable tester

The PSU output voltage may be hazardous in some conditions, for example in wet weather. Do NOT connect the drop cable tester to the PSU, either directly or via LPUs.

## Grounding PTP-SYNC

In order to meet the safety requirements for deployment in Australia and New Zealand (AS/NZS 60950-1), the PTP-SYNC unit, if deployed, must be grounded to a Protective Ground in accordance with Local Electrical Regulations.

## RF exposure near the antenna

Strong radio frequency (RF) fields will be present close to the antenna when the transmitter is on. Always turn off the power to the ODU before undertaking maintenance activities in front of the antenna.

## Minimum separation distances

Ensure that personnel are not exposed to unsafe levels of RF energy. The units start to radiate RF energy as soon as they are powered up. Never work in front of the antenna when the ODU is powered. Install the ODUs so as to provide and maintain the minimum separation distances from all persons. For minimum separation distances, see [Calculated distances](#) on page 4-24.

## Grounding and lightning protection requirements

Ensure that the installation meets the requirements defined in [Grounding and lightning protection](#) on page 3-11.

## Grounding cable installation methods

To provide effective protection against lightning induced surges, observe these requirements:

- Grounding conductor runs are as short, straight and smooth as possible, with bends and curves kept to a minimum.
- Grounding cables must not be installed with drip loops.
- All bends must have a minimum radius of 200 mm (8 in) and a minimum angle of 90°. A diagonal run is preferable to a bend, even though it does not follow the contour or run parallel to the supporting structure.
- All bends, curves and connections must be routed towards the grounding electrode system, ground rod, or ground bar.
- Grounding conductors must be securely fastened.
- Braided grounding conductors must not be used.
- Approved bonding techniques must be used for the connection of dissimilar metals.

## Siting ODUs and antennas

ODUs, external antennas and GPS receivers for PTP-SYNC are not designed to survive direct lightning strikes. For this reason they must be installed in Zone B as defined in [Lightning protection zones](#) on page 3-11. Mounting in Zone A may put equipment, structures and life at risk.

## Thermal Safety

The ODU enclosure may be hot to the touch when in operation. The ODU must not be operated in ambient temperatures exceeding 40°C unless mounted in a Restricted Access Location. For more information, see [ODU ambient temperature limits](#) on page 3-13.

**Warning**

Do not install the ODU in a location where the ambient temperature could exceed 40°C unless this is a Restricted Access Location as defined by EN 60950-1.

**Alerte**

L'unité externe ne doit pas être installée dans un endroit où la température ambiante est supérieure à 40C à moins que l'accès soit limité au personnel autorisé.

---

## ODU variants and mounting bracket options

### Mounting bracket options

The PTP 700 series supports five mounting bracket options. Select the optimum mounting bracket arrangement based on the pole diameter and the ODU variant:

**Table 113** ODU mounting bracket part numbers

Bracket	Pole diameter	ODU variants	Bracket part number
Mounting bracket (integrated)	40 mm to 82 mm (1.6 inches to 3.2 inches)	PTP 700 Connectorized+Integrated	N000065L031
Mounting bracket (connectorized)	40 mm to 82 mm (1.6 inches to 3.2 inches)	PTP 700 Connectorized	N000065L032
Extended integrated mounting bracket	89 mm <i>OR</i> 114 mm (3.5 inches <i>OR</i> 4.5 inches)	PTP 700 Connectorized PTP 700 Connectorized+Integrated	N000065L030
Mounting bracket (integrated) with large diameter extension kit	89 mm to 229 mm (3.5 inches to 9.0 inches)	PTP 700 Connectorized PTP 700 Connectorized+Integrated	N000065L031 with N000065L042



#### Note

The connectorized mounting bracket is included with the PTP 700 Connectorized ODU. Order a bracket separately for PTP 700 Connectorized+Integrated ODUs.

## Installing the ODU and top LPU

---

To install the ODU and top LPU, use the following procedures:

- [Attach ground cables to the ODU](#) on page 5-7
- [Mount the ODU on the mast](#) on page 5-7
- [Mount the top LPU](#) on page 5-12
- [Interconnect and ground the ODU and top LPU](#) on page 5-12

### Attach ground cables to the ODU

- 1 Fasten one ground cable to each ODU grounding point using the M6 (small) lugs: one is for the top LPU (M6 lug at other end) and the other is for the tower or building (M10 lug at other end). It does not matter which cable goes on which ODU grounding point.
- 2 Tighten both ODU grounding bolts to a torque of 5 Nm (3.9 lb ft).



### Mount the ODU on the mast

Select the most appropriate bracket mounting arrangement from the options listed in [Mounting bracket options](#) on page 5-6. Refer to individual procedures below for each of the options:

- [Mounting bracket \(integrated\)](#) on page 5-8
- [Mounting bracket \(connectorized\)](#) on page 5-9
- [Extended integrated mounting bracket](#) on page 5-10
- [Mounting bracket \(integrated\) with large diameter extension kit](#) on page 5-11

The procedure for the Mounting bracket (connectorized) can be readily adapted to attach the ODU to a horizontal pole of similar size.

The procedure for the Mounting bracket (integrated) and the Extended integrated mounting bracket can be adapted to attach the ODU to a suitable horizontal pole, but the adjustment of azimuth angle is necessarily limited compared with an installation on a vertical pole.

## Mounting bracket (integrated)



### Caution

Do not reverse the bracket clamp, as this arrangement may lead to failure of the assembly. Do not over-tighten the bolts as this may lead to failure of the assembly.

- 1 Fix the mounting plate to the back of the ODU using the four bolts, and spring and plain washers provided. Tighten the bolts to a torque setting of 5.0 Nm (3.7 lb ft).
- 2 Attach the bracket body to the mounting plate using the M8 bolt, spring and plain washers.
- 3 Hoist the ODU to the mounting position.
- 4 Attach the bracket body to the pole using the bracket clamp, M8 bolts, and spring and plain washers. For back-to-back mounting, use the LPU in place of the clamp.
- 5 Adjust the elevation and azimuth to achieve visual alignment. Tighten all three bracket bolts to a torque of 8.0 Nm (6.0 lb ft).

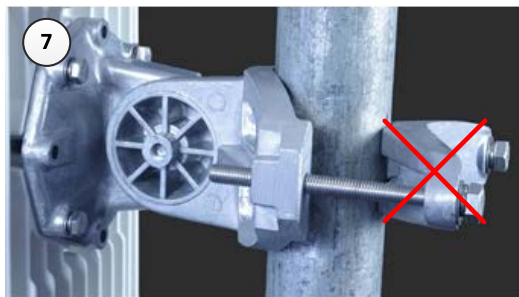
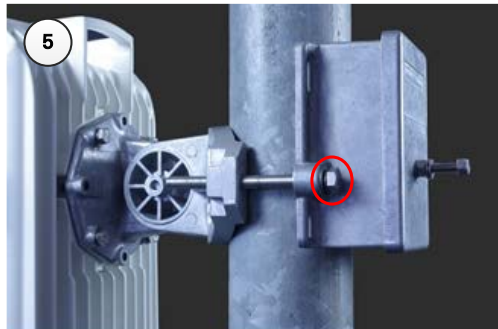
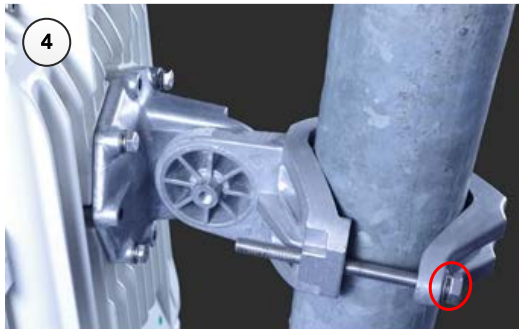
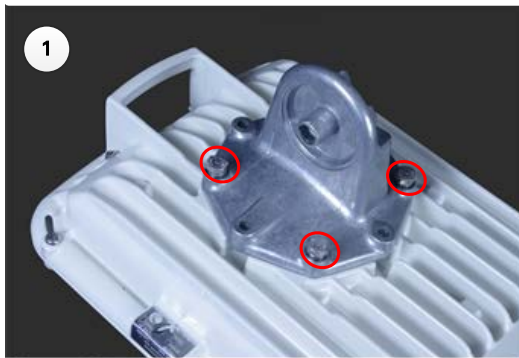



## Mounting bracket (connectorized)

- 1 Identify the square cavities in the casting on the back of the ODU. These cavities will be used to accommodate the heads of two M8 bracket bolts.
- 2 Fix the mounting plate to the ODU using the four M6 bolts, and spring and plain washers provided. Ensure that the M8 bolts are correctly held between the mounting plate and the ODU. Tighten the M6 bolts to a torque setting of 5.0 Nm (3.7 lb ft).
- 3 Hoist the ODU to the mounting position.
- 4 Attach the bracket body to the pole using the bracket clamp, spring and plain washers, and M8 nuts.
- 5 Alternatively, use the LPU in place of the clamp to provide a back-to-back arrangement.
- 6 Tighten the two M8 bracket bolts to a torque setting of 8.0 Nm (6.0 lb ft). Do not over-tighten the bolts as this may lead to failure of the assembly.

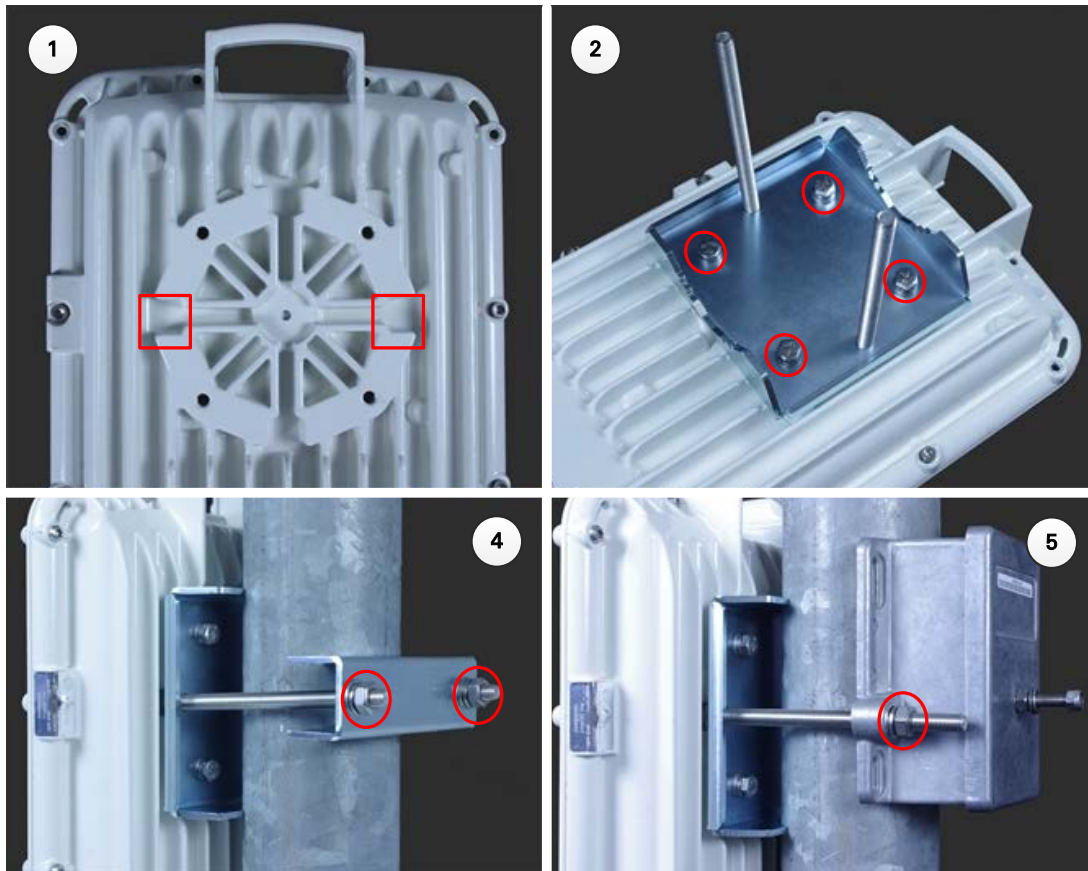

## Extended integrated mounting bracket

- 1 Fix the mounting plate to the back of the ODU using the four M6 bolts, and spring and plain washers provided. Tighten the bolts to a torque setting of 5.0 Nm (3.7 lb ft). The step is common with the standard integrated bracket.
- 2 Attach the bracket body of the extended bracket on the mounting plate on the ODU to using the M8 bolt and spring and plain washer.
- 3 Hoist the ODU to the mounting position.
- 4 Select the correct clamp. The larger clamp is intended for poles of diameter 114 mm (4.5 inches). The smaller clamp is intended for poles of diameter 89 mm (3.5 inches).
- 5 Attach the bracket body to the pole using the selected bracket clamp, washers and M8 bolts.
- 6 Adjust the elevation and azimuth to achieve visual alignment. Tighten all three M8 bracket bolts to a torque setting of 8.0 Nm (6.0 lb ft). Do not over-tighten the bolts as this may lead to failure of the assembly.

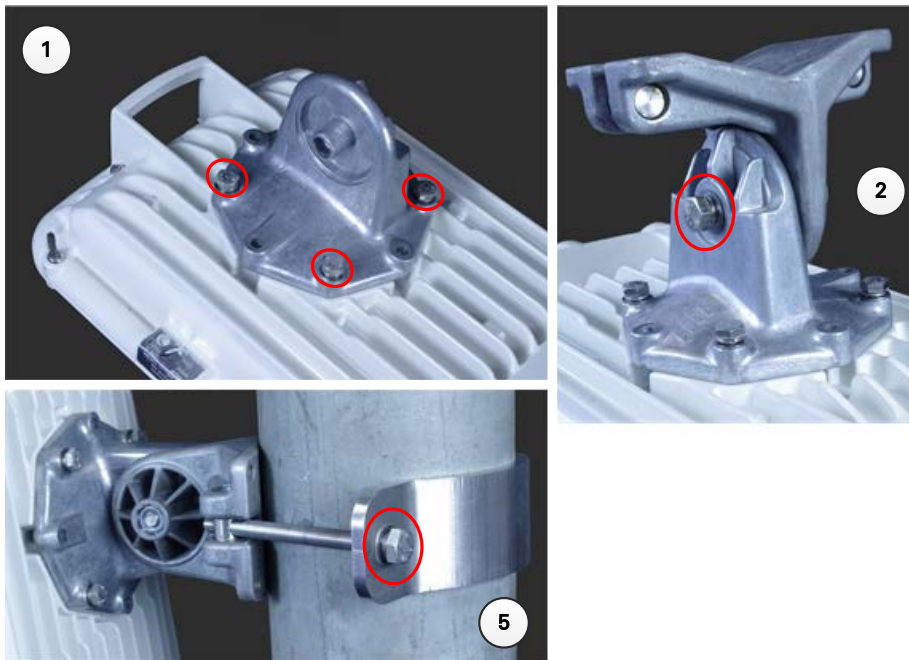

## Mounting bracket (integrated) with large diameter extension kit

- 1 Fix the mounting plate to the back of the ODU using the bolts and washers provided. Tighten the four bolts to a torque setting of 5.0 Nm (3.7 lb ft). Attach the bracket body to the mounting plate using the M8 bolt and spring and plain washer. This is equivalent to the first two steps for the standard integrated bracket.
- 2 Attach the adaptor plate of the large diameter extension kit to the bracket body using the bolts and washers provided. Tighten the two bolts to a torque setting of 5.0 Nm (3.7 lb ft).
- 3 Feed the Jubilee straps through the slots in the adaptor plate.
- 4 Hoist the ODU to the mounting position.
- 5 Attach the adaptor plate to the pole using the Jubilee straps.
- 6 Adjust the azimuth to achieve visual alignment. Tighten the Jubilee straps to a torque setting of 6.0 Nm (4.5 lb ft).
- 7 Adjust the elevation to achieve visual alignment. Tighten M8 bracket bolt to a torque setting of 8.0 Nm (6.0 lb ft). Do not over-tighten this bolt as this may lead to failure of the assembly.

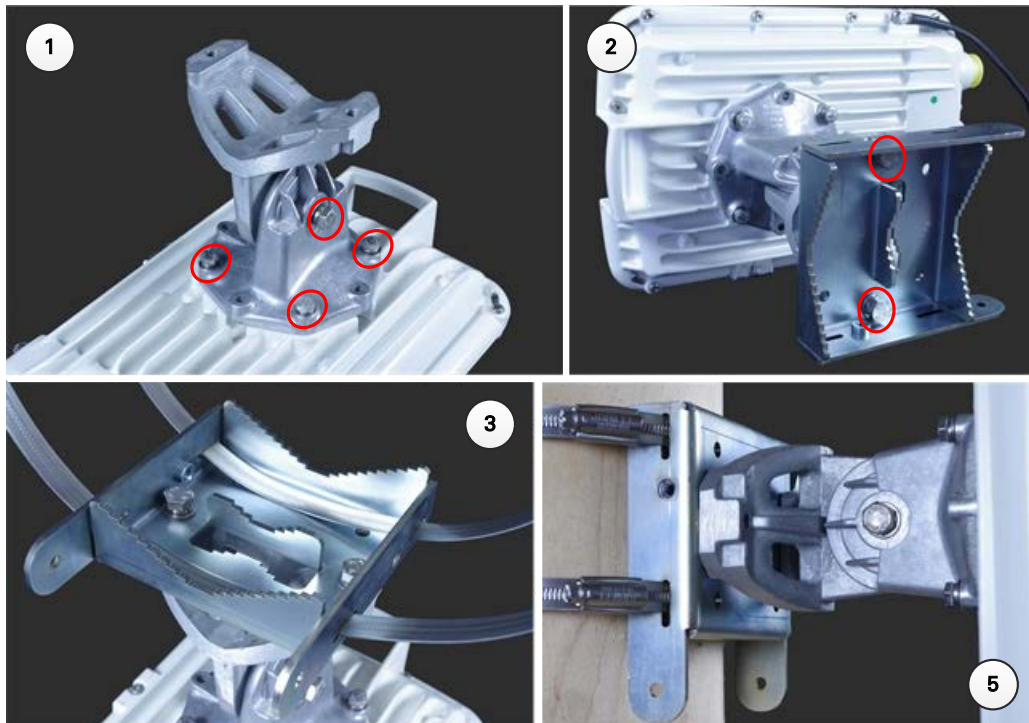

## Mount the top LPU

- 1 For separate LPU mounting, use the U-bolt bracket from the LPU kit to mount the top LPU on the pole below the ODU. Tighten to a torque setting of 7.0 Nm (5.2 lb ft):

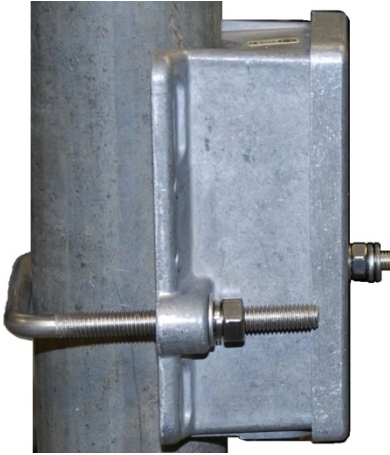

## Interconnect and ground the ODU and top LPU

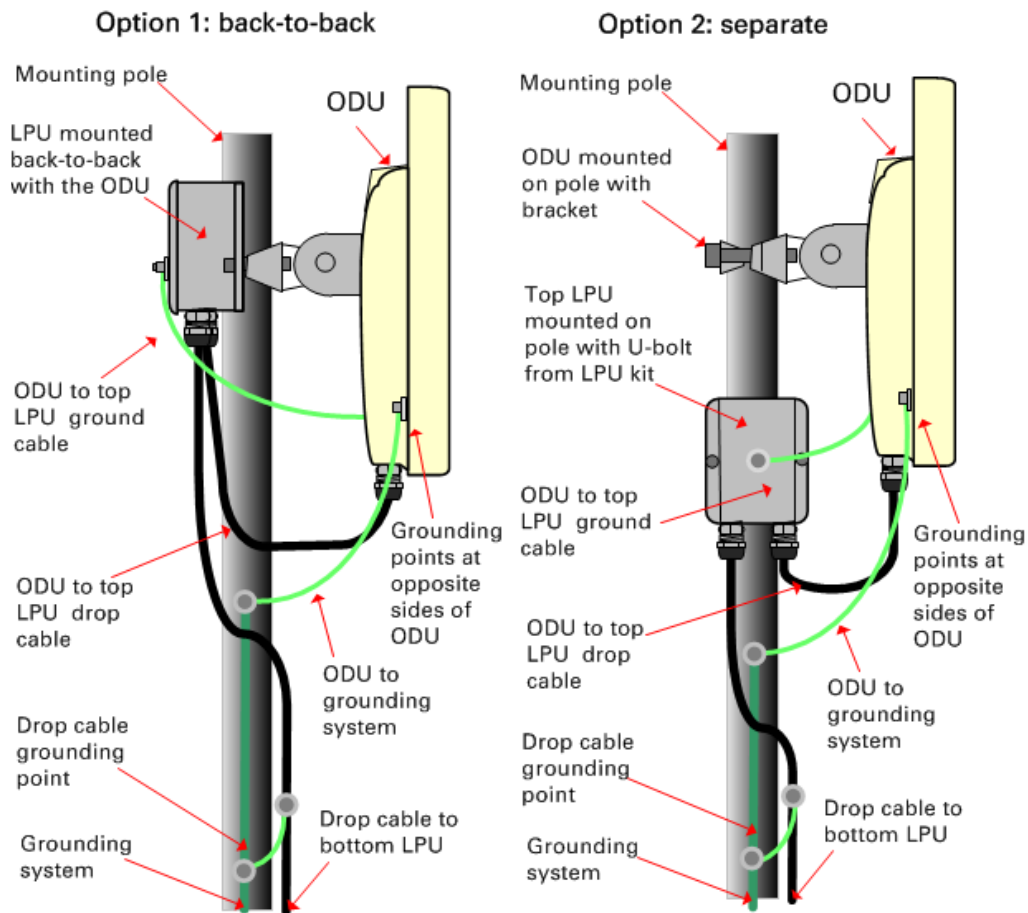

**Caution**

Do not attach grounding cables to the ODU mounting bracket bolts, as this arrangement will not provide full protection.

- 1 Fasten the ODU grounding cable to the top LPU using the M6 (small) lug. Tighten both nuts to a torque of 5 Nm (3.9 lb ft):

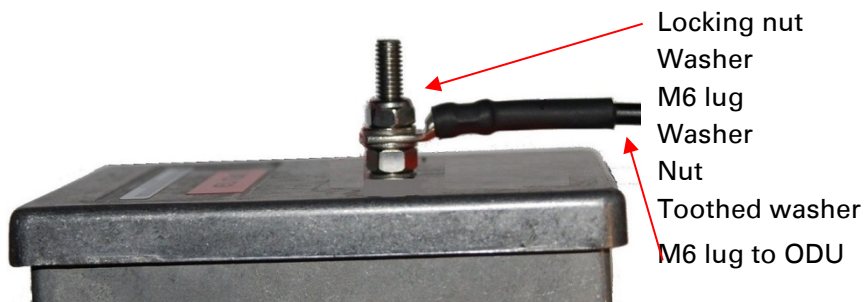

- 2 Select a tower or building grounding point within 0.3 meters (1 ft) of the ODU bracket. Remove paint from the surface and apply anti-oxidant compound. Fasten the ODU grounding cable to this point using the M10 (large) lug.
- 3 If local regulations mandate the independent grounding of all devices, add a third ground cable to connect the top LPU directly to the grounding system.

## Install external antennas

To mount and connect an external antenna, proceed as follows:

- 1 Mount the antenna(s) according to manufacturer's instructions. When using separate antennas to achieve spatial diversity, mount one with Horizontal polarization and the other with Vertical polarization.
- 2 Connect the ODU V and H interfaces to the antenna(s) with RF cable of type LMR-400 (Cambium part numbers 30010194001 and 30010195001) and N type connectors (Cambium part number 09010091001). Tighten the N type connectors to a torque setting of 1.7 Nm (1.3 lb ft).
- 3 If the ODU is mounted indoors, install lightning arrestors at the building entry point:
- 4 Form drip loops near the lower ends of the antenna cables. These ensure that water is not channeled towards the connectors.
- 5 If the ODU is mounted outdoors, weatherproof the N type connectors (when antenna alignment is complete) using PVC tape and self-amalgamating rubber tape.
- 6 Weatherproof the antenna connectors in the same way (unless the antenna manufacturer specifies a different method).

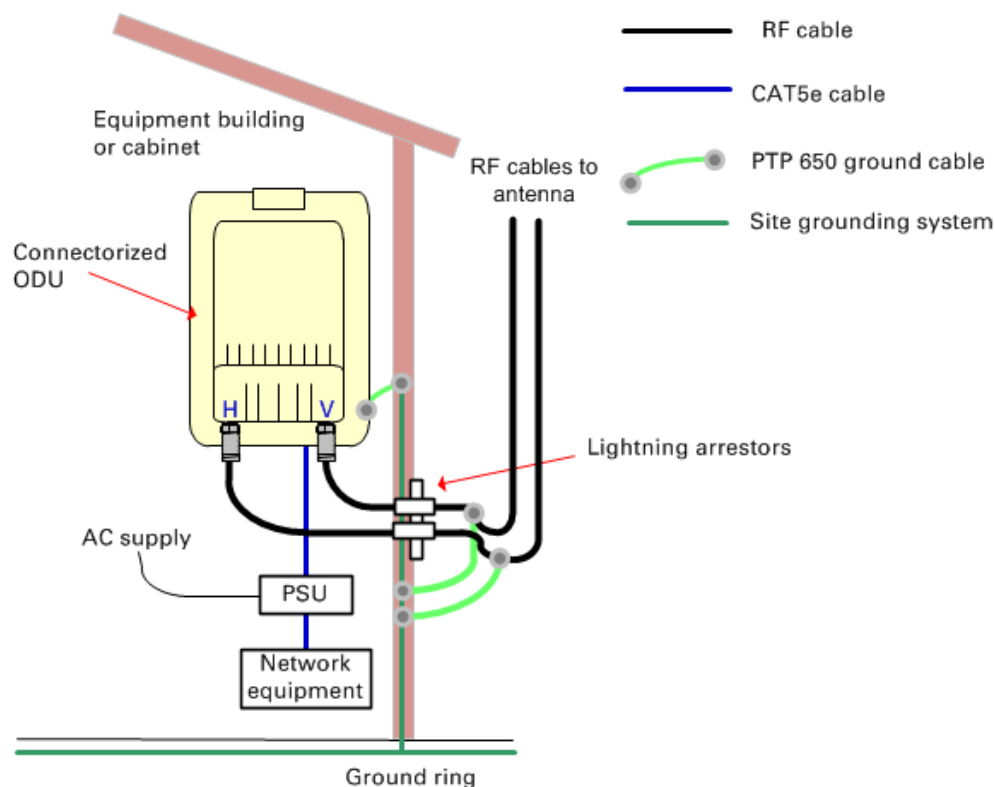

- 7 Ground the antenna cables to the supporting structure within 0.3 meters (1 foot) of the ODU and antennas using the Cambium grounding kit (part number 01010419001):

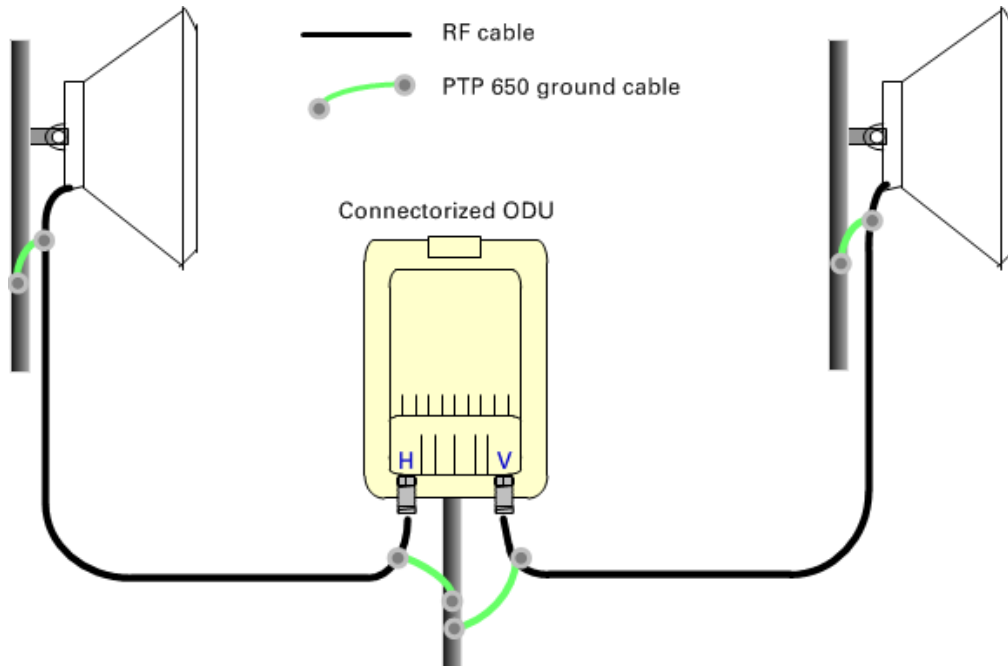

- 8 Fix the antenna cables to the supporting structure using site approved methods. Ensure that no undue strain is placed on the ODU or antenna connectors. Ensure that the cables do not flap in the wind, as flapping cables are prone to damage and induce unwanted vibrations in the supporting structure.



## Installing the copper Cat5e Ethernet interface

To install the copper Cat5e Ethernet interface, use the following procedures:

- [Install the ODU to top LPU drop cable](#) on page 5-16
- [Install the main drop cable](#) on page 5-18
- [Install the bottom LPU to PSU drop cable](#) on page 5-21
- [Test resistance in the drop cable](#) on page 5-23



### Caution

To avoid damage to the installation, do not connect or disconnect the drop cable when power is applied to the PSU or network terminating equipment.



### Caution

Do not connect the SFP or Aux drop cables to the PSU, as this may damage equipment.



### Caution

Always use Cat5e cable that is gel-filled and shielded with copper-plated steel. Alternative types of Cat5e cable are not supported by Cambium Networks. Cambium Networks supply this cable (Cambium part numbers WB3175 and WB3176), RJ45 connectors (Cambium part number WB3177) and a crimp tool (Cambium part number WB3211). The LPU and grounding kit contains a 600 mm length of this cable.

## Install the ODU to top LPU drop cable

### Fit glands to the ODU to top LPU drop cable

Fit EMC strain relief cable glands (with black caps) to both ends of the 600 mm length of pre-terminated cable. These parts are supplied in the LPU and grounding kit.

- 1 Disassemble the gland and thread each part onto the cable (the rubber bung is split). Assemble the spring clip and the rubber bung:

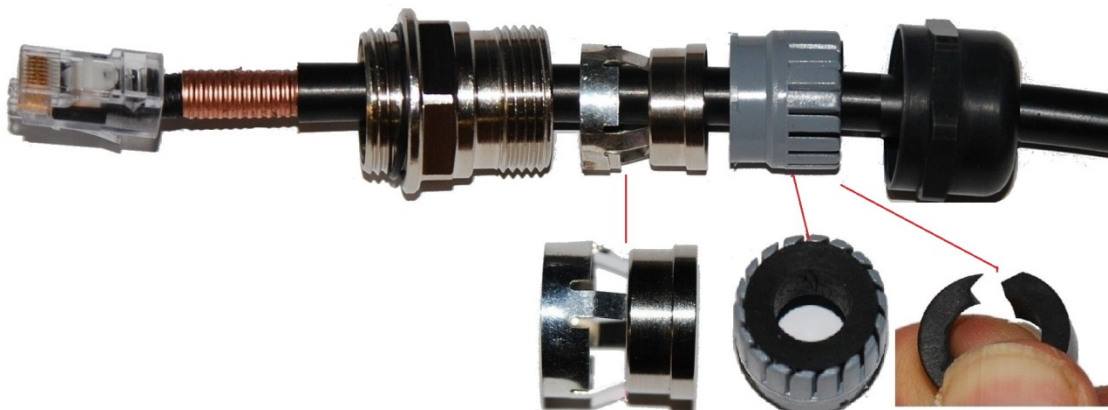



- 2 Fit the parts into the body and lightly screw on the gland nut (do not tighten it):

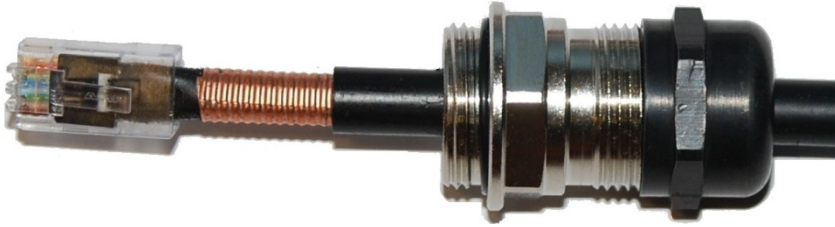

## Connect the drop cable to the ODU (PSU port) and LPU

- 1 (a) Plug the RJ45 connector into the socket in the unit, ensuring that it snaps home.  
 (b) Fit the gland body to the RJ45 port and tighten it to a torque of 5.5 Nm (4.3 lb ft):

(a)



(b)



- 2 (a) Fit the gland nut and tighten until the rubber seal closes on the cable. (b) Do not over-tighten the gland nut, as there is a risk of damage to its internal components:

(a)



(b)

Correct



Incorrect



## Disconnect the drop cable from the LPU or ODU

Use this procedure if it is necessary to remove an EMC strain relief cable gland and RJ45 connector from the ODU (as illustrated) or LPU.

- 1 (a) Remove the gland nut. Wiggle the drop cable to release the tension of the gland body. When the tension in the gland body is released, a gap opens at the point show. Unscrew the gland body.
- (b) Use a small screwdriver to press the RJ45 locking tab, then remove the RJ45 connector.

(a)



(b)



## Install the main drop cable



### Warning

The metal screen of the drop cable is very sharp and may cause personal injury.

- ALWAYS wear cut-resistant gloves (check the label to ensure they are cut resistant).
- ALWAYS wear protective eyewear.
- ALWAYS use a rotary blade tool to strip the cable (DO NOT use a bladed knife).



### Warning

Failure to obey the following precautions may result in injury or death:

- Use the proper hoisting grip for the cable being installed. If the wrong hoisting grip is used, slippage or insufficient gripping strength will result.
- Do not reuse hoisting grips. Used grips may have lost elasticity, stretched, or become weakened. Reusing a grip can cause the cable to slip, break, or fall.
- The minimum requirement is one hoisting grip for each 60 m (200 ft) of cable.

## Cut to length and fit hoisting grips

- 1 Cut the main drop cable to length from the top LPU to the bottom LPU.

- 2 Slide one or more hoisting grips onto the top end of the drop cable.
- 3 Secure the hoisting grip to the cable using a special tool, as recommended by the manufacturer.

## Terminate with RJ45 connectors and glands



### Caution

Check that the crimp tool matches the RJ45 connector, otherwise the cable or connector may be damaged.

- 1 Thread the cable gland (with black cap) onto the main drop cable.
- 2 Strip the cable outer sheath and fit the RJ45 connector load bar.
- 3 Fit the RJ45 connector housing as shown. To ensure there is effective strain relief, locate the cable inner sheath under the connector housing tang. Do not tighten the gland nut:

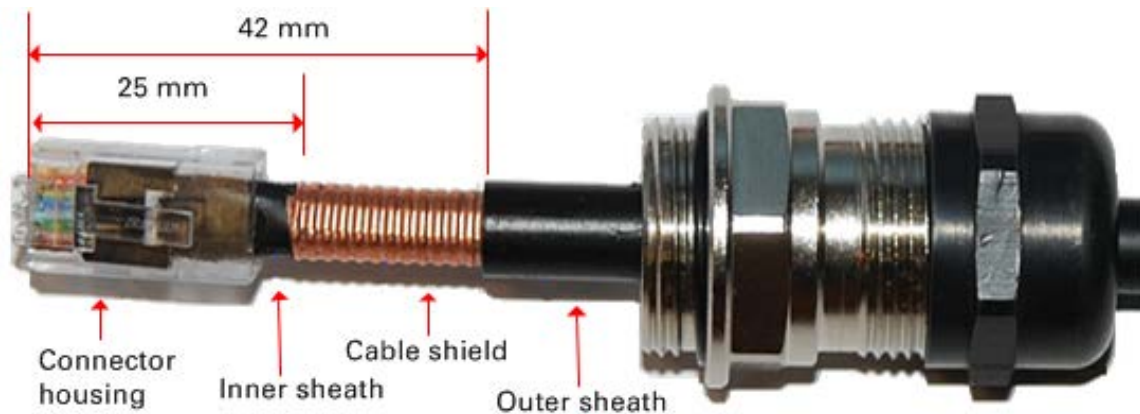

Pin	Color (Supplied cable)	Color (Conventional)	Pins on plug face
1	Light Orange	White/Orange	
2	Orange	Orange	
3	Light Green	White/Green	
4	Blue	Blue	
5	Light Blue	White/Blue	
6	Green	Green	
7	Light Brown	White/Brown	
8	Brown	Brown	

## Hoist and fix the main drop cable



### Warning

Failure to obey the following precautions may result in injury or death:

- Use the hoisting grip to hoist one cable only. Attempting to hoist more than one cable may cause the hoisting grip to break or the cables to fall.
- Do not use the hoisting grip for lowering cable unless the clamp is securely in place.
- Maintain tension on the hoisting grip during hoisting. Loss of tension can cause dangerous movement of the cable and result in injury or death to personnel.
- Do not release tension on the grip until after the grip handle has been fastened to the supporting structure.
- Do not apply any strain to the RJ45 connectors.



### Caution

Do not lay the drop cable alongside a lightning air terminal.

- 1 Hoist the top end of the main drop cable up to the top LPU, following the hoist manufacturer's instructions. When the cable is in position, fasten the grip handle to the supporting structure and remove the hoist line.
- 2 Connect the main drop cable to the top LPU by following the procedure [Connect the drop cable to the ODU \(PSU port\) and LPU](#) on page 5-17.
- 3 Run the main drop cable to the site of the bottom LPU.
- 4 Attach the main drop cable to the supporting structure using site approved methods.

## Ground the main drop cable

At all required grounding points, connect the screen of the main drop cable to the metal of the supporting structure using the cable grounding kit (Cambium part number 01010419001).

## Install the bottom LPU to PSU drop cable

### Install the bottom LPU

Install the bottom LPU, ground it, and connect it to the main drop cable.

- 1 Select a mounting point for the bottom LPU within 600 mm (24 in) of the building entry point. Mount the LPU vertically with cable glands facing downwards.

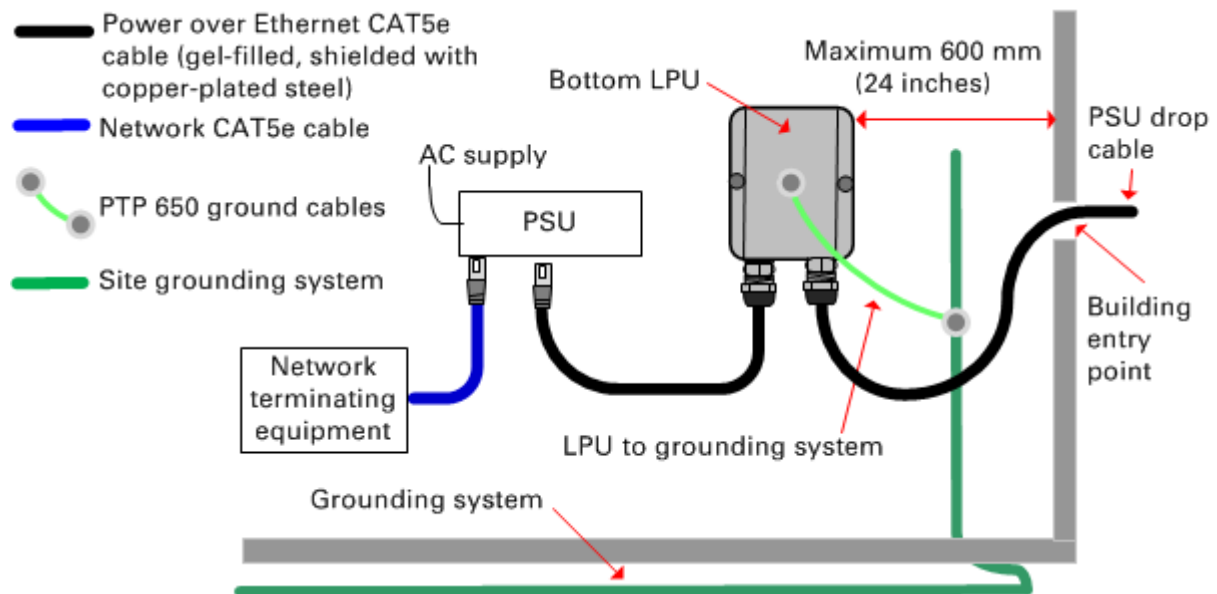

- 2 Connect the main drop cable to the bottom LPU by following the procedure [Connect the drop cable to the ODU \(PSU port\) and LPU](#) on page 5-17.
- 3 Fasten one ground cable to the bottom LPU using the M6 (small) lug. Tighten both nuts to a torque of 5 Nm (3.9 lb ft):

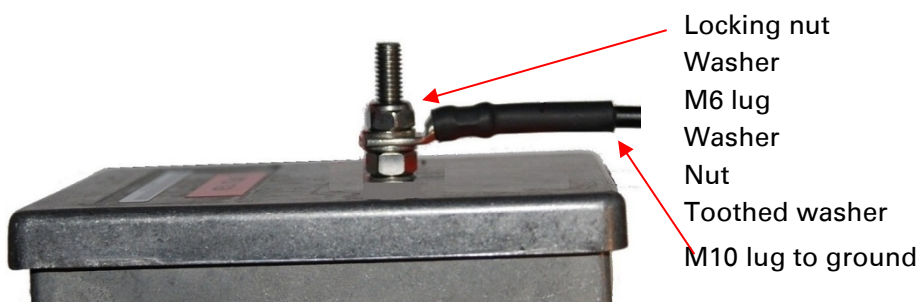

- 4 Select a building grounding point near the LPU bracket. Remove paint from the surface and apply anti-oxidant compound. Fasten the LPU ground cable using the M10 (large) lug.

## Install the LPU to PSU drop cable

Use this procedure to terminate the bottom LPU to PSU drop cable with RJ45 connectors at both ends, and with a cable gland at the LPU end.



### Warning

The metal screen of the drop cable is very sharp and may cause personal injury. ALWAYS wear cut-resistant gloves (check the label to ensure they are cut resistant). ALWAYS wear protective eyewear. ALWAYS use a rotary blade tool to strip the cable, not a bladed knife.



### Caution

Check that the crimp tool matches the RJ45 connector, otherwise the cable or connector may be damaged.

---

- 1 Cut the drop cable to the length required from bottom LPU to PSU.
- 2 **At the LPU end only:**
  - Fit one cable gland and one RJ45 connector by following the procedure [Terminate with RJ45 connectors and glands](#) on page 5-19.
  - Connect this cable and gland to the bottom LPU by following the procedure [Connect the drop cable to the ODU \(PSU port\) and LPU](#) on page 5-17.
- 4 **At the PSU end only:** Do not fit a cable gland. Strip the cable outer sheath and fit the RJ45 connector load bar. Fit the RJ45 connector housing. To ensure there is effective strain relief, locate the cable inner sheath under the connector housing tang:

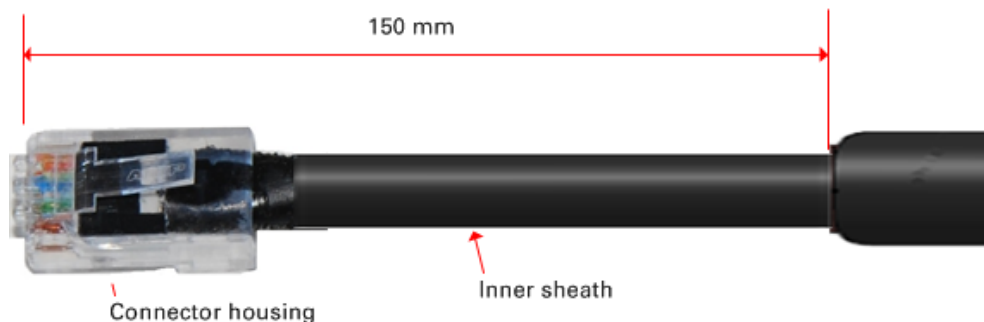

## Test resistance in the drop cable

Connect the bottom end of the copper Cat5e drop cable to a PTP drop cable tester and test that the resistances between pins are within the correct limits, as specified in the table below. If any of the tests fail, examine the drop cable for wiring faults. Order the PTP drop cable tester from the support website (<http://www.cambiumnetworks.com/support>).

Measure the resistance between...	Enter measured resistance	To pass test, resistance must be...	Circle "Pass" or "Fail"	Additional tests and notes
Pins 1 and 2	Ohms	<20 Ohms (60 Ohms) (*1)	Pass Fail	Resistances must be within 10% of each other (*2). Circle "Pass" or "Fail": Pass Fail
Pins 3 and 6	Ohms	<20 Ohms (60 Ohms) (*1)	Pass Fail	
Pins 4 and 5	Ohms	<20 Ohms (60 Ohms) (*1)	Pass Fail	
Pins 7 and 8	Ohms	<20 Ohms (60 Ohms) (*1)	Pass Fail	
Pin 1 and screen (ODU ground)	K Ohms	>100K Ohms	Pass Fail	These limits apply regardless of cable length.
Pin 8 and screen (ODU ground)	K Ohms	>100K Ohms	Pass Fail	

(\*1) A resistance of 20 Ohms is the maximum allowed when the cable is carrying Ethernet. A resistance of 60 Ohms is the maximum allowed when the cable is carrying only power to the ODU (when Ethernet is carried by one of the other ODU interfaces).

(\*2) Ensure that these resistances are within 10% of each other by multiplying the lowest resistance by 1.1 – if any of the other resistances are greater than this, the test has failed.



## Installing the PSU

Install the PTP 650/700 AC+DC Enhanced Power Injector (Cambium part number C000065L002). Refer to [Installing the AC+DC Enhanced Power Injector](#) on page 5-24.



### Caution

As the PSU is not waterproof, locate it away from sources of moisture, either in the equipment building or in a ventilated moisture-proof enclosure. Do not locate the PSU in a position where it may exceed its temperature rating.



### Caution

Do not plug any device other than a PTP 700 ODU into the ODU port of the PSU. Other devices may be damaged due to the non-standard techniques employed to inject DC power into the Ethernet connection between the PSU and the ODU.

Do not plug any device other than a Cambium PTP 700 PSU into the PSU port of the ODU. Plugging any other device into the PSU port of the ODU may damage the ODU and device.

## Installing the AC+DC Enhanced Power Injector

Follow this procedure to install the AC+DC Enhanced Power Injector (Cambium part number C000065L002):

- 1 Mount the AC+DC power injector by screwing it to a vertical or horizontal surface using the four screw holes (circled):

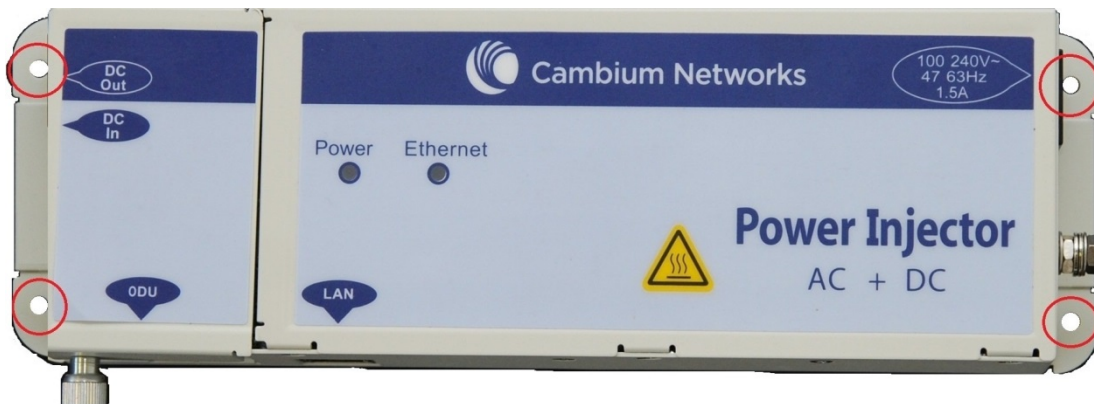

- 2 Form a drip loop on the PSU end of the LPU to PSU drop cable. The drip loop ensures that any moisture that runs down the cable into the cabinet or enclosure cannot enter the PSU.



- 3** (a) Undo the retaining screw, hinge back the cover and plug the drop cable or the cable from the PTP-SYNC into the port. (b) Close the cover and secure with the screw. (c) When the system is ready for network connection, connect the network Cat5e cable to the LAN port of the PSU:

(a)



(b) and (c)



## Installing a PTP-SYNC unit

---

To install a PTP-SYNC unit (for TDD synchronization), use the following procedures:

- [Mounting the PTP-SYNC unit](#) on page 5-26
- [Connecting up the PTP-SYNC unit](#) on page 5-27
- [Powering up the PTP-SYNC installation](#) on page 5-29



### Caution

The PTP-SYNC unit must be installed indoors in a non-condensing environment, otherwise it will be prone to water damage.



### Caution

To protect the PTP-SYNC from damage, disconnect the power supply from the PSU before connecting up the PTP-SYNC.

---

## Mounting the PTP-SYNC unit

Use this procedure to install the PTP-SYNC unit in the equipment building, either in a rack or on a wall.

- Racking mounting option: fix the PTP-SYNC to the rack mount using the M3 screws from the rack mount installation kit ([Figure 112](#)).
- Wall mounting option: mount the PTP-SYNC vertically with interfaces and cabling facing downwards ([Figure 113](#)).

**Figure 112** PTP-SYNC mounted in a rack



**Figure 113** PTP-SYNC mounted on a wall

## Connecting up the PTP-SYNC unit

Use this procedure to connect the PTP-SYNC to the AC+DC Power Injector, ODU, GPS receiver (if fitted), and LPU (if fitted).

- 1 Disconnect the power supply from the AC+DC Power Injector.
- 2 If using GPS, connect the cable from the GPS unit to the GPS/SYNC IN port.



- 3 To link clustered PTP-SYNC units, connect the SYNC OUT port of the first PTP-SYNC to the GPS/SYNC IN port of the second PTP-SYNC in the chain. Repeat for subsequent PTP-SYNC units in the chain.



- 4 Connect the cable from the PSU to the PIDU IN port. A suitable 1 meter cable is included in the PTP-SYNC kit.



- 5 Connect the cable from the ODU to the ODU OUT port.



- 6 Use a grounding cable to connect the ground stud of the PTP-SYNC to the master ground bar of the building, or to the rack ground bar.



## Powering up the PTP-SYNC installation

Use this procedure to power up the PTP-SYNC installation.



### Caution

Ensure that all cables are connected to the correct interfaces of the PTP SYNC unit and the GPS receiver (if used). Ensure that the installation is correctly grounded. Failure to do so may result in damage to the equipment.

---

- 1 Connect the power supply to the PSU.
- 2 Within 90 seconds, the PTP-SYNC STATUS LED should blink once every second to show that satellite lock has been achieved.
- 3 If the system does not operate correctly, refer to [Testing PTP-SYNC](#) on page 8-15.



# Installing a GPS receiver

---

To install a GPS receiver as the timing reference source for PTP-SYNC, use the following procedures:

- [Mounting the GPS receiver](#) on page 5-30
- [Preparing the GPS drop cable](#) on page 5-30
- [Assembling an RJ45 plug and housing for GPS](#) on page 5-31
- [Assembling a 12 way circular connector](#) on page 5-33
- [Connecting the GPS drop cable](#) on page 5-37
- [Top grounding point for GPS adapter cable](#) on page 5-38
- [Installing and connecting the GPS LPU](#) on page 5-39

**Caution**

Prior to power-up of equipment, ensure that all cables are connected to the correct interfaces of the PTP-SYNC unit and the GPS receiver module. Failure to do so may result in damage to the equipment.

---

## Mounting the GPS receiver

Mount the GPS receiver (following manufacturer's instructions) upon either an external wall ([Figure 43](#)) or a metal tower or mast ([Figure 44](#)).

## Preparing the GPS drop cable

Use this procedure to make the main drop cable that will connect the GPS receiver to its bottom LPU. GPS drop cables do not require top LPUs.

**Caution**

Always use Cat5e cable that is gel-filled and shielded with copper-plated steel. Alternative types of cable are not supported by Cambium.

---

- 1 Measure the distance from the GPS receiver to the LPU site at building entry.
- 2 Cut the required length of drop cable.
- 3 Attach one or more hoisting grips to the top end of the cable, as described in [Install the main drop cable](#) on page 5-18.

- 4 Fit a suitable GPS connector to the top end of the drop cable:
  - If a GPS adapter cable kit is available, attach the plug housing and an RJ45 plug to the top end of the main GPS drop cable, as described in [Assembling an RJ45 plug and housing for GPS](#) on page 5-31.
  - If a GPS adapter cable kit is not available, fit a 12 way circular connector to the top end of the main drop cable as described in [Assembling a 12 way circular connector](#) on page 5-33.
- 5 Hoist the GPS drop cable safely up a tower or building, as described in [Install the main drop cable](#), on page 5-18.

## Assembling an RJ45 plug and housing for GPS

Use this procedure to assemble the plug housing over the end of the drop cable. This procedure is only performed when a GPS adapter cable kit is available. This kit is used to connect the Trimble Acutime™ GG GPS receiver or the Trimble Acutime™ Gold GPS receiver to the GPS drop cable.

The kit contains an adapter cable (GPS receiver circular connector to RJ45 socket) and an RJ45 plug housing. The plug housing should be assembled over the end of the drop cable to provide a sealed connection to the adapter cable.



### Note

These instructions are for the preparation of the Cambium-supplied drop cable type (Superior Essex BBDGE). Other types of cable may need different preparation methods.

- 1 Prepare the top end of the GPS drop cable.

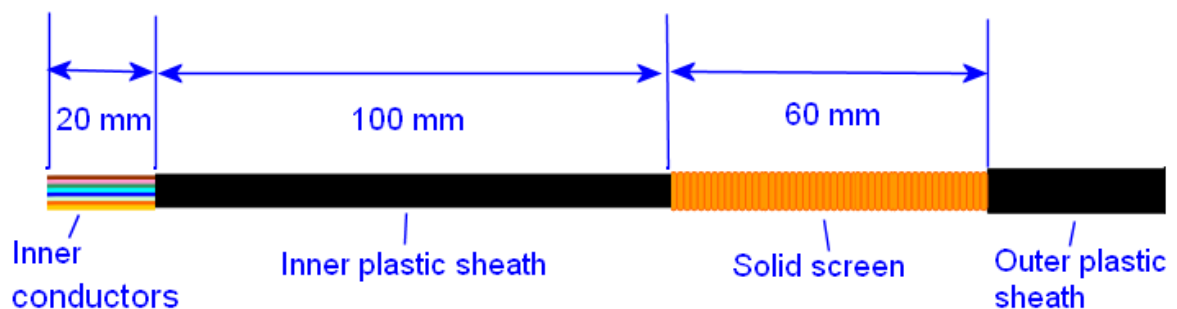

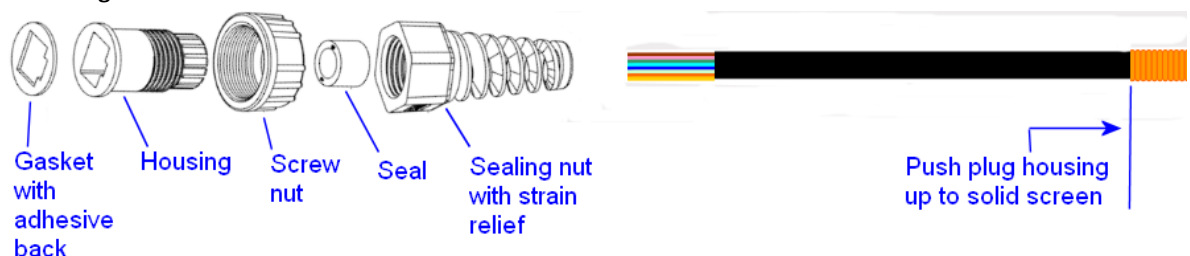

- 2 Install plug housing from the converter kit onto the prepared cable. Do not tighten the nuts at this stage.

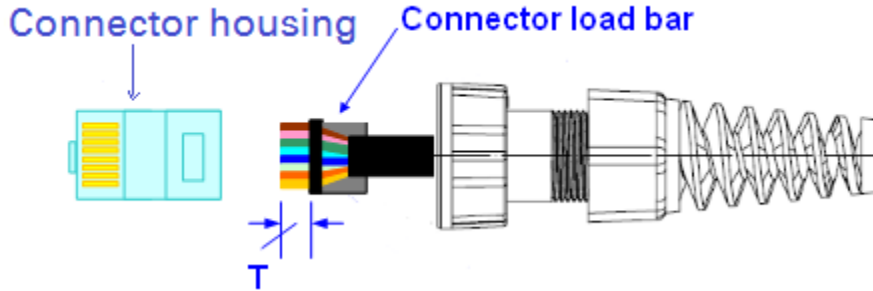

**3** Install the RJ45 crimp plug.



Start with tails over-length to assist insertion into load bar, then trim them to 5 mm (T). Connect the RJ45 pins to the following conductors (Superior Essex BBDGe colors):

Pin 8 Brown	
Pin 7 Light Brown	
Pin 6 Green	
Pin 5 Light Blue	
Pin 4 Blue	
Pin 3 Light Green	
Pin 2 Orange	
Pin 1 Light Orange	

**4** Assemble plug housing:

Depress the RJ45 locking tab (A).

Slide the plug housing assembly (B) over the RJ45 plug.

Tighten the sealing nut (C). This is easier to fully tighten when the plug housing is mated to the socket of the adapter cable.

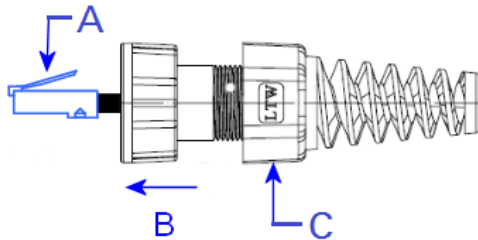

**5** Check the assembly. This is an example of an assembled plug housing on the end of a drop cable:





## Assembling a 12 way circular connector

Use this procedure to connect the GPS drop cable to a 12 way circular connector. This procedure is only performed when a GPS adapter cable kit is NOT available.



### Note

This procedure requires a soldering iron and solder.



### Caution

The drop cable has solid copper conductors. There are a limited number of times each conductor can be bent before it fatigues and fails.

Table 114 shows how the 12 way circular connector locations map to the PTP-SYNC RJ45 pins. Figure 114 illustrates this mapping.

**Table 114** GPS 12 way circular connector to RJ45 pin mappings

GPS connector location	Function	Cat5e wire color		PTP-SYNC (J10) RJ45 pin	PTP-SYNC signal name
		Conventional	Supported drop cable		
1	DC Pwr (12V)	Orange/White	Light Orange	1	12VGPS
2	RxB-	Brown/White	Light Brown	7	GPS_TXDA
3	RxB+	Brown	Brown	8	GPS_TXDB
4	TxB-	Blue	Blue	4	GPS_RXDA
5	TxB+	Blue/White	Light Blue	5	GPS_RXDB
6	RxA-	N.C	N.C	---	
7	RxA+	N.C	N.C	---	
8	TxA-	N.C	N.C	---	
9	DC Ground	Orange	Orange	2	GND
10	TxA+	N.C	N.C	---	
11	Tx1PPS+	Green/White	Light Green	3	GPS_1PPSA
12	Tx1PPS-	Green	Green	6	GPS_1PPSB

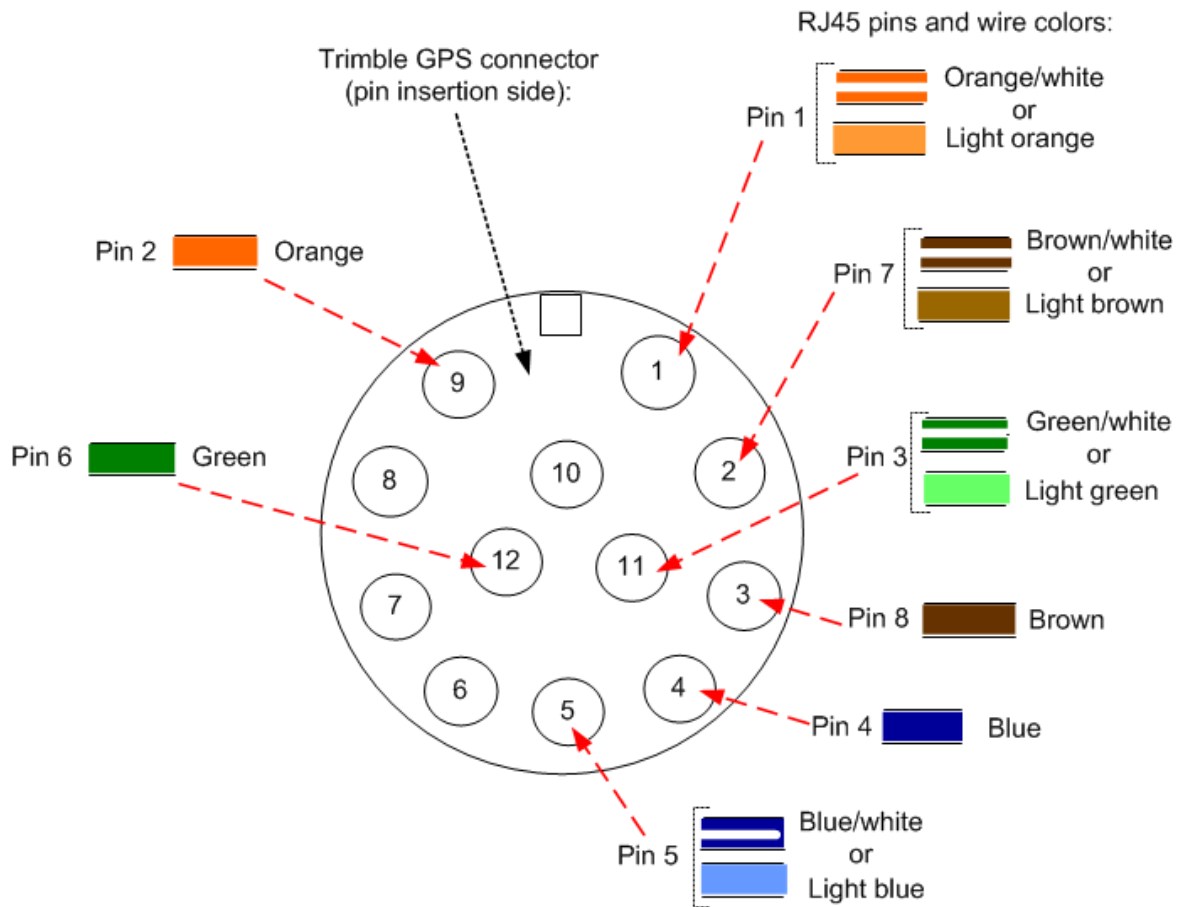
**Figure 114** Inserting RJ45 pins into the 12 way circular connector**1** Prepare the drop cable end as follows:

- Bare back the cable outer and copper screen to 50mm.
- Bare back the cable inner to 17mm.
- Un-twist the cable pairs.
- Strip the individual conductors to 5mm.



- 2 Fit the plug outer, associated boot, and boot insert.



- 3 Connect the socket contacts using either of the following techniques:

- **Crimp:** Crimp the socket contacts onto each of the conductors using the correct crimp tool and positioner, setting the wire size selector to "3" for 24AWG wire.



- **Solder:** When soldering the socket contacts onto each of the conductors, ensure that there is no solder or flux residue on the outside of the contact. Care should also be taken that the individual conductor insulation does not peel back with the soldering heat, allowing possible shorts when assembled into the plug shell.

- 4 Fit four dummy contacts into the unused 12 way circular connector locations (6, 7, 8 and 10), to provide strength and sealing. Push the contacts in from the pin insertion side.

Pin insertion side:

Plug mating side:



- 5 Insert the eight RJ45 contact pins into the pin insertion side of the 12 way circular connector in accordance with [Figure 114](#).

It is easiest to insert the pins from the center out, in descending order of Trimble location number, that is, 12, 11, 9, 5, 4, 3, 2, 1. Push the contacts in so that the shoulder on the contact fits into the hole in the plug shell. When all contacts have been fitted, push them in further to engage with the locking mechanism in the plug shell. This can be done by applying pressure to the contact with a small diameter stiff object, such as tweezers.

**Note**

If a contact is pushed in to the point where the locking mechanism engages before all of the contacts have been inserted it will limit the amount of room available to fit the remaining contacts, requiring harder bends to be applied.



- 6 Fit the plug to its shell. The plastic ring fits inside the rubber boot and ensures a tight fit when the plug body is clipped onto the plug shell. Be aware that the plug body is a hard push fit onto the plug shell.



- 7 Fit the strain relief clip.



## Connecting the GPS drop cable

Use this procedure to connect the GPS drop cable to the GPS unit and supporting structure.

- 1 If a GPS adapter cable is available, use it to connect the main GPS drop cable to the GPS unit:



- 2 If a GPS adapter cable is not available, connect the main GPS drop cable to the GPS unit via a 12 way circular connector. Weatherproof the connection as follows:
  - Wrap a layer of self-amalgamating tape, starting 25mm below the bared back outer of the cable and finishing at the GPS housing.
  - Wrap a layer of PVC tape, starting just below the start of the self-amalgamating tape and finishing at the GPS housing, overlapping at half width.
  - Repeat with four more layers of PVC tape alternating the start and finish ends.



- 3 Lay the main drop cable as far as the building entry point, ensuring there is enough length to extend through the wall of the building to the LPU.
- 4 Attach the main GPS drop cable to the supporting structure using site approved methods.
- 5 Ground the GPS drop cable to the supporting structure at the points shown in [Figure 43](#) (wall installation) or [Figure 44](#) (mast or tower installation):
  - For standard grounding instructions, see [Creating a drop cable grounding point](#) on page [5-57](#).
  - If a GPS adapter cable has been installed, see [Top grounding point for GPS adapter cable](#) on page [5-38](#).

## Top grounding point for GPS adapter cable

If a GPS adapter cable has been installed ([Figure 115](#)), use this procedure to ground the drop cable at the point where the solid screen is already exposed, and weatherproof both the ground cable joint and the RJ45 connection.

**Figure 115** Grounding and weatherproofing requirements for GPS adapter cable

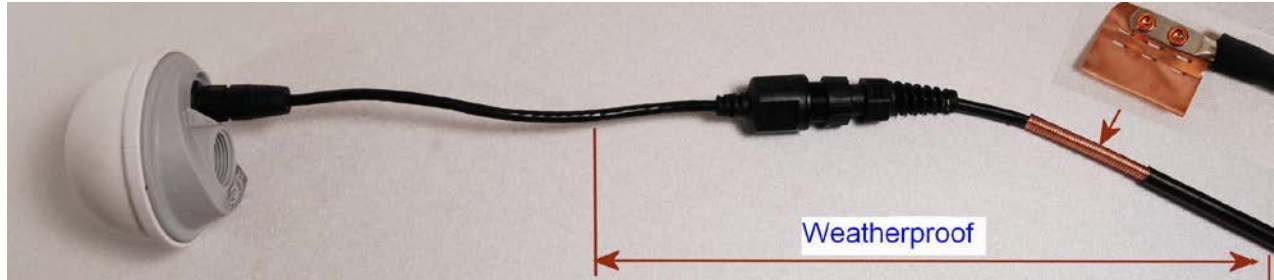

Follow the procedure described in [Creating a drop cable grounding point](#) on page 5-57, but observe the following differences:

- There is no need to remove 60mm (2.5inches) of the drop cable outer sheath, as this has already been done.
- Wrap the top layer of self-amalgamating tape around the complete assembly (not just the ground cable joint), including the RJ45 connection with the GPS adapter cable ([Figure 116](#)).
- Wrap all five layers of PVC tape around the complete assembly ([Figure 117](#)). Wrap the layers in alternate directions: (1st) bottom to top; (2nd) top to bottom; (3rd) bottom to top; (4th) top to bottom; (5th) bottom to top. The edges of each layer should be 25mm (1 inch) above (A) and 25 mm (1 inch) below (B) the previous layer.
- Check that the joint between the GPS adapter cable, drop cable and ground cable is fully weatherproofed ([Figure 118](#)).

**Figure 116** Wrapping self-amalgamating tape around the GPS adapter cable joint



**Figure 117** Wrapping PVC tape around the GPS adapter cable joint**Figure 118** Grounding and weatherproofing example for GPS adapter cable

## Installing and connecting the GPS LPU

Install and ground the GPS drop cable LPU at the building (or cabinet) entry point, and install the LPU-PTP-SYNC drop cable, as described in [Install the bottom LPU](#) on page 5-21.

Connect this cable to the PTP-SYNC unit as described in [Connecting up the PTP-SYNC unit](#) on page 5-27.



# Installing a NIDU

---

To install a NIDU (for TDM), use the following procedures:

- [Mounting the NIDU](#) on page 5-40
- [Connecting the NIDU to the PSU, LAN and TDM cables](#) on page 5-41
- [Connecting the NIDU to a DC power supply](#) on page 5-43

## Mounting the NIDU

Mount the NIDU in the equipment building, either in a rack or on a horizontal surface:

- Racking mounting option: fix the NIDU to the rack mount using the M3 screws from the rack mount installation kit ([Figure 119](#)). The rack can hold either two NIDUs or one NIDU and one PTP-SYNC unit.
- Horizontal option: place the NIDU on a horizontal surface.

**Figure 119** Two NIDUs mounted in a rack





## Connecting the NIDU to the PSU, LAN and TDM cables



### Caution

Always connect the NIDU to the Main PSU port of the ODU via the PSU. The TDM service will not operate if the NIDU is connected to the Aux or SFP port of the ODU.



### Caution

If the ODU port has negotiated a link at 100BASE-T, the NIDU will not send or receive TDM data and will not bridge customer data traffic. Ensure that the Ethernet drop cable between the ODU and the PSU, and the network cable between the PSU and the NIDU, will reliably support operation at 1000BASE-T.



### Note

Use the E1/T1 ports in ascending numeric sequence, for example: if there is one E1/T1 channel, use port 1; if are three E1/T1 channels, use ports 1, 2 and 3.

Use this procedure to connect the NIDU to the PSU, LAN and TDM transceivers.

- 1 Disconnect the power supply from the PSU.
- 2 Connect an indoor Cat5e cable from the NIDU (ODU port 3) to the PSU (LAN port):

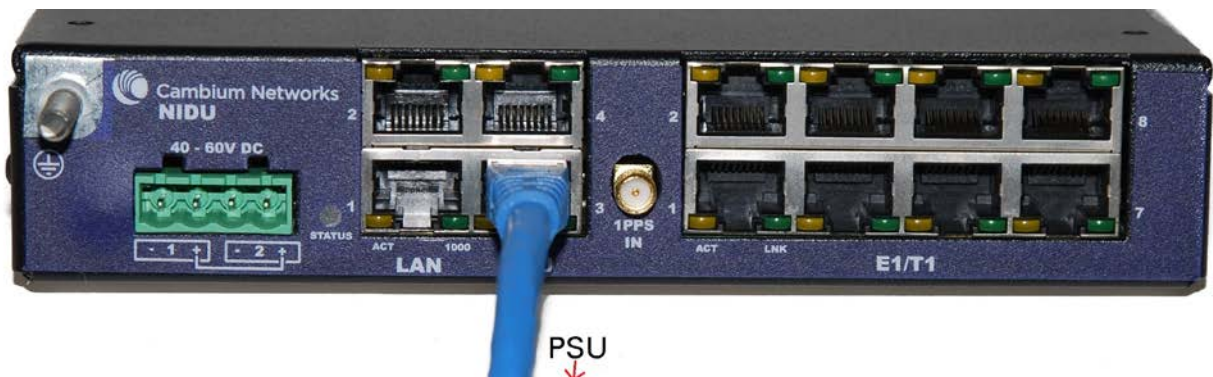

- 3 Connect an indoor Cat5e cable from the NIDU (LAN port 1) to the Ethernet network terminating equipment:



- 4 Connect up to eight indoor Cat5e cables (with RJ48 connectors) from the NIDU (E1/T1 ports) to the local TDM transceivers:



- 5 Use an M5 nut and washer to connect the grounding cable lug to the NIDU ground bolt. Connect the other end of the grounding cable to the master ground bar of the building or rack.



## Connecting the NIDU to a DC power supply



### Caution

Do not power up the NIDU until site installation is complete, otherwise equipment may be damaged.

## Main and backup DC supplies

The NIDU requires a 40 V – 60 V DC power supply. The NIDU DC interface provides inputs for a main and a backup DC power supply (Figure 120). The main DC supply (port 1) is mandatory, but the backup (port 2) is optional.

Figure 120 NIDU DC interface

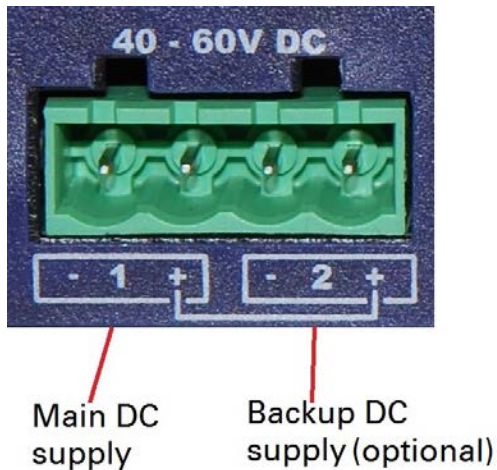

Use one of the following power supply options for the NIDU:

- The PTP 700 AC+DC Enhanced Power Injector (Cambium part number C000065L002) with optional backup.
- An independent DC supply (if available) with optional backup.
- The PTP 800 AC-DC Power Supply Converter (Cambium part number WB3622).

## Using the DC power connector

Use this procedure to connect the NIDU to the PTP 650/700 AC+DC Enhanced Power Injector (Cambium part number C000065L002) or to an independent DC supply with an optional backup DC supply:

- 1 Strip the two wires of the main DC supply cable and screw them into the first and second terminals of the DC power connector (Cambium part number C000065L044). The first terminal is negative (black wire) and the second is positive (red wire). If a backup supply is required, use the third and fourth terminals of the connector:

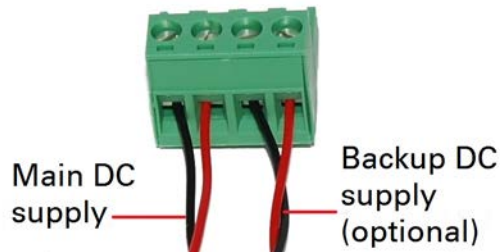

- 2 Plug the DC power connector into the NIDU DC interface:

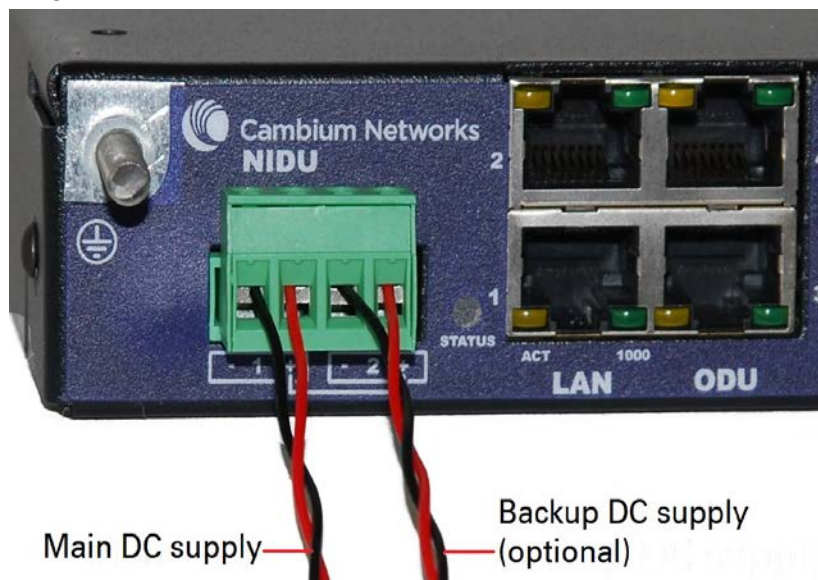



- 3 Connect the main DC supply cable to its power source. If this supply is from the AC+DC Enhanced Power Injector, the DC Out first terminal is negative (black wire) and the second is positive (red wire):

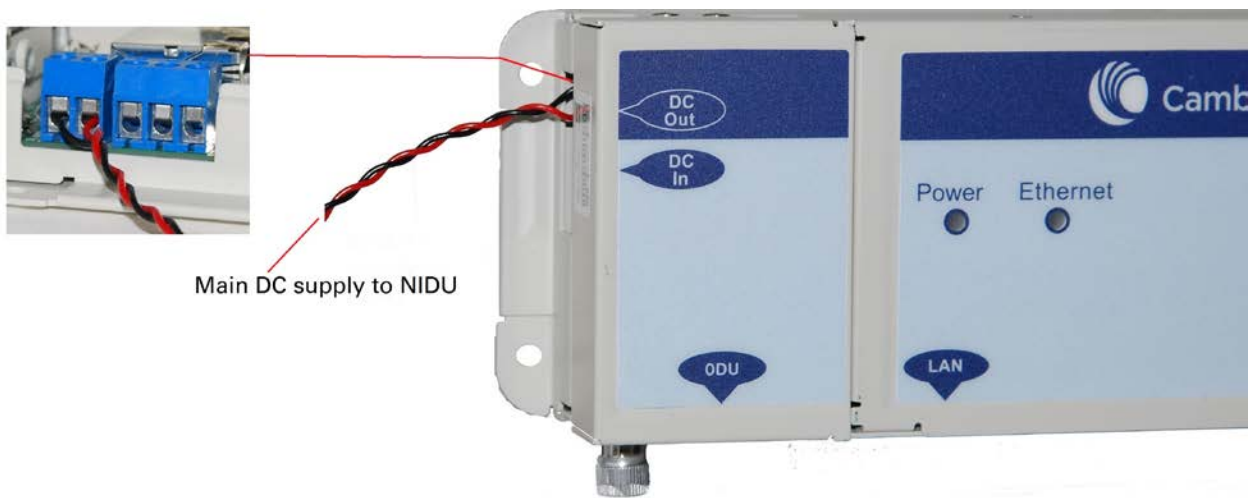

- 4 Connect the backup DC supply cable to its power source.

## Using the PTP 800 AC-DC Power Supply Converter

If a suitable AC mains supply is available, use the PTP 800 AC-DC Power Supply Converter (Cambium part number WB3622) to power the NIDU (Figure 121). This includes a DC power connector that plugs into both ports of the NIDU DC interface.

**Figure 121** NIDU powered by the PTP 800 AC-DC Power Supply Converter



# Installing an SFP Ethernet interface

---

In more advanced configurations, there may be an optical or copper Cat5e Ethernet interface connected to the SFP port of the ODU. Refer to [Typical deployment](#) on page 3-2 for diagrams of these configurations.

Adapt the installation procedures in this chapter as appropriate for SFP interfaces, noting the following differences from a PSU interface:

- Install an optical or copper SFP module in the ODU (SFP port) and connect the SFP optical or copper cable into this module using the long cable gland from the SFP module kit. This is described in the following procedures:
  - [Fitting the long cable gland](#) on page 5-48
  - [Inserting the SFP module](#) on page 5-49
  - [Connecting the cable](#) on page 5-51
  - [Fitting the gland](#) on page 5-52
  - [Removing the cable and SFP module](#) on page 5-54
- Optical cables do not require LPUs or ground cables.
- At the remote end of an SFP drop cable, use an appropriate termination for the connected device.
- If the connected device is outdoors, not in the equipment building or cabinet, adapt the grounding instructions as appropriate.
- PTP 700 LPUs are not suitable for installation on SFP copper Cat5e interfaces. For SFP drop cables, obtain suitable surge protectors from a specialist supplier.
- Ground the top LPUs and surge protector to the same point on the ODU ([Figure 122](#)).

**Figure 122** ODU with copper Cat5e connections to all three Ethernet ports

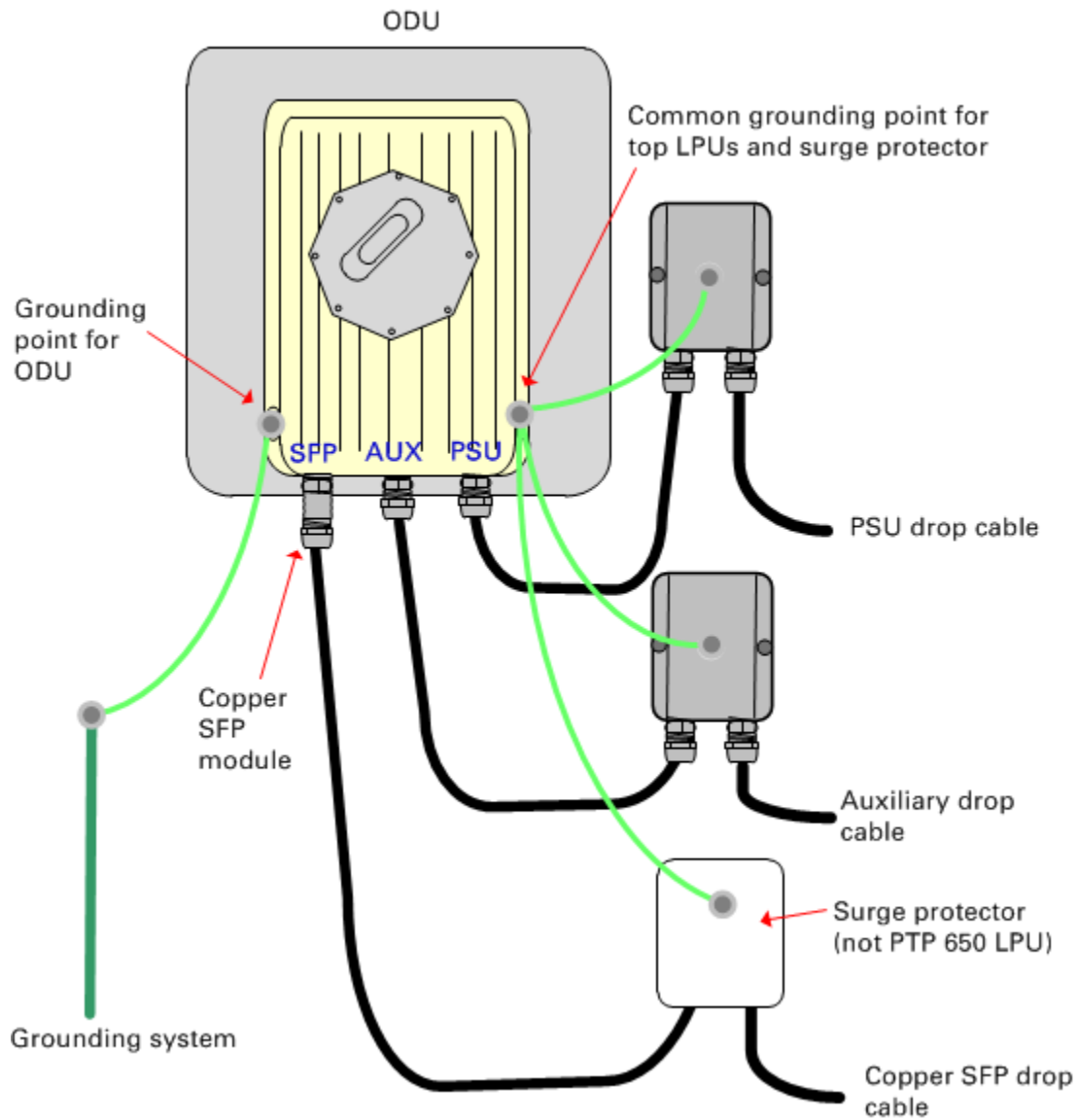



## Fitting the long cable gland

**Optical SFP interface:** Disassemble the long cable gland and thread its components over the LC connector at the ODU end as shown below.

**Copper Cat5e SFP interface:** Disassemble the long cable gland and thread its components over the RJ45 connector at the ODU end as shown below.

- 1 Disassemble the gland:



- 2 Thread each part onto the cable (the rubber bung is split):



- 3 Assemble the spring clip and the rubber bung (the clips go inside the ring):



- 4 Fit the parts into the body and lightly screw on the gland nut (do not tighten it):  
Optical



Copper



## Inserting the SFP module

To insert the SFP module into the ODU, proceed as follows:

- 1 Remove the **blanking plug** from the SFP port of the ODU:



- 2 Insert the SFP module into the SFP receptacle with the label up:

Optical



Copper



- 3 Push the module home until it clicks into place:

Optical



Copper

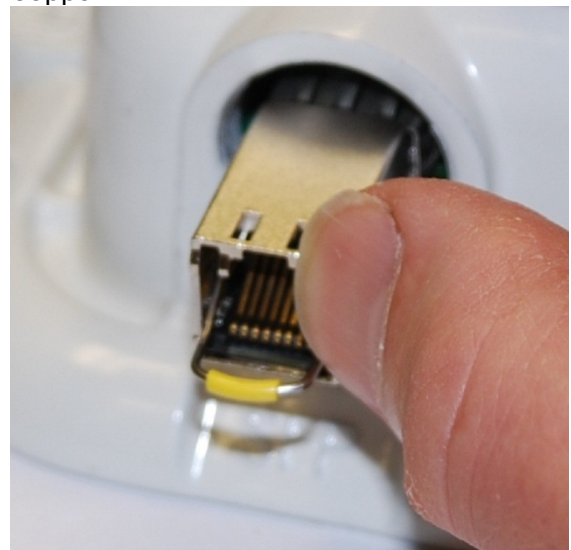

- 4 Rotate the latch to the locked position:

Optical

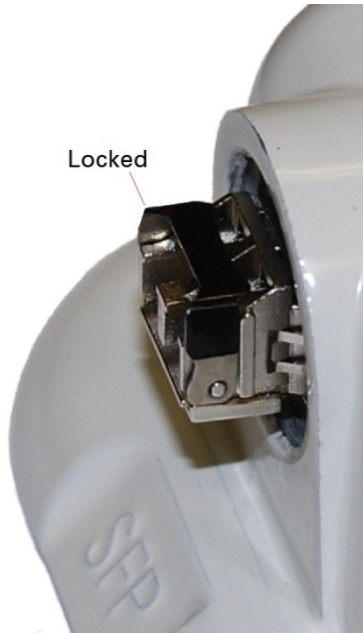

Copper

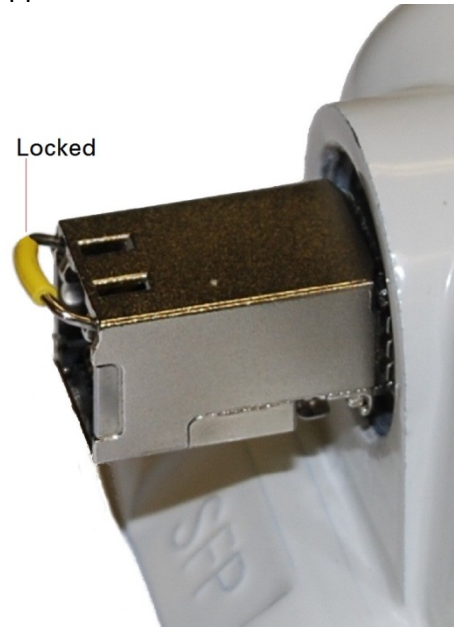

## Connecting the cable



### Caution

The fiber optic cable assembly is very delicate. To avoid damage, handle it with extreme care. Ensure that the fiber optic cable does not twist during assembly, especially when fitting and tightening the weatherproofing gland.

Do not insert the power over Ethernet drop cable from the PSU into the SFP module, as this will damage the module.

- 1 Remove the LC connector dust caps from the ODU end (optical cable only):



- 2 Plug the connector into the SFP module, ensuring that it snaps home:



Optical



Copper



## Fitting the gland

- 1 Fit the gland body to the SFP port and tighten it to a torque of 5.5 Nm (4.3 lb ft)



- 2 Fit the gland nut and tighten until the rubber seal closes on the cable. Do not over-tighten the gland nut, as there is a risk of damage to its internal components:



## Removing the cable and SFP module

Do not attempt to remove the module without disconnecting the cable, otherwise the locking mechanism in the ODU will be damaged.

- 1 Remove the cable connector by pressing its release tab before pulling it out:

Optical

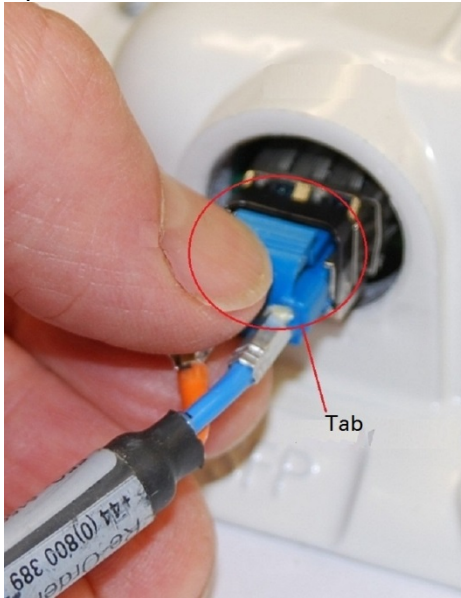

Copper

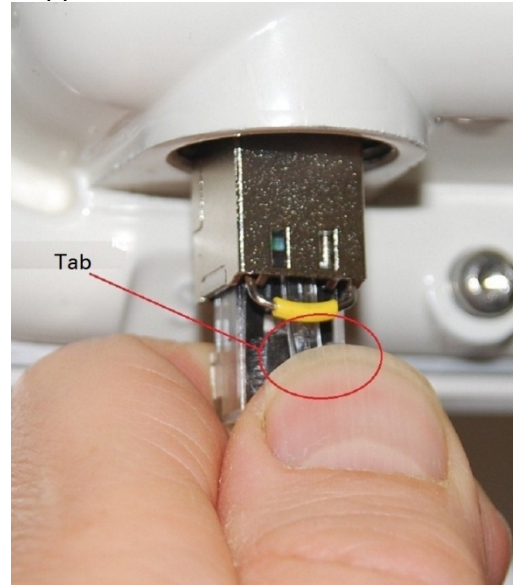

- 2 Rotate the latch to the unlocked position. Extract the module by using a screwdriver:

Optical

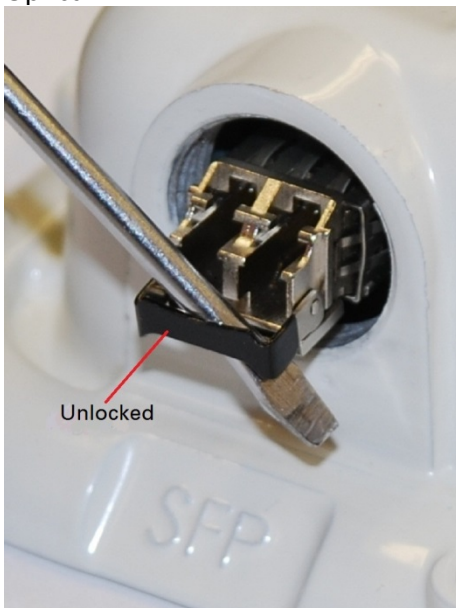

Copper

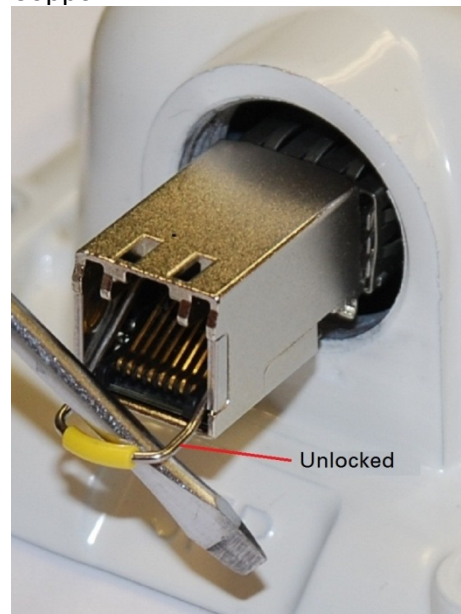



## Installing an Aux Ethernet interface

---

In more advanced configurations, there may be a copper Cat5e Ethernet interface connected to the Aux port of the ODU. Refer to [Typical deployment](#) on page 3-2 for a diagram of this configuration.

Adapt the installation procedures in this chapter as appropriate for the Aux interface, noting the following differences:

- At the remote end of the Aux drop cable, use an appropriate termination for the connected device (for example, a video camera or wireless access point).
- If the connected device is outdoors, not in the equipment building or cabinet, adapt the grounding instructions as appropriate.
- Ground the top LPUs and surge protector to the same point on the ODU ([Figure 122](#)).

## Supplemental installation information

This section contains detailed installation procedures that are not included in the above topics, such as how to strip cables, create grounding points and weatherproof connectors.

### Stripping drop cable

When preparing drop cable for connection to the PTP 700 ODU or LPU, use the following measurements:

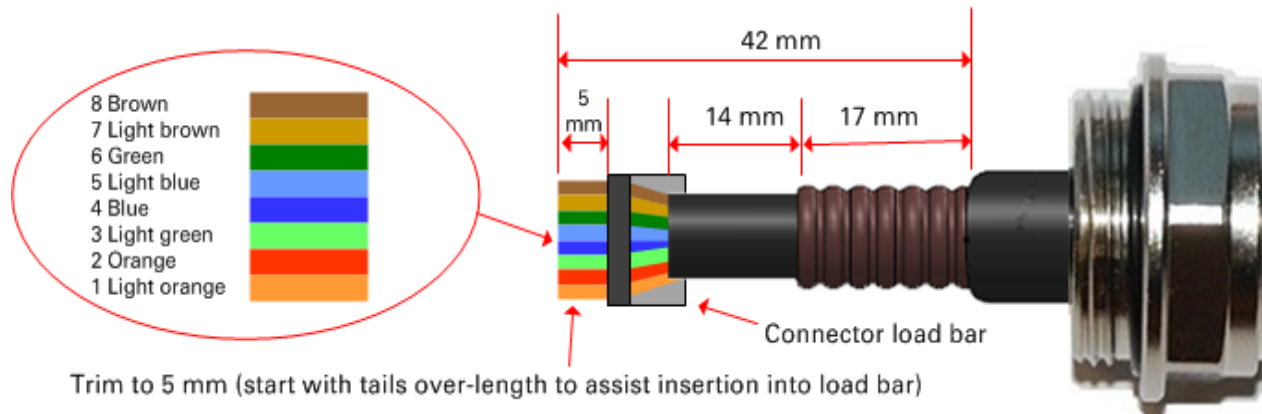

When preparing drop cable for connection to the PTP 700 PSU (without a cable gland), use the following measurements:

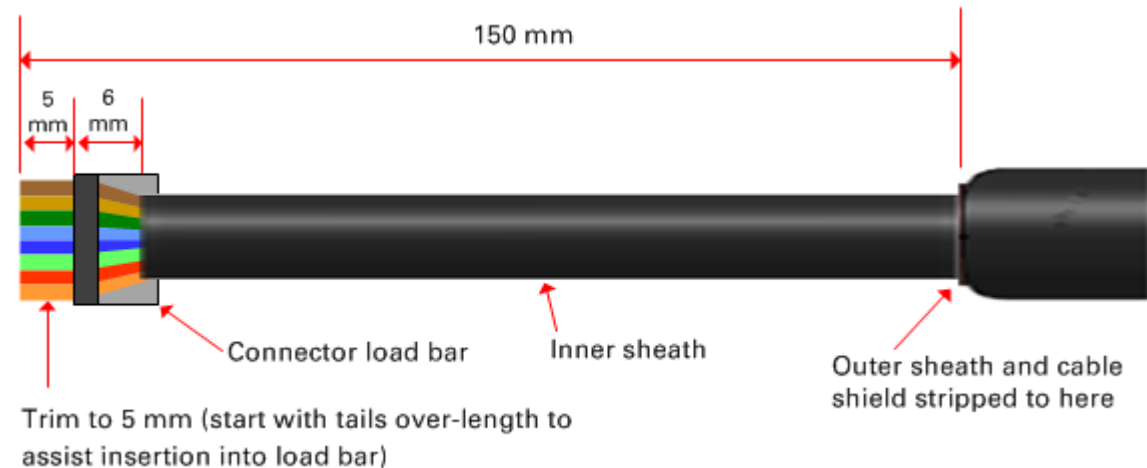

## Creating a drop cable grounding point

Use this procedure to connect the screen of the main drop cable to the metal of the supporting structure using the cable grounding kit (Cambium part number 01010419001).

To identify suitable grounding points, refer to [Drop cable grounding points](#) on page 3-17.

- 1 Remove 60 mm (2.5 inches) of the drop cable outer sheath.



- 2 Cut 38mm (1.5 inches) of rubber tape (self-amalgamating) and fit to the ground cable lug. Wrap the tape completely around the lug and cable.



- 3 Fold the ground wire strap around the drop cable screen and fit cable ties.



- 4 Tighten the cable ties with pliers. Cut the surplus from the cable ties.



- 5 Cut a 38mm (1.5 inches) section of self-amalgamating tape and wrap it completely around the joint between the drop and ground cables.



- 6 Use the remainder of the self-amalgamating tape to wrap the complete assembly. Press the tape edges together so that there are no gaps.





- 7 Wrap a layer of PVC tape from bottom to top, starting from 25 mm (1 inch) below and finishing 25 mm (1 inch) above the edge of the self-amalgamating tape, over lapping at half width.



- 8 Repeat with a further four layers of PVC tape, always overlapping at half width. Wrap the layers in alternate directions (top to bottom, then bottom to top). The edges of each layer should be 25mm (1 inch) above (A) and 25 mm (1 inch) below (B) the previous layer.



- 9 Prepare the metal grounding point of the supporting structure to provide a good electrical contact with the grounding cable clamp. Remove paint, grease or dirt, if present. Apply anti-oxidant compound liberally between the two metals.

- 10 Clamp the bottom lug of the grounding cable to the supporting structure using site approved methods. Use a two-hole lug secured with fasteners in both holes. This provides better protection than a single-hole lug.

## Weatherproofing an N type connector

Use this procedure to weatherproof the N type connectors fitted to the connectorized ODU and external antenna (if recommended by the antenna manufacturer).

- 1 Ensure the connection is tight. A torque wrench should be used if available:

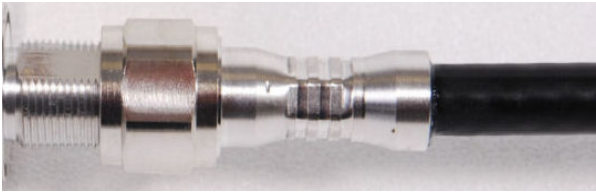

- 2 Wrap the connection with a layer of 19 mm (0.75 inch) PVC tape, starting 25 mm (1 inch) below the connector body. Overlap the tape to half-width and extend the wrapping to the body of the LPU. Avoid making creases or wrinkles:

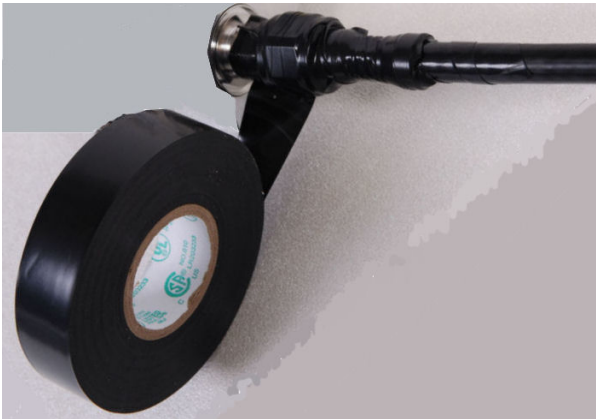

- 3 Smooth the tape edges:



- 4** Cut a 125mm (5 inches) length of rubber tape (self-amalgamating):

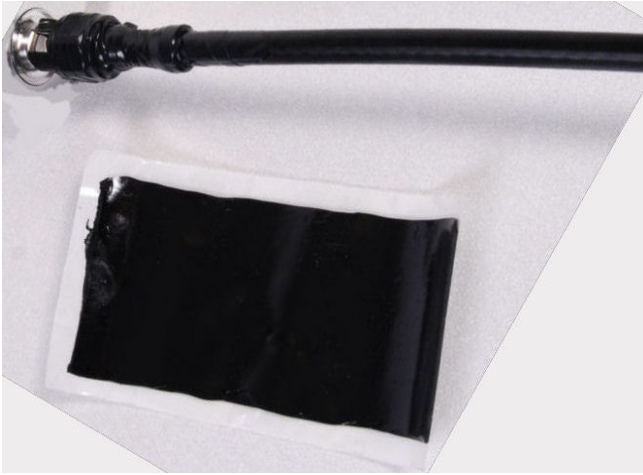

- 5** Expand the width of the tape by stretching it so that it will wrap completely around the connector and cable:



- 6** Press the tape edges together so that there are no gaps. The tape should extend 25 mm (1 inch) beyond the PVC tape:



- 7** Wrap a layer of 50 mm (2 inch) PVC tape from bottom to top, starting from 25 mm (1 inch) below the edge of the self-amalgamating tape, overlapping at half width.

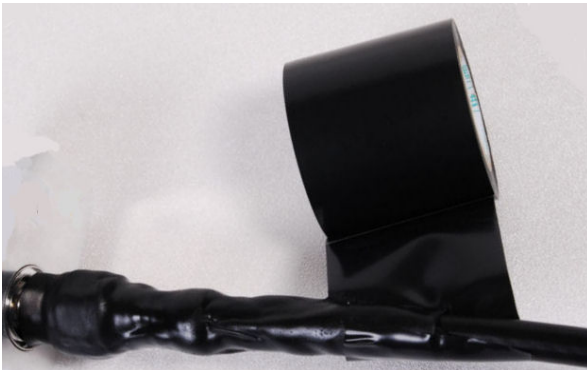



- 8** Repeat with a further four layers of 19 mm (0.75 inch) PVC tape, always overlapping at half width. Wrap the layers in alternate directions:
- Second layer: top to bottom.
  - Third layer: bottom to top.
  - Fourth layer: top to bottom.
  - Fifth layer: bottom to top.

The bottom edge of each layer should be 25 mm (1 inch) below the previous layer.



- 9** Check the completed weatherproof connection:



## Replacing PSU fuses

The AC+ DC Enhanced Power Injector contains two replaceable fuses. These fuses protect the positive and negative grounded DC input voltages. If an incorrect power supply (that is, not in the range 37V to 60V DC) is connected to the DC input terminals, one or both fuses may blow.

Both fuses are 3 Amp slow-blow, for example Littlefuse part number 0229003.

To replace these fuses, undo the retaining screw and hinge back the cover as indicated:



### Note

No other fuses are replaceable in the AC+DC Enhanced Power Injector.