

EMC TEST REPORT

Report No. : EME-060555
Model No. : BTD-43X, LM058
Issued Date : Sep. 13, 2006

Applicant : Rayson Technology Co., Ltd.
1F, No. 9, R&D. II, SBIP, Hsin-Chu, Taiwan

Test By : Intertek Testing Services Taiwan Ltd.
No. 11, Lane 275, Ko-Nan 1 Street, Chia-Tung Li,
Shiang-Shan District, Hsinchu City, Taiwan

This test report consists of 86 pages in total. It may be duplicated completely for legal use with the allowance of the applicant. It shall not be reproduced except in full, without the written approval of Intertek Laboratory. The test result(s) in this report only applies to the tested sample(s).

Project Engineer

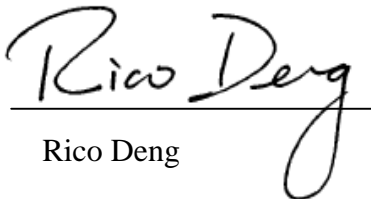
Rico Deng

Reviewed By



Jerry Liu

Table of Contents

Summary of Tests.....	4
1. General information	5
1.1 Identification of the EUT	5
1.2 Additional information about the EUT.....	5
1.3 Antenna description.....	6
1.4 Peripherals equipment	6
2. Test specifications	7
2.1 Test standard.....	7
2.2 Operation mode	7
2.3 Test equipment	8
3. 20dB Bandwidth test	9
3.1 Operating environment.....	9
3.2 Test setup & procedure.....	9
3.3 Measured data of modulated bandwidth test results	9
4. Carrier Frequency Separation test	13
4.1 Operating environment.....	13
4.2 Test setup & procedure.....	13
4.3 Measured data of Carrier Frequency Separation test result	13
5. Number of hopping frequencies test	17
5.1 Operating environment.....	17
5.2 Test setup & procedure.....	17
5.3 Measured data of number of hopping frequencies test result.....	17
6. Time of Occupancy (dwell time) test	21
6.1 Operating environment.....	21
6.2 Test setup & procedure.....	21
7. Maximum Output Power test	32
7.1 Operating environment.....	32
7.2 Test setup & procedure.....	32
7.3 Measured data of Maximum Output Power test results	32
8. RF Antenna Conducted Spurious test.....	34
8.1 Operating environment.....	34
8.2 Test setup & procedure.....	34

- 8.3 Measured data of the highest RF Antenna Conducted Spurious test result34
- 9. Radiated Emission test62
 - 9.1 Operating environment.....62
 - 9.2 Test setup & procedure.....62
 - 9.3 Emission limits.....63
 - 9.4 Radiated spurious emission test data.....64
 - 9.4.1 Measurement results: frequencies equal to or less than 1 GHz.....64
 - 9.4.2 Measurement results: frequency above 1GHz65
- 10. Emission on the band edge.....68
 - 10.1 Operating environment.....68
 - 10.2 Test setup & procedure.....68
 - 10.3 Test Result69
 - 10.3.1 Conducted Method69
 - 10.3.2 Radiated Method81
- 11. Conducted Emission Measurements (FCC 15.107)83
 - 11.1 Operating environment.....83
 - 11.2 Test Setup and procedure.....83
 - 11.3 Test Equipment84
 - 11.4 Conducted Emission Limits:84
 - 11.5 Uncertainty of Conducted Emission.....84
 - 11.6 Conducted Emission Data85

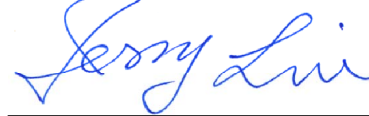
Summary of Tests**Bluetooth Serial Adapter-Model: BTD-430
FCC ID: QWOBTD-430**

Test	Reference	Results
Maximum Output Power test	15.247(b)	Pass
Carrier Frequency Separation test	15.247(a)(1)	Pass
Number of hopping frequencies test	15.247(a)(1)	Pass
Time of Occupancy (dwell time) test	15.247(a)(1)	Pass
20dB Bandwidth test	15.247(a)(1)	Pass
Radiated Spurious Emission test	15.205, 15.209	Pass
Emission on the Band Edge test	15.247(d)	Pass
AC Power Line Conducted Emission test	15.207	Pass

1. General information

1.1 Identification of the EUT

Applicant	: Rayson Technology Co., Ltd.
Product	: Bluetooth Serial Adaptor
Model No.	: BTD-430
FCC ID.	: QWOBTD-430
Frequency Range	: 2402MHz ~ 2480MHz
Channel Number	: 78 channels
Frequency of Each Channel	: 2402 + k MHz; k = 0-78
Type of Modulation	: GFSK, DQPSK, 8DPSK
Rated Power	: DC 6V from Adapter (Model No.DSA-5P-05)
Power Cord	: N/A
Sample Received	: May 11, 2006
Test Date(s)	: May 11, 2006 ~ Sep. 11, 2006

A FCC DoC report has been generated for the client.

1.2 Additional information about the EUT

The EUT is a Bluetooth Serial Adaptor, and was defined as information technology equipment.

The models BTD-43X (X = 0, 1, 2, 3, 4,5, 6, 7, 8, 9) and LM058 are identical to model BTD-430 (EUT), the different model number for different marketing strategy.

For more detail features, please refer to User's manual as file name "Installation guide.pdf"

1.3 Antenna description

The antenna is affixed to the EUT using a unique connector, which allows for replacement of a broken antenna, but DOES NOT use a standard antenna jack or electrical connector.

Antenna Gain : 2dBi max

Antenna Type : Dipole antenna

Connector Type : SMA Reverse

1.4 Peripherals equipment

Peripherals	Manufacturer	Product No.	Serial No.	FCC ID
Notebook PC	DELL	PP05L	CN-5G5152-48643-498-6810	E2K24GBRL

2. Test specifications

2.1 Test standard

The EUT was performed according to the procedures in FCC Part 15 Subpart C Section § 15.205, §15.207, §15.209, §15.247 and ANSI C63.4/2003.

The test of radiated measurements according to FCC Part15 Section 15.33(a) had been conducted and the field strength of this frequency band were all meet limit requirement, thus we evaluate the EUT pass the specified test.

2.2 Operation mode

The EUT was supplied with 5Vdc from Notebook PC and it was running in operating mode.

The EUT was transmitted continuously during the test.

2.3 Test equipment

Equipment	Brand	Frequency range	Model No.	Intertek ID No.	Next Cal. Date
EMI Test Receiver	Rohde & Schwarz	9kHz~2.75GHz	ESCS 30	EC303	08/08/2007
EMI Test Receiver	Rohde & Schwarz	20Hz~26.5GHz	ESMI	EC317	08/07/2007
Spectrum Analyzer	Rohde & Schwarz	9kHz~30GHz	FSP 30	EC353	07/24/2007
Spectrum Analyzer	Rohde & Schwarz	20Hz~40GHz	FSEK 30	EC365	11/01/2006
Horn Antenna	SCHWARZBECK	1GHz~18GHz	BBHA 9120 D	EC371	02/19/2007
Horn Antenna	SCHWARZBECK	14GHz~40GHz	BBHA 9170	EC351	07/08/2007
Bilog Antenna	SCHWARZBECK	25MHz~2GHz	VULB 9168	EC347	03/20/2007
Pre-Amplifier	MITEQ	100MHz~26.5GHz	919981	EC373	2/13/2007
Pre-Amplifier	MITEQ	26GHz~40GHz	828825	EC374	01/15/2007
Wideband Peak Power Meter/ Sensor	Anritsu	100MHz~18GHz	ML2497A/ MA2491A	EC396	11/10/2006
Controller	HDGmbH	N/A	CM 100	EP346	N/A
Antenna Tower	HDGmbH	N/A	MA 240	EP347	N/A
LISN	Rohde & Schwarz	9KHz~30MHz	ESH3-Z5	EC344	01/15/2007

- Note: 1. The above equipments are within the valid calibration period.
 2. The test antennas (receiving antenna) are calibration per 1 year.

3. 20dB Bandwidth test

3.1 Operating environment

Temperature: 25
Relative Humidity: 55 %
Atmospheric Pressure: 1023 hPa

3.2 Test setup & procedure

The 20dB bandwidth per FCC §15.247(a)(1) was measured using a 50 ohm spectrum analyzer with the resolutions bandwidth set at 100 kHz, the video bandwidth RBW, and the SPAN may equal to approximately 2 to 3 times the 20dB bandwidth. The test was performed at 3 channels (lowest, middle and highest channel). The maximum 20dB modulation bandwidth is in the following Table.

3.3 Measured data of modulated bandwidth test results

Test Mode: GFSK

Channel	Frequency (MHz)	Bandwidth (kHz)
39	2441.00	826.653

Test Mode: DQPSK

Channel	Frequency (MHz)	Bandwidth (kHz)
39	2441.00	1267.535

Test Mode: 8DPSK

Channel	Frequency (MHz)	Bandwidth (kHz)
39	2441.00	1297.595

Please see the plot below.

Test mode: GFSK

	Marker 1 [T1 ndB]	RBW	30 kHz	RF Att	20 dB
	Ref Lvl	ndB	20.00 dB	VBW	100 kHz
	31.5 dBm	BW	826.65330661 kHz	SWT	7 ms
				Unit	dBm

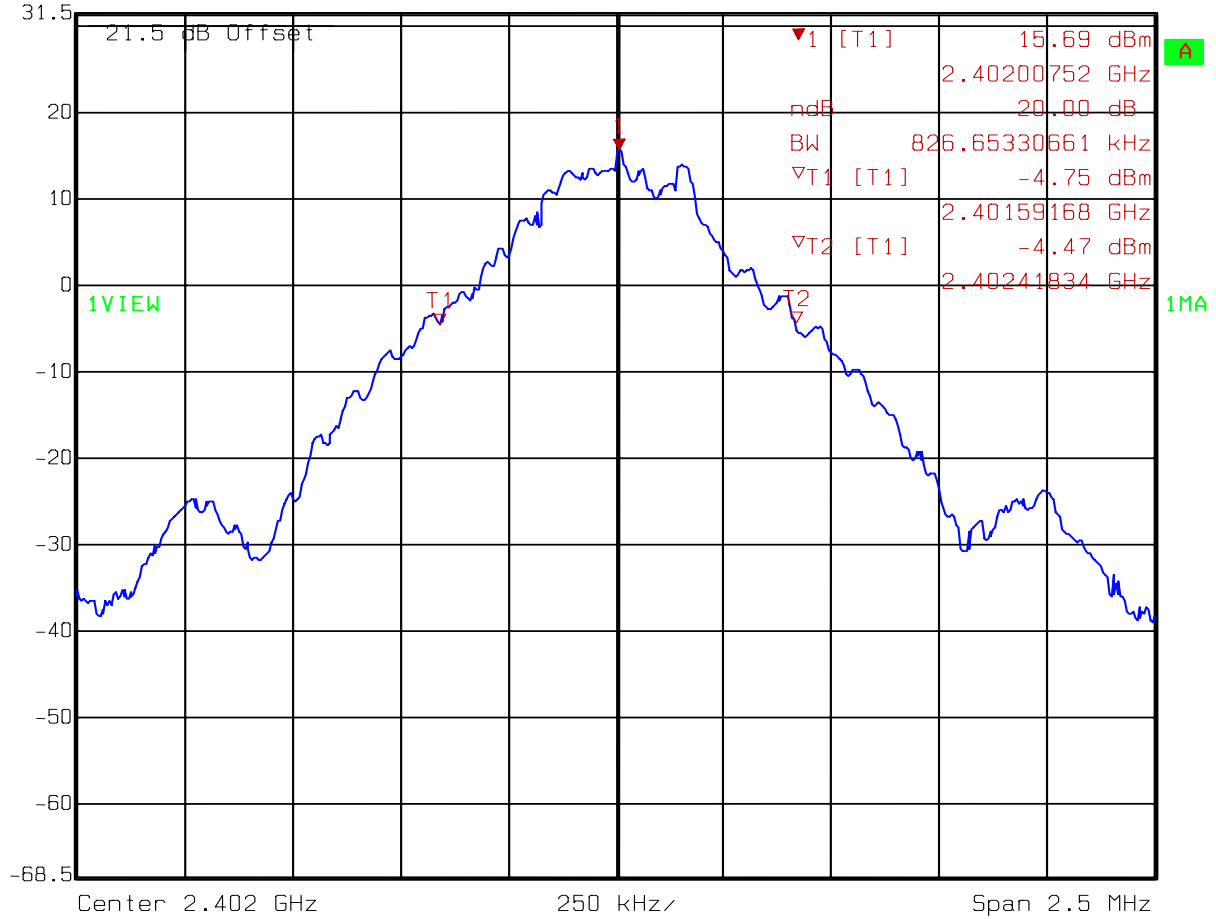

Comment A: 20dB Bandwidth for GFSK
Date: 11.MAY 2006 14:45:35

Test mode: DQPSK

	Ref Lvl	31.5 dBm	Marker 1 [T1 ndB]	20.00 dB	RBW	30 kHz	RF Att	20 dB
			BW	1.26753507 MHz	VBW	100 kHz	SWT	7 ms
							Unit	dBm

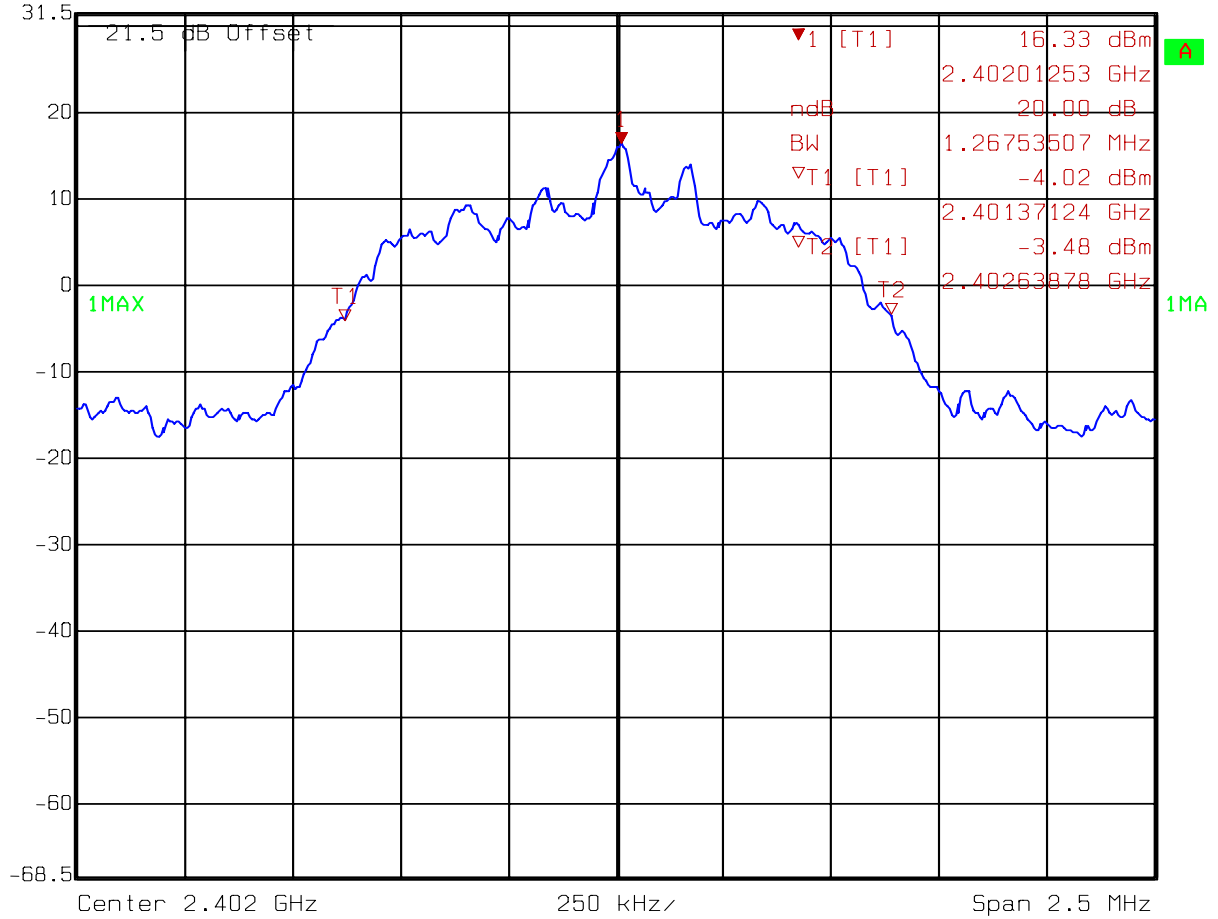

Comment A: 20dB Bandwidth for DQPSK
Date: 11.MAY 2006 14:48:48

Test mode: 8DPSK

	Marker 1 [T1 ndB]	RBW	30 kHz	RF Att	20 dB
	Ref Lvl	ndB	20.00 dB	VBW	100 kHz
	31.5 dBm	BW	1.29759519 MHz	SWT	7 ms
				Unit	dBm

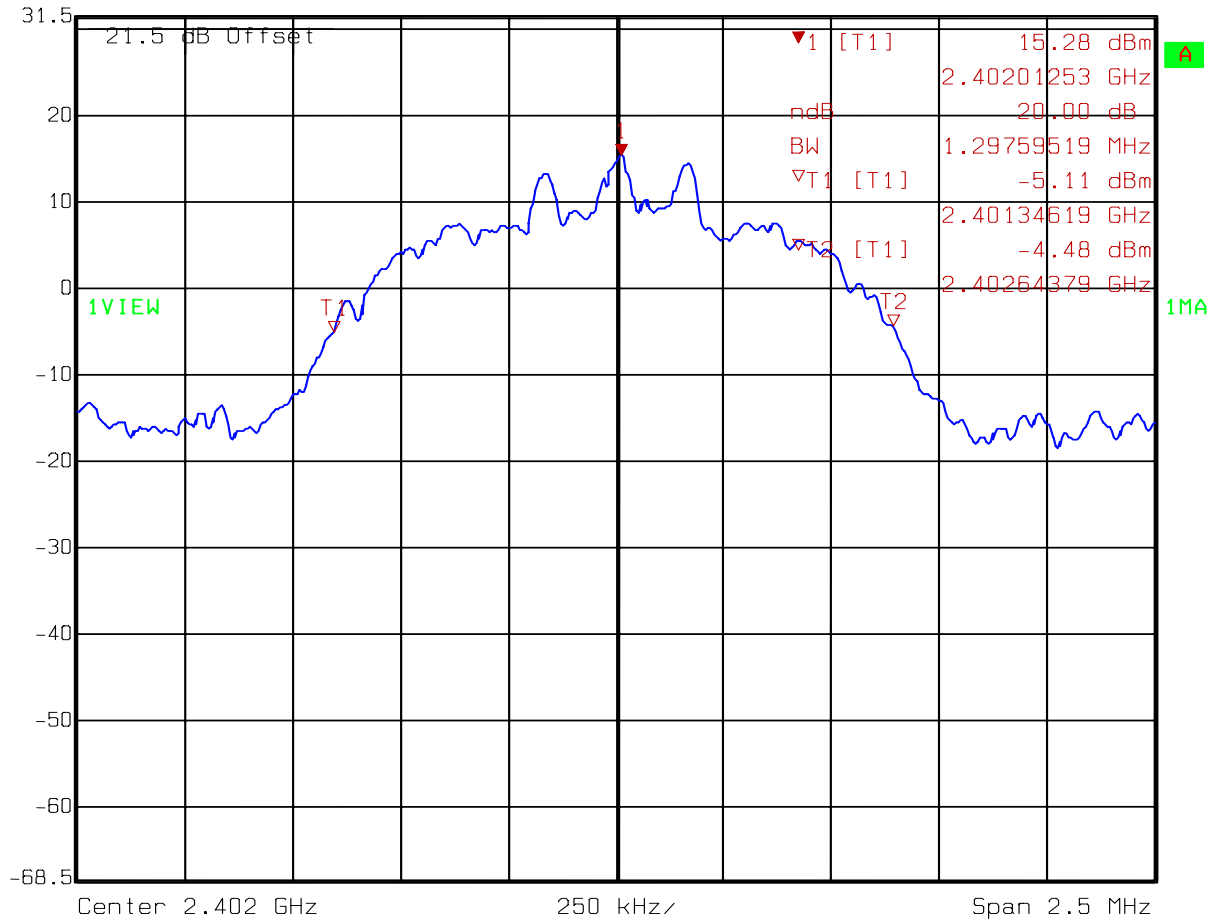

Comment A: 20dB Bandwidth for 8DPSK
 Date: 11.MAY 2006 14:50:52

4. Carrier Frequency Separation test

4.1 Operating environment

Temperature: 25
 Relative Humidity: 55 %
 Atmospheric Pressure: 1023 hPa

4.2 Test setup & procedure

The carrier frequency separation per FCC §15.247(a)(1) was measured using a 50 ohm spectrum analyzer with the resolutions bandwidth set at 1 % of the span, the video bandwidth RBW, and the SPAN was wide enough to capture the peaks of two adjacent channels. The carrier frequency separation result is in the following Table.

4.3 Measured data of Carrier Frequency Separation test result

Test mode: GFSK

Channel	Frequency (MHz)	Measurement Frequency separation (kHz)
0	2402	1006.012
1	2403	

Test mode: DQPSK

Channel	Frequency (MHz)	Measurement Frequency separation (kHz)
0	2402	1002.004
1	2403	

Test mode: 8DPSK

Channel	Frequency (MHz)	Measurement Frequency separation (kHz)
0	2402	1002.004
1	2403	

Please see the plot below.

Test mode: 8DPSK

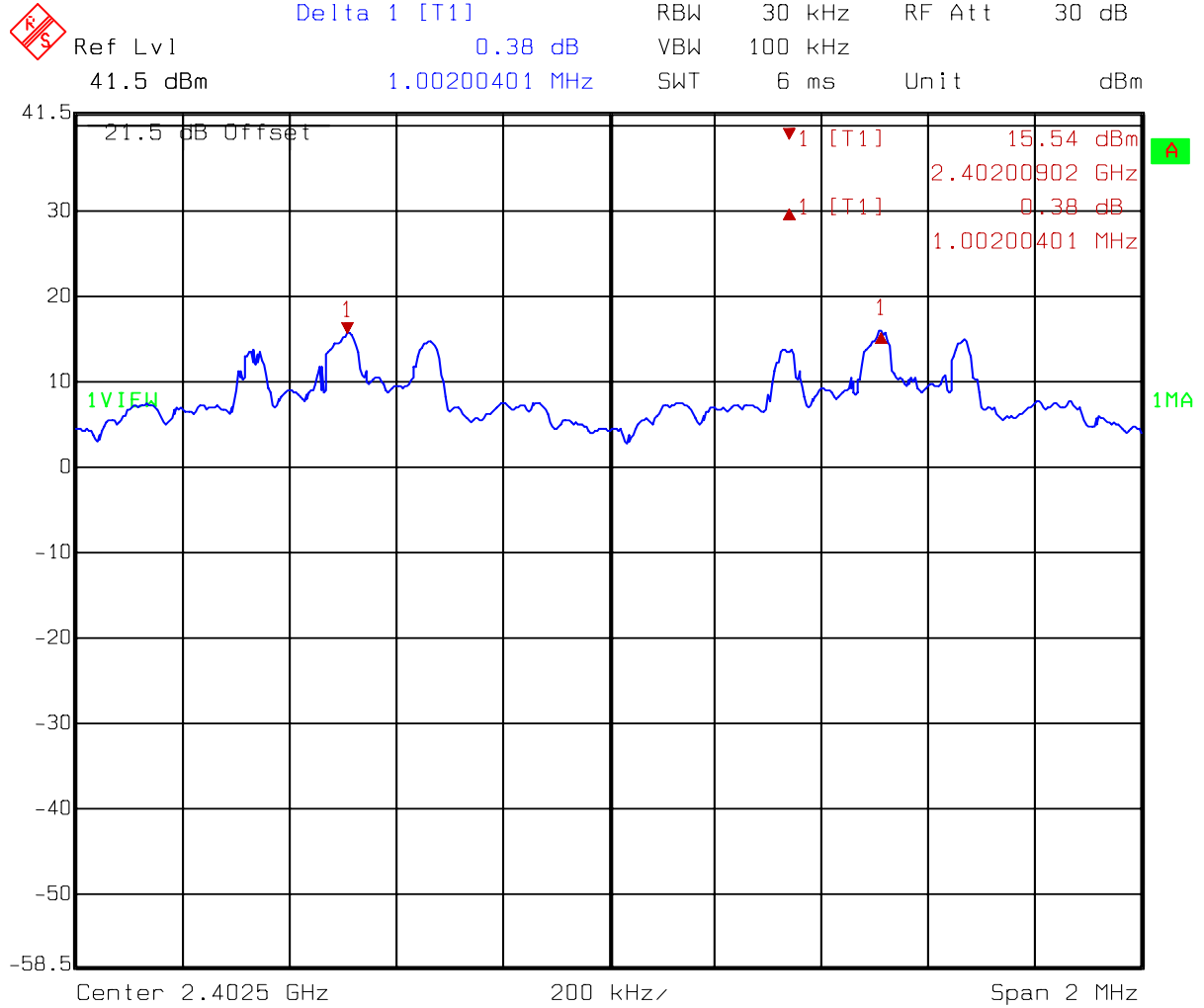

Comment A: Carrier frequencies separation between ch0 and ch1
8DPSK

Date: 11.MAY 2006 16:56:10

5. Number of hopping frequencies test

5.1 Operating environment

Temperature: 25
 Relative Humidity: 55 %
 Atmospheric Pressure: 1023 hPa

5.2 Test setup & procedure

The number of hopping frequencies per FCC §15.247(a)(1) was measured using a 50 ohm spectrum analyzer with the resolutions bandwidth set at 1 % of the span, the video bandwidth RBW, and the SPAN was the frequency band of operation. The carrier frequency separation result is in the following Table.

5.3 Measured data of number of hopping frequencies test result

Test mode: Test mode: 8DPSK

Frequency Range (MHz)	Total hopping channels
2400 ~ 2483.5	79

Test mode: Test mode: GFSK

Frequency Range (MHz)	Total hopping channels
2400 ~ 2483.5	79

Test mode: Test mode: DQPSK

Frequency Range (MHz)	Total hopping channels
2400 ~ 2483.5	79

Please see the plot below.

Test mode: GFSK

 Ref Lvl 31.5 dBm RBW 100 kHz RF Att 20 dB
VBW 100 kHz
SWT 21 ms Unit dBm

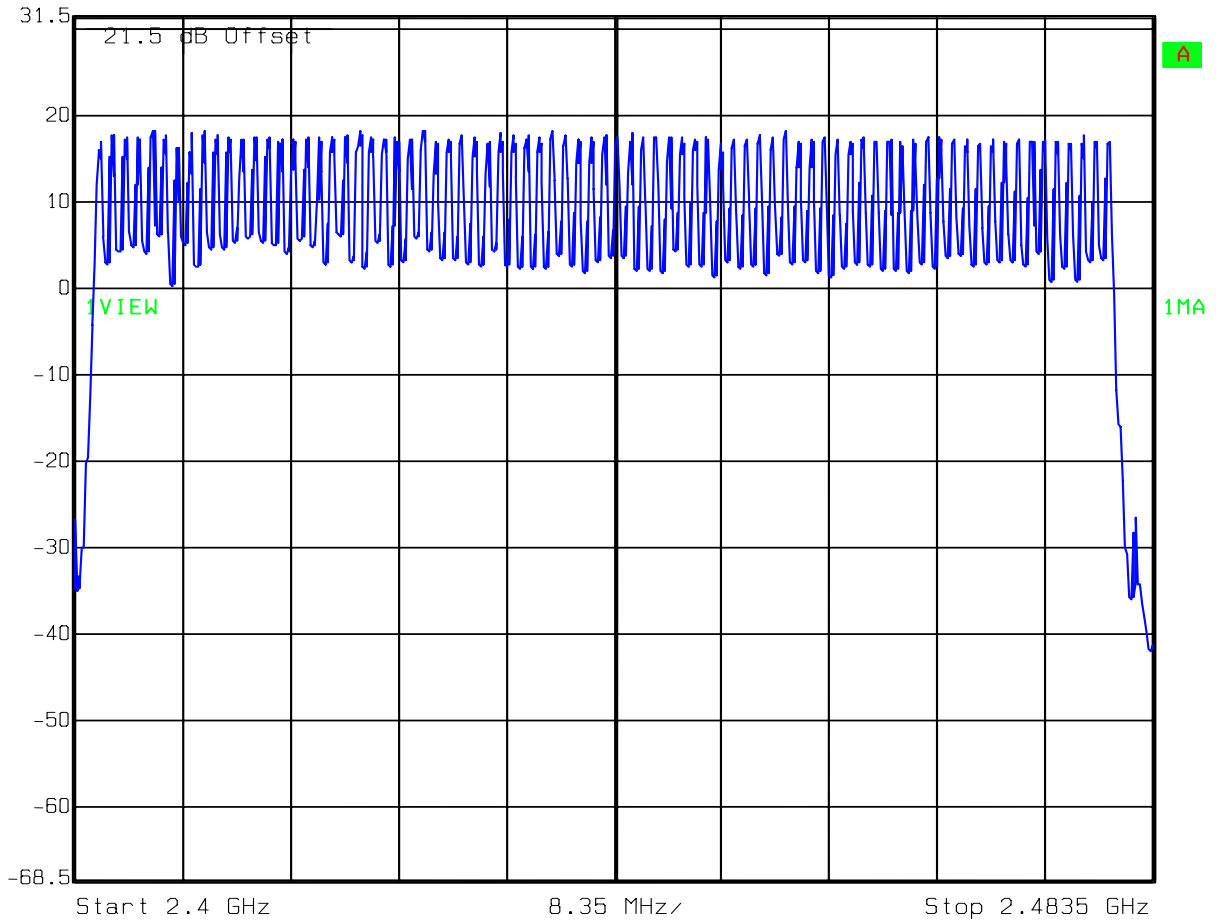

Comment A: No. of hopping channel for GFSK
Date: 11.MAY 2006 15:10:13

Test mode: DQPSK

	Ref Lvl	RBW	100 kHz	RF Att	20 dB
	31.5 dBm	VBW	100 kHz	Unit	dBm
		SWT	21 ms		

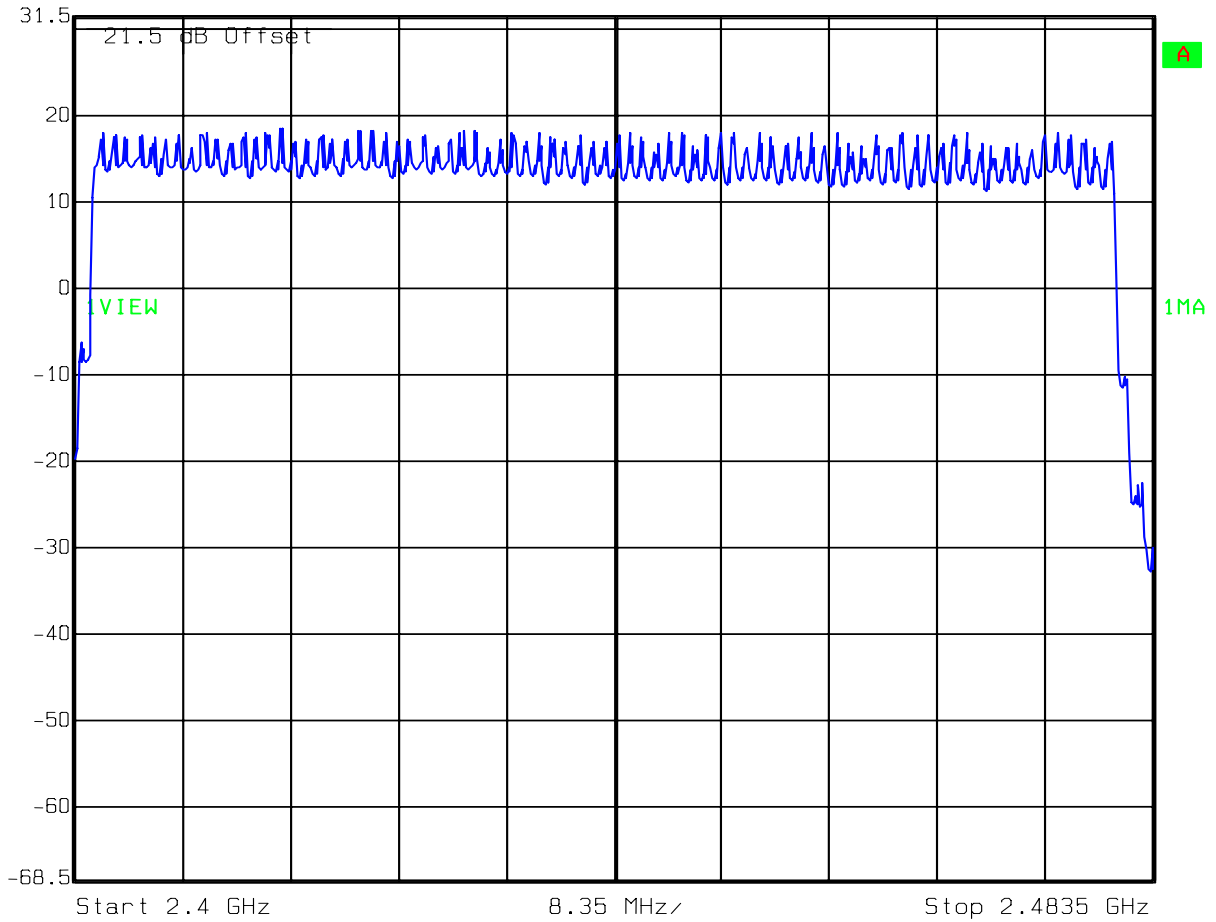

Comment A: No. of hopping channel for DQPSK
Date: 11.MAY 2006 15:17:06

Test mode: 8DPSK



Ref Lvl
31.5 dBm

RBW	100 kHz	RF Att	20 dB
VBW	100 kHz	Unit	dBm
SWT	21 ms		

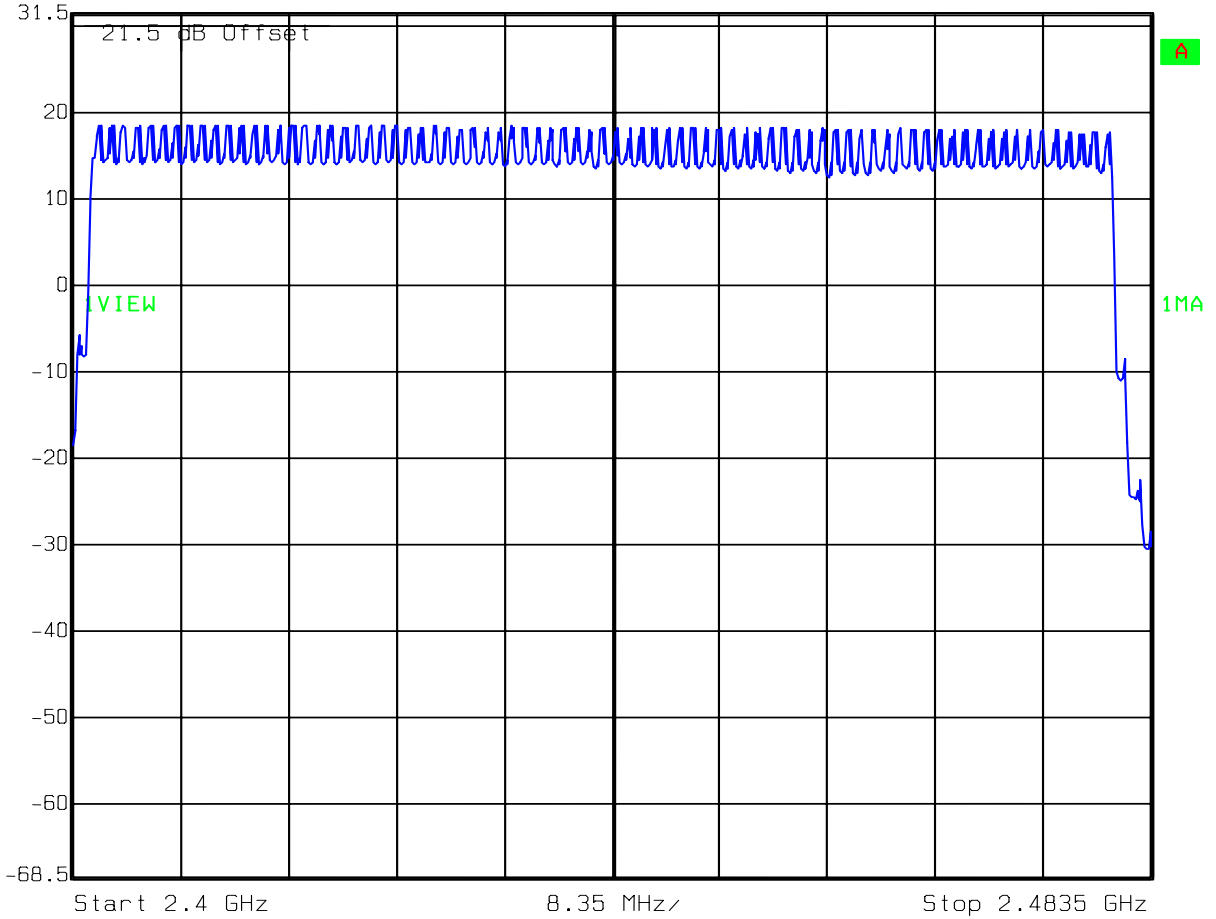

Comment A: No. of hopping channel for 8DPSK
Date: 11.MAY 2006 15:46:32

6. Time of Occupancy (dwell time) test

6.1 Operating environment

Temperature: 25
Relative Humidity: 55 %
Atmospheric Pressure: 1023 hPa

6.2 Test setup & procedure

The time of occupancy (dwell time) per FCC §15.247(a)(1) was measured using a 50 ohm spectrum analyzer with the resolutions bandwidth set at 1MHz, the video bandwidth RBW, and the zero span function of spectrum analyzer was enable. The EUT has its hopping function enable.

The system makes worst case 1600 hops per second or 1 time slot has a length of 625 μ s with 79 channels.

Test mode: GFSK

Time of occupancy (dwell time) for DH1

$$\begin{aligned} \text{Dwell time} &= 406.814 \mu\text{s} * 1600 * 1/2 * 1/\text{s} / 79 * 31.6\text{s} \\ &= 130.180 \text{ ms (in a 31.6s period)} \end{aligned}$$

Time of occupancy (dwell time) for DH3

$$\begin{aligned} \text{Dwell time} &= 1.651 \text{ ms} * 1600 * 1/4 * 1/\text{s} / 79 * 31.6\text{s} \\ &= 264.160 \text{ ms (in a 31.6s period)} \end{aligned}$$

Time of occupancy (dwell time) for DH5

$$\begin{aligned} \text{Dwell time} &= 2.906 \text{ ms} * 1600 * 1/6 * 1/\text{s} / 79 * 31.6\text{s} \\ &= 309.973 \text{ ms (in a 31.6s period)} \end{aligned}$$

Test mode: DQPSK

Time of occupancy (dwell time) for DH1

$$\begin{aligned} \text{Dwell time} &= 422.846 \mu\text{s} * 1600 * 1/2 * 1/s / 79 * 31.6\text{s} \\ &= 135.311 \text{ ms (in a 31.6s period)} \end{aligned}$$

Time of occupancy (dwell time) for DH3

$$\begin{aligned} \text{Dwell time} &= 1.65 \text{ ms} * 1600 * 1/4 * 1/s / 79 * 31.6\text{s} \\ &= 264.000 \text{ ms (in a 31.6s period)} \end{aligned}$$

Time of occupancy (dwell time) for DH5

$$\begin{aligned} \text{Dwell time} &= 2.898 \text{ ms} * 1600 * 1/6 * 1/s / 79 * 31.6\text{s} \\ &= 309.120 \text{ ms (in a 31.6s period)} \end{aligned}$$

Test mode: 8DPSK

Time of occupancy (dwell time) for DH1

$$\begin{aligned} \text{Dwell time} &= 424.850 \mu\text{s} * 1600 * 1/2 * 1/s / 79 * 31.6\text{s} \\ &= 135.952 \text{ ms (in a 31.6s period)} \end{aligned}$$

Time of occupancy (dwell time) for DH3

$$\begin{aligned} \text{Dwell time} &= 1.663 \text{ ms} * 1600 * 1/4 * 1/s / 79 * 31.6\text{s} \\ &= 266.080 \text{ ms (in a 31.6s period)} \end{aligned}$$

Time of occupancy (dwell time) for DH5

$$\begin{aligned} \text{Dwell time} &= 2.916 \text{ ms} * 1600 * 1/6 * 1/s / 79 * 31.6\text{s} \\ &= 311.040 \text{ ms (in a 31.6s period)} \end{aligned}$$

Please see the plot below.

Test mode: GFSK at DH1

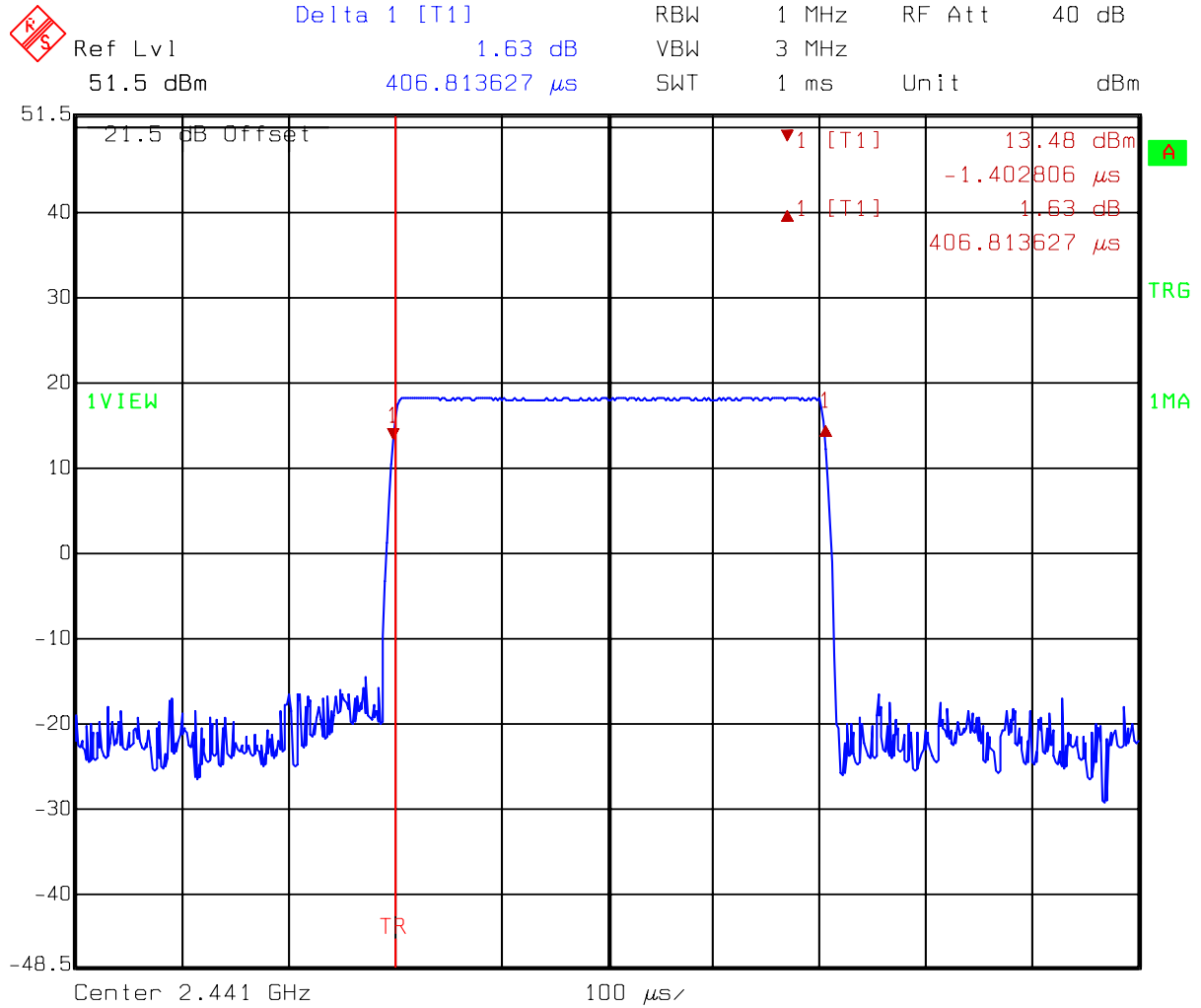

Comment A: Dwell Time at DH1
GFSK

Date: 11.MAY 2006 17:29:16

Test mode: GFSK at DH3

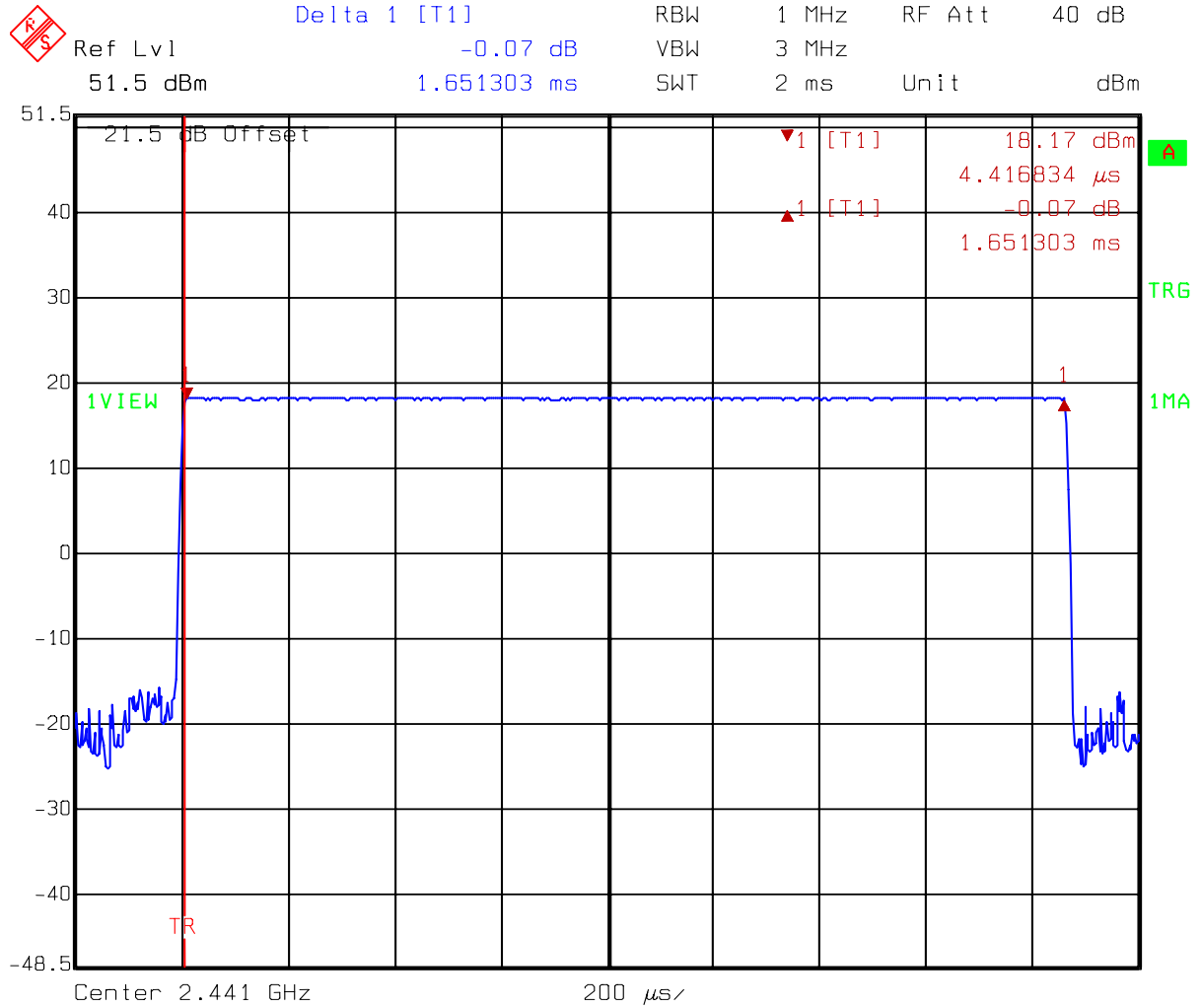

Comment A: Dwell Time at DH3
GFSK
Date: 11.MAY 2006 17:32:22

Test mode: GFSK at DH5

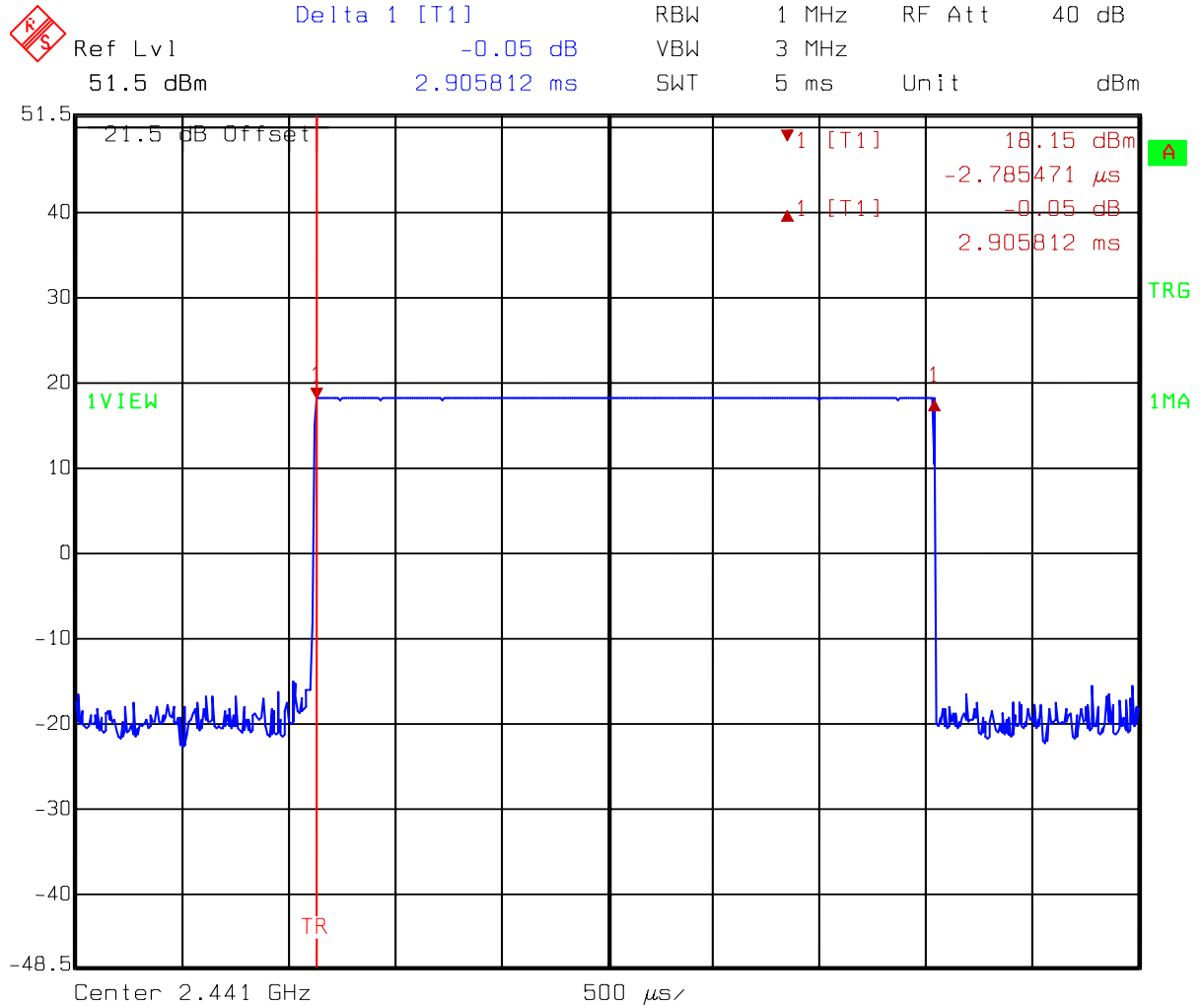

Comment A: Dwell Time at DH5
 GFSK
 Date: 11.MAY 2006 17:38:05

Test mode: DQPSK at DH3

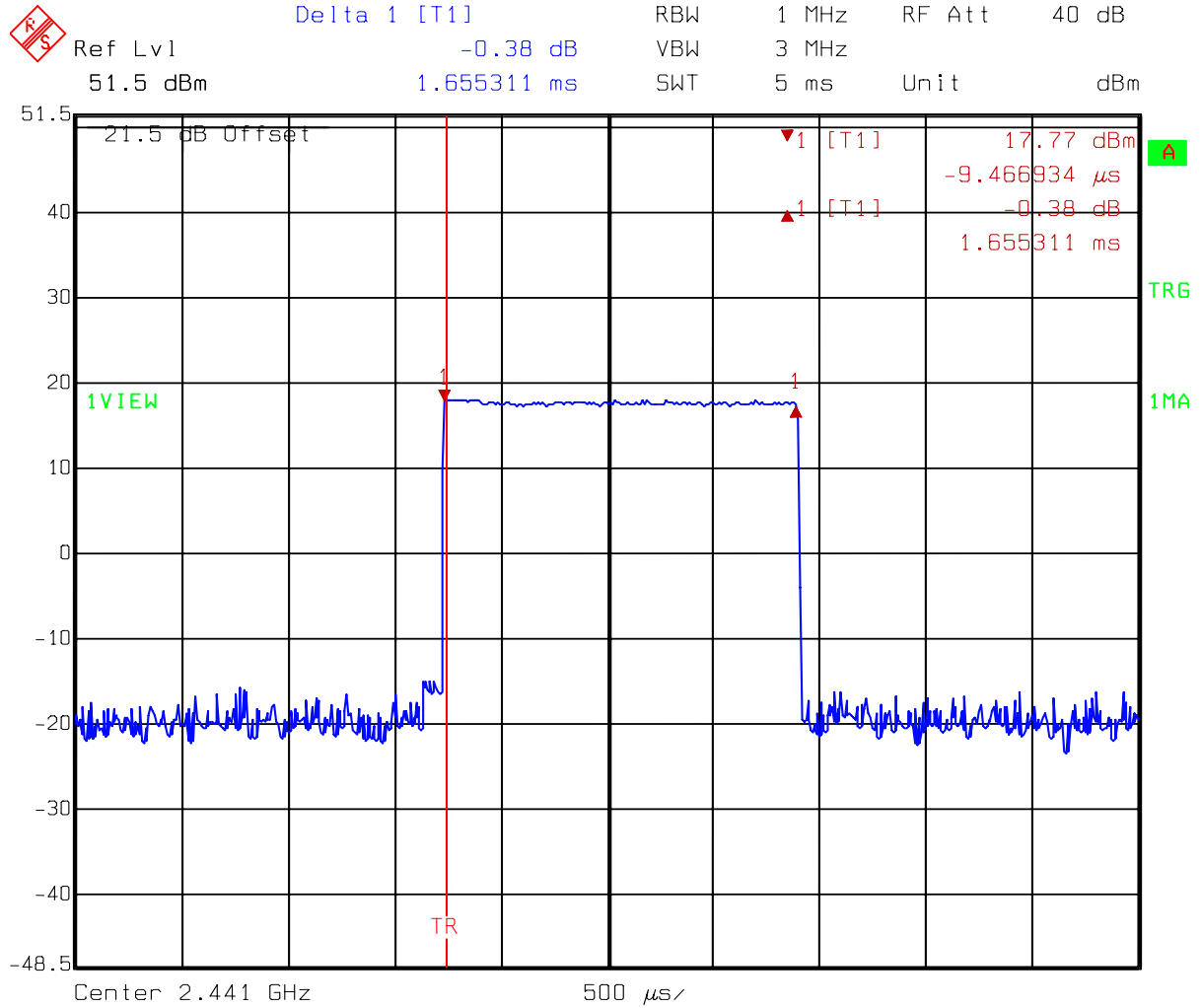

Comment A: Dwell Time at DH3
DQPSK
Date: 11.MAY 2006 17:46:09

Test mode: DQPSK at DH5

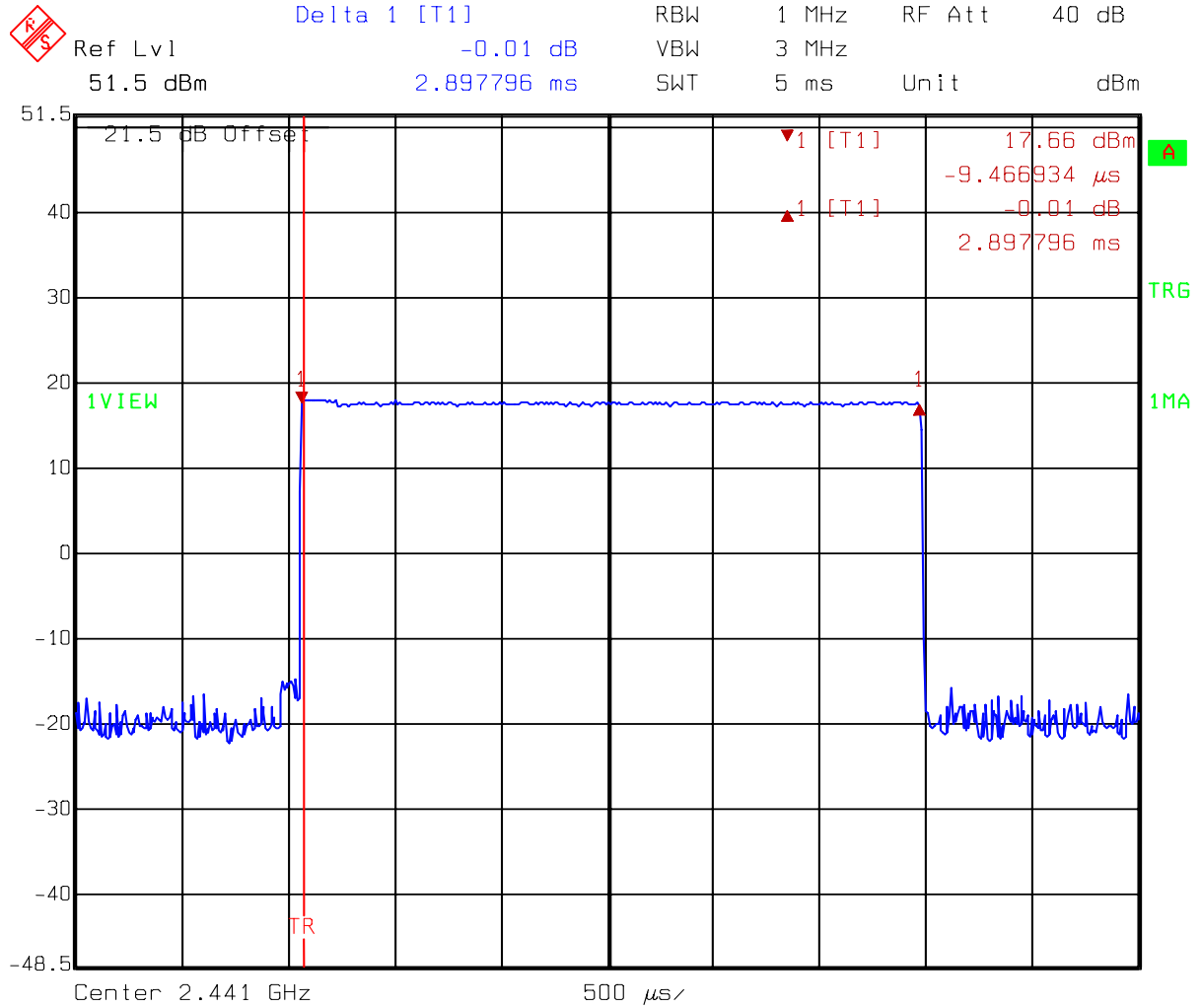

Comment A: Dwell Time at DH5
DQPSK
Date: 11.MAY 2006 17:47:20

Test mode: 8DPSK at DH1

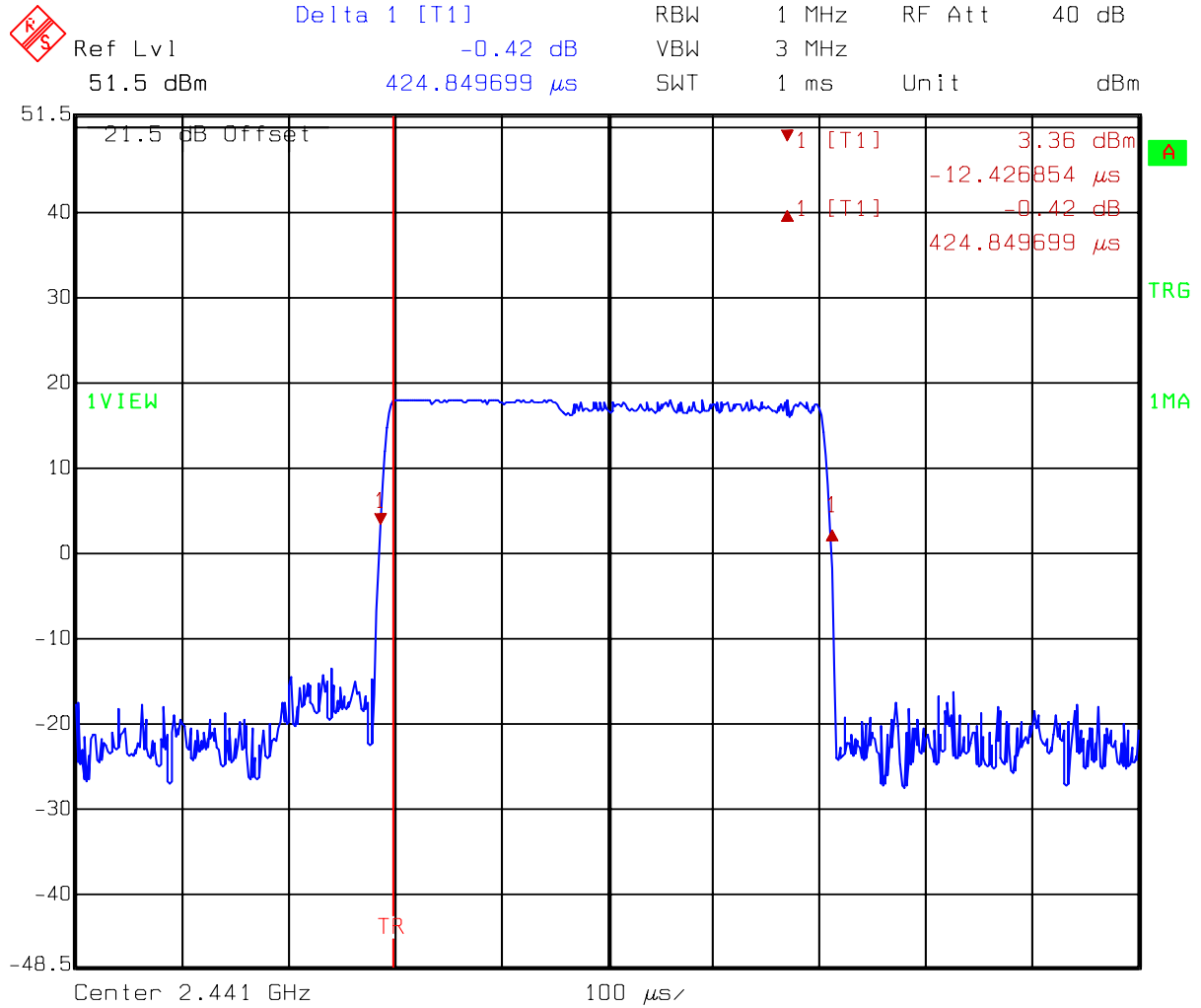

Comment A: Dwell Time at DH1
8DPSK
Date: 11.MAY 2006 17:49:39

Test mode: 8DPSK at DH3

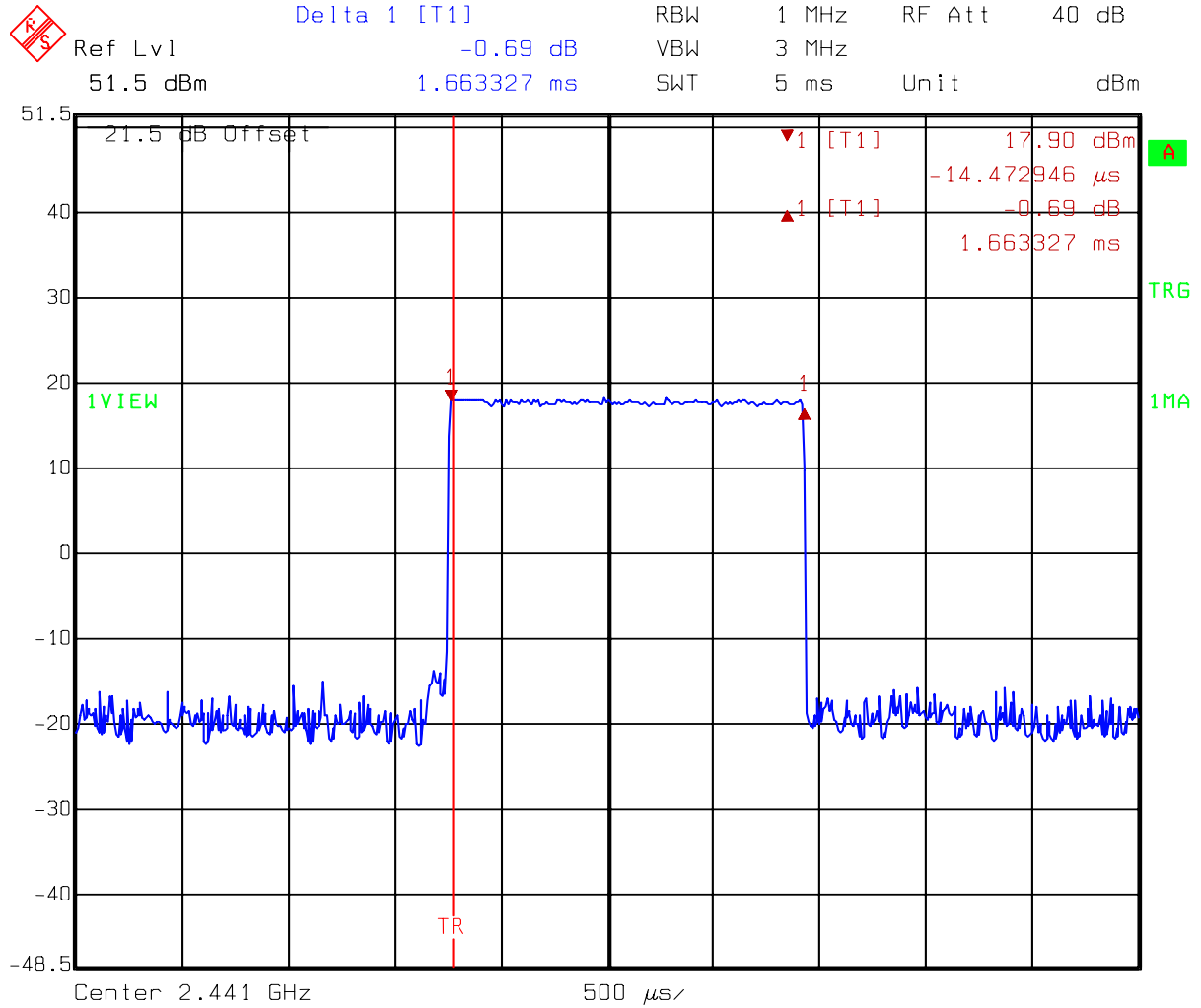

Comment A: Dwell Time at DH3
8DPSK
Date: 11.MAY 2006 17:51:07

Test mode: 8DPSK at DH5

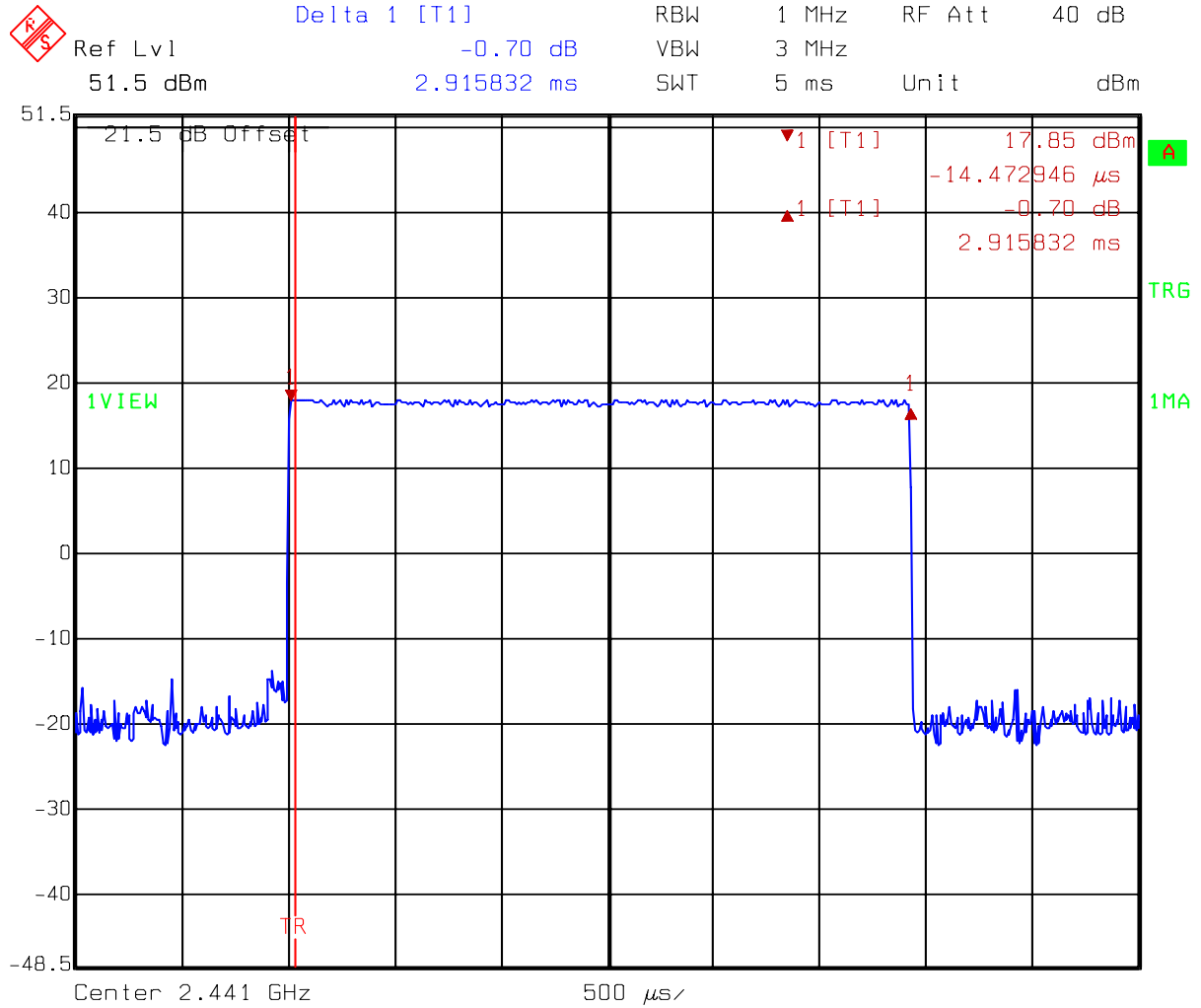

Comment A: Dwell Time at DH5
8DPSK
Date: 11.MAY 2006 17:52:11

7. Maximum Output Power test

7.1 Operating environment

Temperature: 25
 Relative Humidity: 50 %
 Atmospheric Pressure: 1022 hPa

7.2 Test setup & procedure

The power output per FCC §15.247(b) was measured on the EUT using a 50 ohm SMA cable connected to peak power meter via power sensor. Power was read directly and cable loss correction (2 dB) was added to the reading to obtain power at the EUT antenna terminals. The test was performed at 3 channels (lowest, middle and highest channel).

7.3 Measured data of Maximum Output Power test results

Test mode: GFSK

Channel	Freq. (MHz)	C.L. (dB)	Reading (dBm)	Conducted Peak Output Power		Limit (dBm)
				(dBm)	(mW)	
0 (lowest)	2402	2	9.30	11.30	13.49	30
39 (middle)	2441	2	8.90	10.90	12.30	30
78 (highest)	2480	2	5.83	7.83	6.07	30

Test mode: DQPSK

Channel	Freq. (MHz)	C.L. (dB)	Reading (dBm)	Conducted Peak Output Power		Limit (dBm)
				(dBm)	(mW)	
0 (lowest)	2402	2	9.30	11.30	13.49	30
39 (middle)	2441	2	9.20	11.20	13.18	30
78 (highest)	2480	2	-3.12	-1.12	0.77	30

Test mode: 8DPSK

Channel	Freq. (MHz)	C.L. (dB)	Reading (dBm)	Conducted Peak Output Power		Limit (dBm)
				(dBm)	(mW)	
0 (lowest)	2402	2	9.30	11.30	13.49	30
39 (middle)	2441	2	9.20	11.20	12.30	30
78 (highest)	2480	2	-2.93	-0.93	0.81	30

Remark:

Conducted Peak Output Power = Reading + C.L.

8. RF Antenna Conducted Spurious test

8.1 Operating environment

Temperature: 25
Relative Humidity: 56 %

8.2 Test setup & procedure

The measurements were performed from 30MHz to 25GHz RF antenna conducted per FCC 15.247 (c) was measured from the EUT antenna port using a 50ohm spectrum analyzer with the resolution bandwidth set at 100 kHz, and the video bandwidth set at 100 kHz.

Harmonics and spurious noise must be at least 20dB down from the highest emission level within the authorized band as measured with a 100 kHz RBW. The table below is the results from the highest emission for each channel within the authorized band. This table was used to determine the spurious limits for each channel.

8.3 Measured data of the highest RF Antenna Conducted Spurious test result

The test results please see the plot below.

Test mode: GFSK at CH1

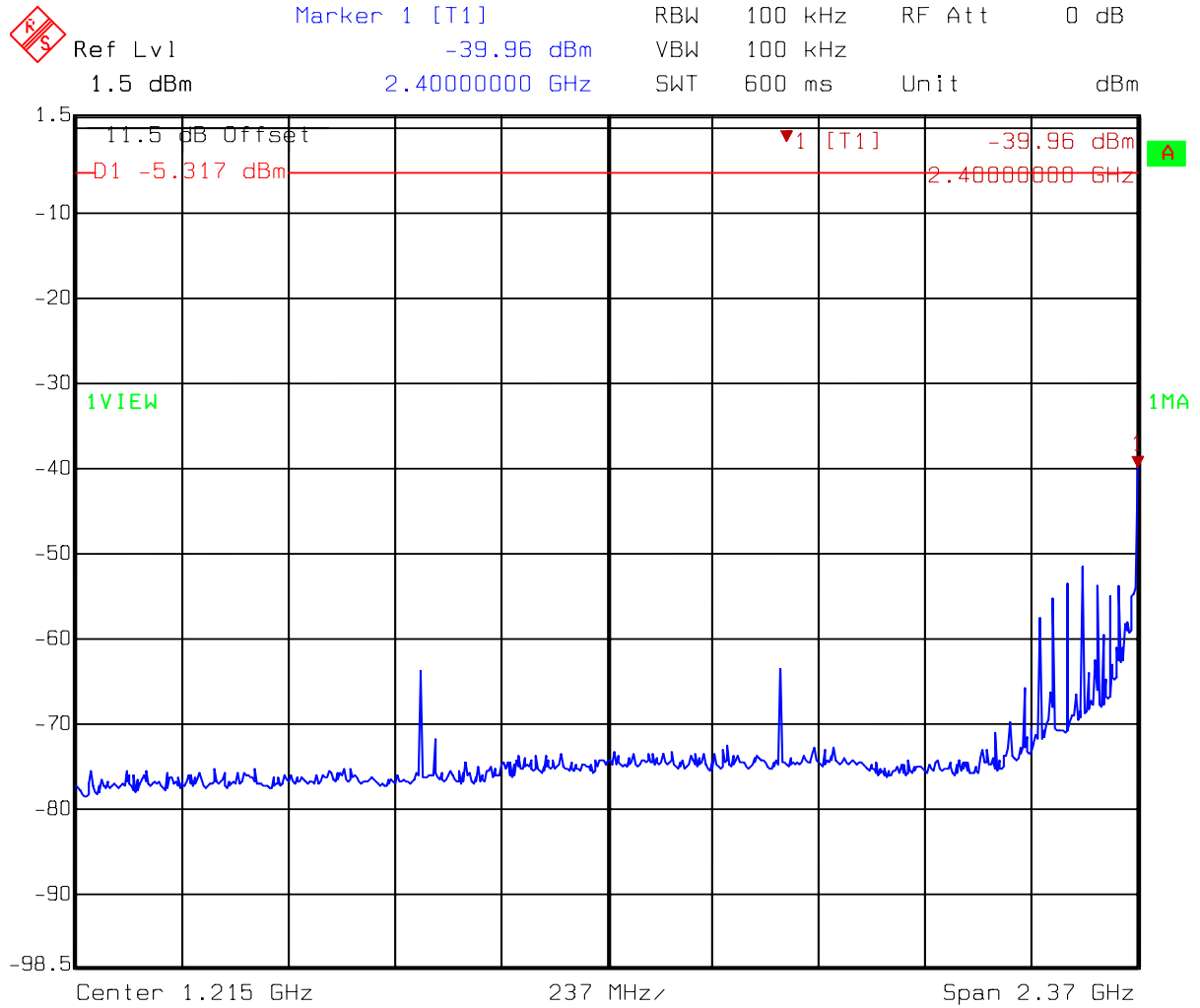

Title: Spurious
 Comment A: CH 1 at Bluetooth mode
 Date: 11.SEP.2006 09:48:56

Test mode: GFSK at CH1

	Marker 1 [T1]	RBW 100 kHz	RF Att 20 dB
Ref Lvl	14.68 dBm	VBW 100 kHz	
21.5 dBm	2.40217535 GHz	SWT 21 ms	Unit dBm

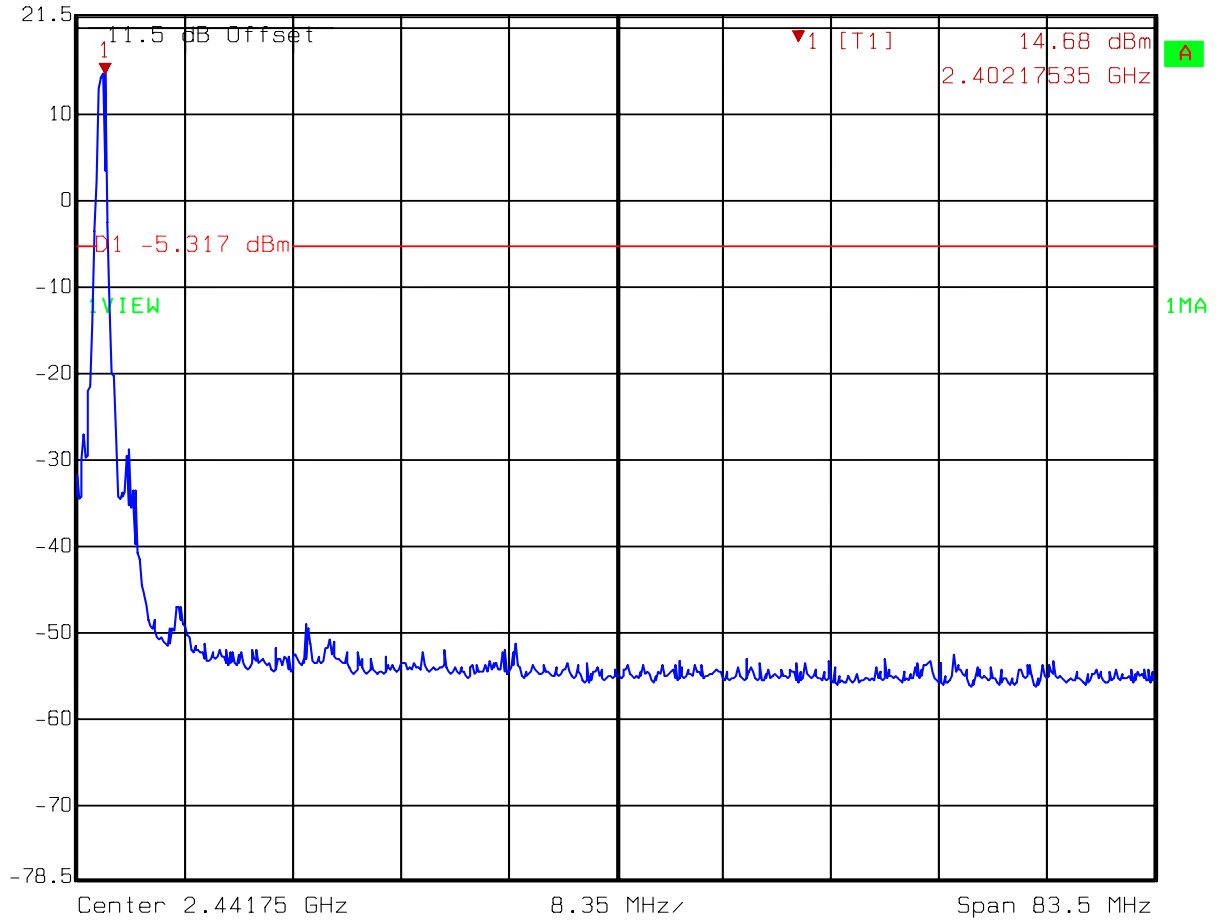

Title: Spurious
 Comment A: CH 1 at Bluetooth mode
 Date: 11.SEP.2006 09:48:34

Test mode: GFSK at CH1

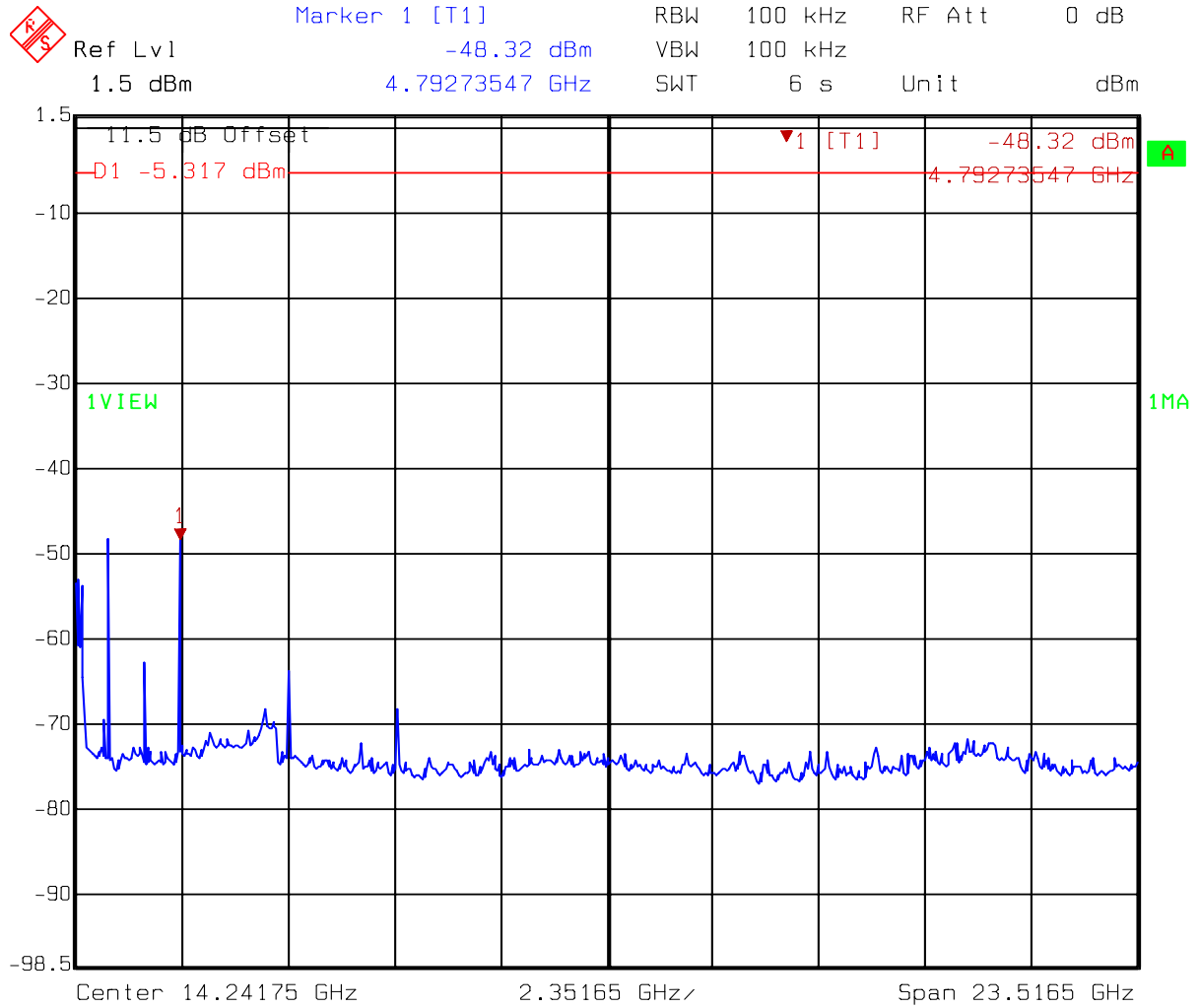

Title: Spurious
 Comment A: CH 1 at Bluetooth mode
 Date: 11.SEP.2006 09:49:23

Test mode: GFSK at CH40

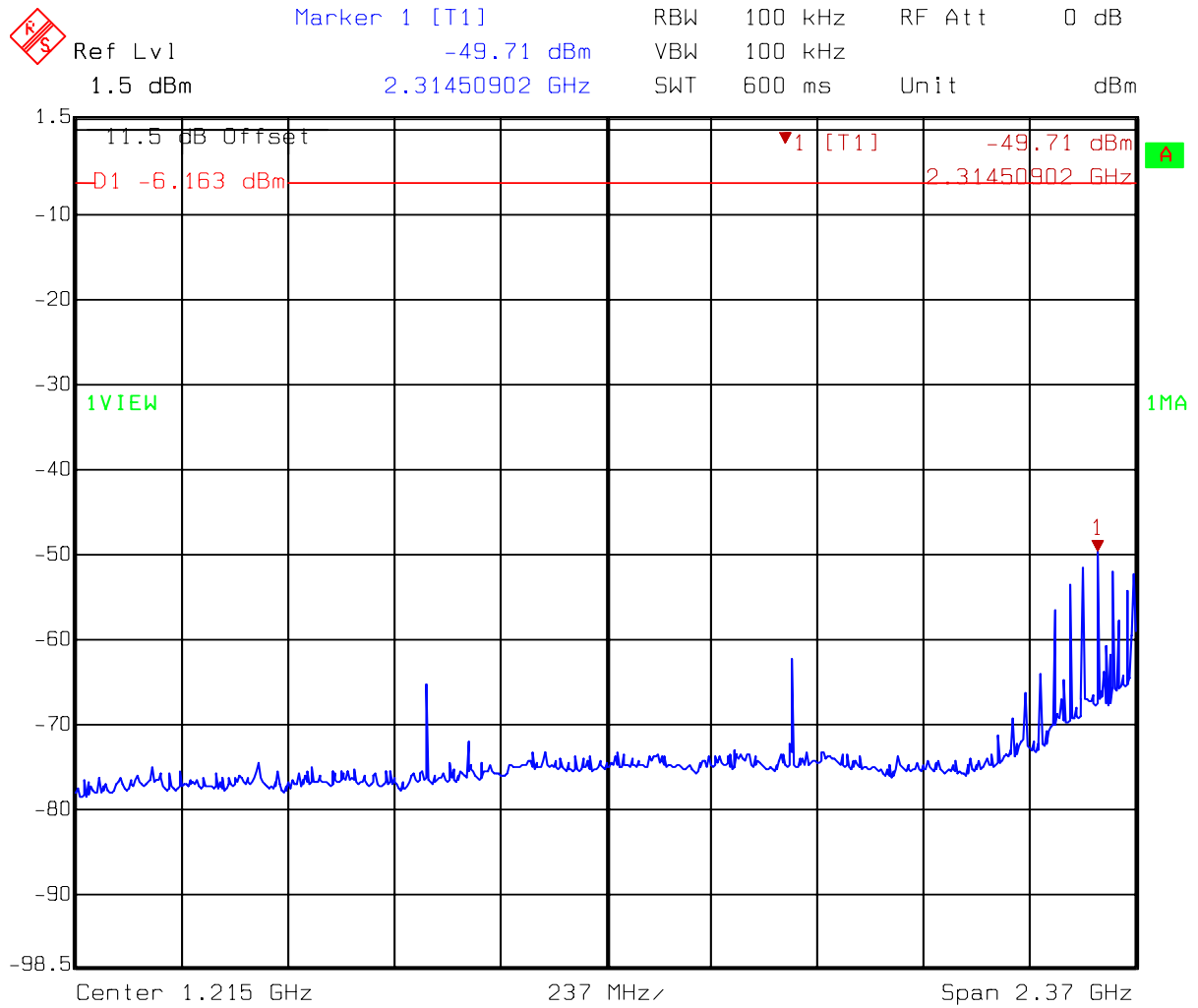

Title: Spurious
 Comment A: CH 40 at Bluetooth mode
 Date: 11.SEP.2006 09:53:34

Test mode: GFSK at CH40

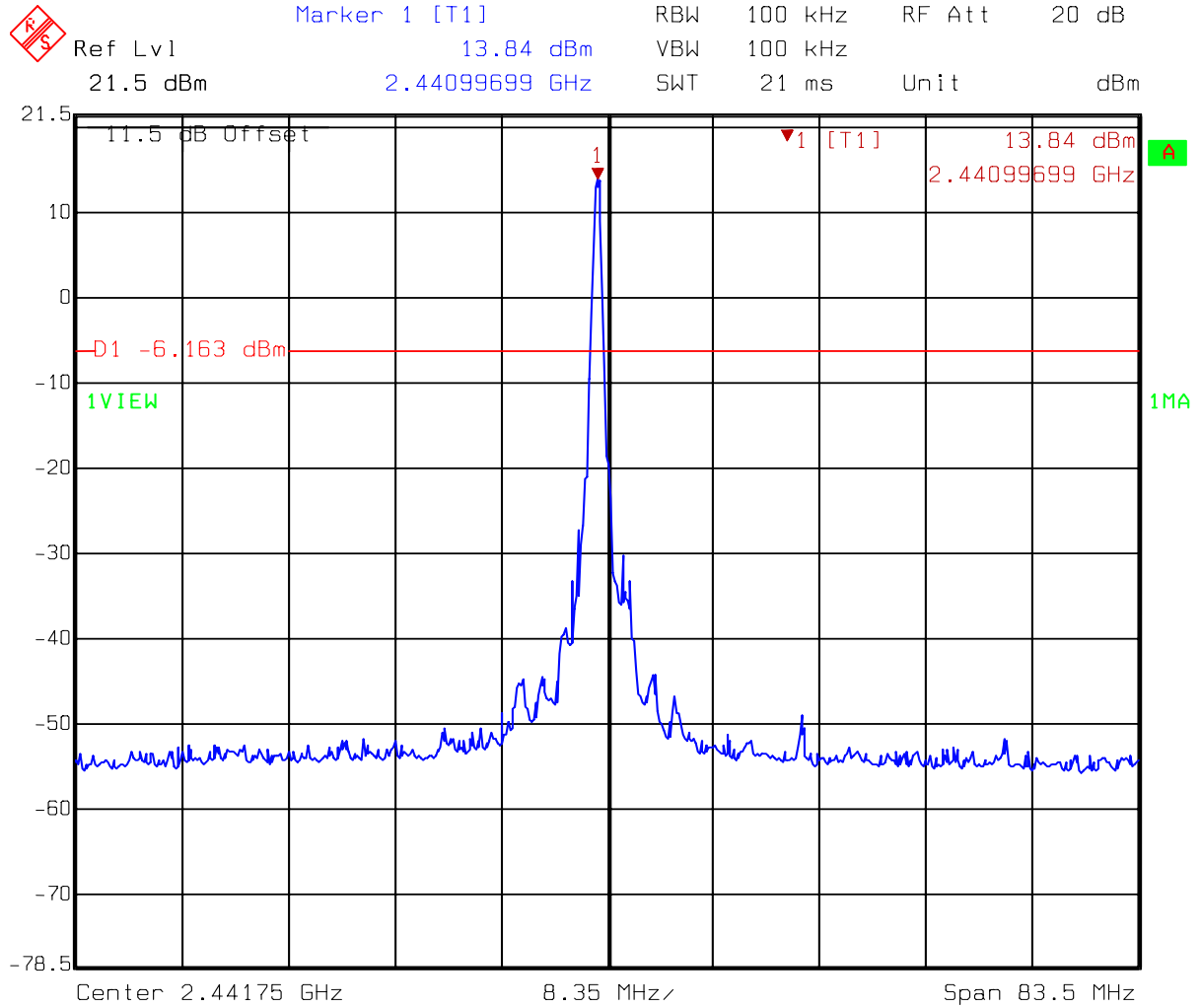

Title: Spurious
 Comment A: CH 40 at Bluetooth mode
 Date: 11.SEP.2006 09:53:13

Test mode: GFSK at CH40

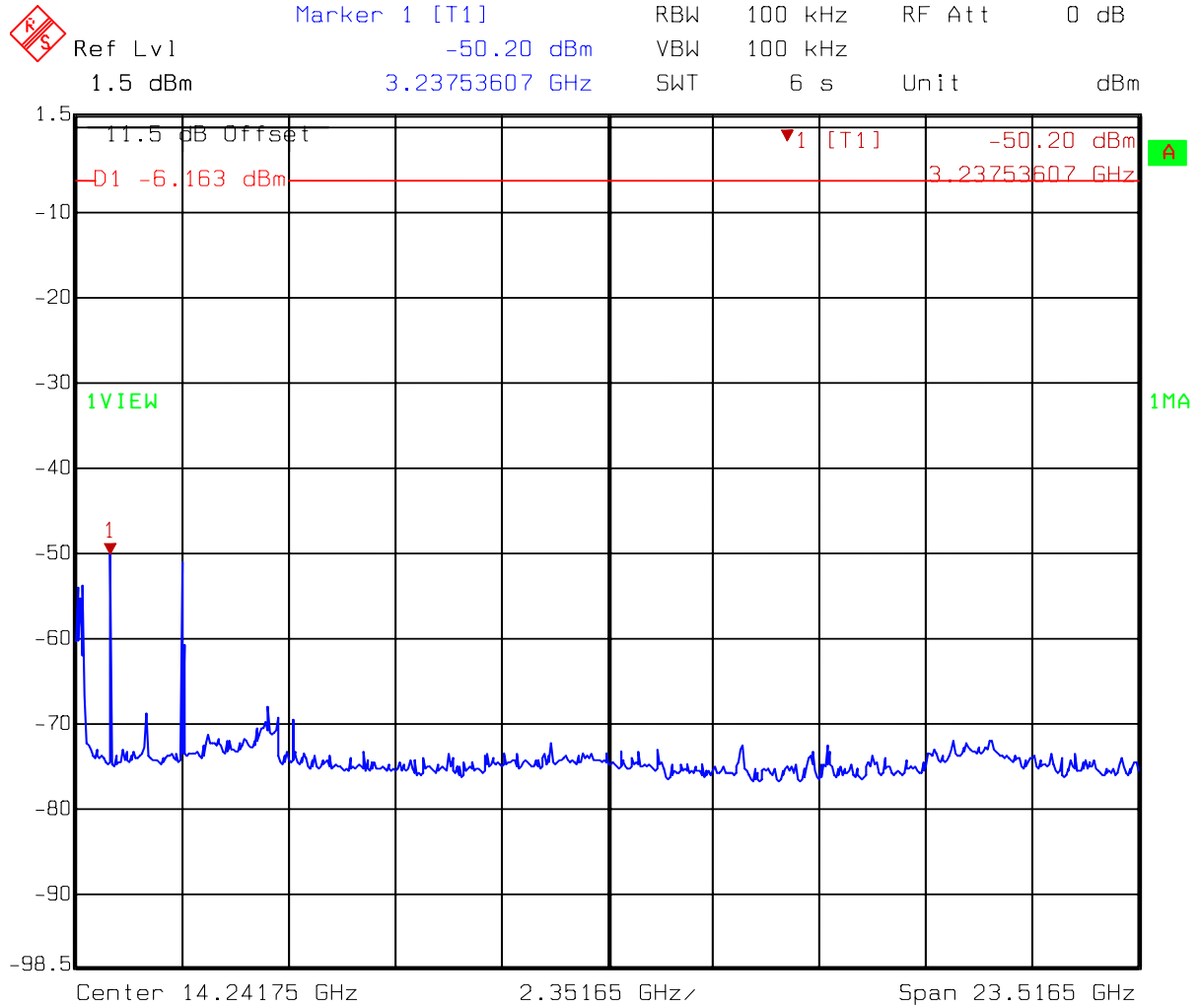

Title: Spurious
 Comment A: CH 40 at Bluetooth mode
 Date: 11.SEP.2006 09:54:02

Test mode: GFSK at CH79

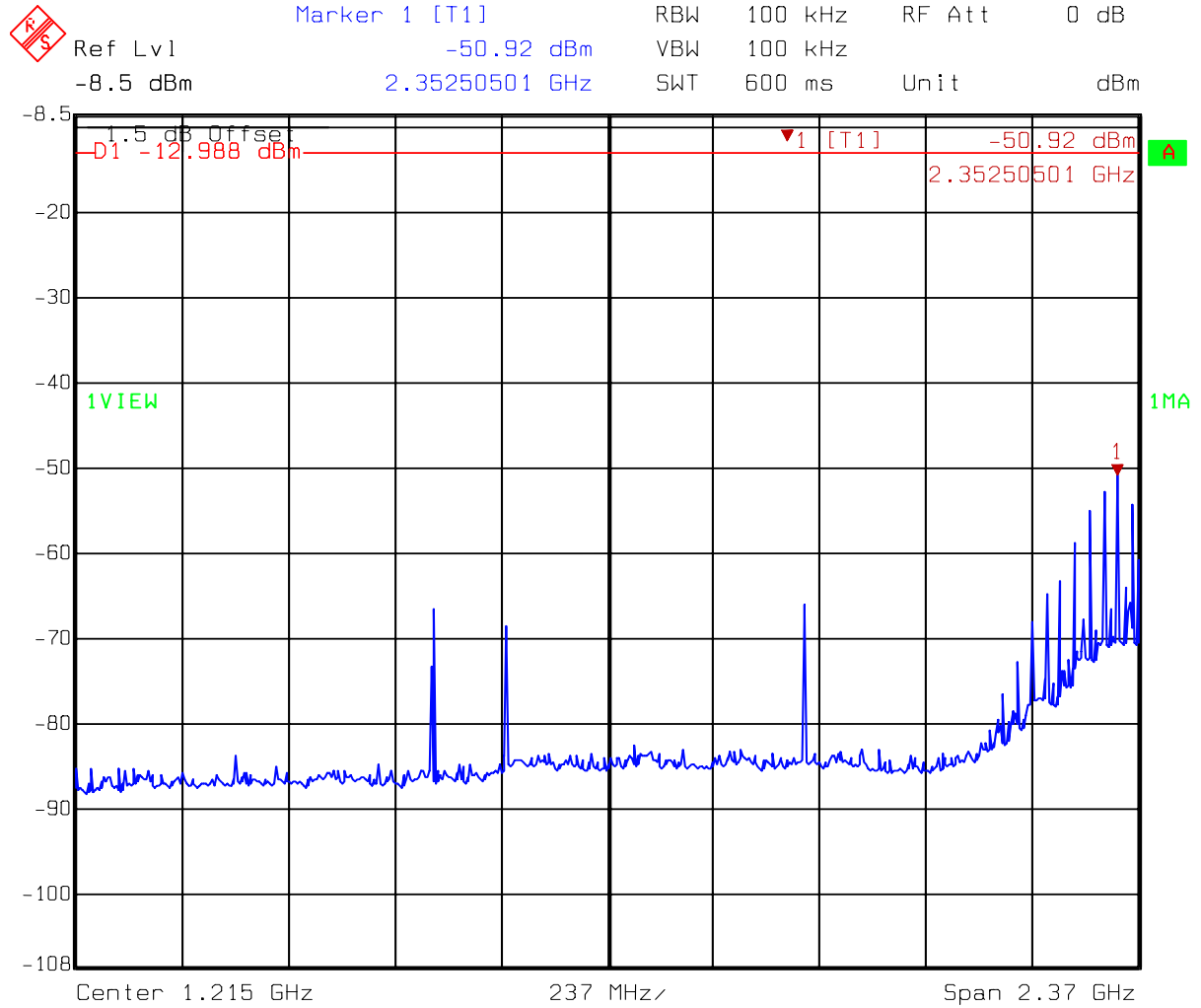

Title: Spurious
 Comment A: CH 79 at Bluetooth mode
 Date: 11.SEP.2006 09:40:04

Test mode: GFSK at CH79

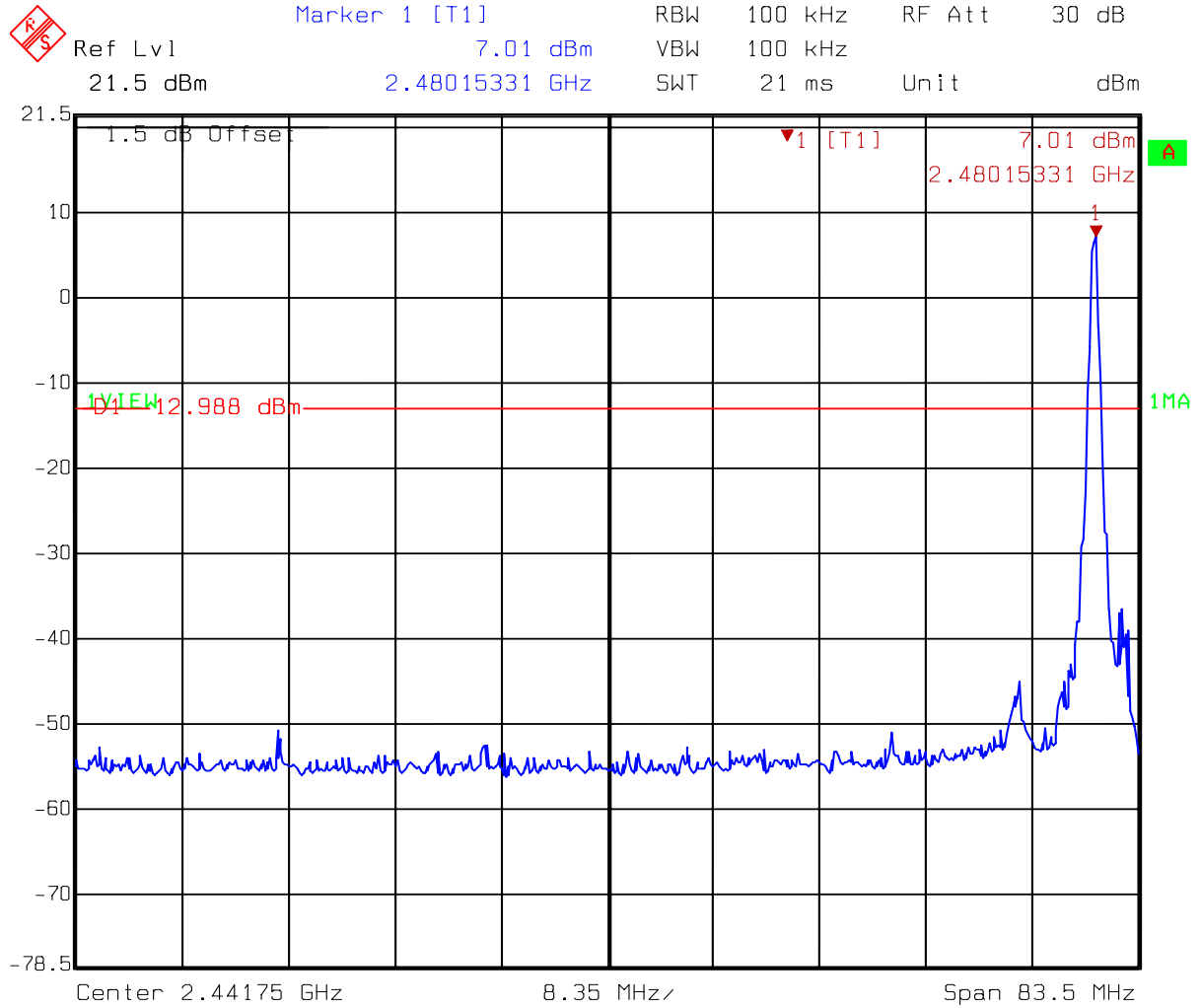

Title: Spurious
 Comment A: CH 79 at Bluetooth mode
 Date: 11.SEP.2006 09:39:43

Test mode: GFSK at CH79

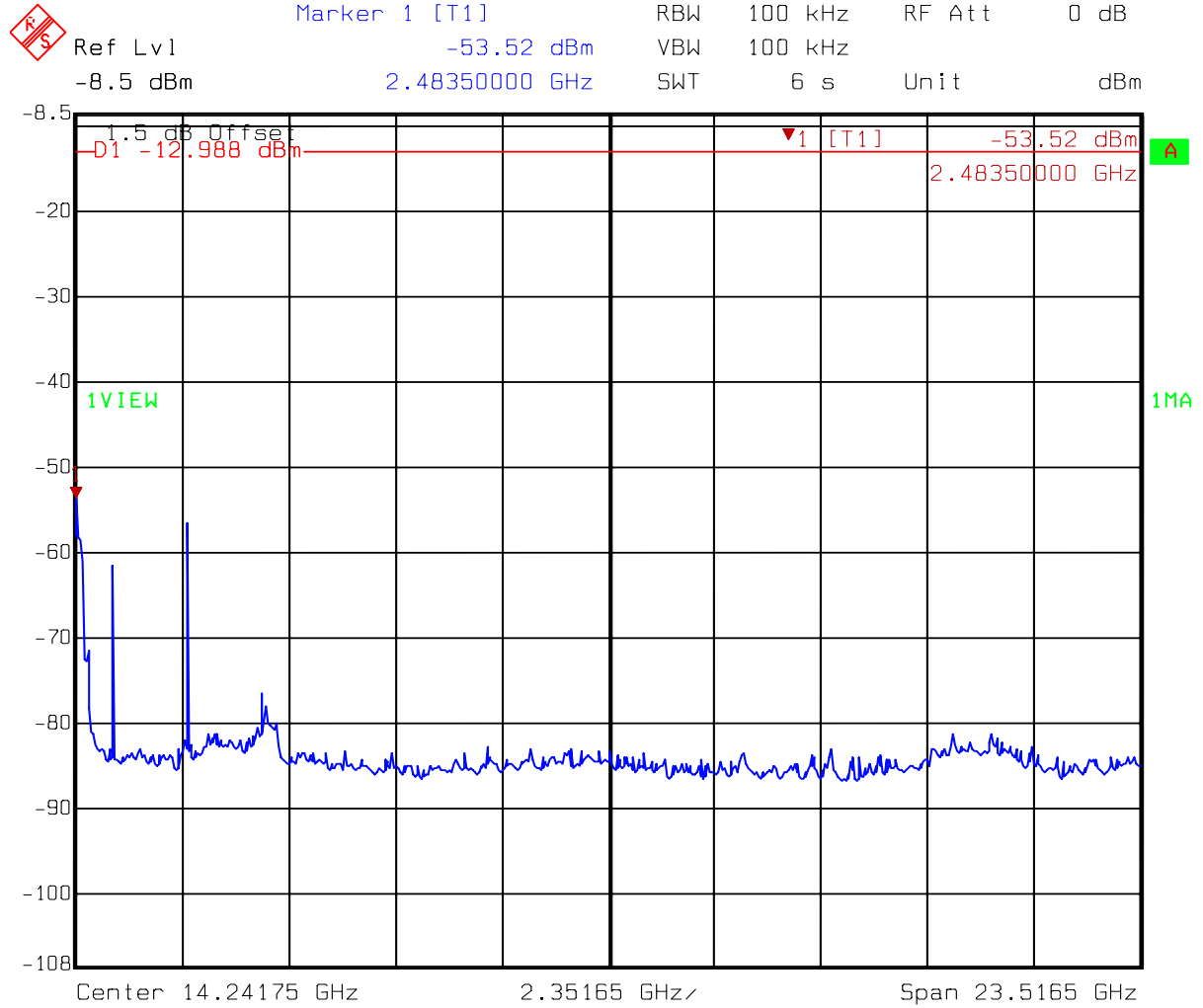

Title: Spurious
 Comment A: CH 79 at Bluetooth mode
 Date: 11.SEP.2006 09:40:32

Test mode: DQPSK at CH 1

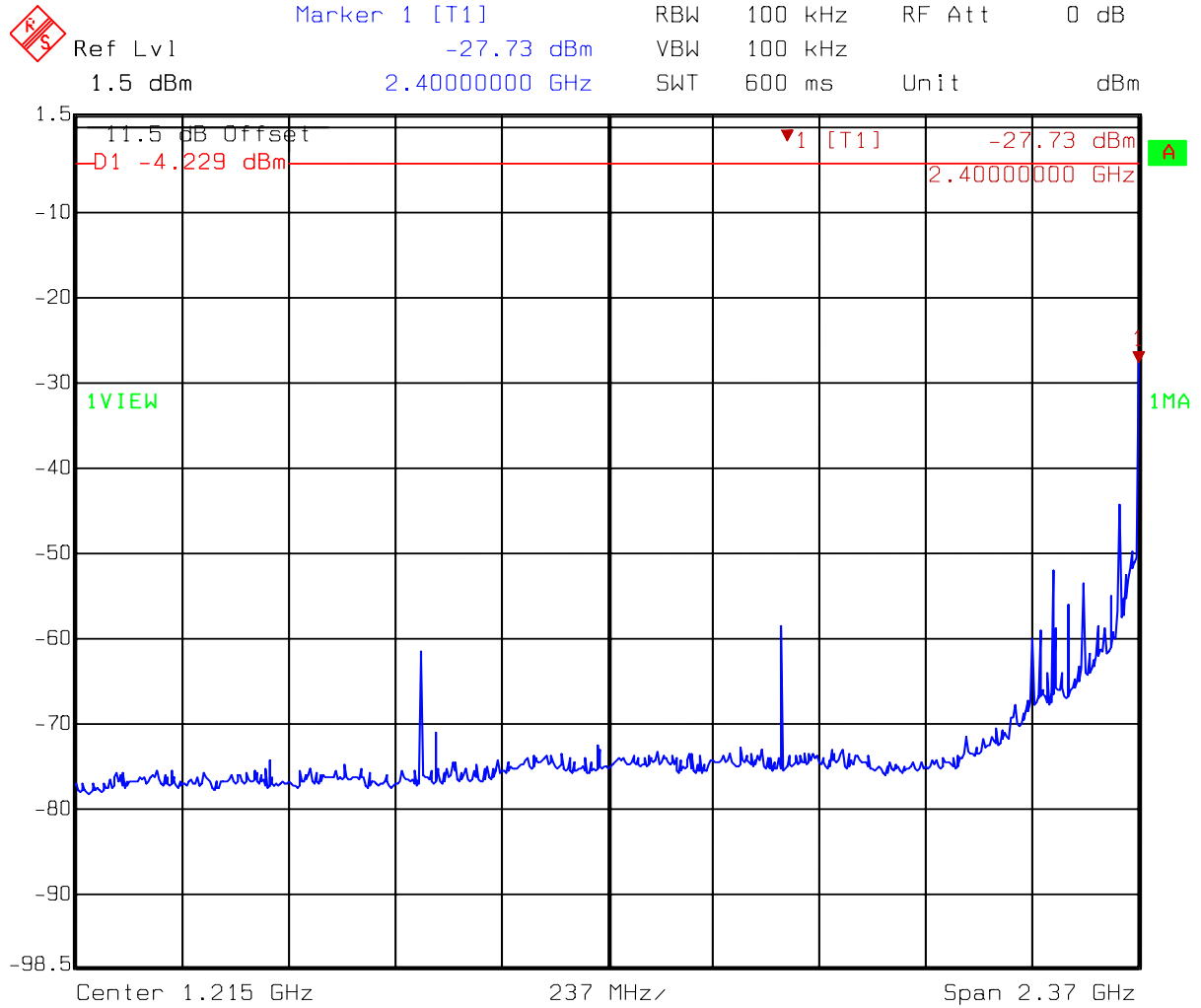

Title: Spurious
 Comment A: CH 1 at Bluetooth mode
 Date: 11.SEP.2006 10:02:13

Test mode: DQPSK at CH 1

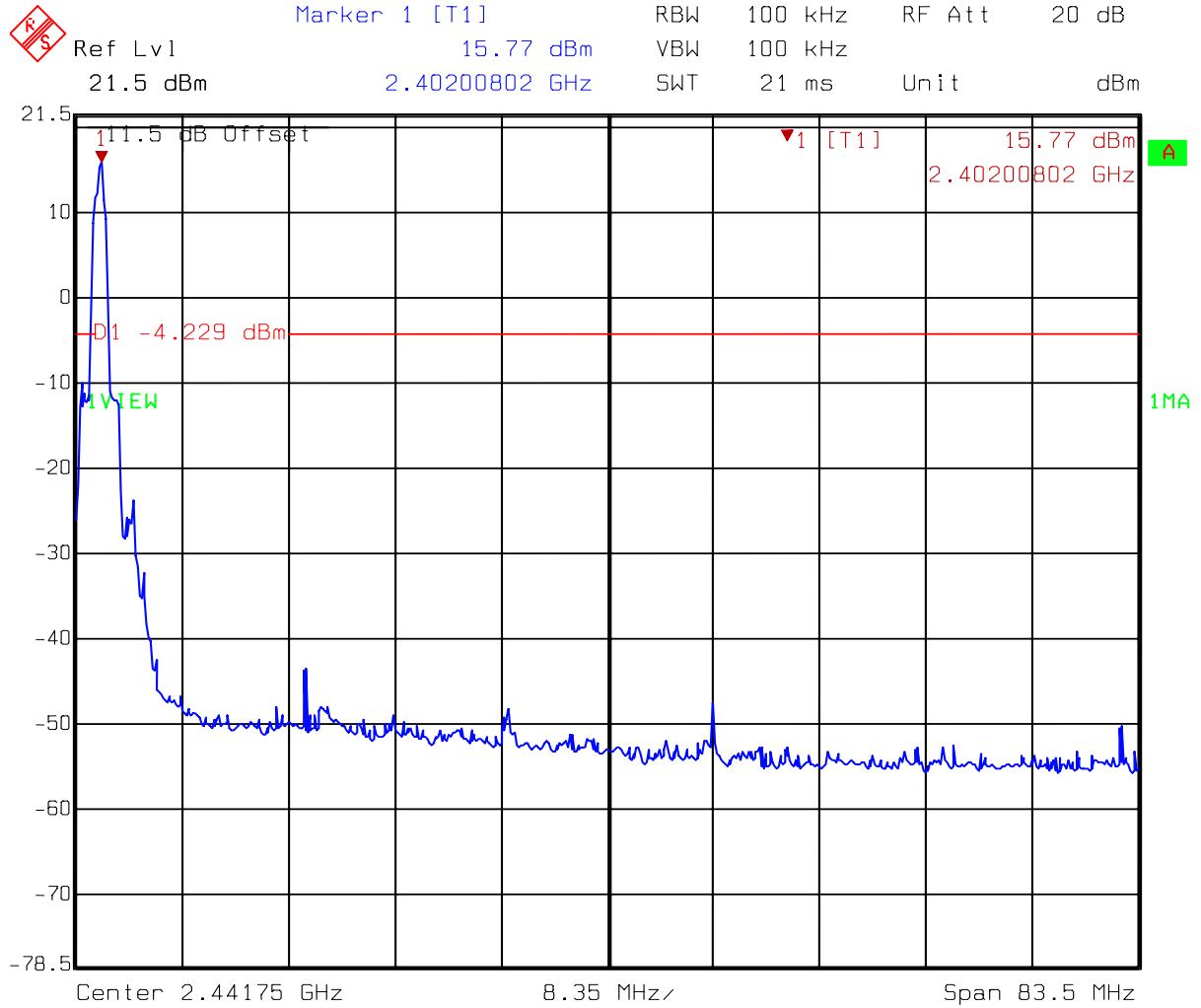

Title: Spurious
 Comment A: CH 1 at Bluetooth mode
 Date: 11.SEP.2006 10:01:51

Test mode: DQPSK at CH 1

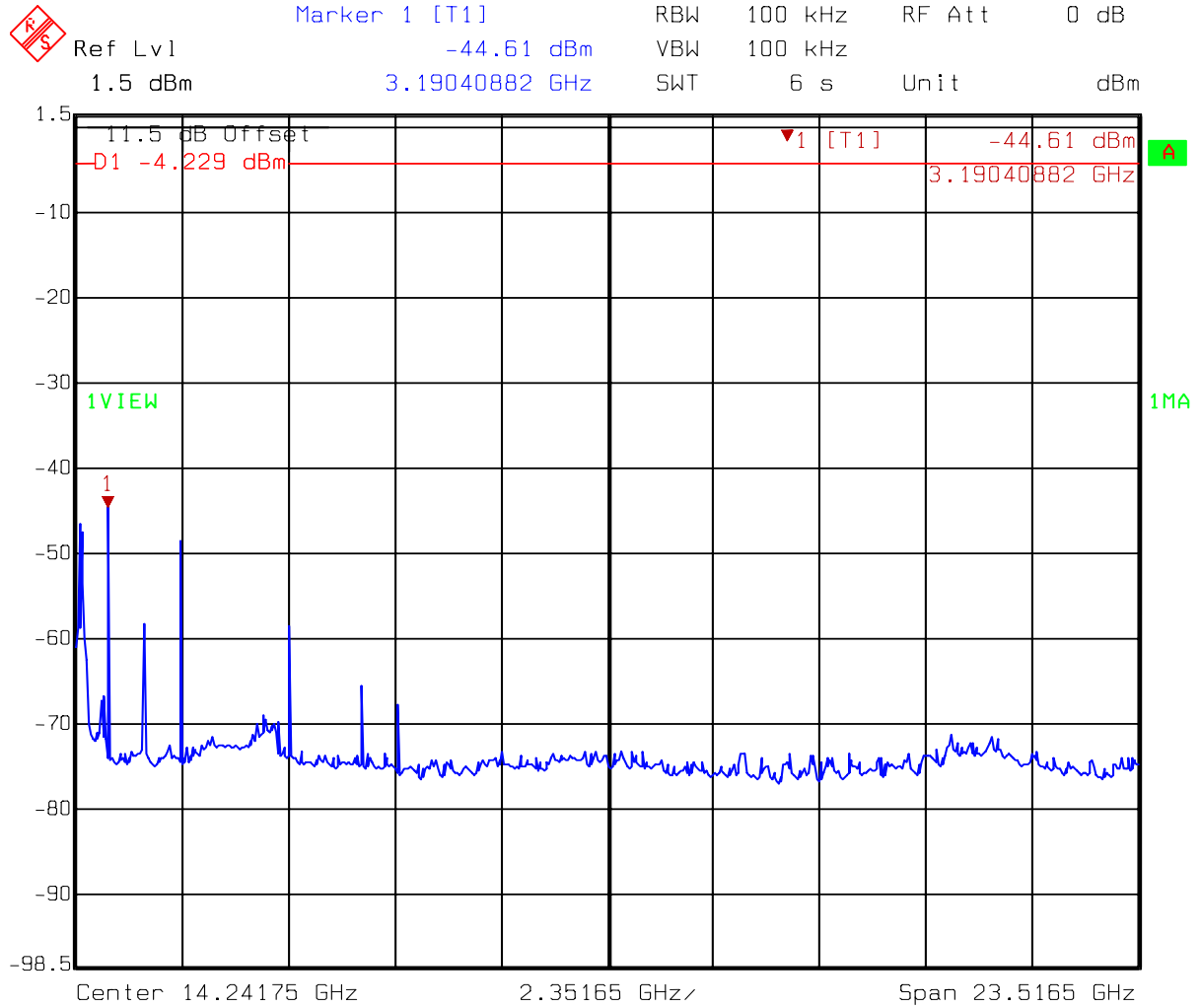

Title: Spurious
 Comment A: CH 1 at Bluetooth mode
 Date: 11.SEP.2006 10:02:40

Test mode: DQPSK at CH 40

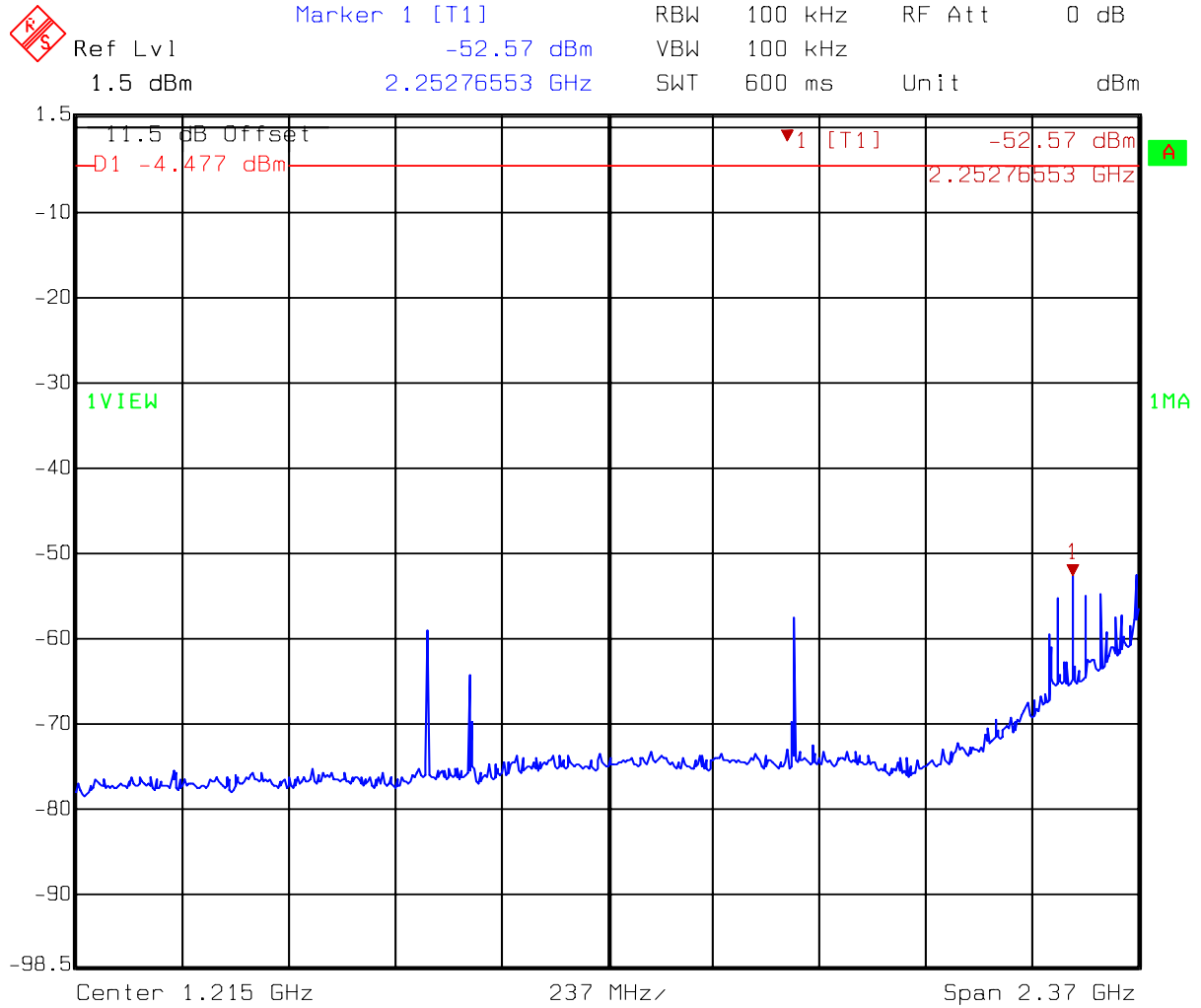

Title: Spurious
 Comment A: CH 40 at Bluetooth mode
 Date: 11.SEP.2006 10:03:56

Test mode: DQPSK at CH 40

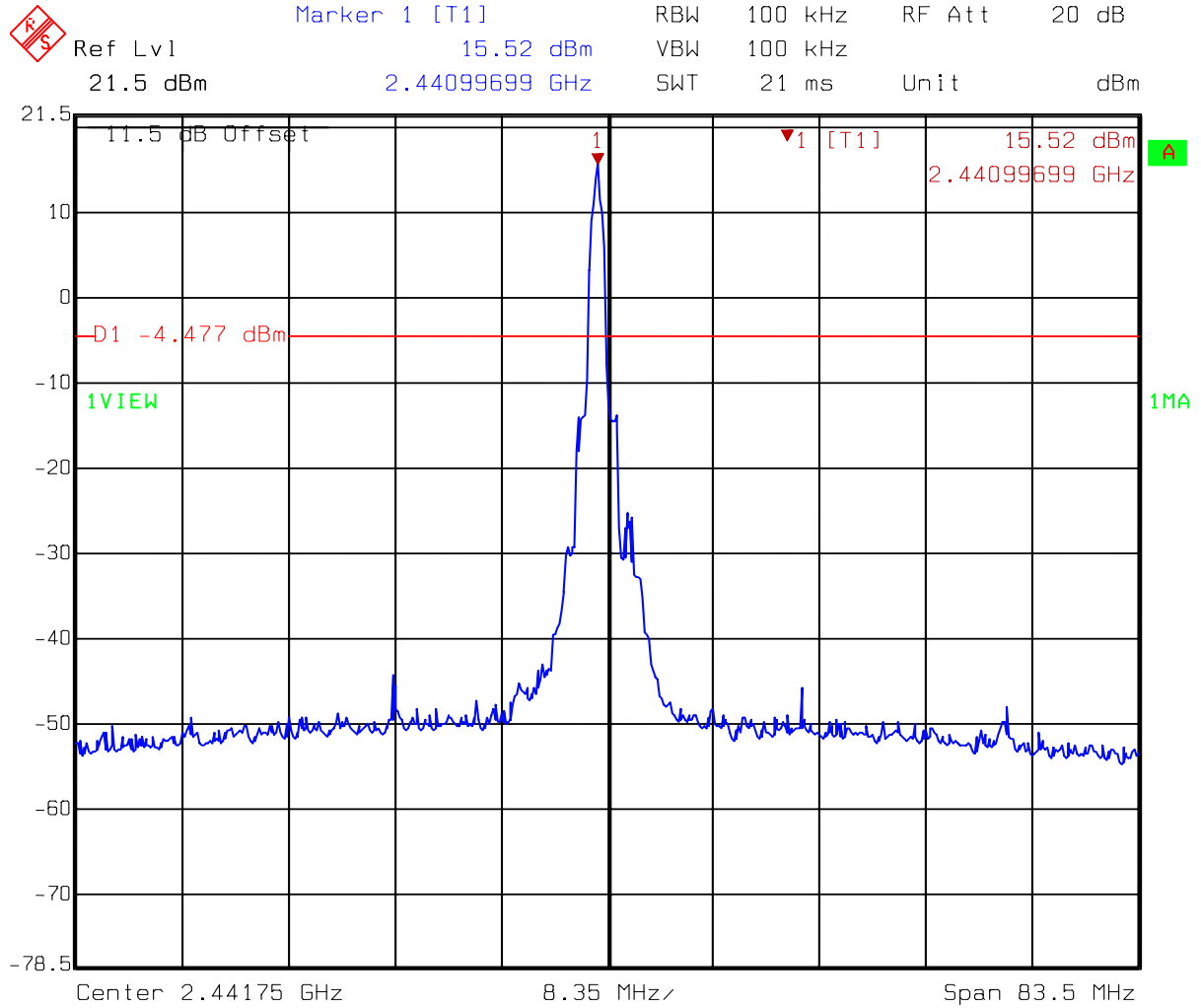

Title: Spurious
 Comment A: CH 40 at Bluetooth mode
 Date: 11.SEP.2006 10:03:35

Test mode: DQPSK at CH 40

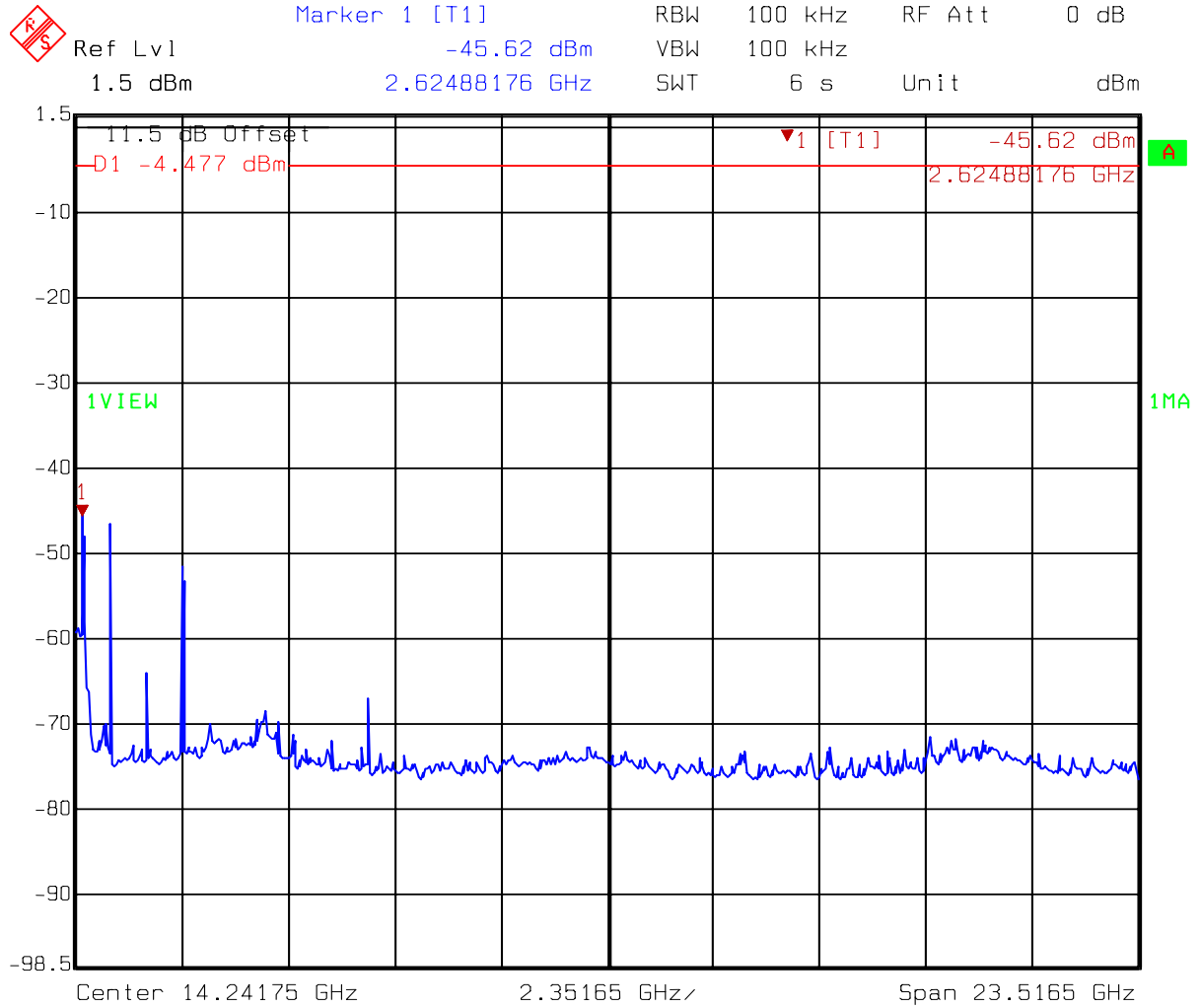

Title: Spurious
 Comment A: CH 40 at Bluetooth mode
 Date: 11.SEP.2006 10:04:24

Test mode: DQPSK at CH 79

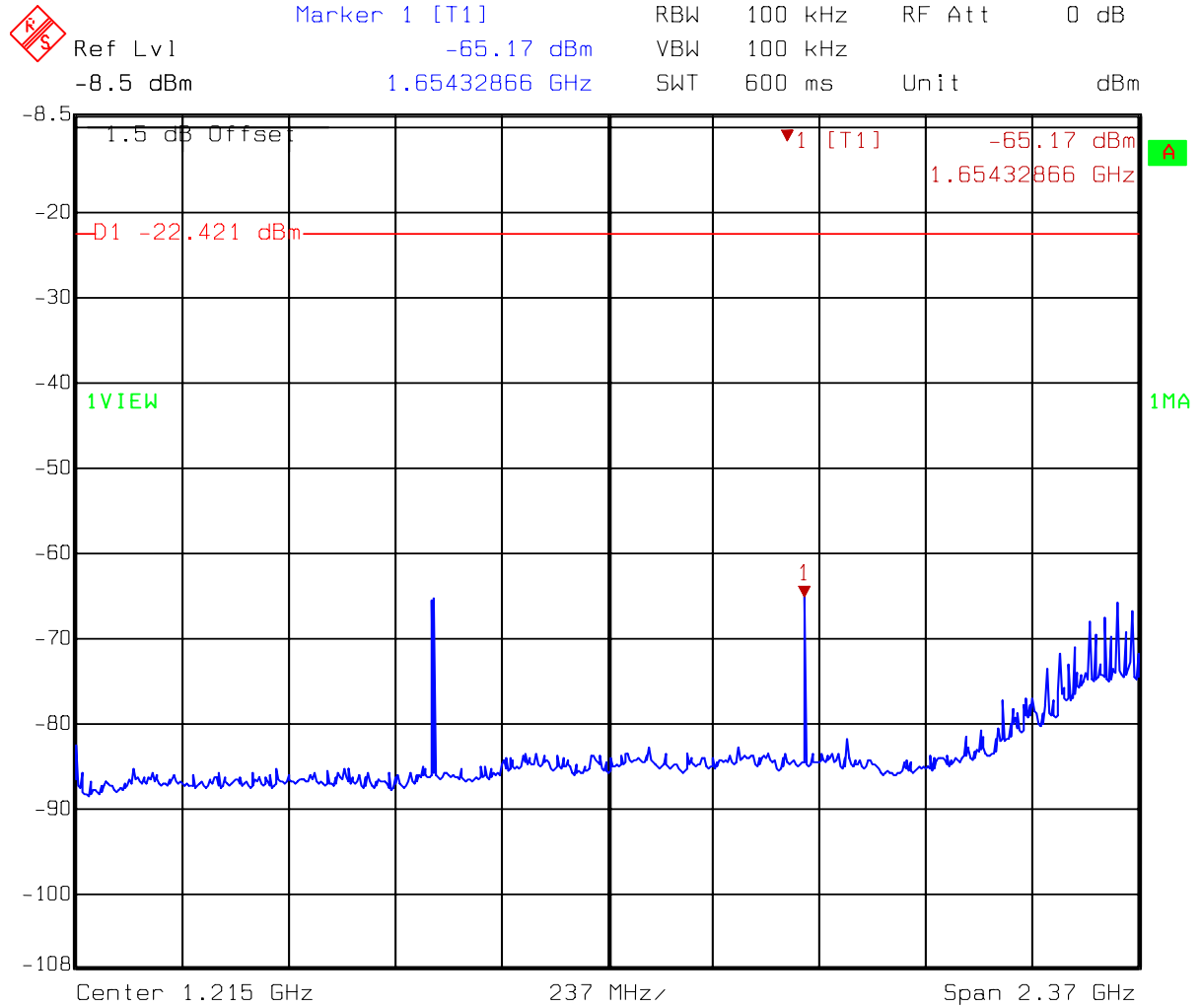

Title: Spurious
 Comment A: CH 79 at Bluetooth mode
 Date: 11.SEP.2006 10:08:42

Test mode: DQPSK at CH 79

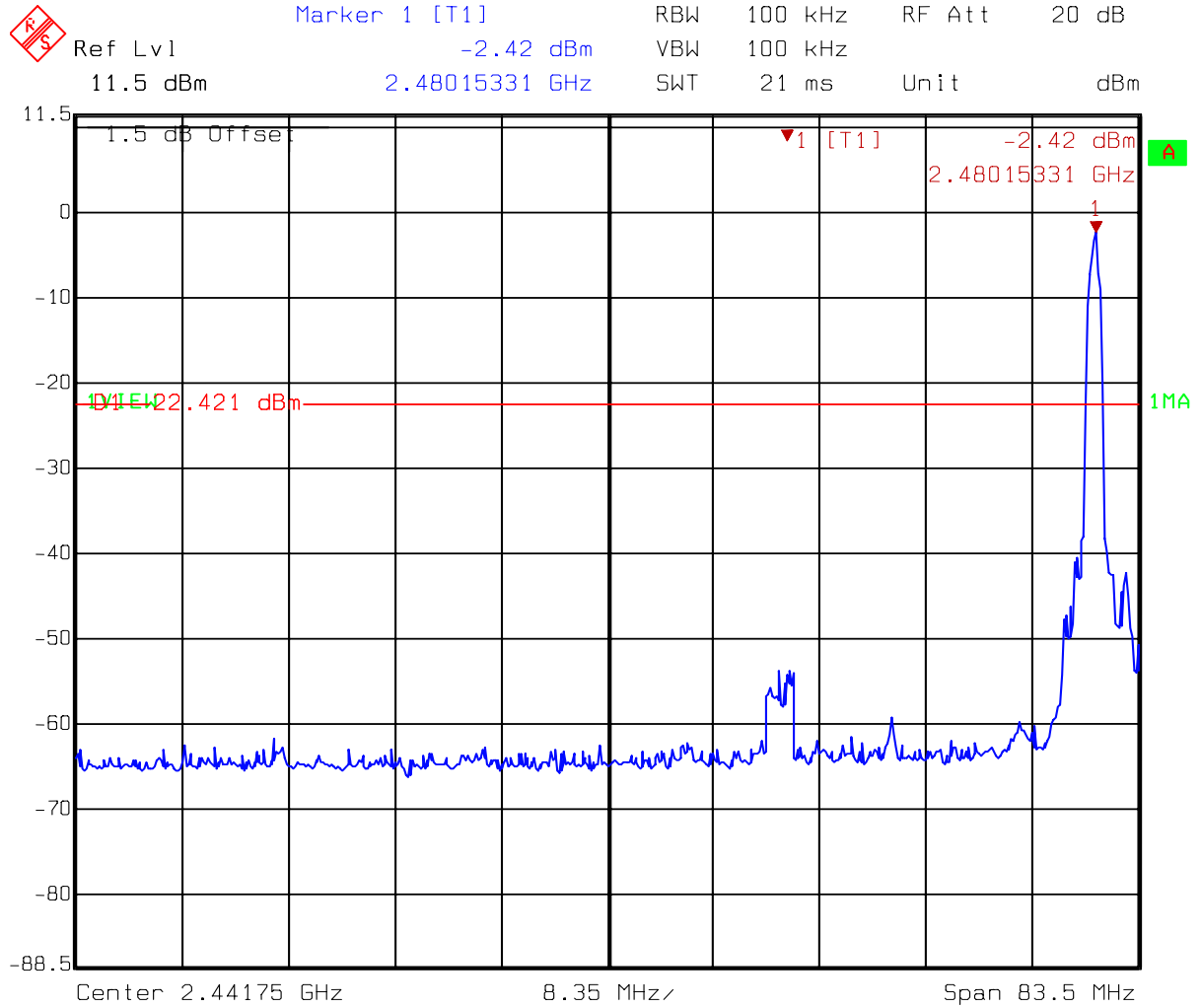

Title: Spurious
 Comment A: CH 79 at Bluetooth mode
 Date: 11.SEP.2006 10:08:21

Test mode: DQPSK at CH 79

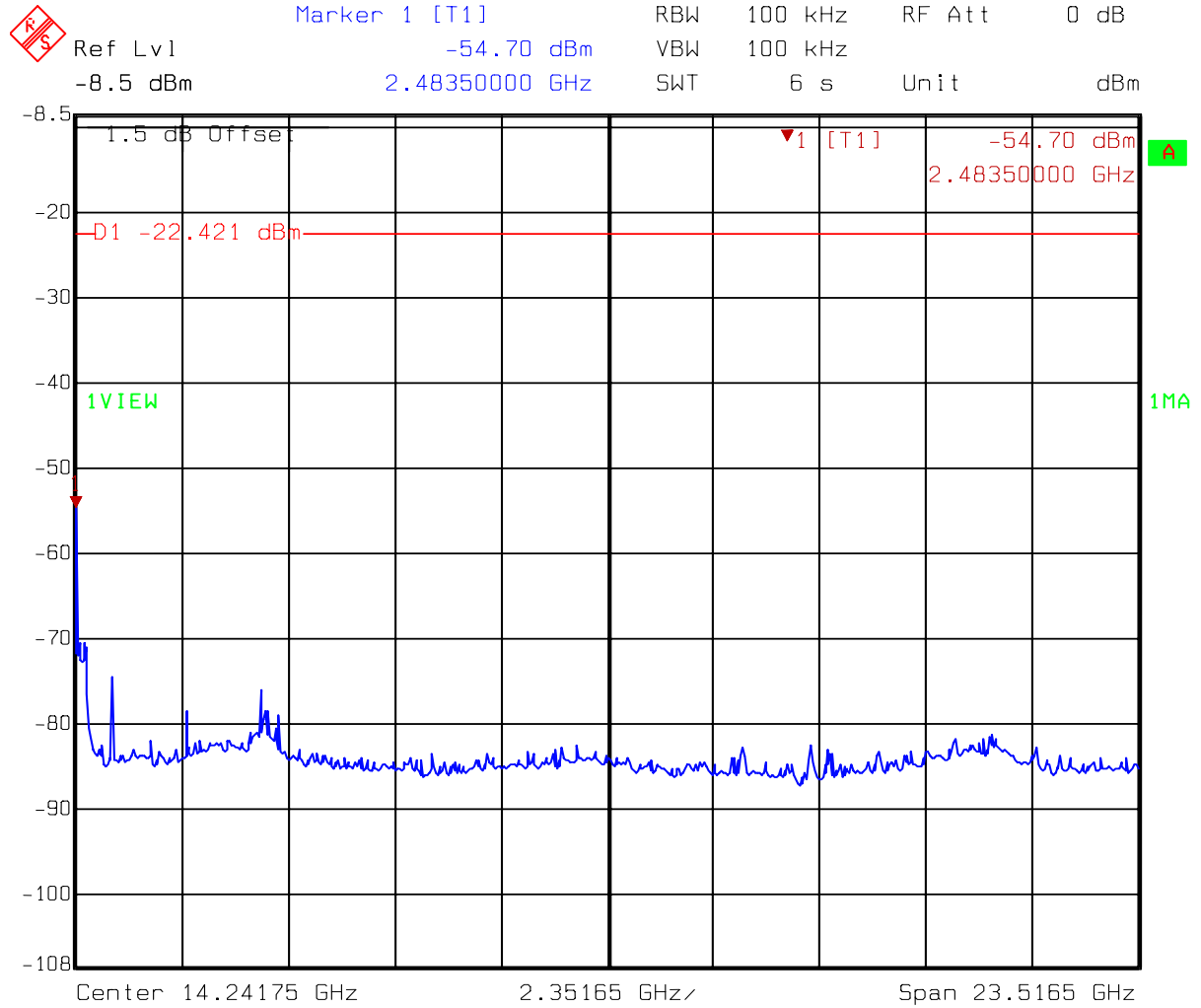

Title: Spurious
 Comment A: CH 79 at Bluetooth mode
 Date: 11.SEP.2006 10:09:10

Test mode: 8DPSK at CH 1

	Ref Lvl	Marker 1 [T1]	RBW	100 kHz	RF Att	0 dB
	1.5 dBm	-25.83 dBm	VBW	100 kHz		
		2.40000000 GHz	SWT	600 ms	Unit	dBm

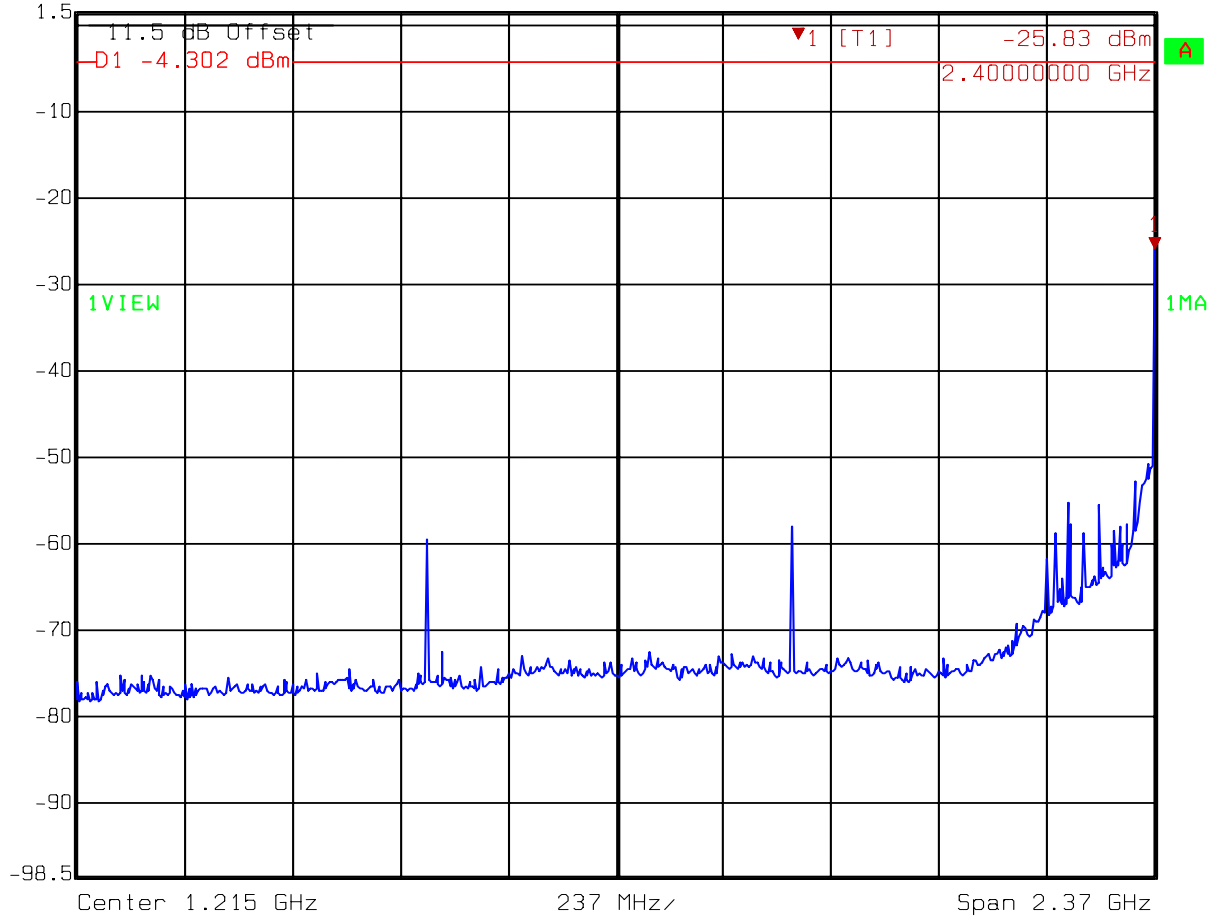

Title: Spurious
 Comment A: CH 1 at Bluetooth mode
 Date: 11.SEP.2006 10:21:19

Test mode: 8DPSK at CH 1

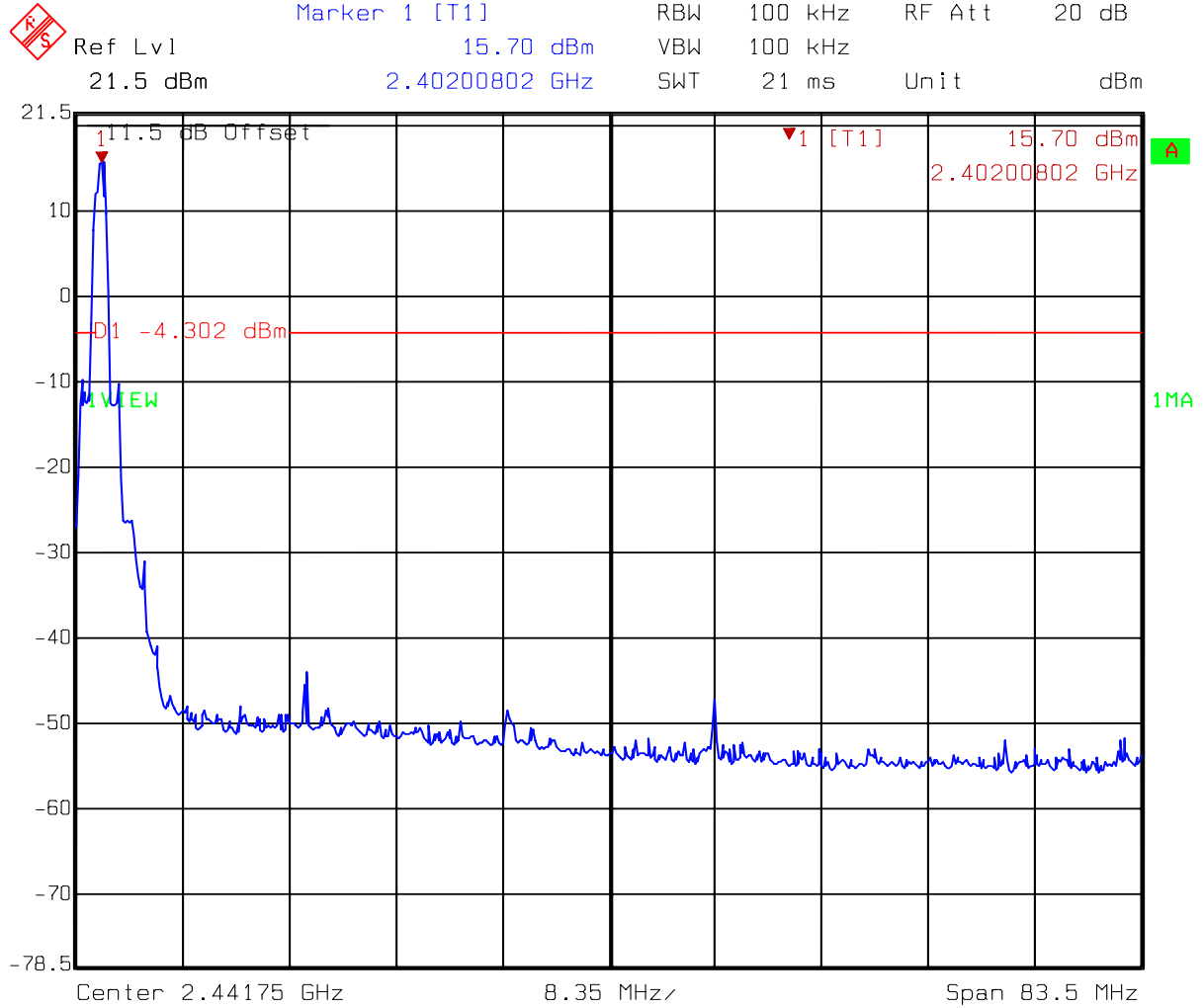

Title: Spurious
 Comment A: CH 1 at Bluetooth mode
 Date: 11.SEP.2006 10:20:58

Test mode: 8DPSK at CH 1

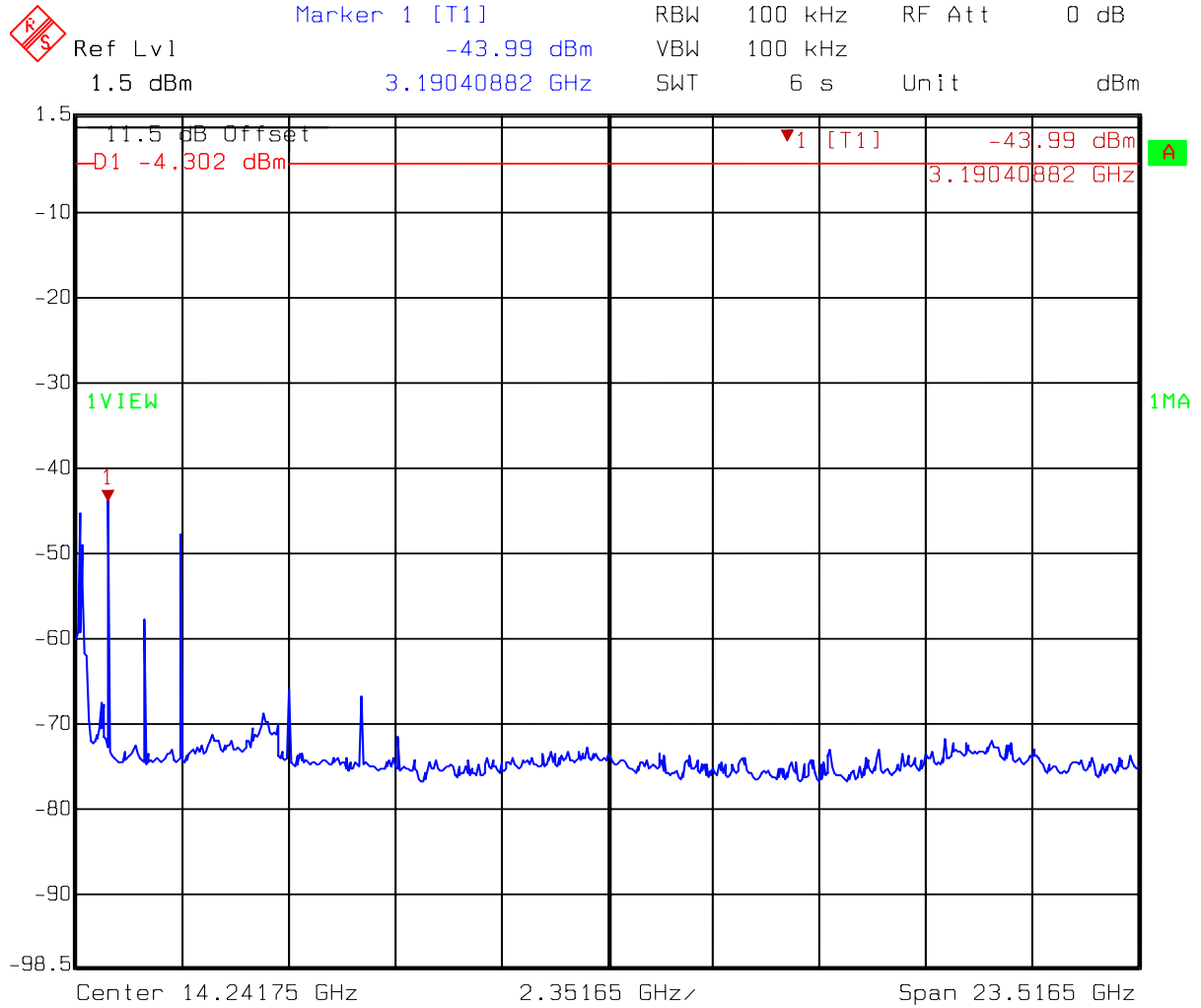

Title: Spurious
 Comment A: CH 1 at Bluetooth mode
 Date: 11.SEP.2006 10:21:47

Test mode: 8DPSK at CH 40

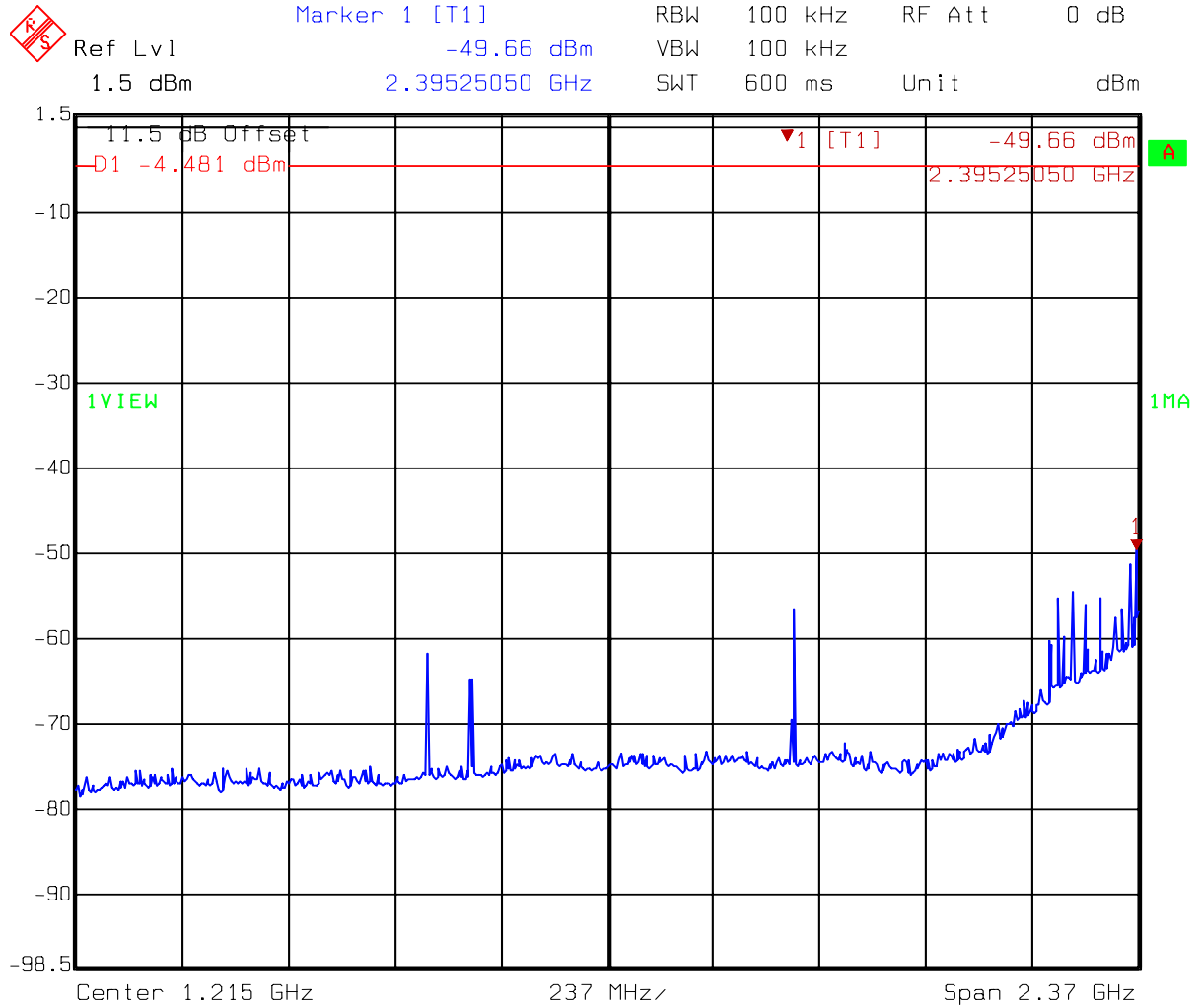

Title: Spurious
 Comment A: CH 40 at Bluetooth mode
 Date: 11.SEP.2006 10:17:10

Test mode: 8DPSK at CH 40

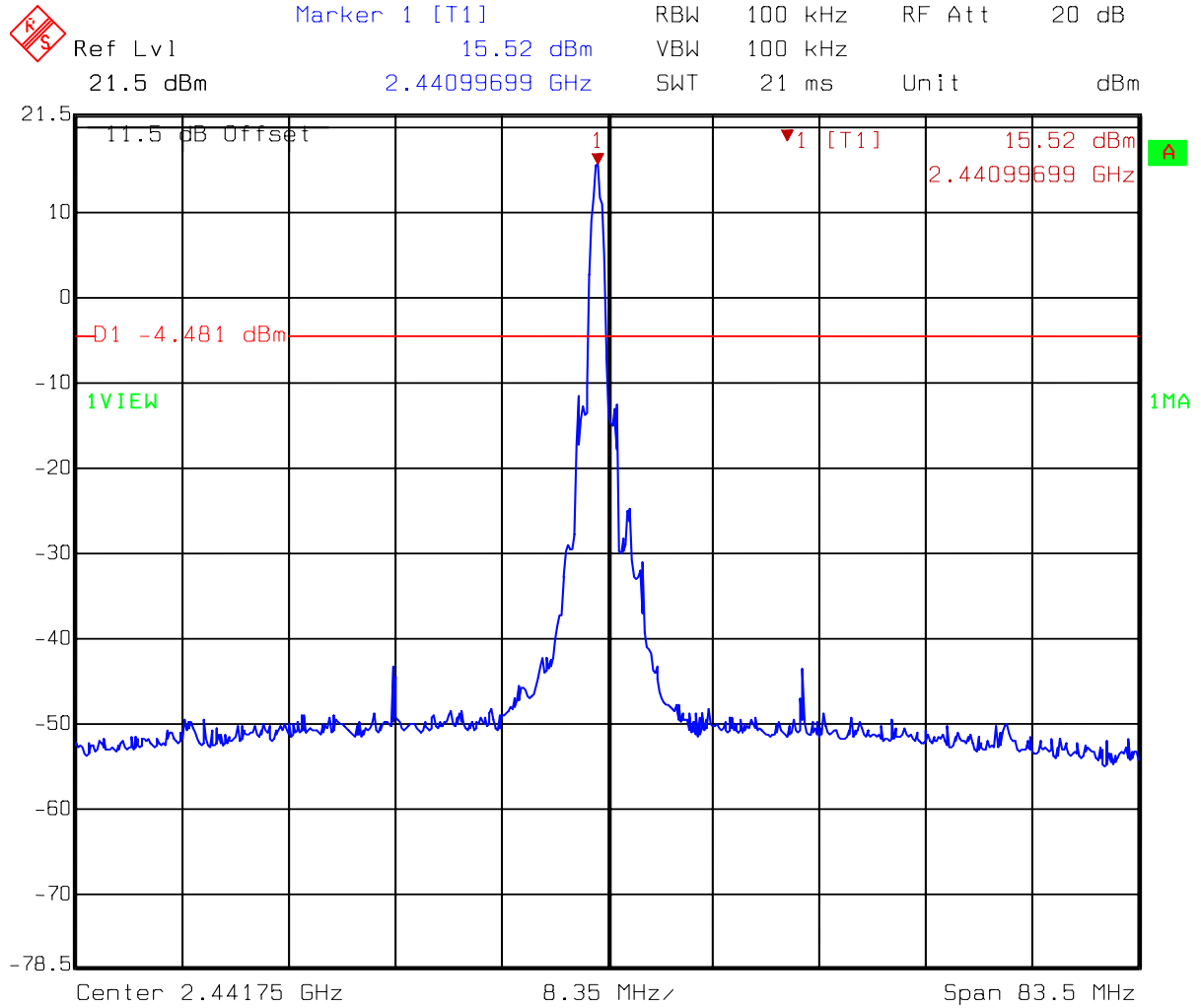

Title: Spurious
 Comment A: CH 40 at Bluetooth mode
 Date: 11.SEP.2006 10:16:48

Test mode: 8DPSK at CH 40

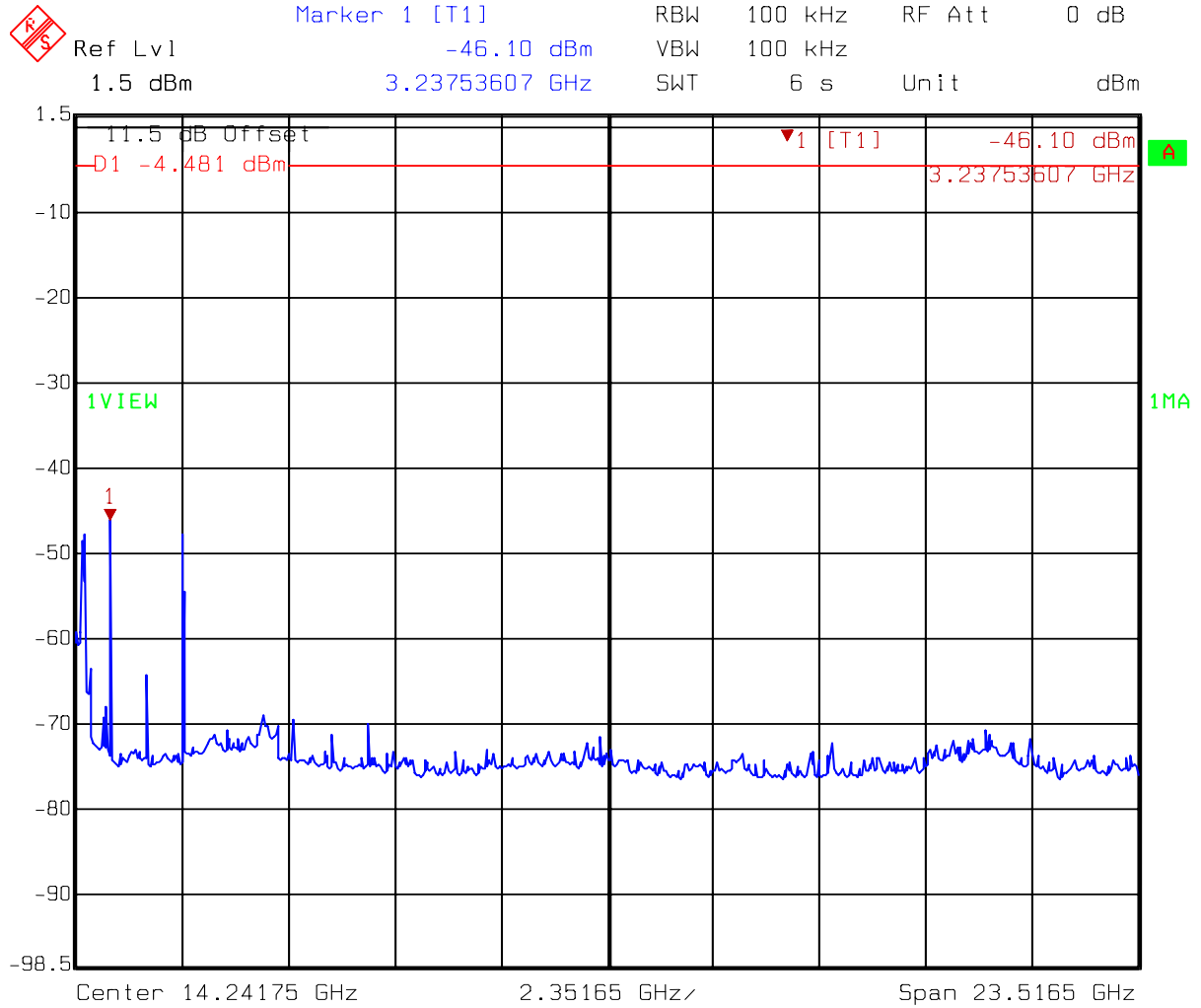

Title: Spurious
 Comment A: CH 40 at Bluetooth mode
 Date: 11.SEP.2006 10:17:37

Test mode: 8DPSK at CH79

	Ref Lvl	-8.5 dBm	Marker 1 [T1]	RBW	100 kHz	RF Att	0 dB
				VBW	100 kHz	Unit	dBm
			2.35250501 GHz	SWT	600 ms		

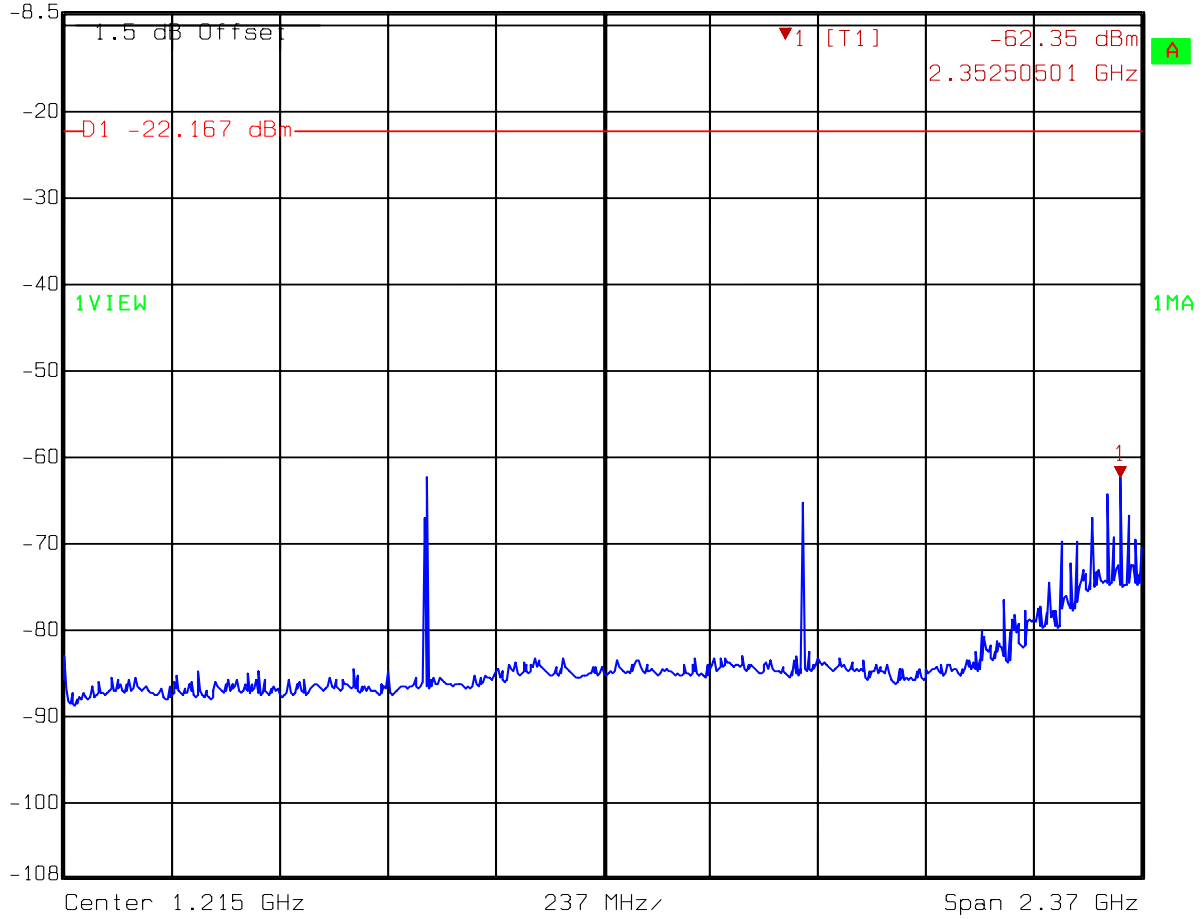

Title: Spurious
 Comment A: CH 79 at Bluetooth mode
 Date: 11.SEP.2006 10:14:22

Test mode: 8DPSK at CH79

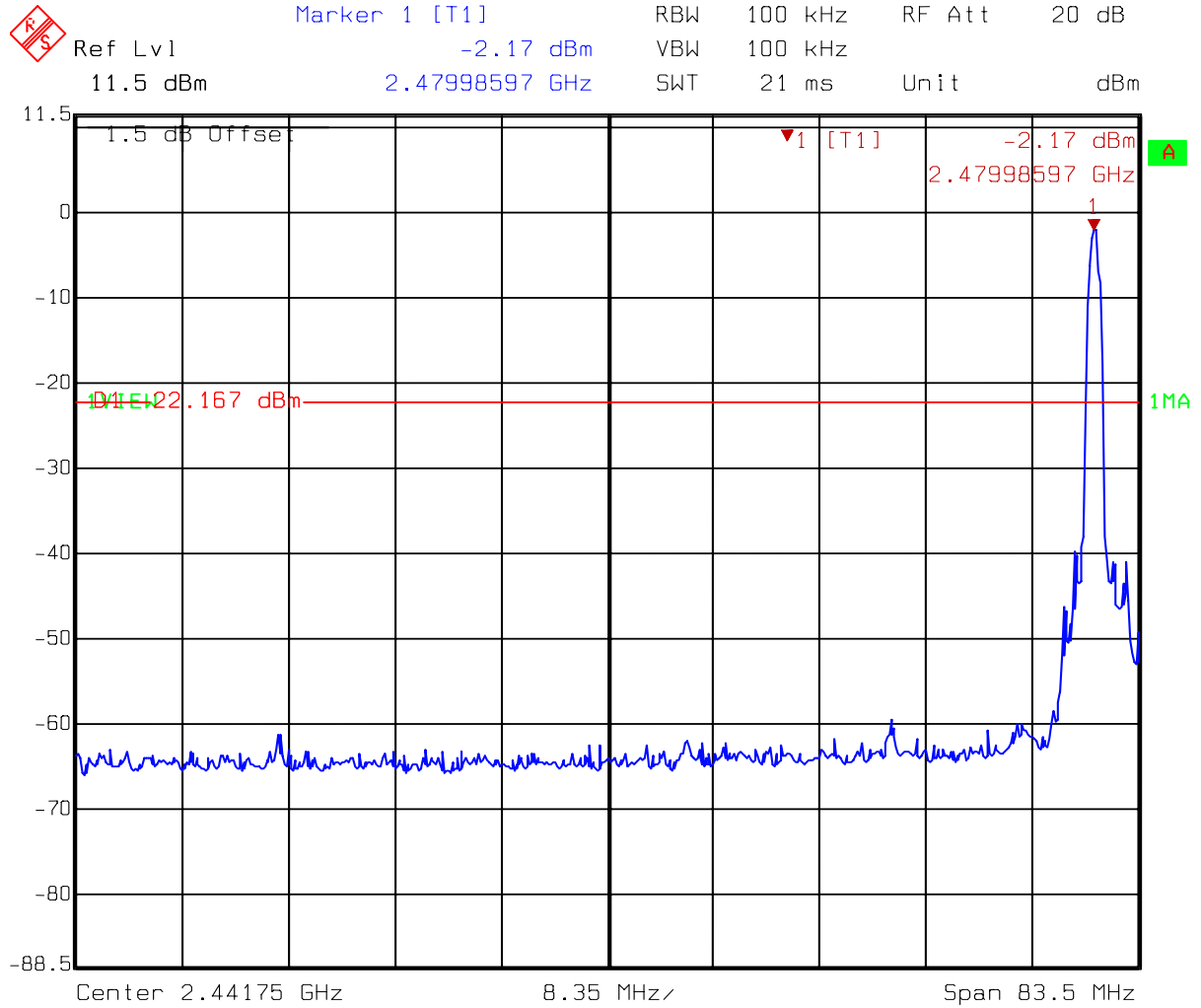

Title: Spurious
 Comment A: CH 79 at Bluetooth mode
 Date: 11.SEP.2006 10:14:01

Test mode: 8DPSK at CH 79

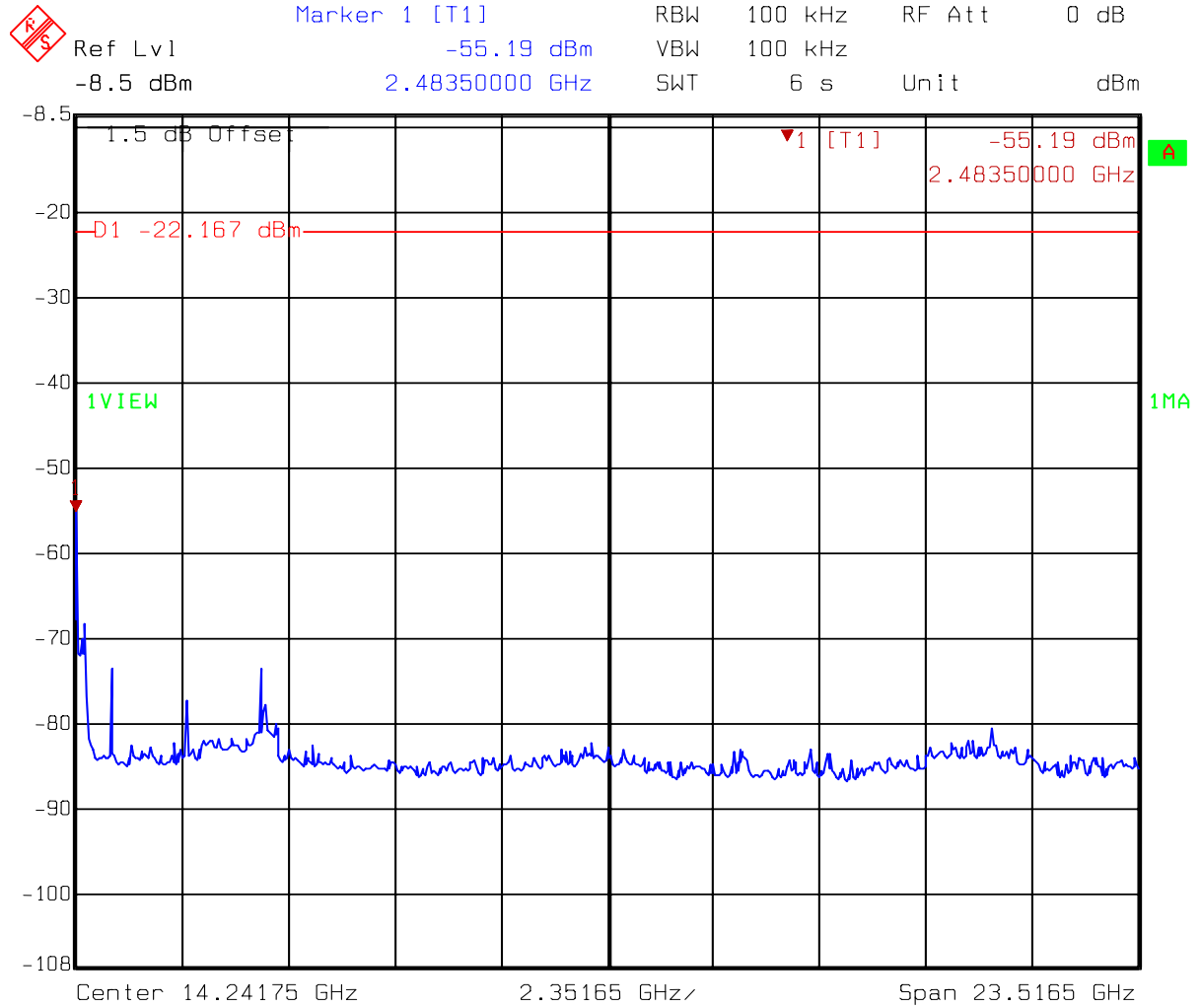

Title: Spurious
 Comment A: CH 79 at Bluetooth mode
 Date: 11.SEP.2006 10:14:49

9. Radiated Emission test

9.1 Operating environment

Temperature: 25
Relative Humidity: 53 %
Atmospheric Pressure: 1023 hPa

9.2 Test setup & procedure

The Diagram below shows the test setup, which is utilized to make these measurements.

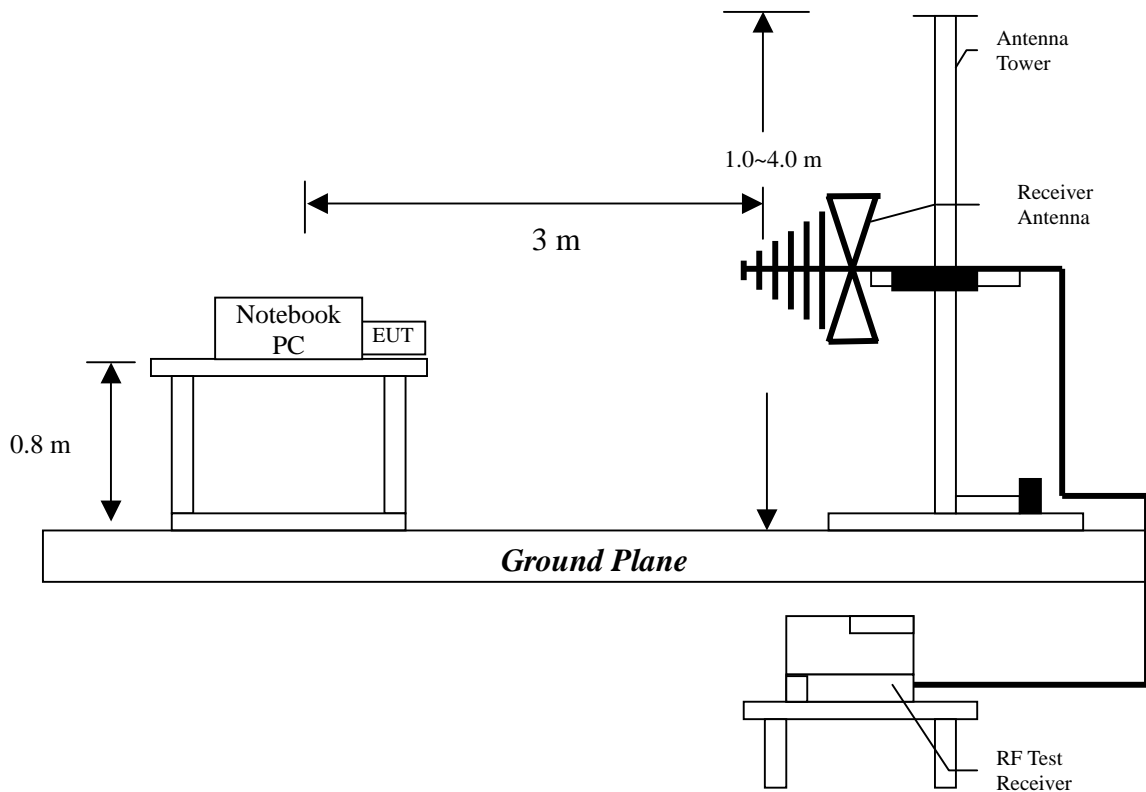

Radiated emissions were investigated cover the frequency range from 30MHz to 1000MHz using a receiver RBW of 120kHz record QP reading, and the frequency over 1GHz using a spectrum analyzer RBW of 1MHz and 10Hz VBW record Average reading. (15.209 paragraph), the Peak reading (1MHz RBW/VBW) recorded also on the report.

The EUT for testing is arranged on a wooden turntable. If some peripherals apply to the EUT, the peripherals will be connected to EUT and the whole system. During the test, all cables were arranged to produce worst-case emissions. The signal is maximized through rotation. The height of antenna and polarization is changing constantly for exploring for maximum signal level. The height of antenna can be up to 4 meters and down to 1 meter.

The measurement for radiated emission will be done at the distance of three meters unless the signal level is too low to measure at that distance. In the case of the reading under noise floor, a pre-amplifier is used and/or the test is conducted at a closer distance. And then all readings are extrapolated back to the equivalent 3 meter reading using inverse scaling with distance.

The EUT configuration please refer to the “Spurious set-up photo.pdf”.

9.3 Emission limits

The spurious Emission shall test through the 10th harmonic. In addition, radiated emissions which fall in the restricted bands, as defined in §15.205(a), must also comply with the radiated emission limits specified in §15.209(a).

Frequency (MHz)	Limits (dB μ V/m@3m)
30-88	40
88-216	43.5
216-960	46
Above 960	54

Remark:

1. In the above table, the tighter limit applies at the band edges.
2. Distance refers to the distance in meters between the measuring instrument antenna and the closed point of any part of the device or system

Uncertainty was calculated in accordance with NAMAS NIS 81.

Expanded uncertainty (k=2) of radiated emission measurement is +/- 4.68 dB.

9.4 Radiated spurious emission test data

9.4.1 Measurement results: frequencies equal to or less than 1 GHz

All modes of GFSK, DQPSK and 8DPSK were verified, the worst case occurred at GFSK mode.

EUT : BTD-430
 Worst Case: : GFSK for CH0

Antenna Polariz. (V/H)	Freq. (MHz)	Receiver Detector	Corr. Factor (dB/m)	Reading (dBuV)	Corrected Level (dBuV/m)	Limit @ 3 m (dBuV/m)	Margin (dB)
V	99.84	QP	7.38	28.92	36.30	43.50	-7.21
V	134.76	QP	11.39	23.55	34.94	43.50	-8.56
V	165.80	QP	15.70	23.15	38.85	43.50	-4.65
V	232.73	QP	12.18	25.77	37.95	46.00	-8.05
V	431.58	QP	17.64	18.80	36.44	46.00	-9.56
V	463.59	QP	17.68	19.01	36.69	46.00	-9.31
H	97.90	QP	7.93	31.29	39.22	43.50	-4.29
H	232.73	QP	11.74	27.33	39.07	46.00	-6.93
H	332.64	QP	14.40	24.10	38.50	46.00	-7.51
H	431.58	QP	18.12	23.38	41.50	46.00	-4.50

Remark:

1. Corr. Factor = Antenna Factor + Cable Loss
2. Corrected Level = Reading + Corr. Factor

9.4.2 Measurement results: frequency above 1GHz

EUT: BTD-430
Test Condition: Tx at channel 0

Test Result:
No spurious emission was found above the spectrum analyzer's noise floor.

The noise floor are listed as below:

For PK:
1GHz to 3 GHz: 20dBuV
3GHz to14 GHz: 27dBuV
14GHz to 26.5 GHz: 39dBuV

For AV:
1 GHz to3GHz: 10dBuV
3 GHz to GHz: 16dBuV
14 GHz to 26.5GHz: 28dBuV

EUT: BTD-430

Test Condition: Tx at channel 40

Test Result:

No spurious emission was found above the spectrum analyzer's noise floor.

The noise floor are listed as below:

For PK:

1GHz to 3 GHz: 20dBuV

3GHz to14 GHz: 27dBuV

14GHz to 26.5 GHz: 39dBuV

For AV:

1 GHz to3GHz: 10dBuV

3 GHz to GHz: 16dBuV

14 GHz to 26.5GHz: 28dBuV

EUT: BTD-430
Test Condition: Tx at channel 79

Test Result:

No spurious emission was found above the spectrum analyzer's noise floor.

The noise floor are listed as below:

For PK:

1GHz to 3 GHz: 20dBuV
3GHz to14 GHz: 27dBuV
14GHz to 26.5 GHz: 39dBuV

For AV:

1 GHz to3GHz: 10dBuV
3 GHz to GHz: 16dBuV
14 GHz to 26.5GHz: 28dBuV

10. Emission on the band edge

In any 100kHz bandwidth outside the frequency band in which the spread spectrum intentional radiator is operating, the radio frequency power that is produced by the intentional radiator shall be at least 20 dB below that in the 100 KHz bandwidth within the band that contains the highest level of the desired power, based on either an RF conducted or a radiated measurement.

10.1 Operating environment

Temperature:	25	
Relative Humidity:	56	%
Atmospheric Pressure	1023	hPa

10.2 Test setup & procedure

The output of EUT was connected to spectrum analyzer via a 50ohm cable.

The setting of spectrum analyzer is:

Peak:	RBW = 100kHz ;	VBW = 100kHz
Average:	RBW = 1MHz ;	VBW = 10Hz

10.3 Test Result

10.3.1 Conducted Method

Test mode: GFSK at CH 1

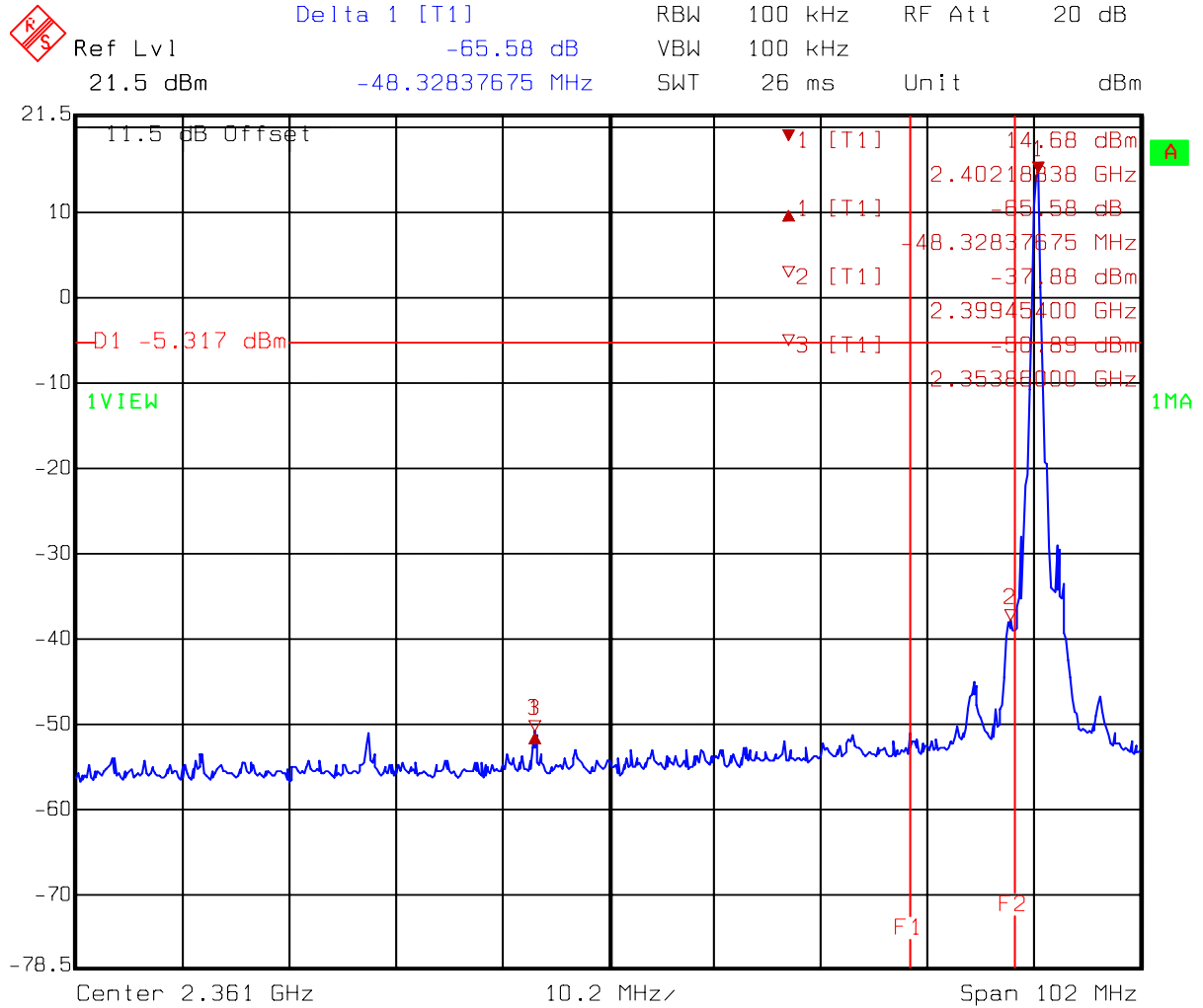

Title: Band-edge
 Comment A: CH 1 at Bluetooth mode (PK)
 Date: 11.SEP.2006 09:46:27

Test mode: GFSK at CH 1

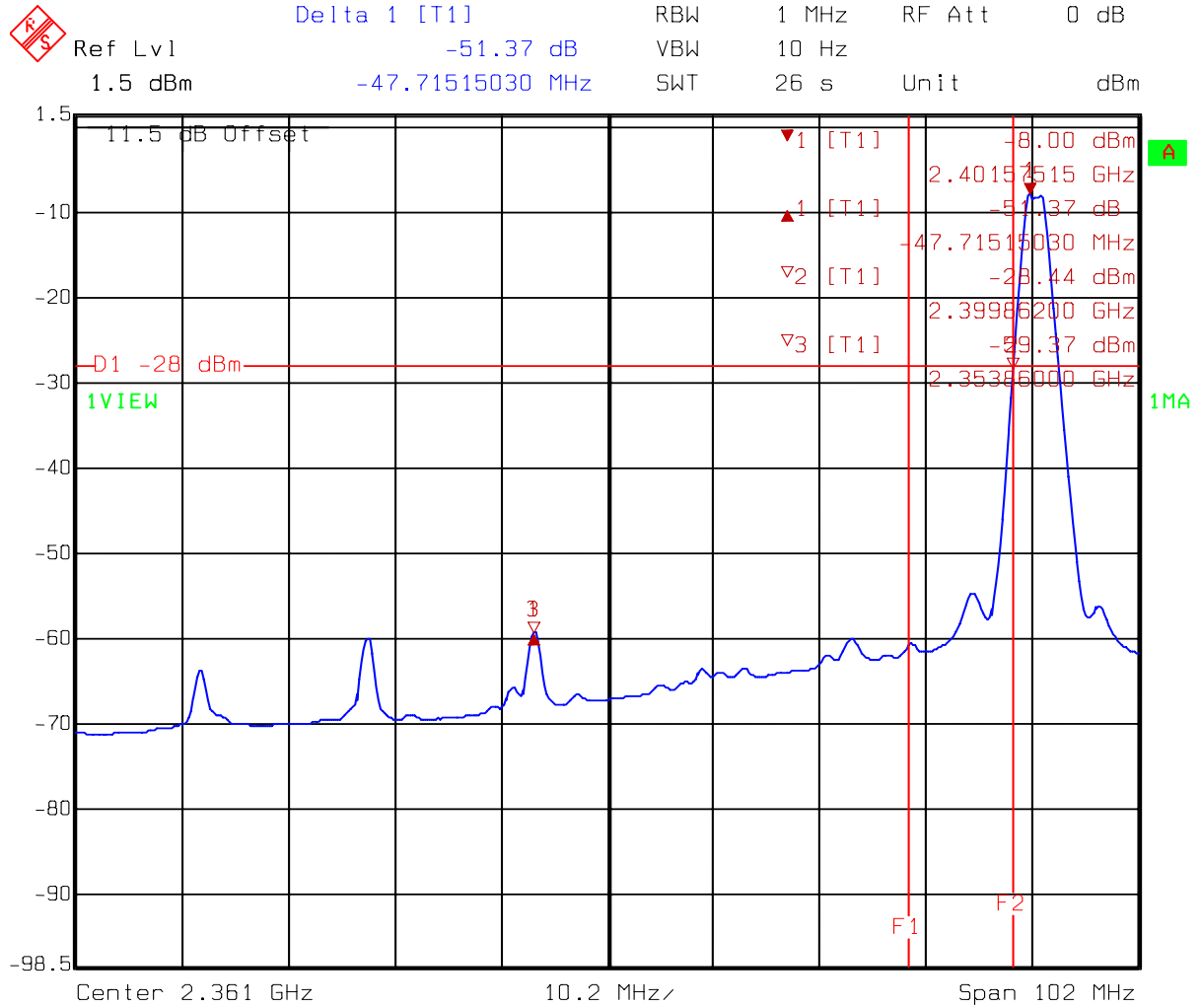

Title: Band-edge
 Comment A: CH 1 at Bluetooth mode (AV)
 Date: 11.SEP.2006 09:48:07

Test mode: GFSK at CH 79

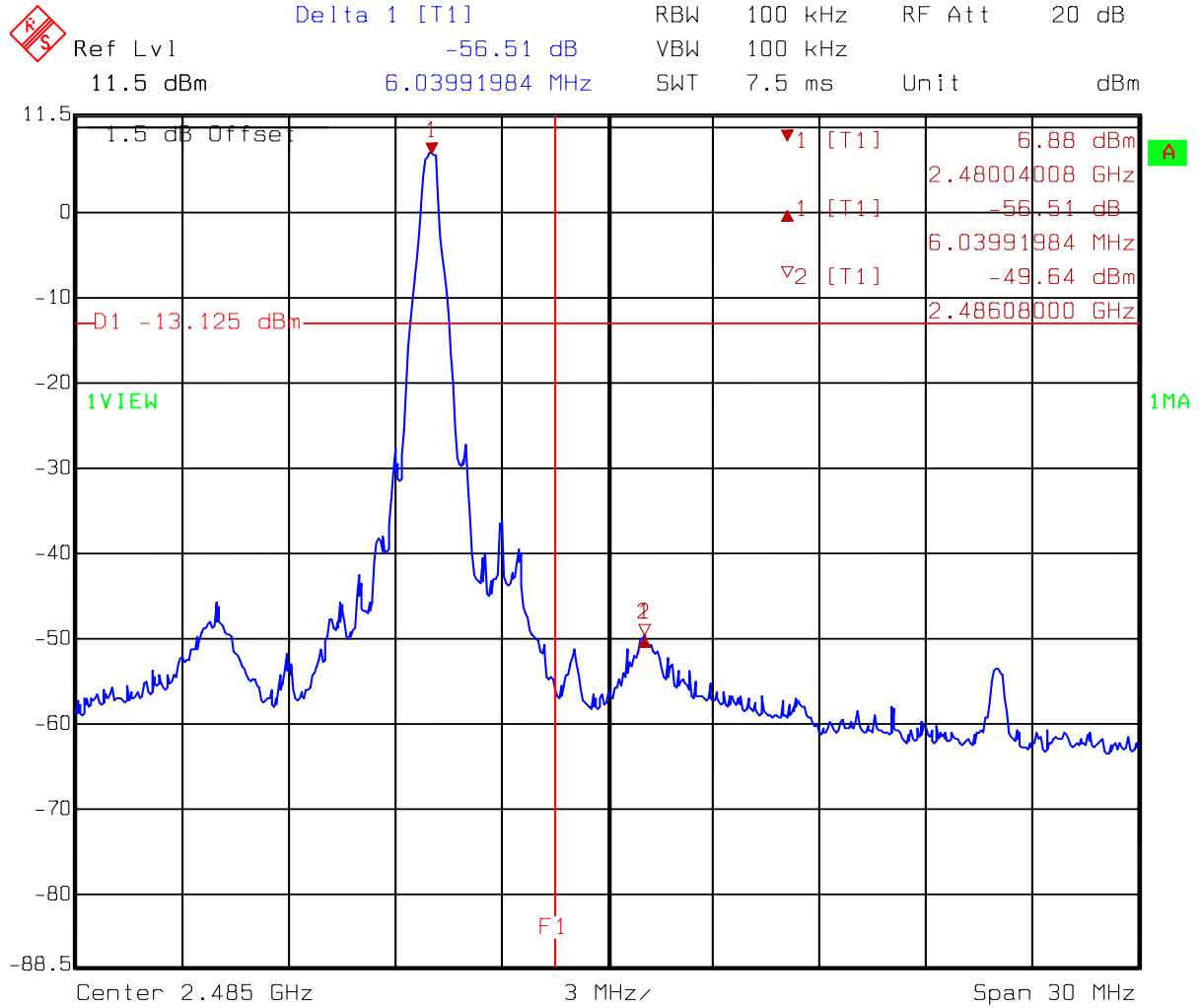

Title: Band-edge
 Comment A: CH 79 at Bluetooth mode (PK)
 Date: 11.SEP.2006 09:38:35

Test mode: GFSK at CH 79

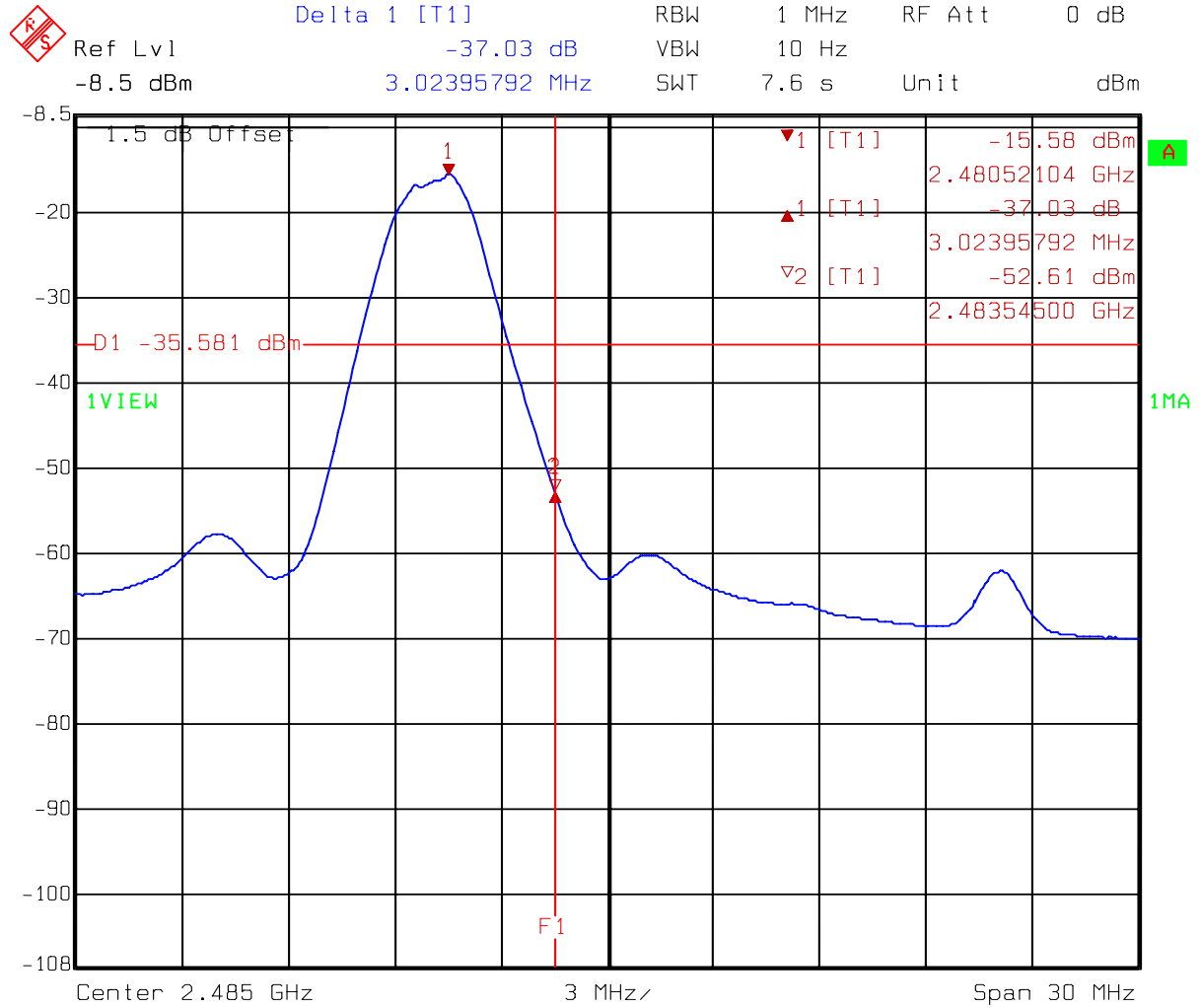

Title: Band-edge
 Comment A: CH 79 at Bluetooth mode (AV)
 Date: 11.SEP.2006 09:39:12

Test mode: DQPSK at CH 1

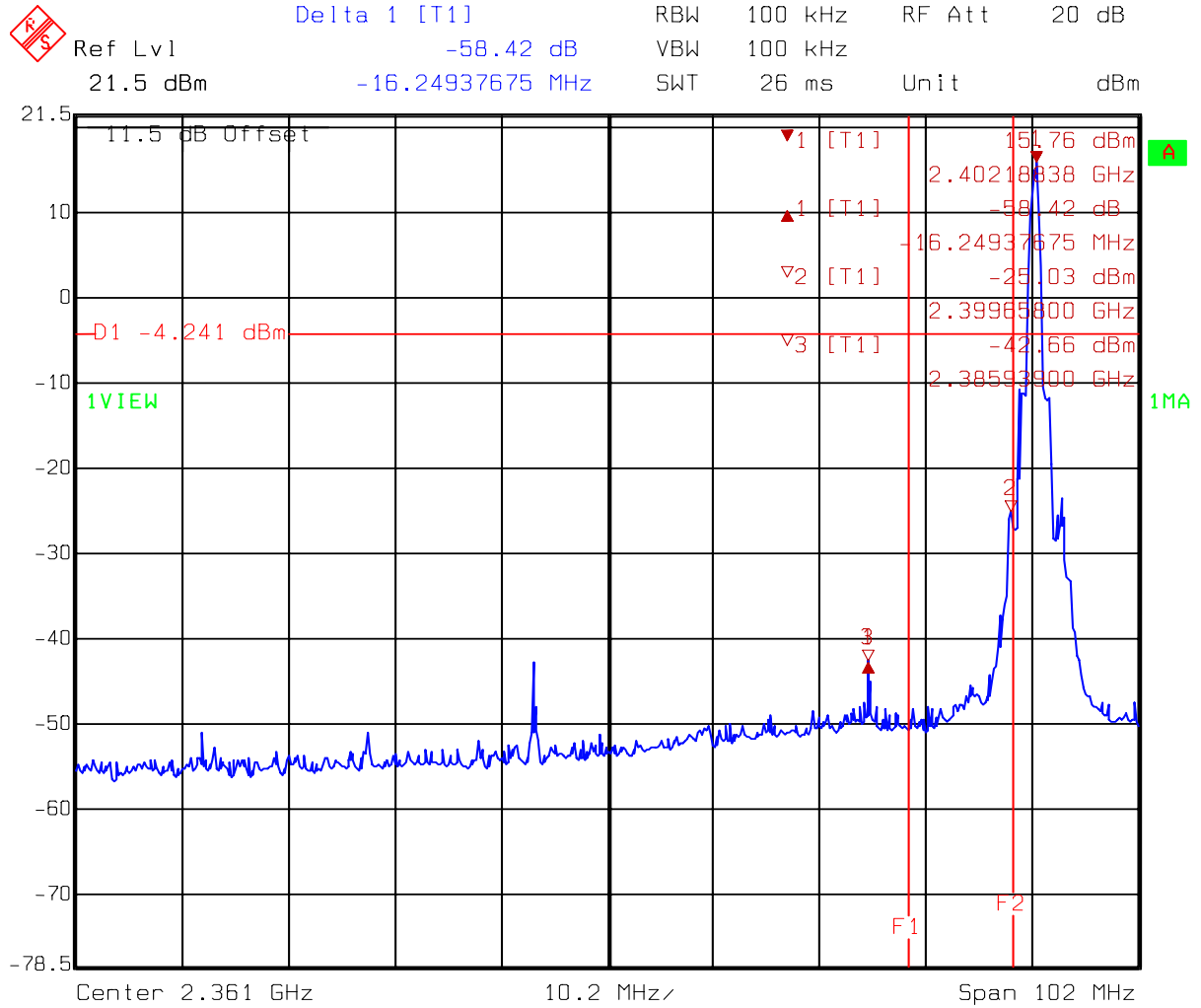

Title: Band-edge
 Comment A: CH 1 at Bluetooth mode (PK)
 Date: 11.SEP.2006 10:00:03

Test mode: DQPSK at CH 1

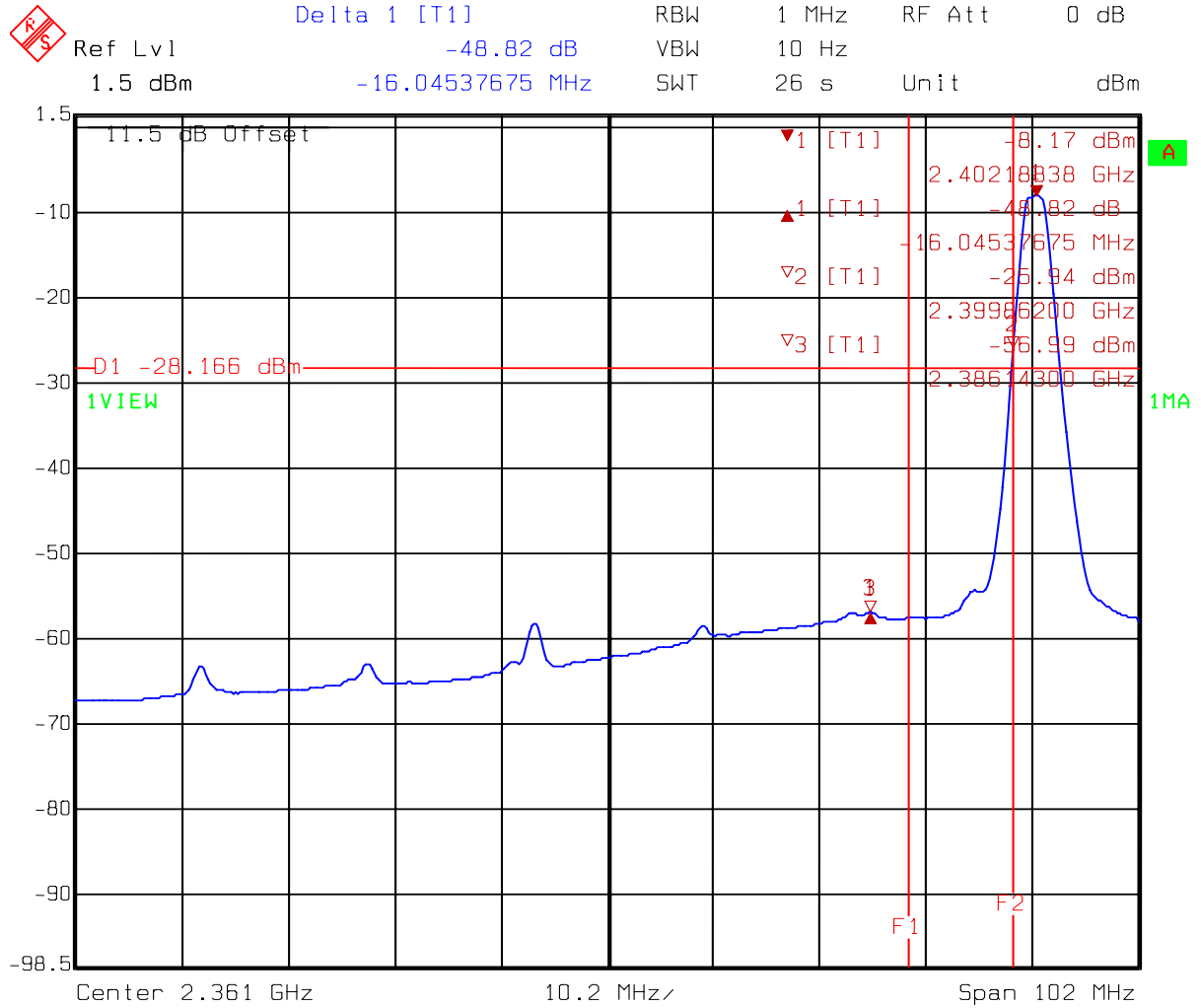

Title: Band-edge
 Comment A: CH 1 at Bluetooth mode (AV)
 Date: 11.SEP.2006 10:01:24

Test mode: DQPSK at CH 79

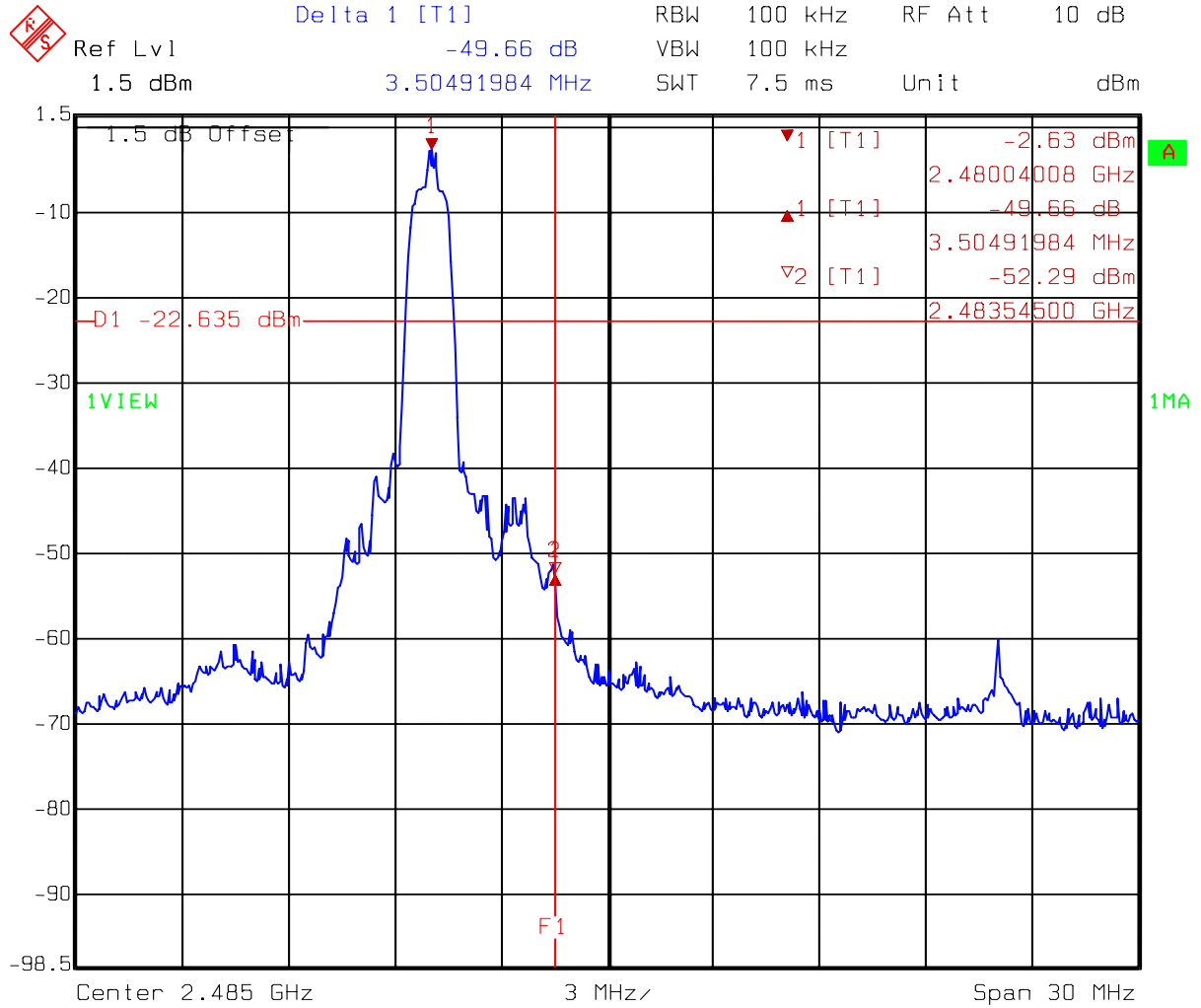

Title: Band-edge
 Comment A: CH 79 at Bluetooth mode (PK)
 Date: 11.SEP.2006 10:07:17

Test mode: DQPSK at CH 79

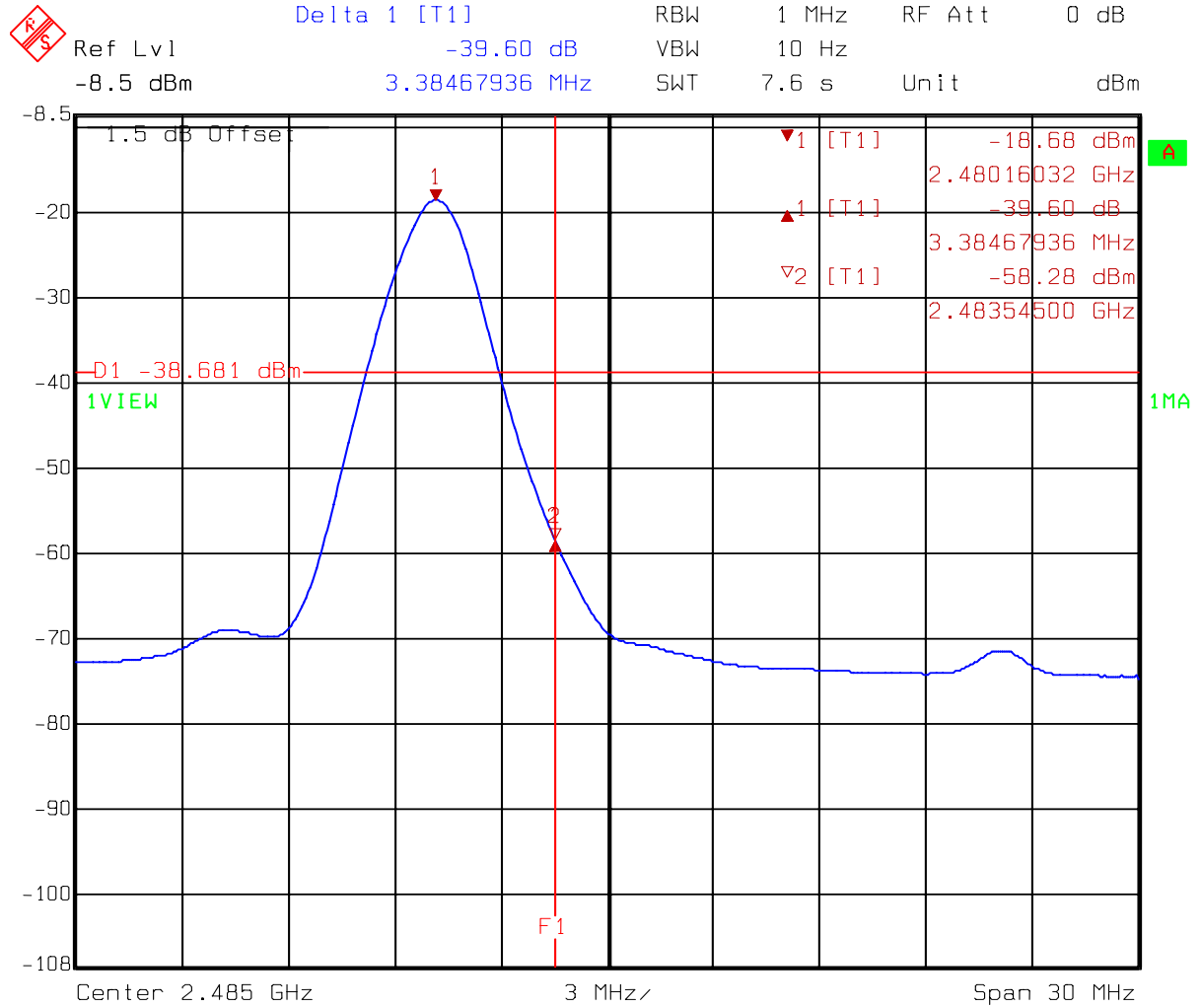

Title: Band-edge
 Comment A: CH 79 at Bluetooth mode (AV)
 Date: 11.SEP.2006 10:07:54

Test mode: 8DPSK at CH 1

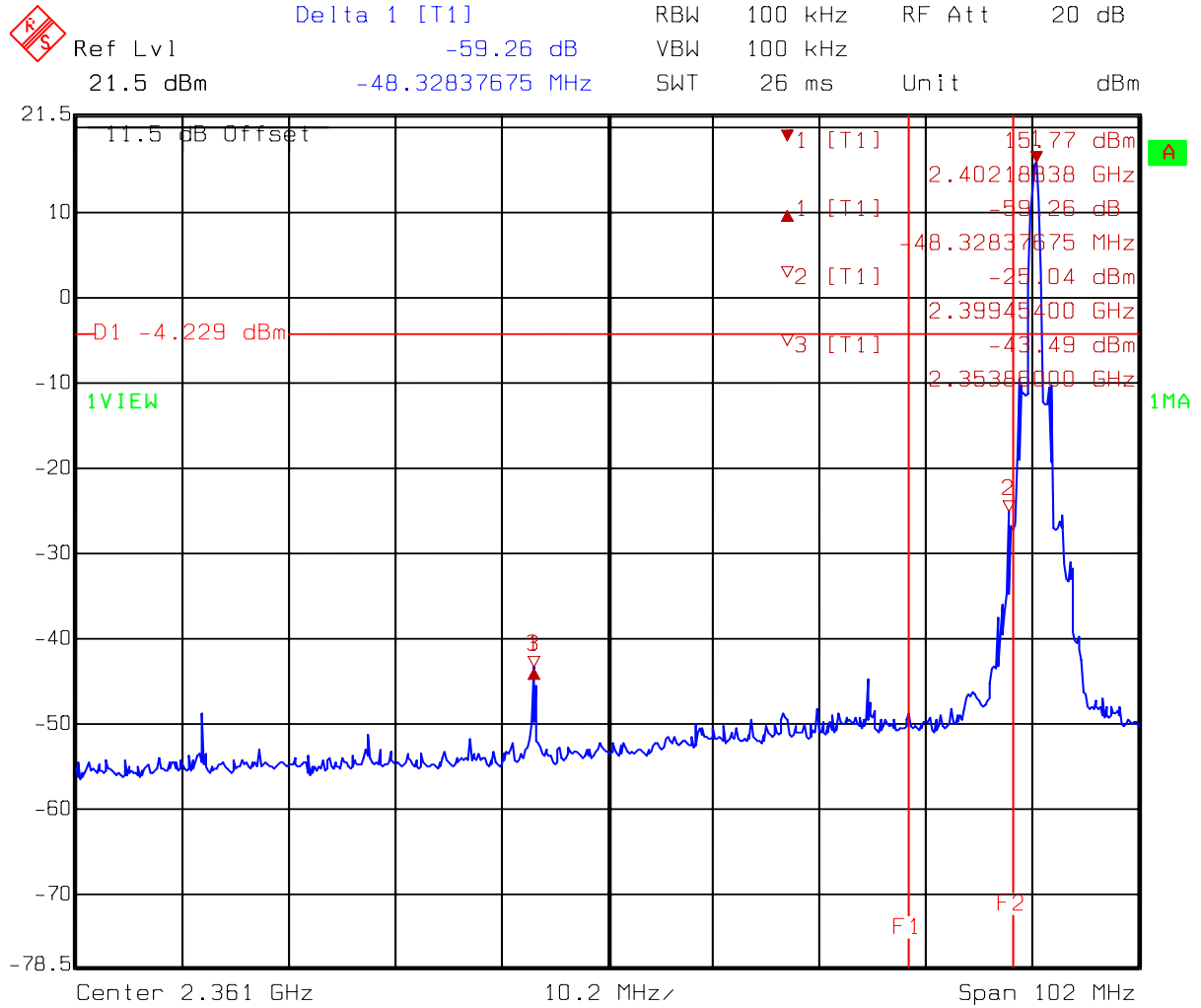

Title: Band-edge
 Comment A: CH 1 at Bluetooth mode (PK)
 Date: 11.SEP.2006 10:19:10

Test mode: 8DPSK at CH 79

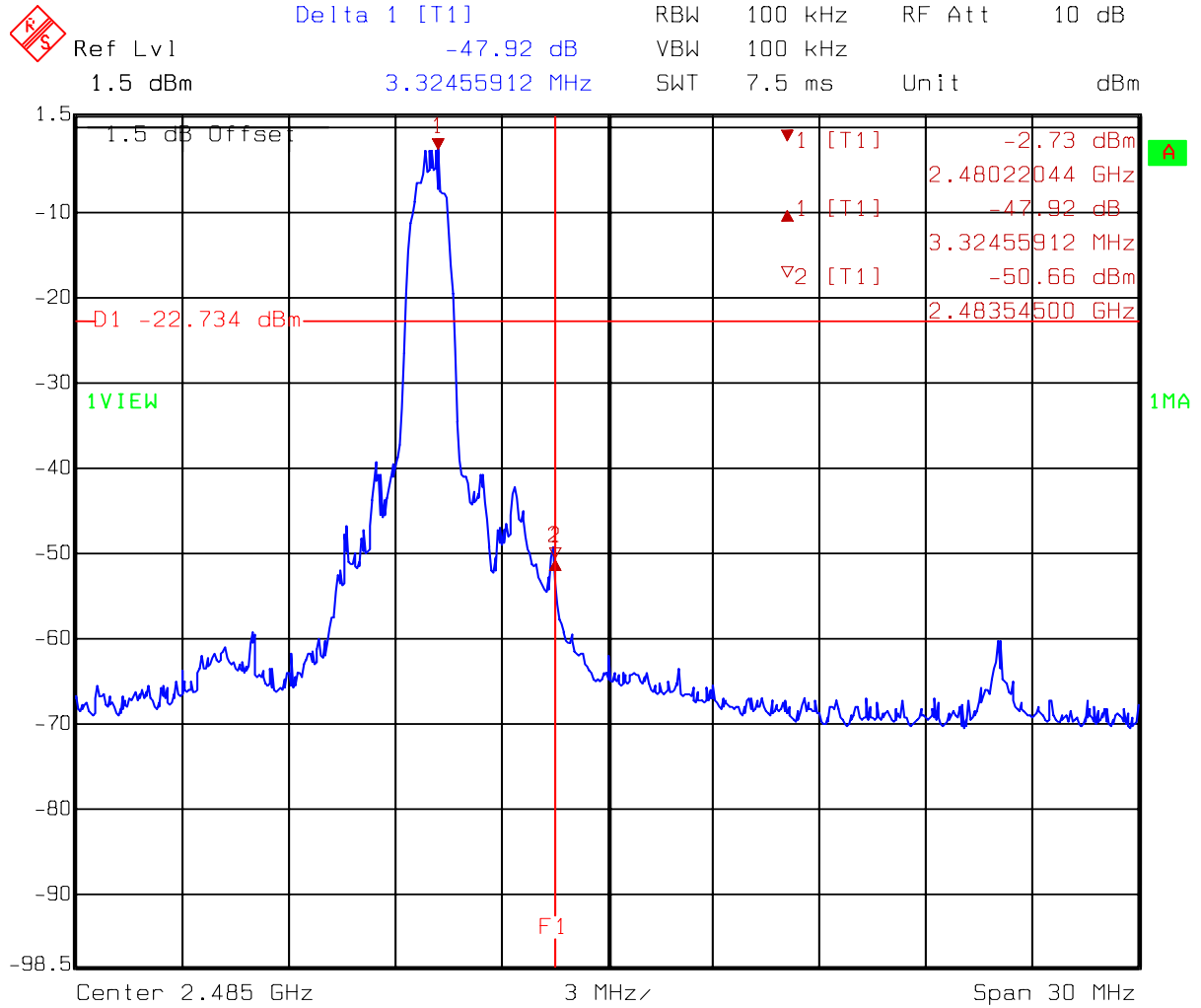

Title: Band-edge
 Comment A: CH 79 at Bluetooth mode (PK)
 Date: 11.SEP.2006 10:12:46

Test mode: 8DPSK at CH 79

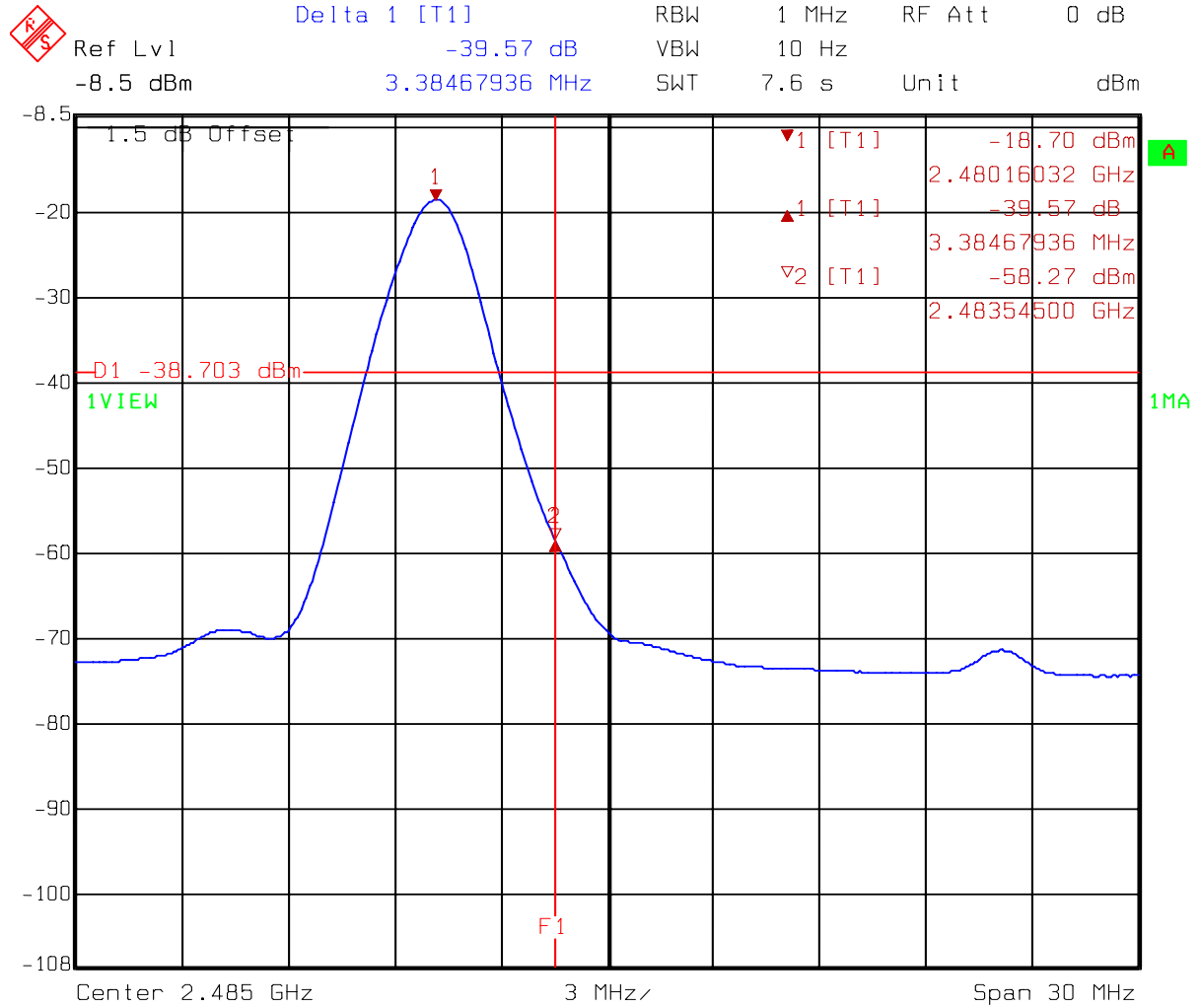

Title: Band-edge
 Comment A: CH 79 at Bluetooth mode (AV)
 Date: 11.SEP.2006 10:13:30

10.3.2 Radiated Method

Test Mode: GFSK

Channel	Detector	Radiated Method	Conducted Method	The Max. Field Strength in Restrict Band (dBuV/m)	Limit @ 3 m (dBuV/m)	Margin (dB)
		Max. Field Strength of Fundamental @3m (dBuV/m)	Between Carrier Max. Power and Local Max. Emission in Restrict Band (dBc)			
		A	B			
1 (lowest)	PK	115.57	56.58	58.99	74	-15.01
	AV	103.52	51.37	52.15	54	-1.85
79 (highest)	PK	109.74	56.51	53.23	74	-20.77
	AV	89.81	37.03	52.78	54	-1.22

Remark: 1. $C = A - B$

2. $E = C - D$

Test Mode: DQPSK

Channel	Detector	Radiated Method	Conducted Method	The Max. Field Strength in Restrict Band (dBuV/m)	Limit @ 3 m (dBuV/m)	Margin (dB)
		Max. Field Strength of Fundamental @3m (dBuV/m)	Between Carrier Max. Power and Local Max. Emission in Restrict Band (dBc)			
		A	B			
1 (lowest)	PK	116.39	58.42	57.97	74	-16.03
	AV	101.2	48.82	52.38	54	-1.62
79 (highest)	PK	100.46	49.66	50.8	74	-23.2
	AV	91.69	39.6	52.09	54	-1.91

Remark: 1. $C = A - B$
 2. $E = C - D$

Test Mode: 8DPSK

Channel	Detector	Radiated Method	Conducted Method	The Max. Field Strength in Restrict Band (dBuV/m)	Limit @ 3 m (dBuV/m)	Margin (dB)
		Max. Field Strength of Fundamental @3m (dBuV/m)	Between Carrier Max. Power and Local Max. Emission in Restrict Band (dBc)			
		A	B			
1 (lowest)	PK	116.32	59.26	57.06	74	-16.94
	AV	101.8	48.83	52.97	54	-1.03
79 (highest)	PK	101.12	47.92	53.2	74	-20.8
	AV	92.18	39.57	52.61	54	-1.39

Remark: 1. $C = A - B$
 2. $E = C - D$

11. Conducted Emission Measurements (FCC 15.107)

11.1 Operating environment

Temperature: 25

Atmospheric Pressure: 1023 hPa

Relative Humidity: 55 %

Test Voltage: 120Vac, 60Hz

11.2 Test Setup and procedure

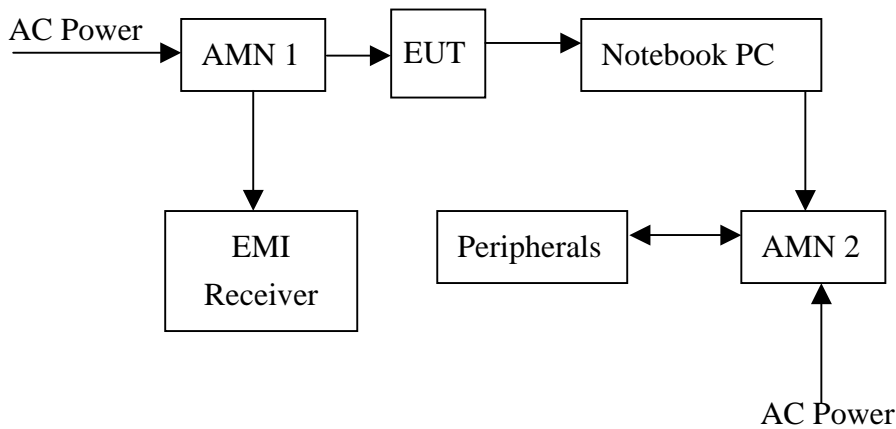

The EUT along with its peripherals were placed on a 1.0m(W)×1.5m(L) and 0.8m in height wooden table and the EUT was adjusted to maintain a 0.4meter space from a vertical reference plane. The EUT was connected to power mains through a line impedance stabilization network (LISN), which provided 50 ohm coupling impedance for measuring instrument and the chassis ground was bounded to the horizontal ground plane of shielded room. The excess power cable between the EUT and the LISN was bundled. All connecting cables of EUT and peripherals were moved to find the maximum emission

11.3 Test Equipment

Equipment	Brand	Model No.	Intertek ID No.	Next Cal. Date
EMI Receiver	Rohde & Schwarz	ESCS 30	EC318	06/15/2007
LISN	Rohde & Schwarz	EHS3-Z5	EC320	12/19/2006
LISN	Schaffner	MN2050D	EC384	03/13/2007
Shield Room	N/A	N/A	N/A	N/A

Note: The above equipments are within the valid calibration period.

11.4 Conducted Emission Limits:

Freq. (MHz)	Maximum RF Line Voltage			
	Class A (dB μ V)		Class B (dB μ V)	
	Q.P.	Avg.	Q.P.	Avg.
0.15~0.50	79	66	66~56	56~46
0.50~5.00	73	60	56	46
5.00~30.0	73	60	60	50

11.5 Uncertainty of Conducted Emission

Expanded uncertainty (k=2) of conducted emission measurement is +/-2.26 dB.

11.6 Conducted Emission Data

Phase: Line
 Model No.: BTD-430
 Test Condition: Normal operating mode

Freq	Pol/Phase	Factor	Read Level	Level	Limit Line	Over Limit	Remark
MHz		dB	dBuV	dBuV	dBuV	dB	
0.36	LINE	0.10	49.01	49.11	58.75	-9.64	QP
0.36	LINE	0.10	44.15	44.25	48.75	-4.50	AVERAGE
0.48	LINE	0.10	44.66	44.76	56.27	-11.51	QP
0.48	LINE	0.10	35.67	35.77	46.27	-10.50	AVERAGE
0.60	LINE	0.10	34.50	34.60	46.00	-11.40	AVERAGE
0.60	LINE	0.10	44.35	44.45	56.00	-11.55	QP
0.73	LINE	0.10	44.72	44.82	56.00	-11.18	QP
0.73	LINE	0.10	32.37	32.47	46.00	-13.53	AVERAGE
0.84	LINE	0.10	42.45	42.55	56.00	-13.45	QP
0.84	LINE	0.10	34.33	34.43	46.00	-11.57	AVERAGE
0.96	LINE	0.10	44.13	44.23	56.00	-11.77	QP
0.96	LINE	0.10	34.55	34.65	46.00	-11.35	AVERAGE
1.07	LINE	0.11	44.16	44.27	56.00	-11.73	QP
1.07	LINE	0.11	35.10	35.21	46.00	-10.79	AVERAGE
1.31	LINE	0.14	43.91	44.05	56.00	-11.95	QP
1.31	LINE	0.14	32.68	32.82	46.00	-13.18	AVERAGE

Remark:

1. Corr. Factor (dB) = LISN Factor (dB) + Cable Loss (dB)
2. Margin (dB) = Level (dBuV) - Limit (dBuV)

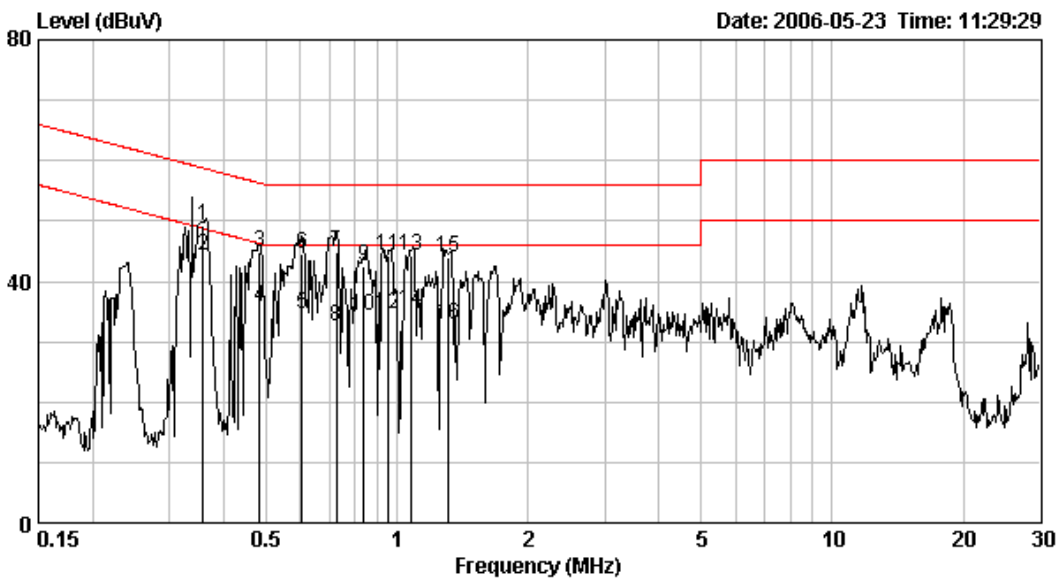

Phase: Neutral
 Model No.: BTD-430
 Test Condition: Normal operating mode

Freq	Pol/Phase	Factor	Read Level	Level	Limit	Over	Remark
MHz		dB	dBuV	dBuV	dBuV	dB	
0.36	NEUTRAL	0.10	50.40	50.50	58.83	-8.33	QP
0.36	NEUTRAL	0.10	44.20	44.30	48.83	-4.53	AVERAGE
0.48	NEUTRAL	0.10	45.32	45.42	56.40	-10.98	QP
0.48	NEUTRAL	0.10	36.89	36.99	46.40	-9.41	AVERAGE
0.59	NEUTRAL	0.10	45.28	45.38	56.00	-10.62	QP
0.59	NEUTRAL	0.10	38.56	38.66	46.00	-7.34	AVERAGE
0.72	NEUTRAL	0.10	46.79	46.89	56.00	-9.11	QP
0.72	NEUTRAL	0.10	36.19	36.29	46.00	-9.71	AVERAGE
0.83	NEUTRAL	0.10	43.05	43.15	56.00	-12.85	QP
0.83	NEUTRAL	0.10	33.08	33.18	46.00	-12.82	AVERAGE
0.95	NEUTRAL	0.10	44.87	44.97	56.00	-11.03	QP
0.95	NEUTRAL	0.10	33.16	33.26	46.00	-12.74	AVERAGE
1.07	NEUTRAL	0.10	45.08	45.18	56.00	-10.82	QP
1.07	NEUTRAL	0.10	32.62	32.72	46.00	-13.28	AVERAGE
1.31	NEUTRAL	0.10	44.87	44.97	56.00	-11.03	QP
1.31	NEUTRAL	0.10	31.85	31.95	46.00	-14.05	AVERAGE

Remark:

1. Corr. Factor (dB)= LISN Factor (dB) + Cable Loss (dB)
2. Margin (dB) = Level (dBuV) – Limit (dBuV)

