



**FCC 47 CFR PART 15 SUBPART C AND ANSI C63.4 : 2003**

**TEST REPORT**

**For**

**Vodafone Bluetooth Headset**

**Model : VF-BTHS-FLK-001**

**Trade Name : Vodafone**

**Issued for**

**Cheng Uei Precision Industry Co., Ltd.**

**No.18, Chung Shan Rd., Tu Cheng City, Taipei Hsien 114, Taiwan, R.O.C.**

**Issued by**

**Compliance Certification Services Inc.**

**Tainan Laboratory**

No. 8, Jiu Cheng Ling, Jiaokeng Village, Sinhua  
Township, Tainan Hsien 712, Taiwan R.O.C.

**TEL: 886-6-580-2201**

**FAX: 886-6-580-2202**



---

*Note: This report shall not be reproduced except in full, without the written approval of Compliance Certification Services Inc. This document may be altered or revised by Compliance Certification Services Inc. personnel only, and shall be noted in the revision section of the document. The client should not use it to claim product endorsement by TAF or any government agencies. The test results in the report only apply to the tested sample.*



## Revision History

| <b>Rev.</b> | <b>Issue Date</b> | <b>Revisions</b> | <b>Effect Page</b> | <b>Revised By</b> |
|-------------|-------------------|------------------|--------------------|-------------------|
| 00          | 08/11/2009        | Initial Issue    | All Page 57        | Jeter Wu          |
|             |                   |                  |                    |                   |
|             |                   |                  |                    |                   |
|             |                   |                  |                    |                   |
|             |                   |                  |                    |                   |



**TABLE OF CONTENTS**

| TITLE  | PAGE NO.     |
|--|--------------|
| <b>1. TEST REPORT CERTIFICATION</b> .....            | <b>4</b>     |
| <b>2. EUT DESCRIPTION</b> .....                      | <b>5</b>     |
| 2.1 DESCRIPTION OF EUT & POWER.....                  | 5            |
| <b>3. DESCRIPTION OF TEST MODES</b> .....            | <b>6</b>     |
| <b>4. TEST METHODOLOGY</b> .....                     | <b>7</b>     |
| <b>5. FACILITIES AND ACCREDITATIONS</b> .....        | <b>8</b>     |
| 5.1 FACILITIES .....                                 | 8            |
| 5.2 EQUIPMENT .....                                  | 8            |
| 5.3 LABORATORY ACCREDITATIONS LISTINGS.....          | 8            |
| 5.4 TABLE OF ACCREDITATIONS AND LISTINGS .....       | 9            |
| <b>6. CALIBRATION AND UNCERTAINTY</b> .....          | <b>10</b>    |
| 6.1 MEASURING INSTRUMENT CALIBRATION .....           | 10           |
| 6.2 MEASUREMENT UNCERTAINTY.....                     | 10           |
| <b>7. SETUP OF EQUIPMENT UNDER TEST</b> .....        | <b>11</b>    |
| <b>8. APPLICABLE LIMITS AND TEST RESULTS</b> .....   | <b>12</b>    |
| 8.1 20dB BANDWIDTH FOR HOPPING.....                  | 12-15        |
| 8.2 MAXIMUM PEAK OUTPUT POWER .....                  | 16-19        |
| 8.3 HOPPING CHANNEL SEPARATION.....                  | 20-22        |
| 8.4 NUMBER OF HOPPING FREQUENCY USED .....           | 23-24        |
| 8.5 DWELL TIME ON EACH CHANNEL .....                 | 25-28        |
| 8.6 CONDUCTED SPURIOUS EMISSION.....                 | 29-31        |
| 8.7 RADIATED EMISSIONS .....                         | 32           |
| 8.7.1 TRANSMITTER RADIATED SUPURIOUS EMSSIONS .....  | 32-35        |
| 8.7.2 WORST-CASE RADIATED EMISSION BELOW 1 GHz.....  | 36-37        |
| 8.7.3 TRANSMITTER RADIATED EMISSION ABOVE 1 GHz..... | 38-40        |
| 8.7.4 RESTRICTED BAND EDGES .....                    | 41-44        |
| 8.8 POWERLINE CONDUCTED EMISSIONS .....              | 45-48        |
| <b>APPENDIX SETUP PHOTOS</b> .....                   | <b>49-57</b> |



# 1. TEST REPORT CERTIFICATION

**Applicant** : Cheng Uei Precision Industry Co., Ltd.  
**Address** : No.18, Chung Shan Rd., Tu Cheng City, Taipei Hsien 114,  
 Taiwan, R.O.C.  
**Equipment Under Test** : Vodafone Bluetooth Headset  
**Model** : VF-BTHS-FLK-001  
**Trade Name** : Vodafone  
**Tested Date** : July 22 ~ August 07, 2009

| APPLICABLE STANDARD                            |             |
|--|-------------|
| STANDARD                                       | TEST RESULT |
| FCC Part 15 Subpart C AND<br>ANSI C63.4 : 2003 | PASS        |

Approved by:

Jeter Wu  
Section Manager

Reviewed by:

Eric Yang  
Senior Engineer

WE HEREBY CERTIFY THAT: The measurements shown in the attachment were made in accordance with the procedures indicated, and the energy emitted by the equipment was found to be within the limits applicable. We assume full responsibility for the accuracy and completeness of these measurements and vouch for the qualifications of all persons taking them.



## 2. EUT DESCRIPTION

### 2.1 DESCRIPTION OF EUT & POWER

|                                   |  |
|-----------------------------------|--|
| <b>Product Name</b>               | Vodafone Bluetooth Headset   |
| <b>Model Number</b>               | VF-BTHS-FLK-001  |
| <b>Frequency Range</b>            | 2402MHz to 2480MHz $f = 2402 + n\text{MHz}$ , $n = 0, \dots, 78$   |
| <b>Transmit Power</b>             | 3.21 dBm   |
| <b>Channel Spacing</b>            | 1MHz   |
| <b>Channel Number</b>             | 79 Channels  |
| <b>Air Data Rate</b>              | GFSK (1Mbps)   |
| <b>Type of Modulation</b>         | Frequency Hopping Spread Spectrum  |
| <b>Frequency Selection</b>        | by software / firmware   |
| <b>Transmitter Classification</b> | portable device  |
| <b>Antenna Type</b>               | PCB Antenna, Antenna Gain : 1.18dBi  |
| <b>Power Source</b>               | Normal Mode: 3.7VDC ( From Battery Powered)<br>Charge Mode: 5.0VDC (From Notebook PC, Powered From Host Device)  |
| <b>RF Exposure Evaluation</b>     | Since the EUT is classed portable device, and the maximum peak power is 3.21dBm (<13.6dBm), the MPE evaluation is not required and no SAR consideration applied. |
| <b>I/O Port</b>                   | Mini USB Port × 1  |

**Remark:**

1. The sample selected for test was engineering sample that approximated to production product and was provided by manufacturer.
2. This submittal(s) (test report) is intended for FCC ID: QVZ-VFBTHSFLK001 filing to comply with Section 15.207, 15.209 and 15.247 of the FCC Part 15, Subpart C Rules.
3. For more details, please refer to the User's manual of the EUT.



### 3. DESCRIPTION OF TEST MODES

The EUT had been tested under operating condition.

There are three channels have been tested as following :

| Channel | Frequency (MHz) |
|---------|-----------------|
| Low     | 2402            |
| Middle  | 2441            |
| High    | 2480            |

#### **Radiated Emission Test (Below 1 GHz):**

- Pre-Scan has been conducted to determine the worst-case mode from all possible combinations between available modulations, data rates and antenna ports (if EUT with antenna diversity architecture).
- Following channel(s) was (were) selected for the final test as listed below.

Normal Linking / Charge Linking

#### **Radiated Emission Test (Above 1 GHz):**

- Pre-Scan has been conducted to determine the worst-case mode from all possible combinations between available modulations, data rates and antenna ports (if EUT with antenna diversity architecture).
- Following channel(s) was (were) selected for the final test as listed below.

| Tested Channel | Modulation Technology | Modulation Type | Packet Type |
|----------------|-----------------------|-----------------|-------------|
| Low, Mid, High | FHSS                  | GFSK            | DH5         |

#### **Bandedge Measurement :**

- Pre-Scan has been conducted to determine the worst-case mode from all possible combinations between available modulations, data rates and antenna ports (if EUT with antenna diversity architecture).
- Following channel(s) was (were) selected for the final test as listed below.

| Tested Channel | Modulation Technology | Modulation Type | Packet Type |
|----------------|-----------------------|-----------------|-------------|
| Low, High      | FHSS                  | GFSK            | DH5         |

**Antenna Port Conducted Measurement :**

- Pre-Scan has been conducted to determine the worst-case mode from all possible combinations between available modulations, data rates and antenna ports (if EUT with antenna diversity architecture).
- Following channel(s) was (were) selected for the final test as listed below.

| Tested Channel | Modulation Technology | Modulation Type | Packet Type |
|----------------|-----------------------|-----------------|-------------|
| Low, Mid, High | FHSS                  | GFSK            | DH5         |

Note : The field strength of spurious emission was measured in the following position: EUT stand-up position(Z axis), lie-down position(X,Y axis). The worst emission was found in lie-down position(X axis) and the worst case was recorded.

**4. TEST METHODOLOGY**

The tests documented in this report were performed in accordance with ANSI C63.4 : 2003 and FCC CFR 47 15.207, 15.209 and 15.247.



## **5. FACILITIES AND ACCREDITATIONS**

### **5.1 FACILITIES**

All measurement facilities used to collect the measurement data are located at

No. 8, Jiu Cheng Ling, Jiaokeng Village, Sinhua Township, Tainan Hsien 712, Taiwan R.O.C.

The sites are constructed in conformance with the requirements of ANSI C63.7, ANSI C63.4 : 2003 and CISPR Publication 22.

### **5.2 EQUIPMENT**

Radiated emissions are measured with one or more of the following types of linearly polarized antennas: tuned dipole, biconical, log periodic, bi-log, and/or ridged waveguide, horn. Spectrum analyzers with preselectors and quasi-peak detectors are used to perform radiated measurements.

Conducted emissions are measured with Line Impedance Stabilization Networks and EMI Test Receivers.

Calibrated wideband preamplifiers, coaxial cables, and coaxial attenuators are also used for making measurements.







All receiving equipment conforms to CISPR Publication 16-1, "Radio Interference Measuring Apparatus and Measurement Methods."

### **5.3 LABORATORY ACCREDITATIONS LISTINGS**

The test facilities used to perform radiated and conducted emissions tests are accredited by Taiwan Accreditation Foundation for the specific scope of accreditation under Lab Code: 1109 to perform Electromagnetic Interference tests according to FCC PART 15 AND CISPR 22 requirements. In addition, the test facilities are listed with Industry Canada, Certification and Engineering Bureau, IC 2324H-1 for OATS -6.



### 5.4 TABLE OF ACCREDITATIONS AND LISTINGS

| Country | Agency          | Scope of Accreditation  | Logo  |
|---------|-----------------|---|---|
| USA     | FCC             | 3/10 meter Open Area Test Sites to perform FCC Part 15/18 measurements  | <br>TW-1037  |
| Japan   | VCCI            | 3/10 meter Open Area Test Sites to perform conducted/radiated measurements  | <br>C-2882<br>R-2635   |
| Taiwan  | TAF             | CISPR 11, FCC METHOD-47 CFR Part 18, EN 55011, EN 60601-1-2,<br>CISPR 22, CNS 13438, EN 55022, EN 55024, AS/NZS CISPR 22<br>CISPR 14, EN 55014-1, EN 55014-2, CNS 13783-1, CISPR 22,<br>CNS 13439, EN 55013,<br>FCC Method-47 CFR Part 15 Subpart B,<br>IC ICES-003, VCCI V-3 & V-4<br>FCC Method-47 CFR Part 15 Subpart C and ANSI C63.4, LP 0002<br>EN / IEC 61000-4-2 / -3 / -4 / -5 / -6 / -8 / -11<br>EN 61000-3-2, EN 61000-3-3<br>EN 61000-6-3, EN 61000-6-1, AS/NZS 4251.1,<br>EN 61000-6-4, EN 61000-6-2, AS/NZS 4251.2,<br>EN 61204-3, EN 50130-4, EN 62040-2,<br>EN 50371, EN 50385, AS/NZS 4268,<br>ETSI EN 300 386<br>ETSI EN 300 328, ETSI EN 301 489-1/-3/-9/-17<br>ETSI EN 301 893, ETSI EN 300 220-2/-1<br>ETSI EN 300 440-2/-1<br>ETSI EN 301 357-2/-1<br>RSS-310, RSS-210 Issue 7, RSS-Gen Issue 2 |   |
| Taiwan  | BSMI            | CNS 13438, CNS 13783-1, CNS13439  | <br>SL2-IN-E-0039<br>SL2-R1/R2-0039<br>SL2-A1-E-0039                                   |
| Canada  | Industry Canada | RSS210, Issue 7   | <br>IC 2324H-1   |

\* No part of this report may be used to claim or imply product endorsement by TAF or any agency of the US Government.



## 6. CALIBRATION AND UNCERTAINTY

### 6.1 MEASURING INSTRUMENT CALIBRATION

The measuring equipment utilized to perform the tests documented in this report has been calibrated in accordance with the manufacturer's recommendations, and is traceable to recognized national standards.

### 6.2 MEASUREMENT UNCERTAINTY

The following table is for the measurement uncertainty, which is calculated as per the document CISPR 16-4.

| PARAMETER                         | UNCERTAINTY |
|-----------------------------------|-------------|
| Radiated Emission, 30 to 1000 MHz | +/- 3.2 dB  |
| Radiated Emission, 1 to 26.5GHz   | +/- 3.2 dB  |
| Power Line Conducted Emission     | +/- 2.1 dB  |

This uncertainty represents an expanded uncertainty expressed at approximately the 95% confidence level using a coverage factor of k=2.



## 7. SETUP OF EQUIPMENT UNDER TEST

### SUPPORT EQUIPMENT

| No. | Product     | Manufacturer | Model No.    | Serial No. | FCC ID         |
|-----|-------------|--------------|--------------|------------|----------------|
| 1   | Notebook PC | HP           | nx6130       | CNU543274R | CNTWM3B2200BGA |
| 2   | Printer     | HP           | Deskjet 948c | CN19T6S011 | DoC            |
| 3   | Mouse       | KINYO        | KM-770       | 0804       | DoC            |
| 4   | Modem       | ZyXEL        | Omni 56k     | S1Z4107727 | I880MNI56K     |

### SETUP DIAGRAM F SETUP DIAGRAM FOR TESTS

EUT & peripherals setup diagram is shown in appendix setup photos.

### EUT OPERATING CONDITION

#### **RF Mode**

1. Setup all computers like the setup diagram.
2. Run CSR Blue Test software.
3. Select the following settings,  
Transport type: USB  
USB Device:csr0
4. TX mode(GFSK)  
TXDATA1  
LO Freq: 2402, 2441, 2480  
Power (EXT, Int): 255, 43  
CFG PKT, Packet Type: 15  
Packet Size: 339
5. All of the functions are under run.
6. Start test.

#### **Normal Mode:**

1. Setup all computers like the setup diagram.
2. (1) Build up a connection between EUT and Notebook PC (play music).  
(2) Charge mode.
3. All of the functions are under run.
4. Start test.



## 8. APPLICABLE LIMITS AND TEST RESULTS

### 8.1 20dB BANDWIDTH FOR HOPPING

#### LIMIT

Limit : N/A

#### TEST EQUIPMENT

| Name of Equipment | Manufacturer | Model  | Serial Number | Calibration Due |
|-------------------|--------------|--------|---------------|-----------------|
| SPECTRUM ANALYZER | AGILENT      | E4446A | MY43360132    | 06/09/2010      |
| SPECTRUM ANALYZER | AGILENT      | E4446A | MY46180323    | 05/26/2010      |

*Remark: Each piece of equipment is scheduled for calibration once a year.*

#### TEST SETUP

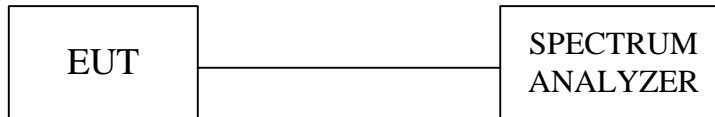

#### TEST PROCEDURE

The 20dB band width was measured with a spectrum analyzer connected to RF antenna connector (conducted measurement) while EUT was operating in transmit mode at the appropriate center frequency. The analyzer center frequency was set to the EUT carrier frequency, using the analyzer. Display Line and Marker Delta functions, the 20dB band width of the emission was determined.



**TEST RESULTS**

**Modulation Type: GFSK, CFG PKT Packet Type: 15 Packet Size: 339 (DH5)**

| <b>Channel</b> | <b>Channel Frequency (MHz)</b> | <b>20dB Bandwidth (MHz)</b> | <b>Pass / Fail</b> |
|----------------|--------------------------------|-----------------------------|--------------------|
| Low            | 2402                           | 0.935                       | N/A                |
| Middle         | 2441                           | 0.935                       | N/A                |
| High           | 2480                           | 0.935                       | N/A                |



**20dB BANDWIDTH**

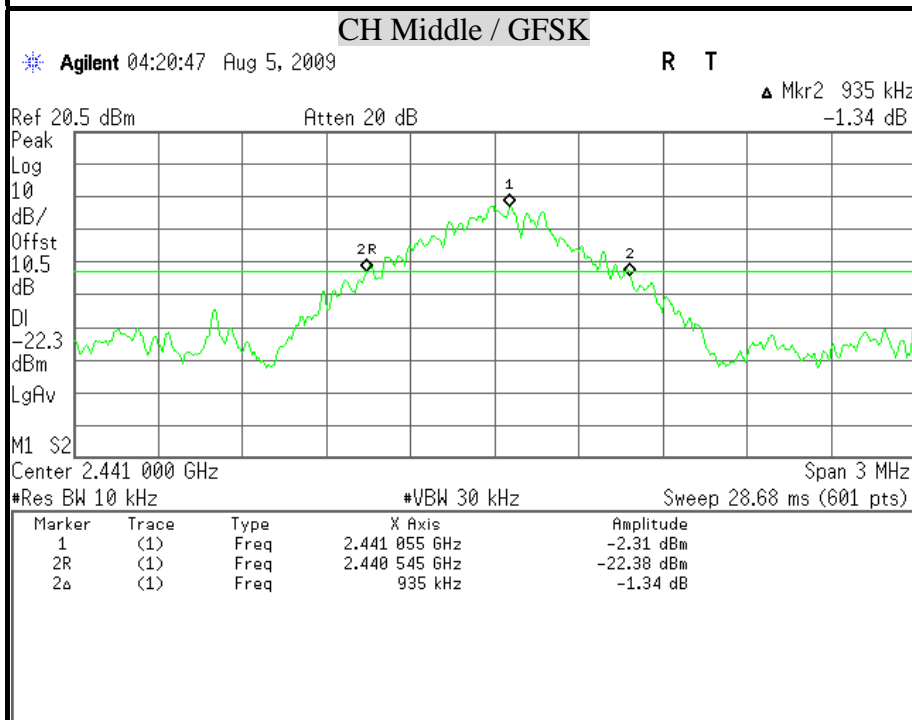
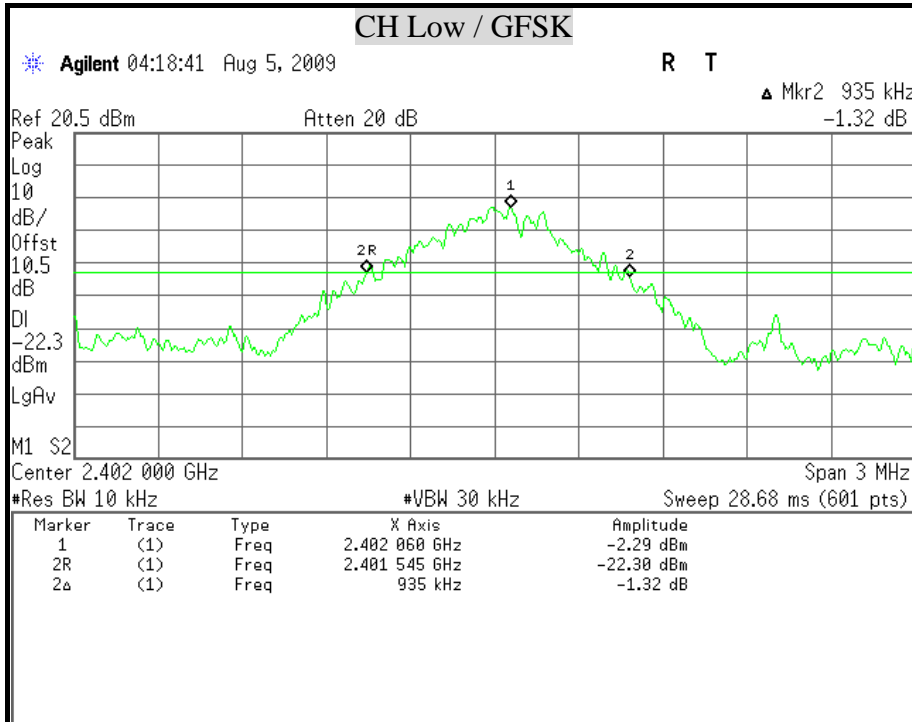

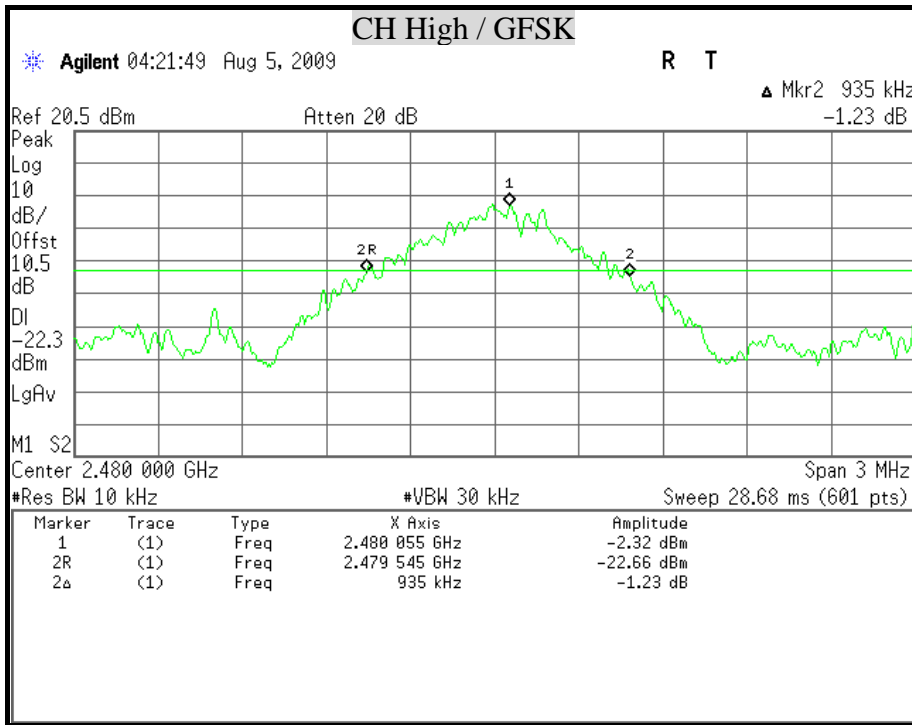



## 8.2 MAXIMUM PEAK OUTPUT POWER

### LIMIT

§15.247(b)(1) For frequency hopping systems operating in the 2400-2483.5 MHz band employing at least 75 non-overlapping hopping channels, and all frequency hopping systems in the 5725-5850 MHz band: 1 watt. For all other frequency hopping systems in the 2400-2483.5 MHz band: 0.125 watts.

### TEST EQUIPMENT

| Name of Equipment | Manufacturer | Model  | Serial Number | Calibration Due |
|-------------------|--------------|--------|---------------|-----------------|
| SPECTRUM ANALYZER | AGILENT      | E4446A | MY43360132    | 06/09/2010      |
| SPECTRUM ANALYZER | AGILENT      | E4446A | MY46180323    | 05/26/2010      |

*Remark: Each piece of equipment is scheduled for calibration once a year.*

### TEST SETUP

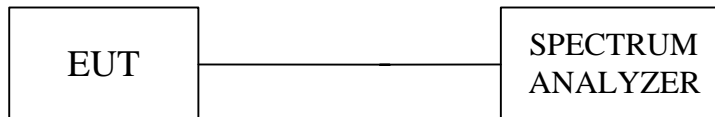

### TEST PROCEDURE

The RF power output was measured with a power meter connected to the RF Antenna connector (conducted measurement) while EUT was operating in transmit mode at the appropriate center frequency, A power meter was used to record the shape of the transmit signal.



**TEST RESULTS****Modulation Type: GFSK, CFG PKT Packet Type: 15 Packet Size: 339 (DH5)**

| <b>Channel</b> | <b>Channel Frequency (MHz)</b> | <b>Peak Power Output (dBm)</b> | <b>Peak Power Limit (dBm)</b> | <b>Pass / Fail</b> |
|----------------|--------------------------------|--------------------------------|-------------------------------|--------------------|
| Low            | 2402                           | 3.10                           | 20.97                         | PASS               |
| Middle         | 2441                           | 3.21                           | 20.97                         | PASS               |
| High           | 2480                           | 3.02                           | 20.97                         | PASS               |

**Remark:** The cable assembly insertion loss of 10.5dB (including 10dB pad and 0.5dB cable) was Entered as an offset in the spectrum analyzer to allow for direct reading of power.



**MAXIMUM PEAK OUTPUT POWER**

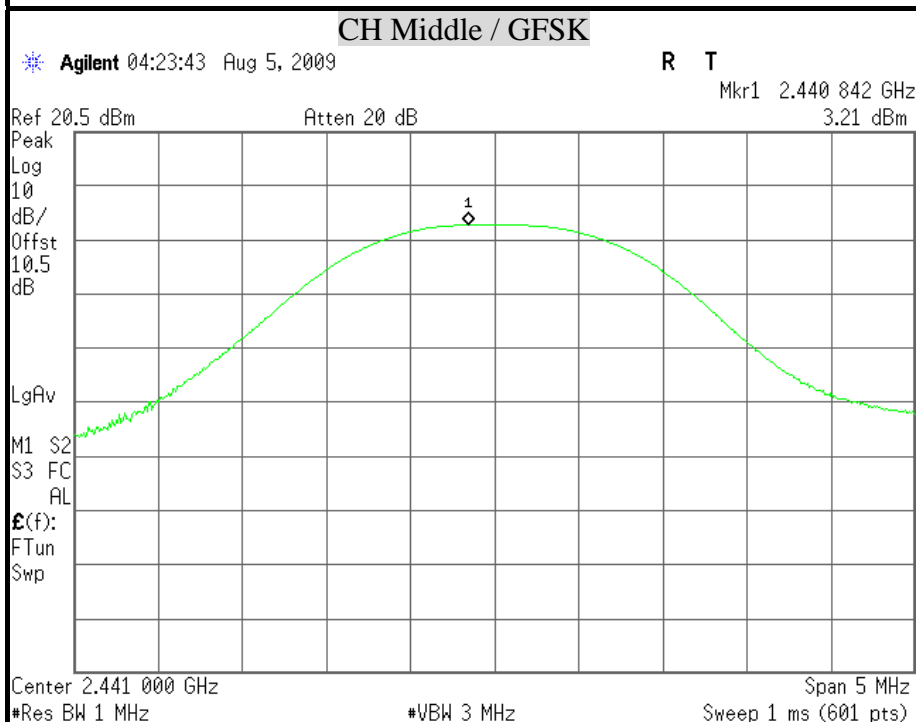
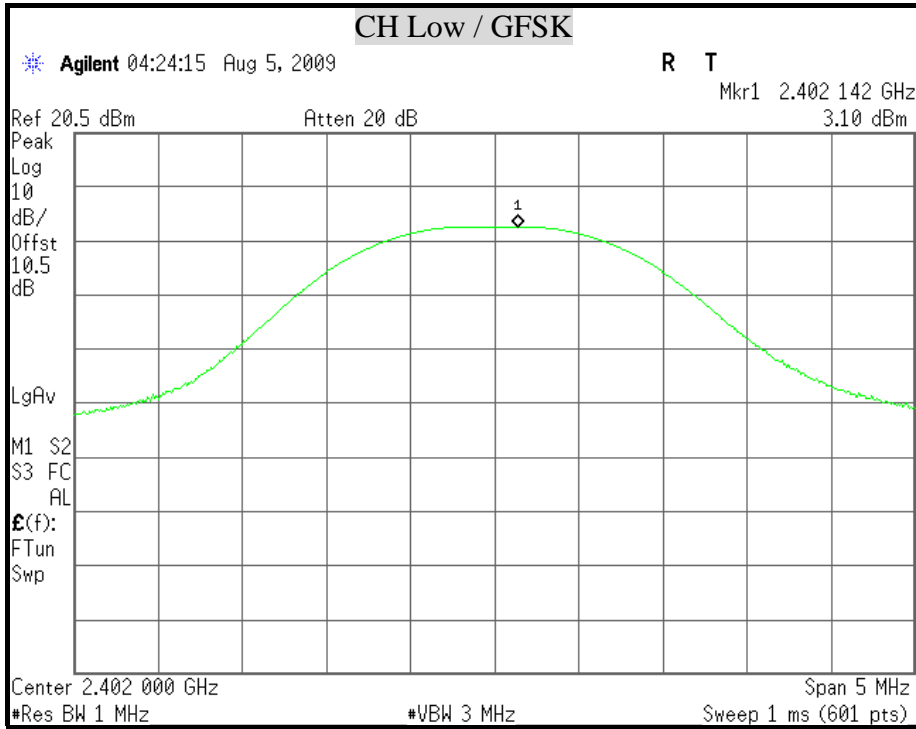

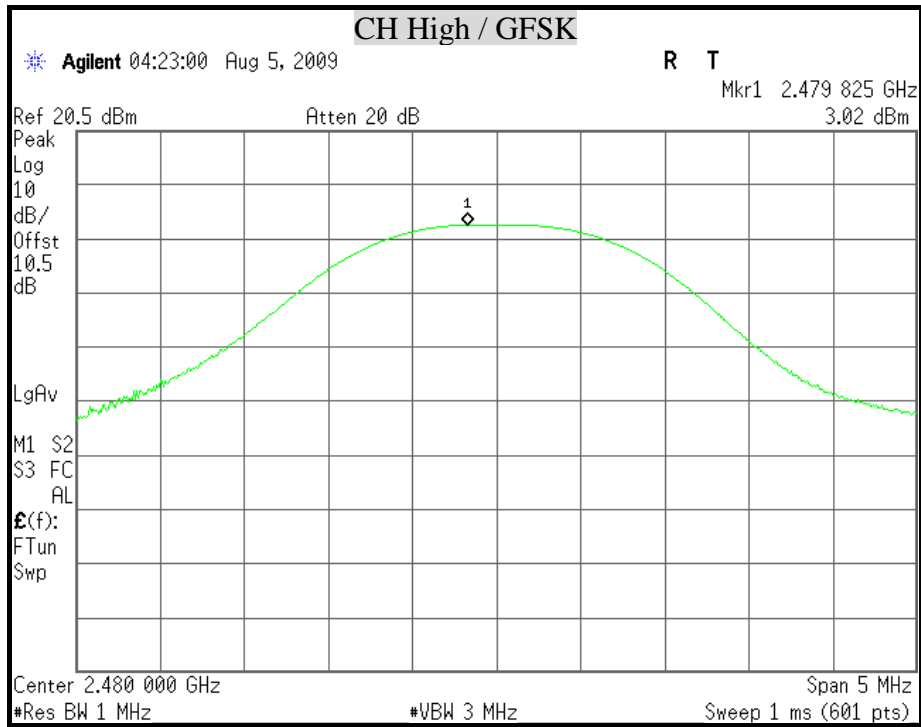



### 8.3 HOPPING CHANNEL SEPARATION

#### LIMIT

§15.247(a)(1) Frequency hopping systems shall have hopping channel carrier frequencies separated by a minimum of 25 kHz or the 20 dB bandwidth of the hopping channel, whichever is greater. Alternatively, frequency hopping systems operating in the 2400-2483.5 MHz band may have hopping channel carrier frequencies that are separated by 25 kHz or two-thirds of the 20 dB bandwidth of the hopping channel, whichever is greater, provided the systems operate with an output power no greater than 125 mW. The system shall hop to channel frequencies that are selected at the system hopping rate from a pseudorandomly ordered list of hopping frequencies. Each frequency must be used equally on the average by each transmitter. The system receivers shall have input bandwidths that match the hopping channel bandwidths of their corresponding transmitters and shall shift frequencies in synchronization with the transmitted signals.

#### TEST EQUIPMENT

| Name of Equipment | Manufacturer | Model  | Serial Number | Calibration Due |
|-------------------|--------------|--------|---------------|-----------------|
| SPECTRUM ANALYZER | AGILENT      | E4446A | MY43360132    | 06/09/2010      |
| SPECTRUM ANALYZER | AGILENT      | E4446A | MY46180323    | 05/26/2010      |

*Remark: Each piece of equipment is scheduled for calibration once a year.*

#### TEST SETUP

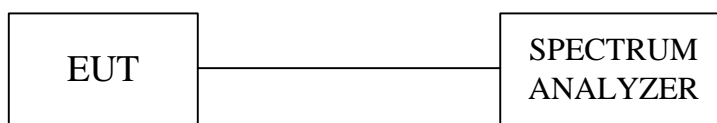

#### TEST PROCEDURE

1. Check the calibration of the measuring instrument using either an internal calibrator or a known signal from an external generator.
2. Position the EUT as shown in test setup without connection to measurement instrument. Turn on the EUT and connect it to measurement instrument. Then set it to any one convenient frequency within its operating range.
3. By using the MaxHold function record the separation of adjacent channels.
4. Measure the frequency difference of these two adjacent channels by spectrum analyzer MARK function. And then plot the result on spectrum analyzer screen.
5. Repeat above procedures until all frequencies measured were complete.

**TEST RESULTS**

Refer to section 8.1, 20dB bandwidth measurement, the measured channel separation should be greater than two-third of 20dB bandwidth or Minimum bandwidth.

**Modulation Type: GFSK, CFG PKT Packet Type: 15 Packet Size: 339 (DH5)**

| <b>Channel</b> | <b>Adjacent Hopping Channel Separation (kHz)</b> | <b>Two –third of 20dB bandwidth (kHz)</b> | <b>Minimum Bandwidth (kHz)</b> | <b>Result</b> |
|----------------|--|---|--------------------------------|---------------|
| 2441MHz (Mid)  | 1000   | 623.33                                    | 25                             | PASS          |



### HOPPING CHANNEL SEPARATION

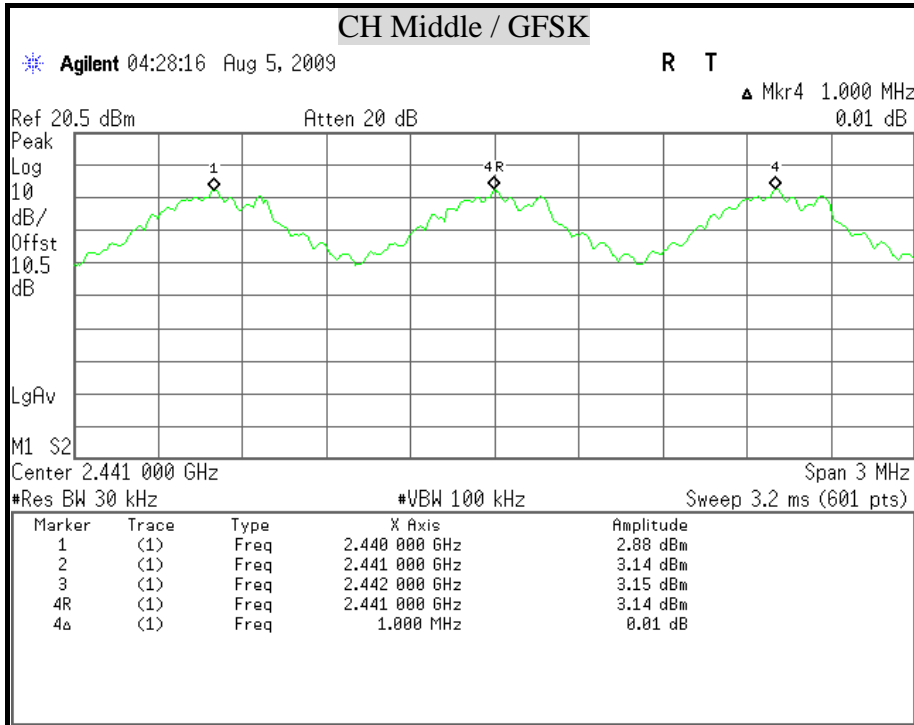



## 8.4 NUMBER OF HOPPING FREQUENCY USED

### LIMIT

§15.247(a)(1)(iii) For frequency hopping systems in the 2400-2483.5 MHz band shall use at least 15 channels.

### TEST EQUIPMENT

| Name of Equipment | Manufacturer | Model  | Serial Number | Calibration Due |
|-------------------|--------------|--------|---------------|-----------------|
| SPECTRUM ANALYZER | AGILENT      | E4446A | MY43360132    | 06/09/2010      |
| SPECTRUM ANALYZER | AGILENT      | E4446A | MY46180323    | 05/26/2010      |

*Remark: Each piece of equipment is scheduled for calibration once a year.*

### TEST SETUP



### TEST PROCEDURE

- 1 Check the calibration of the measuring instrument (spectrum analyzer) using either an internal calibrator or a known signal from an external generator.
- 2 Position the EUT as shown in test setup without connection to measurement instrument. Turn on the EUT and connect its antenna terminal to measurement instrument via a low loss cable. Then set it to any one measured frequency within its operating range and make sure the instrument is operated in its linear range.
- 3 Set the spectrum analyzer on MaxHold Mode, and then keep the EUT in hopping mode. Record all the signals from each channel until each one has been recorded.
- 4 Set the spectrum analyzer on View mode and then plot the result on spectrum analyzer screen.
- 5 Repeat above procedures until all frequencies measured were complete.

### TEST RESULTS

Refer to the attached plot.

There are 79 hopping frequencies in a hopping sequence.



**NUMBER OF HOPPING FREQUENCY USED**

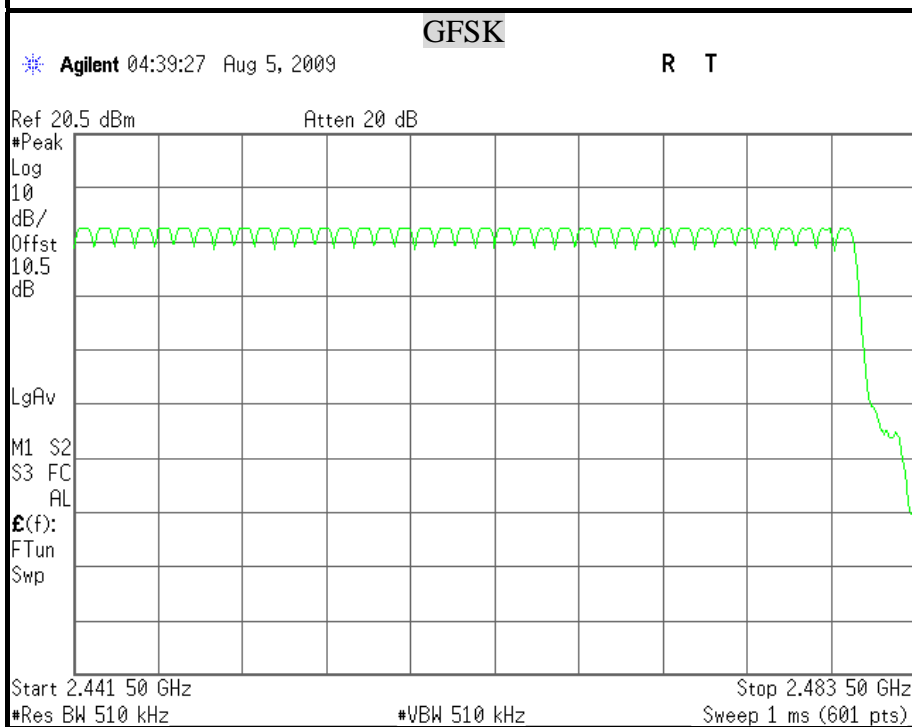
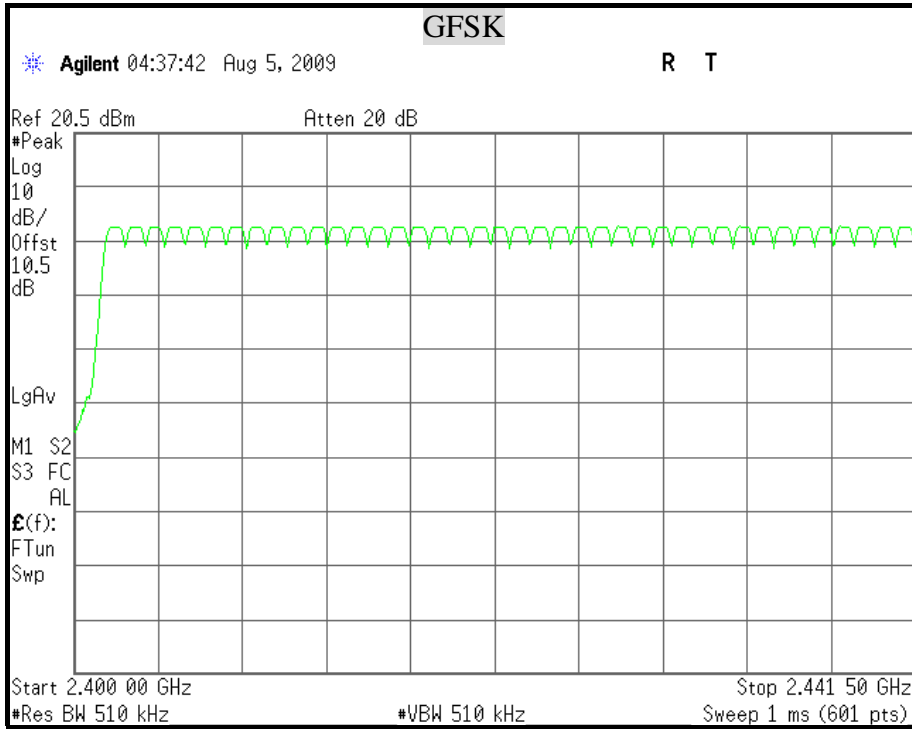





## 8.5 DWELL TIME ON EACH CHANNEL

### LIMIT

§15.247(a)(1)(iii) For frequency hopping system operating in the 2400-2483.5MHz band, the average time of occupancy on any frequency shall not be greater than 0.4 second within a 31.6 second period.

### TEST EQUIPMENT

| Name of Equipment | Manufacturer | Model  | Serial Number | Calibration Due |
|-------------------|--------------|--------|---------------|-----------------|
| SPECTRUM ANALYZER | AGILENT      | E4446A | MY43360132    | 06/09/2010      |
| SPECTRUM ANALYZER | AGILENT      | E4446A | MY46180323    | 05/26/2010      |

*Remark: Each piece of equipment is scheduled for calibration once a year.*

### TEST SETUP

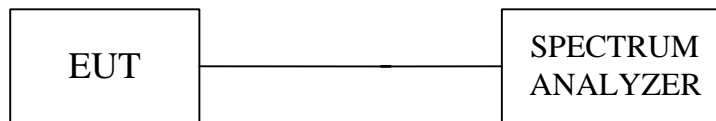

### TEST PROCEDURE

1. Check the calibration of the measuring instrument using either an internal calibrator or a known signal from an external generator.
2. Position the EUT as shown in test setup without connection to measurement instrument. Turn on the EUT and connect its antenna terminal to measurement instrument via a low loss cable. Then set it to any one measured frequency within its operating range and make sure the instrument is operated in its linear range.
3. Adjust the center frequency of spectrum analyzer on any frequency be measured and set spectrum analyzer to zero span mode. And then, set RBW and VBW of spectrum analyzer to proper value.
4. Measure the time duration of one transmission on the measured frequency. And then plot the result with time difference of this time duration.
5. Repeat above procedures until all frequencies measured were complete.
6. The Universal Bluetooth Headset has 3 type of payload, DH1, DH3, DH5. The hopping rate is 1600 per second.

The longer the payload is, the slower the hopping rate is.

**TEST RESULTS**

Time of occupancy on the TX channel in 31.6sec = time domain slot length × hop rate ÷ number of hop per channel × 31.6

Refer to the attached graph.

The hopping rates of Bluetooth devices change with different types of payload. The longer the payload is, the slower the hopping rate. The hopping rate scenario is defined in Bluetooth core specification.

**Modulation Type: GFSK, CFG PKT Packet Type: 15 Packet Size: 339 (DH5)**

| Transmitting Frequency | Packet type | Dwell time (ms) | Time of occupancy on the TX channel in 31.6sec (ms) | Limit for Time of occupancy on the TX channel in 31.6sec (ms) | Results |
|------------------------|-------------|-----------------|---|---|---------|
| 2441MHz                | DH1         | 0.400           | 128.00  | 400   | PASS    |
| 2441MHz                | DH3         | 1.650           | 264.00  | 400   | PASS    |
| 2441MHz                | DH5         | 2.900           | 309.33  | 400   | PASS    |

DH1 Dwell time =  $0.400 \text{ ms} \times (1600 \div 2) \div 79 \times 31.6 = 128.00 \text{ (ms)}$

DH3 Dwell time =  $1.650 \text{ ms} \times (1600 \div 4) \div 79 \times 31.6 = 264.00 \text{ (ms)}$

DH5 Dwell time =  $2.900 \text{ ms} \times (1600 \div 6) \div 79 \times 31.6 = 309.33 \text{ (ms)}$



**DWELL TIME ON EACH PAYLOAD**

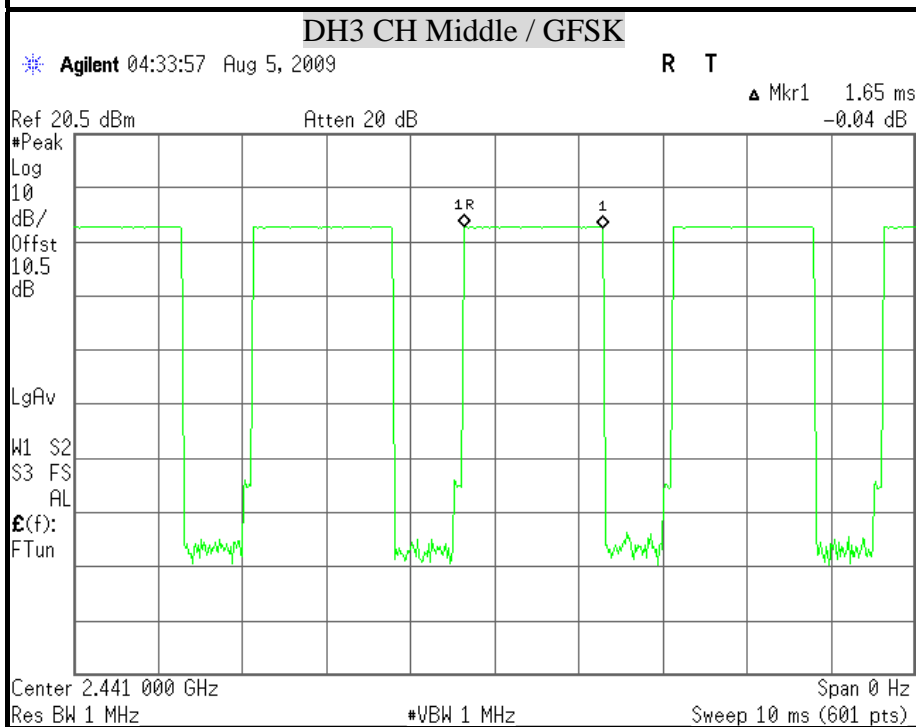
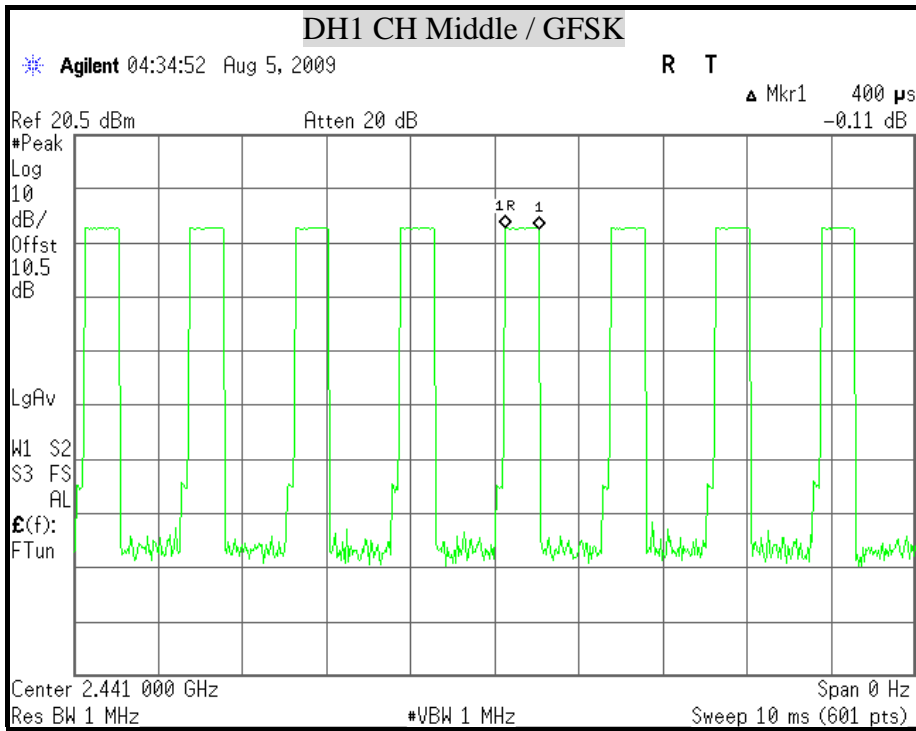

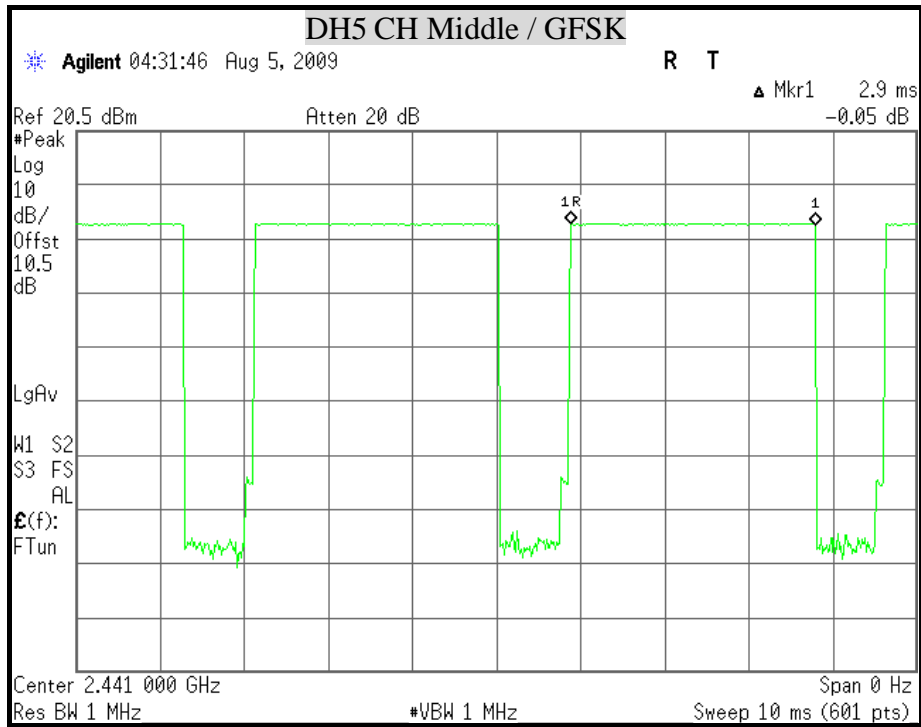



## 8.6 CONDUCTED SPURIOUS EMISSION

### LIMITS

§ 15.247(d) In any 100 kHz bandwidth outside the frequency band in which the spread spectrum intentional radiator is operating, the radio frequency power that is produced by the intentional radiator shall be at least 20 dB below that in the 100 kHz bandwidth within the and that contains the highest level of the desired power, based on either an RF conducted or a radiated measurement. Attenuation below the general limits specified in § 15.209(a) is not required. In addition, radiated emissions which fall in the restricted bands, as defined in § 15.205(a), must also comply with the radiated emission limits specified in § 15.209(a) (see § 15.205(c)).

### TEST EQUIPMENT

| Name of Equipment | Manufacturer | Model  | Serial Number | Calibration Due |
|-------------------|--------------|--------|---------------|-----------------|
| SPECTRUM ANALYZER | AGILENT      | E4446A | MY43360132    | 06/09/2010      |
| SPECTRUM ANALYZER | AGILENT      | E4446A | MY46180323    | 05/26/2010      |

*Remark: Each piece of equipment is scheduled for calibration once a year.*

### TEST SETUP

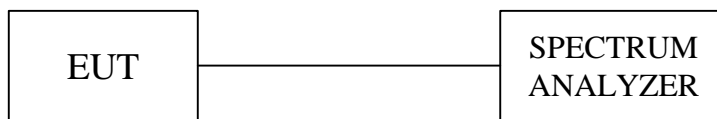

### TEST PROCEDURE

The transmitter output is connected to a spectrum analyzer. The resolution bandwidth is set to 100 kHz. The video bandwidth is set to 100 kHz.

The spectrum from 30 MHz to 26.5 GHz is investigated with the transmitter set to the lowest, middle, and highest channels in the 2.4 GHz band.



**TEST RESULTS**

**BAND EDGE COMPLIANCE OF RF CONDUCTED EMISSIONS**

**OUT-OF-BAND SPURIOUS EMISSIONS-CONDUCTED MEASUREMENT**

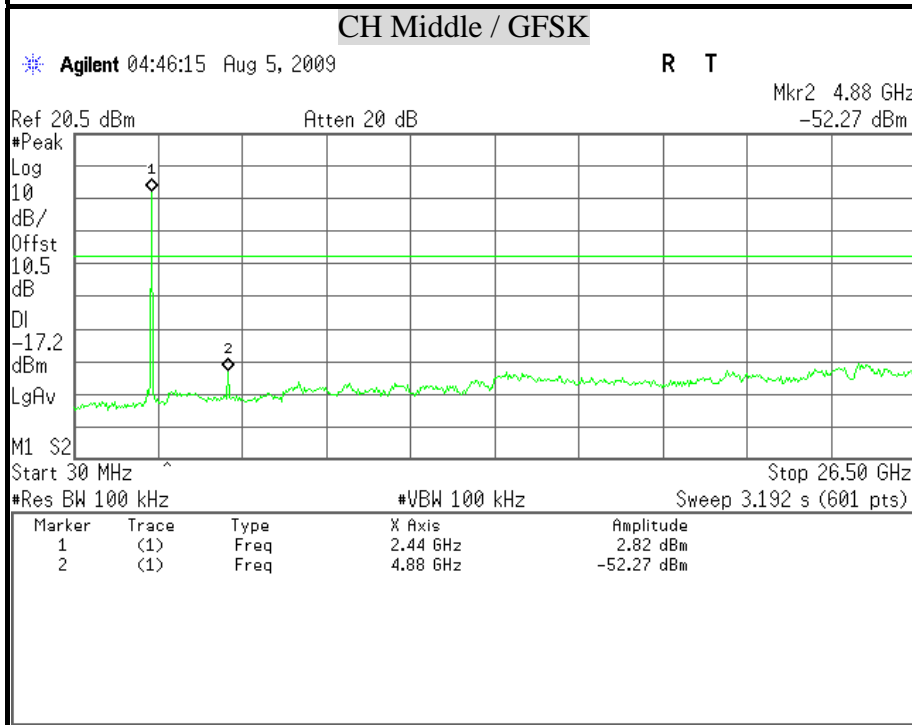
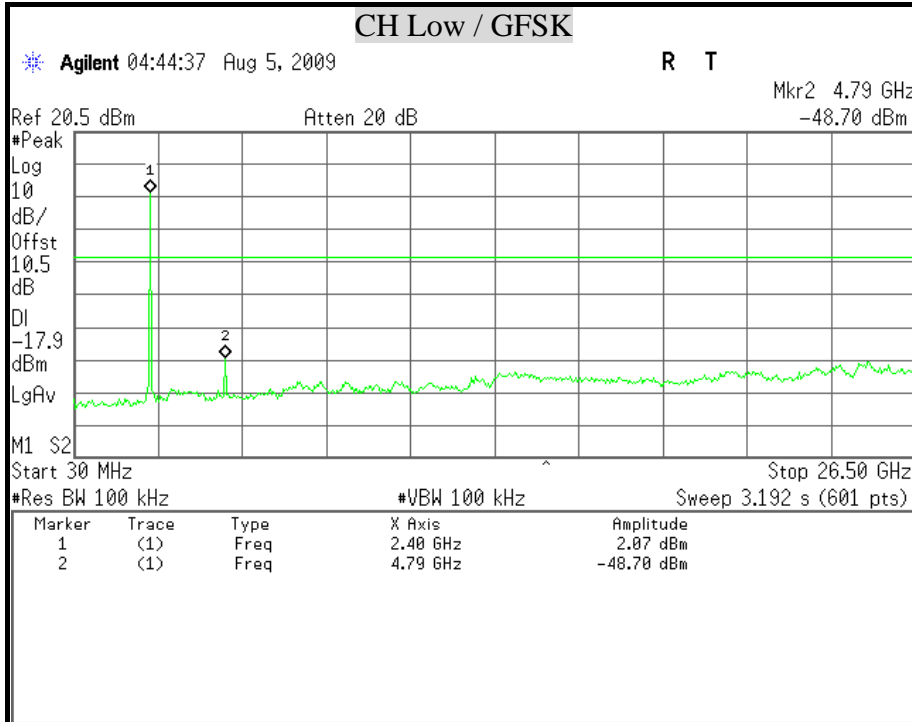

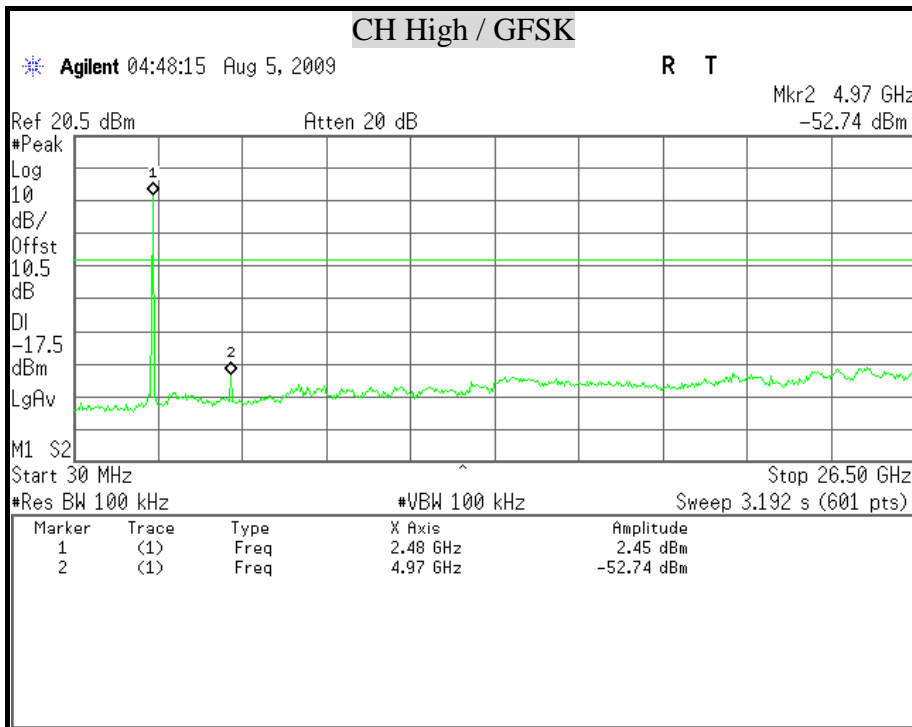



## 8.7 RADIATED EMISSIONS

### 8.7.1 TRANSMITTER RADIATED SUPURIOUS EMSSIONS

#### LIMITS

§ 15.205 (a) Except as shown in paragraph (d) of this section, only spurious emissions are permitted in any of the frequency bands listed below:

| MHz                        | MHz                   | MHz             | GHz              |
|----------------------------|-----------------------|-----------------|------------------|
| 0.090 - 0.110              | 16.42 - 16.423        | 399.9 - 410     | 4.5 - 5.15       |
| <sup>1</sup> 0.495 - 0.505 | 16.69475 - 16.69525   | 608 - 614       | 5.35 - 5.46      |
| 2.1735 - 2.1905            | 16.80425 - 16.80475   | 960 - 1240      | 7.25 - 7.75      |
| 4.125 - 4.128              | 25.5 - 25.67          | 1300 - 1427     | 8.025 - 8.5      |
| 4.17725 - 4.17775          | 37.5 - 38.25          | 1435 - 1626.5   | 9.0 - 9.2        |
| 4.20725 - 4.20775          | 73 - 74.6             | 1645.5 - 1646.5 | 9.3 - 9.5        |
| 6.215 - 6.218              | 74.8 - 75.2           | 1660 - 1710     | 10.6 - 12.7      |
| 6.26775 - 6.26825          | 108 - 121.94          | 1718.8 - 1722.2 | 13.25 - 13.4     |
| 6.31175 - 6.31225          | 123 - 138             | 2200 - 2300     | 14.47 - 14.5     |
| 8.291 - 8.294              | 149.9 - 150.05        | 2310 - 2390     | 15.35 - 16.2     |
| 8.362 - 8.366              | 156.52475 - 156.52525 | 2483.5 - 2500   | 17.7 - 21.4      |
| 8.37625 - 8.38675          | 156.7 - 156.9         | 2655 - 2900     | 22.01 - 23.12    |
| 8.41425 - 8.41475          | 162.0125 - 167.17     | 3260 - 3267     | 23.6 - 24.0      |
| 12.29 - 12.293             | 167.72 - 173.2        | 3332 - 3339     | 31.2 - 31.8      |
| 12.51975 - 12.52025        | 240 - 285             | 3345.8 - 3338   | 36.43 - 36.5     |
| 12.57675 - 12.57725        | 322 - 335.4           | 3600 - 4400     | ( <sup>2</sup> ) |
| 13.36 - 13.41              |                       |                 |                  |

<sup>1</sup> Until February 1, 1999, this restricted band shall be 0.490-0.510 MHz.

<sup>2</sup> Above 38.6

§ 15.205 (b) Except as provided in paragraphs (d) and (e), the field strength of emissions appearing within these frequency bands shall not exceed the limits shown in Section 15.209. At frequencies equal to or less than 1000 MHz, compliance with the limits in Section 15.209 shall be demonstrated using measurement instrumentation employing a CISPR quasi-peak detector. Above 1000 MHz, compliance with the emission limits in Section 15.209 shall be demonstrated based on the average value of the measured emissions. The provisions in Section 15.35 apply to these measurements.





§ 15.209 (a) Except as provided elsewhere in this Subpart, the emissions from an intentional radiator shall not exceed the field strength levels specified in the following table :

| Frequency (MHz) | Field Strength (microvolts/meter) | Measurement Distance (meters) |
|-----------------|-----------------------------------|-------------------------------|
| 30 - 88         | 100 **                            | 3                             |
| 88 - 216        | 150 **                            | 3                             |
| 216 - 960       | 200 **                            | 3                             |
| Above 960       | 500                               | 3                             |

\*\* Except as provided in paragraph (g), fundamental emissions from intentional radiators operating under this Section shall not be located in the frequency bands 54-72 MHz, 76-88 MHz, 174-216 MHz or 470-806 MHz, However, operation within these frequency bands is permitted under other sections of this Part, e-g, Sections 15.231 and 15.241.

§ 15.209 (b) In the emission table above, the tighter limit applies at the band edges.

### TEST EQUIPMENT

| Name of Equipment            | Manufacturer  | Model           | Serial Number | Calibration Due |
|------------------------------|---------------|-----------------|---------------|-----------------|
| SPECTRUM ANALYZER            | AGILENT       | E4446A          | MY43360132    | 06/09/2010      |
| EMI TEST RECEIVER            | R & S         | ESCI            | 100221        | 05/17/2010      |
| BILOG ANTENNA                | SCHWARZBECK   | VULB            | 9168_249      | 09/17/2009      |
| Double-Ridged Waveguide Horn | ETS LINDGREN  | 3117            | 00078732      | 06/30/2010      |
| PRE-AMPLIFIER                | EM            | EM30265         | 07032611      | 07/14/2010      |
| Notch Filters Band Reject    | Micro-Tronics | BRM50702-01     | 009           | N.C.R.          |
| RF COAXIAL CABLE             | HUBERSUHNER   | SUCOFLEX 104PEA | SN31350       | 07/21/2010      |
| LOOP ANTENNA                 | EMCO          | 6502            | 2356          | 05/28/2010      |

**Remark:** 1. Each piece of equipment is scheduled for calibration once a year.

2. N.C.R = No Calibration Request.

## TEST SETUP

The diagram below shows the test setup that is utilized to make the measurements for emission from below 1GHz.

### 9kHz ~ 30MHz

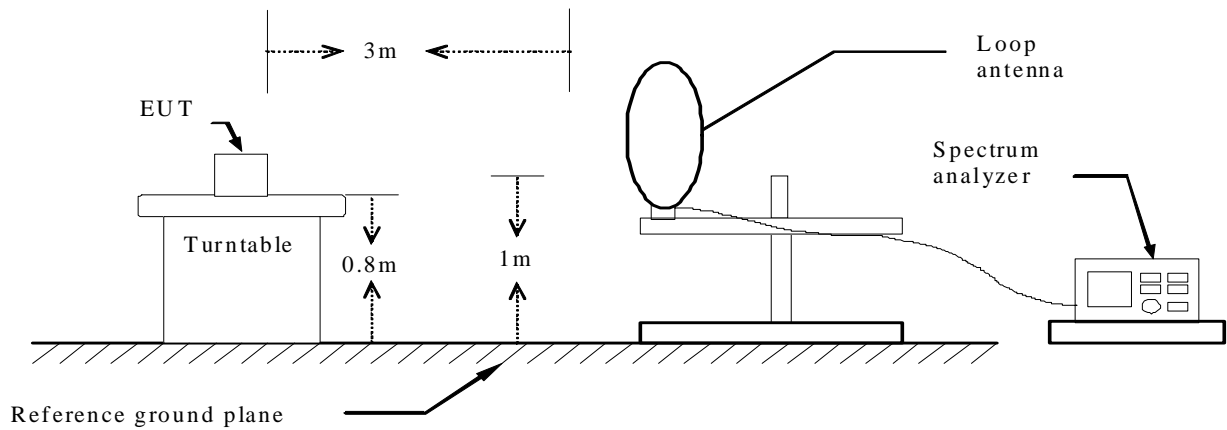

### 30MHz ~ 1GHz

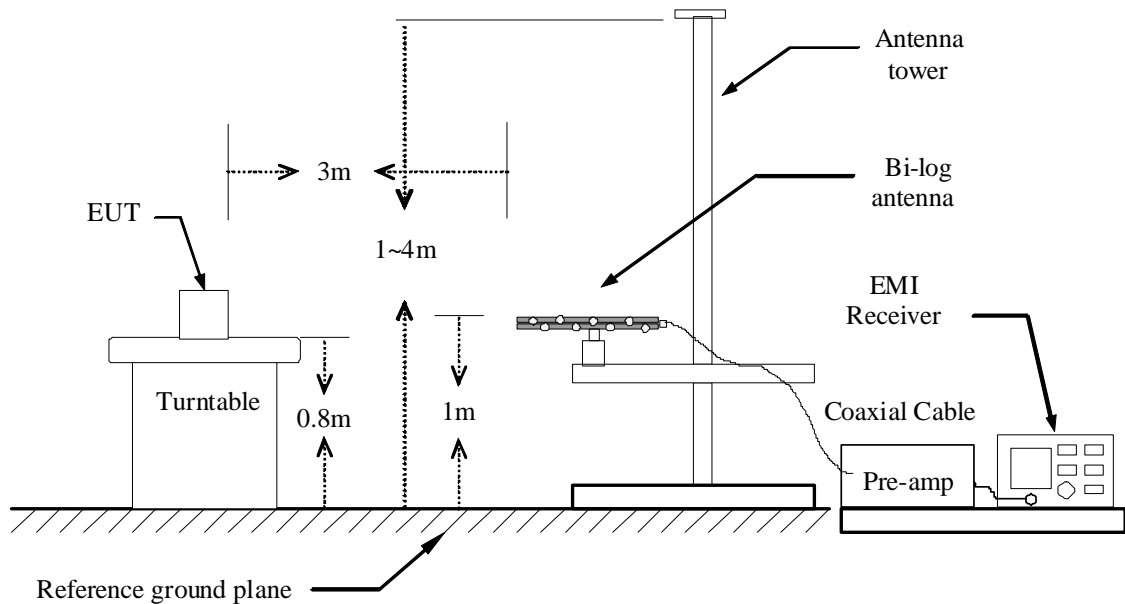

The diagram below shows the test setup that is utilized to make the measurements for emission above 1GHz.

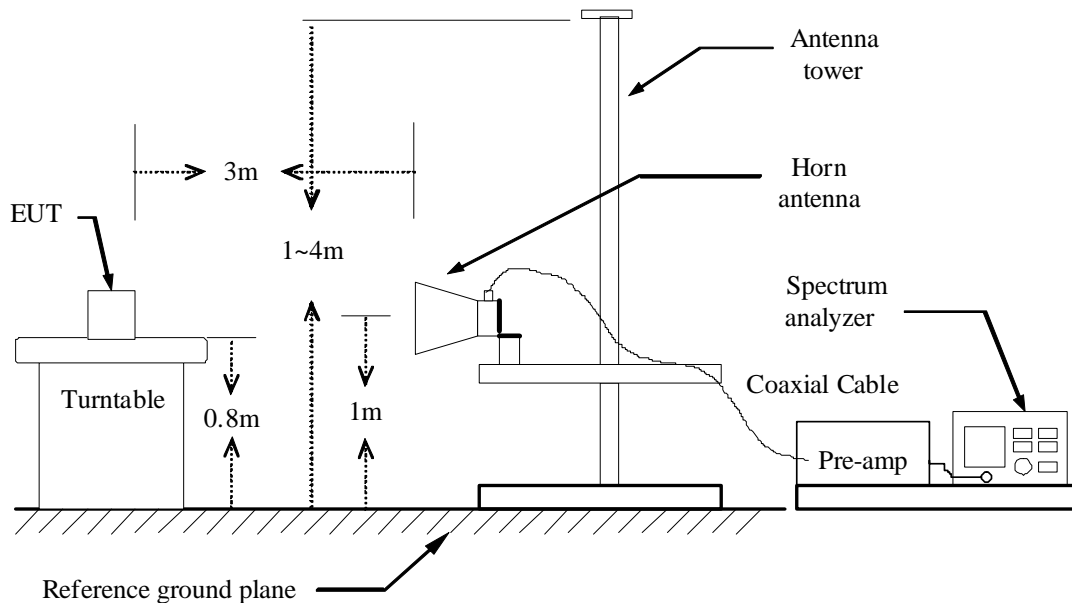

## **TEST PROCEDURE**

- The EUT was placed on the top of a rotating table 0.8 meters above the ground at a 10 meter open area test site. The table was rotated 360 degrees to determine the position of the highest radiation.
- When measuring the radiated emission below 1GHz, the EUT was set 3 meters away from the interference-receiving antenna, which was mounted on the top of a variable-height antenna tower. When measuring the radiated emission above 1GHz, the EUT was set 3 meters away from the interference-receiving antenna.
- The antenna is a broadband antenna, and its height is varied from one meter to four meters above the ground to determine the maximum value of the field strength. Both horizontal and vertical polarization of the antenna are set to make the measurement.
- For each suspected emission, the EUT was arranged to its worst case and then the antenna was tuned to heights from 1 meter to 4 meters and the table was turned from 0 degrees to 360 degrees to find the maximum reading.
- The test-receiver system was set to Peak Detect Function and Specified Bandwidth with Maximum Hold Mode.
- If the emission level of the EUT in peak mode was 10 dB lower than the limit specified, then testing could be stopped and the peak values of the EUT would be reported. Otherwise the emissions that did not have 10 dB margin would be re-tested one by one using peak, quasi-peak or average method as specified and then reported in a data sheet.

Note :

- The resolution bandwidth and video bandwidth of test receiver/spectrum analyzer is 120 KHz for Peak detection (PK) and Quasi-peak detection (QP) at frequency below 1GHz.
- The resolution bandwidth and video bandwidth of test receiver/spectrum analyzer is 1 MHz for Peak detection and frequency above 1GHz.
- The resolution bandwidth of test receiver/spectrum analyzer is 1 MHz and the video bandwidth is 10 Hz for Average detection (AV) at frequency above 1GHz.

**8.7.2 WORST-CASE RADIATED EMISSION BELOW 1 GHz****BELOW 1 GHz (9kHz ~ 30MHz)**

No emission found between lowest internal used/generated frequency to 30MHz.

**BELOW 1 GHz (30MHz ~ 1GHz)**

|                     |                            |                            |              |
|---------------------|----------------------------|----------------------------|--------------|
| <b>Product Name</b> | Vodafone Bluetooth Headset | <b>Test Date</b>           | 2009/08/03   |
| <b>Model Name</b>   | VF-BTHS-FLK-001            | <b>Test By</b>             | Rick Lin     |
| <b>Test Mode</b>    | Normal operating           | <b>TEMP &amp; Humidity</b> | 25.3 °C, 52% |

| <b>Horizontal</b> |                |                          |                 |                |             |        |
|-------------------|----------------|--------------------------|-----------------|----------------|-------------|--------|
| Frequency (MHz)   | Reading (dBμV) | Correction Factor (dB/m) | Result (dBμV/m) | Limit (dBμV/m) | Margin (dB) | Remark |
| 41.64             | 52.24          | -30.11                   | 22.13           | 40.00          | -17.87      | Peak   |
| 131.85            | 53.74          | -33.09                   | 20.65           | 43.50          | -22.85      | Peak   |
| 144.46            | 51.20          | -32.02                   | 19.18           | 43.50          | -24.32      | Peak   |
| 167.74            | 50.56          | -31.90                   | 18.67           | 43.50          | -24.83      | Peak   |
| 227.88            | 52.82          | -33.28                   | 19.54           | 46.00          | -26.46      | Peak   |
| 466.50            | 50.75          | -26.37                   | 24.38           | 46.00          | -21.62      | Peak   |
| <b>Vertical</b>   |                |                          |                 |                |             |        |
| Frequency (MHz)   | Reading (dBμV) | Correction Factor (dB/m) | Result (dBμV/m) | Limit (dBμV/m) | Margin (dB) | Remark |
| 32.91             | 55.86          | -31.08                   | 24.79           | 40.00          | -15.21      | Peak   |
| 41.64             | 56.33          | -30.11                   | 26.22           | 40.00          | -13.78      | Peak   |
| 131.85            | 54.72          | -33.09                   | 21.63           | 43.50          | -21.87      | Peak   |
| 144.46            | 53.45          | -32.02                   | 21.43           | 43.50          | -22.07      | Peak   |
| 232.73            | 53.21          | -32.81                   | 20.40           | 46.00          | -25.60      | Peak   |
| 415.09            | 50.25          | -27.23                   | 23.02           | 46.00          | -22.98      | Peak   |

**Remark:**

1. Quasi-peak test would be performed if the peak result were greater than the quasi-peak limit.
2. Data of measurement within this frequency range shown " --- " in the table above means the reading of emissions are attenuated more than 20dB below the permissible limits or the field strength is too small to be measured.
3. Correction Factor (dB/m) = Antenna Factor (dB/m) + Cable Loss (dB) – PreAmp.Gain (dB)
4. Result (dBμV/m) = Reading (dBμV) + Correction Factor (dB/m)
5. Margin (dB) = Remark result (dBμV/m) - Quasi-peak limit (dBμV/m).



|                     |                            |                            |             |
|---------------------|----------------------------|----------------------------|-------------|
| <b>Product Name</b> | Vodafone Bluetooth Headset | <b>Test Date</b>           | 2009/08/03  |
| <b>Model Name</b>   | VF-BTHS-FLK-001            | <b>Test By</b>             | Rick Lin    |
| <b>Test Mode</b>    | Charge mode                | <b>TEMP &amp; Humidity</b> | 25.3°C, 52% |

| Horizontal      |                |                          |                 |                |             |        |
|-----------------|----------------|--------------------------|-----------------|----------------|-------------|--------|
| Frequency (MHz) | Reading (dBμV) | Correction Factor (dB/m) | Result (dBμV/m) | Limit (dBμV/m) | Margin (dB) | Remark |
| 180.35          | 62.92          | -32.94                   | 29.98           | 43.50          | -13.52      | Peak   |
| 191.99          | 64.54          | -33.54                   | 31.00           | 43.50          | -12.50      | Peak   |
| 300.63          | 71.14          | -29.18                   | 41.96           | 46.00          | -4.04       | !Peak  |
| 400.54          | 65.36          | -27.50                   | 37.86           | 46.00          | -8.14       | Peak   |
| 543.13          | 60.86          | -25.20                   | 35.66           | 46.00          | -10.34      | Peak   |
| 761.38          | 59.52          | -21.33                   | 38.20           | 46.00          | -7.80       | Peak   |
| 905.91          | 55.16          | -19.54                   | 35.62           | 46.00          | -10.38      | Peak   |
| Vertical        |                |                          |                 |                |             |        |
| Frequency (MHz) | Reading (dBμV) | Correction Factor (dB/m) | Result (dBμV/m) | Limit (dBμV/m) | Margin (dB) | Remark |
| 131.85          | 64.14          | -33.09                   | 31.05           | 43.50          | -12.45      | Peak   |
| 232.73          | 65.20          | -32.81                   | 32.39           | 46.00          | -13.61      | Peak   |
| 329.73          | 61.99          | -28.54                   | 33.45           | 46.00          | -12.55      | Peak   |
| 460.68          | 61.58          | -26.45                   | 35.13           | 46.00          | -10.87      | Peak   |
| 497.54          | 61.14          | -25.98                   | 35.16           | 46.00          | -10.84      | Peak   |
| 533.43          | 59.72          | -25.37                   | 34.35           | 46.00          | -11.65      | Peak   |
| 673.11          | 57.75          | -23.03                   | 34.72           | 46.00          | -11.28      | Peak   |
| 892.33          | 58.42          | -19.73                   | 38.70           | 46.00          | -7.30       | Peak   |

**Remark:**

1. Quasi-peak test would be performed if the peak result were greater than the quasi-peak limit.
2. Data of measurement within this frequency range shown " --- " in the table above means the reading of emissions are attenuated more than 20dB below the permissible limits or the field strength is too small to be measured.
3. Correction Factor (dB/m) = Antenna Factor (dB/m) + Cable Loss (dB) – PreAmp.Gain (dB)
4. Result (dBuV/m) = Reading (dBuV) + Correction Factor (dB/m)
5. Margin (dB) = Remark result (dBuV/m) - Quasi-peak limit (dBuV/m).

**8.7.3 TRANSMITTER RADIATED EMISSION ABOVE 1 GHz**

|                     |                            |                            |             |
|---------------------|----------------------------|----------------------------|-------------|
| <b>Product Name</b> | Vodafone Bluetooth Headset | <b>Test Date</b>           | 2009/07/30  |
| <b>Model Name</b>   | VF-BTHS-FLK-001            | <b>Test By</b>             | Rick Lin    |
| <b>Test Mode</b>    | CH Low TX / GFSK           | <b>TEMP &amp; Humidity</b> | 25.6°C, 61% |

| Horizontal      |                   |                   |                          |                    |                    |                   |                   |             |         |
|-----------------|-------------------|-------------------|--------------------------|--------------------|--------------------|-------------------|-------------------|-------------|---------|
| Frequency (MHz) | Reading-PK (dBμV) | Reading-AV (dBμV) | Correction Factor (dB/m) | Result-PK (dBμV/m) | Result-AV (dBμV/m) | Limit-PK (dBμV/m) | Limit-AV (dBμV/m) | Margin (dB) | Remark  |
| 2402.00         | 102.67            | ---               | -8.87                    | 93.80              | ---                | ---               | ---               | ---         | Carrier |
| 2500.00         | 64.61             | 57.38             | -8.74                    | 55.88              | 48.64              | 74.00             | 54.00             | -5.36       | AVG     |
| 4807.50         | 67.28             | 56.01             | -4.05                    | 63.23              | 51.96              | 74.00             | 54.00             | -2.04       | AVG     |
| 7020.00         | 48.27             | ---               | 1.79                     | 50.05              | ---                | 74.00             | 54.00             | -3.95       | Peak    |
| 9607.50         | 54.79             | 44.49             | 4.62                     | 59.41              | 49.11              | 74.00             | 54.00             | -4.89       | AVG     |
| Vertical        |                   |                   |                          |                    |                    |                   |                   |             |         |
| Frequency (MHz) | Reading-PK (dBμV) | Reading-AV (dBμV) | Correction Factor (dB/m) | Result-PK (dBμV/m) | Result-AV (dBμV/m) | Limit-PK (dBμV/m) | Limit-AV (dBμV/m) | Margin (dB) | Remark  |
| 1596.00         | 65.64             | ---               | -13.27                   | 52.38              | ---                | 74.00             | 54.00             | -1.62       | Peak    |
| 2402.00         | 100.35            | ---               | -8.87                    | 91.48              | ---                | ---               | ---               | ---         | Carrier |
| 2498.00         | 65.35             | 59.23             | -8.74                    | 56.61              | -50.49             | 74.00             | 54.00             | -3.51       | AVG     |
| 4807.50         | 65.55             | 54.49             | -4.05                    | 61.50              | 50.44              | 74.00             | 54.00             | -3.56       | AVG     |
| 6555.00         | 48.63             | ---               | 0.58                     | 49.20              | ---                | 74.00             | 54.00             | -4.80       | Peak    |
| 9607.50         | 54.59             | 46.63             | 4.62                     | 59.21              | 51.25              | 74.00             | 54.00             | -2.75       | AVG     |

**Remark:**

1. Measuring frequencies from 1 GHz to the 10th harmonic of highest fundamental frequency.
2. Average test would be performed if the peak result were greater than the average limit.
3. Data of measurement within this frequency range shown " --- " in the table above means the reading of emissions are attenuated more than 20dB below the permissible limits or the field strength is too small to be measured.
4. Measurements above show only up to 6 maximum emissions noted, or would be lesser, with " N/A " remark, if no specific emissions from the EUT are recorded (ie: margin>20dB from the applicable limit) and considered that's already beyond the background noise floor.
5. In any 100 kHz bandwidth outside the frequency band in which the spread spectrum or digitally modulated intentional radiator is operating, the radio frequency power that is produced by the intentional radiator shall be at least 20 dB below that in the 100 kHz bandwidth within the band that contains the highest level of the desired power, based on either an RF conducted or a radiated measurement, provided the transmitter demonstrates compliance with the peak conducted power limits. If the transmitter complies with the conducted power limits based on the use of RMS averaging over a time interval, as permitted under paragraph (b)(3) of this section, the attenuation required under this paragraph shall be 30 dB instead of 20 dB.
6. Result = Reading + Correction Factor  
Margin = Result - Limit  
Remark Peak = Result(PK) - Limit(AV)  
Remark AVG = Result(AV) - Limit(AV)



|                     |                            |                            |             |
|---------------------|----------------------------|----------------------------|-------------|
| <b>Product Name</b> | Vodafone Bluetooth Headset | <b>Test Date</b>           | 2009/07/30  |
| <b>Model Name</b>   | VF-BTHS-FLK-001            | <b>Test By</b>             | Rick Lin    |
| <b>Test Mode</b>    | CH Middle TX / GFSK        | <b>TEMP &amp; Humidity</b> | 25.6°C, 61% |

| Horizontal      |                   |                   |                          |                    |                    |                   |                   |             |         |
|-----------------|-------------------|-------------------|--------------------------|--------------------|--------------------|-------------------|-------------------|-------------|---------|
| Frequency (MHz) | Reading-PK (dBμV) | Reading-AV (dBμV) | Correction Factor (dB/m) | Result-PK (dBμV/m) | Result-AV (dBμV/m) | Limit-PK (dBμV/m) | Limit-AV (dBμV/m) | Margin (dB) | Remark  |
| 2442.00         | 97.47             | ---               | -8.81                    | 88.66              | ---                | ---               | ---               | ---         | Carrier |
| 2494.00         | 64.00             | 58.11             | -8.74                    | 55.25              | -49.37             | 74.00             | 54.00             | -4.63       | AVG     |
| 4882.50         | 64.06             | 51.06             | -4.00                    | 60.06              | 47.06              | 74.00             | 54.00             | -6.94       | AVG     |
| 5662.50         | 51.33             | ---               | -1.96                    | 49.37              | ---                | 74.00             | 54.00             | -4.63       | Peak    |
| 6832.50         | 48.54             | ---               | 1.33                     | 49.86              | ---                | 74.00             | 54.00             | -4.14       | Peak    |
| Vertical        |                   |                   |                          |                    |                    |                   |                   |             |         |
| Frequency (MHz) | Reading-PK (dBμV) | Reading-AV (dBμV) | Correction Factor (dB/m) | Result-PK (dBμV/m) | Result-AV (dBμV/m) | Limit-PK (dBμV/m) | Limit-AV (dBμV/m) | Margin (dB) | Remark  |
| 1596.00         | 65.73             | ---               | -13.27                   | 52.46              | ---                | 74.00             | 54.00             | -1.54       | Peak    |
| 2442.00         | 97.77             | ---               | -8.81                    | 88.96              | ---                | ---               | ---               | ---         | Carrier |
| 2490.00         | 65.58             | 59.04             | -8.75                    | 56.83              | 50.29              | 74.00             | 54.00             | -3.71       | AVG     |
| 4882.50         | 53.68             | ---               | -4.00                    | 49.68              | ---                | 74.00             | 54.00             | -4.32       | Peak    |
| 7320.00         | 47.47             | ---               | 1.84                     | 49.31              | ---                | 74.00             | 54.00             | -4.69       | Peak    |
| 9765.00         | 52.66             | 41.86             | 4.64                     | 57.30              | 46.50              | 74.00             | 54.00             | -7.50       | AVG     |

**Remark:**

1. Measuring frequencies from 1 GHz to the 10th harmonic of highest fundamental frequency.
2. Average test would be performed if the peak result were greater than the average limit.
3. Data of measurement within this frequency range shown " --- " in the table above means the reading of emissions are attenuated more than 20dB below the permissible limits or the field strength is too small to be measured.
4. Measurements above show only up to 6 maximum emissions noted, or would be lesser, with " N/A " remark, if no specific emissions from the EUT are recorded (ie: margin>20dB from the applicable limit) and considered that's already beyond the background noise floor.
5. In any 100 kHz bandwidth outside the frequency band in which the spread spectrum or digitally modulated intentional radiator is operating, the radio frequency power that is produced by the intentional radiator shall be at least 20 dB below that in the 100 kHz bandwidth within the band that contains the highest level of the desired power, based on either an RF conducted or a radiated measurement, provided the transmitter demonstrates compliance with the peak conducted power limits. If the transmitter complies with the conducted power limits based on the use of RMS averaging over a time interval, as permitted under paragraph (b)(3) of this section, the attenuation required under this paragraph shall be 30 dB instead of 20 dB.
6. Result = Reading + Correction Factor  
Margin = Result - Limit  
Remark Peak = Result(PK) - Limit(AV)  
Remark AVG = Result(AV) - Limit(AV)



|                     |                            |                            |             |
|---------------------|----------------------------|----------------------------|-------------|
| <b>Product Name</b> | Vodafone Bluetooth Headset | <b>Test Date</b>           | 2009/07/30  |
| <b>Model Name</b>   | VF-BTHS-FLK-001            | <b>Test By</b>             | Rick Lin    |
| <b>Test Mode</b>    | CH High TX / GFSK          | <b>TEMP &amp; Humidity</b> | 25.6°C, 61% |

| Horizontal      |                   |                   |                          |                    |                    |                   |                   |             |         |
|-----------------|-------------------|-------------------|--------------------------|--------------------|--------------------|-------------------|-------------------|-------------|---------|
| Frequency (MHz) | Reading-PK (dBμV) | Reading-AV (dBμV) | Correction Factor (dB/m) | Result-PK (dBμV/m) | Result-AV (dBμV/m) | Limit-PK (dBμV/m) | Limit-AV (dBμV/m) | Margin (dB) | Remark  |
| 2480.00         | 97.83             | ---               | -8.76                    | 89.07              | ---                | ---               | ---               | ---         | Carrier |
| 4957.50         | 64.87             | 56.22             | -3.96                    | 60.91              | 52.26              | 74.00             | 54.00             | -1.74       | AVG     |
| 5505.00         | 51.10             | ---               | -2.51                    | 48.59              | ---                | 74.00             | 54.00             | -5.41       | Peak    |
| 5857.50         | 50.01             | ---               | -1.28                    | 48.74              | ---                | 74.00             | 54.00             | -5.26       | Peak    |
| Vertical        |                   |                   |                          |                    |                    |                   |                   |             |         |
| Frequency (MHz) | Reading-PK (dBμV) | Reading-AV (dBμV) | Correction Factor (dB/m) | Result-PK (dBμV/m) | Result-AV (dBμV/m) | Limit-PK (dBμV/m) | Limit-AV (dBμV/m) | Margin (dB) | Remark  |
| 1596.00         | 66.33             | ---               | -13.27                   | 53.07              | ---                | 74.00             | 54.00             | -0.93       | Peak    |
| 2480.00         | 100.30            | ---               | -8.76                    | 91.54              | ---                | ---               | ---               | ---         | Carrier |
| 2494.00         | 65.27             | 58.99             | -8.74                    | 56.52              | 50.25              | 74.00             | 54.00             | -3.75       | AVG     |
| 4957.50         | 62.27             | 54.13             | -3.96                    | 58.31              | 50.17              | 74.00             | 54.00             | -3.83       | AVG     |
| 5677.50         | 50.55             | ---               | -1.91                    | 48.64              | ---                | 74.00             | 54.00             | -5.36       | Peak    |
| 7252.50         | 48.63             | ---               | 1.83                     | 50.46              | ---                | 74.00             | 54.00             | -3.54       | Peak    |

**Remark:**

1. Measuring frequencies from 1 GHz to the 10th harmonic of highest fundamental frequency.
2. Average test would be performed if the peak result were greater than the average limit.
3. Data of measurement within this frequency range shown " --- " in the table above means the reading of emissions are attenuated more than 20dB below the permissible limits or the field strength is too small to be measured.
4. Measurements above show only up to 6 maximum emissions noted, or would be lesser, with " N/A " remark, if no specific emissions from the EUT are recorded (ie: margin>20dB from the applicable limit) and considered that's already beyond the background noise floor.
5. In any 100 kHz bandwidth outside the frequency band in which the spread spectrum or digitally modulated intentional radiator is operating, the radio frequency power that is produced by the intentional radiator shall be at least 20 dB below that in the 100 kHz bandwidth within the band that contains the highest level of the desired power, based on either an RF conducted or a radiated measurement, provided the transmitter demonstrates compliance with the peak conducted power limits. If the transmitter complies with the conducted power limits based on the use of RMS averaging over a time interval, as permitted under paragraph (b)(3) of this section, the attenuation required under this paragraph shall be 30 dB instead of 20 dB.
6. Result = Reading + Correction Factor  
Margin = Result - Limit  
Remark Peak = Result(PK) - Limit(AV)  
Remark AVG = Result(AV) - Limit(AV)





### 8.7.4 RESTRICTED BAND EDGES

Detector mode : Peak

Polarity : Horizontal

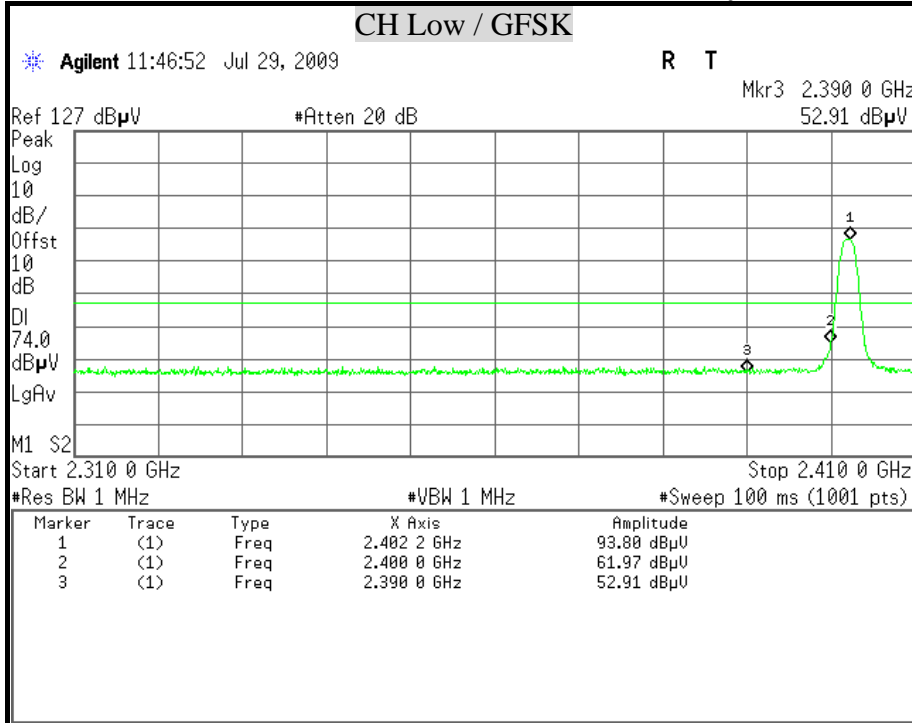

Detector mode : Average

Polarity : Horizontal

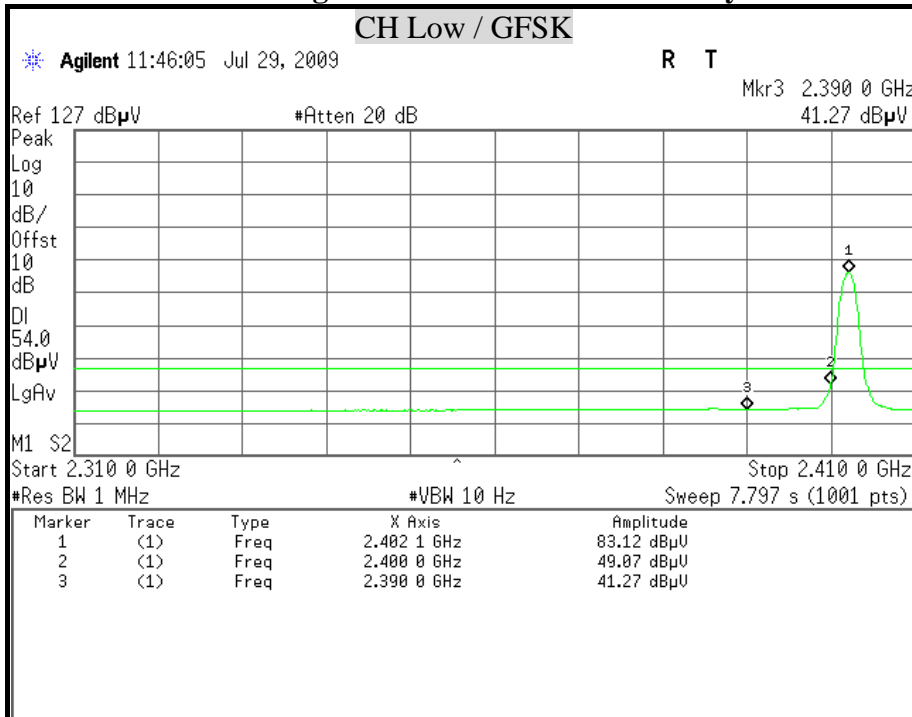



**Detector mode : Peak**

**Polarity : Vertical**

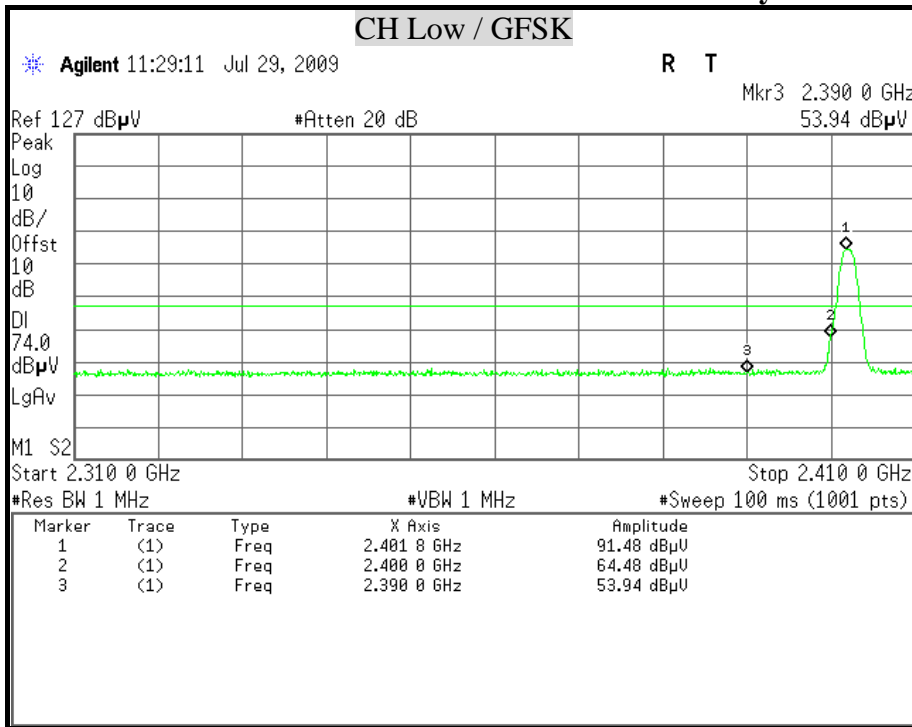

**Detector mode : Average**

**Polarity : Vertical**

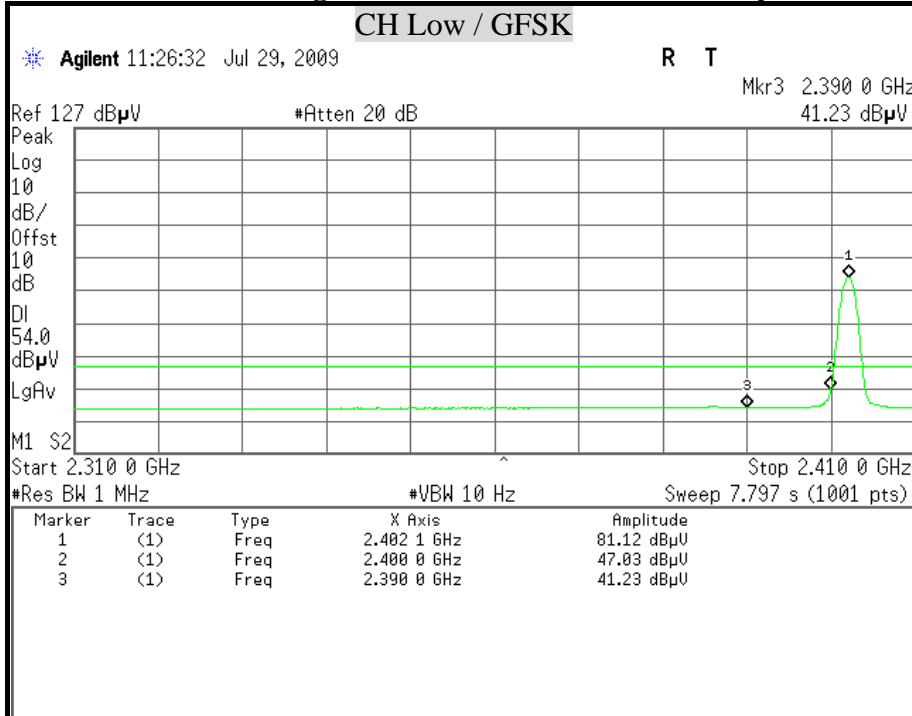



**Detector mode : Peak**

**Polarity : Horizontal**

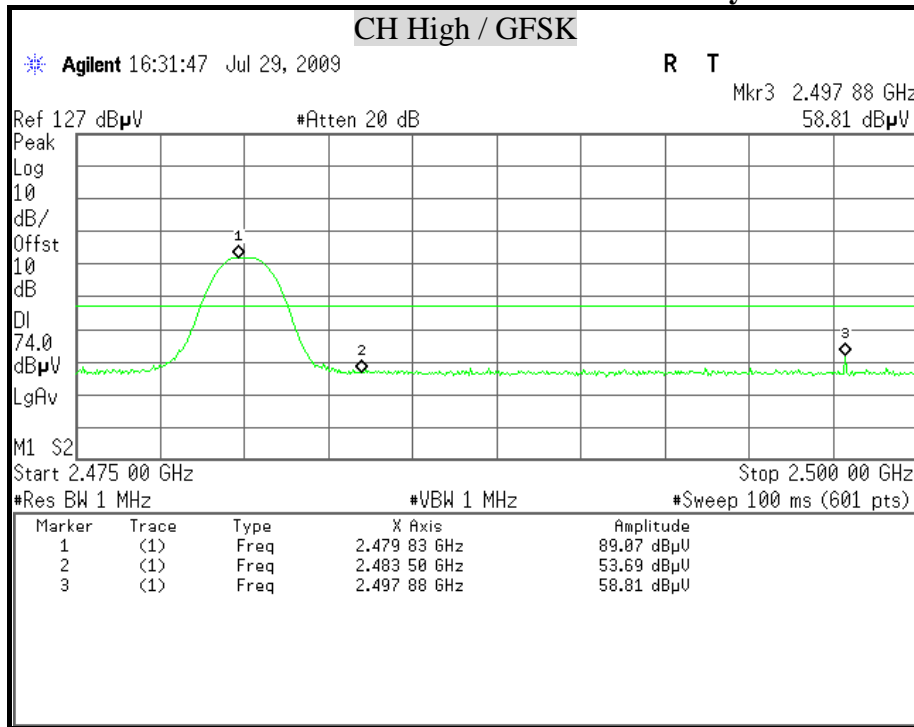

**Detector mode : Average**

**Polarity : Horizontal**

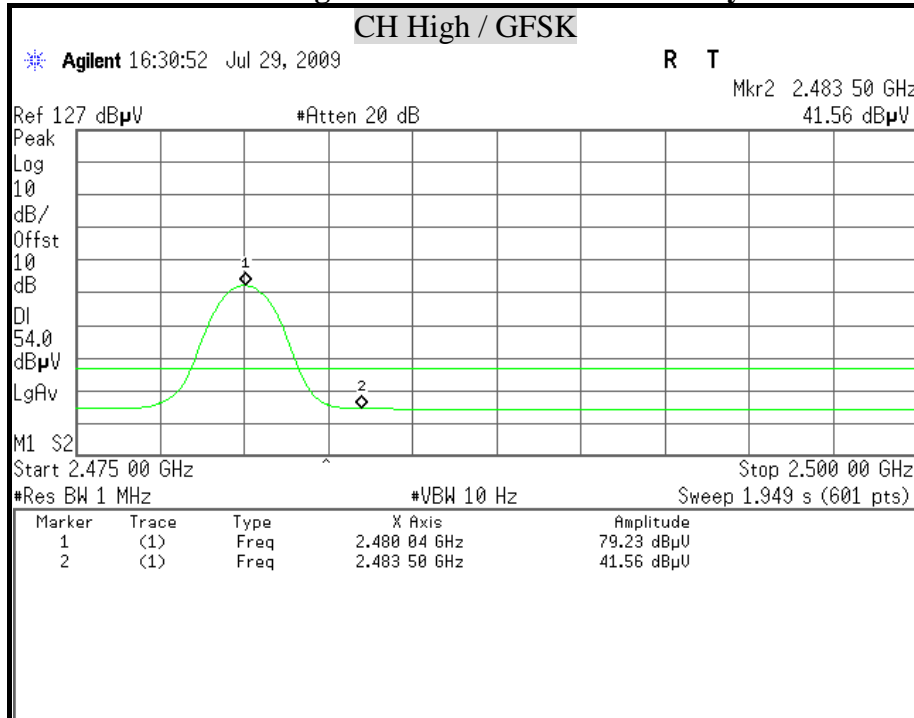



**Detector mode : Peak**

**Polarity : Vertical**

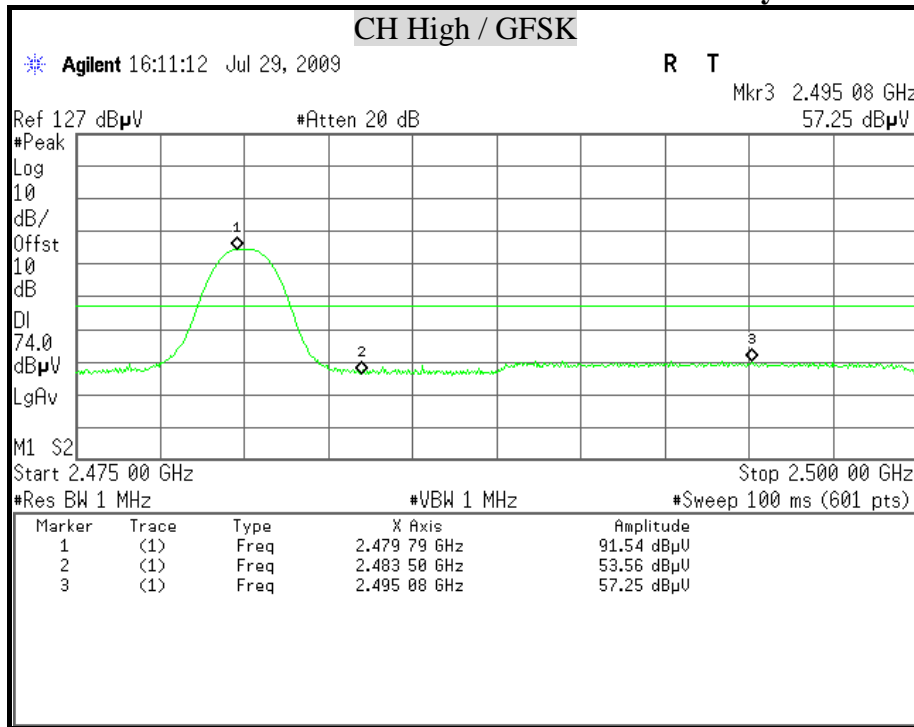

**Detector mode : Average**

**Polarity : Vertical**

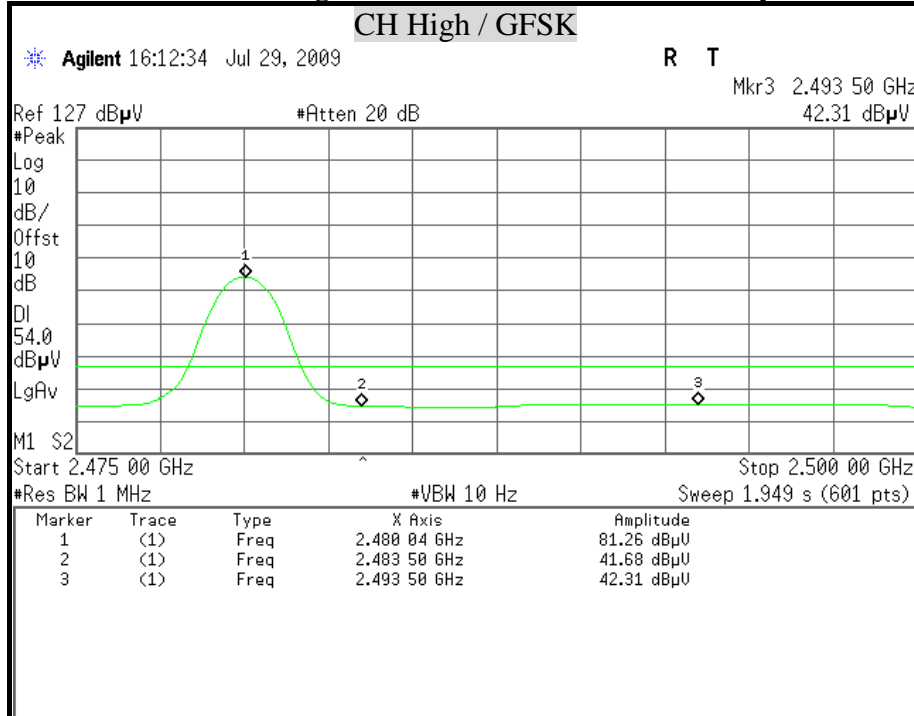



## 8.8 POWERLINE CONDUCTED EMISSIONS

### LIMITS

§ 15.207 (a) Except as shown in paragraph (b) and (c) this section, for an intentional radiator that is designed to be connected to the public utility (AC) power line, the radio frequency voltage that is conducted back onto the AC power line on any frequency or frequencies within the band 150 kHz to 30 MHz shall not exceed the limits in the following table, as measured using a 50  $\mu$ H/50 ohms line impedance stabilization network (LISN). Compliance with the provisions of this paragraph shall be based on the measurement of the radio frequency voltage between each power line and ground at the power terminal.

The lower limit applies at the boundary between the frequency ranges.

| Frequency of Emission (MHz) | Conducted limit (dB $\mu$ v) |          |
|-----------------------------|------------------------------|----------|
|                             | Quasi-peak                   | Average  |
| 0.15 - 0.5                  | 66 to 56                     | 56 to 46 |
| 0.5 - 5                     | 56                           | 46       |
| 5 - 30                      | 60                           | 50       |

### TEST EQUIPMENT

| Name of Equipment    | Manufacturer | Model        | Serial Number | Calibration Due |
|----------------------|--------------|--------------|---------------|-----------------|
| L.I.S.N              | SCHWARZBECK  | NSLK 8127    | 8127-465      | 08/13/2009      |
| L.I.S.N              | SCHWARZBECK  | NSLK 8127    | 8127-473      | 10/12/2009      |
| TEST RECEIVER        | R & S        | ESHS 30      | 838550/003    | 02/02/2010      |
| TEST RECEIVER        | R & S        | ESCS 30      | 826547/004    | 08/05/2010      |
| PULSE LIMIT          | R & S        | ESH3-Z2      | 100117        | 09/23/2009      |
| N TYPE COAXIAL CABLE | BELDEN       | 8268 M17/164 | 003           | 07/09/2010      |

*Remark: Each piece of equipment is scheduled for calibration once a year.*

**TEST SETUP**

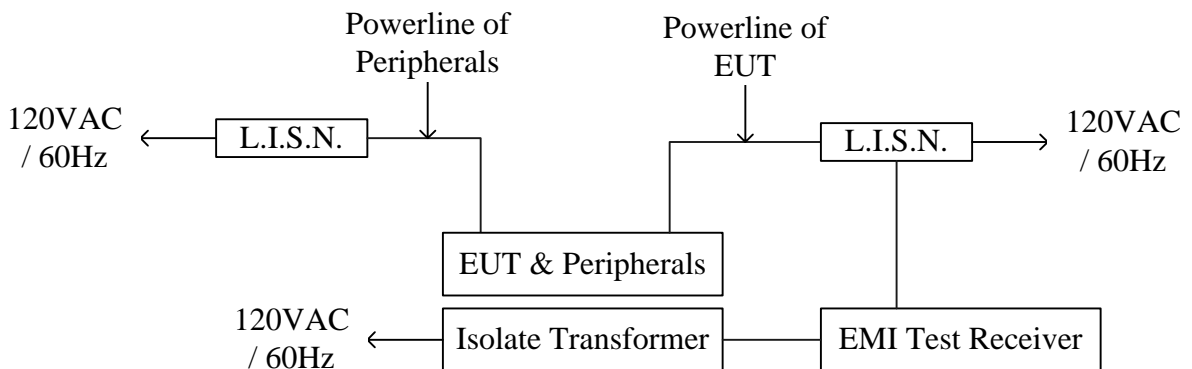
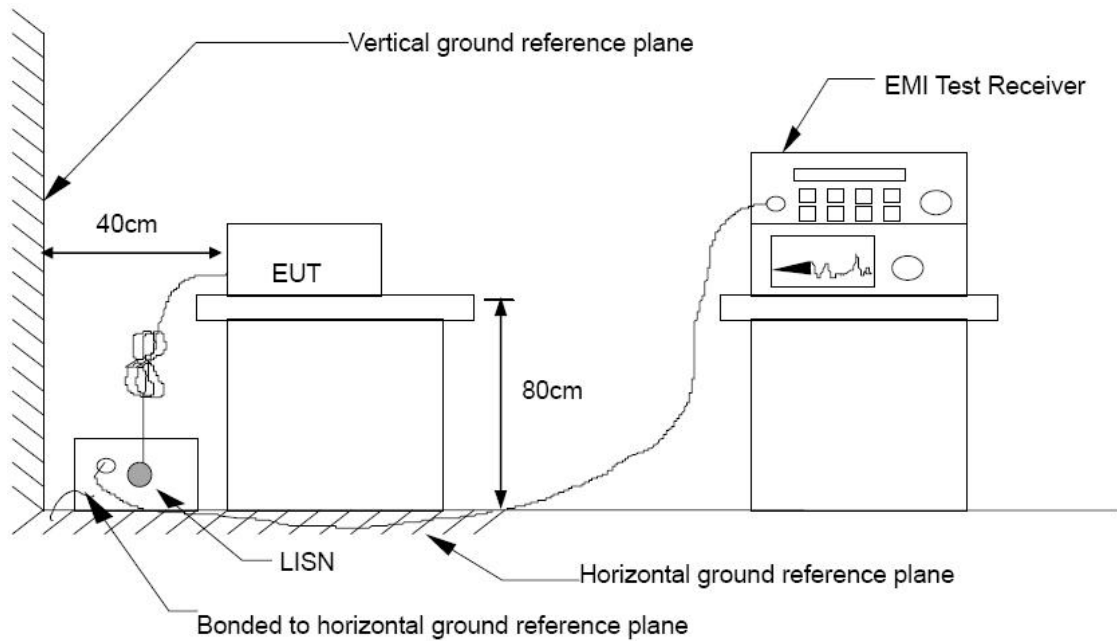

**TEST PROCEDURE**

The EUT is placed on a non-conducting table 40 cm from the vertical ground plane and 80cm above the horizontal ground plane. The EUT IS CONFIGURED IN ACCORDANCE WITH ANSI C63.4 : 2003.

The resolution bandwidth is set to 9 kHz for both quasi-peak detection and average detection measurements.

Line conducted data is recorded for both NEUTRAL and LINE.

**TEST RESULTS**

|                     |                            |                            |             |
|---------------------|----------------------------|----------------------------|-------------|
| <b>Product Name</b> | Vodafone Bluetooth Headset | <b>Test Date</b>           | 2009/08/03  |
| <b>Model</b>        | VF-BTHS-FLK-001            | <b>Test By</b>             | Rueyyan Lin |
| <b>Test Mode</b>    | Charge mode                | <b>TEMP &amp; Humidity</b> | 26.8°C, 59% |

LINE

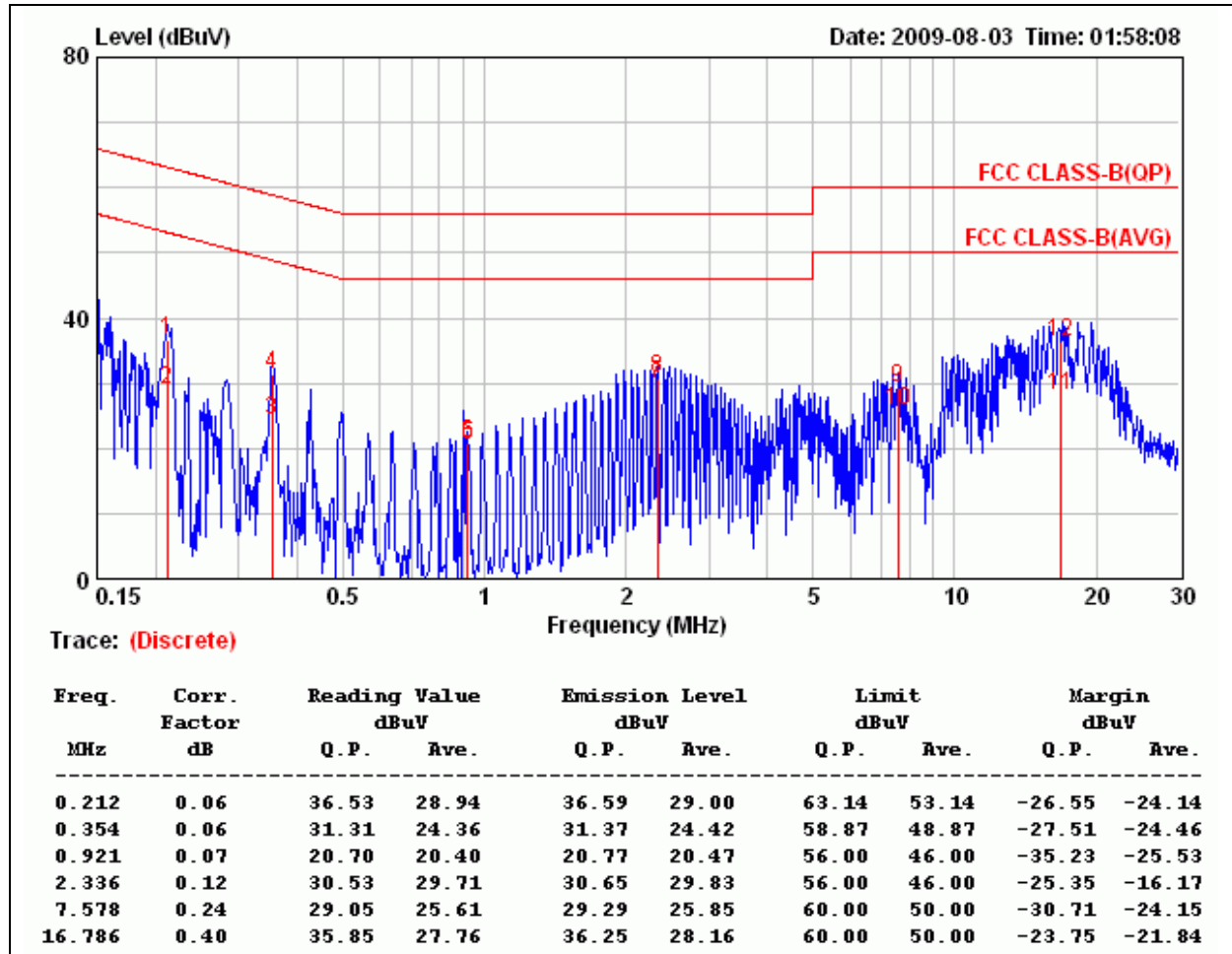
**Remark:**

1. Correction Factor = Insertion loss + cable loss
2. Margin value = Emission level - Limit value



|                     |                            |                            |             |
|---------------------|----------------------------|----------------------------|-------------|
| <b>Product Name</b> | Vodafone Bluetooth Headset | <b>Test Date</b>           | 2009/08/03  |
| <b>Model</b>        | VF-BTHS-FLK-001            | <b>Test By</b>             | Rueyyan Lin |
| <b>Test Mode</b>    | Charge mode                | <b>TEMP &amp; Humidity</b> | 26.8°C, 59% |

NEUTRAL

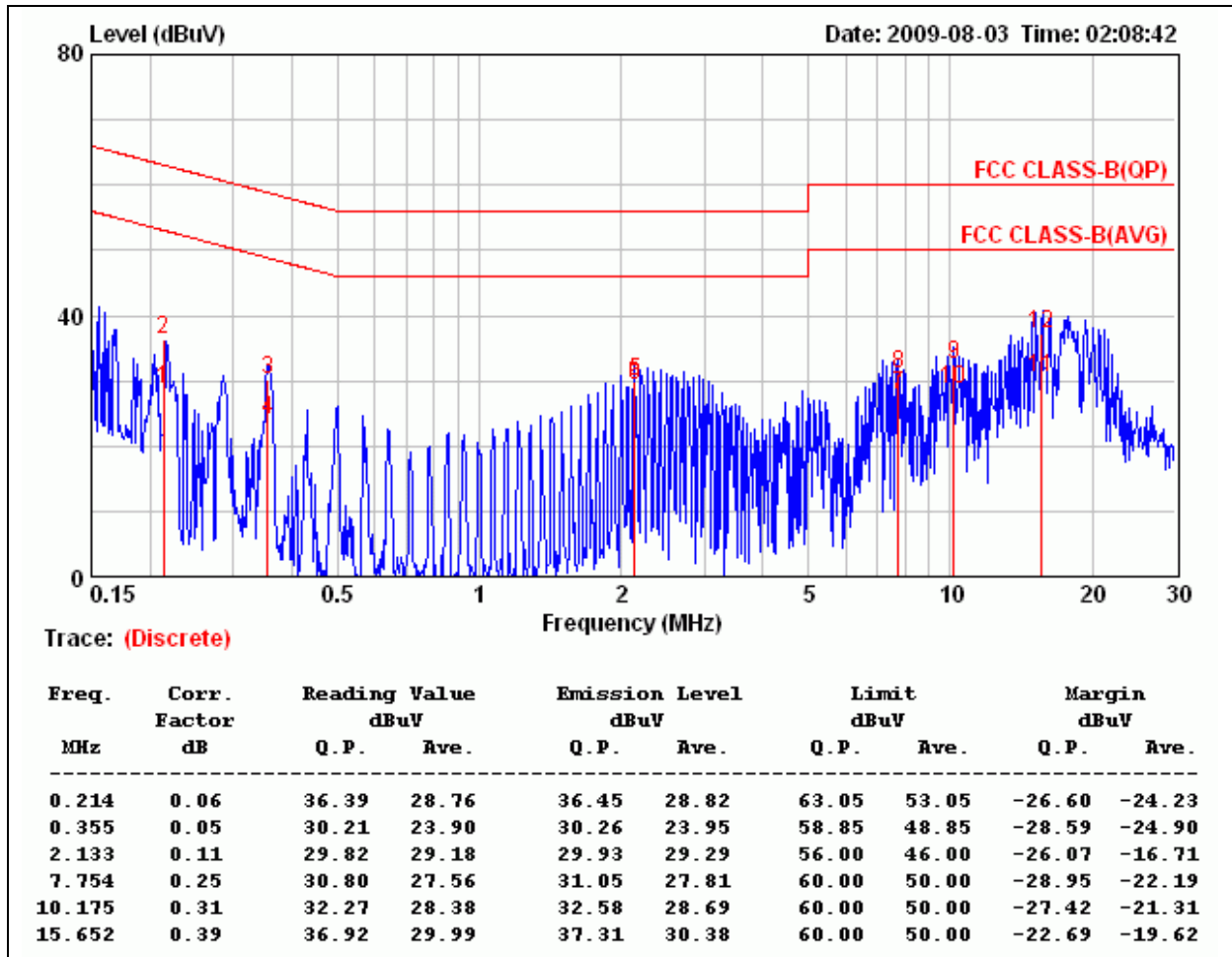

Remark:

1. Correction Factor = Insertion loss + cable loss
2. Margin value = Emission level - Limit value