

H681 Headset V5R5
Antenna Return Loss
& Radiation Pattern Test Plan

Version: 0.1

Project Name: MBT-9126

Test Date: 2007/06/15

Specification:

Tested by: Davis Wu

CONTENT

- 1 TEST SETUP4
 - 1.1 TEST UNIT4
 - 1.2 RETURN LOSS (VSWR) TEST4
 - Test Equipment.....4
 - Test Architecture.....4
 - 1.3 RADIATION PATTERN (GAIN) TEST4
 - Test Equipment.....4
 - Test Lab & Method:.....5
 - Test Architecture.....5
- 2 TEST RESULT AND SUMMARY6
 - 2.1 RETURN LOSS TEST SUMMARY6
 - 2.2 TALKING MODE_RADIATION PATTERN AT 2402,2441,2480 MHz6
 - 2.3 RETURN LOSS AND RADIATION PATTERN RESULTS7
 - Return Loss Result.....7
 - 3D Radiation Pattern @ 2402,2441,2480MHz8

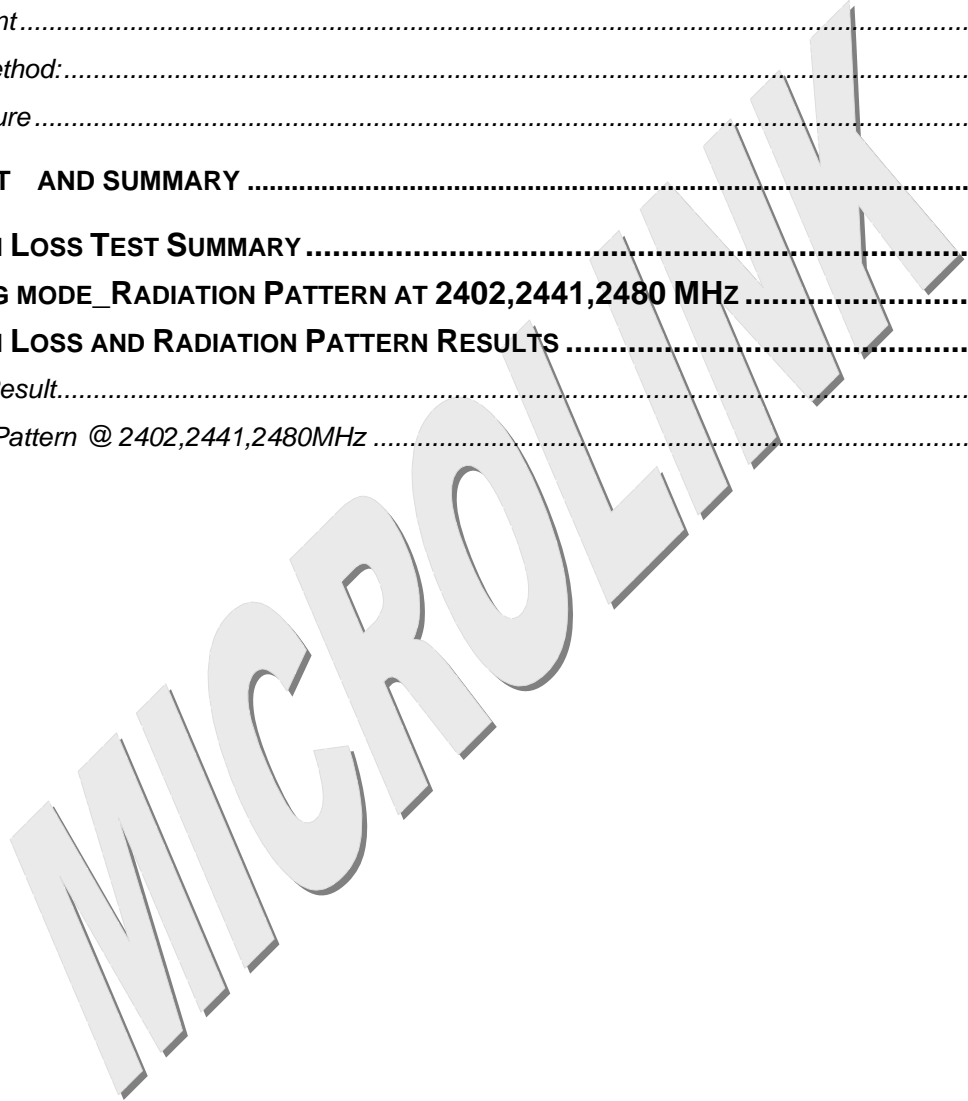

Document History

Rev.	Date	Author	Reason for Changes
0.1	06/015/2007	Davis	<ul style="list-style-type: none">• First Release

MICROLINK

1 TEST SETUP

1.1 Test Unit

1. Hardware Version: V5R5(RTC)
2. Housing: NCVM (black, silver and espresso)

1.2 Return Loss (VSWR) Test

Test Equipment

1. Vector Network Analyzer, Anritsu

Test Architecture

Vector Network Analyzer



DUT

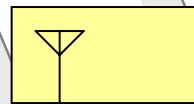

1.2.1.1 Test Procedure

1. Calibrate the vector network analyzer for one port reflection calibration with frequency range from 1GHz to 6GHz.
2. Solder a 50-ohm RF cable with a SMA connector on PCBA and assemble all the accessories and the housing.
3. Connect the network analyzer cable to the DUT through an SMA connector to antenna.
4. Measure and record S11 (return loss).

1.3 Radiation Pattern (Gain) Test

Test Equipment

1. AMS-8500 System
 - ◆ Rectangular anechoic chamber
 - ◆ Multi-Axis Positioning System (MAPS)
 - ◆ EMQuest EMQ-100 Data Acquisition and Analysis Software
 - ◆ ETS-Lindgren EMCO 3164-04 dual-polarized quad-ridged horn antenna
2. Network Analyzer: Agilent PNA, 300kHz ~ 6GHz

3. Signal Generator: R&S SMT6, 5kHz ~ 6GHz
4. Spectrum Analyzer: R&S FSP, 9kHz ~ 13.6GHz
5. Phantom Head: IEEE SCC34 "SAM" phantom per IEEE 1528-2002 specifications.



Test Lab & Method:

1. Test Lab: Foxlink RTC Lab
2. Test Method: 3D radiation pattern

Test Architecture

Typical AMS-8500 System Schematic

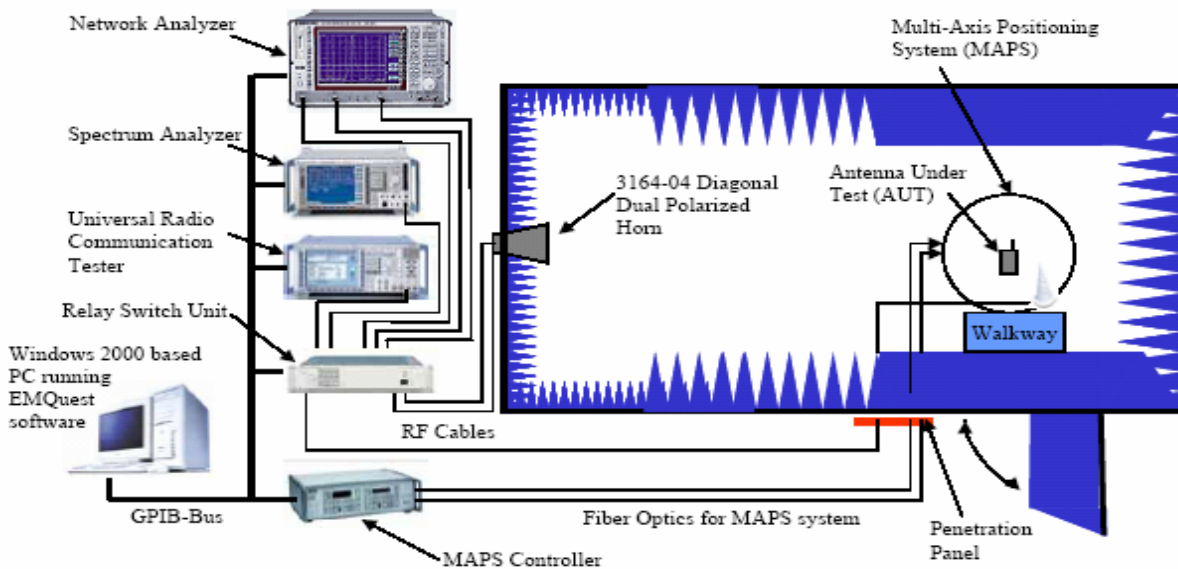

2 TEST RESULT AND SUMMARY

2.1 Return Loss Test Summary

	2402MHz	2441MHz	2480MHz
Black-1	-9	-16	-10
Black-2	-13	-14	-8

Unit: dB

2.2 Talking mode_Radiation Pattern at 2402,2441,2480 MHz

		2480MHz	2402MHz	2441MHz	Limit	result
Black-1	Average (dBi)	-7.24	-7.58	-8.41	>=-5	Fail
	Peak (dBi)	-1.27	-1.55	-2.55	>=-3	Pass
Black-2	Average (dBi)	-7.53	-7.46	-8.22	>=-5	Fail
	Peak (dBi)	-3.16	-2.87	-3.04	>=-3	Fail

Unit: dB

2.3 Return Loss and Radiation Pattern Results

Return Loss Result

Phantom Head:

BLACK-1

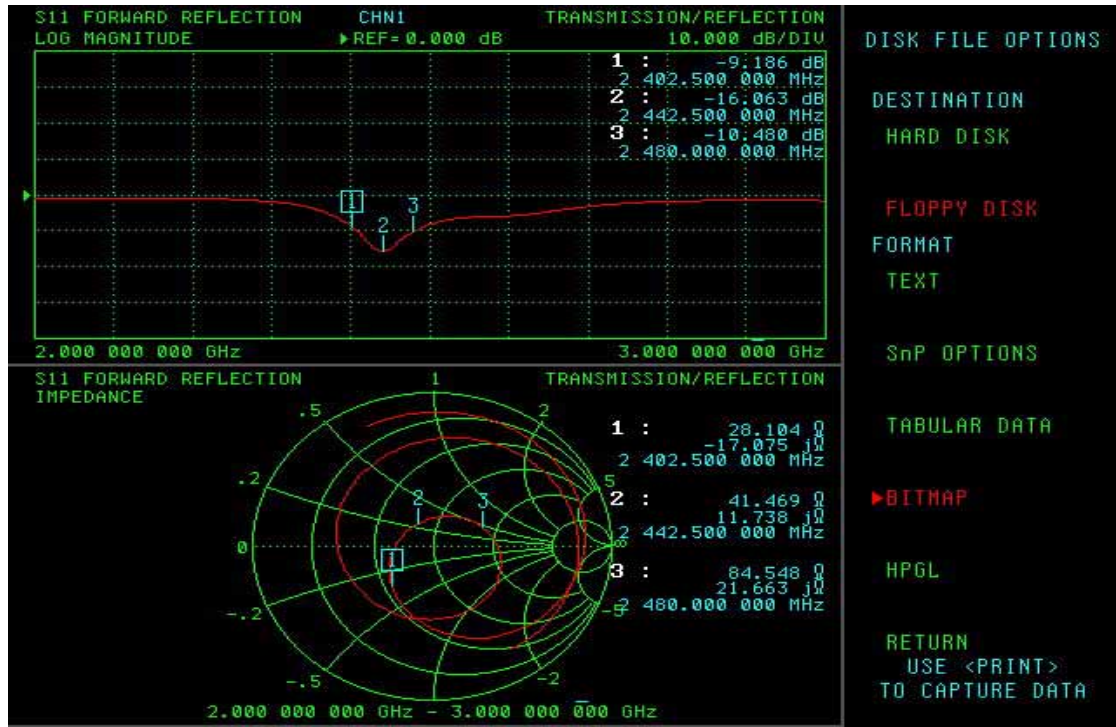

BLACK-2

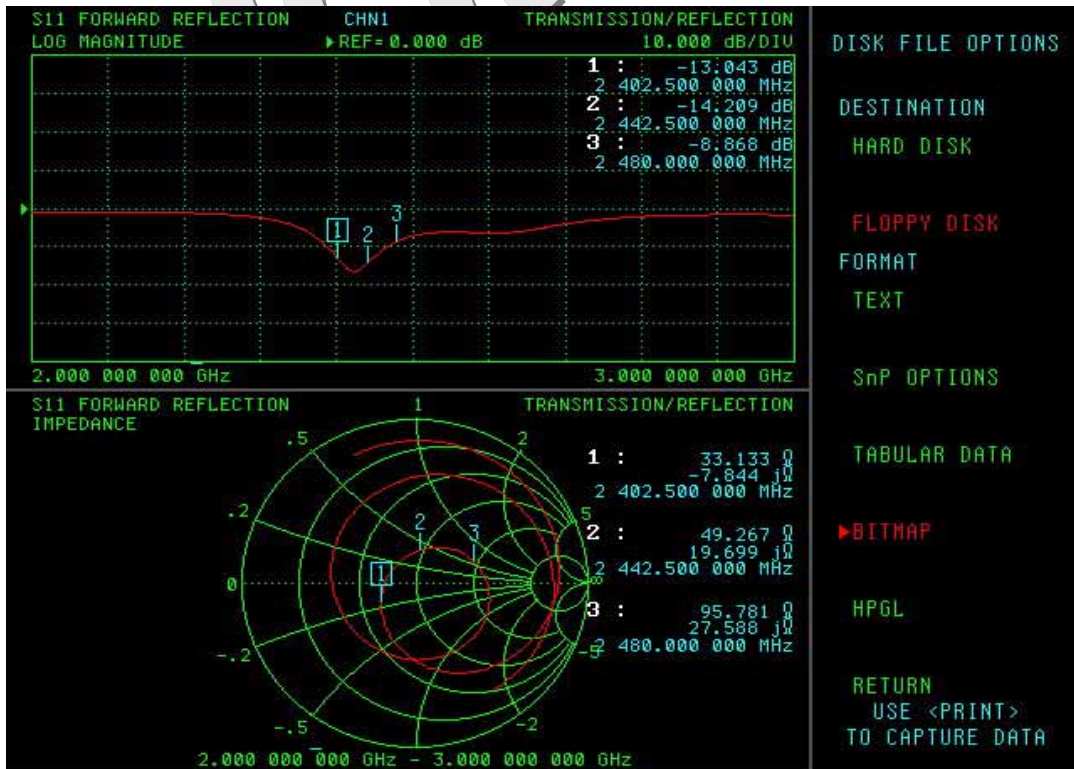

3D Radiation Pattern @ 2402,2441,2480MHz

Phantom Head:

BLACK-1_2441MHz

Black-1.pdf

BLACK-2_2441MHz

Black-2.pdf

MICROLINK