

Technical Description:

The Equipment Under Test (EUT) is a portable heart rate sensor, equipped with USB, Bluetooth 4.0 and ANT+ Interface. The EUT operates in frequency 2457MHz at ANT+ (1 channel with 1MHz spacing) and also operates in the frequency range 2402MHz to 2480MHz at Bluetooth 4.0 (40 channels with 2MHz spacing). The EUT is powered by 1 X 3.7V rechargeable battery (Li-Poly). The USB interface of the EUT do not contain PC Connectivity which the USB interface is for charging use only.

The brief circuit description is listed as follows:

1. Bluetooth 4.0 and ANT+ RF Portion

- 1) U3 (nRF51422) is a single-chip ANT+ and Bluetooth 4.0+EDR compliant 2.4GHz RF SoC processor.
- 2) Y3 is 32.768 kHz crystal for Real Time Clock.
- 3) Y1 is 16MHz crystal oscillator providing clock for U3.
- 4) U7 (AT24C02C) is an I2C compatible serial EEPROM.

2. Microcontroller Portion

- 1) U12 (MSP430F5510) is mixed signal microcontroller.
- 2) X13 is 8MHz crystal oscillator providing clock for U12.
- 3) U20 (MMA8452Q) is a three axes linear accelerometer.

3. Optical Sensor Portion

- 1) U13 (ADS11115) is a 16-bit analog to digital converter.
- 2) U8 and U9 (TS5A9411) are analog switches.
- 3) U3 and U4 (MCP6293) are Rail to Rail Op Amps.
- 4) U15 (MCP4531) is a Mixed Signal- Digital Potentiometer.

4. USB Charging and power supply circuit Portion

- 1) U10 (MCP73832) is a charge management controller.
- 2) U1 (TPS61222) is a 5V step-up voltage converter.
- 3) U6 (UP49A) is a battery protection IC.
- 4) U2 (HSNT-4) is a 2.7V voltage regulator.

When the ANT+ was stand-alone emitting, the ANT+ portion emission is as below:

Antenna Type: Internal integral antenna

Antenna Gain: -1.1dBi

Production tolerance: -12dBm (Minimum) to -4dBm (Maximum)

When the Bluetooth 4.0 was stand-alone emitting, the Bluetooth 4.0 portion emission is as below:

Antenna Type: Internal integral antenna

Antenna Gain: -1.1dBi

Production tolerance: -11dBm (Minimum) to -3dBm (Maximum)



nRF51422

Multiprotocol ANT™/Bluetooth® low energy System on Chip

Product Specification v2.1

Key Features

- 2.4 GHz transceiver
 - -90 dBm sensitivity in ANT mode
 - -93 dBm sensitivity in Bluetooth® low energy mode
 - 250 kbps, 1 Mbps, 2 Mbps supported data rates
 - TX Power -20 to +4 dBm in 4 dB steps
 - TX Power -30 dBm Whisper mode
 - 13 mA peak RX, 10.5 mA peak TX (0 dBm)
 - RSSI (1 dB resolution)
- ARM® Cortex™-M0 32 bit processor
 - 275 µA/MHz running from flash memory
 - 150 µA/MHz running from RAM
 - Serial Wire Debug (SWD)
- S200 and S300 series SoftDevice ready
- Memory
 - 256 kB or 128 kB embedded flash program memory
 - 16 kB RAM
- On-air compatibility with nRF24L series
- Flexible Power Management
 - Supply voltage range 1.8 V to 3.6 V
 - 2.5 µs wake-up using 16 MHz RCOSC
 - 0.6 µA at 3 V OFF mode
 - 1.2 µA at 3 V in OFF mode + 1 region RAM retention
 - 2.6 µA at 3 V ON mode, all blocks IDLE
- 8/9/10 bit ADC - 8 configurable channels
- 31 General Purpose I/O Pins
- One 32 bit and two 16 bit timers with counter mode
- SPI Master/Slave
- Low power comparator
- Temperature sensor
- Two-wire Master (I2C compatible)
- UART (CTS/RTS)
- CPU independent Programmable Peripheral Interconnect (PPI)
- Quadrature Decoder (QDEC)
- AES HW encryption
- Real Timer Counter (RTC)
- Package variants
 - QFN48 package, 6 x 6 mm
 - WLCSP package, 3.50 x 3.83 mm

Applications

- Personal Area Networks
 - Health/fitness sensor and monitor devices
 - Medical devices
 - Key-fobs + wrist watches
- Remote control toys
- Home/industrial automation
- Environmental sensor networks
- Active RFID
- Logistics/goods tracking
- Audience-response systems
- Interactive entertainment devices
 - Remote control
 - 3D Glasses
 - Gaming controller

Liability disclaimer

Nordic Semiconductor ASA reserves the right to make changes without further notice to the product to improve reliability, function or design. Nordic Semiconductor ASA does not assume any liability arising out of the application or use of any product or circuits described herein.

Life support applications

Nordic Semiconductor's products are not designed for use in life support appliances, devices, or systems where malfunction of these products can reasonably be expected to result in personal injury. Nordic Semiconductor ASA customers using or selling these products for use in such applications do so at their own risk and agree to fully indemnify Nordic Semiconductor ASA for any damages resulting from such improper use or sale.

Contact details

For your nearest distributor, please visit www.nordicsemi.com.

Information regarding product updates, downloads, and technical support can be accessed through your My Page account on our home page.

Main office: Otto Nielsens veg 12
7052 Trondheim
Norway

Phone: +47 72 89 89 00
Fax: +47 72 89 89 89

Mailing address: Nordic Semiconductor
P.O. Box 2336
7004 Trondheim
Norway



RoHS and REACH statement

Nordic Semiconductor's products meet the requirements of Directive 2002/95/EC of the European Parliament and of the Council on the Restriction of Hazardous Substances (RoHS) and the requirements of the REACH regulation (EC 1907/2006) on Registration, Evaluation, Authorization and Restriction of Chemicals. The SVHC (Substances of Very High Concern) candidate list is continually being updated. Complete hazardous substance reports, material composition reports and latest version of Nordic's REACH statement can be found on our website www.nordicsemi.com.

Datasheet Status

| Status | Description |
|---|---|
| Objective Product Specification (OPS) | This product specification contains target specifications for product development. |
| Preliminary Product Specification (PPS) | This product specification contains preliminary data; supplementary data may be published from Nordic Semiconductor ASA later. |
| Product Specification (PS) | This product specification contains final product specifications. Nordic Semiconductor ASA reserves the right to make changes at any time without notice in order to improve design and supply the best possible product. |

Revision History

| Date | Version | Description |
|---------------|---------|---|
| February 2014 | 2.1 | <p>Added content about the nRF51422-QFAB chip variant.</p> <p>Updated content:</p> <ul style="list-style-type: none"> • <i>Chapter 3.2.1 "Code organization"</i> on page 17 • <i>Chapter 3.2.2 "RAM organization"</i> on page 17 • <i>Chapter 3.3 "Memory Protection Unit (MPU)"</i> on page 17 • <i>Chapter 10.7.1 "nRF ICs"</i> on page 60 • <i>Chapter 11.2.1.1 "Bill of Materials"</i> on page 63 • <i>Chapter 11.2.2.1 "Bill of Materials"</i> on page 65 • <i>Chapter 11.2.3.1 "Bill of Materials"</i> on page 67 |

| Date | Version | Description |
|---------------|---------|---|
| December 2013 | 2.0 | <p>This version of the document will target the nRF51422 QFAA E0 revision and the nRF51422 CEAA B0 revision of the chip. If you are working with a previous revision of the chip, read version 1.2 or earlier of the document.</p> <p>Added content:</p> <ul style="list-style-type: none"> • <i>Section 3.3 “Memory Protection Unit (MPU)”</i> on page 17 • <i>Section 4.5 “AES CCM Mode Encryption (CCM)”</i> on page 25 • <i>Section 4.6 “Accelerated Address Resolver (AAR)”</i> on page 26 • <i>Section 4.16 “Low Power Comparator (LPCOMP)”</i> on page 28 • <i>Section 8.5.6 “Antenna matching network requirements”</i> on page 44 • <i>Section 8.8 “Serial Peripheral Interface Slave (SPIS) specifications”</i> on page 46 • <i>Section 8.18 “AES CCM Mode Encryption (CCM) specifications”</i> on page 51 • <i>Section 8.19 “Accelerated Address Resolver (AAR) specifications”</i> on page 51 • <i>Section 8.24 “Low Power Comparator (LPCOMP) specifications”</i> on page 53 <p>Updated content:</p> <ul style="list-style-type: none"> • Feature list on the Front page • <i>Chapter 1 “Introduction”</i> on page 8 • <i>Section 1.1 “Required reading”</i> on page 8 • <i>Section 2.1 “Block diagram”</i> on page 9 • <i>Section 2.2 “Pin assignments and functions”</i> on page 10 • <i>Section 3.2 “Memory”</i> on page 16 • <i>Section 3.5 “Programmable Peripheral Interconnect (PPI)”</i> on page 19 • <i>Section 3.7 “GPIO”</i> on page 23 • <i>Chapter 4 “Peripheral blocks”</i> on page 24 • <i>Section 4.1 “2.4 GHz radio (RADIO)”</i> on page 24 • <i>Section 4.2 “Timer/counters (TIMER)”</i> on page 25 • <i>Section 4.3 “Real Time Counter (RTC)”</i> on page 25 • <i>Section 4.10 “Serial Peripheral Interface (SPI/SPIS)”</i> on page 27 • <i>Section 4.12 “Universal Asynchronous Receiver/Transmitter (UART)”</i> on page 28 • <i>Section 4.14 “Analog to Digital Converter (ADC)”</i> on page 28 • <i>Section 4.15 “GPIO Task Event blocks (GPIOTE)”</i> on page 28 • <i>Chapter 5 “Instance table”</i> on page 29 • <i>Chapter 6 “Absolute maximum ratings”</i> on page 30 • <i>Section 8.1.2 “16 MHz crystal oscillator (16M XOSC)”</i> on page 33 • <i>Section 8.1.3 “32 MHz crystal oscillator (32M XOSC)”</i> on page 34 • <i>Section 8.1.5 “32.768 kHz crystal oscillator (32k XOSC)”</i> on page 35 • <i>Section 8.2 “Power management”</i> on page 37 • <i>Section 8.3 “Block resource requirements”</i> on page 39 • <i>Section 8.5.1 “General radio characteristics”</i> on page 40 • <i>Section 8.5.4 “Receiver specifications”</i> on page 42 • <i>Section 8.5.5 “Radio timing parameters”</i> on page 44 • <i>Section 8.7 “Universal Asynchronous Receiver/Transmitter (UART) specifications”</i> on page 45 • <i>Section 8.9 “Serial Peripheral Interface (SPI) Master specifications”</i> on page 47 • <i>Section 8.11 “GPIO Tasks and Events (GPIOTE) specifications”</i> on page 49 • <i>Section 8.13 “Timer (TIMER) specifications”</i> on page 50 • <i>Section 8.16 “Random Number Generator (RNG) specifications”</i> on page 50 • <i>Chapter 10 “Ordering information”</i> on page 56 • <i>Section 11.1 “PCB guidelines”</i> on page 61 • <i>Section 11.2 “QFN48 package”</i> on page 62 • <i>Section 11.3 “WLCSP package”</i> on page 68 |

| Date | Version | Description |
|---------------|---------|--|
| April 2013 | 1.2 | Added chip variant nRF51422-CEAA. Updated feature list on front page. Updated Section 3.2.1 on page 15, Section 3.2.2 on page 15, Chapter 6 on page 28, Section 10.4 on page 52, and Section 10.5.1 on page 53. Added Section 2.2.2 on page 10, Section 7.1 on page 29, Section 9.2 on page 50, and Section 11.3 on page 61. Removed PCB layouts in Chapter 11 on page 54. |
| March 2013 | 1.1 | Added 32 MHz crystal oscillator feature. Moved subsection 'Calculating current when the DC/DC converter is enabled' from chapter 8 to the <i>nRF51 Series Reference Manual</i> . Updated Section 3.2 on page 12, Section 3.5 on page 16, Section 3.5.1 on page 17, Section 4.2 on page 21, Chapter 5 on page 24, Section 8.1 on page 27, Section 8.1.2 on page 28, Section 8.1.5 on page 30, Section 8.2 on page 32, Section 8.3 on page 34, Section 8.5.3 on page 36, Section 8.8 on page 40, Section 8.9 on page 41, Section 8.10 on page 42, and Section 8.14 on page 43. Added Section 3.5.4 on page 19, Section 8.1.3 on page 29, and Section 11.1 on page 50. |
| December 2012 | 1.0 | Changed from PPS to PS. Updated the feature list on the front page. Updated Section 3.5.3 on page 18, Table 10 on page 24, Table 11 on page 25, Table 12 on page 26, Table 14 on page 27, Table 15 on page 28, Table 16 on page 28, Table 17 on page 29, Table 19 on page 30, Table 20 on page 31, Table 22 on page 32, Table 23 on page 32, Table 24 on page 33, Table 25 on page 35, Table 26 on page 36, Table 28 on page 36, Table 29 on page 37, Table 30 on page 37, Table 32 on page 38, Table 33 on page 38, Table 36 on page 39, Section 8.16 on page 40, Table 39 on page 40, Table 40 on page 40, Table 56 on page 47, and the reference design in Chapter 11 on page 48. Added Section 3.5.4 on page 19 and Table 18 on page 29. |

Table of contents

| | | |
|----------|--|-----------|
| 1 | Introduction | 8 |
| 1.1 | Required reading..... | 8 |
| 1.2 | Writing conventions..... | 8 |
| 2 | Product overview | 9 |
| 2.1 | Block diagram..... | 9 |
| 2.2 | Pin assignments and functions..... | 10 |
| 3 | System blocks | 15 |
| 3.1 | CPU..... | 15 |
| 3.2 | Memory..... | 16 |
| 3.3 | Memory Protection Unit (MPU)..... | 17 |
| 3.4 | Power management (POWER)..... | 18 |
| 3.5 | Programmable Peripheral Interconnect (PPI)..... | 19 |
| 3.6 | Clock management (CLOCK)..... | 20 |
| 3.7 | GPIO..... | 23 |
| 3.8 | Debugger support..... | 23 |
| 4 | Peripheral blocks | 24 |
| 4.1 | 2.4 GHz radio (RADIO)..... | 24 |
| 4.2 | Timer/counters (TIMER)..... | 25 |
| 4.3 | Real Time Counter (RTC)..... | 25 |
| 4.4 | AES Electronic Codebook Mode Encryption (ECB)..... | 25 |
| 4.5 | AES CCM Mode Encryption (CCM)..... | 25 |
| 4.6 | Accelerated Address Resolver (AAR)..... | 26 |
| 4.7 | Random Number Generator (RNG)..... | 26 |
| 4.8 | Watchdog Timer (WDT)..... | 26 |
| 4.9 | Temperature sensor (TEMP)..... | 26 |
| 4.10 | Serial Peripheral Interface (SPI/SPIS)..... | 27 |
| 4.11 | Two-wire interface (TWI)..... | 27 |
| 4.12 | Universal Asynchronous Receiver/Transmitter (UART)..... | 28 |
| 4.13 | Quadrature Decoder (QDEC)..... | 28 |
| 4.14 | Analog to Digital Converter (ADC)..... | 28 |
| 4.15 | GPIO Task Event blocks (GPIOTE)..... | 28 |
| 4.16 | Low Power Comparator (LPCOMP)..... | 28 |
| 5 | Instance table | 29 |
| 6 | Absolute maximum ratings | 30 |
| 7 | Operating conditions | 31 |
| 7.1 | WLCSP light sensitivity..... | 31 |
| 8 | Electrical specifications | 32 |
| 8.1 | Clock sources..... | 32 |
| 8.2 | Power management..... | 37 |
| 8.3 | Block resource requirements..... | 39 |
| 8.4 | CPU..... | 39 |
| 8.5 | Radio transceiver..... | 40 |
| 8.6 | Received Signal Strength Indicator (RSSI) specifications..... | 44 |
| 8.7 | Universal Asynchronous Receiver/Transmitter (UART) specifications..... | 45 |
| 8.8 | Serial Peripheral Interface Slave (SPIS) specifications..... | 46 |

| | | |
|-----------|--|-----------|
| 8.9 | Serial Peripheral Interface (SPI) Master specifications | 47 |
| 8.10 | I2C compatible Two Wire Interface (TWI) specifications | 48 |
| 8.11 | GPIO Tasks and Events (GPIOTE) specifications..... | 49 |
| 8.12 | Analog to Digital Converter (ADC) specifications..... | 49 |
| 8.13 | Timer (TIMER) specifications..... | 50 |
| 8.14 | Real Time Counter (RTC) | 50 |
| 8.15 | Temperature sensor (TEMP) | 50 |
| 8.16 | Random Number Generator (RNG) specifications..... | 50 |
| 8.17 | AES Electronic Codebook Mode Encryption (ECB)specifications..... | 51 |
| 8.18 | AES CCM Mode Encryption (CCM) specifications | 51 |
| 8.19 | Accelerated Address Resolver (AAR) specifications..... | 51 |
| 8.20 | Watchdog Timer (WDT) specifications | 51 |
| 8.21 | Quadrature Decoder (QDEC) specifications | 52 |
| 8.22 | Non-Volatile Memory Controller (NVMC) specifications..... | 52 |
| 8.23 | General Purpose I/O (GPIO) specifications..... | 52 |
| 8.24 | Low Power Comparator (LPCOMP) specifications..... | 53 |
| 9 | Mechanical specifications | 54 |
| 9.1 | QFN48 package | 54 |
| 9.2 | WLCSP package..... | 55 |
| 10 | Ordering information | 56 |
| 10.1 | Chip marking..... | 56 |
| 10.2 | Inner box label..... | 56 |
| 10.3 | Outer box label..... | 57 |
| 10.4 | Order code | 57 |
| 10.5 | Abbreviations..... | 58 |
| 10.6 | Code ranges and values..... | 59 |
| 10.7 | Product options | 60 |
| 11 | Reference circuitry..... | 61 |
| 11.1 | PCB guidelines..... | 61 |
| 11.2 | QFN48 package..... | 62 |
| 11.3 | WLCSP package..... | 68 |
| 12 | Glossary | 74 |

1 Introduction

The nRF51422 is an ultra-low power 2.4 GHz wireless System on Chip (SoC) integrating the nRF51 series 2.4 GHz transceiver, a 32 bit ARM® Cortex™-M0 CPU, flash memory, and analog and digital peripherals. nRF51422 supports ANT, *Bluetooth*® low energy, and a range of proprietary 2.4 GHz protocols, such as Gazell from Nordic Semiconductor.

A range of fully qualified wireless protocol stacks for the nRF51422 are available as SoftDevices from www.nordicsemi.com.

nRF51422 supports the following SoftDevice series:

- S200 - ANT stacks
- S300 - ANT/*Bluetooth* low energy stack

Note: The S200 and S300 SoftDevices are restricted to run only on nRF51422 devices.

SoftDevices can be installed on the nRF51422 independent of your own application code.

1.1 Required reading

The following documentation is available for download from www.nordicsemi.com:

- *nRF51 Series Reference Manual*
- *nRF51422-PAN (Product Anomaly Notification)*
- *PCN-084 (nRF51422 Product Change Notification)*

1.2 Writing conventions

This product specification follows a set of typographic rules to ensure that the document is consistent and easy to read. The following writing conventions are used:

- Command, event names, and bit state conditions, are written in `Lucida Console`.
- Pin names and pin signal conditions are written in **Conso1as**.
- File names and User Interface components are written in **bold**.
- Internal cross references are italicized and written in *semi-bold*.
- Placeholders for parameters are written in italic regular text font. For example, a syntax description of Connect will be written as:
`Connect(TimeOut, AdvInterval).`
- Fixed parameters are written in regular text font. For example, a syntax description of Connect will be written as:
`Connect(0x00F0, Interval).`

2 Product overview

2.1 Block diagram

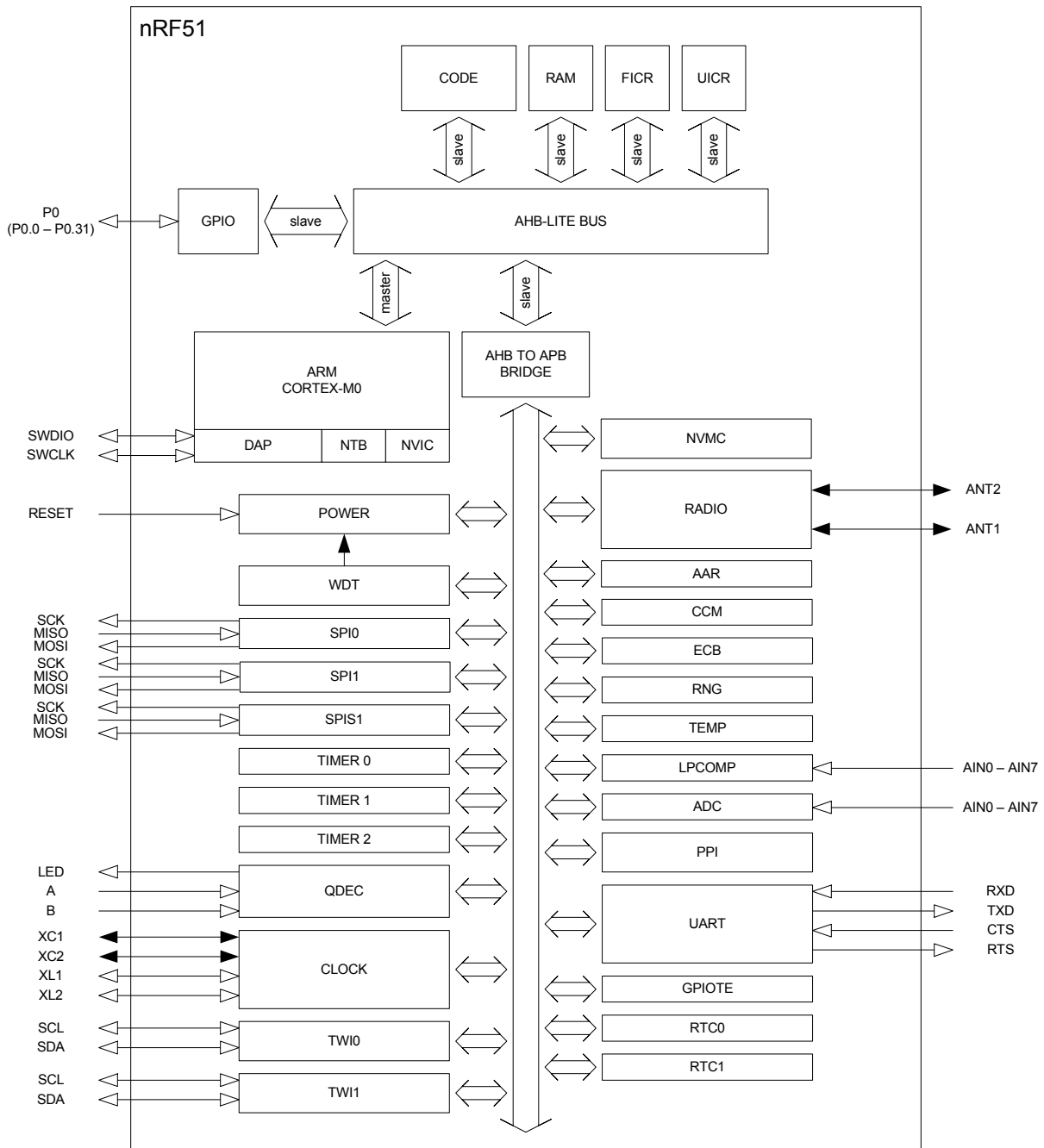

Figure 1 Block diagram

2.2 Pin assignments and functions

This section describes the pin assignment and the pin functions.

2.2.1 Pin assignment

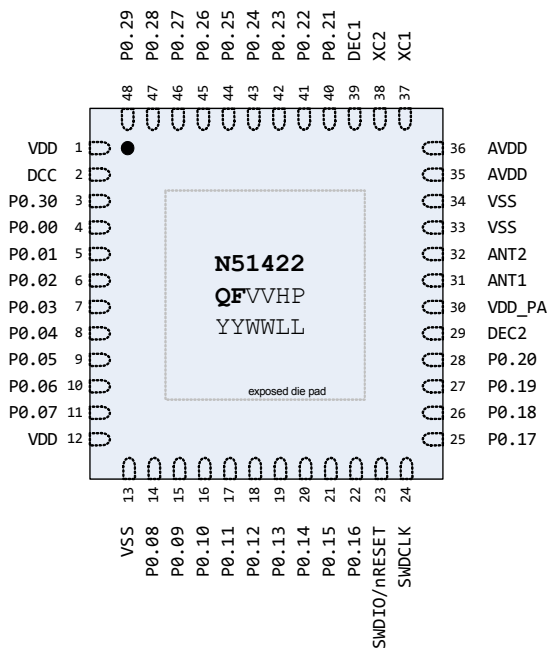

Figure 2 Pin assignment - QFN48 packet

Note: VV = Variant code, HP = Build code, YYWWLL = Tracking code.
For more information, see **Section 10.6 “Code ranges and values”** on page 59.

2.2.1.1 Pin functions

| Pin | Pin name | Pin function | Description |
|----------|------------------------|---|--|
| 1 | VDD | Power | Power supply. |
| 2 | DCC | Power | DC/DC output voltage to external LC filter. |
| 3 | P0.30 | Digital I/O | General purpose I/O pin. |
| 4 | P0.00 AREF0 | Digital I/O Analog input | General purpose I/O pin. ADC/LPCOMP reference input 0. |
| 5 | P0.01 AIN2 | Digital I/O Analog input | General purpose I/O pin. ADC/LPCOMP input 2. |
| 6 | P0.02 AIN3 | Digital I/O Analog input | General purpose I/O pin. ADC/LPCOMP input 3. |
| 7 | P0.03 AIN4 | Digital I/O Analog input | General purpose I/O pin. ADC/LPCOMP input 4. |
| 8 | P0.04 AIN5 | Digital I/O Analog input | General purpose I/O pin. ADC/LPCOMP input 5. |
| 9 | P0.05 AIN6 | Digital I/O Analog input | General purpose I/O pin. ADC/LPCOMP input 6. |
| 10 | P0.06 AIN7 AREF1 | Digital I/O Analog input Analog input | General purpose I/O pin. ADC/LPCOMP input 7. ADC/LPCOMP reference input 1. |
| 11 | P0.07 | Digital I/O | General purpose I/O pin. |
| 12 | VDD | Power | Power supply. |
| 13 | VSS | Power | Ground (0 V) ¹ . |
| 14 to 22 | P0.08 to P0.16 | Digital I/O | General purpose I/O pin. |
| 23 | SWDIO/nRESET | Digital I/O | System reset (active low). Also hardware debug and flash programming I/O. |
| 24 | SWDCLK | Digital input | Hardware debug and flash programming I/O. |
| 25 to 28 | P0.17 to P0.20 | Digital I/O | General purpose I/O pin. |
| 29 | DEC2 | Power | Power supply decoupling. |
| 30 | VDD_PA | Power output | Power supply output (+1.6 V) for on-chip RF power amp. |
| 31 | ANT1 | RF | Differential antenna connection (TX and RX). |
| 32 | ANT2 | RF | Differential antenna connection (TX and RX). |
| 33, 34 | VSS | Power | Ground (0 V). |
| 35, 36 | AVDD | Power | Analog Power supply for radio. |
| 37 | XC1 | Analog input | Connection for 16/32 MHz crystal or external 16 MHz clock reference. |
| 38 | XC2 | Analog output | Connection for 16/32 MHz crystal. |
| 39 | DEC1 | Power | Power supply decoupling. |

| Pin | Pin name | Pin function | Description |
|----------|-----------------|---------------|---|
| 40 to 44 | P0.21 to P0.25 | Digital I/O | General purpose I/O pin. |
| 45 | P0.26 | Digital I/O | General purpose I/O pin. |
| | AIN0 | Analog input | ADC/LPCOMP input 0. |
| | XL2 | Analog output | Connection for 32.768 kHz crystal. |
| 46 | P0.27 | Digital I/O | General purpose I/O pin. |
| | AIN1 | Analog input | ADC/LPCOMP input 1. |
| | XL1 | Analog input | Connection for 32.768 kHz crystal or external 32.768 kHz clock reference. |
| 47, 48 | P0.28 and P0.29 | Digital I/O | General purpose I/O pin. |

1. The exposed center pad of the QFN48 package must be connected to ground for proper device operation.

Table 1 Pin functions QFN48 packet

2.2.2 WLCSP ball assignment and functions

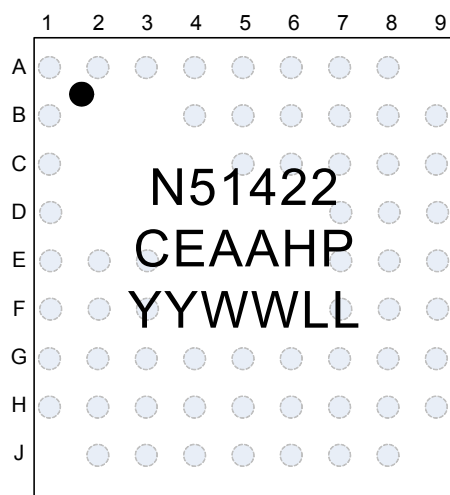

Figure 3 Ball assignment CEAA packet (top side view)

Note: HP = Buildcode, YYWWLL = Tracking code
Solder balls not visible on the top side. Dot denotes A1 corner.

| Ball | Name | Function | Description |
|------|-------|---------------|--|
| A1 | AVDD | Power | Analog power supply for radio. |
| A2 | XC1 | Analog input | Crystal connection for 16/32 MHz crystal oscillator or external 16/32 MHz crystal reference. |
| A3 | XC2 | Analog output | Crystal connection for 16/32 MHz crystal. |
| A4 | DEC1 | Power | Power supply decoupling. |
| A5 | P0.21 | Digital I/O | General purpose I/O. |
| A6 | P0.24 | Digital I/O | General purpose I/O. |
| | P0.26 | Digital I/O | General purpose I/O. |
| | AIN0 | Analog input | ADC input 0. |
| A7 | XL2 | Analog output | Crystal connection for 32.768 kHz crystal oscillator. |

| Ball | Name | Function | Description |
|------|----------------------|---|--|
| A8 | P0.27 AIN1 XL1 | Digital I/O Analog input Analog input | General purpose I/O. ADC input 1. Crystal connection for 32.768 kHz crystal oscillator or external 32.768 kHz crystal reference. |
| B1 | VSS | Power | Ground (0 V). |
| B4 | VSS | Power | Ground (0 V). |
| B5 | P0.22 | Digital I/O | General purpose I/O. |
| B6 | P0.23 | Digital I/O | General purpose I/O. |
| B7 | P0.28 | Digital I/O | General purpose I/O. |
| B8 | VDD | Power | Power supply. |
| B9 | DCC | Power | DC/DC output voltage to external LC filter. |
| C1 | ANT2 | RF | Differential antenna connection (TX and RX). |
| C5 | P0.25 | Digital I/O | General purpose I/O. |
| C6 | N.C. | No Connection | Must be soldered to PCB. |
| C7 | P0.29 | Digital I/O | General purpose I/O. |
| C8 | VSS | Power | Ground (0 V). |
| C9 | P0.00 AREF0 | Digital I/O Analog input | General purpose I/O. ADC Reference voltage. |
| D1 | ANT1 | RF | Differential antenna connection (TX and RX). |
| D7 | VSS | Power | Ground (0 V). |
| D8 | P0.30 | Digital I/O | General purpose I/O. |
| D9 | P0.02 AIN3 | Digital I/O Analog input | General purpose I/O. ADC input 3. |
| E1 | VDD_PA | Power output | Power supply output (+1.6 V) for on-chip RF power amp. |
| E2 | N.C. | No Connection | Must be soldered to PCB. |
| E3 | N.C. | No Connection | Must be soldered to PCB. |
| E7 | N.C. | No Connection | Must be soldered to PCB. |
| E8 | P0.31 | Digital I/O | General purpose I/O. |
| E9 | P0.01 AIN2 | Digital I/O Analog input | General purpose I/O. ADC input 2. |
| F1 | DEC2 | Power | Power supply decoupling. |
| F2 | P0.19 | Digital I/O | General purpose I/O. |
| F3 | N.C. | No Connection | Must be soldered to PCB. |
| F7 | N.C. | No Connection | Must be soldered to PCB. |
| F8 | P0.04 AIN5 | Digital I/O Analog input | General purpose I/O. ADC input 5. |
| F9 | P0.03 AIN4 | Digital I/O Analog input | General purpose I/O. ADC input 4. |
| G1 | P0.20 | Digital I/O | General purpose I/O. |
| G2 | P0.17 | Digital I/O | General purpose I/O. |
| G3 | N.C. | No Connection | Must be soldered to PCB. |

| Ball | Name | Function | Description |
|------|------------------|---------------|---|
| G4 | N.C. | No Connection | Must be soldered to PCB. |
| G5 | N.C. | No Connection | Must be soldered to PCB. |
| G6 | VSS | Power | Ground (0 V). |
| G7 | N.C. | No Connection | Must be soldered to PCB. |
| G8 | P0.06 | Digital I/O | General purpose I/O. |
| | AIN7 | Analog input | ADC input 7. |
| | AREF1 | Analog input | ADC Reference voltage. |
| G9 | VSS | Power | Ground (0 V). |
| H1 | P0.18 | Digital I/O | General purpose I/O. |
| H2 | SWDCLK | Digital input | Hardware debug and flash programming I/O. |
| H3 | VSS | Power | Ground (0 V). |
| H4 | P0.14 | Digital I/O | General purpose I/O. |
| H5 | P0.13 | Digital I/O | General purpose I/O. |
| H6 | P0.10 | Digital I/O | General purpose I/O. |
| H7 | P0.07 | Digital I/O | General purpose I/O. |
| H8 | VDD | Power | Power supply. |
| H9 | P0.05 | Digital I/O | General purpose I/O. |
| | AIN6 | Analog input | ADC input 6. |
| J2 | SWDIO/ nRESET | Digital I/O | System reset (active low). Also Hardware debug and flash programming I/O. |
| J3 | P0.16 | Digital I/O | General purpose I/O. |
| J4 | P0.15 | Digital I/O | General purpose I/O. |
| J5 | P0.12 | Digital I/O | General purpose I/O. |
| J6 | P0.11 | Digital I/O | General purpose I/O. |
| J7 | P0.09 | Digital I/O | General purpose I/O. |
| J8 | P0.08 | Digital I/O | General purpose I/O. |

Table 2 Ball functions for CEAA

3 System blocks

The chip contains system-level features common to all nRF51 series devices including clock control, power and reset, interrupt system, Programmable Peripheral Interconnect (PPI), watchdog, and GPIO.

System blocks which have a register interface and/or interrupt vector assigned are instantiated in the device address space. The instances of system blocks, their associated ID (for those with interrupt vectors), and base addresses are found in **Table 15** on page 29. Detailed functional descriptions, configuration options, and register interfaces can be found in the *nRF51 Series Reference Manual*.

3.1 CPU

The ARM® Cortex™-M0 CPU has a 16 bit instruction set with 32 bit extensions ([Thumb-2® technology](#)) that delivers high-density code with a small-memory-footprint. By using a single-cycle 32 bit multiplier, a 3-stage pipeline, and a Nested Vector Interrupt Controller (NVIC), the ARM Cortex-M0 CPU makes program execution simple and highly efficient.

The ARM Cortex Microcontroller Software Interface Standard (CMSIS) hardware abstraction layer for the ARM Cortex-M processor series is implemented and available for M0 CPU. Code is forward compatible with ARM Cortex M3 based devices.

3.2 Memory

All memory and registers are found in the same address space as shown in the Device Memory Map, see **Figure 4**. Devices in the nRF51 series use flash based memory in the code, FICR, and UICR regions. The RAM region is SRAM.

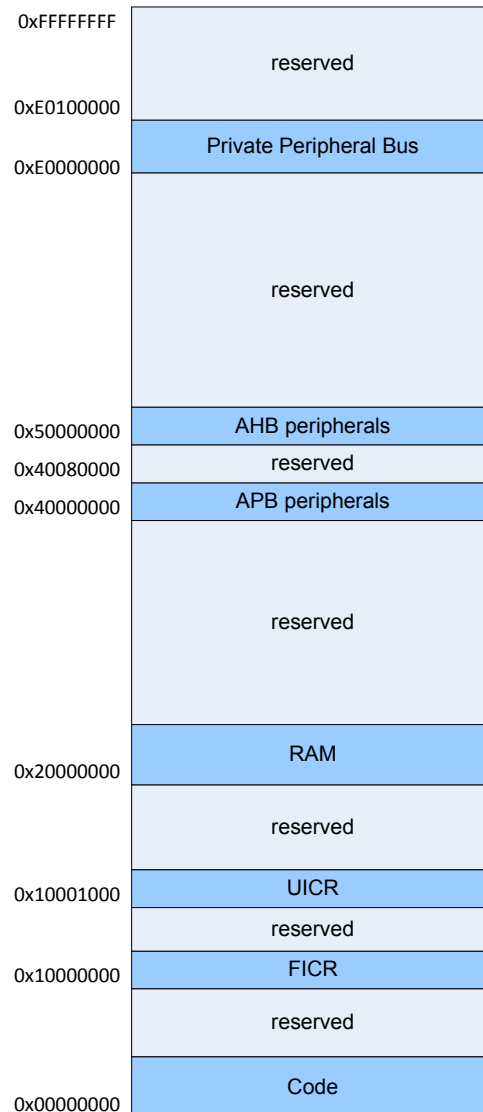

Figure 4 Memory Map

The embedded flash memory for program and static data can be programmed using In Application Programming (IAP) routines from RAM through the SWD interface, or in-system from a program executing from code area. The Non-Volatile Memory Controller (NVMC) is used for program/erase operations. Regions of flash memory can be protected from read, write, and erase by the Memory Protection Unit (MPU). A User Information Configuration Register (UICR) contains the lock byte for enabling readback protection to secure the IP, while individual block protection is controlled using registers which can only be cleared on chip reset.

3.2.1 Code organization

| Chip variant | Code size | Page size | No of pages |
|--------------------------------|-----------|-----------|-------------|
| nRF51422-QFAA nRF51422-CEAA | 256 kB | 1024 byte | 256 |
| nRF51422-QFAB | 128 kB | 1024 byte | 128 |

Table 3 Code organization

3.2.2 RAM organization

RAM is divided into blocks for separate power management which is controlled by the POWER System Block. Please see the *nRF51 Series Reference Manual* for more information.

| Chip variant | RAM size | Block | Start address | Size |
|---|----------|------------------|--------------------------|--------------|
| nRF51422-QFAA nRF51422-QFAB nRF51422-CEAA | 16 kB | Block0 Block1 | 0x20000000 0x20002000 | 8 kB 8 kB |

Table 4 RAM organization

3.3 Memory Protection Unit (MPU)

The memory protection unit can be configured to protect all flash memory on the device from readback, or to protect blocks of flash from over-write or erase.

| Chip variant | Flash block size | Number of protectable Flash blocks |
|---------------|------------------|------------------------------------|
| nRF51422-QFAA | 4 kB | 64 |
| nRF51422-QFAB | 4 kB | 32 |
| nRF51422-CEAA | 4 kB | 64 |

Table 5 MPU flash blocks

3.4 Power management (POWER)

The power management system is highly flexible with functional blocks such as the CPU, Radio Transceiver, and peripherals having separate power state control in addition to the global System ON and OFF modes. In System OFF mode, RAM can be retained and the device state can be changed to System ON through reset or a GPIO signal. When in System ON mode, all functional blocks will independently be in IDLE or RUN mode depending on needed functionality.

Power management features:

- System ON/OFF modes
- Brownout reset
- Power fail comparator
- Pin wake-up from System OFF
- Functional block RUN/IDLE modes
- Two region RAM retention in System OFF mode

Power supply features:

- Supervisor hardware to manage power on reset, brownout, and power failure
- Supply voltage range of 1.8 to 3.6 V using internal LDO regulator
- Low voltage mode of 1.75 to 1.95 V (external voltage regulator is required)
- Supply voltage range of 2.1 to 3.6 V using internal buck DC/DC converter

3.4.1 Low voltage mode

Devices can be used in low voltage mode where a steady 1.8 V supply is available externally. To use the device in the low voltage mode, the circuit must be modified according to the reference circuitry provided in *Section 11.2.2 “QFN48 schematic with 1.8 V low voltage mode”* on page 64 or *Section 11.3.2 “WLCSP schematic with 1.8 V low voltage mode”* on page 70.

3.4.2 DC/DC converter

The nRF51 DC/DC buck converter transforms battery voltage to lower internal voltage with minimal power loss. The converted voltage is then available for the linear regulator input. The DC/DC converter can be disabled when the supply voltage drops to the lower limit of the voltage range so the LDO can be used for low supply voltages. When enabled, the DC/DC converter operation is automatically suspended when only the low current regulator is needed internally.

This feature is particularly useful for applications using battery technologies with higher nominal cell voltages. The reduction in supply voltage level from a high voltage to a low voltage reduces the peak power drain from the battery. Used with a 3 V coin-cell battery, the peak current drawn from the battery is reduced by approximately 30%.

Note: Three external passive components are required in order to use the DC/DC converter. See *Section 11.2.3 “QFN48 schematic with internal DC/DC converter”* on page 66 for details on the schematic differences.

3.5 Programmable Peripheral Interconnect (PPI)

The Programmable Peripheral Interconnect (PPI) enables peripherals to interact autonomously with each other using tasks and events independent of the CPU. The PPI allows precise synchronization between peripherals when real-time application constraints exist and eliminates the need for CPU activity to implement behavior which can be predefined using PPI.

| Instance | Channel | Number of channels | Number of groups |
|----------|---------|--------------------|------------------|
| PPI | 0 - 15 | 16 | 4 |

Table 6 PPI properties

The PPI system has in addition to the fully programmable peripheral interconnections, a set of channels where the event (EEP) and task (TEP) endpoints are set in hardware. These fixed channels can be individually enabled, disabled, or added to PPI channel groups in the same way as ordinary PPI channels. See the *nRF51 Series Reference Manual* for more information.

| Instance | Channel | Number of channels | Number of groups |
|----------|---------|--------------------|------------------|
| PPI | 20 - 31 | 12 | 4 |

Table 7 Pre-programmed PPI channels

3.6 Clock management (CLOCK)

The advanced clock management system can source the system clocks from a range of internal or external high and low frequency oscillators and distribute them to modules based upon a module's individual requirements. This prevents large clock trees from being active and drawing power when system modules needing this clock reference are not active.

If an application enables a module that needs a clock reference without the corresponding oscillator running, the clock management system will automatically enable the RC oscillator option and provide the clock. When the module goes back to idle, the clock management will automatically set the oscillator to idle. To avoid delays involved in starting a given oscillator, or if a specific oscillator is required, the application can override the automatic oscillator management so it keeps oscillators active when no system modules require the clock reference.

Clocks are only available in System ON mode and can be generated by the sources listed in **Table 8**.

| Clock | Source | Frequency options |
|---|---------------------------------------|------------------------|
| High Frequency Clock (HFCLK) ¹ | External Crystal (XOSC) | 16/32 MHz ² |
| | External clock reference ³ | 16 MHz |
| | Internal RC Oscillator (RCOSC) | 16 MHz |
| Low Frequency Clock (LFCLK) | External Crystal (XOSC) | 32.768 kHz |
| | External clock reference ³ | 32.768 kHz |
| | Synthesized from HFCLK | 32.768 kHz |
| | Internal RC Oscillator (RCOSC) | 32.768 kHz |

1. External Crystal must be used for Radio operation.
2. The HFCLK will be 16 MHz for both the 16 and 32 MHz crystal option.
3. See the *nRF51 Series Reference Manual* for more details on external clock reference.

Table 8 Clock properties

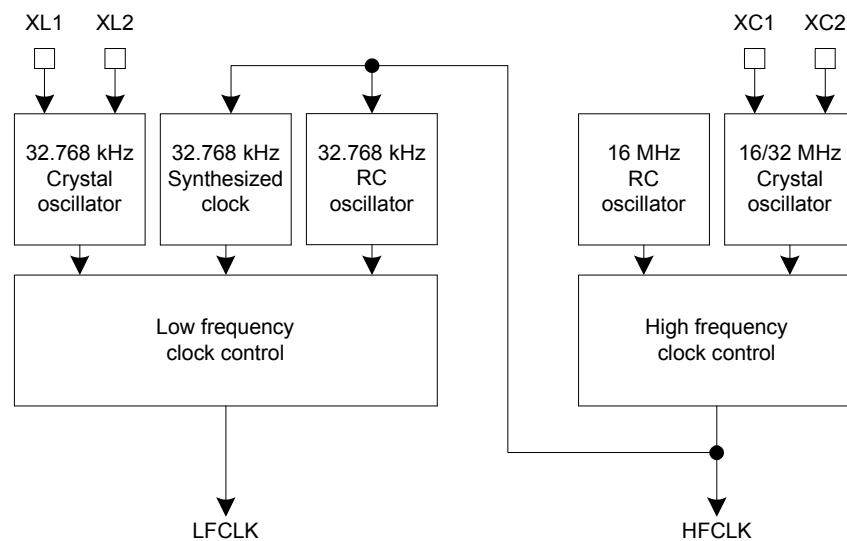

Figure 5 Clock management

3.6.1 16/32 MHz crystal oscillator

The crystal oscillator can be controlled either by a 16 MHz or a 32 MHz external crystal. However, the system clock is always 16 MHz, see the *nRF51 Series Reference Manual* for more details. The crystal oscillator is designed for use with an AT-cut quartz crystal in parallel resonant mode. To achieve correct oscillation frequency, the load capacitance must match the specification in the crystal data sheet. **Figure 6** shows how the crystal is connected to the 16/32 MHz crystal oscillator.

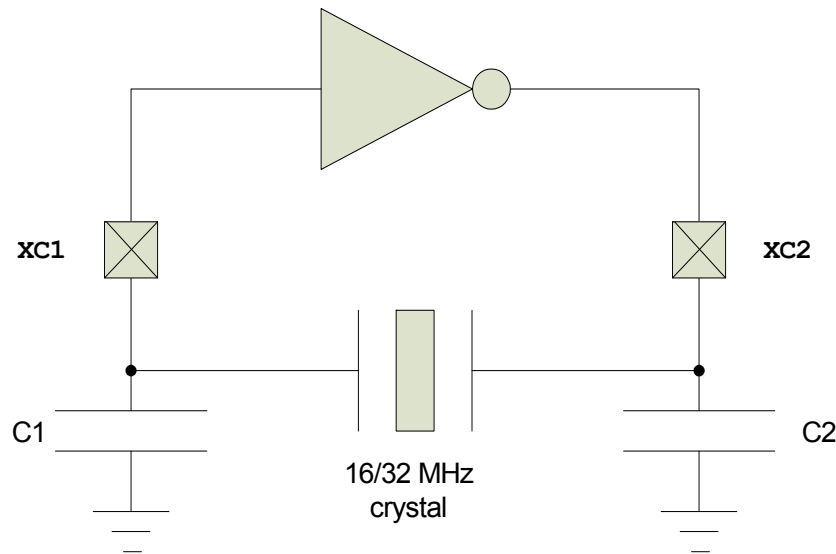

Figure 6 Circuit diagram of the 16/32 MHz crystal oscillator

The load capacitance (CL) is the total capacitance seen by the crystal across its terminals and is given by:

$$CL = \frac{(C1' \cdot C2')}{(C1' + C2')}$$

$$C1' = C1 + C_{pcb1} + C_{pin}$$

$$C2' = C2 + C_{pcb2} + C_{pin}$$

C1 and C2 are ceramic SMD capacitors connected between each crystal terminal and ground. C_{pcb1} and C_{pcb2} are stray capacitances on the PCB. C_{pin} is the pin input capacitance on the XC1 and XC2 pins, see **Table 19** on page 33 (16 MHz) and **Table 20** on page 34 (32 MHz). The load capacitors C1 and C2 should have the same value. See **Chapter 11 "Reference circuitry"** on page 61 for the capacitance value used for C_{pcb1} and C_{pcb2} in reference circuitry.

For reliable operation, the crystal load capacitance, shunt capacitance, equivalent series resistance ($R_{S,X16M}/R_{S,X32M}$), and drive level must comply with the specifications in **Table 19** on page 33 (16 MHz) and **Table 20** on page 34 (32 MHz). It is recommended to use a crystal with lower than maximum $R_{S,X16M}/R_{S,X32M}$ if the load capacitance and/or shunt capacitance is high. This will give faster startup and lower current consumption. A low load capacitance will reduce both startup time and current consumption.

3.6.2 32.768 kHz crystal oscillator

The 32.768 kHz crystal oscillator is designed for use with a quartz crystal in parallel resonant mode. To achieve correct oscillation frequency, the load capacitance must match the specification in the crystal data sheet. **Figure 7** shows how the crystal is connected to the 32.768 kHz crystal oscillator.

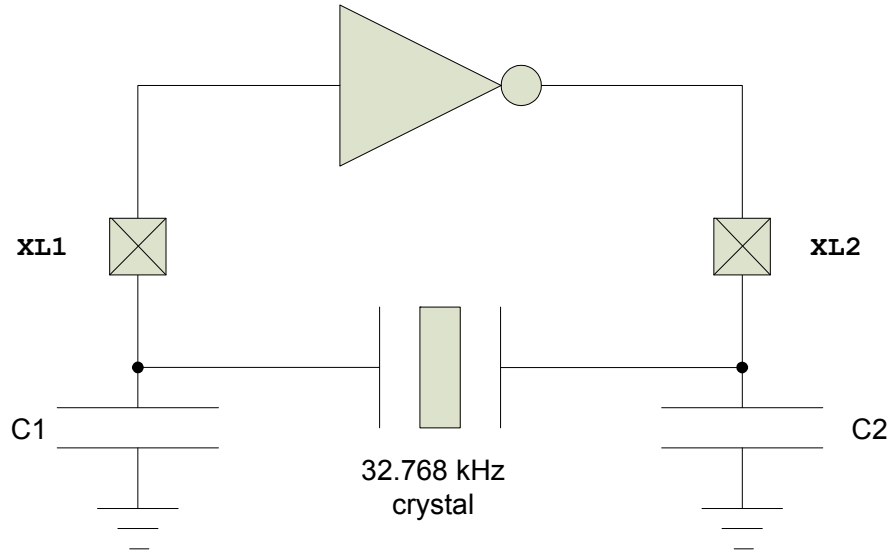

Figure 7 Circuit diagram of the 32.768 kHz crystal oscillator

The load capacitance (CL) is the total capacitance seen by the crystal across its terminals and is given by:

$$CL = \frac{(C1' \cdot C2')}{(C1' + C2')}$$

$$C1' = C1 + C_{pcb1} + C_{pin}$$

$$C2' = C2 + C_{pcb2} + C_{pin}$$

C1 and C2 are ceramic SMD capacitors connected between each crystal terminal and ground. C_{pcb1} and C_{pcb2} are stray capacitances on the PCB. C_{pin} is the pin input capacitance on the XC1 and XC2 pins, see **Section 8.1.5 "32.768 kHz crystal oscillator (32k XOSC)"** on page 35. The load capacitors C1 and C2 should have the same value. See **Chapter 11 "Reference circuitry"** on page 61 for the capacitance value used for C_{pcb1} and C_{pcb2} in reference circuitry.

3.6.3 32.768 kHz RC oscillator

The 32.768 kHz RC low frequency oscillator may be used as an alternative to the 32.768 kHz crystal oscillator. It has a frequency accuracy of less than ± 250 ppm in a stable temperature environment or when calibration is periodically performed in changing temperature environments. The 32.768 kHz RC oscillator does not require external components.

Note: The ANT protocol stack requires an accuracy of ±50 ppm, thus the 32.768 kHz RC oscillator must not be used when running the ANT stack.

3.6.4 Synthesized 32.768 kHz clock

The low frequency clock can be synthesized from the high frequency clock. This saves the cost of a crystal but increases average power consumption as the high frequency clock source will have to be active.

3.7 GPIO

The general purpose I/O is organized as one port with up to 32 I/Os (dependent on package) enabling access and control of up to 32 pins through one port. Each GPIO can be accessed individually with the following user configurable features:

- Input/output direction
- Output drive strength
- Internal pull-up and pull-down resistors
- Wake-up from high or low level triggers on all pins
- Trigger interrupt on all pins
- All pins can be used by the PPI task/event system; the maximum number of pins that can be interfaced through the PPI at the same time is limited by the number of GPIOTE channels
- All pins can be individually configured to carry serial interface or quadrature demodulator signals

3.8 Debugger support

The two pin Serial Wire Debug (SWD) interface provided as a part of the Debug Access Port (DAP) in conjunction with the Nordic Trace Buffer (NTB) offers a flexible and powerful mechanism for non-intrusive debugging of program code. Breakpoints, single stepping, and instruction trace capture of code execution flow are part of this support.

4 Peripheral blocks

Peripheral blocks which have a register interface and/or interrupt vector assigned are instantiated, one or more times, in the device address space. The instances, associated ID (for those with interrupt vectors), and base address of features are found in **Table 15** on page 29. Detailed functional descriptions, configuration options, and register interfaces can be found in the *nRF51 Series Reference Manual*.

4.1 2.4 GHz radio (RADIO)

The nRF51 series 2.4 GHz RF transceiver is designed and optimized to operate in the worldwide ISM frequency band at 2.400 to 2.4835 GHz. Radio modulation modes and configurable packet structure enable interoperability with *Bluetooth*® low energy (BLE), ANT™, Enhanced ShockBurst™, and other 2.4 GHz protocol implementations.

The transceiver receives and transmits data directly to and from system memory for flexible and efficient packet data management. The nRF51 series transceiver has the following features:

- General modulation features
 - GFSK modulation
 - Data whitening
 - On-air data rates
 - 250 kbps
 - 1 Mbps
 - 2 Mbps
- Transmitter with programmable output power of +4 dBm to -20 dBm, in 4 dB steps
- Transmitter whisper mode -30 dBm
- RSSI function (1 dB resolution)
- Receiver with integrated channel filters achieving maximum sensitivity
 - -96 dBm at 250 kbps
 - -93 dBm at 1 Mbps BLE
 - -90 dBm at 1 Mbps
 - -85 dBm at 2 Mbps
- RF Synthesizer
 - 1 MHz frequency programming resolution
 - 1 MHz non-overlapping channel spacing at 1 Mbps and 250 kbps
 - 2 MHz non-overlapping channel spacing at 2 Mbps
 - Works with low-cost ± 60 ppm 16 MHz crystal oscillators
- Baseband controller
 - EasyDMA RX and TX packet transfer directly to and from RAM
 - Dynamic payload length
 - On-the-fly packet assembly/disassembly and AES CCM payload encryption
 - 8 bit, 16 bit, and 24 bit CRC check (programmable polynomial and initial value)

Note: EasyDMA is an integrated DMA implementation requiring no configuration to take advantage of flexible data management and avoids copying operations to and from RAM.

4.2 Timer/counters (TIMER)

The timer/counter runs on the high-frequency clock source (HFCLK) and includes a 4 bit ($1/2^X$) prescaler that can divide the HFCLK.

The task/event and interrupt features make it possible to use the PPI system for timing and counting tasks between any system peripheral including any GPIO of the device. The PPI system also enables the TIMER task/event features to generate periodic output and PWM signals to any GPIO. The number of input/outputs used at the same time is limited by the number of GPIOTE channels.

| Instance | Bit-width | Capture/Compare registers |
|----------|------------|---------------------------|
| TIMER0 | 8/16/24/32 | 4 |
| TIMER1 | 8/16 | 4 |
| TIMER2 | 8/16 | 4 |

Table 9 Timer/counter properties

4.3 Real Time Counter (RTC)

The Real Time Counter (RTC) module provides a generic, low power timer on the low-frequency clock source (LFCLK). The RTC features a 24 bit COUNTER, 12 bit ($1/X$) prescaler, capture/compare registers, and a tick event generator for low power, tickless RTOS implementation.

| Instance | Capture/Compare registers |
|----------|---------------------------|
| RTC0 | 3 |
| RTC1 | 4 |

Table 10 RTC properties

4.4 AES Electronic Codebook Mode Encryption (ECB)

The ECB encryption block supports 128 bit AES block encryption. It can be used for a range of cryptographic functions like hash generation, digital signatures, and keystream generation for data encryption/decryption. ECB encryption uses EasyDMA to access system RAM for in-place operations on cleartext and ciphertext during encryption.

4.5 AES CCM Mode Encryption (CCM)

Cipher Block Chaining - Message Authentication Code (CCM) Mode is an authenticated encryption algorithm designed to provide both authentication and confidentiality during data transfer. CCM combines counter mode encryption and CBC-MAC authentication.

Note: The CCM terminology "Message Authentication Code (MAC)" is called the "Message Integrity Check (MIC)" in *Bluetooth* terminology and this document and the *nRF51 Series Reference Manual* are consistent with *Bluetooth* terminology.

The CCM block generates an encrypted keystream, applies it to the input data using the XOR operation, and generates the 4 byte MIC field in one operation. The CCM and radio can be configured to work synchronously, as described in the *nRF51 Series Reference Manual*. The CCM will encrypt in time for transmission and decrypt after receiving bytes into memory from the Radio. All operations can complete within the packet RX or TX time.

CCM on this device is implemented according to *Bluetooth* requirements and the algorithm as defined in [IETF RFC3610](#), and depends on the AES-128 block cipher. A description of the CCM algorithm can also be found in the [NIST Special Publication 800-38C](#). The *Bluetooth* Core Specification v4.0 describes the configuration of counter mode blocks and encryption blocks to implement compliant encryption for BLE.

The CCM block uses EasyDMA to load key, counter mode blocks (including the nonce required), and to read/write plain text and cipher text.

4.6 Accelerated Address Resolver (AAR)

Accelerated Address Resolver is a cryptographic support function to implement the "Resolvable Private Address Resolution Procedure" described in the *Bluetooth Core Specification* v4.1. "Resolvable Private Address Generation" should be achieved using ECB and is not supported by AAR. The procedure allows two devices that share a secret key to generate and resolve a hash based on their device address.

The AAR block enables real-time address resolution on incoming packets when configured according to the description in the *nRF51 Series Reference Manual*. This allows real-time packet filtering (whitelisting) using a list of known shared secrets (Identity Resolving Keys (IRK) in *Bluetooth*).

The following table outlines the properties of the AAR.

| Instance | Number of IRKs supported for simultaneous resolution |
|----------|--|
| AAR | 8 |

Table 11 AAR properties

4.7 Random Number Generator (RNG)

The Random Number Generator (RNG) generates true non-deterministic random numbers derived from thermal noise that are suitable for cryptographic purposes. The RNG does not require a seed value.

4.8 Watchdog Timer (WDT)

A countdown watchdog timer using the low-frequency clock source (LFCLK) offers configurable and robust protection against application lock-up. The watchdog can be paused during long CPU sleep periods for low power applications and when the debugger has halted the CPU.

4.9 Temperature sensor (TEMP)

The temperature sensor measures die temperature over the temperature range of the device with 0.25° C resolution.

4.10 Serial Peripheral Interface (SPI/SPIS)

The SPI interfaces enable full duplex synchronous communication between devices. They support a three-wire (SCK, MISO, MOSI) bi-directional bus with fast data transfers. The SPI Master can communicate with multiple slaves using individual chip select signals for each of the slave devices attached to a bus. Control of chip select signals is left to the application through use of GPIO signals. SPI Master has double buffered I/O data. The SPI Slave includes EasyDMA for data transfer directly to and from RAM allowing Slave data transfers to occur while the CPU is IDLE.

The GPIOs used for each SPI interface line can be chosen from any GPIO on the device and are independently configurable. This enables great flexibility in device pinout and efficient use of printed circuit board space and signal routing.

The SPI peripheral supports SPI mode 0, 1, 2, and 3.

| Instance | Master/Slave |
|----------|--------------|
| SPI0 | Master |
| SPI1 | Master |
| SPIS1 | Slave |

Table 12 SPI properties

4.11 Two-wire interface (TWI)

The two-wire interface can communicate with a bi-directional wired-AND bus with two lines (SCL, SDA). The protocol makes it possible to interconnect up to 127 individually addressable devices. The interface is capable of clock stretching, supporting data rates of 100 kbps and 400 kbps.

The GPIOs used for each two-wire interface line can be chosen from any GPIO on the device and are independently configurable. This enables great flexibility in device pinout and efficient use of board space and signal routing.

| Instance | Master/Slave |
|----------|--------------|
| TWI0 | Master |
| TWI1 | Master |

Table 13 Two-wire properties

4.12 Universal Asynchronous Receiver/Transmitter (UART)

The Universal Asynchronous Receiver/Transmitter offers fast, full-duplex, asynchronous serial communication with built-in flow control (CTS, RTS) support in hardware up to 1 Mbps baud. Parity checking is supported.

The GPIOs used for each UART interface line can be chosen from any GPIO on the device and are independently configurable. This enables great flexibility in device pinout and efficient use of board space and signal routing.

4.13 Quadrature Decoder (QDEC)

The quadrature decoder provides buffered decoding of quadrature-encoded sensor signals. It is suitable for mechanical and optical sensors with an optional LED output signal and input debounce filters. The sample period and accumulation are configurable to match application requirements.

4.14 Analog to Digital Converter (ADC)

The 10 bit incremental Analog to Digital Converter (ADC) enables sampling of up to 8 external signals through a front-end multiplexer. The ADC has configurable input and reference prescaling, and sample resolution (8, 9, and 10 bit).

Note: The ADC module uses the same analog inputs as the LPCOMP module (AIN0 - AIN7 and AREF0 - AREF1). Only one of the modules can be enabled at the same time.

4.15 GPIO Task Event blocks (GPIOTE)

A GPIOTE block enables GPIOs on Port 0 to generate events on pin state change which can be used to carry out tasks through the PPI system. A GPIO can also be driven to change state on system events using the PPI system. Low power detection of pin state changes on Port 0 is possible when in System ON or System OFF.

| Instance | Number of GPIOTE channels |
|----------|---------------------------|
| GPIOTE | 4 |

Table 14 GPIOTE properties

4.16 Low Power Comparator (LPCOMP)

In System ON, the block can generate separate events on rising and falling edges of a signal, or sample the current state of the pin as being above or below the threshold. The block can be configured to use any of the analog inputs on the device. Additionally, the low power comparator can be used as an analog wakeup source from System OFF or System ON. The comparator threshold can be programmed to a range of fractions of the supply voltage.

Note: The LPCOMP module uses the same analog inputs as the ADC module (AIN0 - AIN7 and AREF0 - AREF1). Only one of the modules can be enabled at the same time.

5 Instance table

The peripheral instantiation of the chip is shown in the table below.

| ID | Base address | Peripheral | Instance | Description |
|---------|--------------|------------|----------|--|
| 0 | 0x40000000 | POWER | POWER | Power Control. |
| 0 | 0x40000000 | CLOCK | CLOCK | Clock Control. |
| 1 | 0x40001000 | RADIO | RADIO | 2.4 GHz Radio. |
| 2 | 0x40002000 | UART | UART0 | Universal Asynchronous Receiver/Transmitter. |
| 3 | 0x40003000 | SPI | SPI0 | SPI Master. |
| 3 | 0x40003000 | TWI | TWI0 | I2C compatible Two-Wire Interface 0. |
| 4 | 0x40004000 | SPIS | SPIS1 | SPI Slave. |
| 4 | 0x40004000 | SPI | SPI1 | SPI Master. |
| 4 | 0x40004000 | TWI | TWI1 | I2C compatible Two-Wire Interface 1. |
| 5 | | | | Unused. |
| 6 | 0x40006000 | GPIOTE | GPIOTE | GPIO Task and Events. |
| 7 | 0x40007000 | ADC | ADC | Analog to Digital Converter. |
| 8 | 0x40008000 | TIMER | TIMER0 | Timer/Counter 0. |
| 9 | 0x40009000 | TIMER | TIMER1 | Timer/Counter 1. |
| 10 | 0x4000A000 | TIMER | TIMER2 | Timer/Counter 2. |
| 11 | 0x4000B000 | RTC | RTC0 | Real Time Counter 0. |
| 12 | 0x4000C000 | TEMP | TEMP | Temperature Sensor. |
| 13 | 0x4000D000 | RNG | RNG | Random Number Generator. |
| 14 | 0x4000E000 | ECB | ECB | Crypto AES ECB. |
| 15 | 0x4000F000 | CCM | CCM | AES Crypto CCM. |
| 15 | 0x4000F000 | AAR | AAR | Accelerated Address Resolver. |
| 15 | 0x4000F000 | | | Unused. |
| 16 | 0x40010000 | WDT | WDT | Watchdog Timer. |
| 17 | 0x40011000 | RTC | RTC1 | Real Time Counter 1. |
| 18 | 0x40012000 | QDEC | QDEC | Quadrature Decoder. |
| 19 | 0x40013000 | LPCOMP | LPCOMP | Low Power Comparator. |
| 20 - 25 | | | | Reserved as software interrupt. |
| 26 - 29 | | | | Unused. |
| 30 | 0x4001E000 | NVMC | NVMC | Non-Volatile Memory Controller. |
| 31 | 0x4001F000 | PPI | PPI | Programmable Peripheral Interconnect. |
| NA | 0x50000000 | GPIO | GPIO | General Purpose Input and Output. |
| NA | 0x10000000 | FICR | FICR | Factory Information Configuration Registers. |
| NA | 0x10001000 | UICR | UICR | User Information Configuration Registers. |

Table 15 Peripheral instance reference

6 Absolute maximum ratings

Maximum ratings are the extreme limits the chip can be exposed to without causing permanent damage. Exposure to absolute maximum ratings for prolonged periods of time may affect the reliability of the chip. *Table 16* specifies the absolute maximum ratings.

| Symbol | Parameter | Min. | Max. | Unit |
|--|----------------------------|---------------------|-----------|--------------------|
| Supply voltages | | | | |
| VDD | | -0.3 | +3.9 | V |
| DEC2 | | | 2 | V |
| VSS | | | 0 | V |
| I/O pin voltage | | | | |
| VIO | | -0.3 | VDD + 0.3 | V |
| Environmental QFN48 package | | | | |
| Storage temperature | | -40 | +125 | °C |
| MSL | Moisture Sensitivity Level | | 2 | |
| ESD HBM | Human Body Model | | 4 | kV |
| ESD CDM | Charged Device Model | | 750 | V |
| Environmental WLCSP package | | | | |
| Storage temperature | | -40 | +125 | °C |
| MSL | Moisture Sensitivity Level | | 1 | |
| ESD HBM | Human Body Model | | 4 | kV |
| ESD CDM | Charged Device Model | | 500 | V |
| Flash memory | | | | |
| Endurance | | 20 000 ¹ | | write/erase cycles |
| Retention | | 10 years at 40 °C | | |
| Number of times an address can be written between erase cycles | | | 2 | times |

- Flash endurance is 20,000 erase cycles. The smallest element of flash that can be written is a 32 bit word.

Table 16 Absolute maximum ratings



7 Operating conditions

The operating conditions are the physical parameters that the chip can operate within as defined in *Table 17*.

| Symbol | Parameter | Notes | Min. | Typ. | Max. | Units |
|--------------------|---|-------|------|------|------|-------|
| VDD | Supply voltage, normal mode | | 1.8 | 3.0 | 3.6 | V |
| VDD | Supply voltage, normal mode, DC/DC converter output voltage 1.9 V | | 2.1 | 3.0 | 3.6 | V |
| VDD | Supply voltage, low voltage mode | 1 | 1.75 | 1.8 | 1.95 | V |
| t _{R_VDD} | Supply rise time (0 V to 1.8 V) | 2 | | | 60 | ms |
| T _A | Operating temperature | | -25 | 25 | 75 | °C |

1. DEC2 shall be connected to VDD in this mode.
2. The on-chip power-on reset circuitry may not function properly for rise times outside the specified interval.

Table 17 Operating conditions

Nominal operating conditions (NOC) - conditions under which the chip is operated and tested are the typical (Typ.) values in *Table 17*.

Extreme operating conditions (EOC) - conditions under which the chip is operated and tested are the minimum (Min.) and maximum (Max.) values in *Table 17*.

7.1 WLCSP light sensitivity

The WLCSP package variant is sensitive to visible and near infrared light which means a final product design must shield the chip properly. The marking side is covered with a light absorbing film, while the side edges of the chip and the ball side must be protected by coating or other means.

8 Electrical specifications

This chapter contains electrical specifications for device interfaces and peripherals including radio parameters and current consumption.

The test levels referenced are defined in *Table 18*.

| Test level | Description |
|------------|---|
| 1 | Simulated, calculated, by design (specification limit) or prototype samples tested at NOC. |
| 2 | Parameters have been verified at Test level 1 and in addition: Prototype samples tested at EOC. |
| 3 | Parameters have been verified at Test level 2 and in addition: Production samples tested at EOC in accordance with JEDEC47. |
| 4 | Parameters have been verified at Test level 3 and in addition: Production devices are limit tested at NOC. |

Table 18 Test level definitions

8.1 Clock sources

8.1.1 16/32 MHz crystal startup

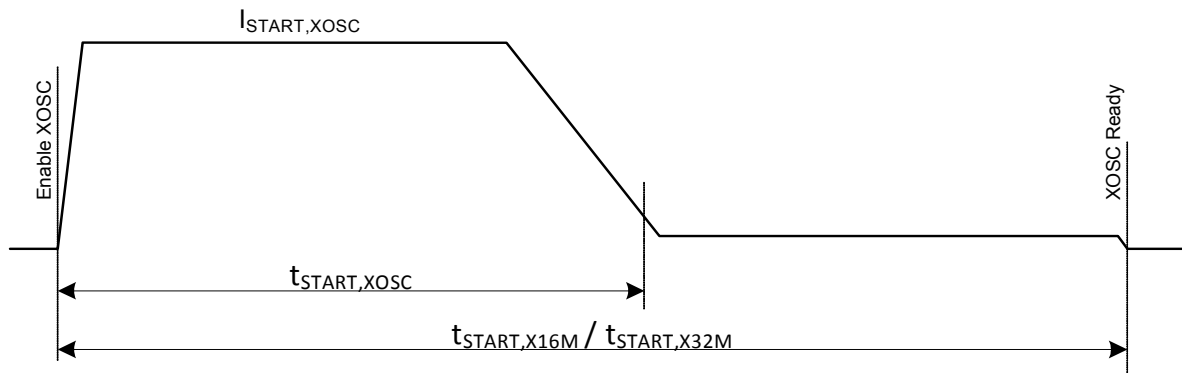

Figure 8 Current drawn at oscillator startup

Figure 8 shows the current drawn by the crystal oscillator (XOSC) at startup. The $t_{START,XOSC}$ period is the time needed for the oscillator to start clocking. The length of $t_{START,XOSC}$ is dependent on the crystal specifications.

The period following $t_{START,XOSC}$ to the end of $t_{START,X16M} / t_{START,X32M}$ is fixed. This is the debounce period where the clock stabilizes before it is made available to rest of the system.

8.1.2 16 MHz crystal oscillator (16M XOSC)

| Symbol | Description | Note | Min. | Typ. | Max. | Units | Test level |
|---------------------------|---|---|------|------------------|------------------|---------------|------------|
| $f_{\text{NOM},X16M}$ | Crystal frequency. | | | 16 | | MHz | N/A |
| $f_{\text{TOL},X16M,ANT}$ | Frequency tolerance, ANT. ¹ | | | | $\pm 50^2$ | ppm | N/A |
| $f_{\text{TOL},X16M,BLE}$ | Frequency tolerance, <i>Bluetooth</i> low energy applications. ¹ | | | | $\pm 40^2$ | ppm | N/A |
| $R_{\text{S},X16M}$ | Equivalent series resistance. | $C_0 \leq 7 \text{ pF}, C_{\text{L},\text{MAX}} \leq 16 \text{ pF}$ | | 50 | 100 | Ω | N/A |
| | | $C_0 \leq 5 \text{ pF}, C_{\text{L},\text{MAX}} \leq 12 \text{ pF}$ | | 75 | 150 | Ω | N/A |
| | | $C_0 \leq 3 \text{ pF}, C_{\text{L},\text{MAX}} \leq 12 \text{ pF}$ | | 100 | 200 | Ω | N/A |
| $P_{\text{D},X16M}$ | Drive level. | | | | 100 | μW | N/A |
| C_{pin} | Input capacitance on XC1 and XC2 pads. | | | 4 | | pF | 1 |
| I_{X16M} | Run current for 16 MHz crystal oscillator. | SMD 2520 CL = 8 pF | | 470 ³ | | μA | 1 |
| $I_{\text{STBY},X16M}$ | Standby current for 16 MHz crystal oscillator. ⁴ | SMD 2520 CL = 8 pF | | 25 | | μA | 1 |
| $I_{\text{START},XOSC}$ | Startup current for 16 MHz crystal oscillator. | | | 1.1 | | mA | 3 |
| $t_{\text{START},XOSC}$ | Startup time for 16 MHz crystal oscillator. | SMD 2520 CL = 8 pF | | 400 | 500 ⁵ | μs | 2 |
| $t_{\text{START},X16M}$ | Total startup time ($t_{\text{START},XOSC}$ + debounce period). ⁶ | SMD 2520 CL = 8 pF | | 800 | | μs | 1 |

1. The Frequency tolerance relates to the amount of time the radio can be in transmit mode. See **Table 32** on page 41.
2. Includes initial tolerance of the crystal, drift over temperature, aging, and frequency pulling due to incorrect load capacitance.
3. This number includes the current used by the automated power and clock management system.
4. Standby current is the current drawn by the oscillator when there are no resources requesting the 16M, meaning there is no clock management active (see **Table 28** on page 39). This value will depend on type of crystal.
5. Crystals with other specification than SMD 2520 may have much longer startup times.
6. This is the time from when the crystal oscillator is powered up until its output becomes available to the system. It includes both the crystal startup time and the debounce period.

Table 19 16 MHz crystal oscillator

8.1.3 32 MHz crystal oscillator (32M XOSC)

| Symbol | Description | Note | Min. | Typ. | Max. | Units | Test level |
|---|--|---|------|------------------|------------------|---------------|------------|
| $f_{\text{NOM},\text{X32M}}$ | Crystal frequency. | | | 32 | | MHz | N/A |
| $f_{\text{TOL},\text{X32M},\text{ANT}}$ | Frequency tolerance, ANT. ¹ | | | | $\pm 50^2$ | ppm | N/A |
| $f_{\text{TOL},\text{X32M},\text{BLE}}$ | Frequency tolerance, <i>Bluetooth</i> low energy applications. ¹ | | | | $\pm 40^2$ | ppm | N/A |
| $R_{\text{S},\text{X32M}}$ | Equivalent series resistance. | $C_0 \leq 7 \text{ pF}, C_{\text{L},\text{MAX}} \leq 12 \text{ pF}$ | | 30 | 60 | Ω | N/A |
| | | $C_0 \leq 5 \text{ pF}, C_{\text{L},\text{MAX}} \leq 12 \text{ pF}$ | | 40 | 80 | Ω | N/A |
| | | $C_0 \leq 3 \text{ pF}, C_{\text{L},\text{MAX}} \leq 9 \text{ pF}$ | | 50 | 100 | Ω | N/A |
| $P_{\text{D},\text{X32M}}$ | Drive level. | | | | 100 | μW | N/A |
| C_{pin} | Input capacitance on XC1 and XC2 pads. | | | 4 | | pF | 1 |
| I_{X32M} | Run current for 32 MHz crystal oscillator. | SMD 2520 CL = 8 pF | | 500 ³ | | μA | 1 |
| $I_{\text{STBY},\text{X32M}}$ | Standby current for 32 MHz crystal oscillator. ⁴ | SMD 2520 CL = 8 pF | | 30 | | μA | 1 |
| $I_{\text{START},\text{XOSC}}$ | Startup current for 32 MHz crystal oscillator. | | | 1.1 | | mA | 3 |
| $t_{\text{START},\text{XOSC}}$ | Startup time for 32 MHz crystal oscillator. | SMD 2520 CL = 8 pF | | 300 | 400 ⁵ | μs | 1 |
| $t_{\text{START},\text{X32M}}$ | Total startup time ($t_{\text{START},\text{XOSC}}$ + debounce period). ⁶ | SMD 2520 CL = 8 pF | | 750 | | μs | 1 |

1. The Frequency tolerance relates to the amount of time the radio can be in transmit mode. See **Table 32** on page 41.
2. Includes initial tolerance of the crystal, drift over temperature, aging and frequency pulling due to incorrect load capacitance.
3. This number includes the current used by the automated power and clock management system.
4. Standby current is the current drawn by the oscillator when there are no resources requesting the 32M, meaning there is no clock management active (see **Table 28** on page 39). This value will depend on type of crystal.
5. Crystals with other specification than SMD 2520 may have much longer startup times.
6. This is the time from when the crystal oscillator is powered up until its output becomes available to the system. It includes both the crystal startup time and the debounce period.

Table 20 32 MHz crystal oscillator

8.1.4 16 MHz RC oscillator (16M RCOSC)

| Symbol | Description | Min. | Typ. | Max. | Units | Test level |
|---------------------------|---|------|------------------|---------|---------------|------------|
| $f_{\text{NOM,RC16M}}$ | Nominal frequency. | | 16 | | MHz | N/A |
| $f_{\text{TOL,RC16M}}$ | Frequency tolerance. | | ± 1 | ± 5 | % | 3 |
| I_{RC16M} | Run current for 16 MHz RC oscillator. | | 750 ¹ | | μA | 1 |
| $t_{\text{START,RC16M}}$ | Startup time for 16 MHz RC oscillator. | | 2.5 | 3.5 | μs | 1 |
| $I_{\text{RC16M, START}}$ | Startup current for 16 MHz RC oscillator. | | 400 | | μA | 1 |

1. This number includes the current used by the automated power and clock management system.

Table 21 16 MHz RC oscillator

8.1.5 32.768 kHz crystal oscillator (32k XOSC)

| Symbol | Description | Min. | Typ. | Max. | Units | Test level |
|---------------------------|--|------|--------|-----------|------------------|------------|
| $f_{\text{NOM,X32k}}$ | Crystal frequency. | | 32.768 | | kHz | N/A |
| $f_{\text{TOL,X32k,BLE}}$ | Frequency tolerance, <i>Bluetooth</i> low energy applications. | | | ± 250 | ppm | N/A |
| $f_{\text{TOL,X32k,ANT}}$ | Frequency tolerance, ANT applications. | | | ± 50 | ppm | N/A |
| $C_{\text{L,X32k}}$ | Load capacitance. | | | 12.5 | pF | N/A |
| $C_{\text{0,X32k}}$ | Shunt capacitance. | | | 2 | pF | N/A |
| $R_{\text{S,X32k}}$ | Equivalent series resistance. | | 50 | 80 | $\text{k}\Omega$ | N/A |
| $P_{\text{D,X32k}}$ | Drive level. | | | 1 | μW | N/A |
| C_{pin} | Input capacitance on XL1 and XL2 pads. | | 4 | | pF | 1 |
| I_{X32k} | Run current for 32.768 kHz crystal oscillator. | | 0.4 | 1 | μA | 1 |
| $I_{\text{START,X32k}}$ | Startup current for 32.768 kHz crystal oscillator. | | 1.3 | 1.8 | μA | 1 |
| $t_{\text{START,X32k}}$ | Startup time for 32.768 kHz crystal oscillator. | | 0.3 | 1 | s | 2 |

Table 22 32.768 kHz crystal oscillator

8.1.6 32.768 kHz RC oscillator (32k RCOSC)

| Symbol | Description | Note | Min. | Typ. | Max. | Units | Test level |
|----------------------------|----------------------|--------------------------|------|---------|-----------|---------------|------------|
| $f_{\text{NOM,RC32k}}$ | Nominal frequency. | | | 32.768 | | kHz | N/A |
| $f_{\text{TOL,RC32k}}$ | Frequency tolerance. | | | ± 2 | | % | 3 |
| $f_{\text{TOL,CAL,RC32k}}$ | Frequency tolerance. | Calibration interval 4 s | | | ± 250 | ppm | 1 |
| I_{RC32k} | Run current. | | 0.5 | 0.8 | 1.1 | μA | 1 |
| $t_{\text{START,RC32k}}$ | Startup time. | | | 100 | | μs | 1 |

Table 23 32.768 kHz RC oscillator

Note: The ANT protocol stack requires an accuracy of ± 50 ppm, thus the 32.768 kHz RC oscillator must not be used when running the ANT stack.

8.1.7 32.768 kHz Synthesized oscillator (32k SYNT)

| Symbol | Description | Note | Min. | Typ. | Max. | Units | Test level |
|----------------------------|--|--|------|--|------|---------------|------------|
| $f_{\text{NOM,SYNT32k}}$ | Nominal frequency. | | | 32.768 | | kHz | 1 |
| $f_{\text{TOL,SYNT}}$ | Frequency tolerance. | The ANT protocol stack requires an accuracy of ± 50 ppm on the 32.768 kHz clock. | | $f_{\text{TOL,XO16M}} \pm 8$ $f_{\text{TOL,XO32M}} \pm 8$ | | ppm | 1 |
| I_{SYNT32k} | Run and startup current for 32.768 kHz Synthesized clock including the 16M XOSC. | | | 15 | | μA | 1 |
| $t_{\text{START,SYNT32k}}$ | Startup time for 32.768 kHz Synthesized clock. | | | 100 | | μs | 1 |

Table 24 32.768 kHz Synthesized oscillator

8.2 Power management

| Symbol | Description | Note | Min. | Typ. | Max. | Units | Test level |
|------------|--|----------------------------------|------|--------------------------|------|-------|------------|
| V_{POF} | Nominal power level warning thresholds (falling supply voltage). | Accuracy as defined by V_{TOL} | | 2.1 2.3 2.5 2.7 | | V | 2 |
| V_{TOL} | Threshold voltage tolerance. | | | | ±5 | % | 3 |
| V_{HYST} | Threshold voltage hysteresis. | 2.1 V 2.3 V 2.5 V 2.7 V | | 46 62 79 100 | | mV | 3 |

Table 25 Power Fail Comparator

| Symbol | Description | Min. | Typ. | Max. | Units | Test level |
|-----------------------|---|------|------|------|-------|------------|
| $t_{HOLDRESETNORMAL}$ | Hold time for reset pin when doing a pin reset. ¹ | 0.2 | | | μs | 1 |
| $t_{HOLDRESETDEBUG}$ | Hold time for reset pin when doing a pin reset during debug. ^{1,2} | 100 | | | μs | 1 |

1. SWDCLK pin must be kept low during reset.
2. Bit 0 in the RESET register in the power management module must be set to 1 to enable reset during debug.

Table 26 Pin Reset

| Symbol | Description | Note | Min. | Typ. | Max. | Units | Test level |
|-------------------|--|---------------------------------|-------------------|------------------|------------------|---------|------------|
| $t_{POR, 1\mu s}$ | Time Reset is active from VDD reaches 1.7 V with 1 μs rise time. | | 0.2 | 2.7 | | ms | 1 |
| $t_{POR, 50 ms}$ | Time Reset is active from VDD reaches 1.7 V with 50 ms rise time. | | 6.5 | 29 | | ms | 1 |
| I_{OFF} | Current in SYSTEM OFF, no RAM retention. | | | 0.6 ¹ | | μA | 2 |
| $I_{OFF, 8 k}$ | Current in SYSTEM OFF mode 8 kB SRAM retention. | | | 1.2 ¹ | | μA | 2 |
| $I_{OFF, 16 k}$ | Current in SYSTEM OFF mode 16 kB SRAM retention. | | | 1.8 ¹ | | μA | 2 |
| I_{OFF2ON} | OFF to CPU execute transition current. | | | 400 | | μA | 1 |
| t_{OFF2ON} | OFF to CPU execute. | | | 9.6 | 10.6 | μs | 1 |
| I_{ON} | SYSTEM-ON base current with 16 kB RAM enabled. | | | 2.6 ¹ | | μA | 2 |
| t_{1V2} | Startup time for 1V2 regulator. | | | 2.3 | | μs | 1 |
| $I_{1V2RC16}$ | Current drawn by 1V2 regulator and 16 MHz RCOSC when both are on at the same time. | See Table 28 on page 39. | | 880 ² | | μA | 1 |
| $I_{1V2XO16}$ | Current drawn by 1V2 regulator and 16 MHz XOOSC when both are on at the same time. | See Table 28 on page 39. | | 810 ² | | μA | 1 |
| $I_{1V2XO32}$ | Current drawn by 1V2 regulator and 32 MHz XOOSC when both are on at the same time. | See Table 28 on page 39. | | 840 ² | | μA | 1 |
| t_{1V7} | Startup time for 1V7 regulator | | | 2 | 3.6 | μs | 1 |
| I_{1V7} | Current drawn by 1V7 regulator | | | 105 | | μA | 2 |
| I_{DCDC} | Current drawn by DC/DC converter. | | | 300 | | μA | 1 |
| F_{DCDC} | DC/DC converter current conversion factor. | | 0.65 ³ | | 1.2 ³ | | 1 |
| $t_{START,DCDC}$ | DC/DC converter startup time. | | 10 ³ | | 425 ³ | μs | 1 |

1. Add 1 μA to the current value if the device is used in Low voltage mode.
2. This number includes the current used by the automated power and clock management system.
3. F_{DCDC} and $t_{START,DCDC}$ will vary depending on VDD and device internal current consumption (I_{DD}). The range of values stated in this specification is for VDD between 2.1 V and 3.6 V, and I_{DD} between 4 mA and 20 mA. Please refer to the *nRF51 Series Reference Manual*, v1.1 or later, for a method to calculate these numbers based on VDD and I_{DD} .

Table 27 Power management

8.3 Block resource requirements

| Block | ID | Required resources | | | Comment |
|--------|----------|------------------------|--------------------|-----|---|
| | | 1V2+HFCLK ¹ | HFCLK ¹ | 32k | |
| Radio | 1 | x | | | Requires 16M/32M XOSC. |
| UART | 2 | x | | | When UART receiver or transmitter are STARTed. |
| SPIS | 4 | x | | | Requested when CSN asserted. |
| SPI | 3, 4 | x | | | |
| TWI | 3, 4 | x | | | |
| GPIOTE | 6 | x | | | Only in input mode. |
| ADC | 7 | x | | | Requires 16M/32M XOSC. |
| TIMER | 8, 9, 10 | | x | | |
| RTC | 11, 17 | | | x | 16M/32M will only be requested if the 32.768 kHz clock is synthesized from the 16/32 MHz clock. |
| TEMP | 12 | x | | | Requires 16M/32M XOSC. |
| RNG | 13 | x | | | |
| ECB | 14 | x | | | |
| WDT | 16 | | | x | |
| QDEC | 18 | x | | | |
| LPCOMP | 19 | | | | No resources required. |

1. HFCLK is the selected 16 MHz or 32 MHz clock source.

Table 28 Clock and power requirements for different blocks

8.4 CPU

| Symbol | Description | Min. | Typ. | Max. | Units | Test level |
|-------------------------|---|----------------|------------------|------|---------------|------------|
| $I_{\text{CPU, Flash}}$ | Run current at 16 MHz. Executing code from flash memory. | | 4.4 ¹ | | mA | 2 |
| $I_{\text{CPU, RAM}}$ | Run current at 16 MHz. Executing code from RAM. | | 2.4 ² | | mA | 1 |
| $I_{\text{START, CPU}}$ | CPU startup current. | | 600 | | μA | 1 |
| $t_{\text{START, CPU}}$ | IDLE to CPU execute. | 0 ³ | | | μs | 1 |

1. Includes CPU, flash, 1V2, 1V7, RC16M.
2. Includes CPU, RAM, 1V2, RC16M.
3. t_{1V2} if 1V2 regulator is not running already.

Table 29 CPU specifications

8.5 Radio transceiver

8.5.1 General radio characteristics

| Symbol | Description | Note | Min. | Typ. | Max. | Units | Test level |
|------------------|----------------------------------|------------------------|-----------|-----------|-----------|-------|------------|
| f_{OP} | Operating frequencies. | 1 MHz channel spacing. | 2400 | | 2483 | MHz | N/A |
| PLL_{res} | PLL programming resolution. | | | 1 | | MHz | N/A |
| Δf_{250} | Frequency deviation at 250 kbps. | | | ± 170 | | kHz | 2 |
| Δf_{1M} | Frequency deviation at 1 Mbps. | | | ± 170 | | kHz | 2 |
| Δf_{2M} | Frequency deviation at 2 Mbps. | | | ± 320 | | kHz | 2 |
| Δf_{BLE} | Frequency deviation at BLE. | | ± 225 | ± 250 | ± 275 | kHz | 4 |
| bps_{FSK} | On-air data rate. | | 250 | | 2000 | kbps | N/A |

Table 30 General radio characteristics

8.5.2 Radio current consumption

| Symbol | Description | Note | Min. | Typ. | Max. | Units | Test level |
|-----------------|---|------|------|------|------|-------|------------|
| $I_{TX,+4dBm}$ | TX only run current at $P_{OUT} = +4$ dBm. | 1 | | 16 | | mA | 4 |
| $I_{TX,0dBm}$ | TX only run current at $P_{OUT} = 0$ dBm. | 1 | | 10.5 | | mA | 4 |
| $I_{TX,-4dBm}$ | TX only run current at $P_{OUT} = -4$ dBm. | 1 | | 8 | | mA | 2 |
| $I_{TX,-8dBm}$ | TX only run current at $P_{OUT} = -8$ dBm. | 1 | | 7 | | mA | 2 |
| $I_{TX,-12dBm}$ | TX only run current at $P_{OUT} = -12$ dBm. | 1 | | 6.5 | | mA | 2 |
| $I_{TX,-16dBm}$ | TX only run current at $P_{OUT} = -16$ dBm. | 1 | | 6 | | mA | 2 |
| $I_{TX,-20dBm}$ | TX only run current at $P_{OUT} = -20$ dBm. | 1 | | 5.5 | | mA | 2 |
| $I_{TX,-30dBm}$ | TX only run current at $P_{OUT} = -30$ dBm. | 1 | | 5.5 | | mA | 2 |
| $I_{START,TX}$ | TX startup current. | 2 | | 7 | | mA | 1 |
| $I_{RX,250}$ | RX only run current at 250 kbps. | | | 12.6 | | mA | 1 |
| $I_{RX,1M}$ | RX only run current at 1 Mbps. | | | 13 | | mA | 4 |
| $I_{RX,2M}$ | RX only run current at 2 Mbps. | | | 13.4 | | mA | 1 |
| $I_{START,RX}$ | RX startup current. | 3 | | 8.7 | | mA | 1 |

- Valid for data rates 250 kbps, 1 Mbps, and 2 Mbps.
- Average current consumption (at 0 dBm TX output power) for TX startup (130 μ s), and when changing mode from RX to TX (130 μ s).
- Average current consumption for RX startup (130 μ s), and when changing mode from TX to RX (130 μ s).

Table 31 Radio current consumption

8.5.3 Transmitter specifications

| Symbol | Description | Min. | Typ. | Max. | Units | Test level |
|---------------|---|------|------|---------|-------|------------|
| P_{RF} | Maximum output power. | | 4 | | dBm | 4 |
| P_{RFC} | RF power control range. | 20 | 24 | | dB | 2 |
| PRFCR | RF power accuracy. | | | ± 4 | dB | 1 |
| P_{WHISP} | RF power whisper mode. | | -30 | | dBm | 2 |
| P_{BW2} | 20 dB bandwidth for modulated carrier (2 Mbps). | | 1800 | 2000 | kHz | 2 |
| P_{BW1} | 20 dB bandwidth for modulated carrier (1 Mbps). | | 950 | 1100 | kHz | 2 |
| P_{BW250} | 20 dB bandwidth for modulated carrier (250 kbps). | | 700 | 800 | kHz | 2 |
| $P_{RF1.2}$ | 1 st Adjacent Channel Transmit Power. ± 2 MHz (2 Mbps). | | | -20 | dBc | 2 |
| $P_{RF2.2}$ | 2 nd Adjacent Channel Transmit Power. ± 4 MHz (2 Mbps). | | | -45 | dBc | 2 |
| $P_{RF1.1}$ | 1 st Adjacent Channel Transmit Power. ± 1 MHz (1 Mbps). | | | -20 | dBc | 2 |
| $P_{RF2.1}$ | 2 nd Adjacent Channel Transmit Power. ± 2 MHz (1 Mbps). | | | -40 | dBc | 2 |
| $P_{RF1.250}$ | 1 st Adjacent Channel Transmit Power. ± 1 MHz (250 kbps). | | | -25 | dBc | 2 |
| $P_{RF2.250}$ | 2 nd Adjacent Channel Transmit Power. ± 2 MHz (250 kbps). | | | -40 | dBc | 2 |
| $t_{TX,30}$ | Maximum consecutive transmission time, $f_{TOL} < \pm 30$ ppm. | | | 16 | ms | 1 |
| $t_{TX,60}$ | Maximum consecutive transmission time, $f_{TOL} < \pm 60$ ppm. | | | 4 | ms | 1 |

Table 32 Transmitter specifications

8.5.4 Receiver specifications

| Symbol | Description | Min. | Typ. | Max. | Units | Test level |
|--|--|------|------|------|-------|------------|
| Receiver operation | | | | | | |
| PRX _{MAX} | Maximum received signal strength at < 0.1% PER. | | 0 | | dBm | 1 |
| PRX _{SENS,2M} | Sensitivity (0.1% BER) at 2 Mbps. | | -85 | | dBm | 2 |
| PRX _{SENS,1M} | Sensitivity (0.1% BER) at 1 Mbps. | | -90 | | dBm | 2 |
| PRX _{SENS,250k} | Sensitivity (0.1% BER) at 250 kbps. | | -96 | | dBm | 2 |
| P _{SENS IT} 1 Mbps BLE | Receiver sensitivity: Ideal transmitter. | | -93 | | dBm | 2 |
| P _{SENS DT} 1 Mbps BLE | Receiver sensitivity: Dirty transmitter. ¹ | | -91 | | dBm | 2 |
| RX selectivity - modulated interfering signal² | | | | | | |
| 2 Mbps | | | | | | |
| C/I _{CO} | C/I co-channel. | | 12 | | dB | 2 |
| C/I _{1ST} | 1 st ACS, C/I 2 MHz. | | -4 | | dB | 2 |
| C/I _{2ND} | 2 nd ACS, C/I 4 MHz. | | -24 | | dB | 2 |
| C/I _{3RD} | 3 rd ACS, C/I 6 MHz. | | -28 | | dB | 2 |
| C/I _{6th} | 6 th ACS, C/I 12 MHz. | | -44 | | dB | 2 |
| C/I _{Nth} | N th ACS, C/I f _i > 25 MHz. | | -50 | | dB | 2 |
| 1 Mbps/ANT | | | | | | |
| C/I _{CO} | C/I co-channel (1 Mbps). | | 12 | | dB | 2 |
| C/I _{1ST} | 1 st ACS, C/I 1 MHz. | | 4 | | dB | 2 |
| C/I _{2ND} | 2 nd ACS, C/I 2 MHz. | | -24 | | dB | 2 |
| C/I _{3RD} | 3 rd ACS, C/I 3 MHz. | | -30 | | dB | 2 |
| C/I _{6th} | 6 th ACS, C/I 6 MHz. | | -40 | | dB | 2 |
| C/I _{12th} | 12 th ACS, C/I 12 MHz. | | -50 | | dB | 2 |
| C/I _{Nth} | N th ACS, C/I f _i > 25 MHz. | | -53 | | dB | 2 |

| Symbol | Description | Min. | Typ. | Max. | Units | Test level |
|--|--|------|------|------|-------|------------|
| 250 kbps | | | | | | |
| C/I_{CO} | C/I co-channel. | | 4 | | dB | 2 |
| C/I_{1ST} | 1 st ACS, C/I 1 MHz. | | -10 | | dB | 2 |
| C/I_{2ND} | 2 nd ACS, C/I 2 MHz. | | -34 | | dB | 2 |
| C/I_{3RD} | 3 rd ACS, C/I 3 MHz. | | -39 | | dB | 2 |
| C/I_{6th} | 6 th ACS, C/I $f_i > 6$ MHz. | | -50 | | dB | 2 |
| C/I_{12th} | 12 th ACS, C/I 12 MHz. | | -55 | | dB | 2 |
| C/I_{Nth} | N th ACS, C/I $f_i > 25$ MHz. | | -60 | | dB | 2 |
| Bluetooth Low Energy RX selectivity | | | | | | |
| C/I_{CO} | C/I co-channel. | | 10 | | dB | 2 |
| C/I_{1ST} | 1 st ACS, C/I 1 MHz. | | 1 | | dB | 2 |
| C/I_{2ND} | 2 nd ACS, C/I 2 MHz. | | -25 | | dB | 2 |
| C/I_{3+N} | ACS, C/I (3+n) MHz offset [$n = 0, 1, 2, \dots$]. | | -51 | | dB | 2 |
| C/I_{Image} | Image blocking level. | | -30 | | dB | 2 |
| $C/I_{Image\pm 1MHz}$ | Adjacent channel to image blocking level (± 1 MHz). | | -31 | | dB | 2 |
| RX intermodulation³ | | | | | | |
| P_IMD_{2Mbps} | IMD performance, 2 Mbps, 3rd, 4th, and 5th offset channel. | | -41 | | dBm | 2 |
| P_IMD_{1Mbps} | IMD performance, 1 Mbps, 3rd, 4th, and 5th offset channel. | | -40 | | dBm | 2 |
| $P_IMD_{250kbps}$ | IMD performance, 250 kbps, 3rd, 4th, and 5th offset channel. | | -36 | | dBm | 2 |
| P_IMD_{BLE} | IMD performance, 1 Mbps BLE, 3rd, 4th, and 5th offset channel. | | -39 | | dBm | 2 |

1. As defined in the *Bluetooth Core Specification v4.0 Volume 6: Core System Package (Low Energy Controller Volume)*.
2. Wanted signal level at $P_{IN} = -67$ dBm. One interferer is used, having equal modulation as the wanted signal. The input power of the interferer where the sensitivity equals BER = 0.1% is presented.
3. Wanted signal level at $P_{IN} = -64$ dBm. Two interferers with equal input power are used. The interferer closest in frequency is not modulated, the other interferer is modulated equal with the wanted signal. The input power of interferers where the sensitivity equals BER = 0.1% is presented.

Table 33 Receiver specifications

8.5.5 Radio timing parameters

| Symbol | Description | 250 k | 1 M | 2 M | BLE | Jitter | Units |
|-----------------|--|-------|-----|-----|-----|--------|---------------|
| t_{TXEN} | Time between TXEN task and READY event. | 132 | 132 | 132 | 140 | 0 | μs |
| $t_{TXDISABLE}$ | Time between DISABLE task and DISABLED event when the radio was in TX. | 10 | 4 | 3 | 4 | 1 | μs |
| t_{RXEN} | Time between the RXEN task and READY event. | 130 | 130 | 130 | 138 | 0 | μs |
| $t_{RXDISABLE}$ | Time between DISABLE task and DISABLED event when the radio was in RX. | 0 | 0 | 0 | 0 | 1 | μs |
| $t_{TXCHAIN}$ | TX chain delay. | 5 | 1 | 0.5 | 1 | 0 | μs |
| $t_{RXCHAIN}$ | RX chain delay. | 12 | 2 | 2.5 | 3 | 0 | μs |

Table 34 Radio timing

8.5.6 Antenna matching network requirements

| Symbol | Description | Min. | Typ. | Max. | Units | Test level |
|--------------|--|------|-----------|------|----------|------------|
| $Z_{ANT1,2}$ | Optimum differential impedance at 2.4 GHz seen into the matching network from pin ANT1 and ANT2. | | 15+j x 85 | | Ω | 1 |

Table 35 Optimum differential load impedance for QFN48 package

8.6 Received Signal Strength Indicator (RSSI) specifications

| Symbol | Description | Note | Min. | Typ. | Max. | Units | Test level |
|----------------------------|---|---------------------------------|------|------|---------|---------------|------------|
| RSSI _{ACC} | RSSI accuracy. | Valid range -50 dBm to -80 dBm. | | | ± 6 | dB | 2 |
| RSSI _{RESOLUTION} | RSSI resolution. | | | 1 | | dB | 1 |
| RSSI _{PERIOD} | Sample period. | | 8.8 | | | μs | 1 |
| RSSI _{CURRENT} | Current consumption in addition to I_{RX} . | | | 250 | | μA | 1 |

Table 36 RSSI specifications

8.7 Universal Asynchronous Receiver/Transmitter (UART) specifications

| Symbol | Description | Note | Min. | Typ. | Max. | Units | Test level |
|-----------------------|-------------------------------|------|------|------|------|---------------|------------|
| I_{UART1M} | Run current at max baud rate. | | | 230 | | μA | 1 |
| I_{UART115k} | Run current at 115200 bps. | | | 220 | | μA | 1 |
| I_{UART1k2} | Run current at 1200 bps. | | | 210 | | μA | 1 |
| f_{UART} | Baud rate for UART. | | 1.2 | | 1000 | kbps | N/A |

Table 37 UART specifications

8.8 Serial Peripheral Interface Slave (SPIS) specifications

| Symbol | Description | Min. | Typ. | Max. | Units | Test level |
|----------------|---|-------|------|------|---------------|------------|
| $I_{SPIS125K}$ | Run current for SPI slave at 125 kbps. ¹ | | 180 | | μA | 1 |
| I_{SPIS2M} | Run current for SPI slave at 2 Mbps. ¹ | | 183 | | μA | 1 |
| f_{SPIS} | Bit rates for SPIS. | 0.125 | | 2 | Mbps | N/A |

1. CSN asserted.

Table 38 SPIS specifications

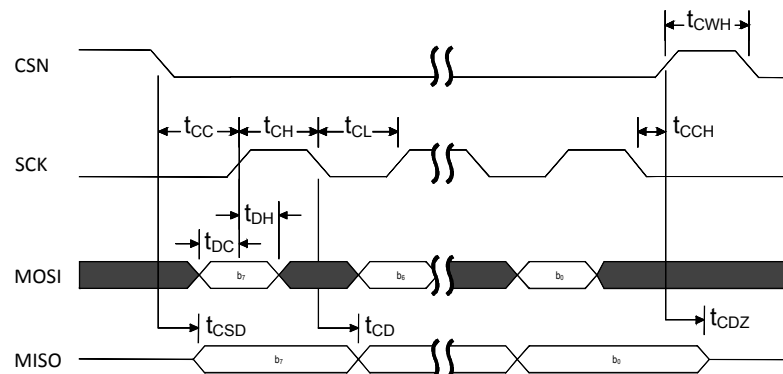

Figure 9 SPIS timing diagram, one byte transmission, SPI Mode 0

| Symbol | Description | Note | Min. | Typ. | Max. | Units | Test level |
|------------|----------------------------|---|--------------|------|--------------|-------|------------|
| t_{DC} | Data to SCK setup. | | 10 | | | ns | 1 |
| t_{DH} | SCK to Data hold. | | 10 | | | ns | 1 |
| t_{CSD} | CSN to Data valid. | Low power mode. ¹ Constant latency mode. ¹ | | | 7100 2100 | ns | 1 |
| t_{CD} | SCK to Data Valid. | | | | 60 | ns | 1 |
| t_{CL} | SCK Low time. | | 40 | | | ns | 1 |
| t_{CH} | SCK High time. | | 40 | | | ns | 1 |
| t_{CC} | CSN to SCK Setup. | Low power mode. ¹ Constant latency mode. ¹ | 7000 2000 | | | ns | 1 |
| t_{CCH} | Last SCK edge to CSN Hold. | | 2000 | | | ns | 1 |
| t_{CWH} | CSN Inactive time. | | 300 | | | ns | 1 |
| t_{CDZ} | CSN to Output High Z. | | | | 40 | ns | 1 |
| f_{SCK} | SCK frequency. | | 0.125 | | 2 | MHz | 1 |
| t_R, t_F | SCK Rise and Fall time. | | | | 100 | ns | 1 |

1. For more information on how to control the sub power modes, see the *nRF51 Series Reference Manual*.

Table 39 SPIS timing parameters

8.9 Serial Peripheral Interface (SPI) Master specifications

| Symbol | Description | Min. | Typ. | Max. | Units | Test level |
|---------------|---|-------|------|------|---------------|------------|
| $I_{SPI125K}$ | Run current for SPI master at 125 kbps. | | 180 | | μA | 1 |
| I_{SPI4M} | Run current for SPI master at 4 Mbps. | | 200 | | μA | 1 |
| f_{SPI} | Bit rates for SPI. | 0.125 | | 4 | Mbps | N/A |

Table 40 SPI specifications

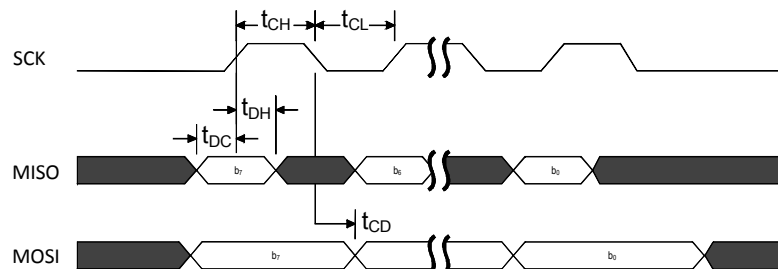

Figure 10 SPI timing diagram, one byte transmission, SPI mode 0

| Symbol | Description | Note | Min. | Typ. | Max. | Units | Test level |
|------------|-------------------------|----------------------------|-------|------|-----------------|-------|------------|
| t_{DC} | Data to SCK setup. | | 10 | | | ns | 1 |
| t_{DH} | SCK to Data hold. | | 10 | | | ns | 1 |
| t_{CD} | SCK to Data valid. | $C_{LOAD} = 10 \text{ pF}$ | | | 97 ¹ | ns | 1 |
| t_{CL} | SCK Low time. | | 40 | | | ns | 1 |
| t_{CH} | SCK High time. | | 40 | | | ns | 1 |
| f_{SCK} | SCK Frequency. | | 0.125 | | 4 | MHz | 1 |
| t_R, t_F | SCK Rise and Fall time. | | | | 100 | ns | 1 |

1. Increases/decreases with 1.2 ns/pF load.

Table 41 SPI timing parameters

8.10 I2C compatible Two Wire Interface (TWI) specifications

| Symbol | Description | Note | Min. | Typ. | Max. | Units | Test level |
|-----------------|--|---|------|--------|------|---------------|------------|
| I_{2W100K} | Run current for TWI at 100 kbps. | | | 380 | | μA | 1 |
| I_{2W400K} | Run current for TWI at 400 kbps. | | | 400 | | μA | 1 |
| f_{2W} | Bit rates for TWI. | | 100 | | 400 | kbps | N/A |
| $t_{TWI,START}$ | Time from STARTRX/STARTTX task is given until start condition. | Low power mode. ¹ Constant latency mode. ¹ | | 3 1 | 4.4 | μs | 1 |

1. For more information on how to control the sub power modes, see the *nRF51 Series Reference Manual*.

Table 42 TWI specifications

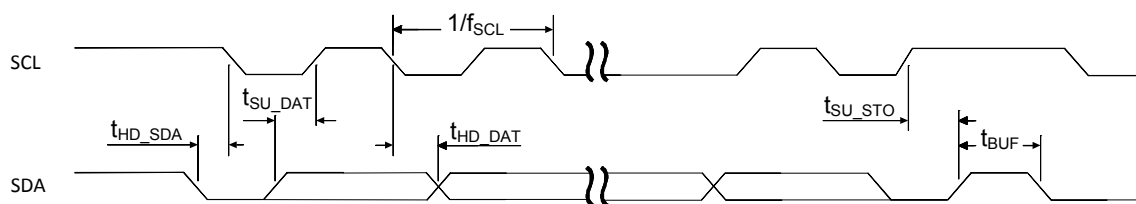

Figure 11 SCL/SDA timing

| Symbol | Description | Standard | | Fast | | Units | Test level |
|---------------|---|----------|------|------|------|-------|------------|
| | | Min. | Max. | Min. | Max. | | |
| f_{SCL} | SCL clock frequency. | | 100 | | 400 | kHz | 1 |
| t_{HD_STA} | Hold time for START and repeated START condition. | 5200 | | 1300 | | ns | 1 |
| t_{SU_DAT} | Data setup time before positive edge on SCL. | 300 | | 300 | | ns | 1 |
| t_{HD_DAT} | Data hold time after negative edge on SCL. | 300 | | 300 | | ns | 1 |
| t_{SU_STO} | Setup time from SCL goes high to STOP condition. | 5200 | | 1300 | | ns | 1 |
| t_{BUF} | Bus free time between STOP and START conditions. | 4700 | | 1300 | | ns | 1 |

Table 43 TWI timing parameters

8.11 GPIO Tasks and Events (GPIOTE) specifications

| Symbol | Description | Min. | Typ. | Max. | Units | Test level |
|--------------------------|---|------|------|------|---------------|------------|
| $I_{\text{GPIOTE,IN}}$ | Run current with 1 or more GPIOTE active channels in Input mode. | | 22 | | μA | 1 |
| $I_{\text{GPIOTE,OUT}}$ | Run current with 1 or more GPIOTE active channels in Output mode. | | 0.1 | | μA | 1 |
| $I_{\text{GPIOTE,IDLE}}$ | Run current when all channels in Idle mode. PORT event can be generated with a delay of up to t_{1V2} . | | 0.1 | | μA | 1 |

Table 44 GPIOTE specifications

Note: Setting up one or more GPIO DETECT signals to generate PORT EVENT, which can be used either as a wakeup source or to give an interrupt, will not lead to an increase of the current consumption.

8.12 Analog to Digital Converter (ADC) specifications

| Symbol | Description | Note | Min. | Typ. | Max. | Units | Test level |
|-------------------------------|--|--|------|--------|------|---------------|------------|
| $\text{DNL}_{10\text{b}}$ | Differential non-linearity (10 bit mode). | | | < 1 | | LSB | 2 |
| $\text{INL}_{10\text{b}}$ | Integral non-linearity (10 bit mode). | | | 2 | | LSB | 2 |
| V_{OS} | Offset error. | | -2 | | +2 | % | 2 |
| e_{G} | Gain error. | | -2 | | +2 | % | 2 |
| $V_{\text{REF_INT}}$ | Internal reference voltage. | | -1.5 | 1.20 V | +1.5 | % | 2 |
| $\text{TC}_{\text{REF_INT}}$ | Internal reference voltage drift. | | -200 | | +200 | ppm/°C | 2 |
| $V_{\text{REF_EXT}}$ | External reference voltage. | | 0.83 | 1.2 | 1.3 | V | 1 |
| $t_{\text{ADC}10\text{b}}$ | Time required to convert a single sample in 10 bit mode. | | | 68 | | μs | 1 |
| $t_{\text{ADC}9\text{b}}$ | Time required to convert a single sample in 9 bit mode. | | | 36 | | μs | 1 |
| $t_{\text{ADC}8\text{b}}$ | Time required to convert a single sample in 8 bit mode. | | | 20 | | μs | 1 |
| I_{ADC} | Current drawn by ADC during conversion. | | | 260 | | μA | 1 |
| $\text{ADC_ERR_}1\text{V}8$ | | | | 3 | | LSB | 2 |
| $\text{ADC_ERR_}2\text{V}2$ | Absolute error when used for battery measurement at 1.8 V, 2.2 V, 2.6 V, 3.0 V, and 3.4 V. | Internal reference, input from VDD/3, 10 bit mode. | | 2 | | LSB | 2 |
| $\text{ADC_ERR_}2\text{V}6$ | | | | 1 | | LSB | 2 |
| $\text{ADC_ERR_}3\text{V}0$ | | | | 1 | | LSB | 2 |
| $\text{ADC_ERR_}3\text{V}4$ | | | | 1 | | LSB | 2 |

Table 45 Analog to Digital Converter (ADC) specifications

8.13 Timer (TIMER) specifications

| Symbol | Description | Note | Min. | Typ. | Max. | Units | Test level |
|--------------------------|--|------|------|------|------|---------------|------------|
| $I_{\text{TIMER0/1/2}}$ | Timer at 16 MHz run current. | | | 30 | | μA | 1 |
| $t_{\text{TIMER,START}}$ | Time from START task is given until timer starts counting. | | | 0.25 | | μs | 1 |

Table 46 Timer specifications

8.14 Real Time Counter (RTC)

| Symbol | Description | Min. | Typ. | Max. | Units | Test level |
|------------------|-----------------------|------|------|------|---------------|------------|
| I_{RTC} | Timer (LFCLK source). | | 0.1 | | μA | 1 |

Table 47 RTC

8.15 Temperature sensor (TEMP)

| Symbol | Description | Min. | Typ. | Max. | Units | Test level |
|--------------------|--|------|------|------|--------------------|------------|
| I_{TEMP} | Run current for Temperature sensor. | | 185 | | μA | 1 |
| t_{TEMP} | Time required for temperature measurement. | | 35 | | μs | 1 |
| T_{RANGE} | Temperature sensor range. | -25 | | 75 | $^{\circ}\text{C}$ | N/A |
| T_{ACC} | Temperature sensor accuracy. | -4 | | +4 | $^{\circ}\text{C}$ | N/A |
| T_{RES} | Temperature sensor resolution. | | 0.25 | | $^{\circ}\text{C}$ | 1 |

Table 48 Temperature sensor

8.16 Random Number Generator (RNG) specifications

| Symbol | Description | Note | Min. | Typ. | Max. | Units | Test level |
|----------------------|------------------------------------|--|------|------|------|---------------|------------|
| I_{RNG} | Run current at 16 MHz. | | | 60 | | μA | 1 |
| $t_{\text{RNG,RAW}}$ | Run time per byte in RAW mode. | Uniform distribution of 0 and 1 is not guaranteed. | | 167 | | μs | 1 |
| $t_{\text{RNG,UNI}}$ | Run time per byte in Uniform mode. | Uniform distribution of 0 and 1 is guaranteed. Time to generate a byte cannot be guaranteed. | | 677 | | μs | 1 |

Table 49 Random Number Generator (RNG) specifications

8.17 AES Electronic Codebook Mode Encryption (ECB) specifications

| Symbol | Description | Min. | Typ. | Max. | Units | Test level |
|--------------------------|---------------------------------------|------|------|------|---------------|------------|
| I_{ECB} | Run current for ECB. | | 550 | | μA | 1 |
| $t_{START, ECB, ENDECB}$ | Time for a 16 byte AES block encrypt. | | 8.5 | 17 | μs | 1 |

Table 50 ECB specifications

8.18 AES CCM Mode Encryption (CCM) specifications

| Symbol | Description | Min. | Typ. | Max. | Units | Test level |
|-----------|----------------------|------|------|------|---------------|------------|
| I_{CCM} | Run current for CCM. | | 550 | | μA | 1 |

Table 51 CCM specifications

8.19 Accelerated Address Resolver (AAR) specifications

| Symbol | Description | Min. | Typ. | Max. | Units | Test level |
|-----------------------|--|------|------|------|---------------|------------|
| I_{AAR} | Run current for AAR. | | 550 | | μA | 1 |
| $t_{START, RESOLVED}$ | Time for address resolution of 8 IRKs. | | 68 | | μs | 1 |

Table 52 AAR specifications

8.20 Watchdog Timer (WDT) specifications

| Symbol | Description | Min. | Typ. | Max. | Units | Test level |
|-----------|------------------------------------|------------------|------|--------|---------------|------------|
| I_{WDT} | Run current for watchdog timer. | | 0.1 | | μA | 1 |
| t_{WDT} | Time out interval, watchdog timer. | 30 μs | | 36 hrs | | 1 |

Table 53 Watchdog Timer specifications

8.21 Quadrature Decoder (QDEC) specifications

| Symbol | Description | Note | Min. | Typ. | Max. | Units | Test level |
|--------------|--|---------------------------------|------|------|-------|---------------|------------|
| I_{QDEC} | | | | 12 | | μA | 1 |
| t_{SAMPLE} | Time between sampling signals from quadrature decoder. | | 128 | | 16384 | μs | N/A |
| t_{LED} | Time from LED is turned on to signals are sampled. | Only valid for optical sensors. | 0 | | 511 | μs | N/A |

Table 54 Quadrature Decoder specifications

8.22 Non-Volatile Memory Controller (NVMC) specifications

| Symbol | Description | Note | Min. | Typ. | Max. | Units | Test level |
|-----------------|---------------------------------|------|------|------|------|---------------|------------|
| $t_{ERASEALL}$ | Erase flash memory. | | | 21 | | ms | 1 |
| $t_{PAGEERASE}$ | Erase page in flash memory. | | | 21 | | ms | 1 |
| t_{WRITE}^1 | Write one word to flash memory. | | | 22 | 43 | μs | 1 |

1. Typical value applies when writing 32 words or more. Maximum value applies when writing a single word.

Table 55 NVMC specifications

Note: The CPU will be halted for the duration of NVMC operations.

8.23 General Purpose I/O (GPIO) specifications

| Symbol | Parameter (condition) | Note | Min. | Typ. | Max. | Units |
|----------|---|------|---------|------|---------|------------|
| V_{IH} | Input high voltage. | | 0.7 VDD | | VDD | V |
| V_{IL} | Input low voltage. | | VSS | | 0.3 VDD | V |
| V_{OH} | Output high voltage (std. drive, 0.5 mA). | | VDD-0.3 | | VDD | V |
| V_{OH} | Output high voltage (high-drive, 5 mA). | 1 | VDD-0.3 | | VDD | V |
| V_{OL} | Output low voltage (std. drive, 0.5 mA). | | VSS | | 0.3 | V |
| V_{OL} | Output low voltage (high-drive, 5 mA). | | VSS | | 0.3 | V |
| R_{PU} | Pull-up resistance. | | 11 | 13 | 16 | k Ω |
| R_{PD} | Pull-down resistance. | | 11 | 13 | 16 | k Ω |

1. Maximum number of pins with 5 mA high drive is 3.

Table 56 General Purpose I/O (GPIO) specifications

8.24 Low Power Comparator (LPCOMP) specifications

| Symbol | Description | Min. | Typ. | Max. | Units | Test level |
|--------------------|--|------|------|--------|---------------|------------|
| I_{LPC} | Run current for LPCOMP. | | 0.5 | | μA | 1 |
| $t_{LPCANADETOFF}$ | Time from VIN crossing to ANADETECT signal generated when in System OFF. | | | 15^1 | μs | 1 |
| $t_{LPCANADETON}$ | Time from VIN crossing to ANADETECT signal generated when in System ON. | | | 15^1 | μs | 1 |

1. For 50 mV overdrive

Table 57 Low power comparator specifications

9 Mechanical specifications

9.1 QFN48 package

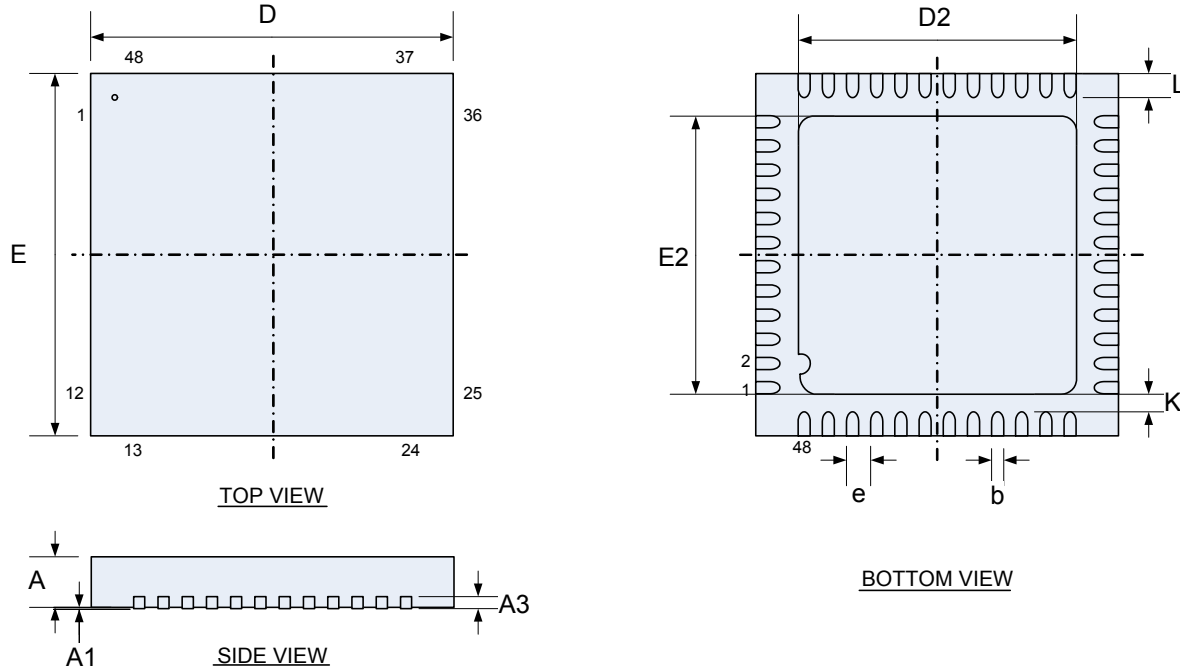

Figure 12 QFN48 6 x 6 mm package

| Package | A | A1 | A3 | b | D, E | D2, E2 | e | K | L | |
|---------------|------|------|-----|------|------|--------|-----|------|------|-------------|
| QFN48 (6 x 6) | 0.80 | 0.00 | | 0.15 | | 4.50 | | 0.20 | 0.35 | Min. |
| | 0.85 | 0.02 | 0.2 | 0.20 | 6.0 | 4.60 | 0.4 | | 0.40 | Nom. |
| | 0.90 | 0.05 | | 0.25 | | 4.70 | | | 0.45 | Max. |

Table 58 QFN48 dimensions in millimeters

9.2 WLCSP package

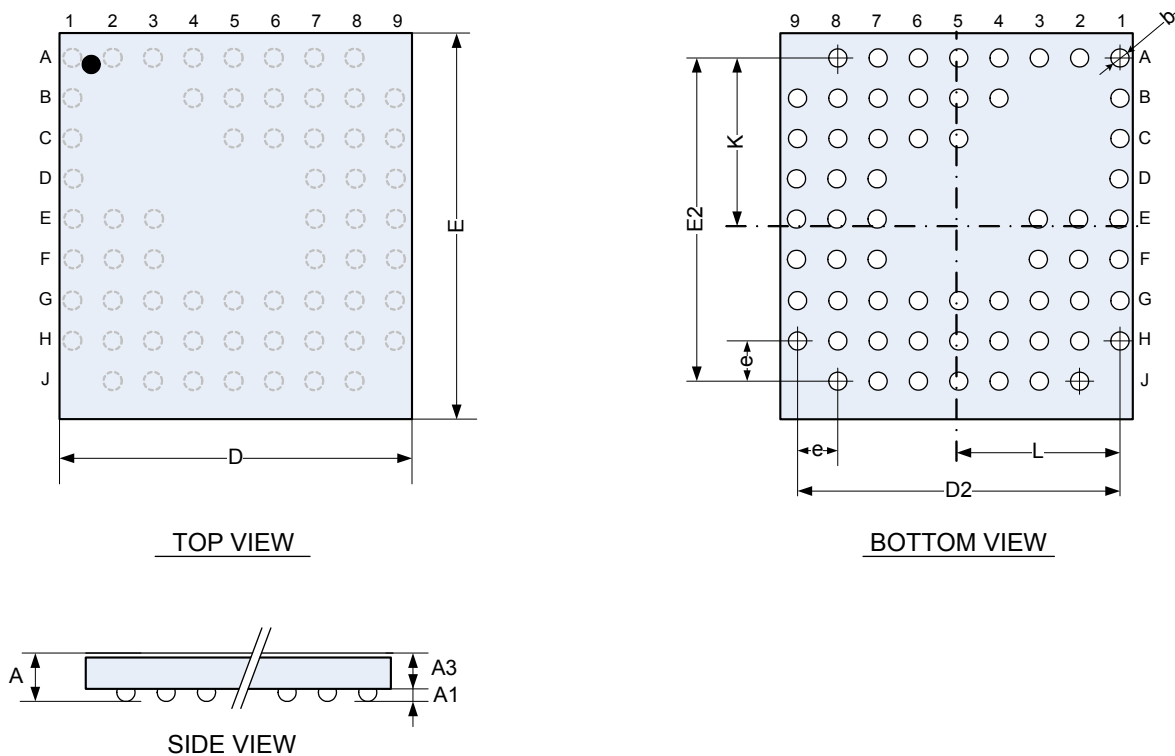

Figure 13 WLCSP package

| Package | A | A1 | A3 | b | D | E | D2 | E2 | e | K | L | |
|---------|------|------|------|------|------|------|------|------|-----|------|------|-------------|
| WLCSP | | 0.12 | 0.31 | 0.16 | 3.45 | 3.78 | | | | | | Min. |
| | 0.50 | 0.15 | 0.33 | 0.20 | 3.50 | 3.83 | 3.20 | 3.20 | 0.4 | 1.66 | 1.61 | Nom. |
| | 0.55 | 0.18 | 0.35 | 0.24 | 3.55 | 3.88 | | | | | | Max. |

Table 59 WLCSP package dimensions in millimeters

10 Ordering information

10.1 Chip marking

| | | | | | |
|-----|----|-----|----|-----|-----|
| N | 5 | 1 | 4 | 2 | 2 |
| <P> | P> | <V> | V> | <H> | <P> |
| <Y> | Y> | <W> | W> | <L> | L> |

Table 60 Package marking

10.2 Inner box label

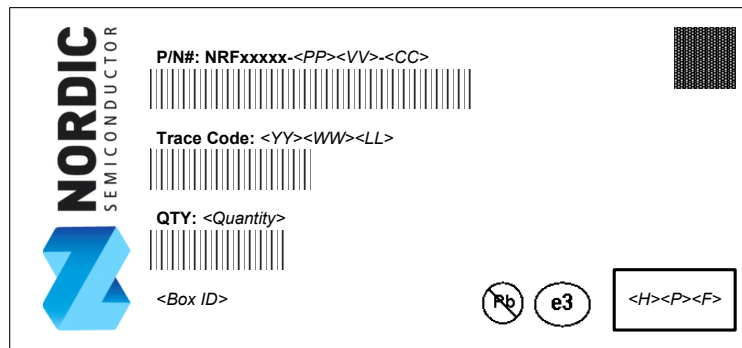

Figure 14 Inner box label

10.3 Outer box label















| | |
|--|---|
|  | |
| FROM:  | TO:  |
| DEVICE: NRFxxxx-<PP><VV>-<CC>    | |
| S/O No.: <Nordic Sales Order>  | |
| CUSTOMER PO No.: <Customer Purchase Order>  | |
| WF LOT No.: <Wafer Lot Number>  | |
| Trace Code: <YY><WW><LL>  | |
| QTY: <Quantity>  | |
| PACKAGE COUNT:  of  | PACKAGE WEIGHT:  KGS  |
| COUNTRY OF ORIGIN: <Country> | |

Figure 15 Outer box label

10.4 Order code

| | | | | | | | | | | | | | | | |
|---|---|---|---|---|---|---|---|---|----|----|----|----|---|----|----|
| n | R | F | 5 | 1 | 4 | 2 | 2 | - | <P | P> | <V | V> | - | <C | C> |
|---|---|---|---|---|---|---|---|---|----|----|----|----|---|----|----|

Table 61 Order code

10.5 Abbreviations

| Abbreviation | Definition and Implemented Codes |
|--------------|---|
| N51/nRF51 | nRF51 series product |
| 422 | Part code |
| <PP> | Package code |
| <VV> | Variant code |
| <H><P><F> | Build code H - Hardware version code P - Production configuration code (production site, etc.) F - Firmware version (Only visible on shipping container label) |
| <YY><WW><LL> | Tracking code YY - Year code WW - Assembly week number LL - Wafer lot code |
| <CC> | Container code |

Table 62 Abbreviations

10.6 Code ranges and values

| <PP> | Packet | Size (mm) | Pin/Ball Count | Pitch (mm) |
|------|--------|-------------|----------------|------------|
| QF | QFN | 6 x 6 | 48 | 0.4 |
| CE | WLCSP | 3.50 x 3.83 | 62 | 0.4 |

Table 63 Package codes

| <VV> | Flash (kB) | RAM (kB) | DC/DC Bond-out |
|------|------------|----------|----------------|
| AA | 256 | 16 | YES |
| AB | 128 | 16 | YES |

Table 64 Variant codes

| <H> | Description |
|--------|--|
| [A..Z] | Hardware version/revision identifier (incremental) |

Table 65 Hardware version codes

| <P> | Description |
|--------|---|
| [0..9] | Production device identifier (incremental) |
| [A..Z] | Engineering device identifier (incremental) |

Table 66 Production version codes

| <F> | Description |
|--------------|--|
| [A..N, P..Z] | Version of programmed firmware |
| [0] | Delivered without preprogrammed firmware |

Table 67 Firmware version codes

| <YY> | Description |
|----------|-------------------------------|
| [12..99] | Production year: 2012 to 2099 |

Table 68 Year codes

| <WW> | Description |
|---------|--------------------|
| [1..52] | Week of production |

Table 69 Week codes

| <LL> | Description |
|----------|---------------------------------|
| [AA..ZZ] | Wafer production lot identifier |

Table 70 Lot codes

| <CC> | Description |
|------|-------------|
| R7 | 7" Reel |
| R | 13" Reel |
| T | Tray |

Table 71 Container codes

10.7 Product options

10.7.1 nRF ICs

| Order code | MOQ ¹ |
|---|------------------|
| nRF51422-QFAA-R7 nRF51422-QFAB-R7 | 1000 |
| nRF51422-QFAA-R nRF51422-QFAB-R nRF51422-CEAA-R | 3000 |
| nRF51422-QFAA-T nRF51422-QFAB-T | 490 |

1. Minimum Order Quantity.

Table 72 Order code

10.7.2 Development tools

| Order code | Description |
|--------------------------|--|
| nRF51422-DK ¹ | nRF51422 Development Kit. ² |
| nRF51422-EK ¹ | nRF51422 Evaluation Kit. |
| nRF6700 | nRFgo Starter Kit. |

1. Uses the nRF51422-QFAA version of the chip.
2. Requires nRF6700 nRFgo Starter Kit.

Table 73 Development tools

11 Reference circuitry

For the following reference layouts, C_{pcb} , between X1 and XC1/XC2, is estimated to 0.5 pF each.

The exposed center pad of the QFN48 package must be connected to supply ground for proper device operation.

11.1 PCB guidelines

A well designed PCB is necessary to achieve good RF performance. A poor layout can lead to loss in performance or functionality. A qualified RF layout for the IC and its surrounding components, including matching networks, can be downloaded from www.nordicsemi.com.

To ensure optimal performance it is essential that you follow the schematics- and layout references closely. Especially in the case of the antenna matching circuitry (components between device pins ANT1, ANT2, VDD_PA and the antenna), any changes to the layout can change the behavior, resulting in degradation of RF performance or a need to change component values. All the reference circuits are designed for use with a 50 ohm single end antenna.

A PCB with a minimum of two layers, including a ground plane, is recommended for optimal performance. On PCBs with more than two layers, put a keep-out area on the inner layers directly below the antenna matching circuitry (components between device pins **ANT1**, **ANT2**, **VDD_PA**, and the antenna) to reduce the stray capacitances that influence RF performance.

A matching network is needed between the differential RF pins **ANT1** and **ANT2** and the antenna, to match the antenna impedance (normally 50 ohm) to the optimum RF load impedance for the chip. For optimum performance, the impedance for the matching network should be set as described in **Section 8.5.6 "Antenna matching network requirements"** on page 44 along with the recommended QFN48 package reference circuitry from **Section 11.2 "QFN48 package"** on page 62.

The DC supply voltage should be decoupled as close as possible to the VDD pins with high performance RF capacitors. See the schematics for recommended decoupling capacitor values. The supply voltage for the chip should be filtered and routed separately from the supply voltages of any digital circuitry.

Long power supply lines on the PCB should be avoided. All device grounds, VDD connections, and VDD bypass capacitors must be connected as close as possible to the IC. For a PCB with a top-side RF ground plane, the VSS pins should be connected directly to the ground plane. For a PCB with a bottom ground plane, the best technique is to have via holes as close as possible to the VSS pads. A minimum of one via hole should be used for each VSS pin.

Full-swing digital data or control signals should not be routed close to the crystal or the power supply lines. Capacitive loading of full-swing digital output lines should be minimized in order to avoid radio interference.

11.2 QFN48 package

Documentation for the QFN48 package reference circuit, including Altium Designer files, PCB layout files, and PCB production files can be downloaded from www.nordicsemi.com.

11.2.1 QFN48 schematic with internal LDO regulator

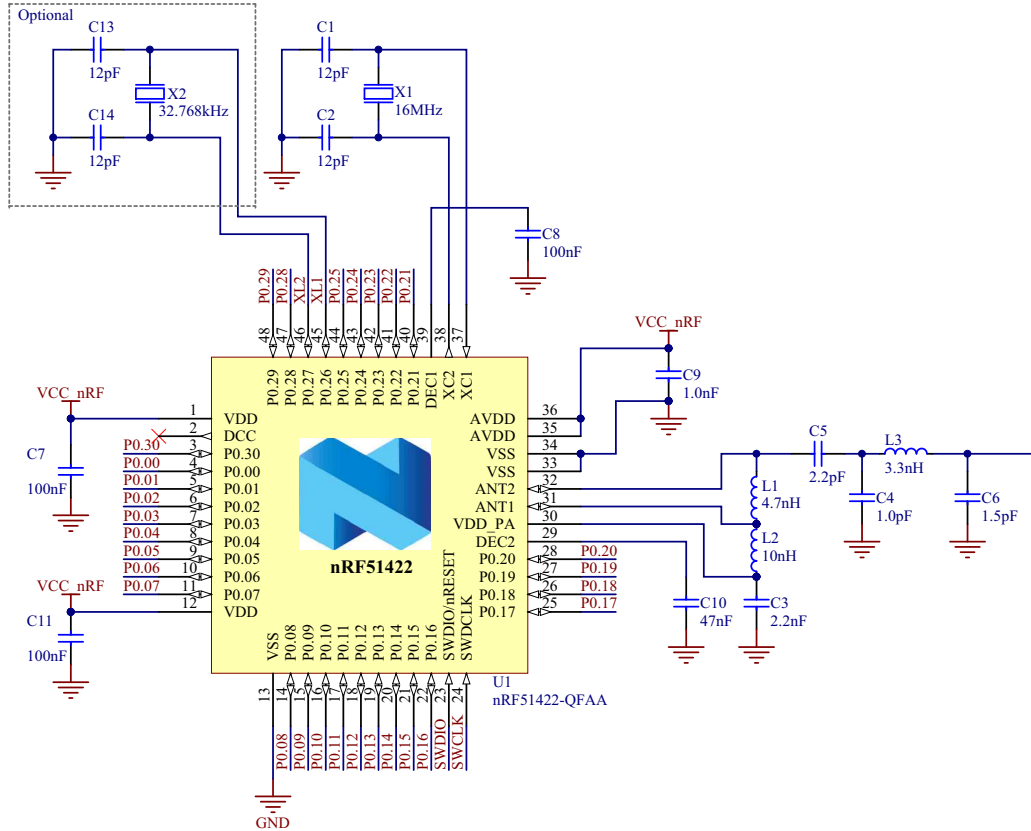

Figure 16 QFN48 with internal LDO regulator

11.2.1.1 Bill of Materials

| Designator | Value | Description | Footprint |
|------------------|--------------------------------|--|----------------------|
| C1, C2, C13, C14 | 12 pF | Capacitor, NP0, $\pm 2\%$ | 0402 |
| C3 | 2.2 nF | Capacitor, X7R, $\pm 10\%$ | 0402 |
| C4 | 1.0 pF | Capacitor, NP0, ± 0.1 pF | 0402 |
| C5 | 2.2 pF | Capacitor, NP0, ± 0.1 pF | 0402 |
| C6 | 1.5 pF | Capacitor, NP0, ± 0.1 pF | 0402 |
| C7, C8, C11 | 100 nF | Capacitor, X7R, $\pm 10\%$ | 0402 |
| C9 | 1.0 nF | Capacitor, X7R, $\pm 10\%$ | 0402 |
| C10 | 47 nF | Capacitor, X7R, $\pm 10\%$ | 0402 |
| L1 | 4.7 nH | High frequency chip inductor $\pm 5\%$ | 0402 |
| L2 | 10 nH | High frequency chip inductor $\pm 5\%$ | 0402 |
| L3 | 3.3 nH | High frequency chip inductor $\pm 5\%$ | 0402 |
| U1 | nRF51422-QFAA nRF51422-QFAB | RF SoC | QFN40P600X600X90-48N |
| X1 | 16 MHz | Crystal SMD 2520, 16 MHz, 8 pF, ± 40 ppm | 2.5 x 2.0 mm |
| X2 | 32.768 kHz | Crystal SMD FC-135, 32.768 kHz, 9 pF, ± 20 ppm | FC-135 |

Table 74 QFN48 with internal LDO regulator

11.2.2 QFN48 schematic with 1.8 V low voltage mode

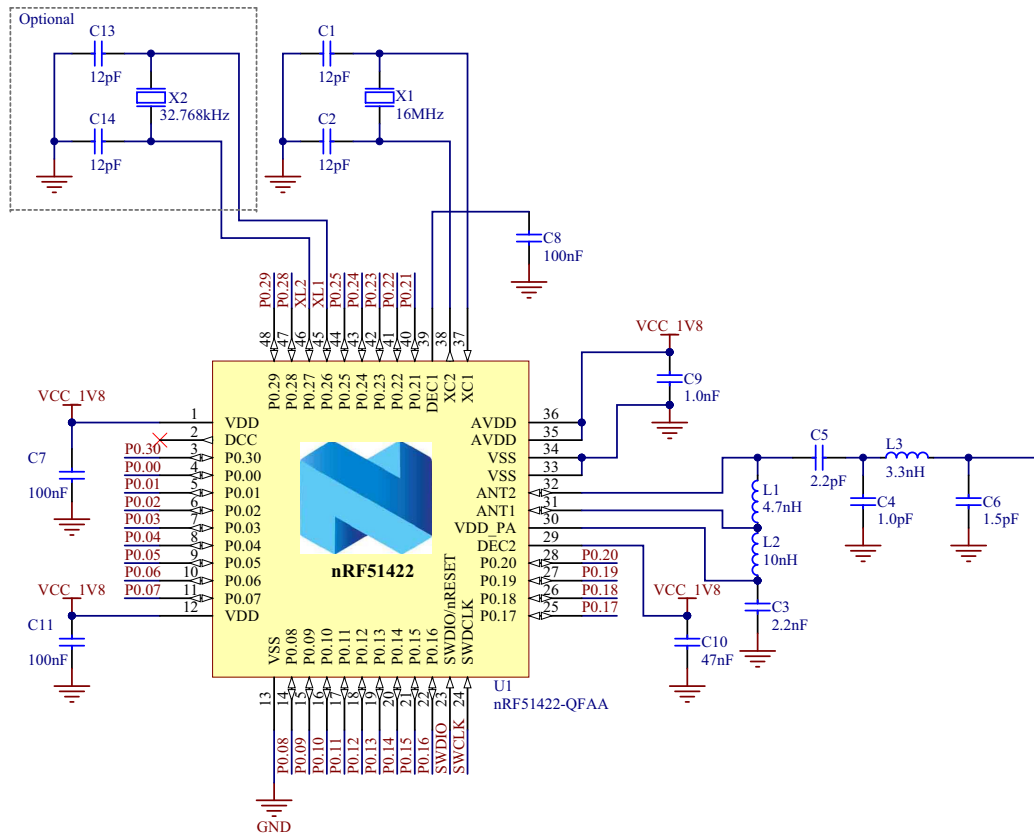

Figure 17 QFN48 with 1.8 V low voltage mode

11.2.2.1 Bill of Materials

| Designator | Value | Description | Footprint |
|------------------|--------------------------------|--|----------------------|
| C1, C2, C13, C14 | 12 pF | Capacitor, NP0, $\pm 2\%$ | 0402 |
| C3 | 2.2 nF | Capacitor, X7R, $\pm 10\%$ | 0402 |
| C4 | 1.0 pF | Capacitor, NP0, ± 0.1 pF | 0402 |
| C5 | 2.2 pF | Capacitor, NP0, ± 0.1 pF | 0402 |
| C6 | 1.5 pF | Capacitor, NP0, ± 0.1 pF | 0402 |
| C7, C8, C11 | 100 nF | Capacitor, X7R, $\pm 10\%$ | 0402 |
| C9 | 1.0 nF | Capacitor, X7R, $\pm 10\%$ | 0402 |
| C10 | 47 nF | Capacitor, X7R, $\pm 10\%$ | 0402 |
| L1 | 4.7 nH | High frequency chip inductor $\pm 5\%$ | 0402 |
| L2 | 10 nH | High frequency chip inductor $\pm 5\%$ | 0402 |
| L3 | 3.3 nH | High frequency chip inductor $\pm 5\%$ | 0402 |
| U1 | nRF51422-QFAA nRF51422-QFAB | RF SoC | QFN40P600X600X90-48N |
| X1 | 16 MHz | Crystal SMD 2520, 16 MHz, 8 pF, ± 40 ppm | 2.5 x 2.0 mm |
| X2 | 32.768 kHz | Crystal SMD FC-135, 32.768 kHz, 9 pF, ± 20 ppm | FC-135 |

Table 75 QFN48 with 1.8 V low voltage mode

11.2.3 QFN48 schematic with internal DC/DC converter

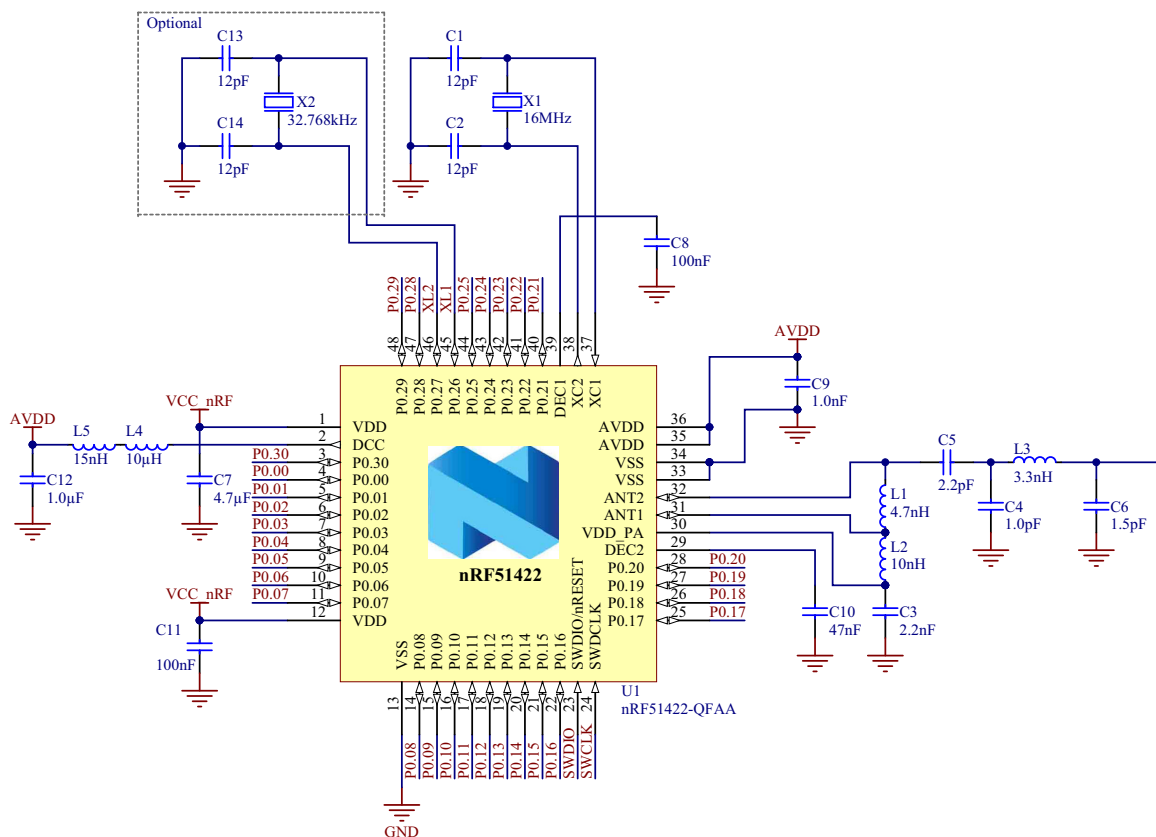

Figure 18 QFN48 with DC/DC converter

11.2.3.1 Bill of Materials

| Designator | Value | Description | Footprint |
|------------------|--------------------------------|--|----------------------|
| C1, C2, C13, C14 | 12 pF | Capacitor, NP0, $\pm 2\%$ | 0402 |
| C3 | 2.2 nF | Capacitor, X7R, $\pm 10\%$ | 0402 |
| C4 | 1.0 pF | Capacitor, NP0, ± 0.1 pF | 0402 |
| C5 | 2.2 pF | Capacitor, NP0, ± 0.1 pF | 0402 |
| C6 | 1.5 pF | Capacitor, NP0, ± 0.1 pF | 0402 |
| C7 | 4.7 μ F | Capacitor, X5R, $\pm 10\%$ | 0603 |
| C8, C11 | 100 nF | Capacitor, X7R, $\pm 10\%$ | 0402 |
| C9 | 1.0 nF | Capacitor, X7R, $\pm 10\%$ | 0402 |
| C10 | 47 nF | Capacitor, X7R, $\pm 10\%$ | 0402 |
| C12 | 1.0 μ F | Capacitor, X7R, $\pm 10\%$ | 0603 |
| L1 | 4.7 nH | High frequency chip inductor $\pm 5\%$ | 0402 |
| L2 | 10 nH | High frequency chip inductor $\pm 5\%$ | 0402 |
| L3 | 3.3 nH | High frequency chip inductor $\pm 5\%$ | 0402 |
| L4 | 10 μ H | Chip inductor, $I_{DC, min} = 50$ mA, $\pm 20\%$ | 0603 |
| L5 | 15 nH | High frequency chip inductor $\pm 10\%$ | 0402 |
| U1 | nRF51422-QFAA nRF51422-QFAB | RF SoC | QFN40P600X600X90-48N |
| X1 | 16 MHz | Crystal SMD 2520, 16 MHz, 8 pF, ± 40 ppm | 2.5 x 2.0 mm |
| X2 | 32.768 kHz | Crystal SMD FC-135, 32.768 kHz, 9 pF, ± 20 ppm | FC-135 |

Table 76 QFN48 with DC/DC converter

11.3 WLCSP package

Documentation for the WLCSP package reference circuit, including Altium Designer files, PCB layout files, and PCB production files, can be downloaded from www.nordicsemi.com.

11.3.1 WLCSP schematic with internal LDO regulator

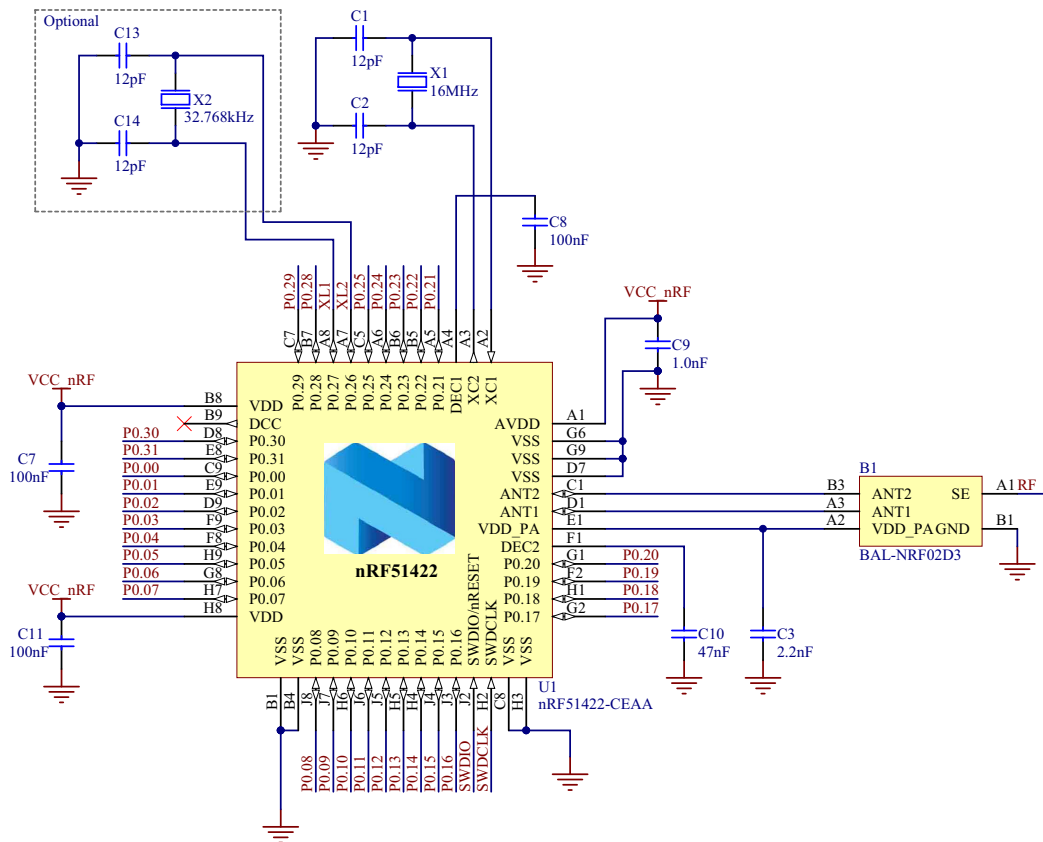

Figure 19 WLCSP with internal LDO regulator

11.3.1.1 Bill of Materials

| Designator | Value | Description | Footprint |
|------------------|---------------|---|-------------------------|
| B1 | BAL-NRF02D3 | ST Microelectronics, 50 Ω balun transformer for 2.45 GHz ISM | BAL-ST-WLCSP |
| C1, C2, C13, C14 | 12 pF | Capacitor, NP0, $\pm 2\%$ | 0402 |
| C3 | 2.2 nF | Capacitor, X7R, $\pm 10\%$ | 0402 |
| C7, C8, C11 | 100 nF | Capacitor, X7R, $\pm 10\%$ | 0402 |
| C9 | 1.0 nF | Capacitor, X7R, $\pm 10\%$ | 0402 |
| C10 | 47 nF | Capacitor, X7R, $\pm 10\%$ | 0402 |
| U1 | nRF51422-CEAA | RF SoC | BGA62C40P9X9_383X350X55 |
| X1 | 16 MHz | Crystal SMD 2520, 16 MHz, 8 pF, ± 40 ppm | 2.5 x 2.0 mm |
| X2 | 32.768 kHz | Crystal SMD FC-135, 32.768 kHz, 9 pF, ± 20 ppm | FC-135 |

Table 77 WLCSP with internal LDO regulator

11.3.2 WLCSP schematic with 1.8 V low voltage mode

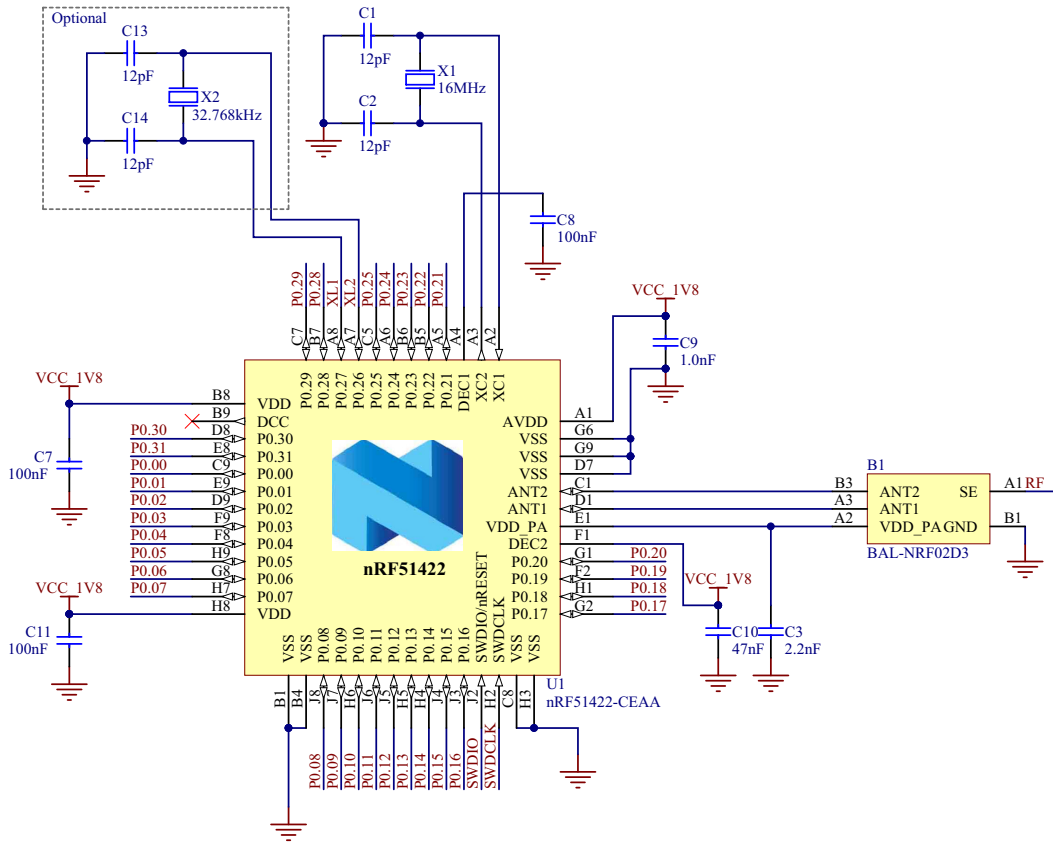

Figure 20 WLCSP with 1.8 V low voltage mode

11.3.2.1 Bill of Materials

| Designator | Value | Description | Footprint |
|------------------|---------------|---|-------------------------|
| B1 | BAL-NRF02D3 | ST Microelectronics, 50 Ω balun transformer for 2.45 GHz ISM | BAL-ST-WLCSP |
| C1, C2, C13, C14 | 12 pF | Capacitor, NP0, $\pm 2\%$ | 0402 |
| C3 | 2.2 nF | Capacitor, X7R, $\pm 10\%$ | 0402 |
| C7, C8, C11 | 100 nF | Capacitor, X7R, $\pm 10\%$ | 0402 |
| C9 | 1.0 nF | Capacitor, X7R, $\pm 10\%$ | 0402 |
| C10 | 47 nF | Capacitor, X7R, $\pm 10\%$ | 0402 |
| U1 | nRF51422-CEAA | RF SoC | BGA62C40P9X9_383X350X55 |
| X1 | 16 MHz | Crystal SMD 2520, 16 MHz, 8 pF, ± 40 ppm | 2.5 x 2.0 mm |
| X2 | 32.768 kHz | Crystal SMD FC-135, 32.768 kHz, 9 pF, ± 20 ppm | FC-135 |

Table 78 WLCSP with 1.8 V low voltage mode

11.3.3 WLCSP schematic with internal DC/DC converter

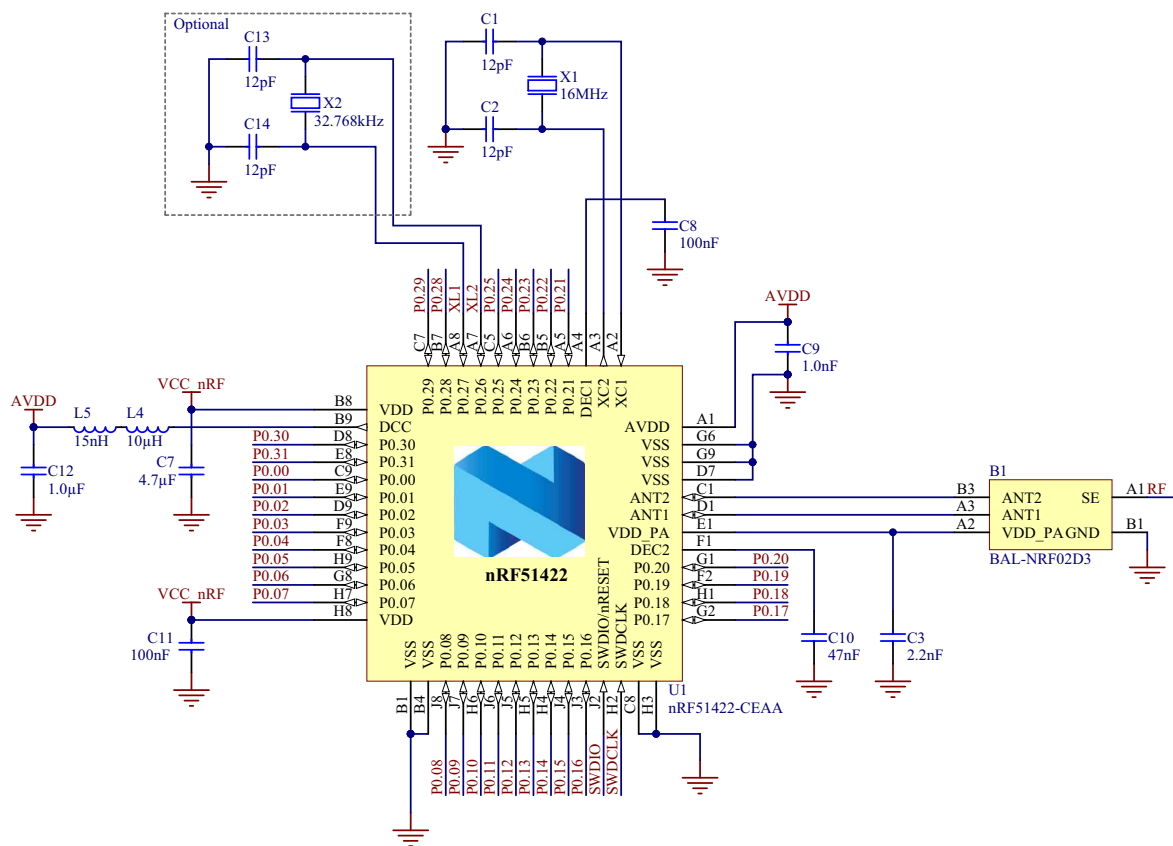

Figure 21 WLCSP with DC/DC converter

11.3.3.1 Bill of Materials

| Designator | Value | Description | Footprint |
|------------------|---------------|---|-------------------------|
| B1 | BAL-NRF02D3 | ST Microelectronics, 50 Ω balun transformer for 2.45 GHz ISM | BAL-ST-WLCSP |
| C1, C2, C13, C14 | 12 pF | Capacitor, NP0, $\pm 2\%$ | 0402 |
| C3 | 2.2 nF | Capacitor, X7R, $\pm 10\%$ | 0402 |
| C7 | 4.7 μ F | Capacitor, X5R, $\pm 10\%$ | 0603 |
| C8, C11 | 100 nF | Capacitor, X7R, $\pm 10\%$ | 0402 |
| C9 | 1.0 nF | Capacitor, X7R, $\pm 10\%$ | 0402 |
| C10 | 47 nF | Capacitor, X7R, $\pm 10\%$ | 0402 |
| C12 | 1.0 μ F | Capacitor, X7R, $\pm 10\%$ | 0603 |
| L4 | 10 μ H | Chip inductor, $I_{DC,min} = 50$ mA, $\pm 20\%$ | 0603 |
| L5 | 15 nH | High frequency chip inductor $\pm 10\%$ | 0402 |
| U1 | nRF51422-CEAA | RF SoC | BGA62C40P9X9_383X350X55 |
| X1 | 16 MHz | Crystal SMD 2520, 16 MHz, 8 pF, ± 40 ppm | 2.5 x 2.0 mm |
| X2 | 32.768 kHz | Crystal SMD FC-135, 32.768 kHz, 9 pF, ± 20 ppm | FC-135 |

Table 79 WLCSP with DC/DC converter

12 Glossary

| Term | Description |
|-------|---|
| EOC | Extreme Operating Conditions |
| GFSK | Gaussian Frequency-Shift Keying |
| GPIO | General Purpose Input Output |
| ISM | Industrial Scientific Medical |
| MOQ | Minimum Order Quantity |
| NOC | Nominal Operating Conditions |
| NVMC | Non-Volatile Memory Controller |
| QDEC | Quadrature Decoder |
| RF | Radio Frequency |
| RoHS | Restriction of Hazardous Substances |
| RSSI | Radio Signal Strength Indicator |
| SPI | Serial Peripheral Interface |
| TWI | Two-Wire Interface |
| UART | Universal Asynchronous Receiver Transmitter |
| WLCSP | Wafer Level Chip Scale Packet |

Table 80 Glossary