

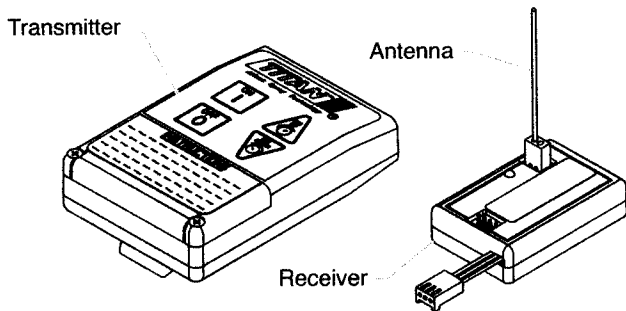

i-Remote

General Description

The i-Remote is a device that allows the user to control the spraying pressure of an electronically-controlled paint sprayer from a distance. Components of the i-Remote include a receiver, an antenna, and a transmitter.



WARNING

- Read all instructions and safety precautions for sprayer and spray gun before operating equipment.
- Do not allow transmitter or receiver to get wet.

Installation

Use the following procedures to install the receiver on the sprayer as well as install the battery in the transmitter.

NOTE: Installation of the receiver and antenna should be performed by a Titan authorized service center.

Installing the Receiver

The following procedures describe the installation of the receiver and antenna on two different types of sprayers.

Titan 440i, 640i, and XC Series Sprayers

The receiver is installed inside the electrical box of the pump housing on small Titan sprayers.

WARNING

Before proceeding, follow the Pressure Relief Procedure outlined in the sprayer manual. Additionally, follow all other warnings to reduce the risk of injury from moving parts or electric shock. Always unplug the sprayer before servicing!

1. Unplug the sprayer.
2. Loosen and remove the four electronic pressure control (EPC) mounting screws.
3. Pull back the EPC for access to the electrical box.
4. Using a 3/8" metal drill bit, drill a hole through the bottom of the electrical box.
5. Insert the supplied rubber grommet into the hole in the electrical box.

NOTE: Some sprayers may have a small vent hole on the bottom of the electrical box. This hole can be used for the antenna instead of drilling a new one.

6. Thread the antenna wire through the grommet from inside the electrical box. The 2-pin male connector on the antenna wire should be inside the electrical box.

NOTE: Approximately 8-10 inches of antenna wire should hang from the bottom of the electrical box. Make sure there are no metal obstacles near the antenna besides the sprayer's stand or cart.

7. Locate the potentiometer inside the electrical box.

8. Unplug the potentiometer wires' 3-pin female connector from the EPC board (refer to the electrical schematic in the Parts List section of the sprayer manual).
9. Plug the potentiometer wires into the 3-pin male connector on the receiver.
10. Plug the receiver wire into the 3-pin male connector on the EPC board from which the potentiometer wires' connector was removed.
11. Plug the antenna wire into the 2-pin female connector on the receiver.
12. Using the supplied double-sided tape, secure the receiver to the top internal wall of the electrical box.
13. Position the EPC over the electrical box. Secure the EPC with the four EPC mounting screws.

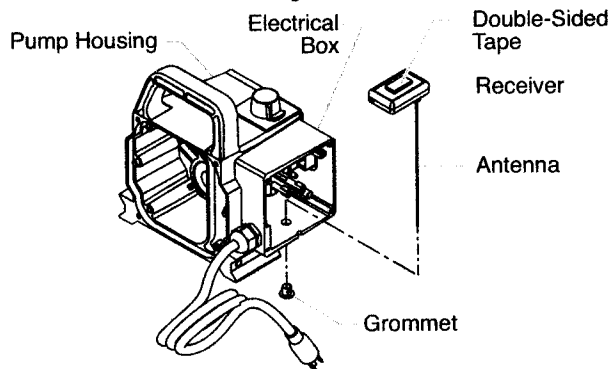

Titan 740i, 840i, and 1140i Sprayers

The receiver is installed on the top of the electronic control assembly on large Titan sprayers.

WARNING

Before proceeding, follow the Pressure Relief Procedure outlined in the sprayer manual. Additionally, follow all other warnings to reduce the risk of injury from moving parts or electric shock. Always unplug the sprayer before servicing!

1. Unplug the sprayer.
2. Loosen and remove the four motor shroud screws. Remove the motor shroud.
3. Loosen and remove the three electronic cover screws. Lift the electronic cover off of the electronic control assembly on the motor.

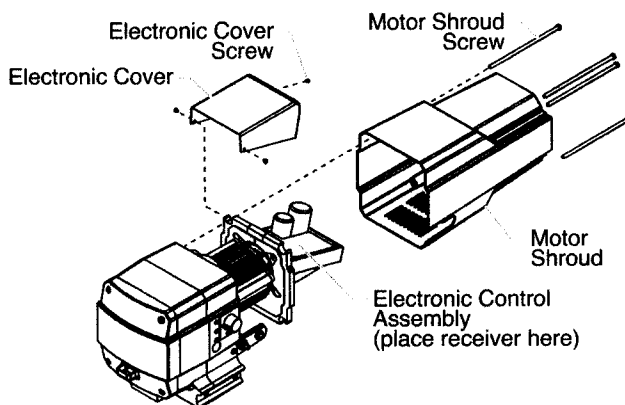

4. Unplug the potentiometer wires' 3-pin female connector from the electronic control assembly (refer to the electrical schematic in the Parts List section of the sprayer manual).

5. Using the supplied double-sided tape, secure the receiver to the top of the electronic control assembly.
6. Plug the potentiometer wires into the 3-pin male connector on the receiver.
7. Plug the receiver wires into the 3-pin male connector on the electronic control assembly from which the potentiometer wires' connector was removed.
8. Plug the jumper wire that is attached to the receiver wires into the 2-pin male connector that is diagonal from where the receiver wires are plugged in on the electronic control assembly.
 - a. If receiver installation is on a Titan 740i, make sure the jumper wire connector is plugged in so that the wire is in the position closest to the receiver wires.
 - b. If receiver installation is on a Titan 840i or 1140i, make sure the jumper wire connector is plugged in so that the wire is in the position furthest from the receiver wires.

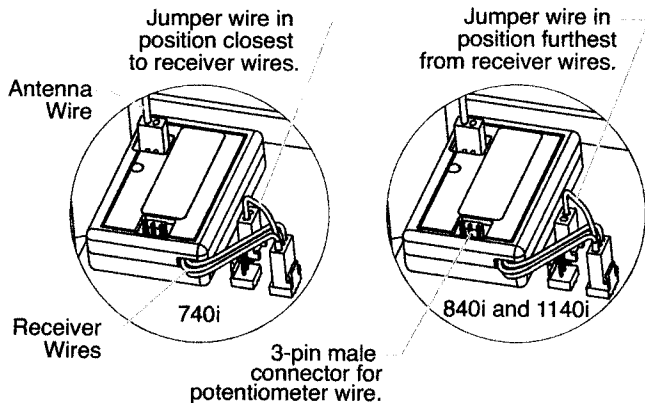

9. Plug the antenna wire into the black 2-pin female connector on the receiver.

10. Thread the antenna wire through one of the rear slots on the bottom of the motor shroud.

NOTE: Approximately 8–10 inches of antenna wire should hang from the bottom of the motor shroud. Make sure there are no metal obstacles near the antenna besides the sprayer's stand or cart.

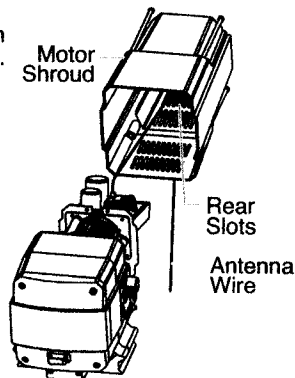

11. Position the electronic cover over the electronic control assembly. Secure the electronic cover with the three electronic cover screws.
12. Slide the motor shroud over the motor. Make sure the shroud gasket is positioned properly.
13. Secure the motor shroud with the four motor shroud screws.

Installing the Battery

The transmitter requires a 9V alkaline battery for operation. Use the following procedure to install the battery into the transmitter (refer to the Parts List section for illustrations).

1. Loosen and remove the two battery cover screws from the transmitter. Remove the battery cover.
2. Snap a 9V alkaline battery into the cap in the transmitter.
3. Replace the battery cover. Secure the battery cover to the transmitter with the two battery cover screws. Do not over-tighten the screws.

NOTE: Remove the battery from the transmitter during long-term storage.

Controls

The controls for the i-Remote are located on the transmitter.

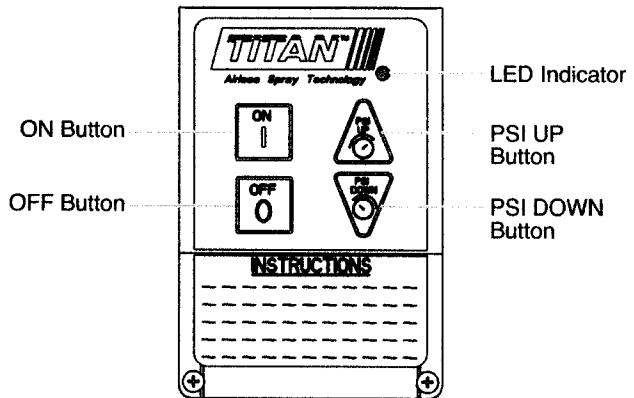

ON Button

Pressing the ON button will set the spraying pressure to the actual setting of the pressure control knob on the sprayer.

OFF Button

Pressing the OFF button will set the spraying pressure to 0 PSI.

WARNING

Pressing the OFF button on the transmitter will decrease the spraying pressure to 0 PSI only. The OFF button will not turn off the sprayer's power.

PSI UP Button

Pressing the PSI UP button will increase the spraying pressure by 50 PSI each time it is pressed.

PSI DOWN Button

Pressing the PSI DOWN button will decrease the spraying pressure by 100 PSI each time it is pressed.

LED Indicator

The LED indicator illuminates each time a button on the transmitter is pressed. This indicates that a signal is being sent from the transmitter.

Operation

Use the following procedures to operate the i-Remote.

Setting the Transmitter Address

Before the first time the i-Remote is used, the receiver must "learn" the transmitter address. This allows the receiver to receive signals from the transmitter and control the sprayer. The address is the digital code that the transmitter uses to send signals to the receiver.

NOTE: The transmitter address can be changed. Perform this procedure any time that the transmitter address is changed to allow the receiver to "learn" the new address.

1. Turn off the sprayer. Perform the Pressure Relief Procedure outlined in the sprayer manual.
2. Hold the transmitter within 2 feet of the sprayer to ensure good reception.
3. Turn on the sprayer.
4. Press the OFF button on the transmitter 3 times in a row within 15 seconds of turning on the sprayer. The receiver now knows the transmitter address.

NOTE: The OFF button must be pressed within 15 seconds of turning on the sprayer. If it is not, the receiver will not be able to "learn" the transmitter address and the above procedure must be repeated.

Using the i-Remote

1. Set up and turn on the sprayer using the procedures outlined in the sprayer's Owner's Manual.
2. Move the pressure control knob on the sprayer to the desired initial pressure setting. Use the procedures outlined in the sprayer's Owner's Manual to set the initial pressure.

NOTE: Changing the setting of the pressure control knob on the sprayer after using the i-Remote will reset the spraying pressure. Movement of the pressure control knob overrides the settings of the i-Remote. This allows the sprayer to function normally without the i-Remote.

3. Begin spraying. Adjust the spraying pressure to the desired setting by pressing the ON, OFF, PSI UP, or PSI DOWN buttons on the transmitter. Refer to the Controls section of this manual for the function of each button.

NOTE: The i-Remote is designed to operate at distances up to 100 feet. The surrounding area, obstacles, and battery life all will affect the operation of the i-Remote. If reception problems occur, point the transmitter in a different direction or move closer to the sprayer. If the operational distance of the i-Remote decreases dramatically, replace the battery in the transmitter.

4. When spraying is complete, turn off the sprayer using the procedures outlined in the sprayer's Owner's Manual.

WARNING

Pressing the OFF button on the transmitter will decrease the spraying pressure to 0 PSI only. The OFF button will not turn off the sprayer's power.

Changing the Transmitter Address

The default transmitter address set by the factory can be used in most cases. If a problem occurs where there is interference from another transmitter in the area, the transmitter address should be changed.

1. Loosen and remove the two battery cover screws from the transmitter. Remove the battery cover.
2. Remove the battery from the transmitter.

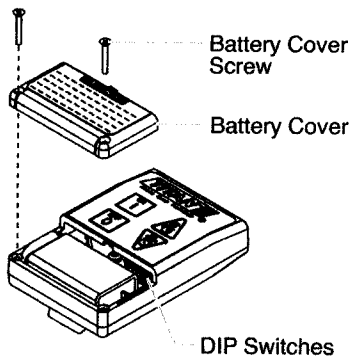

3. Locate the DIP switches on the circuit board.
4. Using a pen or similar tool, change one of the switch positions.
5. Snap the battery back into the cap in the transmitter.
6. Replace the battery cover. Secure the battery cover to the transmitter with the two battery cover screws. Do not over-tighten the screws.
7. Perform the "Setting the Transmitter Address" procedure.

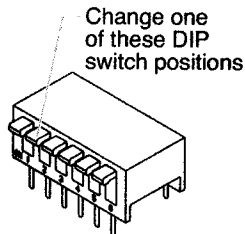

Parts List

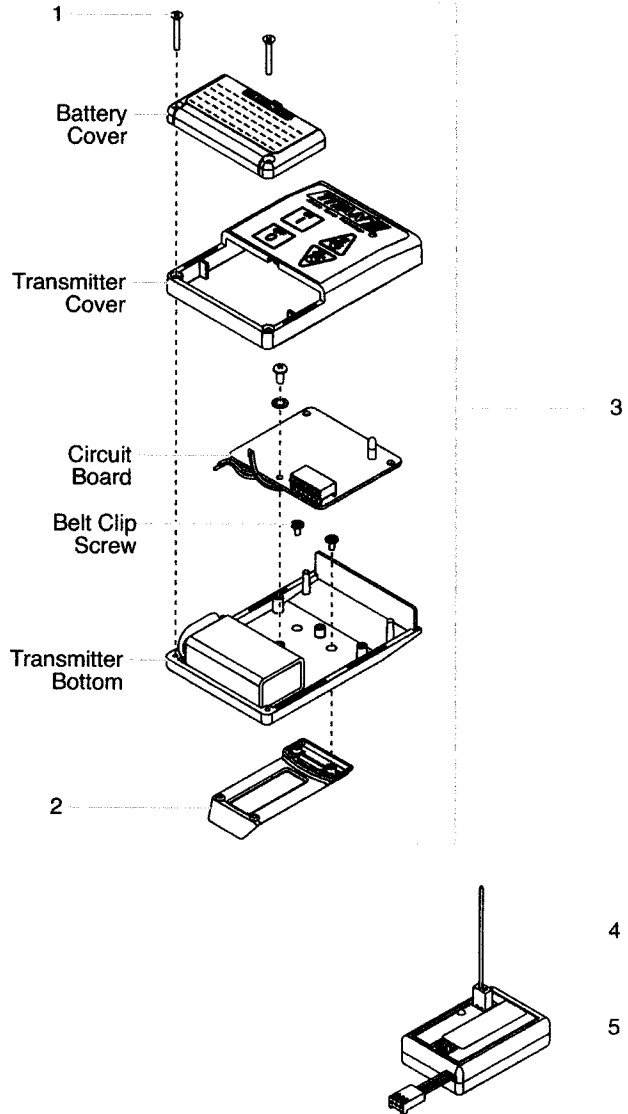

Item	Part #	Description	Quantity
1	800-678	Battery cover screw.....	2
2	800-676	Belt clip (includes belt clip screws)	1
3	800-691	Transmitter	1
4	800-687	Antenna	1
5	800-692	Receiver (includes item 4).....	1

NOTE: For help installing the i-Remote into electronically-controlled sprayers not covered by this manual, contact Titan Technical Service at 1-800-526-5362.

Limited Warranty

Titan Tool, Inc., ("Titan") warrants that at the time of delivery to the original purchaser for use ("End User"), the equipment covered by this warranty is free from defects in material and workmanship. Titan's obligation under this warranty is limited to replacing or repairing without charge those parts which, to Titan's reasonable satisfaction, are shown to be defective within twelve (12) months after sale to the End User. This warranty applies only when the unit is installed and operated in accordance with the recommendations and instructions of Titan.

This warranty does not apply in the case of damage or wear caused by abrasion, corrosion or misuse, negligence, accident, faulty installation, substitution of non-Titan component parts, or tampering with the unit in a manner to impair normal operation.

Defective parts are to be returned to an authorized Titan sales/service outlet. All transportation charges, including return to the factory, if necessary, are to be borne and prepaid by the End User. Repaired or replaced equipment will be returned to the End User transportation prepaid.

THERE IS NO OTHER EXPRESS WARRANTY. TITAN HEREBY DISCLAIMS ANY AND ALL IMPLIED WARRANTIES INCLUDING, BUT NOT LIMITED TO, THOSE OF MERCHANTABILITY AND FITNESS FOR A PARTICULAR PURPOSE, TO THE EXTENT PERMITTED BY LAW. THE DURATION OF ANY IMPLIED WARRANTIES WHICH CANNOT BE DISCLAIMED IS LIMITED TO THE TIME PERIOD SPECIFIED IN THE EXPRESS WARRANTY. IN NO CASE SHALL TITAN LIABILITY EXCEED THE AMOUNT OF THE PURCHASE PRICE. LIABILITY FOR CONSEQUENTIAL, INCIDENTAL OR SPECIAL DAMAGES UNDER ANY AND ALL WARRANTIES IS EXCLUDED TO THE EXTENT PERMITTED BY LAW.

TITAN MAKES NO WARRANTY AND DISCLAIMS ALL IMPLIED WARRANTIES OF MERCHANTABILITY AND FITNESS FOR A PARTICULAR PURPOSE WITH RESPECT TO ACCESSORIES, EQUIPMENT, MATERIALS OR COMPONENTS SOLD BUT NOT MANUFACTURED BY TITAN. THOSE ITEMS SOLD, BUT NOT MANUFACTURED BY TITAN (SUCH AS GAS ENGINES, SWITCHES, HOSES, ETC.) ARE SUBJECT TO THE WARRANTY, IF ANY, OF THEIR MANUFACTURER. TITAN WILL PROVIDE THE PURCHASER WITH REASONABLE ASSISTANCE IN MAKING ANY CLAIM FOR BREACH OF THESE WARRANTIES.

Instruction to the User

This equipment has been tested and found to comply with the limits for a class B digital device, pursuant to part 15 of the FCC Rules. These limits are designed to provide reasonable protection against harmful interference in a residential installation. This equipment generates, uses and can radiate radio frequency energy and if not installed and used in accordance with the instructions, may cause harmful interference to radio communications. However, there is no guarantee that interference will not occur in a particular installation. If this equipment does cause harmful interference to radio or television reception, which can be determined by turning the equipment off and on, the user is encouraged to try to correct the interference by one or more of the following measures:

- Reorient or relocate the receiving antenna.
- Increase the separation between the equipment and receiver.
- Connect the equipment into an outlet on a circuit different from that to which the receiver is connected.
- Consult the dealer or an experienced radio/TV technician for help.

This equipment has been certified to comply with the limits for a class B computing device, pursuant to FCC Rules. In order to maintain compliance with FCC regulations, shielded cables must be used with this equipment. Operation with non-approved equipment or unshielded cables is likely to result in interference to radio and TV reception. The user is cautioned that changes and modifications made to the equipment without the approval of manufacturer could void the user's authority to operate this equipment.

The term "IC:" before the certification/registration number only signifies that the Industry Canada technical specifications were met.

Operation is subject to the following two conditions: (1) this device may not cause interference, and (2) this device must accept any interference, including interference that may cause undesired operation of the device.



United States Sales & Service

1-800-526-5362

Fax 1-800-528-4826

556 Commerce Street
Franklin Lakes, NJ 07417

www.titantool.com

Canadian Branch

1-800-565-8665

Fax 1-905-856-8496

200 Trowers Road, Unit 7B
Woodbridge, Ontario L4L 5Z8

International

1-201-337-1240

Fax 1-201-405-7449

556 Commerce Street
Franklin Lakes, NJ 07417 USA