



LIFTING SOLUTIONS

www.trimble.com/liftingsolutions

MBR105 Cab Mounted Display

Installation and Operation Manual



ENGLISH

MBR105_ENG_rev0.4

TABLE OF CONTENTS

1: GENERAL	3	5: CERTIFICATION NOTES.....	12
1.1 Introduction	3	5.1 FCC and IC—Instructions to the User	12
1.2 About This Manual	3	5.2 CE	13
1.2a Notifications Included in Document.....	3	5.2a Declaration of Conformity	13
1.2b How To Provide Feedback To Trimble Lifting Solutions	3	5.2b CE Safety.....	14
1.2c How This Manual Is Updated.	3		
1.2d How to Contact Trimble Lifting Solutions. .	3	6: LIMITED WARRANTY	15
1.3 Recommended Operating Conditions	3	NOTES	16
1.4 Powering Up	3	REVISION HISTORY	18
1.5 Before You Begin	3		
2: ANTENNA AND INSTALLATION OVERVIEW.....	4		
2.1 Mounting Bracket	4		
2.2 Antenna Position	4		
2.3 Power Supply and Lockout Connection ...	4		
2.4 Power Supply Verification	5		
2.5 Cleaning Instructons	5		
2.6 Supported Sensor Type	5		
3: BUTTON AND ICON DEFINITION.....	6		
3.1 Button Definition	6		
3.2 Icon Definition	6		
4: DISPLAY AND MENU OVERVIEW	7		
4.1 Display Abbreviations	7		
4.2 Menu Outline	7		
4.3 Symbol Overview	8		

1: GENERAL

1.1 Introduction

The MBR105 is explained as follows:

The system includes the cab mounted MBR105 radio display and compatible Trimble Lifting Solutions sensors. The MBR105 creates a two-way radio network with the sensors to bring required data to the operator. The MBR105 has a user-adjustable limit and will generate an alarm when this limit is reached.

1.2 About This Manual

This installation and operation manual describes how to install, operate and maintain the MBR105.

1.2a Notifications Included in Document

The following notations may be used in this manual:

NOTE

HINTS AND TIPS TO FACILITATE SYSTEM INSTALLATION OR UNDERSTANDING.

CAUTION

PROTECT YOURSELF AGAINST PRODUCT PERFORMANCE ISSUES, PRODUCT FAILURE, AND/OR PROPERTY DAMAGE.

WARNING

*PROTECT YOURSELF AGAINST **SERIOUS INJURY OR DEATH.***

1.2b How To Provide Feedback To Trimble Lifting Solutions

Trimble Lifting Solutions welcomes your feedback on the accuracy and effectiveness of this document. Please send feedback to doc@loadsystems.com. Please include the title of the manual and version (this information is located in the Document's Revision History on page 18) with your feedback.

1.2c How This Manual Is Updated

Trimble Lifting Solutions will issue new releases of this manual as new material becomes available. Refer to the Document Revision History on page 18 of the manual for more information.

1.2d How to Contact Trimble Lifting Solutions

Please contact Trimble Lifting Solutions if you encounter problems or require advice. Contact details are located on the back cover.

1.3 Recommended Operating Conditions

Supply Voltage	9 to 30 Vdc
Current Requirements	Maximum 2 amperes
Output Wire Voltage	0 Vdc or supply voltage -1.5 Vdc
Output Wire Current Capability	0.7 amperes, 1A nominal trip current
Operating Temp.	5°F to 122°F (-15°C to +50°C)
Maximum Altitude	16,400 ft (5,000 m)
Relative Humidity	95% Maximum
Usage	Outdoor Wet Location
Pollution Degree	3

1.4 Powering Up

On power up, the display will show six horizontal lines and the antenna symbol will flash. Once a reliable radio communication network is established, the antenna symbol will remain lit without flashing. If the antenna symbol flashes continuously, the MBR105 may not be correctly programmed. To correctly program the MBR105, follow the How to Add a Sensor procedure on page 9, Section 4.3, number 6.

1.5 Before You Begin

WARNING

THE MBR105 SYSTEM IS DESIGNED AS AN OPERATOR AID AND IS IN NO WAY A SUBSTITUTE FOR SAFE OPERATING PRACTICES.

WARNING

CAREFULLY READ AND UNDERSTAND THIS MANUAL BEFORE PROCEEDING.

WARNING

INSTALLATION MUST BE MADE IN COMPLIANCE WITH TRIMBLE LIFTING SOLUTIONS INSTRUCTIONS AND USING TRIMBLE LIFTING SOLUTIONS SUPPLIED COMPONENTS ONLY. FAILURE TO INSTALL ALL PARTS OR REPLACING PARTS OR COMPONENTS WITH PARTS OR COMPONENTS NOT SUPPLIED BY TRIMBLE LIFTING SOLUTIONS MAY LEAD TO SYSTEM FAILURE, SERIOUS INJURY OR DEATH.

2: ANTENNA AND INSTALLATION OVERVIEW

NOTE

HOLD BYPASS/EXIT TO TEMPORARILY BYPASS CRANE FUNCTION LOCKOUT CAUSED BY A MISSING SENSOR OR AN ALARM CONDITION

CAUTION

DO NOT CRACK OR PUNCTURE THE MEMBRANE FASCIA. THE MBR105 DISPLAY IS SPLASH PROOF. WATERPROOFING DEPENDS, IN PART, ON THE INTEGRITY OF THE MEMBRANE.

CAUTION

DO NOT POWER WASH THE DISPLAY. THE MBR105 DISPLAY IS NOT DESIGNED TO WITHSTAND HIGH-PRESSURE WASHING DEVICES THAT CAN ERODE THE MEMBRANE FASCIA SEAL OR CREATE FISSURES IN THE MEMBRANE FASCIA. POWER WASHING THE DISPLAY VOIDS WARRANTY COVERAGE.

CAUTION

THE EQUIPMENT IS TO BE SERVICED BY MANUFACTURER ONLY.

Drill 5/16-inch (7 mm) clearance holes through the mounting surface with 1/4-inch (6 mm) bolt following either the two-, three- or the four-hole configuration.

Install the display with bolts. Add washers and lock nuts behind the mounting surface and tighten sufficiently (bolts, nuts and washers not included).

NOTE

IF THE NUTS ARE ON THE OUTSIDE OF THE CAB, CAULK WITH SILICONE BETWEEN THE WASHERS AND THE CAB TO PREVENT WATER ENTRY.

Loosen the thumb screw of the bracket arm to adjust display orientation to facilitate viewing by operator and then tighten it back up.

2.2 Antenna Position

The MBR105 antenna is located in the lid. For optimal performance, the MBR105 should be used with the lid fully open to 180°.

1. The antenna should have 5 inches (127 mm) of clear space all around it. The RAM mount is approximately 4 inches (102 mm).
2. The antenna should have an unobstructed line of sight with the sensor.

CAUTION

DO NOT FORCE THE LID BEYOND ITS FULLY OPEN POSITION.

2.3 Power Supply and Lockout Connection

1. Connect the black wire (ground) to the negative terminal of the battery or the panel connection; alternatively, bolt the black wire to the body of the machine with a 1/4-inch (6 mm) or 5/16-inch (7 mm) bolt. The ground connection must be strong enough to sustain two amperes.
2. Connect the brown wire to a fused accessory source, rated at least two amperes, that supplies +12 or +24 volts when the machine is in use. The MBR105 will automatically detect the voltage level and adjust itself.

2.1 Mounting Bracket

Determine the mounting location; the display must be installed inside the cab. It can be mounted on the dash, on a sidewall or on the ceiling of the cab. To ensure reliable radio communication between the sensor and the MBR105, the flip must be opened, not in contact with metal and should have a direct and clear line of sight to the sensor antenna. The mounting bracket requires a flat surface of at least 2.5 inches (64 mm) in diameter on both sides and where the back of the surface is accessible in order to tighten the nuts.

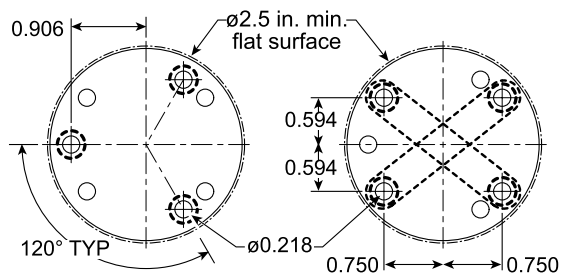

Display mounting bracket footprint. Not to scale.

3. Lockout wire (if required): connect the blue wire to a Bosch relay coil terminal. Connect the other coil terminal of the relay to the ground. When in safe condition, the blue wire will energize at the battery positive level.
4. Any current greater than the trip current (1A nominal) triggers an auto re-settable fuse. Current will resume flowing several seconds after the short circuit is eliminated.

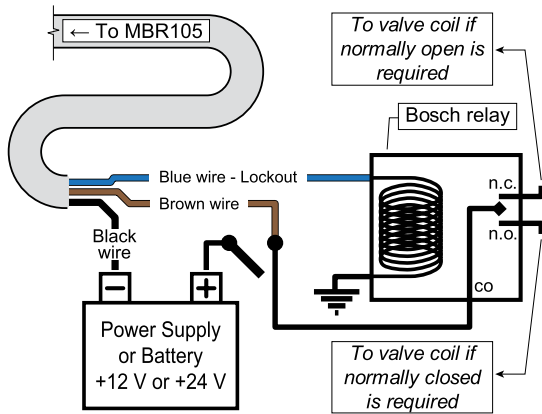

Connection with blue wire lockout and recommended Bosch relay.

CAUTION

INVERTING THE MBR105 WIRING MAY CAUSE DAMAGE TO THE PRODUCT.

The MBR105 will engage lockout and audible alarm when the lid is closed.

2.4 Power Supply Verification

The power from the crane needs to be checked in the DC and AC modes under the following conditions:

- Engine start-up
- Engine idling
- Engine revving up, during complete process (not just when it is revved up)
- Engine revving down (same process as above)
- Engine shut-down

The DC power should not exceed 30 Vdc and the AC should be negligible (i.e., <1 Vac).

2.5 Cleaning Instructions

CAUTION

KEEP THE OUTER SURFACE FREE OF DIRT AND DUST.

To clean the device, wipe it with a clean dry cloth. Use caution when wiping the display area. The material can scratch easily.

You may use a mild soap and water solution on a damp microfiber cloth to clean outer surfaces (do not immerse in water).

2.6 Supported Sensor Type

GC Load Cells, GLC Load Cells, GS001-XX, GS010-XX, GS020, GS026, GS005, GS075-B, PT00100-XX, GS110 (Angle only), GS112 (Angle only), GS007-XX (Line Rider Tx/Rx).

3: BUTTON AND ICON DEFINITION

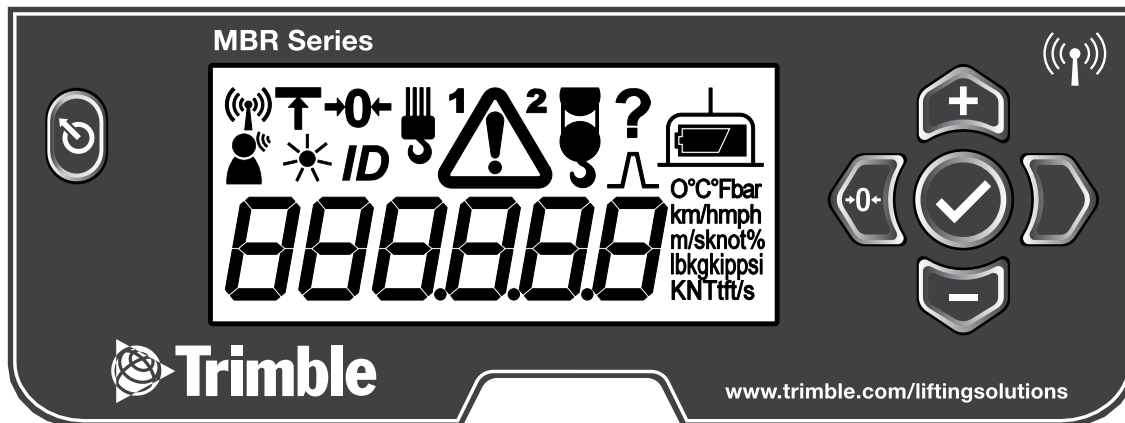



3.1 Button Definition

- 

Bypass / Exit
The lockout will be bypassed and the alarm will remain silent until the button is released. / Exit menu.
- 

Up
Modify numeric values and move up through sub menus.
- 

Down
Modify numeric values and move down through sub menus.
- 

Tare / Back
Tare the hook and rigging weight, zero the rope payout. / Move to the previous menu or digit.
- 

Next
Move to the next menu or digit.
- 

Menu / Enter
Access the system menus. / Enter entry, confirm changes to the system settings.

3.2 Icon Definition

- 

Communication Status Icon will blink when the communication with a sensor is not established.
- 

Limit Icon is displayed when a sensor limit is reached or while in the limit menu.
- 

Tare Icon is displayed when a tare is applied on a load sensor.
- 

Listen Only Mode Icon is displayed while in listen only mode or when in the network menu. (0: network controller; 1: listen only mode)
- 

Backlight Icon is displayed while in the backlight menu. (0: backlight off - the backlight will come on for four seconds when any button is pressed; 1: backlight on constantly when cover is open)
- 

ID Icon is displayed while in the sensor list menu. In a system where one A2B is installed with another sensor, the 1 and 2 icons indicate which sensor ID is active for editing.
- 

Part of Line Icon is displayed while in the parts of line adjustment menu.
- 

Warning Icon is displayed when a sensor limit is reached. In a system where one A2B is installed with another sensor, the 1 and 2 icons indicate which sensor is in alarm.
- 

Two-Block Icon is displayed when an A2B is programmed.
- 

Info Menu Icon is displayed in the info menu. Information on display ID, firmware PN and version and frequency is available.
- 

Max Peak Icon is displayed when the maximum load value is displayed.
- 

Battery Status Icon shows display battery status: good or change/recharge. (MBR100 only)
- 

Sensor Battery Level Icon blinks when the sensor battery is low.

4: DISPLAY AND MENU OVERVIEW

4.1 Display Abbreviations

°C	Celsius
°F	Fahrenheit
bar	Bar
Psi	Pounds per square inch
km/h	Kilometers per hour
mph	Miles per hour
m/s	Meters per second
knot	Knot

lb	Pound
kg	Kilogram
kip	Kip (1000 lb)
kN	Kilonewton
T	Short ton
t	Metric ton (tonne)
m	Meter
ft	Feet

4.2 Menu Outline

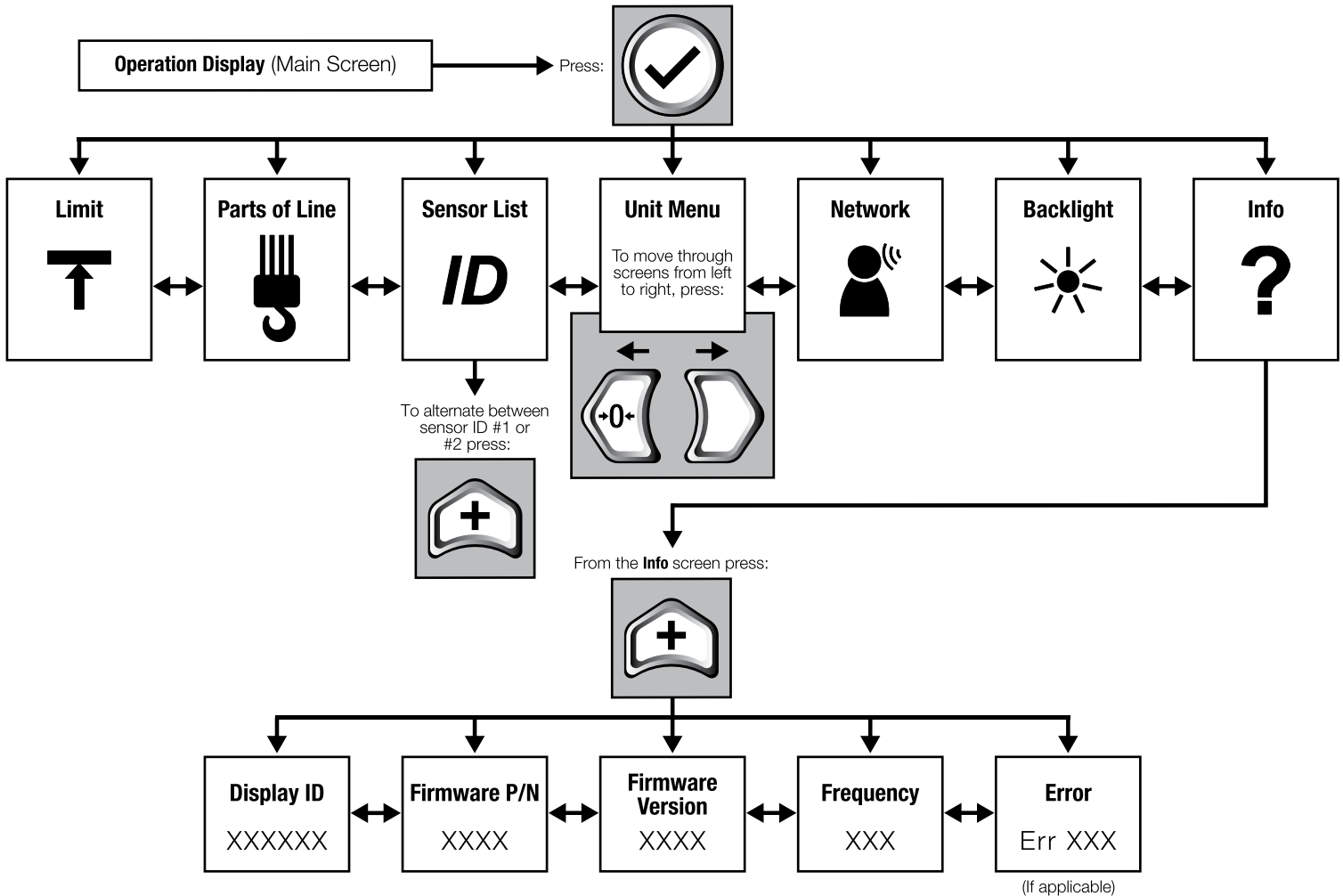

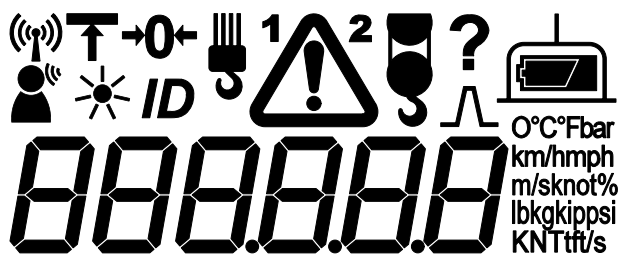

LCD Screen

4.3 Symbol Overview

1. Communication Status

The communication status icon appears when a sensor is programmed in the MBR105. The icon stays on when the MBR105 has a reliable radio communication link to all programmed sensors. The icon blinks when communication with any programmed sensor is not established.

2. Network Options

Network Controller

When the MBR105 is powered up it normally wakes up all sensors programmed in the sensor list and takes control of them. If a second display is powered up with one or more of the same sensors programmed in the sensor list, then the second display will take control of those sensors; the sensors will no longer acknowledge communication from the first display.

Listen Only Mode



When the MBR105 is programmed to operate in listen only mode, it displays the information from programmed sensors without becoming the network controller.



CAUTION





SENSORS CAN ONLY HAVE ONE NETWORK CONTROLLER AT A TIME. TO RECEIVE COMMUNICATION FROM A SENSOR WITHOUT TAKING CONTROL OF THAT SENSOR, A DISPLAY MUST FIRST BE PROGRAMMED IN LISTEN ONLY MODE.

Program the *Listen Only Mode*:

1.  Go to the menu.
2.  Press Next to go to the Network Options menu.







3.  Press Enter to edit value.
4.  Use Up and Down to program the Network Option mode:

Network Controller	0
Listen Only Mode	1

5.  Press Enter to save the new network path.
6.  Press Exit to return to the operation display.





3. Limit

To change the limit of a programmed sensor:



1.  Go to the menu.
2.  Press Next until the Limit icon is displayed.
3.  Press Enter to edit value.
4.  Use Up, Down, Back and Next to select a digit and program the limit.
5.  Press Enter to save any changes made to the limit.
6.  Press Exit to return to the operation display.

4. Backlight Mode

The LCD backlight can be always on, or on a four-second timer, following a keypad entry. To adjust the backlight mode:

1.  Go to the menu.
2.  Press Next until the Backlight icon is displayed.
3.  Press Enter to edit value.
4.  Use Up and Down to set the value:



Four-second timer	0
Always on	1

5.  Press Enter to save the new backlight mode.
6.  Press Exit to return to the operation display.

5. Tare 

Tare is used to zero the hook and rigging weight on a load sensor or to zero the rope payout value.

Load Sensor

If the tare icon is not displayed, press the Tare button  to create a tare value equal to the weight on the load sensor. Example: With hook block and rigging only. Load display is net weight (gross weight minus tare value). To remove a tare value, press the Tare button. 

	LCD Indicator	LCD Load
No Tare Value	(none)	Gross Weight
Tare Value		Net Weight









Zero Rope Payout (Length)

Press the Tare button  to zero the rope payout length. The new zero will be saved by the rope payout sensor.

6. ID *ID*

The sensor in the MBR105 system is programmed in the ID menu.

To add a sensor:

1.  Go to the menu.
2.  Press Enter to edit value.
3.     Use Up, Down, Back and Next to select a digit and program the sensor ID.
4.  Press Enter to save any changes made to the sensor ID.
5.  Press Exit to return to the operation display.

When an A2B is installed, it is possible to install a second sensor. In such a case, press  while the ID menu is displayed to access the second ID.









7. Part of Line 

The load sensor often shares the weight with multiple parts of line. For accurate load indication the MBR105 must be programmed for the number of parts of line.

NOTE







THE PART OF LINE MENU OPTION IS ONLY AVAILABLE WHEN A LOAD SENSOR ID IS PROGRAMMED IN THE DISPLAY.



To set the number of parts of line:

1.  Go to the menu.
2.  Use Next to go to the part of line where the  icon is displayed.
3.  Press Enter to edit value.
4.   Use Up and Down to select the parts of line.
5.  Press Enter to save any changes made to parts of line.
6.  Press Exit to return to the operation display.

8. Unit and Sensor Function Selection

To change the sensor unit or to change the sensor function, the MBR105 must be in communication with the sensor programmed.

1.  Go to the menu.
2.  Use Next to go to the unit menu where a one digit number and the current units are displayed.
3.  Press Enter to edit value.
4.   Use Up and Down to scroll through the available units.*
5.  Press Enter to save the change.
6.  Press Exit to return to the operation display.

* Some sensors include more than one sensing function (ex: a wind sensor provides both wind speed and wind gust information). The MBR105 indicates data from one sensing function only. The function to be indicated can be selected when selecting the indication units. The digit indicates the sensor function to be indicated. Once all the units available for the first sensor function have been passed, the units available for the next sensor function can be selected. For example, to select wind gust indication by a wind sensor, scroll with Up  or Down  in the unit selection menu until the number 2 is indicated along with the desired units.

9. Alarm 

The sensor programmed will generate an audible alarm when the alarm level is reached. Alarm will also generate a warning icon on the LCD.

Hold Bypass  to momentarily silent the alarm.

10. A2B 

The MBR105 supports one or two wireless

anti-two-block switches. The  icon is displayed on the LCD to indicate that at least one A2B is programmed in the MBR105. When a two-block is detected, the warning icon appears on the LCD. The number above indicates which sensor

is in alarm. 

11. Information ?

Standard Info menu pages include:

1. Display ID
2. Firmware Number
3. Firmware Version
4. Display Frequency
5. Error Code(s) – If Applicable

List of possible error codes:

Error Code	Description
100	The display is not receiving communication from the sensor. Action: Verify that the programmed sensor ID number matches the ID number of the programmed sensor.
102	Battery life in the sensor is low.
103	The sensor indicates a value greater than the operator adjusted limit (maximum limit alarm) or the sensor indicates a value less than the operator adjusted limit (minimum limit alarm).
104	Slew faulty cable. Action: Contact Trimble Lifting Solutions.
105	Slew faulty magnet. Action: Contact Trimble Lifting Solutions.
106	Slew faulty magnet. Action: Contact Trimble Lifting Solutions.
107	Slew encoder error. Action: Contact Trimble Lifting Solutions.
108	Pressure transducer faulty cable. Action: Verify that the cable is not damaged or disconnected.
109	Pressure transducer over pressure. System pressure exceeds the pressure transducer maximum pressure.
110	Pressure transducer bad signal. Action: Contact Trimble Lifting Solutions.
111	Pressure transducer bad signal. Action: Contact Trimble Lifting Solutions.
112	Wind sensor fault. Action: Verify sensor battery.
113	Sensor not calibrated. It is not possible to calibrate a sensor from the MBR105, another Trimble Lifting Solutions display must be used.
114	Sensor needs position confirmation. It is not possible to confirm the sensor position from the MBR105, another Trimble Lifting Solutions display must be used.
115	Sensor maximum capacity exceeded.
116	Minimum strain gauge value. Action: Contact Trimble Lifting Solutions.
117	Maximum strain gauge value. Action: Contact Trimble Lifting Solutions.
118	Lockout overcurrent condition. (MBR105 only)
119	Radio module faulty. Action: Contact Trimble Lifting Solutions.
120	Sensor not supported. Action: Use supported sensor type.



12. Maximum Peak

NOTE

THE MAXIMUM PEAK MENU OPTION IS ONLY AVAILABLE WHEN A LOAD SENSOR ID IS PROGRAMMED IN THE DISPLAY.

When the MBR105 is programmed with a load sensor, the highest load value received is stored in local memory by default.

When the MBR105 is powered down, the maximum value is lost.

To visualize the current maximum peak, hold the Next button  and press the Tare button. 

The  icon indicates that value displayed is the maximum peak.

A release of the keys will exit the maximum value screen and return to “live load” values.

To reset the maximum value, press the Exit button  while the maximum peak is displayed.

13. Low Sensor Battery

The sensor icon flashes when one of the programmed sensors' battery life is low.

5: CERTIFICATION NOTES

5.1 FCC and IC—Instructions to the User

This equipment has been tested and found to comply with the limits for a class B digital device, pursuant to part 15 of the FCC Rules. These limits are designed to provide reasonable protection against harmful interference in a residential installation. This equipment generates, uses, and can radiate radio frequency energy and if not installed and used in accordance with the instructions, may cause harmful interference to radio communications. However, there is no guarantee that interference will not occur in a particular installation. If this equipment does cause harmful interference to radio or television reception, which can be determined by turning the equipment off and on, the user is encouraged to try to correct the interference by one or more of the following measures:

- Reorient or relocate the receiving antenna.
- Increase the separation between the equipment and receiver.
- Connect the equipment into an outlet on a circuit different from that to which the receiver is connected.
- Consult the dealer or an experienced radio/TV technician for help.

FCC ID: QVMBR001 IC: 7076A-ICMBR001

RF Exposure Warning:

The MBR105 complies with FCC/IC radiation exposure limits set forth for an uncontrolled environment. To comply with RF exposure requirements, the unit must be installed and operated with 0.8 in (2 cm) or more between the antenna (located inside the lid) and your body. This product may not be collocated or operated in conjunction with any other antenna or transmitter.

This device complies with Industry Canada licence-exempt RSS standard(s). Operation is subject to the following two conditions: (1) this device may not cause interference, and (2) this device must accept any interference, including interference that may cause undesired operation of the device.

Changes or modifications not expressly approved by the party responsible for compliance could void the user's authority to operate the equipment.

FCC ID: QVBGS000 IC: 7076A-ICGS000

RF Exposure Warning:

Trimble Lifting Solutions sensors comply with FCC/IC radiation exposure limits set forth for an uncontrolled environment. To comply with RF exposure requirements, the unit must be installed and operated with 8 in (20 cm) or more between the product and your body. This product may not be collocated or operated in conjunction with any other antenna or transmitter.

This device has been designed to operate with the antennas listed below, and having a maximum gain of 3.0 dB. Antennas not included in this list or having a gain greater than 3.0 dB are strictly prohibited for use with this device. The required antenna impedance is 50 ohms.

To reduce potential radio interference to other users, the antenna type and its gain should be so chosen that the equivalent isotropically radiated power (e.i.r.p.) is not more than that permitted for successful communication.

ANTENNA LIST

LSI-Robway P/N:	TA011
Description:	1/4 wave monopole
Manufacturer:	LSI-Robway

5.2 CE

5.2a Declaration of Conformity

Declaration of Conformity
According to EN 45014



Manufacturer's Name: Load Systems International Inc.
Manufacturer's Address: 2666 boul. du Parc Technologique, Suite 190
Québec, QC, Canada, G1P 2J7

declare under our own responsibility that the products:

<u>Model</u>	<u>Description</u>
MBR100-02	Portable display
MBR105-02	Cab mounted display

to which this declaration refers conform to the relevant standards or other standardising documents:

Safety: EN 61010-1:2010
Wireless: EN 300 220-2 V2.3.1
EMC: EN 301 489-1 V1.9.2
EN 301 489-3 V1.6.1

Québec, October 13th, 2015



Eric Beaulieu
Technologies Manager

Declaration of Conformity
According to EN 45014



Manufacturer's Name: Load Systems International Inc.

Manufacturer's Address:

Canada:
4495 Blvd. Wilfrid-Hamel, Suite 110
Québec, QC, Canada, G1P 2J7

United States of America:
9223 Solon, Suite A
Houston, TX 77064

United Arab Emirates:
Q3-171 SAIF Zone, P.O. Box 7976
Sharjah - UAE

declare under our own responsibility that the products:

Model	Description
GC005-CE, GC005-ATEX-CE	5 000 lb Capacity Load Cell
GC012-CE, GC012-ATEX-CE	12 000 lb Capacity Load Cell
GC018-CE, GC018-ATEX-CE	18 000 lb Capacity Load Cell
GC035-CE, GC035-ATEX-CE	35 000 lb Capacity Load Cell
GC060-CE, GC060-ATEX-CE	60 000 lb Capacity Load Cell
GC100-CE, GC100-ATEX-CE	100 000 lb Capacity Load Cell
GC170-CE, GC170-ATEX-CE	170 000 lb Capacity Load Cell
GS001-CE, GS001-ATEX-CE	Load Transmitter With Pigtail 6 in.
GS002-CE, GS002-ATEX-CE	Load Transmitter With Pigtail 6 in for balanced cell
GS005-CE, GS005-ATEX-CE	Anti-Two-Block Transmitter
GS010-XX-CE, GS010-XX-ATEX-CE	Angle Sensor
GS011-XX-CE, GS011-XX-ATEX-CE	Angle Sensor With Length Input
GS012-CE	Angle Length Sensor
GS020-CE, GS020-ATEX-CE	Wind Speed Sensor
GS035-CE	Pressure Transducer
GS050-CE, GS050-ATEX-CE	Anti-Two-Block Sensor
GS075-CE	All-In-One Anti-Two-Block Switch Weight
GS2XX-CE	LSI Wireless Gateway
GS320-CE	Stand Alone Wind Speed Display
GS375-CE	Stand Alone A2B Display
GS550-CE, GS550-ATEX-CE	Standard GS display
GS550-03-CE	Hand-Held GS display
GS550-XX-CE	OEM GS display
GS820-CE	Graphical GS display

to which this declaration refers conform to the relevant standards or other standardising documents:

- Safety:** IEC 61010-1: 2nd ed. (2001), EN 61010-1: 2nd ed. (2001)
- Wireless:** EN 300 220-3 V1.1.1 (2000-09)
- EMC:** EN 301 489-3 V1.4.1 (2002-08)

Québec, April 1st, 2010



Eric Beaulieu
Technologies Manager

5.2b CE Safety

WARNING



BURN HAZARD. DO NOT OPERATE THE MBR105 WHEN THE AMBIENT TEMPERATURE IS HIGHER THAN 50°C.

CAUTION



THE INGRESS PROTECTION RATING OF THE EQUIPMENT CORRESPONDS TO IP65. DO NOT OPERATE THE EQUIPMENT IN ENVIRONMENTAL CONDITIONS THAT EXCEED THE RATING.

WARNING



THE PROTECTION WILL BE IMPAIRED IF THE MATERIAL AND EQUIPMENT ARE USED IN A MANNER NOT SPECIFIED BY THE MANUFACTURER.

6: LIMITED WARRANTY

WARRANTY LENGTH	PRODUCT FAMILY
24 months	GC Series Load Cells, GD Series Line Riders, GP Series Load Pins GS001, GS002, GS003, GS004, GS005, GS007, GS010, GS011, GS012, GS020, GS030, GS031, GS035, GS050, GS075-B, GS101, GS106, GS110, GS112, GS220, GS221, GS222, GS224, GS550, GS820, LP Series Load Pins, LS051, LS055, PT00100
12 months	GS026, GS085, GS320, GS375, MBR100, MBR105
12 months*	All cabled products *Warranty duration for these Products may start from date of commissioning, provided a commissioning and calibration report is provided to us within six months of Delivery.

Please note that the Products are not intended for use in pile driving, wire rope activated clamshell or dragline applications, and any such use will be considered misuse of the Product and will exclude the Product from warranty coverage.

In connection with this limited warranty, we may require that we receive the data logging equipment used with the Products. You hereby authorize us to retrieve all information from such data logging equipment, which we may use, for example, in order to confirm compliance with written instructions and applicable standards, including safety margins. If we do not receive such information as requested, we shall have no obligations under this limited warranty. Costs associated with providing us with data logging equipment shall be borne by you.

If you request and we agree to provide attendance on site, you will pay our current applicable service rate for time on site, along with travel time from the nearest service center with the requisite capabilities, and fares and expenses.

In the event a Product is determined to be covered by this limited warranty, we will pay ground freight shipping fees of replacement or repaired parts or Products to the destination in the countries in which we maintain a service center for the applicable Products (currently Canada, continental United States of America, United Kingdom, Australia and the United Arab Emirates), but shipping fees for any other destination will be borne by you.

Detailed terms of the warranty are set forth at http://www.trimble.com/support/terms_of_sale.aspx, subject to the additional terms set forth above.

NOTES

Page left intentionally blank



www.trimble.com/liftingsolutions

**Technical support is available
24 hours a day, 7 days a week**

Isitech_support@trimble.com

USA

9633 Zaka Road
Houston, TX 77064
Toll Free Tel: +1.888.819.4355
Toll Free Fax: +1.888.238.4099
Tel: +1.281.664.1330
Fax: +1.281.664.1390
sales@loadsystems.com

AUSTRALIA

32 West Thebarton Road
Thebarton, South Australia 5031
Tel: +61 (0) 8.8238.3500
Fax: +61 (0) 8.8352.1684
sales@lsirobway.com.au

For technical support in the
Australia and Asia/Pacific region
please contact:
techsupport@lsirobway.com.au

UK

Unit 5, Silverfield House
Claymore Drive
Aberdeen Energy Park, Bridge of Don
Aberdeen AB23 8GD
Scotland, UK
Tel: +44 (0) 1224.392900
Fax: +44 (0) 1224.392920
uksales@loadsystems.com

DUBAI - UAE

Q3-171 SAIF Zone
PO Box 7976
Sharjah, UAE
Tel: 971.6.557.8314
Fax: 971.6.557.8315
Isifzc@emirates.net.ae

CANADA

PRODUCTION AND R&D

2666 boul. du Parc Technologique, Suite 190
Quebec City, QC, Canada G1P 4S6
Tel: +1.418.650.2330
Fax: +1.418.650.3340
sales@loadsystems.com