



**FCC/ISED Certification Test Report**  
**For the**  
**Frederick Energy Products LLC**  
**DDAC-PDS Magnetic Field Generator**

**FCC ID: QUI-DDAC-PDS**  
**ISED: 11625A-DDACPDS**

WLL JOB# 14653-01 Rev 2

September 30, 2016  
Revised January 6, 2017

Prepared for:

**Frederick Energy Products LLC**  
**1769 Jeff Road**  
**Huntsville, AL 35806**

Prepared By:

**Washington Laboratories, Ltd.**  
**7560 Lindbergh Drive**  
**Gaithersburg, Maryland 20879**



**Testing Certificate AT-1448**

**FCC/ISED Certification Test Report**  
**for the**  
**Frederick Energy Products LLC**  
**DDAC-PDS Magnetic Field Generator**

**FCC ID: QUI-DDAC-PDS**  
**ISED: 11625A-DDACPDS**

WLL JOB# 14653-01 Rev 2

**September 30, 2016**  
**Revised January 5, 2017**

Prepared by:



---

James Ritter  
Compliance Engineer

Reviewed by:



---

Steven D. Koster  
President

## Abstract

This report has been prepared on behalf of Frederick Energy Products LLC to support the attached Application for Equipment Authorization. The test report and application are submitted for a Transmitter under Part 15.209 (10/2014) of the FCC Rules and Regulations and ISED RSS-210 issue 9 (8/2016) and RSS-Gen issue 4 (11/ 2014). This Certification Test Report documents the test configuration and test results for the Frederick Energy Products LLC DDAC-PDS Magnetic Field Generator.

Testing was performed on an Open Area Test Site (OATS) of Washington Laboratories, Ltd, 7560 Lindbergh Drive, Gaithersburg, MD 20879. Site description and site attenuation data have been placed on file with the FCC's Sampling and Measurements Branch at the FCC laboratory in Columbia, MD. The ISED OATS numbers are 3035A-1 and 3035A-2 for Washington Laboratories, Ltd. Site 1 and Site 2, respectively. Washington Laboratories, Ltd. has been accepted by the FCC and approved by ANAB under Certificate AT-1448 as an independent FCC test laboratory.

The Frederick Energy Products LLC DDAC-PDS Magnetic Field Generator complies with the limits for a Transmitter device under FCC Part 15.209 and RSS210.

Revision History	Description of Change	Date
Rev 0	Initial Release	September 30, 2016
Rev 1	Corrected references to ISED documents	January 5, 2017
Rev 2	Added Extrapolation comments, corrected frequency error in tables 8 & 9.	January 6, 2017

**Table of Contents**

Abstract .....	ii
1 Introduction .....	1
1.1 Compliance Statement .....	1
1.2 Test Scope .....	1
1.3 Contract Information .....	1
1.4 Test Dates .....	1
1.5 Test and Support Personnel .....	1
1.6 Abbreviations .....	2
2 Equipment Under Test .....	3
2.1 Test Configuration .....	4
2.2 Equipment Configuration .....	5
2.3 Support Equipment .....	5
2.4 Interface Cables .....	5
2.5 EUT Modifications .....	6
2.6 Testing Algorithm .....	6
2.7 Test Location .....	6
2.8 Measurements .....	6
2.8.1 References .....	6
2.9 Measurement Uncertainty .....	6
3 Test Equipment .....	9
4 Test Results .....	10
4.1 Occupied Bandwidth: (FCC Part §2.1049, RSS –Gen sect 6.6) .....	10
4.2 Radiated Spurious Emissions: (FCC Part §15.209, RSS-Gen Table 6) .....	10
4.2.1 Test Procedure .....	10
4.3 Receiver Radiated Emissions (RSS-210 sect 2.5, RSS-GEN sect 6.1) .....	16
4.3.1 Requirements .....	16
4.3.2 Test Procedure .....	16
4.3.3 Test Data .....	16

**List of Tables**

Table 1: Device Summary.....	3
Table 2: Equipment Configuration .....	5
Table 3: Support Equipment .....	5
Table 4: Interface Cables .....	5
Table 5: Expanded Uncertainty List .....	8
Table 6: Test Equipment List.....	9
Table 7: Radiated Emissions Limits .....	10
Table 8: Extrapolation Table .....	11
Table 9: Fundamental Levels .....	13
Table 10: Radiated Emissions Test Data < 30MHz.....	14
Table 11: Radiated Emissions Test Data > 30MHz (TX and RCV).....	15
Table 12: Receiver Radiated Emissions Test Data > 30MHz (TX and RCV).....	18

**List of Figures**

Figure 1: Test Configuration.....	4
-----------------------------------	---

# 1 Introduction

## 1.1 Compliance Statement

The Frederick Energy Products LLC DDAC-PDS Magnetic Field Generator complies with the limits for an Intentional Radiator device under Part 15.209 of the FCC Rules and Regulations and ISED RSS-210 issue 9 (RSS-GEN Issue 4).

## 1.2 Test Scope

Tests for radiated were performed. All measurements were performed in accordance with FCC part 15.209, IC RSS 210, RSS-GEN, & ANSI C63.10:2013. The measurement equipment conforms to ANSI C63.2 Specifications for Electromagnetic Noise and Field Strength Instrumentation.

## 1.3 Contract Information

Customer: Frederick Energy Products LLC  
1769 Jeff Drive,  
Huntsville, AL, 35806

Quotation Number: 69576D

PO Number 6877

## 1.4 Test Dates

Testing was performed on the following date(s): 9/26/2016-9/28/2016

## 1.5 Test and Support Personnel

Washington Laboratories, LTD

James Ritter

Customer Representative

David Estill, Ishmael Chigumira

## 1.6 Abbreviations

A	Ampere
Ac	alternating current
AM	Amplitude Modulation
Amps	Amperes
b/s	bits per second
BW	Bandwidth
CE	Conducted Emission
Cm	centimeter
CW	Continuous Wave
dB	decibel
Dc	direct current
EMI	Electromagnetic Interference
EUT	Equipment Under Test
FM	Frequency Modulation
G	giga - prefix for $10^9$ multiplier
Hz	Hertz
IF	Intermediate Frequency
K	kilo - prefix for $10^3$ multiplier
M	Mega - prefix for $10^6$ multiplier
M	Meter
$\mu$	micro - prefix for $10^{-6}$ multiplier
NB	Narrowband
LISN	Line Impedance Stabilization Network
RE	Radiated Emissions
RF	Radio Frequency
Rms	root-mean-square
SN	Serial Number
S/A	Spectrum Analyzer
V	Volt

## 2 Equipment Under Test

The Frederick Energy Products LLC DDAC-PDS Magnetic Field Generator is a vehicle mounted that operates in conjunction with the Frederick Energy products PAD and other generator units. The DDAC-PDS Magnetic Field Generator produces a 73 kHz proximity field (certified in this report). When a user wearing a PAD unit enters this field it causes the PAD unit to visually and audibly alarm. In addition the PAD unit sends its serial number back to the Magnetic Field Generator (received on 916.49MHz) that causes the generator to visibly and audibly alarm.

The PAD unit is a separate transmitter already certified.

The generator device is typically mounted on a vehicle; the PAD units are worn by personnel to warn both the equipment operators and people in the proximity of this equipment of possibly dangerous conditions.

**Table 1: Device Summary**

ITEM	DESCRIPTION
Manufacturer:	Frederick Energy Products LLC
FCC ID:	QUI-DDAC-PDS
IC:	11625A-DDACPDS
EUT Name:	DDAC-PDS Magnetic Field Generator
Model:	DDAC-PDS
FCC Rule Parts:	15.209
ISED Rule Part	RSS210 issue 9 (RSS-Gen Issue 4)
ISED Emission Designator	NON
TX Frequency Range:	73kHz
RX Frequency Range	916.49MHz
Occupied Bandwidth:	N/A CW non modulated signal
Keying:	Automatic
Type of Information:	CW (illumination)
Number of Channels:	1
Power Output Level	Fixed
Antenna Type	Integral Magnetic Induction
Interface Cables:	Power, warning module cable
Power Source & Voltage:	Battery (13 VDC)
Highest TX emission	73kHz ,20uV/m @300m
Highest RX emission	86.34MHz, 69.2uV/m @3m, -3.2dB Margin



## 2.1 Test Configuration

The Frederick Energy Products LLC DDAC-PDS Magnetic Field Generator , Equipment Under Test (EUT), was operated from 12VDC via a Lab AC/DC power supply.

Note: The REMM Module option was also included. The device contains two Modular approved radio devices, Bluetooth Module RN4020 (FCC ID: T9JRN4020, IC: 6514A-RN4020) and Wi-Fi Module RN-131G (FCC ID: U30-G2M5477, 8169A-G2M5477). These radios do NOT transmit simultaneously and are located farther than 20cm from the Frederick energy radios

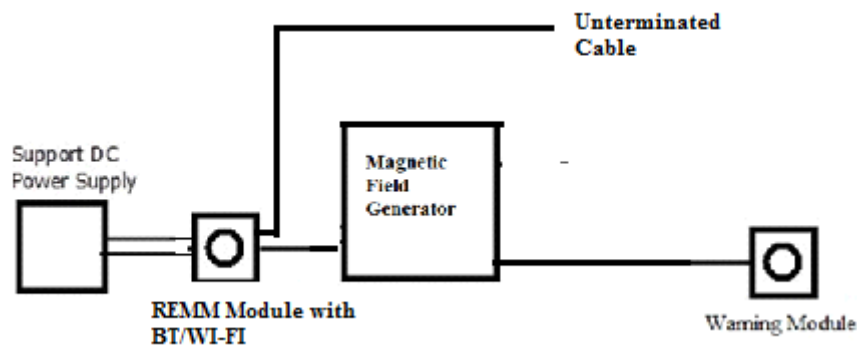

Figure 1: Test Configuration

## 2.2 Equipment Configuration

The EUT was set up as outlined in Figure 1. The EUT was comprised of the following equipment. (All Modules, PCBs, etc. listed were considered as part of the EUT, as tested.)

**Table 2: Equipment Configuration**

Name / Description	Manufacturer	Model	Serial Number	Revision
Frederick Energy Products LLC DDAC-PDS Magnetic Field Generator	Frederick Energy Products	DDAC-PDS	5	--
Warning Module	Frederick Energy Products	HN-WM-LO	WML002341	--
REM Module (optional)	Frederick Energy Products	DDAC-PDS-PTM	DDPTM000002	--

## 2.3 Support Equipment

The following support equipment was used during testing:

**Table 3: Support Equipment**

Item	Model/Part Number	Serial Number
PAD	HN-PAD-XL	PX00235
Power Supply (Primary)	1337DC Power Supply	N/A

## 2.4 Interface Cables

**Table 4: Interface Cables**

Port Identification	Connector Type	Cable Length	Shielded (Y/N)	Termination Point
13Vdc input/REM port	6 wire Circular	>1 m	N	Power source to EUT
Warning Module Out	4 wire circular	>1m	N	Warning Module

## 2.5 EUT Modifications

No modifications were performed in order to meet the test requirements.

## 2.6 Testing Algorithm

The EUT operates continuously when power is applied.

Worst case emission levels are provided in the test results data. PAD support unit was brought within range of the generator to activate receive warning alarms.

## 2.7 Test Location

Testing was performed on an Open Area Test Site (OATS) of Washington Laboratories, Ltd, 7560 Lindbergh Drive, Gaithersburg, MD 20879. Site description and site attenuation data have been placed on file with the FCC's Sampling and Measurements Branch at the FCC laboratory in Columbia, MD. The ISED OATS numbers are 3035A-1 and 3035A-2 for Washington Laboratories, Ltd. Site 1 and Site 2, respectively. Washington Laboratories, Ltd. has been accepted by the FCC and approved by ANAB under Testing Certificate AT-1448 as an independent FCC test laboratory.

## 2.8 Measurements

### 2.8.1 References

- ANSI C63.2 Specifications for Electromagnetic Noise and Field Strength Instrumentation
- ANSI C63.10:2013 Procedures for Compliance Testing of Unlicensed Wireless Devices

## 2.9 Measurement Uncertainty

All results reported herein relate only to the equipment tested. The basis for uncertainty calculation uses ANSI/NCSL Z540-2-1997 (R2002) with a type B evaluation of the standard uncertainty. Elements contributing to the standard uncertainty are combined using the method described in Equation 1 to arrive at the total standard uncertainty. The standard uncertainty is multiplied by the coverage factor to determine the expanded uncertainty which is generally accepted for use in commercial, industrial, and regulatory applications and when health and safety are concerned (see Equation 2). A coverage factor was selected to yield a 95% confidence in the uncertainty estimation.

**Equation 1: Standard Uncertainty**

$$u_c = \pm \sqrt{\frac{a^2}{div_a^2} + \frac{b^2}{div_b^2} + \frac{c^2}{div_c^2} + \dots}$$

Where  $u_c$  = standard uncertainty

a, b, c,.. = individual uncertainty elements

Div<sub>a, b, c</sub> = the individual uncertainty element divisor based on the probability distribution

Divisor = 1.732 for rectangular distribution

Divisor = 2 for normal distribution

Divisor = 1.414 for trapezoid distribution

**Equation 2: Expanded Uncertainty**

$$U = ku_c$$

Where U = expanded uncertainty

k = coverage factor

$k \leq 2$  for 95% coverage (ANSI/NCSL Z540-2)

Annex G)

$u_c$  = standard uncertainty

The measurement uncertainty complies with the maximum allowed uncertainty from CISPR 16-4-2. Measurement uncertainty is not used to adjust the measurements to determine compliance. The expanded uncertainty values for the various scopes in the WLL accreditation are provided in the table below.

**Table 5: Expanded Uncertainty List**

<b>Scope</b>	<b>Standard(s)</b>	<b>Expanded Uncertainty</b>
Conducted Emissions	CISPR11, CISPR22, CISPR14, FCC Part 15	$\pm 2.63$ dB
Radiated Emissions	CISPR11, CISPR22, CISPR14, FCC Part 15	$\pm 4.55$ dB

### 3 Test Equipment

Table 6 shows a list of the test equipment used for measurements along with the calibration information.

**Table 6: Test Equipment List**

Test Name: <b>Radiated Emissions</b>		Test Date: <b>9/26/2016</b>	
<b>Asset #</b>	<b>Manufacturer/Model</b>	<b>Description</b>	<b>Cal. Due</b>
856	EMCO - 6507	ACTIVE LOOP 1KHZ - 30MHZ	11/12/2017
823	AGILENT - N9010A	EXA SPECTRUM ANALYZER	10/31/2016
522	HP - 8449B	PRE-AMPLIFIER 1-26.5GHZ	10/10/2016
276	ELECTROMETRICS - BPA-1000	PRE-AMPLIFIER RF 50KHZ-1GHZ	10/30/2016
626	ARA - DRG-118/A	ANTENNA HORN	4/7/2018
382	SUNOL SCIENCES CORPORATION - JB1	ANTENNA BICONLOG	8/31/2017

## 4 Test Results

### 4.1 Occupied Bandwidth: (FCC Part §2.1049, RSS –Gen sect 6.6)

Occupied bandwidth was performed by setting the EUT near the loop antenna to allow for sufficient pickup of the signal.

The transmit signal is a 73 kHz non-modulated CW signal; therefore there is no measurable bandwidth.

### 4.2 Radiated Spurious Emissions: (FCC Part §15.209, RSS-Gen Table 6)

Transmitters operating under §15.209 & ISED RSS 210 (RSS-GEN) must comply with the radiated emissions listed in the following table:

Measurements were conducted in accordance with ANSI C63.10 section 6.4 “Radiated emissions from unlicensed wireless devices below 30 MHz”

**Table 7: Radiated Emissions Limits**

Frequency (MHz)	Field Strength (microvolts/meter)	Measurement Distance (meters)
0.009 - 0.490	2400/F(kHz)	300
0.490 - 1.705	24000/F(kHz)	30
1.705 - 30.0	30	30
30 - 88	100	3
88 - 216	150	3
216 - 960	200	3
Above 960	500	3

#### 4.2.1 Test Procedure

The EUT was placed on motorized turntable for radiated testing on a 30-meter open field test site. The emissions from the EUT were measured continuously at every azimuth by rotating the turntable

For frequencies between 10 kHz and 30 MHz, a loop antenna was mounted on a tripod at height of 1 m. The Loop antenna was rotated about its vertical and horizontal axis to determine the highest emissions.

For frequencies above 30MHz the receiving antennas were mounted on an antenna mast to determine the height of maximum emissions. The height of the antenna was varied

between 1 and 4 meters. Both the horizontal and vertical field components were measured.

Frequencies below 490kHz with limits at 300 meters were tested at 30 meters with the measurement results corrected to 300 meters per ANSI C63.10 section 6.4 and section 6.4.4.4 “Calculation of extrapolation factor from two points” using the below calculations:

$$\text{Correction} = 20 * \{ ((\text{Log}(E1/E2)) / (\text{Log}(d1/d2))) \}$$

For this device: at 73 kHz fundamental

E1=6671.1709uV/m at 30m (d1), E= 2231269.7uV/m at 3m (d2) thus;

$$\begin{aligned} \text{Correction} &= 20 * \{ ((\text{Log}(6671.1709/2231269.7)) / (\text{Log}(30/3))) \} \\ &= 20 * \{ ((\text{Log}(0.0029899)) / (\text{Log}(10))) \} \\ &= 20 * (-2.52435) = -50.48\text{dB correction.} \end{aligned}$$

**Table 8: Extrapolation Table**

	Frequency (MHz)	Antenna Orientation	Azimuth (Degree)	Ant. Ht (m)	SA Level (dBuV)	Corr Factor (dB)	Corr. Level (uV/m)	Note
3m test	0.073	X	165.00	1.00	107.69	19.3	2231269.7	Peak
30m test	0.073	X	90.00	1.00	57.20	19.3	6671.2	Peak

Note: This extrapolation was verified at 73 kHz, 146 kHz, and 219 kHz.



Measurements of frequencies above 30MHz were made at a distance of 3m in accordance with ANSI C63.10 section 6.5 “Radiated emissions from unlicensed wireless devices in the frequency range of 30 MHz to 1000 MHz” and section 6.6 “Radiated emissions from unlicensed wireless devices above 1 GHz”. Above 1 GHz RF absorber was placed between the EUT and Receive antenna. In addition above 1GHz the EUT was raised to 1.5m above the floor.

The EUT was scanned from 10k to 5GHz (in order to include the receiver data).

The EUT was examined in three orthogonal and the orthogonal that demonstrated the highest emissions was reported.

All Fundamental and Harmonics were tested for peak emissions and compared to the Average limits as this is a CW signal. As the CW complies with the average limits it also complies with the peak limits of part 15.35. All other spurious signals were tested using average or quasi-peak detectors as specified.

In accordance with FCC part 15.209 (d) emissions in the bands 9-90 kHz and 110-490 kHz are performed using an average detector. All other readings below 1000MHz were taken with a quasi-peak detector.

Resolution bandwidths used for frequencies measured between:

- 9 kHz – 150kHz,      RBW = 200Hz
- 150kHz – 30MHz,      RBW = 9kHz
- 30MHz – 1GHz,      RBW = 120kHz

and, for frequencies measured above 1GHz:

- RBW = 1MHz

In addition as the user may occasionally adjust the power the lowest and highest power readings were taken at the fundamental. Spurious readings were taken at the highest power level

**Table 9: Fundamental Levels**

Frequency (MHz)	Polarity H/V	Azimuth (Degree)	Ant. Htt (m)	SA Level (dBuV)	Corr Factors (dB)	Corr. Level (uV/m)	Extrapolation Factor for 300 to 30m testing below 490kHz (dB)	Adjusted Level (uV/m)	Limit (uV/m)	Margin (dB)
Hi Power										
0.073	X	90.00	1.00	57.20	19.3	6671.2	-50.48	20.0	32.9	-4.3
0.073	Y	45.00	1.00	52.62	19.3	3939.1	-50.48	11.8	32.9	-8.9
0.073	Z	100.00	1.00	47.05	19.3	2073.5	-50.48	6.2	32.9	-14.5
Low Power										
0.073	X	190.00	1.00	36.38	19.3	607.2	-50.48	1.8	32.9	-25.2
0.073	Y	90.00	1.00	34.20	19.3	472.3	-50.48	1.4	32.9	-27.3
0.073	Z	90.00	1.00	32.10	19.3	370.9	-50.48	1.1	32.9	-29.4

**Table 10: Radiated Emissions Test Data < 30MHz**

Frequency (MHz)	Polarity H/V	Azimuth (Degree)	Ant. Height (m)	SA Level (dBuV)	Corr Factors (dB)	Corr. Level (uV/m)	Extrapolation Factor for 300 to 30m testing below 490kHz (dB)	Adjusted Level (uV/m)	Limit (uV/m)	Margin (dB)
0.146	X	270.00	1.00	33.47	19.1	425.2	-50.5	1.3	16.44	-22.2
0.146	Y	270.00	1.00	32.90	19.1	398.2	-50.5	1.2	16.44	-22.8
0.146	Z	315.00	1.00	32.50	19.1	380.3	-50.5	1.1	16.44	-23.2
0.219	X	45.00	1.00	41.50	19.1	1077.5	-50.5	3.2	10.96	-10.6
0.219	Y	45.00	1.00	43.20	19.1	1310.4	-50.5	3.9	10.96	-8.9
0.219	Z	135.00	1.00	41.80	19.1	1115.3	-50.5	3.3	10.96	-10.3
0.292	X	45.00	1.00	32.80	19.2	397.2	-50.5	1.2	8.22	-16.8
0.292	Y	45.00	1.00	30.90	19.2	319.2	-50.5	1.0	8.22	-18.7
0.292	Z	0.00	1.00	28.90	19.2	253.5	-50.5	0.8	8.22	-20.7
0.365	X	90.00	1.00	26.80	19.2	199.7	-50.5	0.6	3.63	-15.7
0.365	Y	90.00	1.00	24.23	19.2	148.4	-50.5	0.4	3.63	-18.2
0.365	Z	135.00	1.00	24.20	19.2	148.0	-50.5	0.4	3.63	-18.3

No other harmonic or spurious emissions were detectable below 30MHz

Note: Since the peak readings are below the applicable 15.209 average limits the peak measurements do not exceed the part 15.35 limit (average limit plus 20dB). Therefore the unit was not tested using an average detector in these ranges and is assumed to comply with the peak and average requirements.

**Table 11: Radiated Emissions Test Data > 30MHz (TX and RCV)**

Frequency (MHz)	Polarity H/V	Azimuth (Degree)	Ant. Height (m)	SA Level (dBuV)	Corr Factors (dB)	Corr. Level (uV/m)	Limit (uV/m)	Margin (dB)
33.48	V	190.00	1.00	39.30	-7.9	37.3	100.0	-8.6
40.35	V	290.00	1.00	43.96	-12.9	35.9	100.0	-8.9
49.78	V	180.00	1.00	42.83	-18.5	16.5	100.0	-15.7
52.57	V	45.00	1.00	47.25	-19.1	25.5	100.0	-11.9
57.20	V	45.00	1.10	48.57	-19.2	29.4	100.0	-10.6
71.31	V	90.00	1.10	46.90	-17.9	28.3	100.0	-11.0
76.26	V	190.00	1.10	43.79	-17.9	19.8	100.0	-14.1
84.43	V	90.00	1.20	55.10	-18.3	69.2	100.0	-3.2
109.10	V	90.00	1.20	39.34	-13.3	20.0	150.0	-17.5
184.92	V	180.00	1.60	40.73	-13.9	22.0	150.0	-16.7
207.07	V	190.00	1.12	42.23	-13.8	26.3	150.0	-15.1
216.67	V	190.00	1.70	40.60	-14.2	20.8	200.0	-19.7
254.62	V	45.00	2.30	42.50	-13.1	29.4	200.0	-16.7
509.70	V	90.00	2.70	39.80	-5.1	54.4	200.0	-11.3
33.79	H	270.00	4.00	38.99	-8.1	35.2	100.0	-9.1
54.27	H	180.00	3.80	46.69	-19.3	23.4	100.0	-12.6
68.20	H	180.00	3.50	45.80	-18.0	24.4	100.0	-12.2
72.16	H	45.00	4.00	50.91	-17.8	45.2	100.0	-6.9
86.34	H	180.00	3.80	54.98	-18.2	69.2	100.0	-3.2
108.44	H	170.00	3.60	40.40	-13.4	22.3	150.0	-16.5
123.16	H	180.00	3.50	42.10	-11.7	32.9	150.0	-13.2
161.50	H	170.00	2.80	48.50	-13.3	57.5	150.0	-8.3
208.36	H	180.00	2.60	42.90	-14.1	27.5	150.0	-14.7
218.29	H	45.00	2.50	41.10	-14.2	22.2	200.0	-19.1
257.04	H	290.00	2.00	49.85	-12.9	70.6	200.0	-9.1

No signals were noted above those listed.

### 4.3 Receiver Radiated Emissions (RSS-210 sect 2.5, RSS-GEN sect 6.1)

#### 4.3.1 Requirements

Test Arrangement: Table Top

Compliance Standard: RSS-Gen sect 7.1.2

RSS-Gen Compliance Limits for Receivers	
Frequency	Limits
30-88 MHz	100 $\mu$ V/m
88-216 MHz	150 $\mu$ V/m
216-960 MHz	200 $\mu$ V/m
>960MHz	500 $\mu$ V/m

#### 4.3.2 Test Procedure

The requirements of RSS-GEN call for the EUT to be placed on an 80 cm high 1 X 1.5 meters non-conductive motorized turntable for radiated testing on a 3-meter open field test site. The emissions from the EUT were measured continuously at every azimuth by rotating the turntable. Bi-conical and log periodic broadband antennas were mounted on an antenna mast to determine the height of maximum emissions. The height of the antenna was varied between 1 and 4 meters. The output of the antenna was connected to the input of the spectrum analyzer and the emissions in the frequency range of 30 MHz to 5 GHz were measured. Cables were varied in position to produce maximum emissions. Both the horizontal and vertical field components were measured.

The output from the antenna was connected, via a preamplifier, to the input of the spectrum analyzer. The detector function was set to quasi-peak, peak, or average as appropriate. The measurement bandwidth of the spectrum analyzer system was set to at least 120 kHz, with all post-detector filtering no less than 10 times the measurement bandwidth.

Measurements of frequencies above 30MHz were made at a distance of 3m in accordance with ANSI C63.10 section 6.5 "Radiated emissions from unlicensed wireless devices in the frequency range of 30 MHz to 1000 MHz" and section 6.6 "Radiated emissions from unlicensed wireless devices above 1 GHz". Above 1 GHz RF absorber was placed between the EUT and Receive antenna. In addition above 1GHz the EUT was raised to 1.5m above the floor.

All measurements above 1GHz were made at a distance of 3m with a Resolution Bandwidth of 1MHz with an RMS average detector.

#### 4.3.3 Test Data

The EUT complies with the requirements of RSS 210 (RSS-GEN limits) as shown in Table

#### 4.3.3.1 Radiated Data Reduction and Reporting

To convert the raw spectrum analyzer radiated data into a form that can be compared with the FCC limits, it is necessary to account for various calibration factors that are supplied with the antennas and other measurement accessories. These factors are included into the antenna factor (AF) column of the table and in the cable factor (CF) column of the table. The AF (in dB/m) and the CF (in dB) is algebraically added to the raw Spectrum Analyzer Voltage in dB $\mu$ V to obtain the Radiated Electric Field in dB $\mu$ V/m. This logarithm amplitude is converted to linear amplitude, and then compared to the ISED limit.

Example:

Spectrum Analyzer Voltage:           VdB $\mu$ V

Antenna Correction Factor:           AFdB/m

Cable Correction Factor:           CFdB

Electric Field:                       EdBV/m =    V dB $\mu$ V + AFdB/m + CFdB

To convert to linear units of measure: EdBV/m/20 Inv log

**Table 12: Receiver Radiated Emissions Test Data > 30MHz (TX and RCV)**

Frequency (MHz)	Polarity H/V	Azimuth (Degree)	Ant. Height (m)	SA Level (dBuV)	Corr Factors (dB)	Corr. Level (uV/m)	Limit (uV/m)	Margin (dB)
33.48	V	190.00	1.00	39.30	-7.9	37.3	100.0	-8.6
40.35	V	290.00	1.00	43.96	-12.9	35.9	100.0	-8.9
49.78	V	180.00	1.00	42.83	-18.5	16.5	100.0	-15.7
52.57	V	45.00	1.00	47.25	-19.1	25.5	100.0	-11.9
57.20	V	45.00	1.10	48.57	-19.2	29.4	100.0	-10.6
71.31	V	90.00	1.10	46.90	-17.9	28.3	100.0	-11.0
76.26	V	190.00	1.10	43.79	-17.9	19.8	100.0	-14.1
84.43	V	90.00	1.20	55.10	-18.3	69.2	100.0	-3.2
109.10	V	90.00	1.20	39.34	-13.3	20.0	150.0	-17.5
184.92	V	180.00	1.60	40.73	-13.9	22.0	150.0	-16.7
207.07	V	190.00	1.12	42.23	-13.8	26.3	150.0	-15.1
216.67	V	190.00	1.70	40.60	-14.2	20.8	200.0	-19.7
254.62	V	45.00	2.30	42.50	-13.1	29.4	200.0	-16.7
509.70	V	90.00	2.70	39.80	-5.1	54.4	200.0	-11.3
33.79	H	270.00	4.00	38.99	-8.1	35.2	100.0	-9.1
54.27	H	180.00	3.80	46.69	-19.3	23.4	100.0	-12.6
68.20	H	180.00	3.50	45.80	-18.0	24.4	100.0	-12.2
72.16	H	45.00	4.00	50.91	-17.8	45.2	100.0	-6.9
86.34	H	180.00	3.80	54.98	-18.2	69.2	100.0	-3.2
108.44	H	170.00	3.60	40.40	-13.4	22.3	150.0	-16.5
123.16	H	180.00	3.50	42.10	-11.7	32.9	150.0	-13.2
161.50	H	170.00	2.80	48.50	-13.3	57.5	150.0	-8.3
208.36	H	180.00	2.60	42.90	-14.1	27.5	150.0	-14.7
218.29	H	45.00	2.50	41.10	-14.2	22.2	200.0	-19.1
257.04	H	290.00	2.00	49.85	-12.9	70.6	200.0	-9.1