



110 Nortech Parkway
San Jose, California, 95134

**FCC Part 15, Subpart E,
UNII (Part 15.401)
Certification Application**

**EMI Test Report
and
Technical Documentation
on
Airespace Virtual Access point.
Model: 1200**

FCC ID: QTZWNAP1200AB

Prepared by:
David Waitt
202 Calvert Drive #217
Cupertino, Ca. 95014
david@waitt.us
(408) 832 7053

Table of Contents

<u>Section</u>	<u>Page</u>
General information-----	3
Detailed product information-----	4
Results summary-----	5
Test facilities-----	6
Test Equipment-----	7
Test methods-----	8
Test Results	
Maximum power at RF Output-----	11
26dB Bandwidth-----	12
Power spectral density-----	16
Out of band emissions -----	20
Peak Excursion -----	40
Radiated emissions in restricted bands-----	44
AC Line Conducted Emissions-----	51

General Information

Unit(s) Under Test: Airespace Virtual Access point
Model: 1200
Product Description: IEEE 802.11A Access point

FCC ID: **QTZWNAP1200AB**

Tested For: Airespace
110 Nortech Parkway
San Jose, CA. 95134

Tested At: Elliott Laboratories
684 West Maude Ave
Sunnyvale, CA 94086

Tested By: Juan Martinez, Sr. Test Engineer, Elliott Laboratories
David Waitt, (Independent Consultant)

Test Specifications: FCC CFR 47, Part Subpart E, (15 401 UNII)

Test Date: March 2003

Requested Certification: Part 15 Subpart E Certification

Detailed Product Information / Operational Description

The Airespace radio is an IEEE 802.11 A/B Virtual Access point (VAP) intended to be professionally installed and configured in corporate and industrial environments.

NOTE: Though the 1200 A/B access point is an 802.11 A/B access point, this report addresses only the 802.11 A (UNII) aspects of the access point. Data supporting the 802.11 B portion of the access point can be found in the Part 15.247 report.

The access point utilizes integral antennas on the 802.11 A bands. The access point includes two integral 5 GHz patch antennas pointing 180° from each other to create a somewhat omni directional 5GHz pattern. The VAP includes only a single 2.4GHz patch antenna (the 2.4 GHz antenna is discussed in the 15.247 report). The effective gain of the 5 GHz antenna path (the antenna switch and the antenna itself) is 5.9dBi. The diagrams below outline the RF path from the output of the mini PCI module within the access point to the integral antennas within the access point. See the antenna patterns included with this application (Note that only the Subpart E, 15.401 UNII 5 GHz portion is covered by this particular report)

There is a provision for attaching external 5 GHz antennas to the access point (which, when implemented will disable the integral antenna by means of the switch) however at this time, since external 5GHz antennas are not included in this certification application, the ability to utilize an external antenna on this band, and even switch the antenna selection switch to the other position will be disabled in the configuration software. The hardware was put in place to support the future use of external 5 GHz antennas once such use is authorized by the commission either by permissive change of new grant.

The access point is powered either by a external 48V power supply or via power over Ethernet.

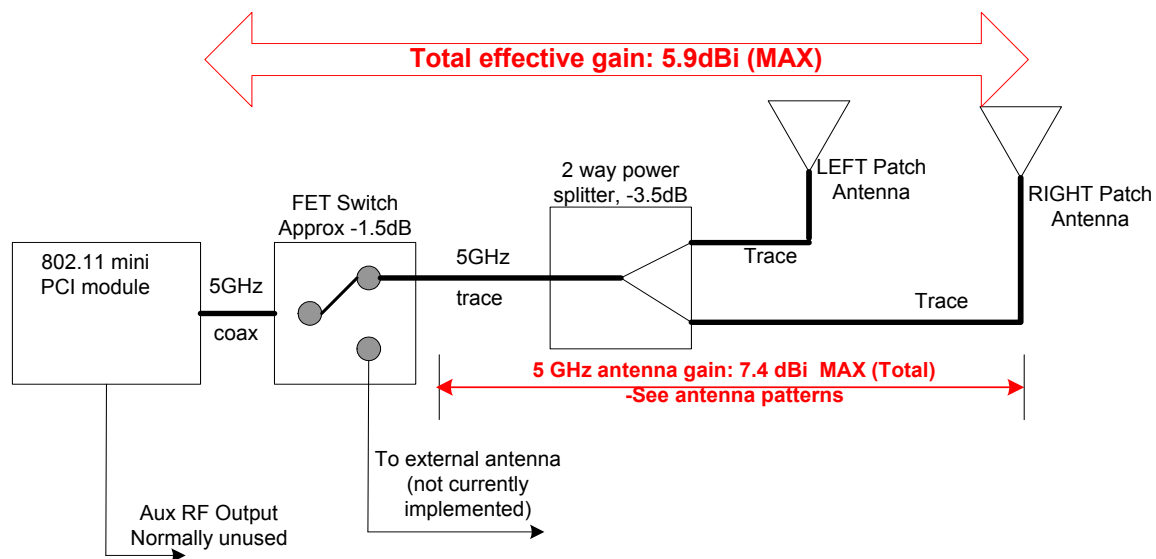

RF Path Schematics

Report Organization and Results Summary

This report presents the results of the tests that verify compliance with FCC Part 15.401. Though this product must comply with FCC Part 15.247 as well, only the 15.401 (UNII) results are contained in this report. The compliance information for Part 15.247 is contained in a separate report.

A brief results summary of all the in this report is below.

Part 15 Paragraph	Test	Results
15.407(a) (5)	Power Spectral Density	-4.0 dBm MAX
15.407(b) (1)	Out of Band Emissions (5.15 - 5.25)	-44.5 dBm MAX
15.407(b) (1)	Out of Band Emissions (5.25 - 5.35)	-39.33 dBm MAX
15.407(b) (1)	Out of Band Emissions (5.725 - 5.825)	-34.83 dBm MAX
15.407(a)	26dB Bandwidth	45.58 MHz
15.407(a) (1)	Transmit Power (5.15 - 5.35)	17 dBm MAX
15.407(a) (3)	Transmit Power (5.275 - 5.825)	19.7 dBm MAX
15.407(a) (6)	Peak Excursion	2.97 MAX
15.205	Radiated Emissions in Restricted bands	2.83 dB in spec
CISPR 22	AC Line Conducted Emissions	15.25 dB in Spec

Test Facilities

All of the certification tests were performed at:

Elliott Labs
684 West Maude Ave
Sunnyvale, CA 94086

General:

Final radiated test measurements were taken in March 2003 at the Elliott Laboratories Open Area Test Site #4.

The test site contains separate areas for radiated and conducted emissions testing. Pursuant to section 2.948 of the Rules, construction, calibration, and equipment data has been filed with the Commission.

The FCC recommends that ambient noise at the test site be at least 6 dB below the allowable limits. Ambient levels are below this requirement with the exception of predictable local TV, radio, and mobile communications traffic. The test site contains separate areas for radiated and conducted emissions testing. Considerable engineering effort has been expended to ensure that the facilities conform to all pertinent FCC requirements.

OATS:

The FCC has determined that radiation measurements made in a shielded enclosure are not suitable for determining levels of radiated emissions. Radiated emissions are performed in an open field environment. The test site is maintained free of conductive objects within the CISPR defined elliptical area incorporated in ANSI C63.4 Guidelines.

Antenna, Antenna Mast and Turntable

The Horn antennas that are used to measure radiated emissions above 1000MHz are mounted on a non-conductive antenna mast equipped with a motor drive to vary the antenna height.

ANSI C63.4 specifies that the test height above the ground plane shall be 80cm unless the equipment is intended to be floor mounted. During the radiated emissions tests the equipment is positioned on a motorized turntable in conformance with the ANSI requirement.

Equipment Lists

Instrument Calibration

All test equipment is regularly checked to ensure that performance is maintained in accordance with the manufacturer's specifications. All antennas are calibrated at regular intervals with respect to tuned half-wave dipoles. An exhibit of this report contains the list of test equipment used and calibration information.

The following test equipment was used to perform the testing

Elliott Test Equipment

<u>Item</u>	<u>Desc.</u>	<u>Manufacturer</u>	<u>Model</u>	<u>S/N</u>	<u>(Elliott #)</u>	<u>Cal due date</u>
Spectrum Analyzer		Hewlett Packard	8595EM			2 Feb 2004
3.5 GHz HPF		HP	NA	84300-80038		1 Mar 04
Pre Amp		Miteq	ASF 44	805817		7 Jan 04
Antenna		EMCO	3115	9711-5359		20 April 04
Peak Power Meter		Rhode & Schwartz	NRYS	835360/070		6 Sept 03
Power Head		Rhode & Swartz		836019/016		6 Sep 03
Microwave test system		Hewlett Packard	84125			2 April 2003

Additional Test Equipment

<u>Item</u>	<u>Desc.</u>	<u>Manufacturer</u>	<u>Model</u>	<u>S/N</u>	<u>Cal due date</u>
Peak Power meter		Agilent	4416A	GB40320299	7 July 03
Power Head		Agilent	E9327A	US40440899	16 Oct 03
Spectrum Analyzer		Agilent	E4404B	US40521093	3 Sep 03

Test Methods

Many of the tests are performed at a low, middle and high channel of the applicable band. The typical frequencies used for the test for each band are listed below. Recall that this report details the results for the UNII bands only. Where applicable, the test procedures outlined in FCC Public notice DA 02-2138 (30 Aug 2002) were used.

UNII 802.11 A	
5.15 – 5.25 GHz & 5.25 – 5.35 GHz	
Channel	Freq(MHz)
Low	5180
Mid	5260
High	5320

UNII / 802.11 A	
5.725 5.825 GHz	
Channel	Freq(MHz)
Low	5745
Mid	5765
High	5805

In order to comply with the “radiated emissions in restricted bands” requirements the transmit power had to be lowered on some of the channels at the edges of the band. The maximum power setting that yielded compliance with the radiated emissions requirements will be programmed into the configuration firmware of the access point ensuring that maximum possible power setting will be correct for each channel. Given that the access point will normally be operated at these power settings, they were also used during the “bench top” conducted RF tests (spectral density, bandwidth etc).

The tests listed below are performed using the basic test setup shown below. In several cases, the EUT was running special diagnostic firmware to allow it to transmit random data on a particular channel indefinitely.

Part 15	Test
15.407(a)(5)	Power Spectral Density
15.407(b)(1)	Out of Band Emissions (5.15 - 5.25)
15.407(b)(1)	Out of Band Emissions (5.25 - 5.35)
15.407(b)(1)	Out of Band Emissions (5.725 - 5.825)
15.407(a)	26dB Bandwidth
15.407(a)(1)	Transmit Power (5.15 - 5.25)
15.407(a)(2)	Transmit Power (5.25 - 5.35)
15.407(a)(3)	Transmit Power (5.275 - 5.825)
15.407(a)(6)	Peak Excursion

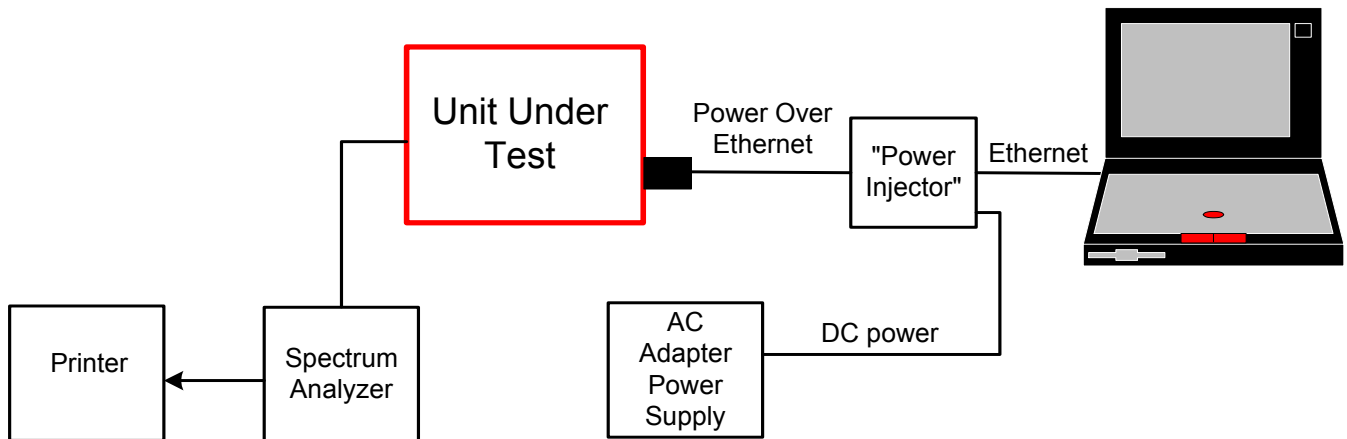

Basic Conducted RF Bench Test Setup

Unless otherwise noted, the support equipment for the bench tests is listed below.

Support Equipment				
Description	Model number	FCC ID or SN	Manufacturer	Power Cable
Laptop	Armada E 500	P31000T4X20DC12N2	Compaq	Laptop PS
Test Software	Atheros Radio Test		Atheros	
48VDC AC adapter	Generic		Generic	Standard Twin lead DC wire

Test Results

Detailed test procedures and test results are contained in the following sections. In cases where the test setup differs from the Conducted RF test setup shown earlier, the test setup is also presented.

Test Conditions			
Temperature	20 C	Humidity:	40%
ATM pressure	1017 mBar	Grounding:	None
Tested By	David Waitt	Date of Test:	March 2003
Test Reference	Refer to individual test results		
Tested Range	Test Dependent		
Test Voltage	48 VDC to the VAP		
Modifications	No modifications were made to the unit during the tests		

802.11 A Maximum RF Power Output at Antenna Terminals

Specifications:

FCC Specification: Paragraph(s): 15.401(a)(1), 15.401(a)(2), 15.401(a)(3)

Procedure:

The test was conducted by connecting the secondary output of the 802.11 module directly to a peak power meter. This measured power is therefore the same level that will be present at the input of the FET antenna switch under normal operation.

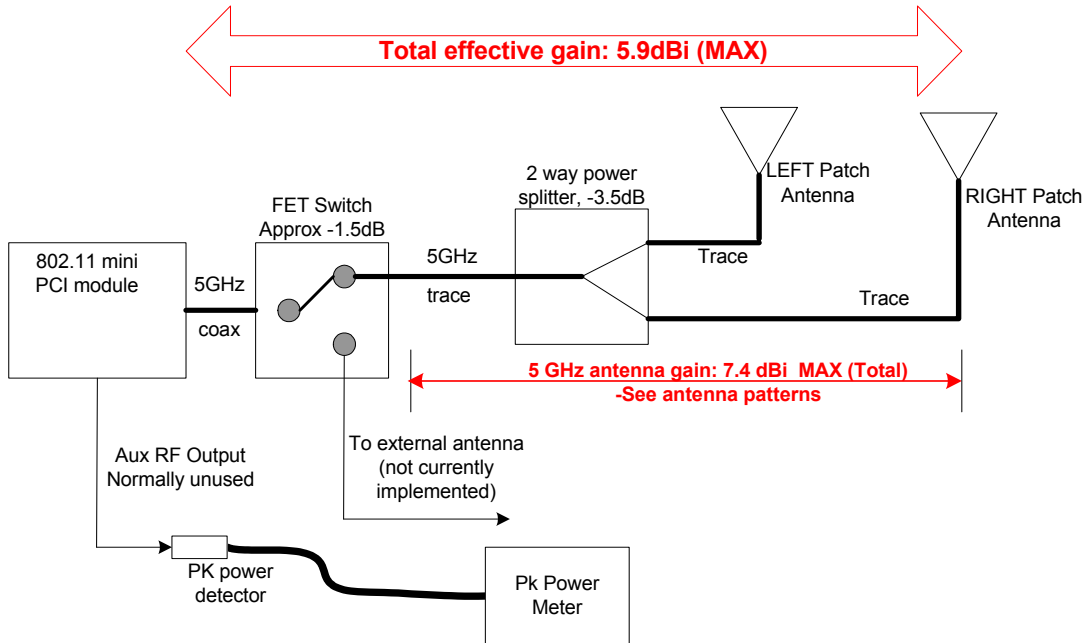

The unit was tuned to the test channels and configured to transmit random data packets. The transmit power was measured directly off of the meter.

Because the unit will be operated at different power levels depending on the channel / band being used, the RF power out was measured at the appropriate power setting for the given test channel / band. The settings that were used during the test are the settings that will be entered into the firmware of the VAP. These firmware configuration limits will ensure that the power levels are not exceeded.

RF Transmit Power Result:

The following power levels were measured on low, mid and high channels for each sub-band. Measured using a Rhode & Schwartz Power Meter with a peak power sensor in average mode

Pout settings Vs. Channel	Frequency (MHz)	Specification (dBm) into 6 dBi	Measured Pout (dBm)	Measured Pout (Watts)
5 GHz UNII upper	5745.00	30	19.7	.093
	5765.00	30	19.7	.093
	5785.00	30	19.4	.087
	5805.00	30	18.1	.065
5 GHz UNII lower	5180.00	17	14.5	.028
	5220.00	17	17.0	.050
	5240.00	17	16.9	.049
	5260.00	24	16.9	.049
	5290.00	24	16.7	.047
	5320.00	24	14.0	.025

Channel 153 (5765)

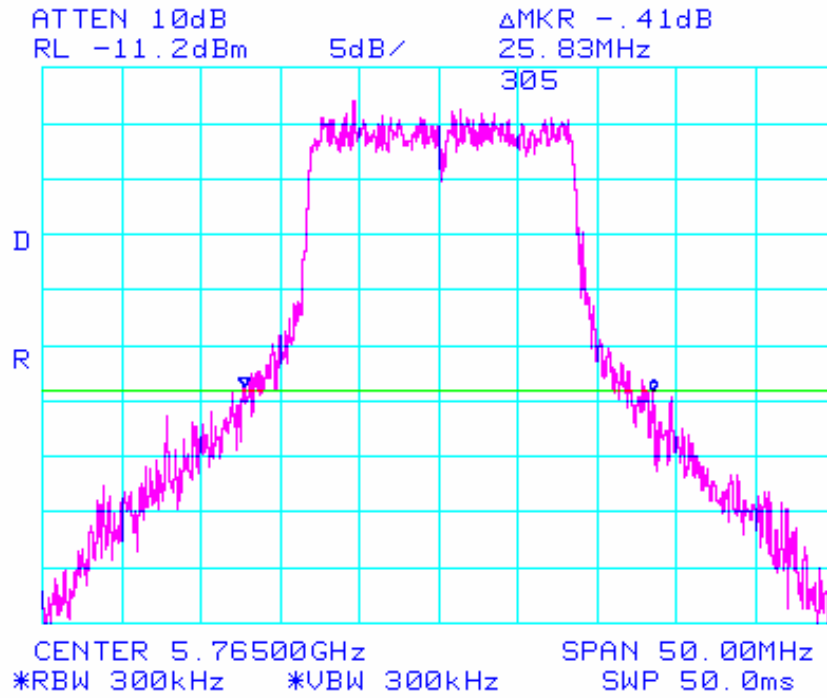

Channel 149 (5745)

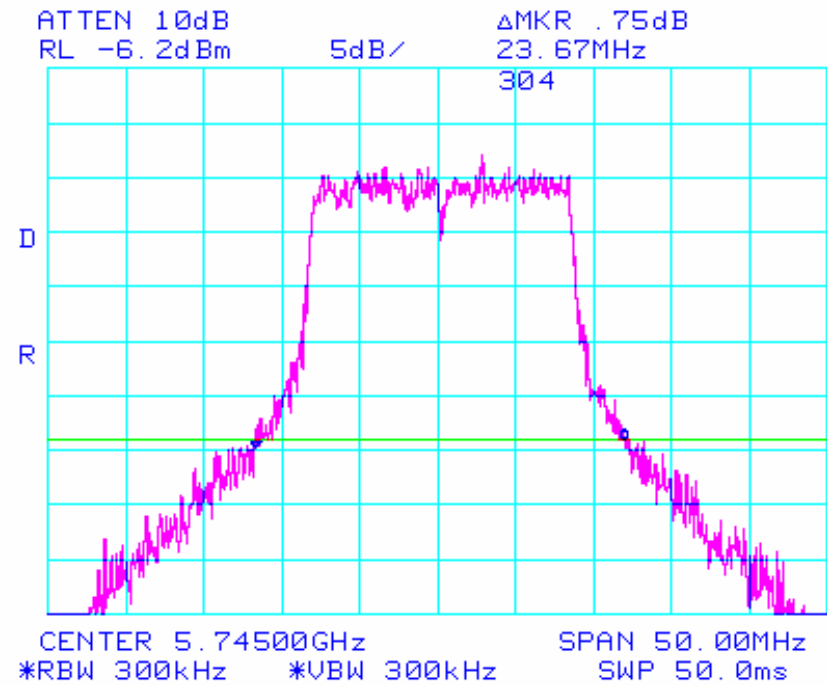

Channel 64 (5320)

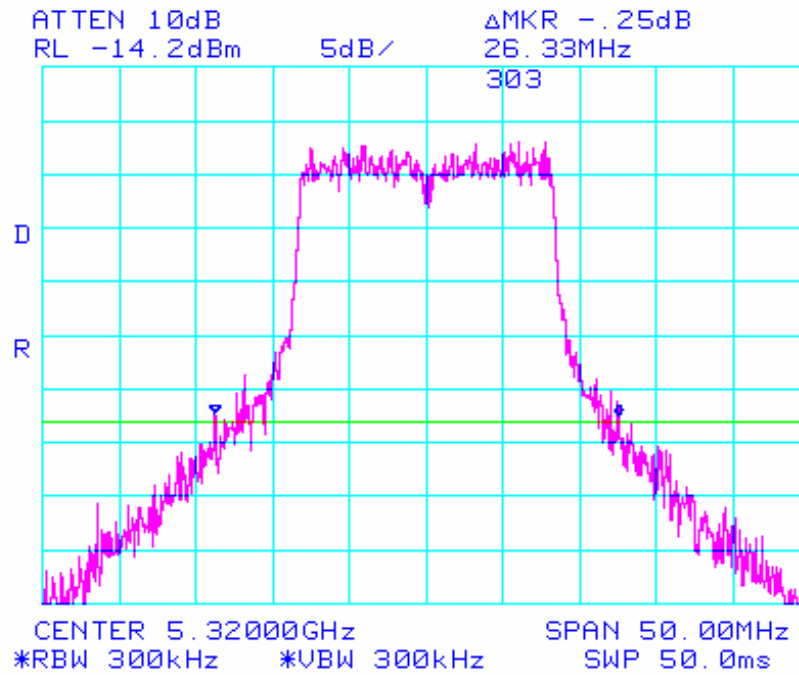

Channel 52 (5260)

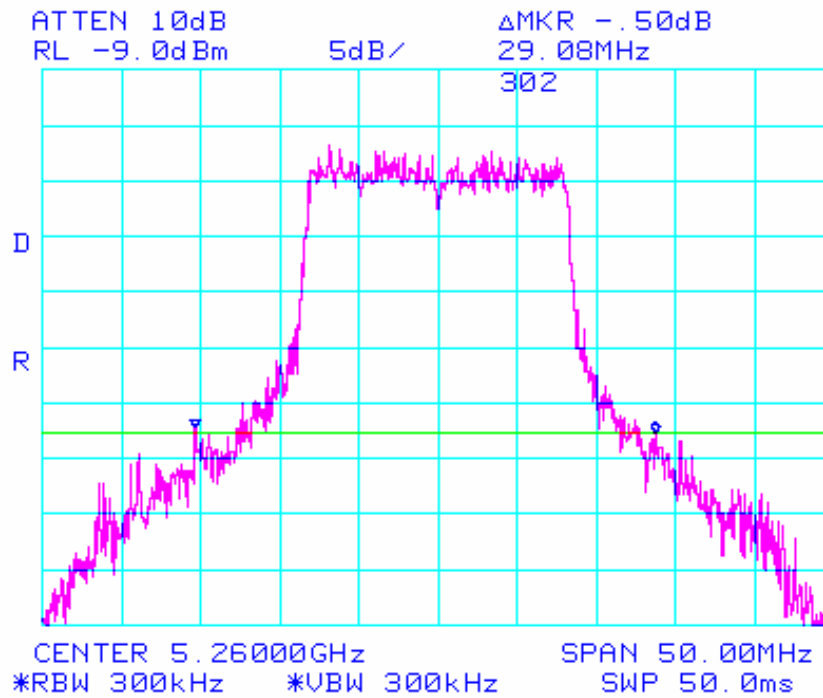

Channel 36 (5180)

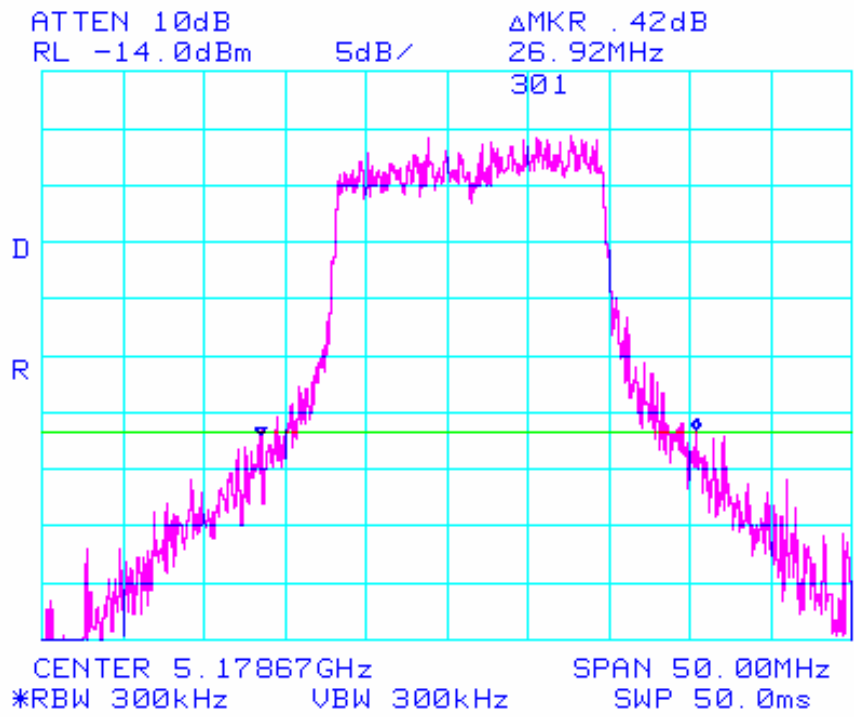

5 GHz Power Spectral Density

Specification

FCC Specification: Paragraph 15.407(a)(5)

Procedure:

The test setup was configured as shown in the conducted test setup. The UUT was configured to continuously transmit random data packets. Initially the bandwidth of the entire channel was examined. Using MAX HOLD and peak search, the frequency with the maximum power was determined.

The above measurements were made using RBW = 1MHz, VBW = 1MHz, video averaging on. The peak PSD of 11.7 dBm did not exceed the maximum permitted average PSD of 10dBm (5.15 to 5.25 GHz band) or 11dBm (5.25-5.35GHz band), (Peak PSD limits have an additional 6 dB) so no restriction are placed on the output power or average PSD with respect to RSS 210.

The power spectral density was measured at the designated test channels with the appropriate power setting for the given test channel.

Results:

Frequency (MHz)	FCC P.S.D. (dBm/MHz)	FCC Limit (dBm)
5805	-8.3	17.0
5765	-4.4	17.0
5745	-4.5	17.0
5320	-6.8	11.0
5260	-4.0	11.0
5180	-6.4	4.0

Channel 149 (5745)

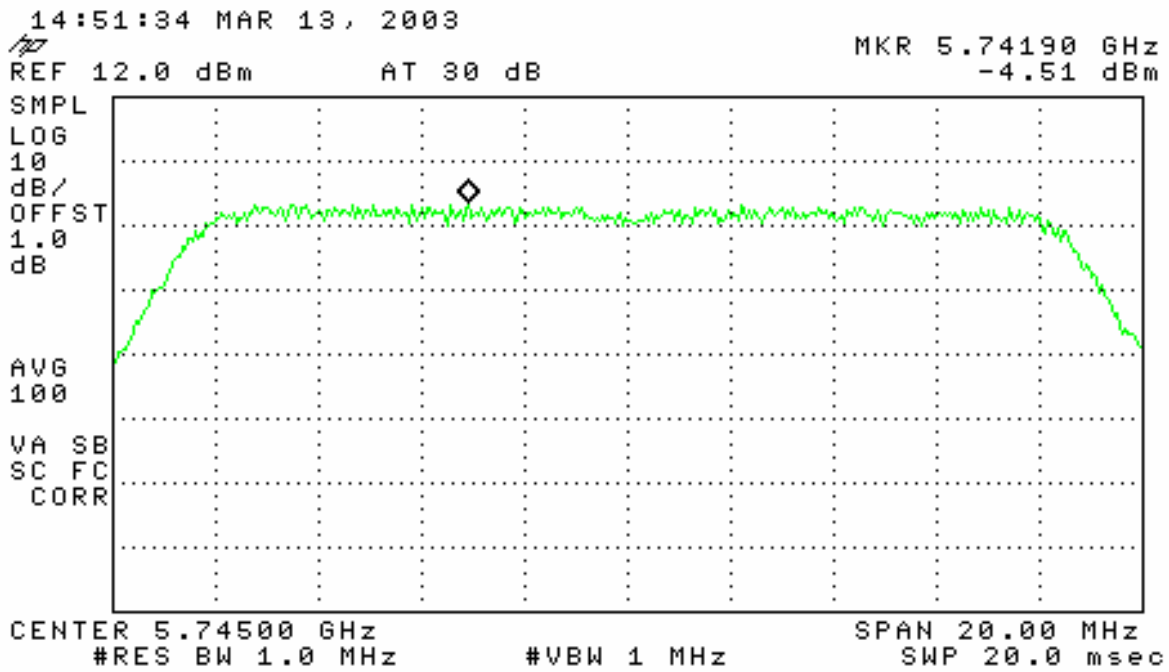

Channel 64 (5320)

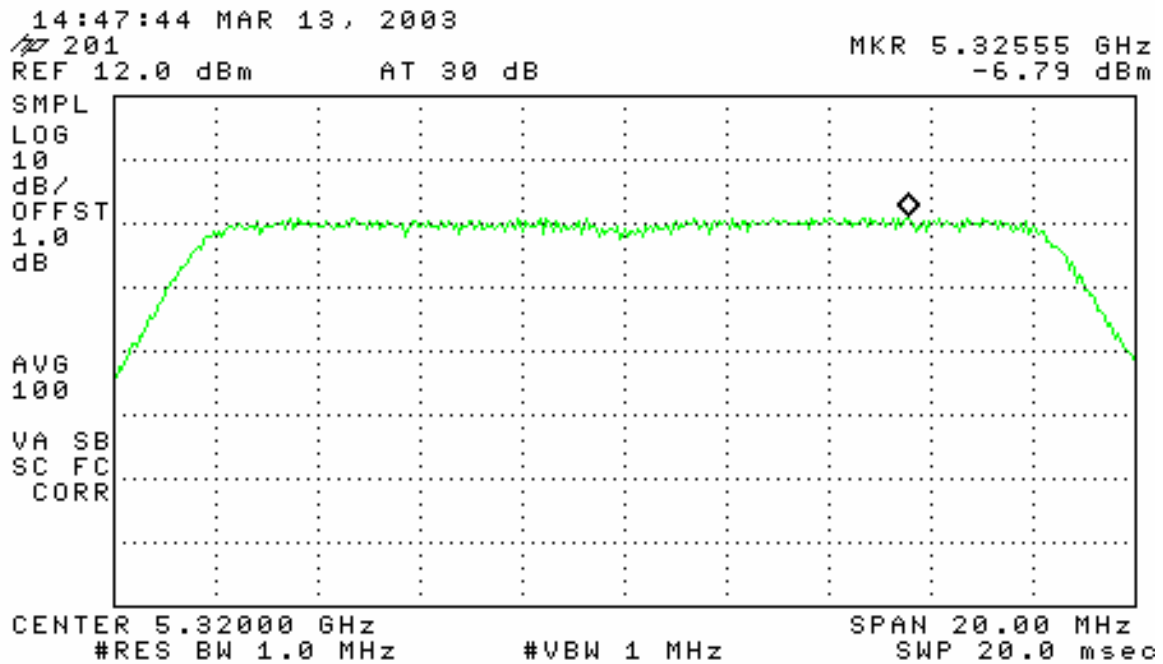

Channel 52 (5260)

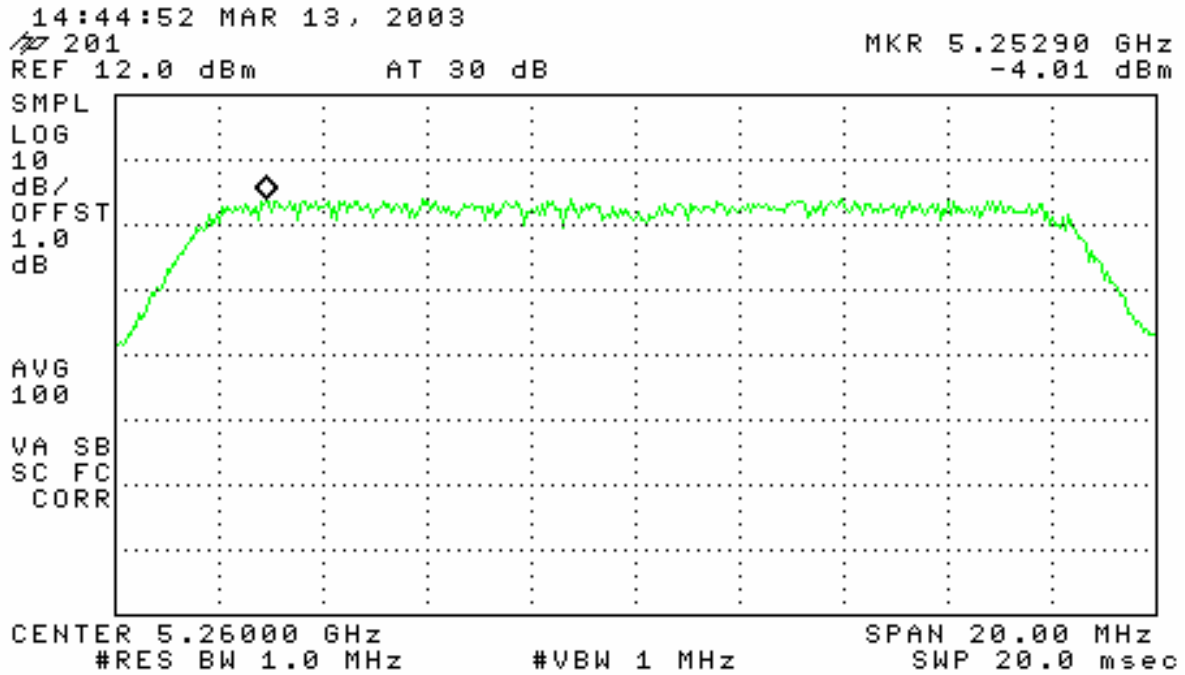

Channel 36 (5180)

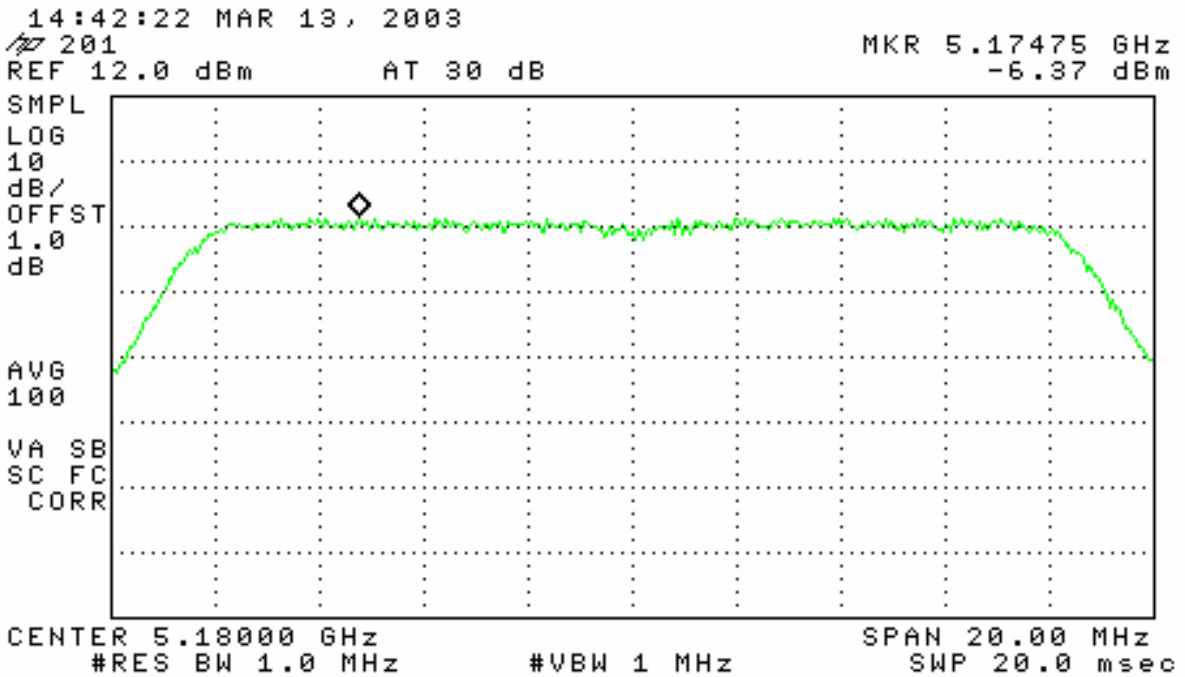

5 GHz Out of band Spurious Emissions

Specification

FCC Specifications: Paragraphs 15.407(b)(1), 15.407(b)(2), 15.407(b)(3),

Procedure:

The test was configured as shown in the Conducted RF test setup. The UUT was configured to transmit random data packets. The band from 1 GHz to 40GHz was examined spurious emissions. This test was conducted on the low middle and high channels with the UUT configured to the appropriate power setting indicated in the "power setting table" depending on the test channel.

Limit Calculation:

Antenna Gain: 5.9dBi

Out of band signal limit: -27dBm/MHz EIRP (for signals not in a restricted band)

Conducted limit: 27dBm/MHz - 5.9 dBi = 32.9dBm/MHz

(This assumes that the antenna gain is 5.9dBi within 100MHz of the upper and lower band edges.). For signals greater than 100 MHz from the band edge, A radiated measurement was made if the amplitude fo the signal exceeded -37 dBm

Results:

Tabular results are on the following page followed by plots of the radiated emissions.

Results:**Lower UNII band(s) emissions summary**

Xmit Freq (MHz)	Frequency Range	Spurious Freq (GHz)	Highest Spurious Signal (dBm)	Limit (-27dBm - 5.9dBi= -32.9dBm)	dB below Spec	Plot ref #
5180	30 - 1000 MHz	See Note				501
	1 to 5.15 GHz	4.13	-54.00	-32.9	21.1	502
	5.25 to 10 GHz	6.22	-47.33	-32.9	14.43	503
	10 GHz to 20 GHz	10.33	-44.50	-32.9	11.6	504
	20 GHz to 40 GHz	36.77	-44.50	-32.9	11.6	505
5260	30 - 1000 MHz	See Note				506
	1 to 5.25 GHz	4.21	-54.67	-32.9	21.77	507
	5.35 to 10 GHz	6.31	-46.17	-32.9	13.27	508
	10 GHz to 20 GHz	10.50	-39.33	-32.9	6.43	509
	20 GHz to 40 GHz	36.80	-43.17	-32.9	10.27	510
5320	30 - 1000 MHz	See Note				511
	1 to 5.25 GHz	5.09	-47.83	-32.9	14.93	512
	5.35 to 10 GHz	6.38	-49.00	-32.9	16.1	513
	10 GHz to 20 GHz	10.62	-53.50	-32.9	20.6	514
	20 GHz to 40 GHz	37.57	-44.33	-32.9	11.43	515
5745	30 - 1000 MHz	See Note				516
	1 to 5.725 GHz	4.60	-52.67	-32.9	19.77	517
	5.825 to 10 GHz	5.88	-51.33	-32.9	18.43	518
	10 GHz to 20 GHz	11.48	-38.83	-32.9	5.93	519
	20 GHz to 40 GHz	36.33	-44.17	-32.9	11.27	520
5765	30 - 1000 MHz	See Note				521
	1 to 5.725 GHz	4.61	-52.83	-32.9	19.93	522
	5.825 to 10 GHz	5.83	-49.00	-32.9	16.1	523
	10 GHz to 20 GHz	11.52	-34.83	-32.9	1.93	524
	20 GHz to 40 GHz	37.10	-44.00	-32.9	11.1	525
5805	30 - 1000 MHz	See Note				526
	1 to 5.725 GHz	4.65	-48.33	-32.9	15.43	527
	5.825 to 10 GHz	7.59	-52.67	-32.9	19.77	528
	10 GHz to 20 GHz	11.60	-42.50	-32.9	9.6	529
	20 GHz to 40 GHz	36.57	-43.17	-32.9	10.27	530

Note: This band was examined for radiated emissions during the digital device radiated emissions test.

Lower UNII band(s) emissions plots UUT Transmitting on 5.26 GHz

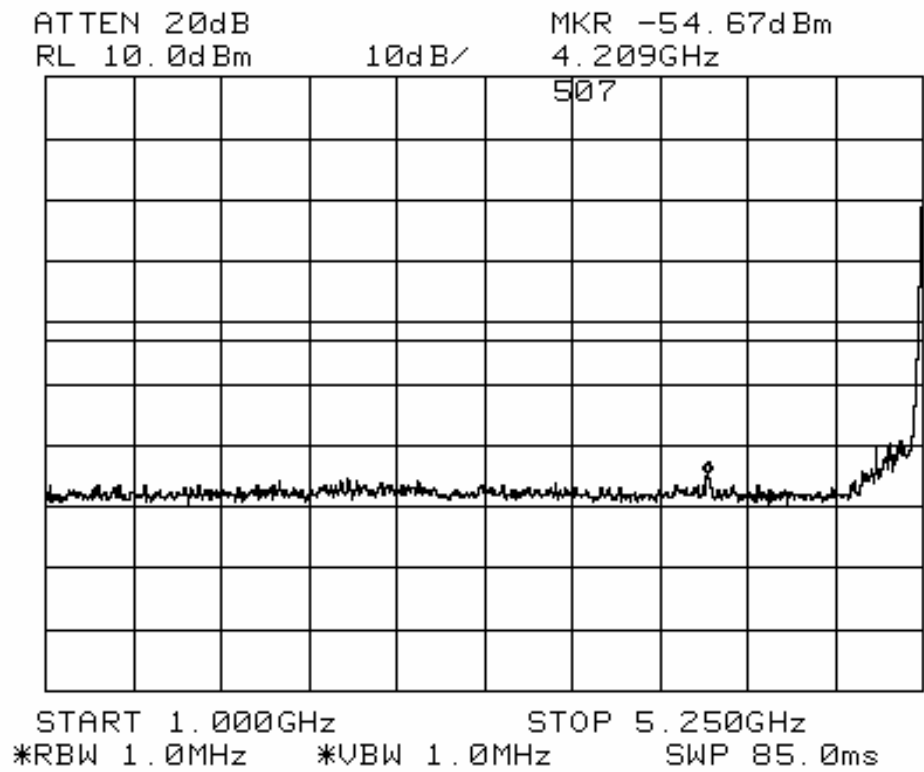
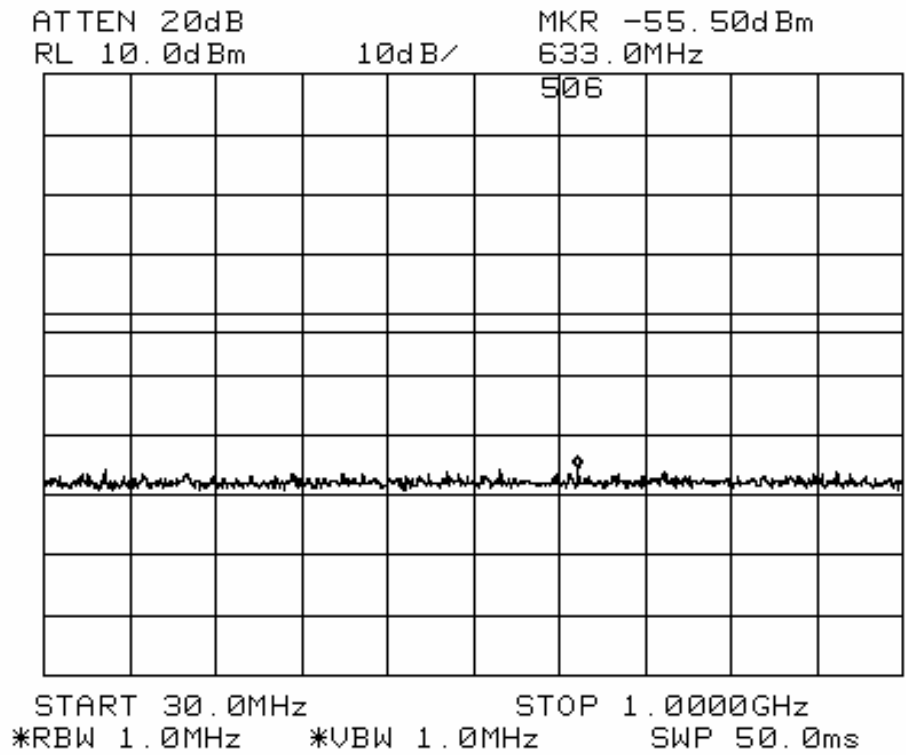

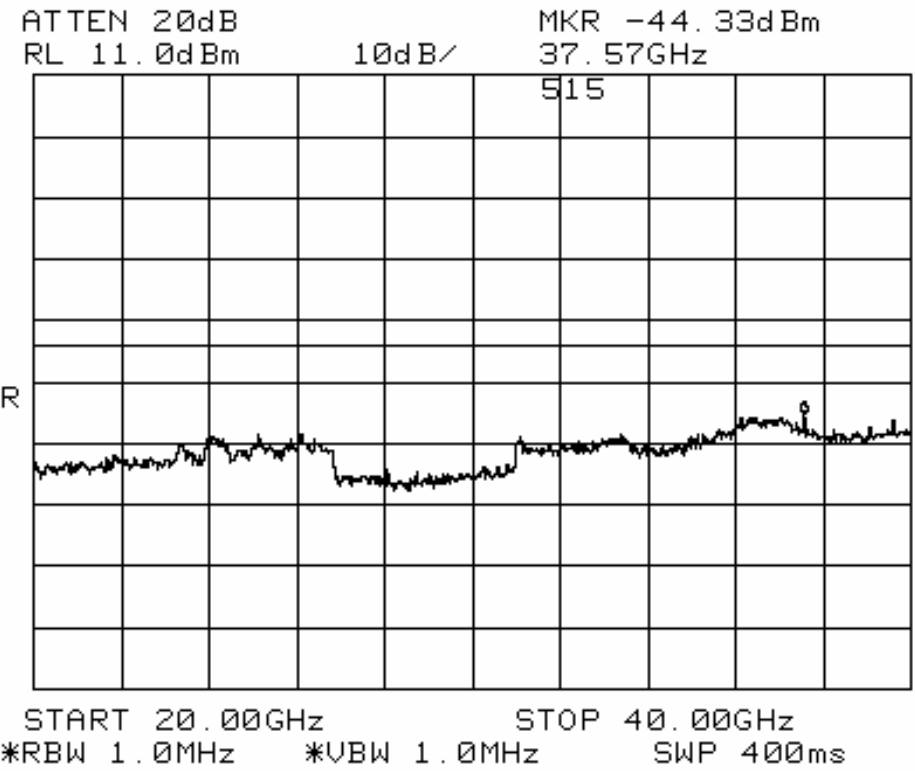
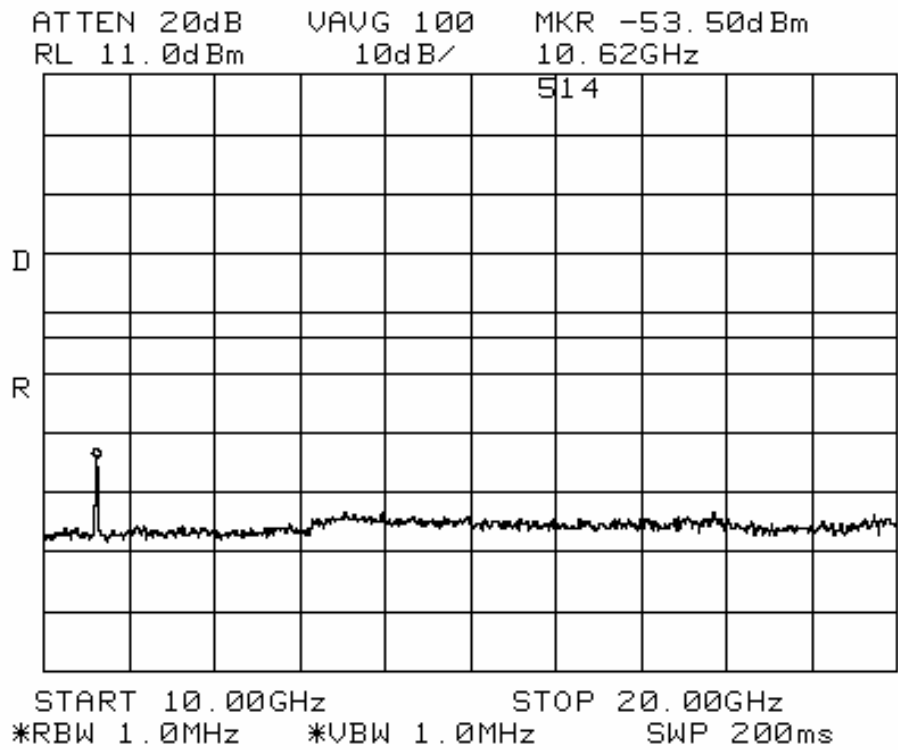

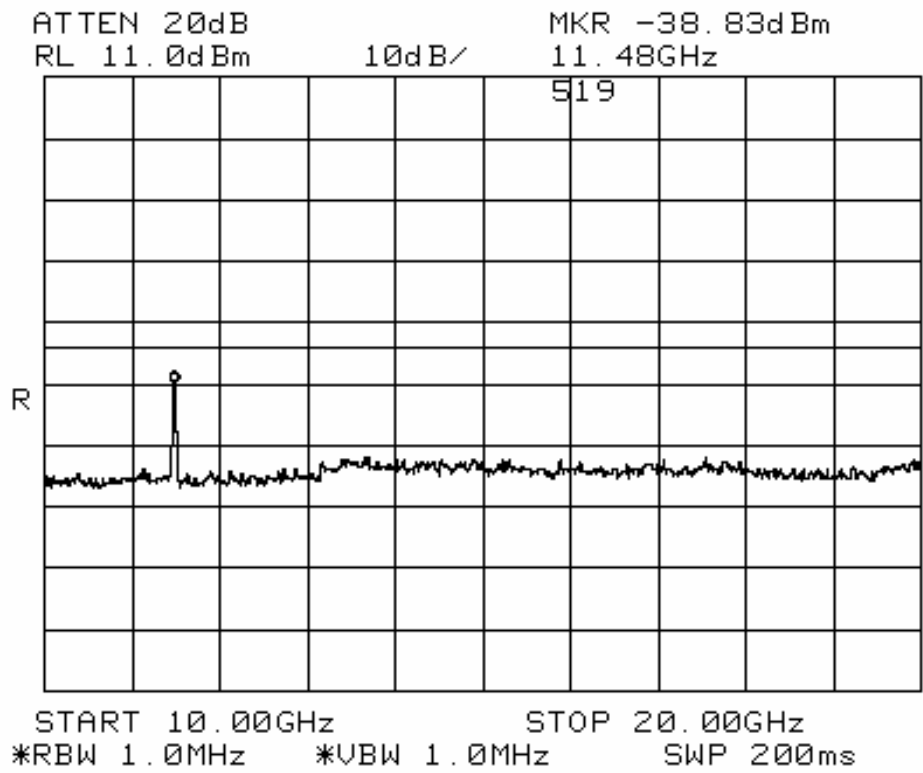
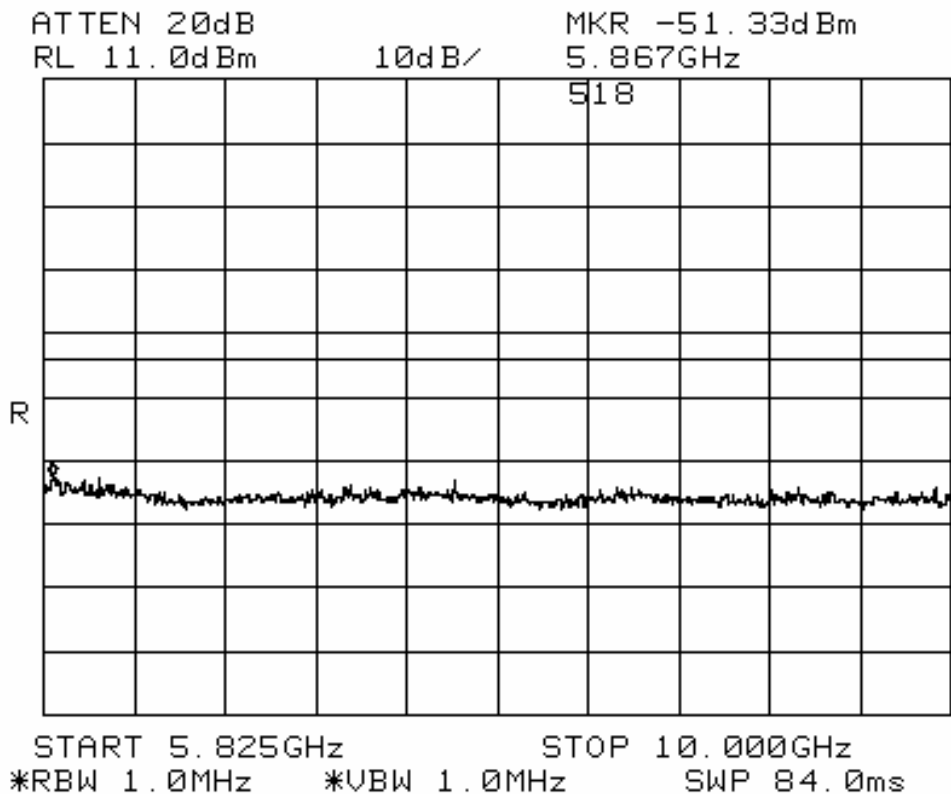

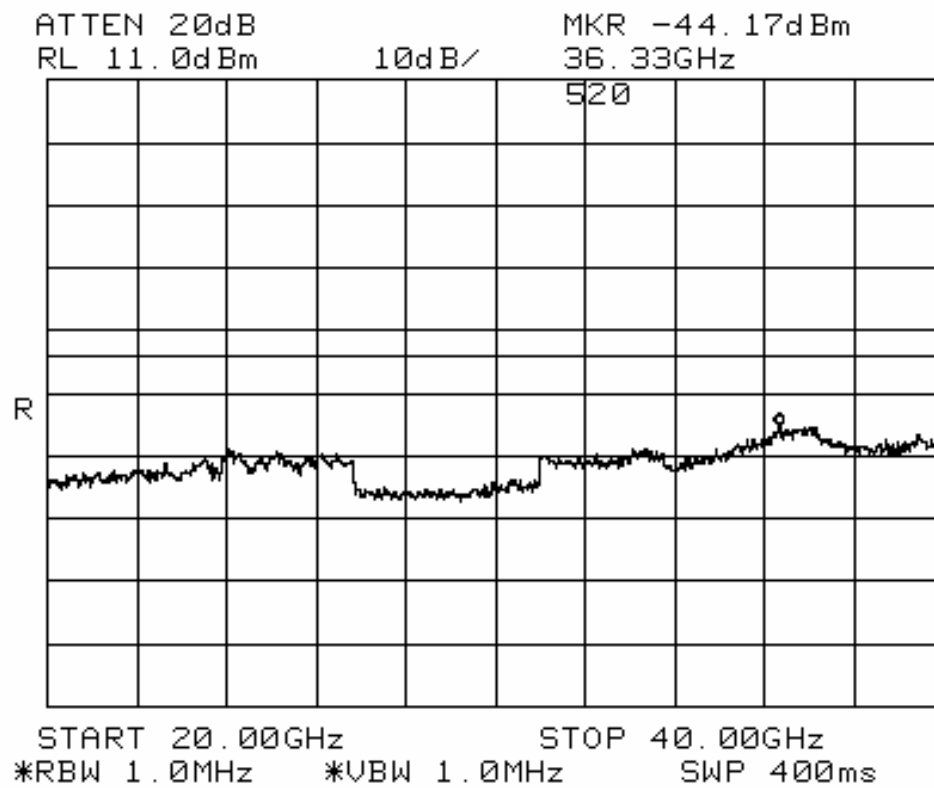

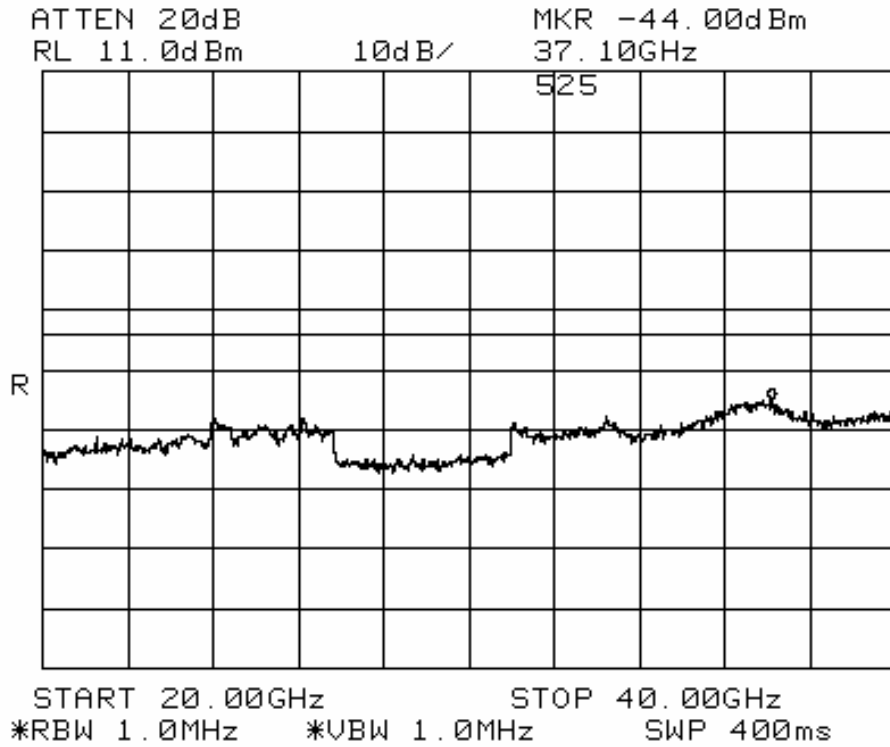

Upper UNII band(s) emissions plots
UUT Transmitting on 5.805 GHz

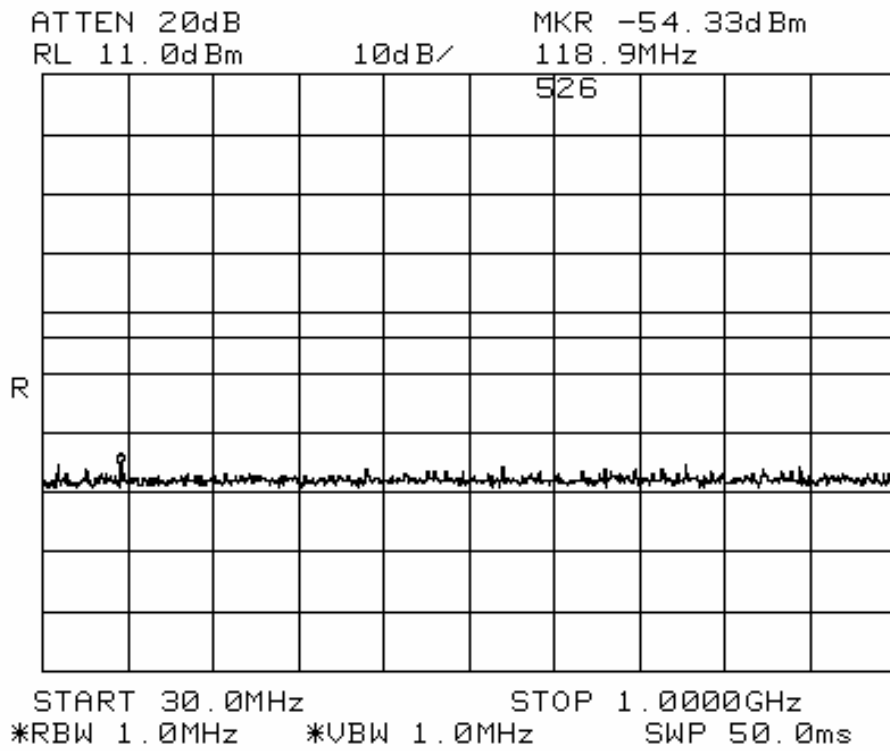

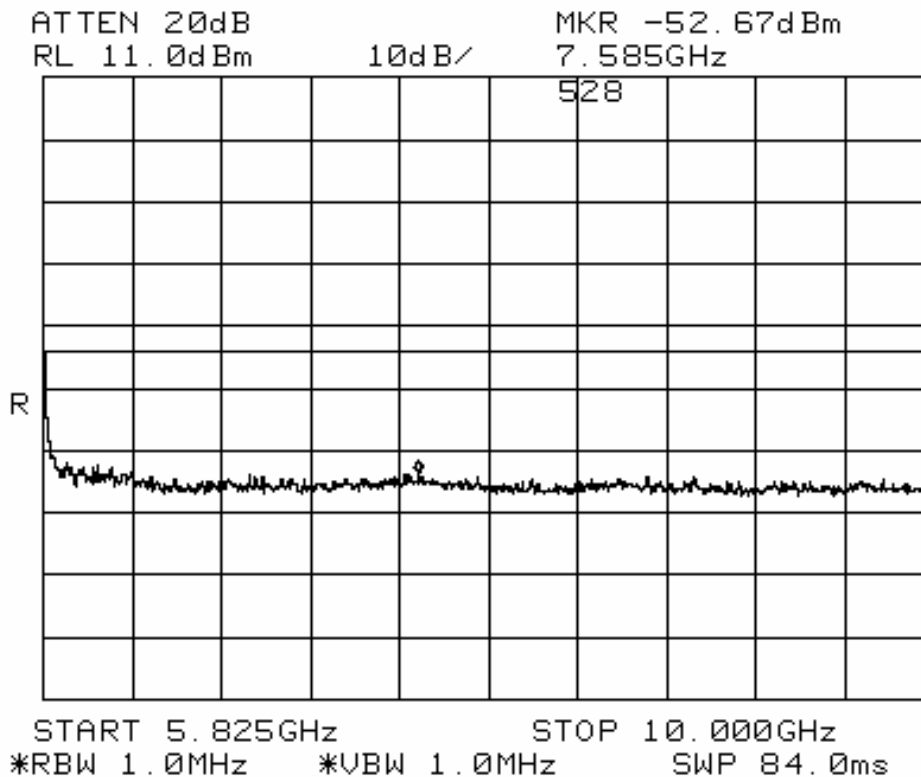
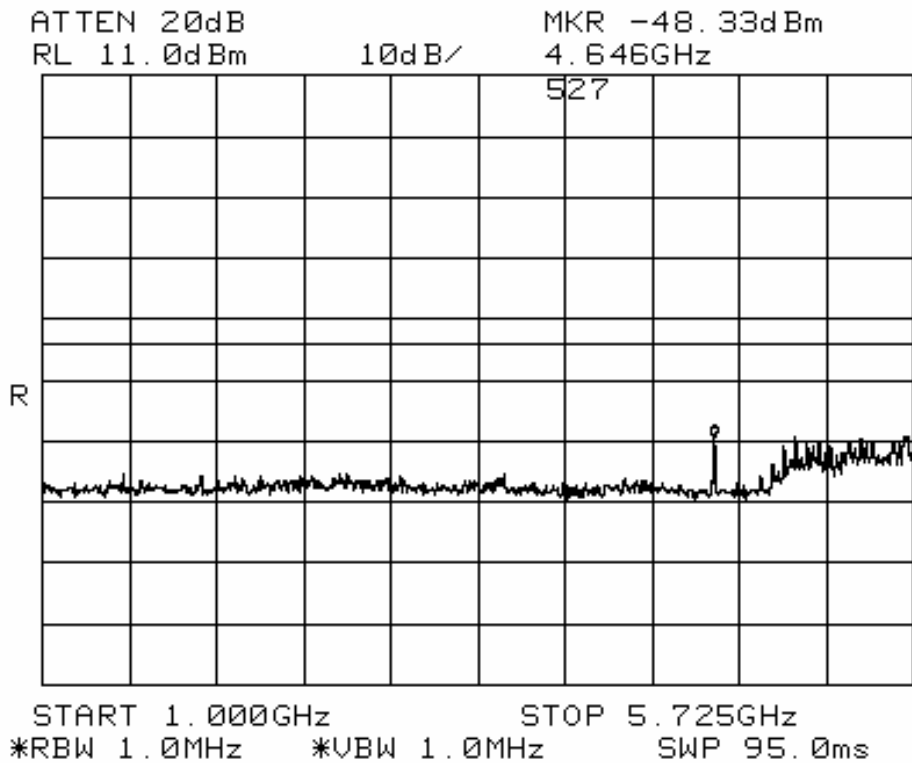

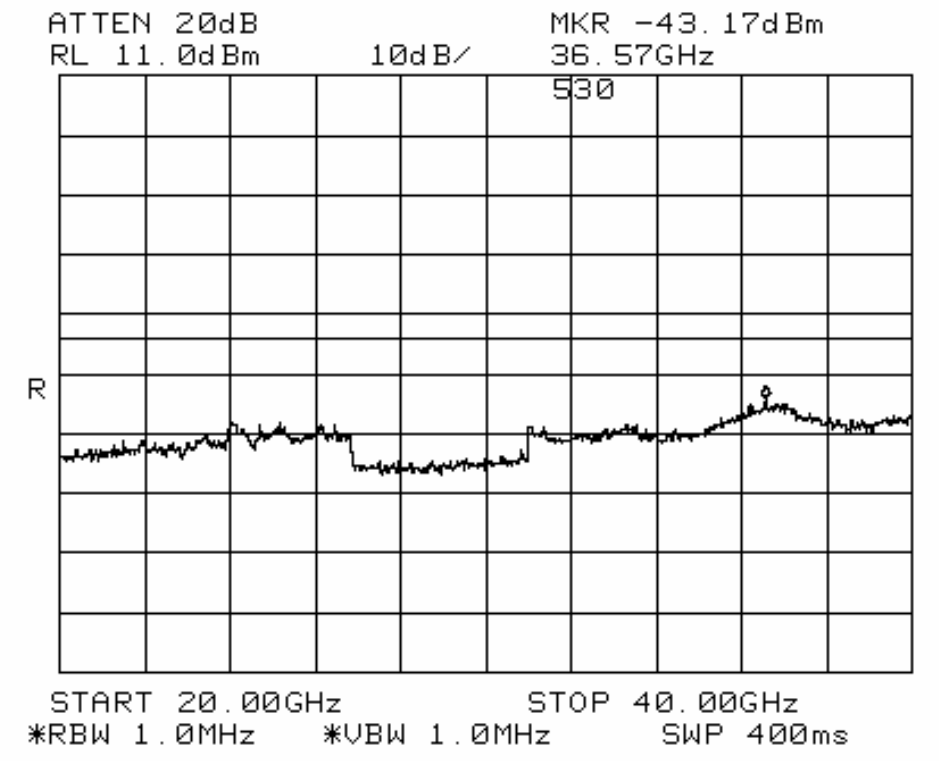
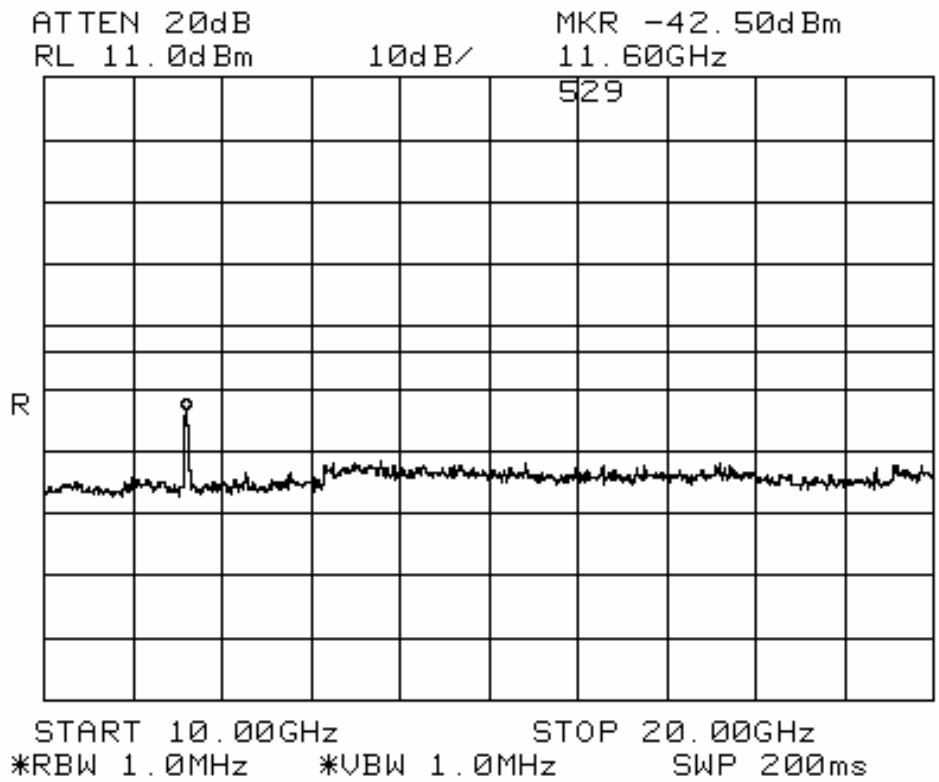

5.725 – 5.825 GHz bandedge

Specification

FCC Specifications: Paragraphs 15.407(b)(3)

Procedure:

For signals in the restricted bands immediately above and below the 5.725 to 5.825 GHz band, measurements were made of the antenna conducted power. The test was configured as shown in the Conducted RF test setup. The UUT was configured to transmit random data packets. The band 10 MHz immediately above and below the 5.735 – 5.825 GHz band was examined spurious emissions. This test was conducted on the low and high channels with the UUT configured to the appropriate power setting depending on the test channel.

. The EIRP was then calculated by adding the antenna gain (in dBi) to the measure power level with RBW = 1MHz, VBW = 1MHz, video averaging on.

Results:

Upper UNII band bandedge emissions summary

Channel	Frequency (MHz)	Frequency Range	Limit -17.0dBm-5.9dBi= -22.9dBm	Level at the band edge (dBm)	Delta dB Below Limit
149	5745	5.715 - 5.725 GHz	-22.9	-40.83	17.93
161	5805	5.825 - 5.835 GHz	-22.9	-48.50	25.60

Plots of the out of band emissions at the band edges are shown on the following page.

Plot of the 5,725 GHz lower band edge showing the peak @ -40.83dBm

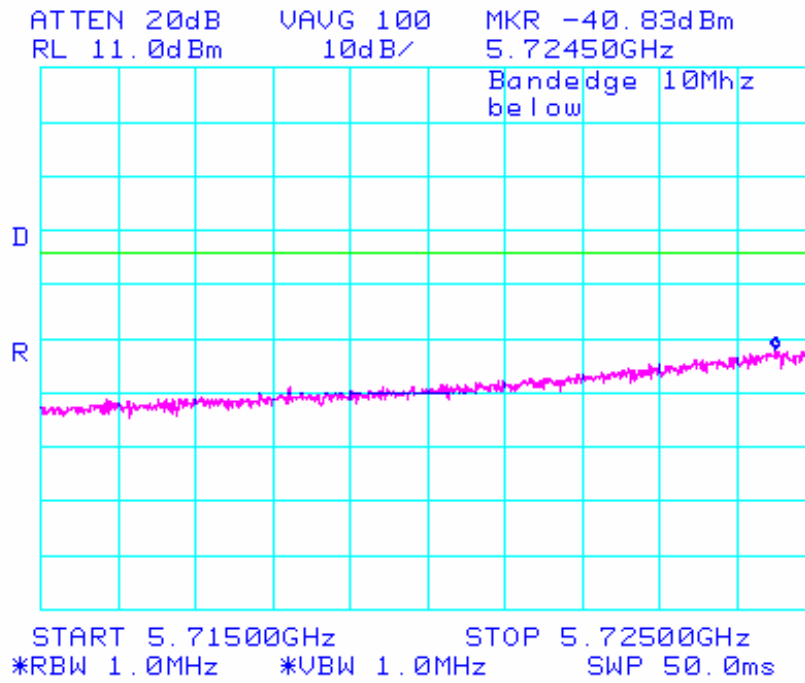

Plot of the 5,825 GHz upper band edge showing the peak @ -48.5dBm

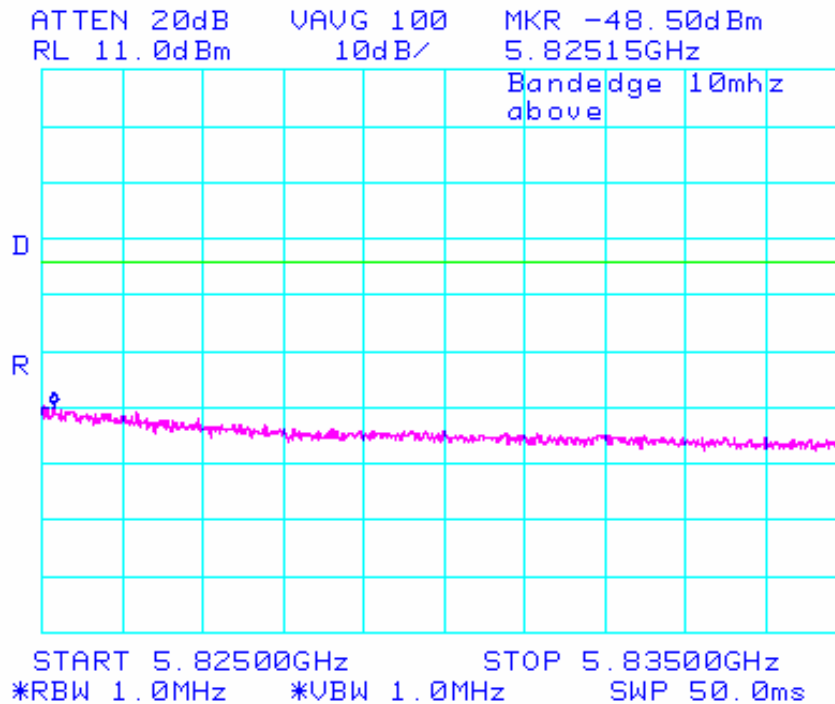

Peak Excursion

Specification

FCC Specifications: Paragraphs 15.407(a)(5)

Procedure:

The test equipment was configured as shown in the RF Conducted bench setup. The analyzer was set to an appropriate span to view the entire emission bandwidth. There were two traces made in order to determine the peak excursion. The following settings were used for the two traces. The delta between the two traces must be less than 13 dB

Trace 1: RBW = 1 MHz, VBW =3 MHz with peak detector and max-hold settings.

Trace 2: RBW = 1 MHz. Set VBW =300 kHz, set to Max Hold and allowed to settle for 60 seconds.

Results:

Frequency (MHz)	Peak Excursion (dB)	FCC Limit (dBm)
5805	1.80	17.0
5765	2.76	17.0
5745	2.57	17.0
5320	2.90	11.0
5260	2.76	11.0
5180	2.97	4.0

Peak Excursion = 1.8 dB. Frequency 5805 MHz

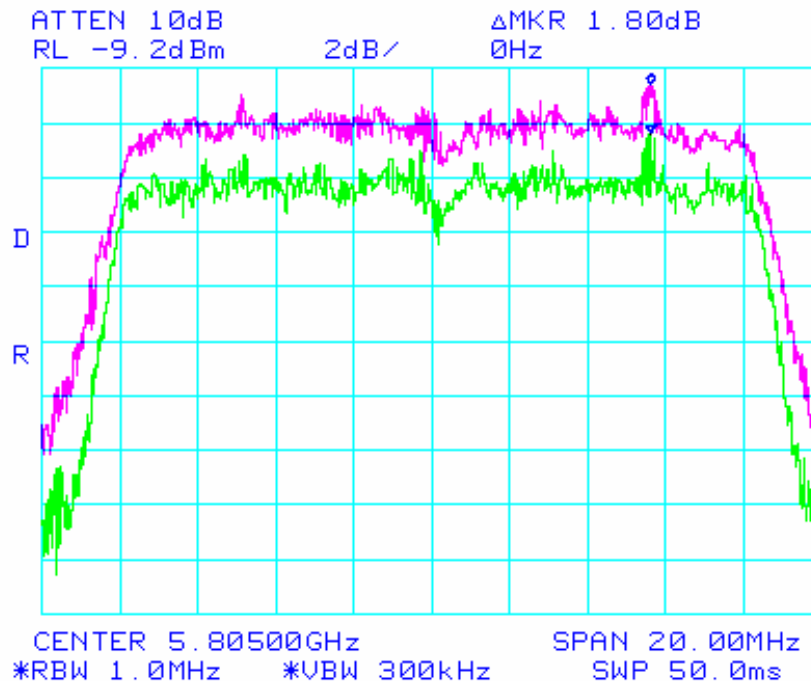

Peak Excursion = 2.76 dB. Frequency 5765 MHz

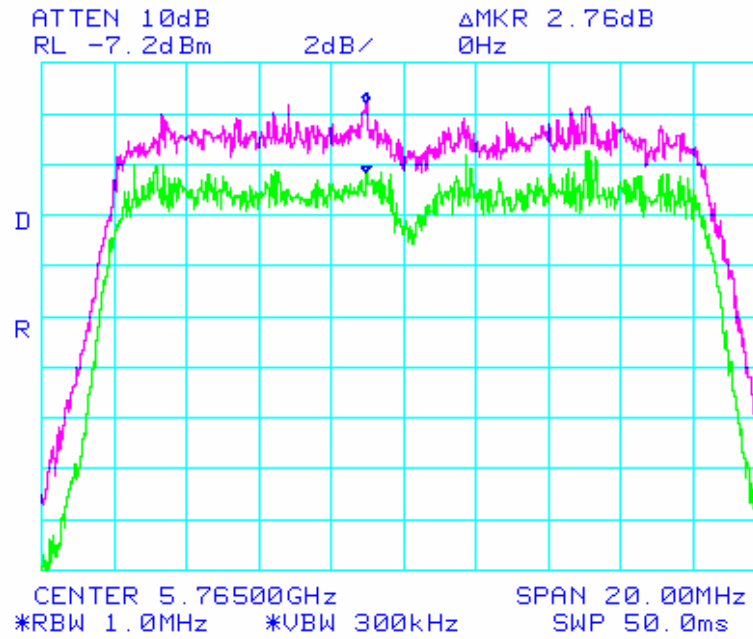

Peak Excursion = 2.57 dB. Frequency 5745 MHz

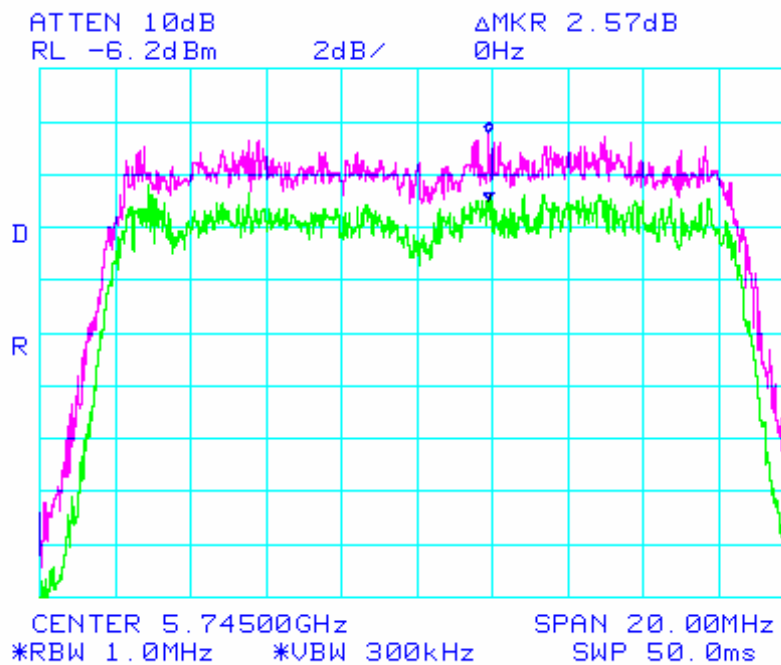

Peak Excursion = 2.97 dB. Frequency 5180 MHz

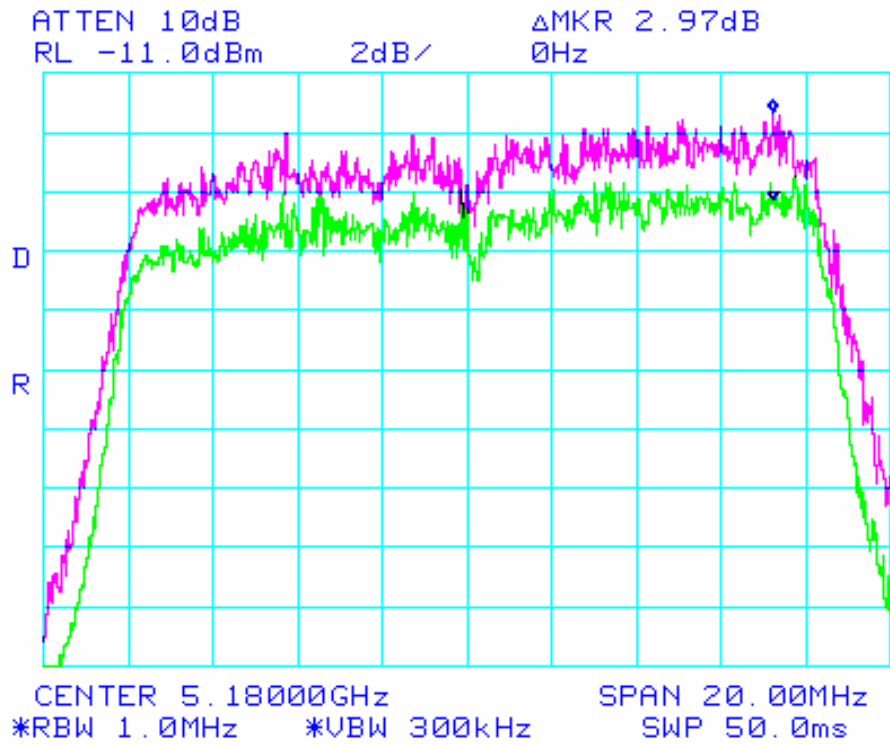

5 GHz Radiated Emissions in Restricted bands

Specification:

FCC Specification:

Paragraph 15.407(b)(6)

Procedure:

This test was conducted on a 3-meter open-air test site at Elliott Laboratories. The unit was placed on a rotating wooden table 80cm above the ground plane. A Horn antenna(s) were secured to a mast 3 meters away. The unit was tested at each of the Low, Mid and High channels. The UUT was running in the diagnostic mode and set to transmit random data. The transmit power was set to the settings outlined in the power setting table. The test equipment was configured as shown below.

The harmonics of the fundamental that fell within restricted bands were measured (See table 1 below). A high pass filter prior to the pre-amplifier was required to prevent the signal level of the fundamental frequency from overloading the front end of the spectrum analyzer and creating harmonics within the analyzer.

The EUT was rotated 360 degrees and the height of the antenna adjusted from 1 to 4 meters above the ground plane to determine the maximum level of the emission. The level of the harmonic emission was measured in two modes, "Peak" and "Average".

The spectrum analyzer reading was entered into a spreadsheet where correction factors (antenna factor, cable loss, pre-amplifier gain, HPF loss...) were then applied by Elliott Lab's Software to obtain a final corrected measurement.

This procedure was repeated for the low mid and high channels across the 5 GHz bands. The table below indicates the harmonics that fall within restricted bands.

Fund	Harmonic								
	2	3	4	5	6	7	8	9	10
5745	11490	17235	22980	28725	34470	40215	45960	51705	57450
5765	11530	17295	23060	28825	34590	40355	46120	51885	57650
5805	11610	17415	23220	29025	34830	40635	46440	52245	58050

15.407(b)(6) Harmonic test table

*NOTE: **RED** indicates a harmonic that falls within a restricted band, the harmonics in **gray** are NOT in restricted bands.*

Test Setup

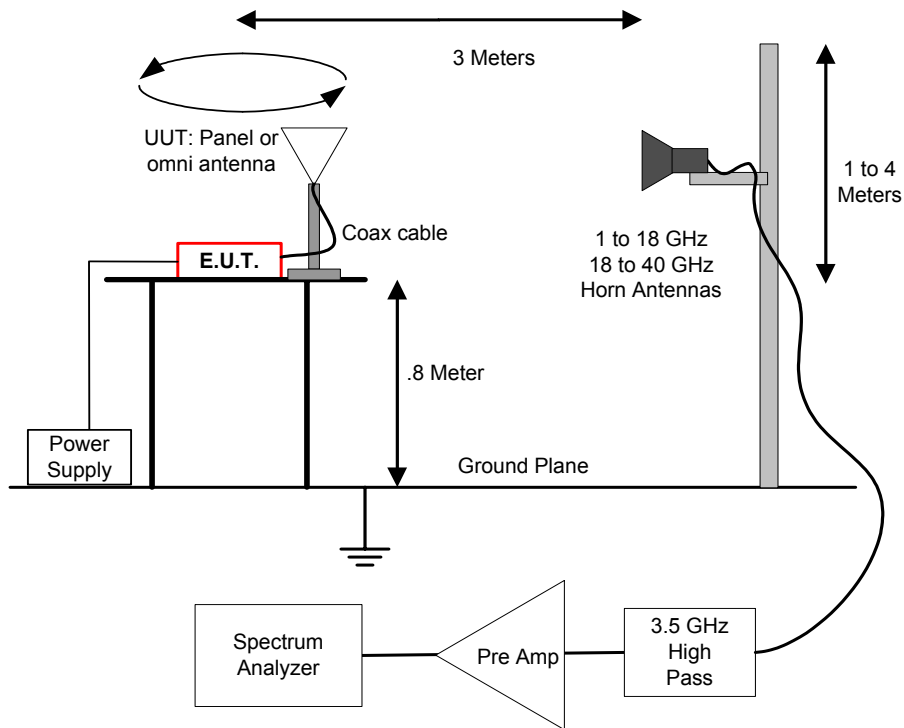

Radiated Emissions in Restricted Bands Test Setup

Support Equipment				
Description	Model number	FCC ID or SN	Manufacturer	Power Cable
Laptop	Armada E 500	P31000T4X20DC12N2	Compaq	Laptop PS
Test Software	Atheros Radio Test		Atheros	"Zip" cord

Test Conditions			
Temperature	17 C	Humidity:	40%
ATM pressure	1020 mBar	Grounding:	None
Tested By	J Martinez	Date of Test:	March 2003
Test Reference	FCC Part 15.205 IC Paragraph RSS210, 6.2.3 (c)		
Setup Method	ANSI C63.4		
Tested Range	1 GHz to 40 GHz		
Test Voltage	120 VAC / 60 Hz		
Modifications	No modifications were made to the unit		

Results:

There were some emissions detected during the test. The results are below. In some cases the emission was not within a restricted band. These emissions are highlighted in green

Frequency (MHz)	Level dBmV/m	Pol v/h	15.209 / 15.407 Limit Margin		Detector Pk/QP/Avg	Azimuth degrees	Height meters	Comments
LOW UNII Band EUT Xmitting on 5.18GHz Power setting 14								
10360.0	62.6	h	68.3	-5.7	Note 3	285	1.1	Note 3
15540.0	58.2	h	74.0	-15.8	Pk	42	1.1	Note 2
15540.0	45.7	h	54.0	-8.3	Avg	42	1.1	Note 2
10360.0	54.4	v	68.3	-13.9	Note 3	194	1.0	Note 3
15540.0	58.3	v	74.0	-15.7	Pk	60	1.0	Note 2
15540.0	46.0	v	54.0	-8.0	Avg	60	1.0	Note 2
LOW UNII Band EUT Xmitting on 5.26GHz Power setting 17								
15780.0	58.1	v	74.0	-15.9	Pk	0	1.0	Note 2
15780.0	46.3	v	54.0	-7.7	Avg	0	1.0	Note 2
10520.0	52.1	v	68.3	-16.2	Note 3	250	1.0	Note 3
15780.0	58.3	h	74.0	-15.7	Pk	284	1.0	Note 2
15780.0	46.6	h	54.0	-7.4	Avg	284	1.0	Note 2
10520.0	57.2	h	68.3	-11.1	Note 3	166	1.1	Note 3
LOW UNII Band EUT Xmitting on 5.32GHz Power setting 14								
10640.0	59.1	v	74.0	-14.9	Pk	207	1.1	Note 2
10640.0	46.3	v	54.0	-7.7	Avg	207	1.1	Note 2
15960.0	56.9	v	74.0	-17.1	Pk	63	1.0	Note 2
15960.0	45.0	v	54.0	-9.0	Avg	63	1.0	Note 2
10640.0	64.2	h	74.0	-9.8	Pk	133	1.0	Note 2
10640.0	50.3	h	54.0	-3.7	Avg	133	1.0	Note 2
15960.0	57.0	h	74.0	-17.0	Pk	349	1.0	Note 2
15960.0	45.2	h	54.0	-8.8	Avg	349	1.0	Note 2
UPPER UNII Band EUT Xmitting on 5.745GHz Power setting 13								
11490.0	65.4	h	74.0	-8.6	Pk	298	1.0	Note 2
11490.0	53.5	h	54.0	-0.5	Avg	298	1.0	Note 2
17235.0	56.4	h	74.0	-17.6	Pk	307	1.0	Note 2
17235.0	44.5	h	54.0	-9.6	Avg	307	1.0	Note 2
11490.0	56.5	v	74.0	-17.5	Pk	110	1.1	Note 2
11490.0	44.2	v	54.0	-9.8	Avg	110	1.1	Note 2
17235.0	57.0	v	74.0	-17.0	Pk	21	1.0	Note 2
17235.0	44.4	v	54.0	-9.6	Avg	21	1.0	Note 2
UPPER UNII Band EUT Xmitting on 5.765GHz Power setting 13								
11530.0	66.3	h	74.0	-7.7	Pk	331	1.1	Note 2
11530.0	53.9	h	54.0	-0.1	Avg	331	1.1	Note 2
17295.0	56.7	h	74.0	-17.3	Pk	289	1.1	Note 2
17295.0	44.6	h	54.0	-9.4	Avg	289	1.1	Note 2
11530.0	58.7	v	74.0	-15.3	Pk	126	1.2	Note 2
11530.0	46.4	v	54.0	-7.6	Avg	126	1.2	Note 2
17295.0	56.4	v	74.0	-17.6	Pk	0	1.0	Note 2
17295.0	44.5	v	54.0	-9.5	Avg	0	1.0	Note 2

Frequency	Level	Pol	15.209 / 15.407		Detector	Azimuth	Height	Comments
(MHz)	dBmV/m	v/h	Limit	Margin	Pk/QP/Avg	degrees	meters	
UPPER UNII Band EUT Xmitting on 5.805GHz Power setting 11								
11610.0	67.1	h	74.0	-6.9	Pk	124	1.0	Note 2
11610.0	53.5	h	54.0	-0.5	Avg	124	1.0	Note 2
17415.0	56.9	h	74.0	-17.1	Pk	0	1.0	Note 2
17415.0	44.6	h	54.0	-9.4	Avg	0	1.0	Note 2
11610.0	56.9	v	74.0	-17.1	Pk	244	1.1	Note 2
11610.0	44.8	v	54.0	-9.2	Avg	244	1.1	Note 2
17415.0	56.8	v	74.0	-17.2	Pk	22	1.1	Note 2
17415.0	44.9	v	54.0	-9.1	Avg	22	1.1	Note 2

Notes:

#2 Emission is within a restricted band.

Peak measurements: Resolution and Video BW: 1 MHz

Average Measurements: Resolution BW: 1MHz and Video BW: 10 Hz

#3 Emission is NOT within a restricted band.

Measurement settings: Resolution BW = 1MHz and VBW = 3MHz.

Video averaging on (100 samples).

Radiated Emissions in Restricted bands at the band edges.

Ending at 5.15 GHz and beginning at 5.35 GHz

Procedure

There are three steps to performing this test.

STEP 1: Make a radiated measurement of the fundamental signal with the UUT on the highest channel. This measurement is used using the peak and average RBW and VBW of 1MHz/1MHz and 1MHz/10Hz. This measured radiated level is then used as a reference and is referred to as the *Fundamental Reference Measurement* in the table below

STEP 2: A conducted measurement is made using narrower bandwidths (100 kHz) to determine a $-dBc$ (delta dB) level between the fundamental reference level and the actual level at highest point in the restricted band. This delta dB is then subtracted from the radiated field strength reference measurement made earlier.

STEP 3 A third and final conducted measurement is made to determine the apparent drop in fundamental carrier power when the RBW is narrowed from 1MHz (in the reference measurement) to 100kHz (for the delta dB measurement). This is referred to below as the “BW Delta”. This correction factor is only allowed in the highest emission in the restricted band is less than 2 “standard bandwidths” from the edge of the restricted band.

This measurement is made because it is the intent of the restricted band emission test to reference the measurement made in the restricted band to a radiated measurement made in a 1 MHz BW

This procedure is outline in FCC Public Notice DA 00-705, released on 30 March 2000 and is referred to as the “Marker-Delta Method”

The restricted bands that are of concern in the test are 4.5 – 5.15 GHz and 5.35 – 5.46GHz because these restricted bands are adjacent to one of the operating bands of the VAP.



The power setting of the access point during this test was as shown in the power settings table.

A summary of the test results for each antenna at its applicable setting is presented on the next page. Note that the BW delta correction was not applied to the restricted band edge at 5.35 because the unit was within specification without applying this additional correction.

5 GHz UNII Band Edge (Restricted band @5.15GHz)										
Pol	Fundamental Ref Msmt		dBc Msmt	RBW Delta	Radiated Level at Band Edge		Specification		Delta (dB below Limit)	
	Peak dbuv/m	Avg dbuv/m			Peak dBuv/m	Avg dBuv/m	Peak dBuv/m	Avg dBuv/m	Peak dBuv/m	Avg dBuv/m
Vert	114.2	103.7	49.13	9.469	55.60	45.10	74	54	18.4	8.9
Horz	108.3	97.4	49.13	9.469	49.70	38.80	74	54	24.3	15.2

5GHz UNII Band Edge (Restricted band @5.35 GHz)										
Chan	Fundamental Ref Msmt		dBc Msmt	RBW Delta	Radiated Level at Band Edge		Specification		Delta (dB below Limit)	
	Peak dbuv/m	Avg dbuv/m			Peak dBuv/m	Avg dBuv/m	Peak dBuv/m	Avg dBuv/m	Peak dBuv/m	Avg dBuv/m
Vert	116.8	106.6	46.2	9.231	61.37	51.17	74	54	12.63	2.83
Horz	108.5	98.9	46.2	9.231	53.07	43.47	74	54	20.93	10.53

Radiated Emissions Sample Calculations

Restricted band level (AVG) = AVG reference level - delta dB - BW Delta dB
Restricted band level (Peak) = Peak reference level - delta dB - BW Delta dB

Sample Calculation

106.6 dBuv - 46.2 dB - 9.231 = 51.17 dBuv
 54 dBuv - 51.17 = 2.83 dB margin

dBc measurement at the low band edge

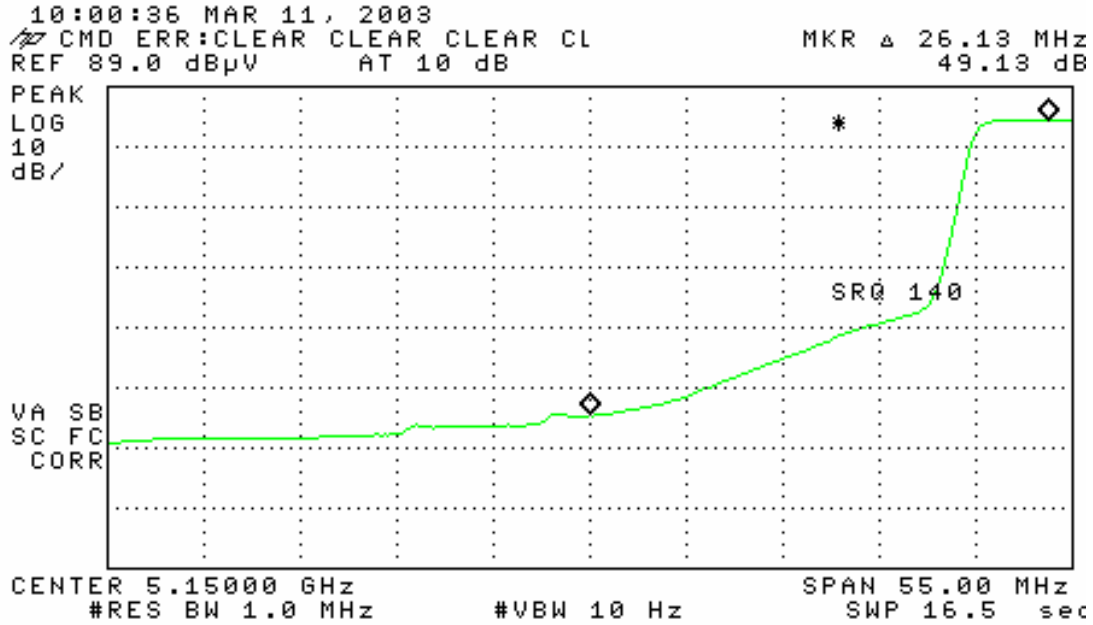

BW Delta measurement at the low band edge

Agilent 01:18:02 Apr 22, 2003

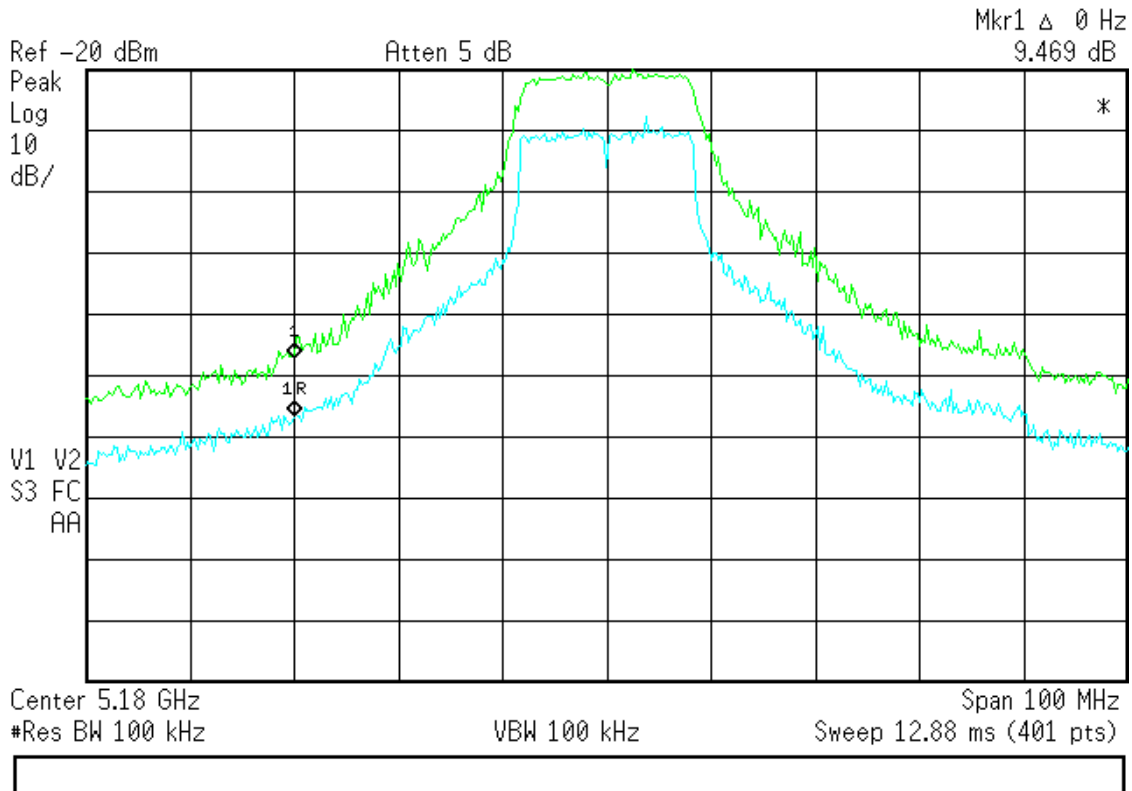

dBc measurement at the high band edge

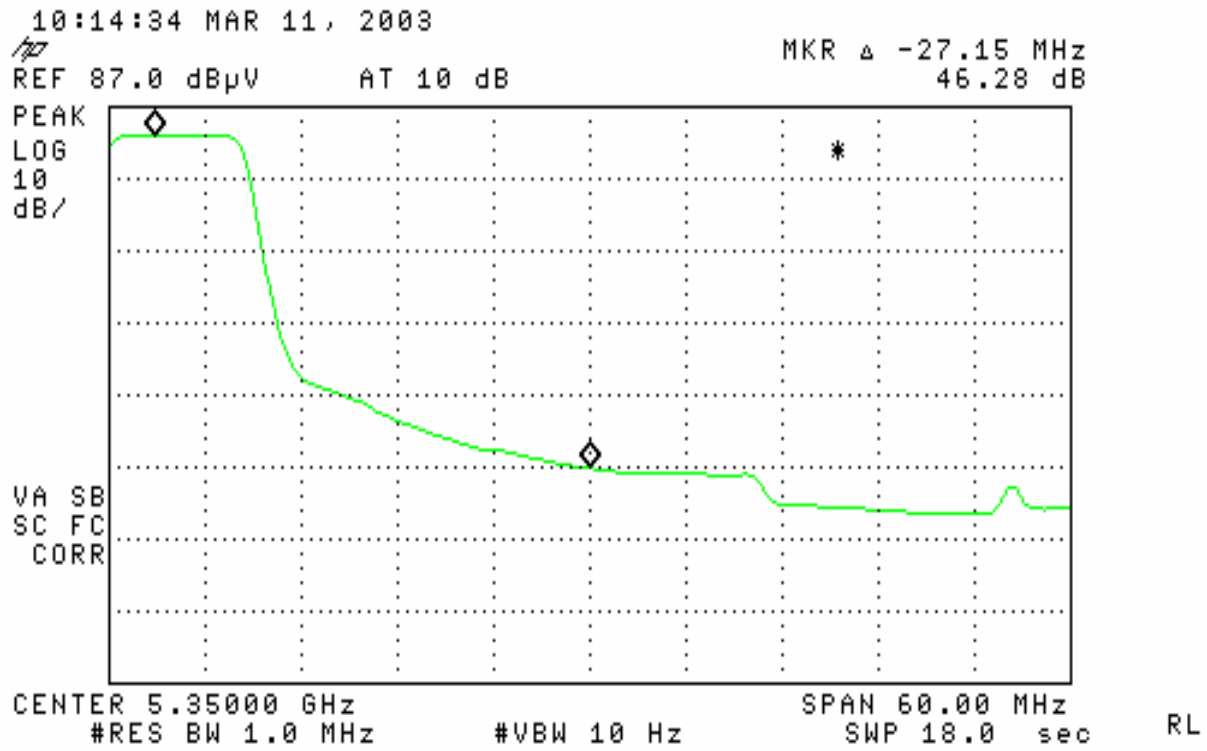

BW Delta measurement at the high band edge

Agilent 01:22:17 Apr 22, 2003

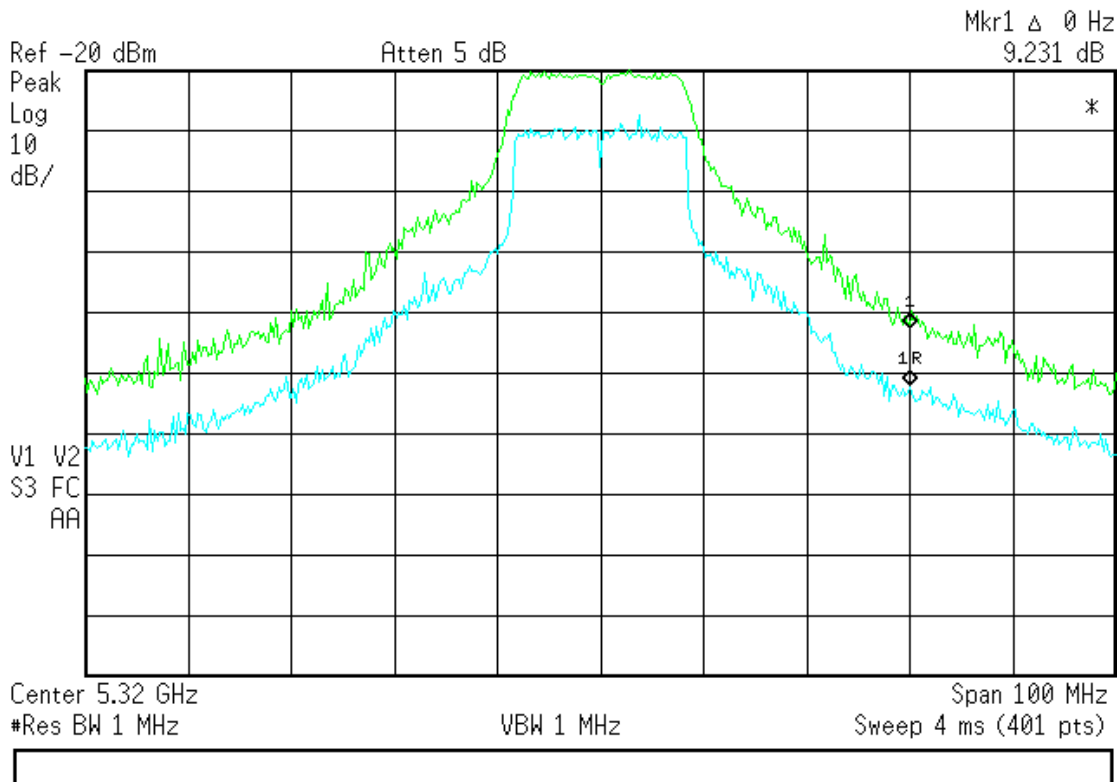

AC Line Conducted Emissions

Specification:

FCC Specification: Paragraph CISPR 22

Procedure:

The test was set up according to the guidelines set forth in EN55022:1998 and FCC Part 2 for AC Line Conducted Emissions. The measurement used a LISN line on each AC line and an EMI receiver. A peak scan was made over the measurement frequency range (150 kHz to 30 MHz). The highest peaks were then marked and re-measured and quasi-peaked and averaged.

The test was configured as shown below. The product was tested while running on 120 VAC @ 60 Hz .

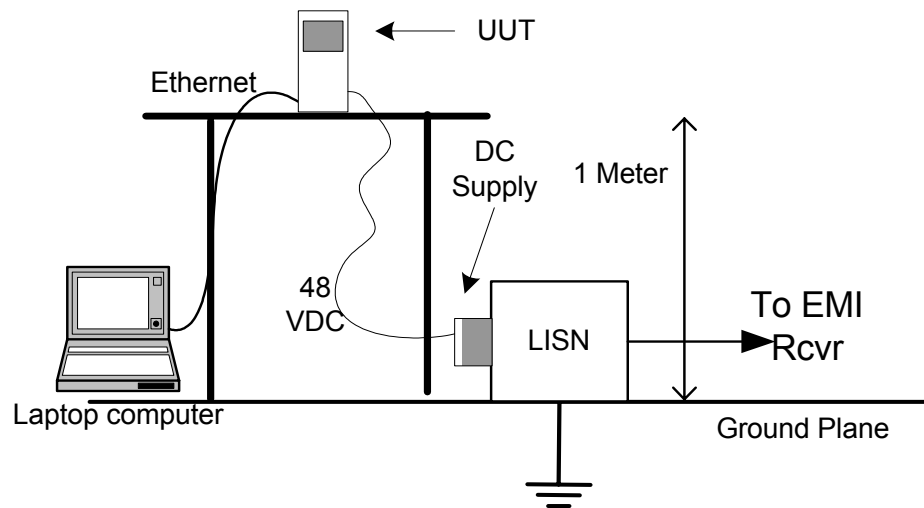

Results:

The "Quasi-peak" and the AVG results for the unit transmitting packets are contained in the table on the next page

Quasi Peak Test Results, CISPR 22 Class B limits

Freq (MHz)	Line	QP Level (dBuV)	Class B QP Limit (dBuV)	Delta (dB)	Freq (MHz)	Line	Class B QP Limit (dBuV)	Spec (dBuV)	Delta (dB)
	Neutral					Neutral			
25.83	Line	40.97	60	19.03	25.65.	Neutral	40.05	60	19.95
26.35	Line	47.89	60	12.11	26.35	Neutral	43.48	60	16.52
26.62	Line	41.25	60	18.75	26.62	Neutral	42.53	60	17.47
26.85	Line	46.92	60	13.08	26.84	Neutral	46.86	60	13.14
27.1	Line	46.91	60	13.09	27.1	Neutral	43.35	60	16.65
27.29	Line	58.75	60	1.25	27.59	Neutral	48.14	60	11.86
27.6	Line	46.98	60	13.02	27.86	Neutral	41.28	60	18.72
27.83	Line	48.61	60	11.39	28/09	Neutral	46.23	60	13.77
28.12	Line	41.46	60	18.54	28.32	Neutral	48.92	60	11.08
29.58	Line	45.29	60	14.71	28.57	Neutral	45.2	60	14.8

AVG Test Results, CISPR 22, Class B limits

Freq (MHz)	Line	AVG Level (dBuV)	Class B AVG limit (dBuV)	Delta (dB)	Freq (MHz)	Line	AVG Level (dBuV)	Class B AVG limit (dBuV)	Delta (dB)
	Neutral					Neutral			
25.83	Line	25.475	50	24.53	25.65.	Neutral	30.7	50	19.3
26.35	Line	30.23	50	19.77	26.35	Neutral	30.35	50	19.65
26.62	Line	31.44	50	18.56	26.62	Neutral	33.05	50	16.95
26.85	Line	34.257	50	15.74	26.84	Neutral	32.17	50	17.83
27.1	Line	29.59	50	20.41	27.1	Neutral	30.37	50	19.63
27.29	Line	36.118	50	13.9	27.59	Neutral	27.96	50	22.04
27.6	Line	28.64	50	21.36	27.86	Neutral	31.04	50	18.96
27.83	Line	29.9	50	20.1	28/09	Neutral	31.55	50	18.45
28.12	Line	34.03	50	15.97	28.32	Neutral	35.91	50	14.09
29.58	Line	32.43	50	17.57	28.57	Neutral	28.19	50	21.81