



110 Nortech Parkway
San Jose, California, 95134

FCC Part 15.247 Certification Application

Industrie Canada RSS210 Certification

**Addendum to
EMI Test Report
and
Technical Documentation
on
Airespace Access Point.
Model: 1200B**

FCC ID: QTZUSAP1200B

Prepared by:
David Waitt
202 Calvert Drive #217
Cupertino, Ca. 95014
david@waitt.us
(408) 832 7053

Table of Contents

Section	Page
General information-----	3
Detailed information-----	4
Results summary-----	5
Test facilities-----	6
Test Equipment-----	7
Test methods-----	8
Test Results-----	9
Maximum power at RF Output-----	10
Radiated emissions in restricted bands-----	11
Radiated emissions in restricted bands (Band Edge)-----	15

General Information

Unit(s) Under Test: **Access Point (AP)**
Model: **1200B**
Product Description: **IEEE 802.11 B Access point**

FCC ID: **QTZUSAP1200B**

Tested For: **Airespace**
110 Nortech Parkway
San Jose, Ca. 95134

Tested At: **Elliott Laboratories**
684 West Maude Ave
Sunnyvale, CA 94086

Tested By: **Juan Martinez, Sr. Test Engineer, Elliott Laboratories**
David Waitt, (Independent Consultant)

Test Specifications: **FCC CFR 47, Part 15.247, 2.4 GHz DSSS**

Test Date: **March 2003**

Requested Certification: **Part 15.247 Certification to allow use of 2.4 GHz external patch antennas with gains lower than 5dBi with the Airespace access point 802.11 products.**

Detailed Information

This is an addendum to the Airespace AP1200 B access point test report contained in the FCC part 15.247 certification applications. This addendum outlines the testing performed to authorize the use of external antennas with the 1200 B access point.

The additional testing performed to demonstrate compliance of the access point model 1200 B with the external antennas was:

Radiated emissions in restricted bands, including emissions at the band edge.

Airespace requests the authorization of patch antennas with gains less than or equal to 5dBi. Since this is the highest gain antenna Airespace intends on offering for use with the access point, testing was conducted on this antenna only.

The unit was tested with a Centurion 5dBi patch antenna. It is intended that the 5dBi patch and a lower gain 3dBi patch will be offered for use with the Airespace access point radio.

5dBi: Centurion PN 94149
3dBi Centurion PN 94150

Pictures and data sheets are included with this application.

It is anticipated that the Centurion antennas will be offered for use with the access point initially, however, Airespace may, at some point in the future offer similar antennas (type and gain) from different vendors.

As can be seen in the block diagram below, switching to the external antenna disconnects the internal antennas.

EXTERNAL CONNECTORS (15.203);

In order to comply with FCC Part 15.203, the Airespace Access point uses reverse TNC connectors for the external antenna connector. The Airespace access point actually has two external 2.4GHz connectors for the same reason that there are two internal 2.4 GHz antennas. Only one of these antennas is used at any given time. The access point rapidly switches between the two antennas and then uses the antenna that results in the best signal quality. There are several antenna configurations that are possible with the Airespace access point, they are outlined below, however, in every case, only ONE antenna is in use at any given time.

Config A: No external antennas, rapid switching between both internal antennas

Config B: Antenna connected to extern connector A. Used in conjunction with internal antenna B

Config C: Antenna connected to extern connector B. Used in conjunction with internal antenna A

Config D: Two external antennas connected for antenna diversity. Internal antennas disabled.

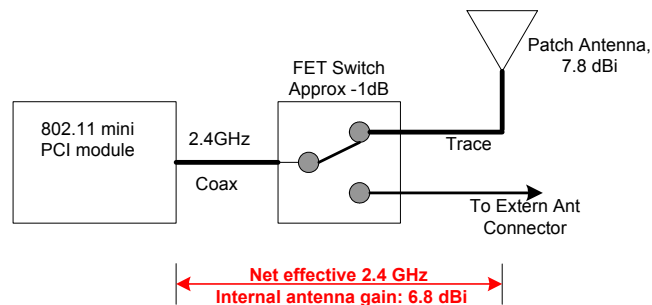

Test Results Summary

This report presents the results of the tests that verify compliance with FCC Part 15.247 while utilizing an external antenna.

A brief results summary of all the in this report is below.

Part 15 Paragraph	RSS-210 Paragraph	Test	Results
15.247(b)	6.2.2(o)(a) 3	Maximum Power Output at Antenna Terminal	15.29dBm 20.29 dBm EIRP
15.205	6.3(c)	Radiated Emissions in Restricted bands	8.7dBn spec min
15.205	6.3(c)	Radiated Emissions in Restricted bands (band-edge)	.6 dB in spec

Test Facilities

Many of the certification tests were performed at:

Elliott Labs
684 West Maude Ave
Sunnyvale, CA 94086

The tests performed at Elliott include:

- All radiated emissions tests required in FCC Part 15.205 for 2.4 and 5GHz.
- Out of band emissions (Conducted) (for 2.4 GHz)

General:

Final radiated test measurements were taken in March 2003 at the Elliott Laboratories Open Area Test Site #4.

The test site contains separate areas for radiated and conducted emissions testing. Pursuant to section 2.948 of the Rules, construction, calibration, and equipment data has been filed with the Commission.

The FCC recommends that ambient noise at the test site be at least 6 dB below the allowable limits. Ambient levels are below this requirement with the exception of predictable local TV, radio, and mobile communications traffic. The test site contains separate areas for radiated and conducted emissions testing. Considerable engineering effort has been expended to ensure that the facilities conform to all pertinent FCC requirements.

OATS:

The FCC has determined that radiation measurements made in a shielded enclosure are not suitable for determining levels of radiated emissions. Radiated emissions are performed in an open field environment. The test site is maintained free of conductive objects within the CISPR defined elliptical area incorporated in ANSI C63.4 Guidelines.

Antenna, Antenna Mast and Turntable

The Horn antennas that are used to measure radiated emissions above 1000MHz are mounted on a non-conductive antenna mast equipped with a motor drive to vary the antenna height.

ANSI C63.4 specifies that the test height above the ground plane shall be 80cm unless the equipment is intended to be floor mounted. During the radiated emissions tests the equipment is positioned on a motorized turntable in conformance with the ANSI requirement.

Equipment Lists

Instrument Calibration

All test equipment is regularly checked to ensure that performance is maintained in accordance with the manufacturer's specifications. All antennas are calibrated at regular intervals with respect to tuned half-wave dipoles. An exhibit of this report contains the list of test equipment used and calibration information.

All remaining "Conducted RF" tests were performed at by David Waitt in an Engineering lab utilizing calibrated Agilent test equipment. – See Additional test equipment list

The following test equipment was used to perform the testing

Elliott Test Equipment

Radiated Emissions, 1000 - 40,000 MHz, 14-Mar-03

Engineer: jmartinez

<u>Manufacturer</u>	<u>Description</u>	<u>Model #</u>	<u>Last Calibrated</u>	<u>Cal Due</u>
EMCO	Horn antenna, D. Ridge 1-18GHz (SA40 system antenna)	3115	4/20/2002	4/20/2003
Hewlett Packard	EMC Spectrum Analyzer 9kHz - 6.5GHz	8595EM	2/20/2003	2/20/2004
Hewlett Packard	Microwave EMI test system (SA40, 9Hz - 40GHz), system 2	84125C	4/2/2002	4/2/2003

Additional Test Equipment

<u>Item Desc.</u>	<u>Manufacturer</u>	<u>Model</u>	<u>S/N</u>	<u>Cal due date</u>
1. Peak Power meter	Agilent	4416A	GB40320299	7 July 03
2. Power Head	Agilent	E9327A	US40440899	16 Oct 03
3. Spectrum Analyzer	Agilent	E4404B	US40521093	3 Sep 03

Test Methods

The tests are performed at a low, middle and high channel of the applicable band. The typical frequencies used for the Part15.247 2.4 GHz tests are listed below. Unless otherwise noted, all testing was performed on these channels / frequencies

ISM 802.11 B 2400 – 2483.5 MHz	
Channel	Freq(MHz)
Low	2412
Mid	2437
High	2462

In order to comply with the “radiated emissions in restricted bands” requirements the transmit power had to be lowered on some of the channels at the edges of the operating band. The maximum power setting that allowed compliance with the radiated emissions requirements will be programmed into the configuration firmware of the access point ensuring that maximum possible power setting will be correct for each channel. Given that the access point will normally be operated at these power settings, these same settings were also used during the “bench top” conducted RF tests (Spectral density, bandwidth etc).

The transmit power setting for the 2.4 GHz ISM band 802.11 B channels used in the testing is shown in the table below. The power setting was +14 dBm on channels 1 and 11 to improve restricted band emissions at the band edges. All channels (in the 2.4 GHz band) other than 1 and 11 will be configured for +17 dBm power out.

Pout settings Vs. Channel	802.11a/b Channel	Frequency (MHz)	Tx Pout Set Point (dBm)
2.4 GHz ISM	1	2412.00	+14.00
	6	2437.00	+17.00
	11	2462.00	+14.00

Power setpoints / channel

Support Equipment				
Description	Model number	FCC ID or SN	Manufacturer	Power Cable
Laptop	Armada E 500	P31000T4X20DC12N2	Compaq	Laptop PS
Test Software	Atheros Radio Test		Atheros	
48VDC AC adapter	Generic		Generic	Standard Twin lead DC wire

NOTE: The “Power Injector” is simply a connector attached to wires “broken out” of the Ethernet cable. It is not really a piece of equipment.

Test Results

Detailed test procedures and test results are contained in the following sections. In cases where the test setup differs from the Conducted RF test setup shown earlier, the test setup is also presented.

Test Conditions			
Temperature	18 C	Humidity:	52%
ATM pressure	1012 mBar	Grounding:	None
Tested By	David Waitt	Date of Test:	March 2003
Test Reference	Refer to individual test results		
Tested Range	Test Dependent		
Test Voltage	48 VDC to the VAP		
Modifications	No modifications were made to the unit during the tests		

802.11 B Maximum RF Power Output at Antenna Terminals

Specifications:

FCC Specification: Paragraph: 15.247(b)

Procedure:

The test was configured as shown in the conducted RF test setup. The unit was tuned to the test channels and configured to transmit random data packets.

Because the unit will be operated at different power levels depending on the channel being used, the RF power out was measured at the appropriate power setting for the given test channel (see table above). The setting used for each channel is indicated in the results table below.

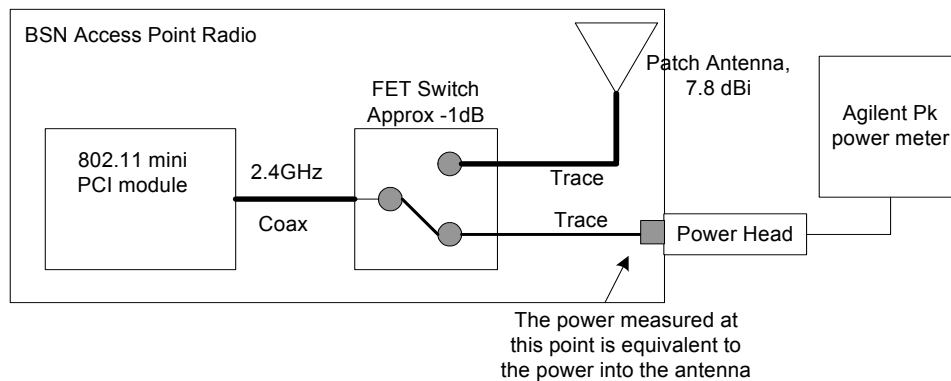

RF Transmit Power Result:

Given the RF output power previously measured, the EIRP with the external antenna is well within the allowable EIRP limits.

Pout settings Vs. Channel	802.11a/b Channel	Frequency (MHz)	Specification (dBm)	Measured Pout (Pk, dBm)	Measured Pout (Pk, Watts)
2.4 GHz ISM	1	2412.00	30	12.00	.01584
	6	2437.00	30	15.29	.03380
	11	2462.00	30	12.97	.01981

Given the power measured above, the EIRP of the VAP, for each channel tested, is listed below.

Pout settings Vs. Channel	802.11a/b Channel	Specification (dBm EIRP)	Measured Pout (Pk, dBm)	Ext Antenna Gain MAX dBi	Max Measured EIRP (dBm)	Delta (dB)
2.4 GHz ISM	1	36	12.00	5	17.0	19.00
	6	36	15.29	5	20.29	15.71
	11	36	12.97	5	17.97	18.03

ISM Radiated Emissions in Restricted bands with External Antenna

Specifications:

FCC Part 15 Paragraph 15.247(c)

Procedure:

This test was conducted on a 3-meter open-air test site at Elliott Laboratories. The unit was placed on a rotating wooden table 80cm above the ground plane. A 1 - 18 GHz Horn antenna was secured to a mast 3 meters away. The unit was tested at each of the Low, Mid and High channels. The UUT was running in the diagnostic mode and set to transmit CW at maximum power on each of the channels. The test equipment was configured as shown below.

The harmonics of the fundamental that fell within restricted bands (up to the tenth) were measured (See table 1 below). A high pass filter prior to the pre-amplifier was required to prevent the large signal level of the fundamental frequency from overloading the front end of the spectrum analyzer and creating harmonics within the analyzer.

The EUT was rotated 360 degrees and the height of the antenna adjusted from 1 to 4 meters above the ground plane to determine the maximum level of the emission. The level of the harmonic emission was measured in two modes, "Peak" and "Average".

The spectrum analyzer reading was entered into a spreadsheet where correction factors (antenna factor, cable loss, pre-amplifier gain, HPF loss...) were then applied by Elliott Lab's Software to obtain a final corrected measurement.

This procedure was repeated for the low, mid and high channels within the 2400-2485.5MHz band. The table below indicates the harmonics that fall within restricted bands.

FUND	Harmonic (MHz)								
	2	3	4	5	6	7	8	9	10
2412	4824	7236	9648	12060	14472	16884	19296	21708	24120
2437	4874	7311	9748	12185	14622	17059	19496	21933	24370
2462	4924	7386	9848	12310	14772	17234	19696	22158	24620

15.205 Harmonic test tables

NOTE: RED indicates a harmonic that falls within a restricted band and is subject to 15.205. The harmonics in black are NOT in restricted bands and are subject to 15.209

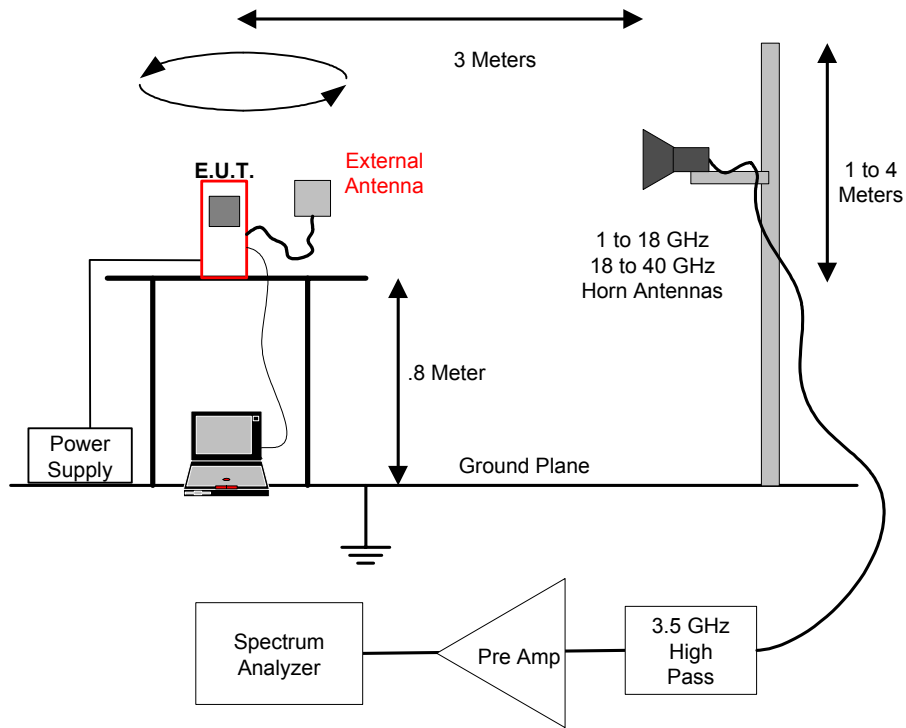

Radiated Emissions in Restricted Bands Test Setup

Support Equipment

Description	Model number	FCC ID or SN	Manufacturer	Power Cable
Laptop	Armada E 500	P31000T4X20DC12N2	Compaq	Laptop PS
Test Software	Atheros Radio Test		Atheros	
48VDC AC adapter	Generic		Generic	Standard Twin lead DC wire

Test Conditions

Temperature	19 C	Humidity:	39%
ATM pressure	1020 mBar	Grounding:	None
Tested By	J Martinez Elliott Labs	Date of Test:	March 2003
Test Reference	FCC Part 15.205 IC Paragraph RSS210, 6.2.3 (c)		
Setup Method	ANSI C63.4		
Tested Range	1 GHz to 24 GHz		
Test Voltage	120 VAC / 60 Hz		
Modifications	No modifications were made to the unit		

Results: Radiated emission with the 5 dBi external patch antenna**Low Channel: 2412 MHz**

Frequency MHz	Level dBmV/m	Pol v/h	15.209 / 15.247		Detector Pk/QP/Avg	Azimuth degrees	Height meters	Comments
			Limit	Margin				
4824.000	54.3	h	74.0	-19.8	Pk	219	1.5	
4824.000	40.7	h	54.0	-13.3	Avg	219	1.5	
12060.00	56.8	h	74.0	-17.2	Pk	316	1.0	Noise Floor
12060.00	45.0	h	54.0	-9.0	Avg	316	1.0	Noise Floor
14472.00	58.3	h	74.0	-15.7	Pk	300	1.0	Noise Floor
14472.00	45.2	h	54.0	-8.8	Avg	300	1.0	Noise Floor
4824.000	53.3	v	74.0	-20.7	Pk	6	1.0	
4824.000	40.1	v	54.0	-13.9	Avg	6	1.0	
12060.00	54.2	v	74.0	-19.8	Pk	360	1.0	Noise Floor
12060.00	42.8	v	54.0	-11.2	Avg	360	1.0	Noise Floor
14472.00	58.3	v	74.0	-15.8	Pk	45	1.0	Noise Floor
14472.00	45.3	v	54.0	-8.7	Avg	45	1.0	Noise Floor
Note 1:	For emissions in restricted bands, the limit of 15.209 was used. For all other emissions, the limit was set 20dB below the level of the fundamental.							

Mid Channel: 2437 MHz

Frequency MHz	Level dBmV/m	Pol v/h	15.209 / 15.247		Detector Pk/QP/Avg	Azimuth degrees	Height meters	Comments
			Limit	Margin				
4874.000	56.3	h	74.0	-17.7	Pk	340	1.7	
4874.000	43.4	h	54.0	-10.6	Avg	340	1.7	
7311.00	50.7	h	74.0	-23.3	Pk	339	1.1	
7311.00	38.0	h	54.0	-16.0	Avg	339	1.1	Noise Floor
12185.00	56.2	h	74.0	-17.8	Pk	202	1.1	Noise Floor
12185.00	44.0	h	54.0	-10.0	Avg	202	1.1	Noise Floor
4874.000	58.5	v	74.0	-15.5	Pk	45	1.0	
4874.000	45.0	v	54.0	-9.0	Avg	45	1.0	
7311.00	52.9	v	74.0	-21.1	Pk	239	1.0	
7311.00	43.5	v	54.0	-10.5	Avg	239	1.0	
12185.00	54.7	v	74.0	-19.3	Pk	64	1.0	Noise Floor
12185.00	43.7	v	54.0	-10.3	Avg	64	1.0	Noise Floor
Note 1:	For emissions in restricted bands, the limit of 15.209 was used. For all other emissions, the limit was set 20dB below the level of the fundamental.							

High Channel: 2462 MHz

Frequency MHz	Level dBmV/m	Pol v/h	15.209 / 15.247		Detector Pk/QP/Avg	Azimuth degrees	Height meters	Comments
			Limit	Margin				
4874.000	56.3	h	74.0	-17.7	Pk	340	1.7	
4874.000	43.4	h	54.0	-10.6	Avg	340	1.7	
7311.00	50.7	h	74.0	-23.3	Pk	339	1.1	
7311.00	38.0	h	54.0	-16.0	Avg	339	1.1	Noise Floor
12185.00	56.2	h	74.0	-17.8	Pk	202	1.1	Noise Floor
12185.00	44.0	h	54.0	-10.0	Avg	202	1.1	Noise Floor
4874.000	58.5	v	74.0	-15.5	Pk	45	1.0	
4874.000	45.0	v	54.0	-9.0	Avg	45	1.0	
7311.00	52.9	v	74.0	-21.1	Pk	239	1.0	
7311.00	43.5	v	54.0	-10.5	Avg	239	1.0	
12185.00	54.7	v	74.0	-19.3	Pk	64	1.0	Noise Floor
12185.00	43.7	v	54.0	-10.3	Avg	64	1.0	Noise Floor
Note 1:	For emissions in restricted bands, the limit of 15.209 was used. For all other emissions, the limit was set 20dB below the level of the fundamental.							

NOTES: For emissions in restricted bands, the limit of 15.209 was used. For all other emissions, the limit was set 20dB below the level of the fundamental. No emission detected above 15GHz.

Restricted Band Peak Measurements: Resolution and Video BW: 1 MHz

Restricted Band Average Measurements: Resolution Bw: 1MHz and Video Bw: 10 Hz.

All other measurements, RBW = 1MHz and VBW = 3MHz, video averaging on (100 samples).

Radiated Emissions in the Restricted bands near the operating band (Band-Edge)

Since this is an 802.11 A / B product, there are three instances where there is an adjacent restricted band next to the operating band.

- The restricted that ends at 5.15 GHz where the UNII band begins. (UNII Report)
- The restricted band that begins where the UNII band ends at 5.35 GHz (UNII Report)
- The restricted band that begins at 2.4835 GHz where the ISM band ends

Procedure

There are three steps to performing this test. The first involves making a radiated measurement of the fundamental signal with the UUT on the operating channel closest to the edge of the band. This measurement is made using the peak and average RBW and VBW of 1MHz/1MHz and 1MHz/10Hz. This measured radiated level is then used as a “fundamental reference” level

Then, a second measurement is made using narrower bandwidths (100 kHz) to determine a –dBc (delta dB) level between the fundamental level (measured in a 100 kHz BW) and the highest level within the restricted band near the operating band.

A third and final measurement is made to determine the apparent drop in fundamental carrier power when the RBW is narrowed from 1MHz (in the reference measurement) to 100kHz (for the delta dB measurement). This is referred to below as the “BW Delta”. This correction factor is only allowed in the highest emission in the restricted band is less than 2 “standard bandwidths” from the edge of the restricted band.

This measurement is made because it is the intent of the restricted band emission test to reference the measurement made in the restricted band to a radiated measurement made in a 1 MHz BW

The level of the emission in the restricted band is then calculated using the formulas below

<p>Restricted band level (AVG) = AVG reference level - delta dB - BW Delta dB Restricted band level (Peak) = Peak reference level - delta dB - BW Delta dB</p>
--

2.400 ISM Band Edge (Restricted band @ 2.390GHz)										
Pol	Fundamental Ref Msmt		dBc Msmt	BW Delta Msmt	Radiated Level at Band Edge		Specification		Delta	
	Peak	Avg			Peak	Avg	Peak	Avg	Peak	Avg
	dbuv/m	dbuv/m	dBc	dB	dBuv/m	dBuv/m	dBuv/m	dBuv/m	dBuv/m	dBuv/m
Vert	112.4	106.2	49.53	8.44	54.43	48.23	74	54	19.57	5.77
Horz	102.5	95.6	49.53	8.44	44.53	37.63	74	54	29.47	16.37
2.4835 ISM Band Edge (Restricted band @ 2.4835 GHz)										
Chan	Fundamental Ref Msmt		dBc Msmt	BW Delta msmt	Radiated Level at Band Edge		Specification		Delta	
	Peak	Avg			Peak	Avg	Peak	Avg	Peak	Avg
	dbuv/m	dbuv/m	dBc	dB	dBuv/m	dBuv/m	dBuv/m	dBuv/m	dBuv/m	dBuv/m
Vert	116.8	109.7	51.6	4.7	60.5	53.4	74	54	13.5	0.6
Horz	106.1	99.2	51.6	4.7	49.8	42.9	74	54	24.2	11.1

Radiated emissions at band edge sample calculation:

Emission Level = Fund Ref Msmt – Delta msmt – RBW Delta Msmt

Example: 109.7dBuV/m – 51.6dB – 4.7dB = 53.4dBuv/m
 54dBuv/m – 53.4dBuv/m = .6dB

Radiated Emissions Sample Calculations

Receiver readings are compared directly to the specification limit. The receiver internally corrects for cable loss, preamp gain and antenna factor. The calculations are in reverse from the signal flow, meaning that cable loss is actually added to the reading and amplification is subtracted. Antenna factor is a measure of the conversion of the voltage at the coaxial connector to the field strength at the antenna elements. A distance factor, for the electric field is calculated using the following formula

$$F_d = 20 \text{ Log}_{10} (D_m/D_s)$$

Where:

F_d = Distance Factor

D_m = Measurement distance in meters

D_s = specification distance in meters

Measurement distance is the distance at which the measurements were taken and the specification distance is the distance at which the specification limit is based.

The margin of a given emissions peak relative to the limit is calculated as follows:

$$R_c = R_r + F_d$$

and

$$M = R_c - L_s$$

Where :

R_r = Relative reading in dBuV/m

F_d = Distance Factor

R_c = Corrected reading in dBuV/m

L_s = specification Limit in dBuV/m

M = Margin in dB relative to the spec.



110 Nortech Parkway
San Jose, California, 95134

Airespace Certification Application

Appendix

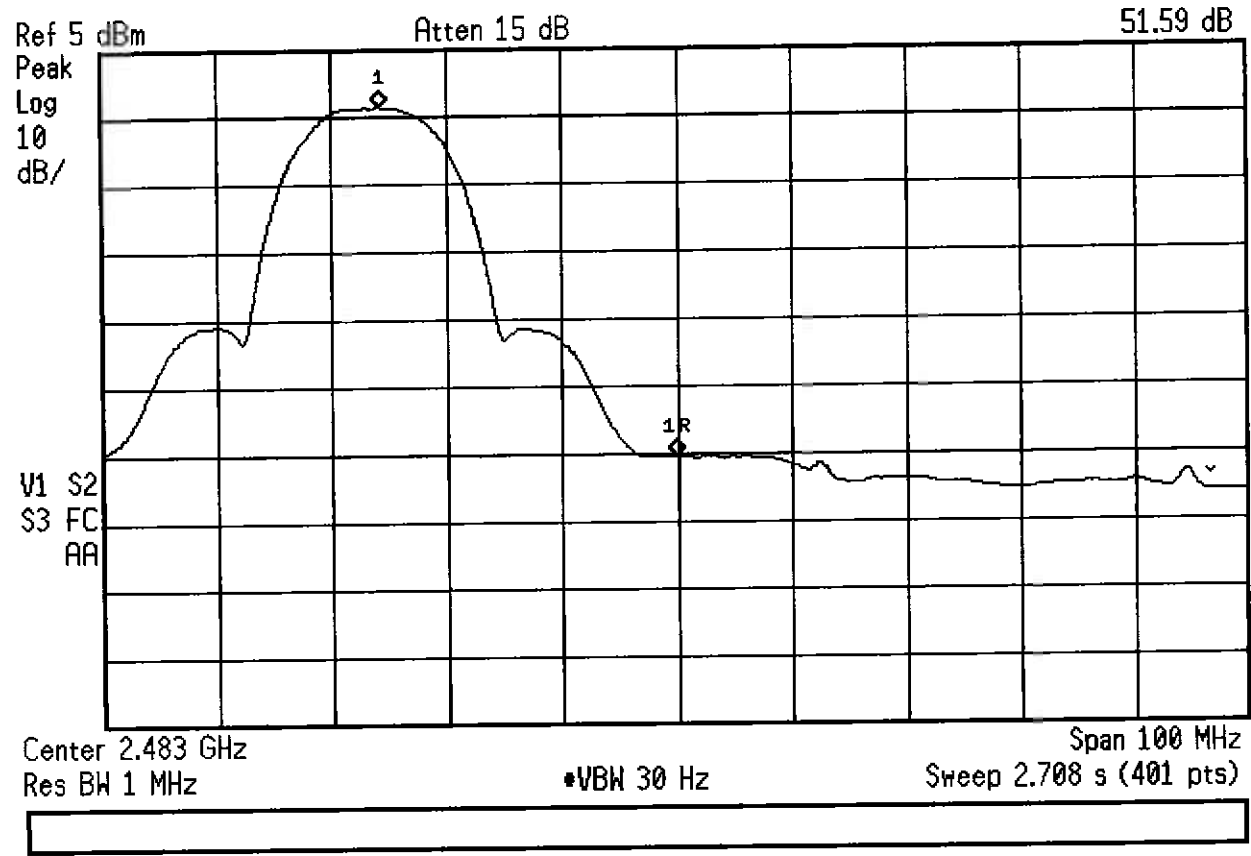

RADIATED EMISSIONS AT BANDEGE
-JBC MSMT (AVG) (US MOD, EXT ANT)

Ref 5 dBm

Atten 15 dB

Peak
Log
10
dB/

V1 V2
S3 FC
AA

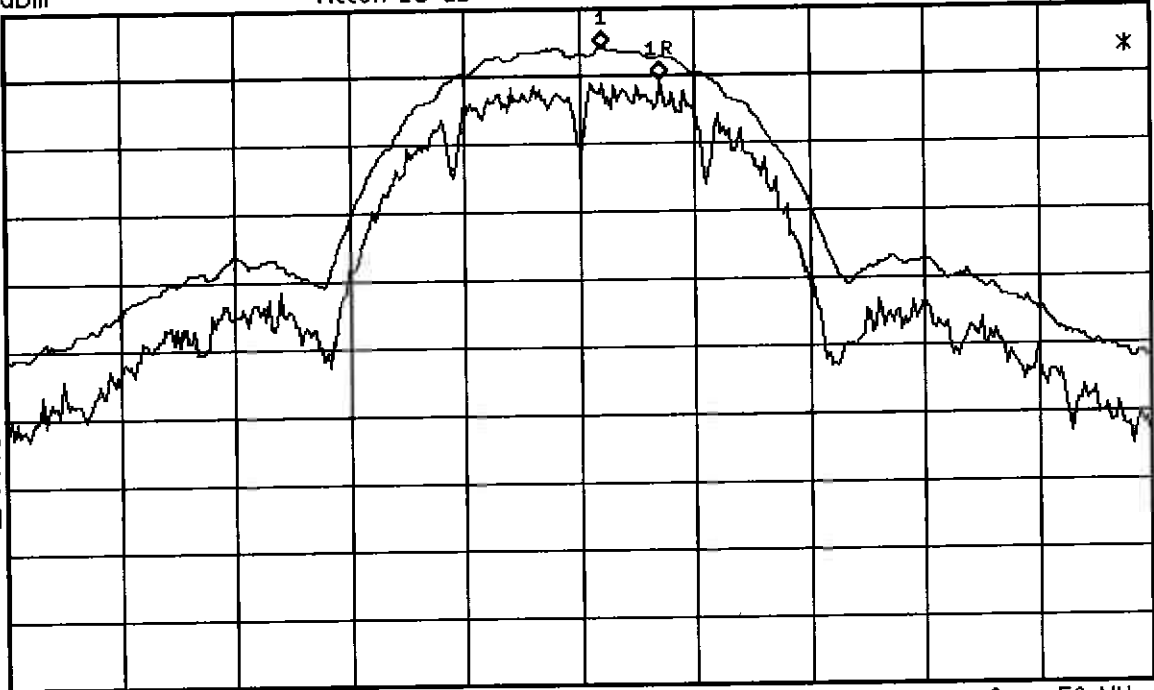

Center 2.462 GHz
*Res BW 100 kHz

VBW 100 kHz

Span 50 MHz
Sweep 6.442 ms (401 pts)

RADIATED EMISSIONS AT BAND EDGE
 Δ BW MSMT, RBW = 1 MHz & 100 kHz
(US MOD, EXT ANT)

Mkr1 Δ 25.0 MHz
49.53 dB

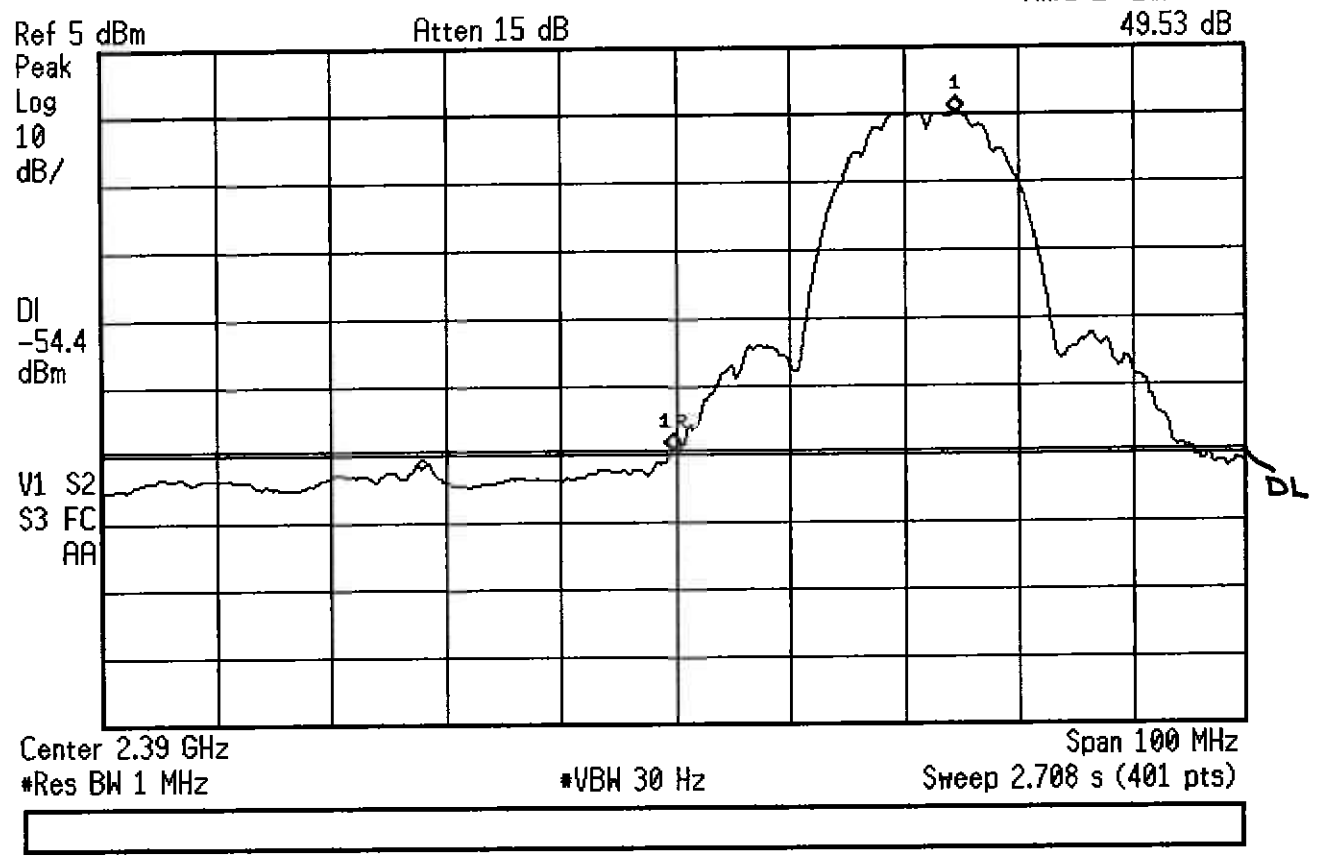

RADIATED EMISSIONS AT BandedGE
-dBC MSMT (AVG) (US MOD, EXT ANT)

- DISPLAY LINE IS THE LOWER OF
THE TWO LINES -

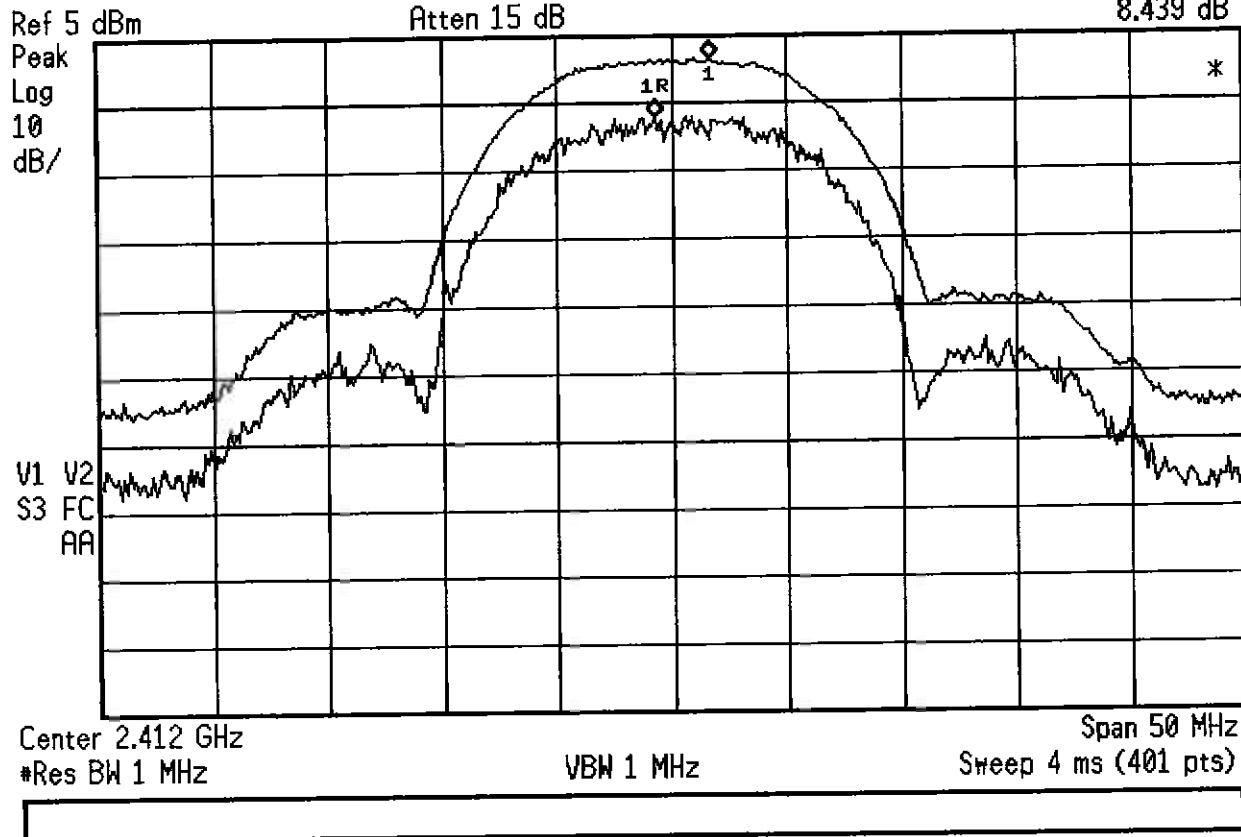

RADIATED EMISSIONS AT BANDEDGE
 Δ BW MSMT, RBW = 1 MHz \approx 100 kHz
(US MOD, EXT ANT)