



110 Nortech Parkway
San Jose, California, 95134

**FCC Part 15, Subpart E,
UNII (Part 15.401)
Certification Application**

**EMI Test Report
and
Technical Documentation
on
Airespace Virtual Access point.
Model: 1200**

FCC ID: QTZUSAP1200A

Prepared by:
David Waitt
202 Calvert Drive #217
Cupertino, Ca. 95014
david@waitt.us
(408) 832 7053

Table of Contents

<u>Section</u>	<u>Page</u>
General information-----	3
Detailed product information-----	4
Results summary-----	5
Test facilities-----	6
Test Equipment-----	7
Test methods-----	8
Test Results-----	9
Maximum power at RF Output-----	11
6dB Bandwidth-----	12
Power spectral density-----	16
Out of band emissions -----	20
Peak Excursion -----	35
Radiated emissions in restricted bands-----	39
AC Line Conducted Emissions-----	46

General Information

Unit(s) Under Test: Airespace Virtual Access point
Model: 1200
Product Description: IEEE 802.11A Access point

FCC ID: QTZUSAP1200A

Tested For: Airespace
110 Nortech Parkway
San Jose, CA. 95134

Tested At: Elliott Laboratories
684 West Maude Ave
Sunnyvale, CA 94086

Tested By: Chris Byleckie, Sr. Test Engineer, Elliott Laboratories
Juan Martinez, Sr. Test Engineer, Elliott Laboratories
David Waitt, (Independent Consultant)

Test Specifications: FCC CFR 47, Part Subpart E, (15 401 UNII)

Test Date: December 2002

Requested Certification: Part 15 Subpart E Certification

Company Background

Airespace (formerly Black Storm Networks), based in San Jose, California, is currently developing state of the art IEEE802.11 products.

Detailed Product Information / Operational Description

The Airespace radio is an IEEE 802.11 A access point (AP) intended to be professionally installed and configured in corporate and industrial environments.

The device utilizes a mini PCI module manufactured by an outside vendor. At the time of this certification the module had not received FCC approval as a module. For this reason, Airespace is pursuing its own certification.

The VAP utilizes integral antennas for the 802.11 A bands. The VAP includes two integral 5 GHz patch antennas pointing 180° from each other to create a somewhat omni directional 5GHz pattern. The effective gain of the 5 GHz antenna path (the antenna switch and the antenna itself) is 5.9dBi. The diagrams below outline the RF path from the output of the mini PCI module within the VAP to the integral antennas within the AP.

There is a provision for attaching external antennas to the VAP (which, when implemented will disable the integral antenna by means of the switch) however at this time, since external antennas are not included in this certification application, the ability to utilize an external antenna, and even switch the antenna selection switch to the other position will be disabled in the configuration software. The hardware was put in place to support the future use of external antennas once such use is authorized either by permissive change of new grant.

The VAP is powered either by an external 48V power supply or via power over Ethernet.

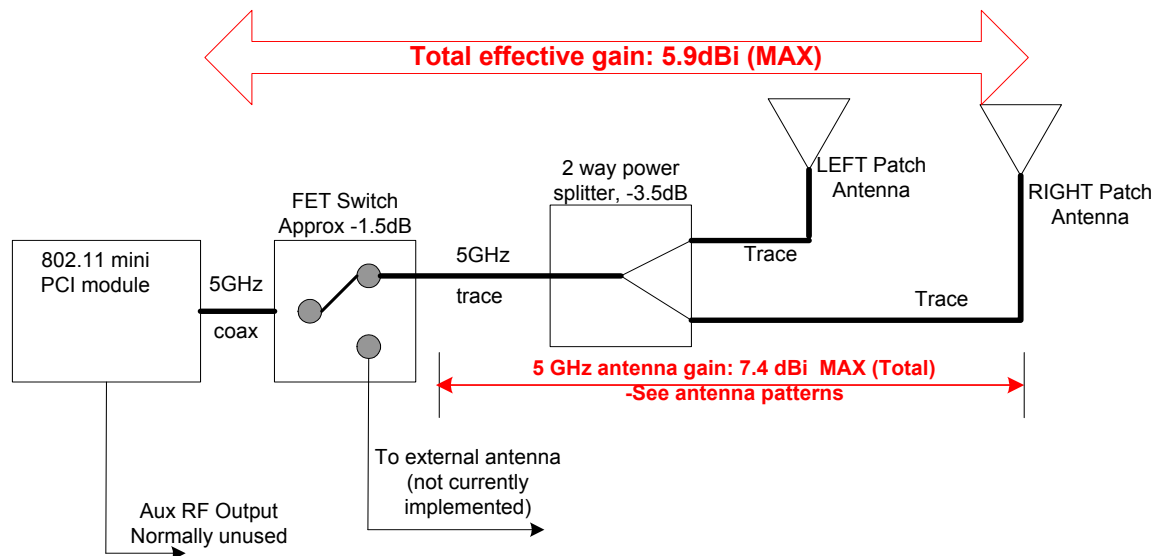

RF Path Schematics

Report Organization and Results Summary

This report presents the results of the tests that verify compliance with FCC Part 15.401. Though this product must comply with FCC Part 15.247 as well, only the 15.401 (UNII) results are contained in this report. The compliance information for Part 15.247 is contained in a separate report.

A brief results summary of all the in this report is below.

Part 15 Paragraph	Test	Results
15.407(a) (5)	Power Spectral Density	2.7dBm MAX
15.407(b) (1)	Out of Band Emissions (5.15 - 5.25)	-35.67dBm MAX
15.407(b) (1)	Out of Band Emissions (5.25 - 5.35)	-35.40dBm MAX
15.407(b) (1)	Out of Band Emissions (5.725 - 5.825)	-36.17dBm MAX
15.407(a)	26dB Bandwidth	27.08MHz
15.407(a) (1)	Transmit Power (5.15 - 5.35)	20dBm MAX
15.407(a) (3)	Transmit Power (5.275 - 5.825)	19.1 dBm MAX
15.407(a) (6)	Peak Excursion	3.6dB MAX
15.205	Radiated Emissions in Restricted bands	.5 dB in spec
CISPR 22	AC Line Conducted Emissions	15.25dB in Spec

Test Facilities

All of the certification tests were performed at:

Elliott Labs
684 West Maude Ave
Sunnyvale, CA 94086

General:

Final radiated test measurements were taken in Dec 2002 at the Elliott Laboratories Open Area Test Site #4.

The test site contains separate areas for radiated and conducted emissions testing. Pursuant to section 2.948 of the Rules, construction, calibration, and equipment data has been filed with the Commission.

The FCC recommends that ambient noise at the test site be at least 6 dB below the allowable limits. Ambient levels are below this requirement with the exception of predictable local TV, radio, and mobile communications traffic. The test site contains separate areas for radiated and conducted emissions testing. Considerable engineering effort has been expended to ensure that the facilities conform to all pertinent FCC requirements.

OATS:

The FCC has determined that radiation measurements made in a shielded enclosure are not suitable for determining levels of radiated emissions. Radiated emissions are performed in an open field environment. The test site is maintained free of conductive objects within the CISPR defined elliptical area incorporated in ANSI C63.4 Guidelines.

Antenna, Antenna Mast and Turntable

The Horn antennas that are used to measure radiated emissions above 1000MHz are mounted on a non-conductive antenna mast equipped with a motor drive to vary the antenna height.

ANSI C63.4 specifies that the test height above the ground plane shall be 80cm unless the equipment is intended to be floor mounted. During the radiated emissions tests the equipment is positioned on a motorized turntable in conformance with the ANSI requirement.

Equipment Lists

Instrument Calibration

All test equipment is regularly checked to ensure that performance is maintained in accordance with the manufacturer's specifications. All antennas are calibrated at regular intervals with respect to tuned half-wave dipoles. An exhibit of this report contains the list of test equipment used and calibration information.

The following test equipment was used to perform the testing

Elliott Test Equipment

<u>Item</u>	<u>Desc.</u>	<u>Manufacturer</u>	<u>Model</u>	<u>S/N(Elliott #)</u>	<u>Cal due date</u>
1.	Spectrum Analyzer	Agilent	8564E	Elliott 1393	21 Feb 03
2.	3.5 GHz HPF	HP	NA	84300-80038	1 Mar 03
3.	Pre Amp	Miteq	ASF 44	805817	7 Jan 03
4.	Antenna	EMCO	3116	9711-5359	2 Mar 03
5.	Antenna	EMCO	3115	487	22 Apr 03
6.	Spectrum Analyzer 9kHz - 40 GHz	HP	8564E (84125C)	1393	21 Feb 03
7.	Peak Power Meter	Rhode & Schwartz	NRYS	835360/070	6 Sept 03
8.	Power Head	Rhode & Swartz		836019/016	6 Sep 03

Additional Test Equipment

<u>Item</u>	<u>Desc.</u>	<u>Manufacturer</u>	<u>Model</u>	<u>S/N</u>	<u>Cal due date</u>
1.	Peak Power meter	Agilent	4416A	GB40320299	7 July 03
2.	Power Head	Agilent	E9327A	US40440899	16 Oct 03
3.	Spectrum Analyzer	Agilent	E4404B	US40521093	3 Sep 03

Test Methods

Many of the tests are performed at a low, middle and high channel of the applicable band. The typical frequencies used for the test for each band are listed below. Recall that this report details the results for the UNII bands only. Where applicable, the test procedures outlined in FCC Public notice DA 02-2138 (30 Aug 2002) were used.

UNII 802.11 A	
5.15 – 5.25 GHz	
5.25 – 5.35 GHz	
Channel	Freq(MHz)
Low	5180
Mid	5260
High	5320

UNII / 802.11 A	
5.725 5.825 GHz	
Channel	Freq(MHz)
Low	5745
Mid	5765
High	5805

In order to comply with the “radiated emissions in restricted bands” requirements the transmit power had to be lowered on some of the channels at the edges of the band. The maximum power setting that yielded compliance with the radiated emissions requirements will be programmed into the configuration firmware of the access point ensuring that maximum possible power setting will be correct for each channel. Given that the access point will normally be operated at these power settings, they were also used during the “bench top” conducted RF tests (spectral density, bandwidth etc).

The tests listed below are performed using the basic test setup shown below. In several cases, the EUT was running special diagnostic firmware to allow it to transmit random data on a particular channel indefinitely.

Part 15	Test
15.407(a)(5)	Power Spectral Density
15.407(b)(1)	Out of Band Emissions (5.15 - 5.25)
15.407(b)(1)	Out of Band Emissions (5.25 - 5.35)
15.407(b)(1)	Out of Band Emissions (5.725 - 5.825)
15.407(a)	26dB Bandwidth
15.407(a)(1)	Transmit Power (5.15 - 5.25)
15.407(a)(2)	Transmit Power (5.25 - 5.35)
15.407(a)(3)	Transmit Power (5.275 - 5.825)
15.407(a)(6)	Peak Excursion

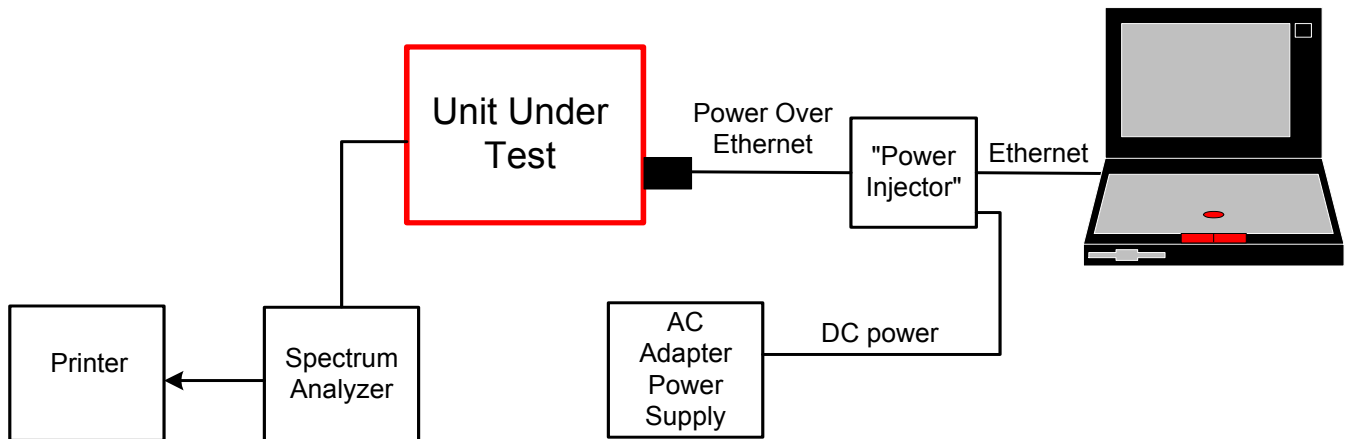

Basic Conducted RF Bench Test Setup

Unless otherwise noted, the support equipment for the bench tests is listed below.

Support Equipment				
Description	Model number	FCC ID or SN	Manufacturer	Power Cable
Laptop	Armada E 500	P31000T4X20DC12N2	Compaq	Laptop PS
Test Software	Atheros Radio Test		Atheros	
48VDC AC adapter	Generic		Generic	Standard Twin lead DC wire

Test Results

Detailed test procedures and test results are contained in the following sections. In cases where the test setup differs from the Conducted RF test setup shown earlier, the test setup is also presented.

Test Conditions			
Temperature	24 C	Humidity:	52%
ATM pressure	1017 mBar	Grounding:	None
Tested By	David Waitt	Date of Test:	Dec 02 / Jan 03
Test Reference	Refer to individual test results		
Tested Range	Test Dependent		
Test Voltage	48 VDC to the VAP		
Modifications	No modifications were made to the unit during the tests		

802.11 A Maximum RF Power Output at Antenna Terminals

Specifications:

FCC Specification: Paragraph(s): 15.401(a)(1), 15.401(a)(2), 15.401(a)(3)

Procedure:

The test was conducted by connecting the secondary output of the 802.11 module directly to a peak power meter. This measured power is therefore the same level that will be present at the input of the FET antenna switch under normal operation.

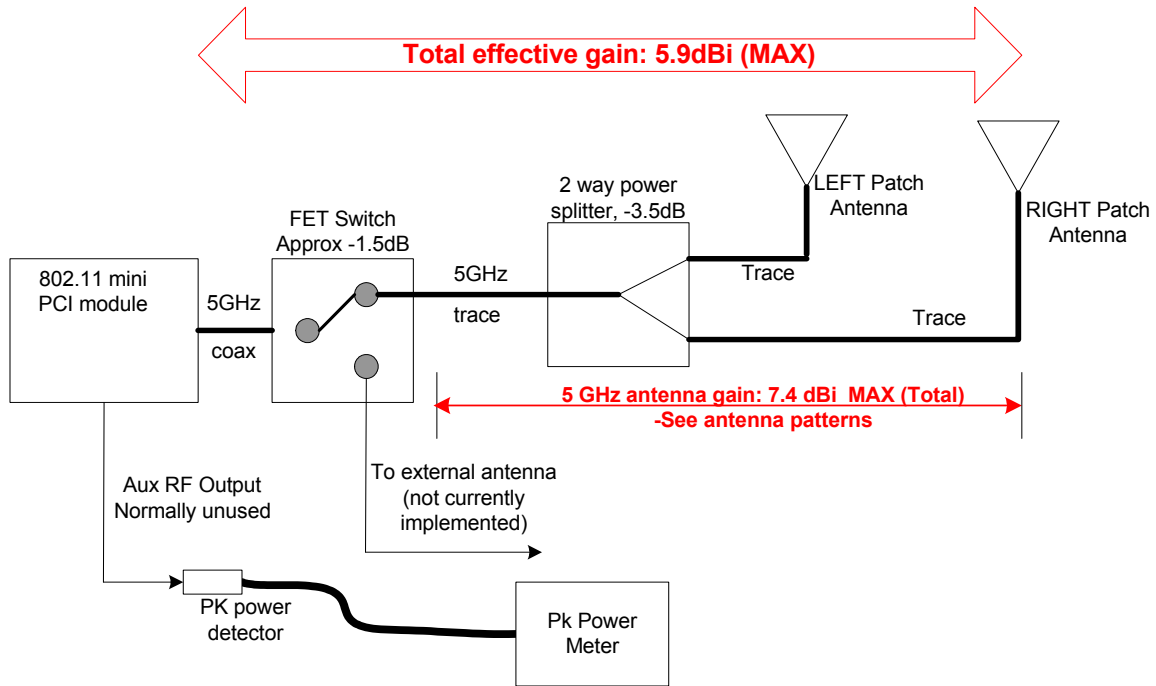

The unit was tuned to the test channels and configured to transmit random data packets. The transmit power was measured directly off of the meter.

Because the unit will be operated at different power levels depending on the channel / band being used, the RF power out was measured at the appropriate power setting for the given test channel / band. The settings that were used during the test are the settings that will be entered into the firmware of the VAP. These firmware configuration limits will ensure that the power levels are not exceeded.

RF Transmit Power Result:

The following power levels were measured on low and high channels for each sub-band.

Pout settings Vs. Channel	802.11a/b Channel	Frequency (MHz)	Specification (dBm) into 6 dBi	AVG Measured Pout (dBm)	AVG Measured Pout (mWatts)
5 GHz UNII upper	149	5745.00	30	17.8	60.25
	153	5765.00	30	18.2	66.06
	161	5805.00	30	16.2	41.68
5 GHz UNII lower	36	5180.00	17	13.2	20.89
	48	5240.00	17	14.1	25.70
	52	5260.00	24	18.0	63.09
	64	5320.00	24	9.8	9.54

5 GHz 26 dB bandwidth

Specification

FCC Specification: Paragraph 15.407(a)

The Airespace VAP access point operates on the standard IEEE 802.11 A channels. The 26dB bandwidth was measured on the low middle and high channel of the 5 GHz UNII bands using the conducted RF test setup. The spectrum analyzer was configured for MAX HOLD and the trace allowed to stabilize. A peak search was performed and the then Delta-Marker used to locate the point -26dB below the peak.

Once this was complete, the point was used as a reference and another delta measurement was performed to the and an attempt made to make the two markers "level". The delta frequency between the two markers was measured as the 26 dB BW of the signal. The bandwidth test was performed at the power settings that will be used in the final system.

Results:

Channel	Frequency (MHz)	Resolution Bandwidth	26 dB Signal Bandwidth (MHz)	20 dB Signal Bandwidth (MHz)	Graph reference #
161	5805	300 kHz	31.58	22.42	refer to plots below
153	5765	300 kHz	37.75	27.08	refer to plots below
149	5745	300 kHz	27.83	20.17	refer to plots below
64	5320	300 kHz	27.08	21.00	refer to plots below
52	5260	300 kHz	36.75	26.17	refer to plots below
36	5180	300 kHz	28.42	21.42	refer to plots below

26dB BW Plots

Channel 161 (5805)

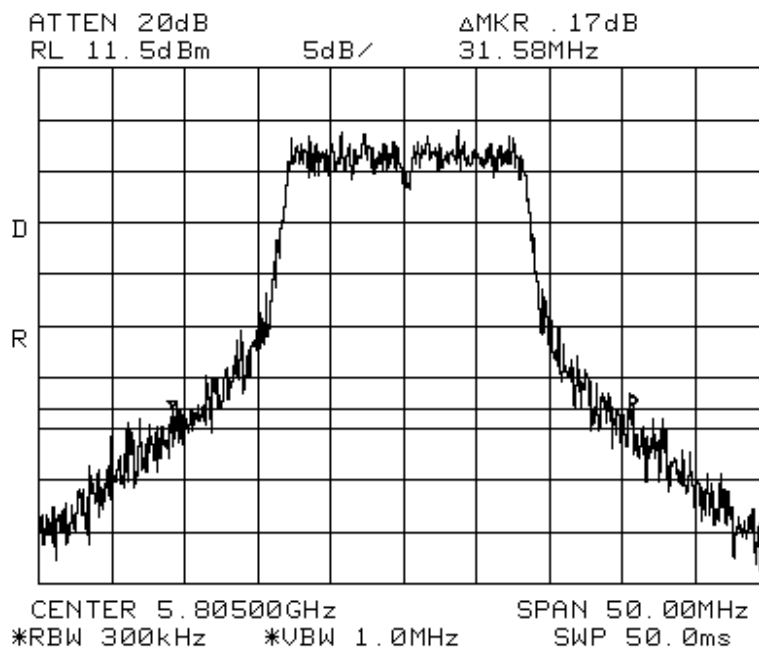

Channel 64 (5320)

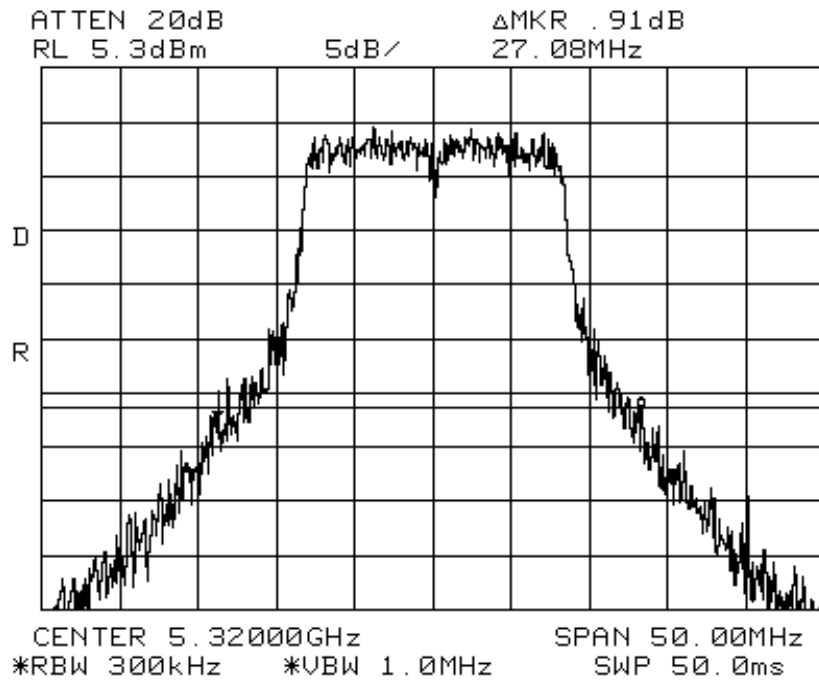

Channel 52 (5260)

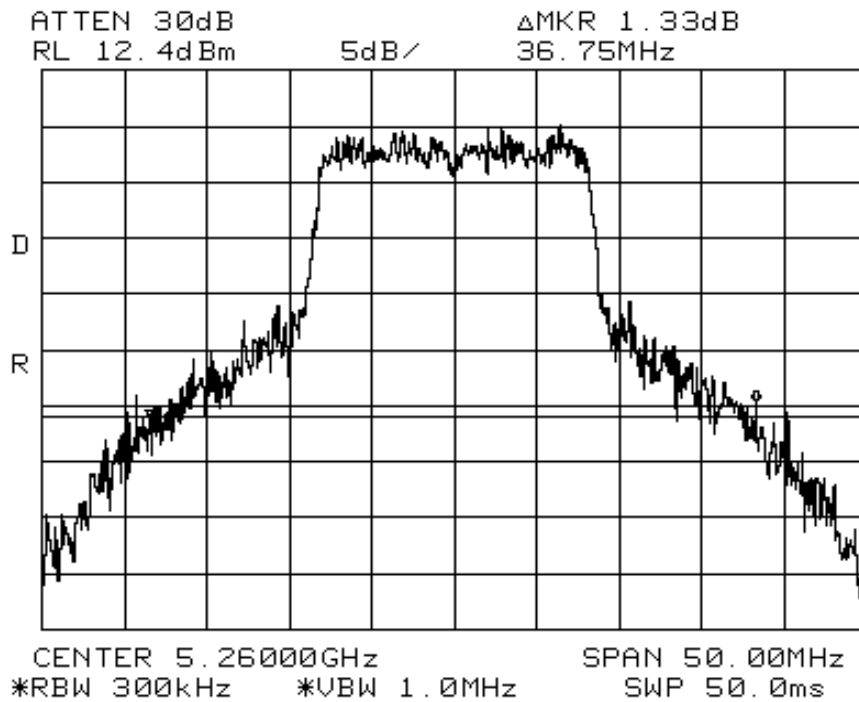

Channel 36 (5180)

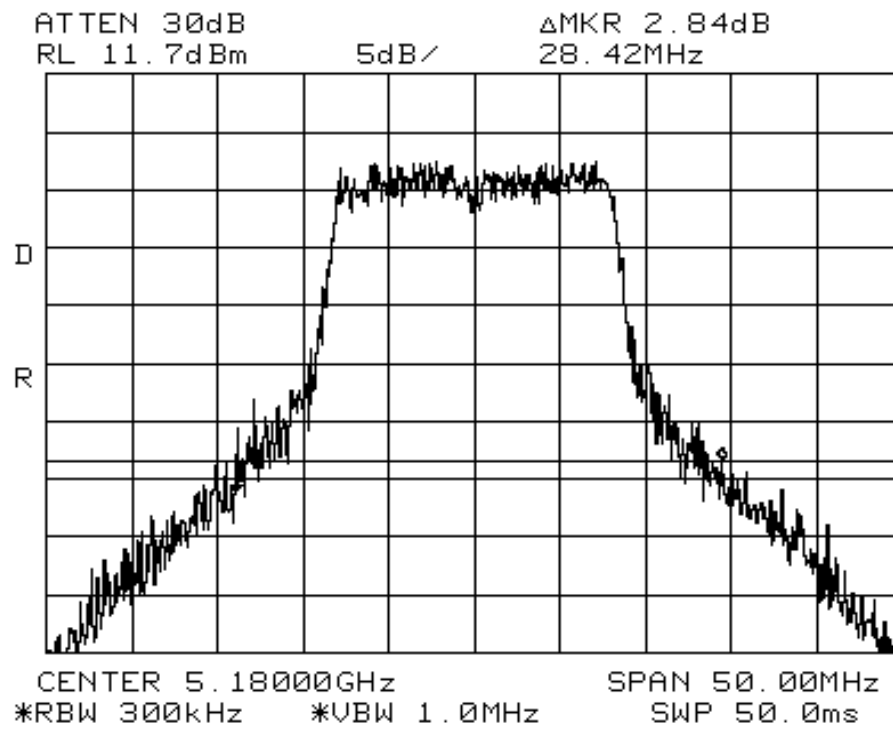

5 GHz Power Spectral Density

Specification

FCC Specification: Paragraph 15.407(a)(5)

Procedure:

The test setup was configured as shown in the conducted test setup. The UUT was configured to continuously transmit random data packets. Initially the bandwidth of the entire channel was examined. Using MAX HOLD and peak search, the frequency with the maximum power was determined.

The above measurements were made using RBW = 1MHz, VBW = 1MHz, video averaging on. The peak PSD of 11.7 dBm did not exceed the maximum permitted average PSD of 10dBm (5.15 to 5.25 GHz band) or 11dBm (5.25-5.35GHz band), (Peak PSD limits have an additional 6 dB) so no restriction are placed on the output power or average PSD with respect to RSS 210.

The power spectral density was measured at the designated test channels with the appropriate power setting for the given test channel.

Results:

Frequency (MHz)	FCC P.S.D. (dBm/MHz)	Canada P.S.D (dBm/MHz)	FCC Limit (dBm)	Graph Reference
5805	0.3	9.5	17.0	refer to plots below
5765	2.7	11.7	17.0	refer to plots below
5745	2.4	12.0	17.0	refer to plots below
5320	-4.3	3.7	11.0	refer to plots below
5260	2.5	11.6	11.0	refer to plots below
5180	-0.38	8.9	4.0	refer to plots below

Power Spectral Density Plots

Channel 161
(5805)

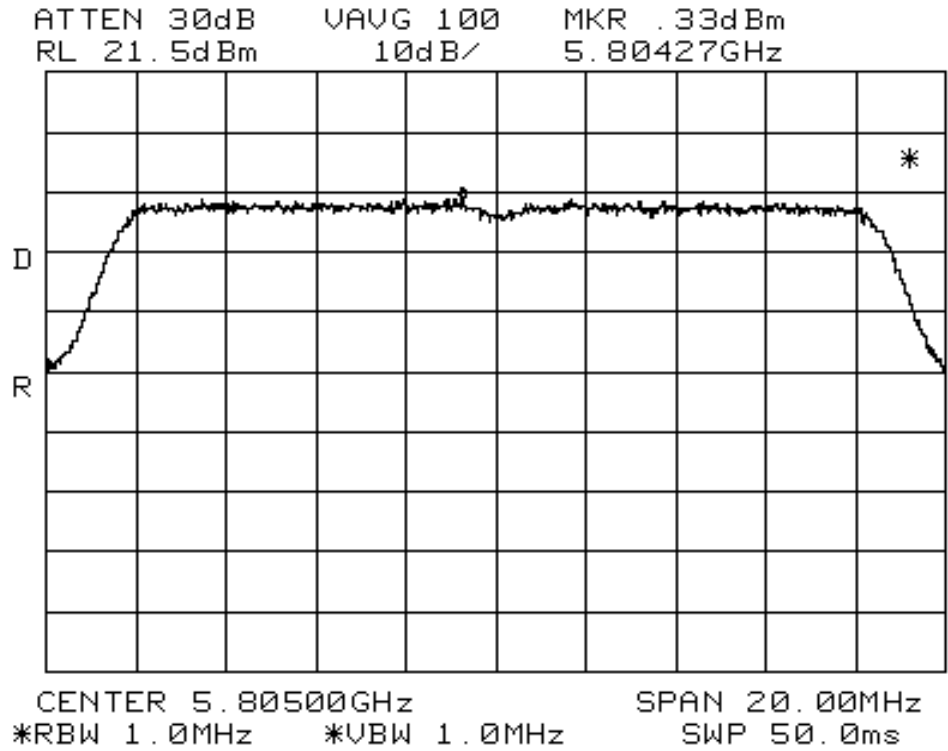

Channel 153
(5765)

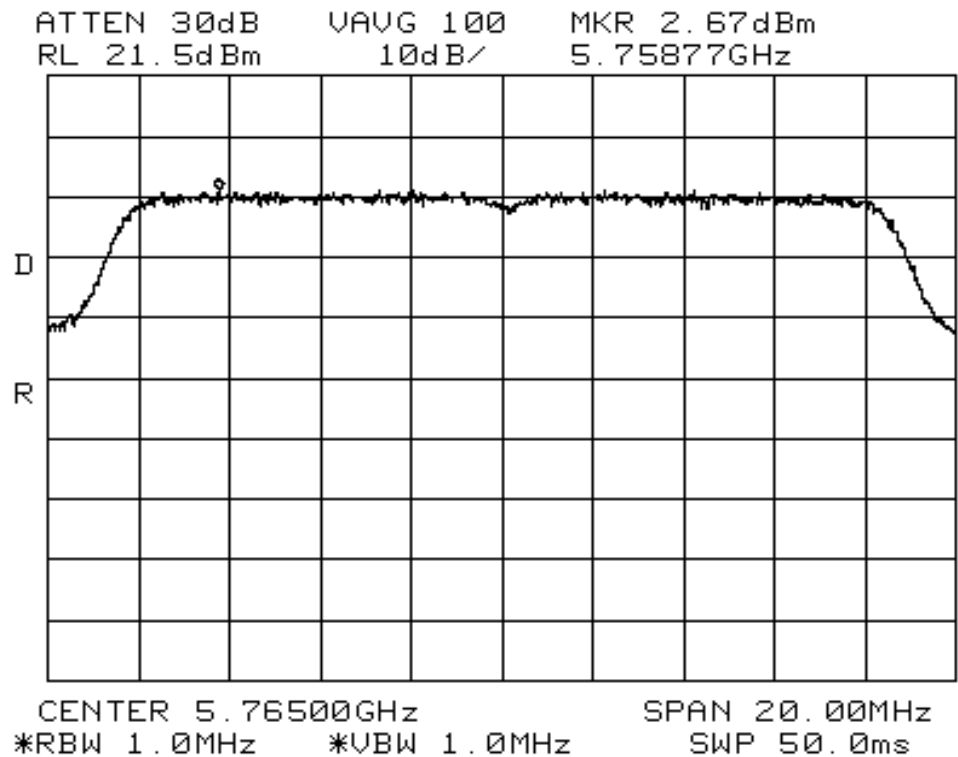

Channel 149 (5745)

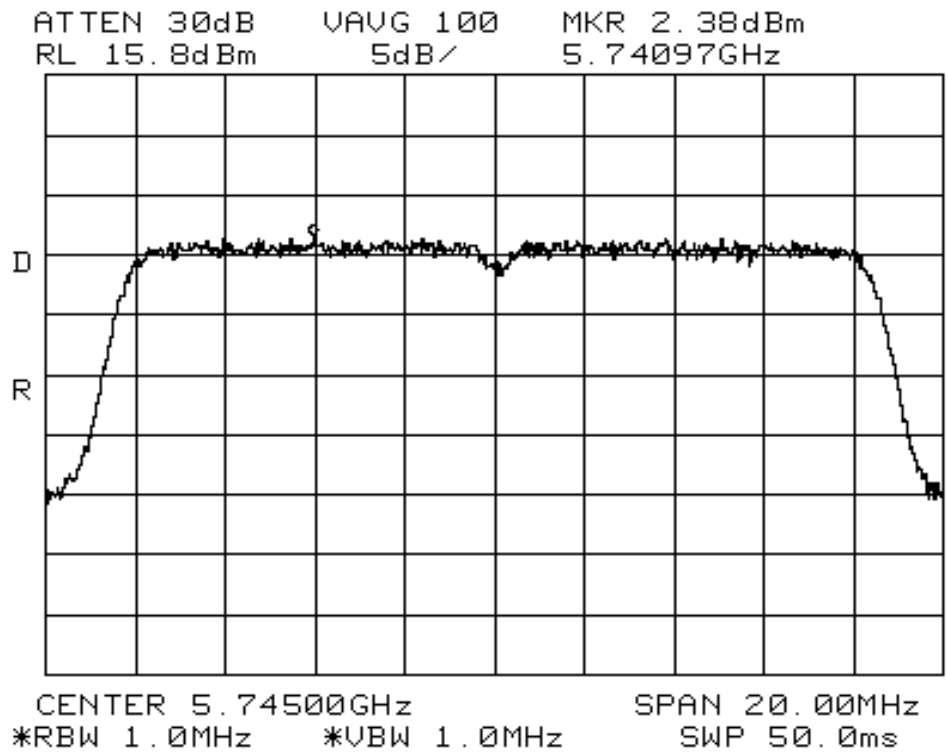

Channel 64 (5320)

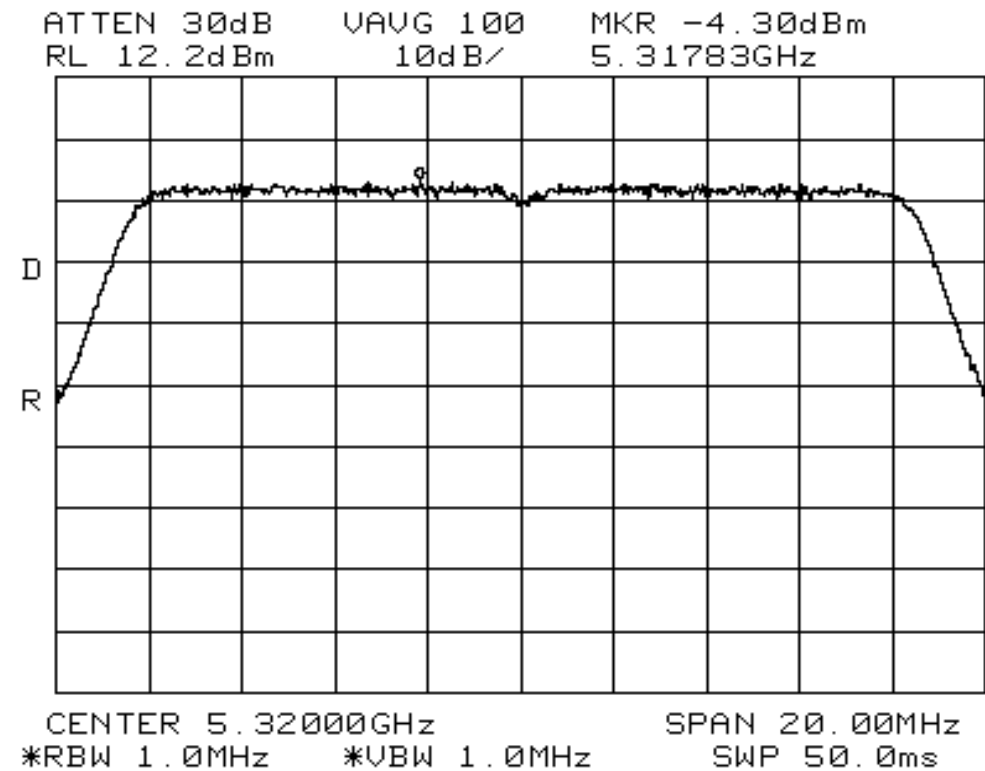

Channel 52 (5260)

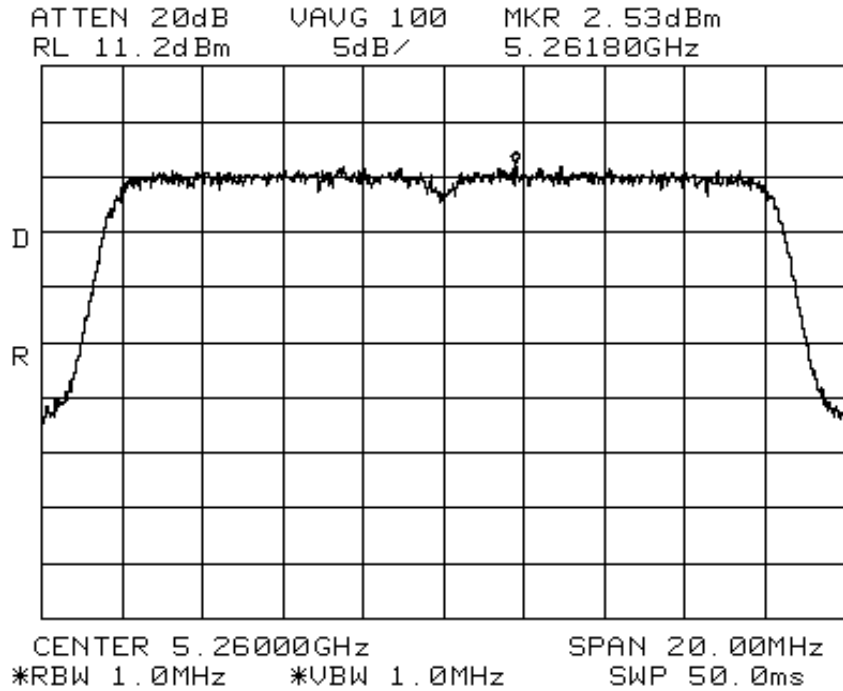

Channel 36 (5180)

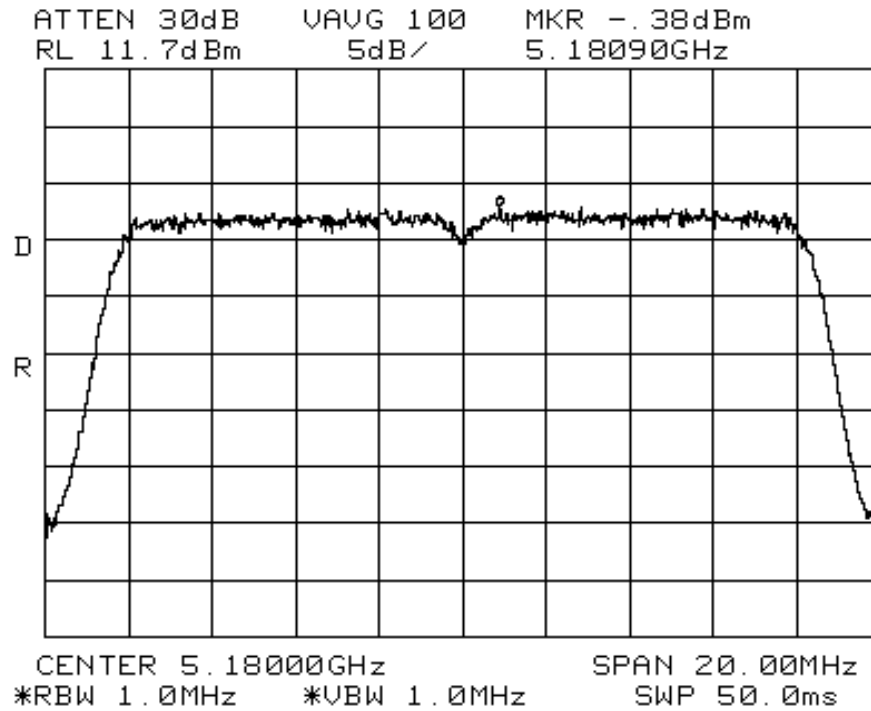

5 GHz Out of band Spurious Emissions

Specification

FCC Specifications: Paragraphs 15.407(b)(1), 15.407(b)(2), 15.407(b)(3),

Procedure:

The test was configured as shown in the Conducted RF test setup. The UUT was configured to transmit random data packets. The band from 1 GHz to 40GHz was examined spurious emissions. This test was conducted on the low middle and high

Results:

Lower UNII band(s) emissions summary.

The specification references -27dBm (or -17dBm) present at the output of the product. Since this data was measured at an RF conducted port, the measured level would not include any antenna gain. This, the -27dBm spec out of the unit referenced back to the output of the module where this data was measured is equal to $-27\text{dBm} - 5.9\text{dBi}$ of antenna gain = -32.9dBm out of the RF module. This assumes a worst-case scenario that the antenna has 5.9 dBi of gain at all of these frequencies, which, of course, is not the case. The same procedure is used for the upper UNII band summary

Channel	Frequency (MHz)	Frequency Range	Limit $-27\text{dBm}-5.9\text{dBi}=-32.9\text{dBm}$	Highest Spurious Signal (dBm)	Delta
36	5180	30 - 1000 MHz	-32.9	-55.83	22.93
		1 to 5.15 GHz	-32.9	-35.67	2.77
		5.25 to 10 GHz	-32.9	-44.17	11.27
		10 GHz to 20 GHz	-32.9	-45.67	12.77
		20 GHz to 40 GHz	-32.9	-43.83	10.93
52	5260	30 - 1000 MHz	-32.9	-56.33	23.43
		1 to 5.15 GHz	-32.9	-54.33	21.43
		5.35 to 10 GHz	-32.9	-45.83	12.93
		10 GHz to 20 GHz	-32.9	-34.50	1.60
		20 GHz to 40 GHz	-32.9	-44.00	11.10
64	5320	30 - 1000 MHz	-32.9	59.00	26.10
		1 to 5.15 GHz	-32.9	-52.17	19.27
		5.35 to 10 GHz	-32.9	-36.17	3.27
		10 GHz to 20 GHz	-32.9	-41.67	8.77
		20 GHz to 40 GHz	-32.9	-44.00	11.10

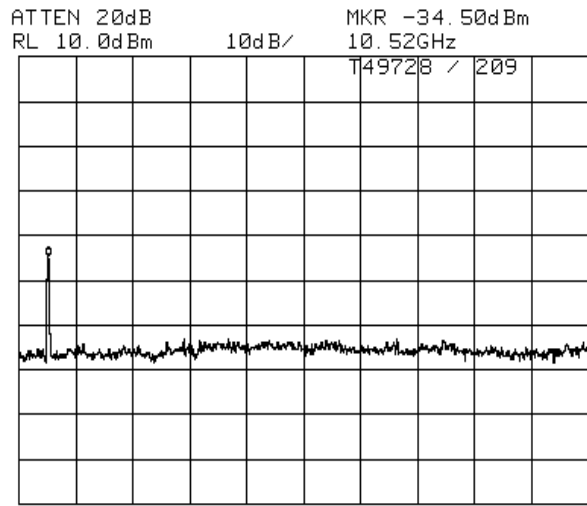

START 10.00GHz STOP 20.00GHz
RBW 1.0MHz VBW 1.0MHz SWP 200ms

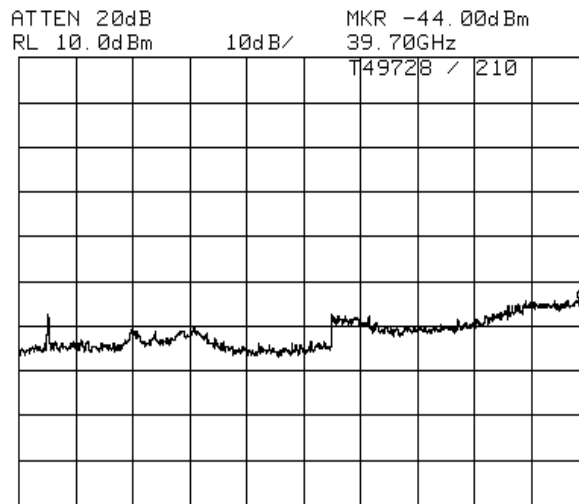

START 20.00GHz STOP 40.00GHz
RBW 1.0MHz VBW 1.0MHz SWP 400ms

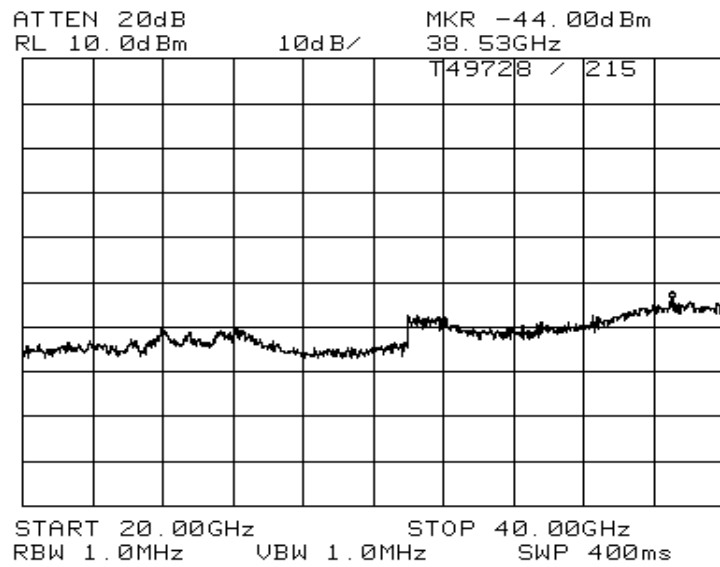
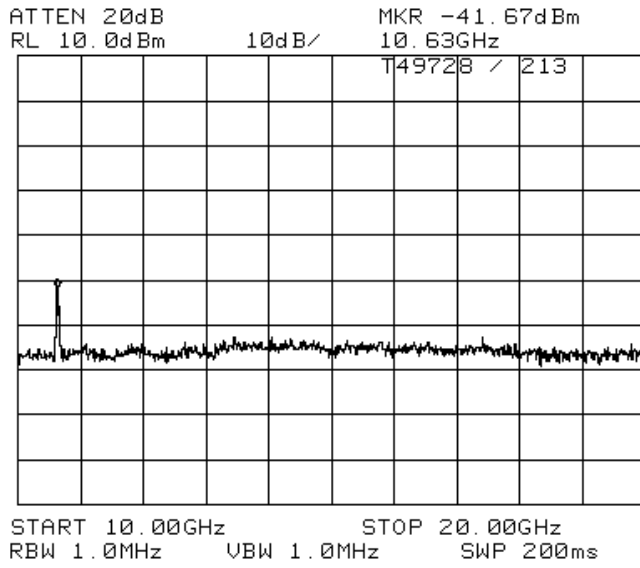

Upper UNII band(s) emissions summary

Channel	Frequency (MHz)	Frequency Range	Limit -27dBm-5.9dBi= -32.9dBm	Highest Spurious Signal (dBm)	Delta dB
149	5745	30 - 1000 MHz	-32.9	-56.17	23.27
		1 to 5.7 GHz	-32.9	-40.17	7.27
		5.7 to 5.725 GHz	See Bandedge data		
		5.825 to 10 GHz	-32.9	-50.83	17.93
		10 GHz to 20 GHz	-32.9	-51.17	18.27
		20 GHz to 40 GHz	-32.9	-42.50	9.6
153	5765	30 - 1000 MHz	-32.9	-56.00	23.1
		1 to 5.725 GHz	-32.9	-40.17	7.27
		5.825 to 10 GHz	-32.9	-47.00	14.1
		10 GHz to 20 GHz	-32.9	-51.50	18.6
		20 GHz to 40 GHz	-32.9	-43.00	10.1
161	5805	30 - 1000 MHz	-32.9	-58.83	25.93
		1 to 5.725 GHz	-32.9	-49.83	16.93
		5.825 to 5.85 GHz	See Bandedge data		
		5.85 to 10 GHz	-32.9	-43.67	10.77
		10 GHz to 20 GHz	-32.9	-49.33	16.43
		20 GHz to 40 GHz	-32.9	-54.67	21.77

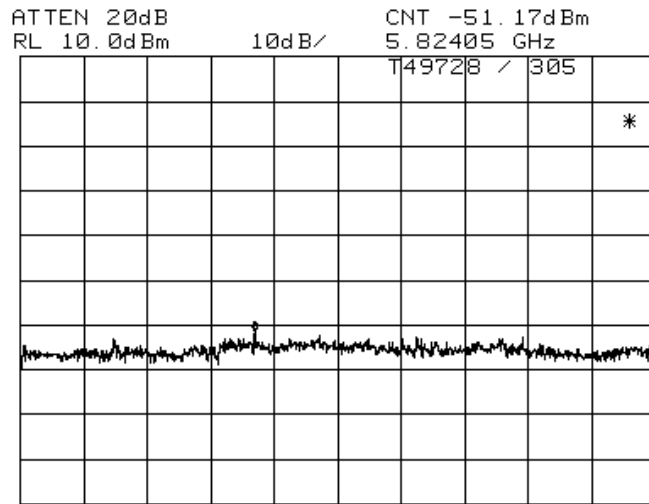

START 10.00GHz STOP 20.00GHz
RBW 1.0MHz VBW 1.0MHz SWP 200ms

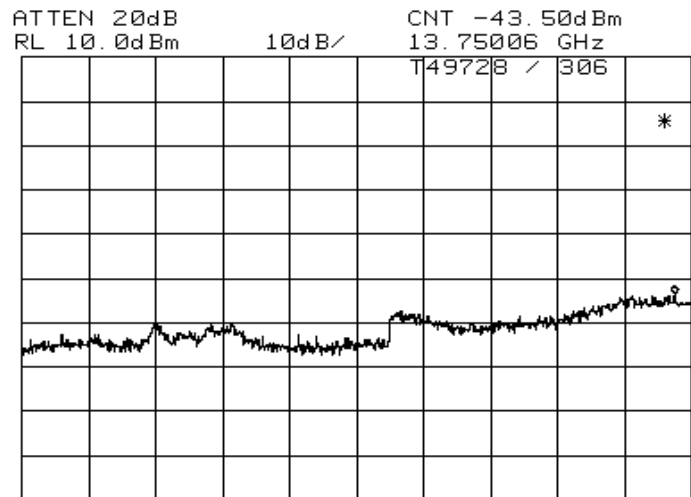

START 20.00GHz STOP 40.00GHz
RBW 1.0MHz VBW 1.0MHz SWP 400ms

ATTEN 20dB CNT -51.50dBm
RL 10.0dBm 10dB/ 5.82500 GHz

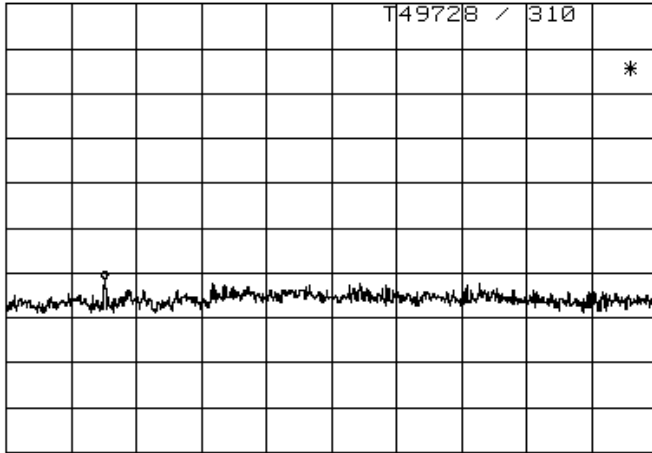

START 10.00GHz STOP 20.00GHz
RBW 1.0MHz VBW 1.0MHz SWP 200ms

ATTEN 20dB CNT -43.00dBm
RL 10.0dBm 10dB/ 23.49884 GHz

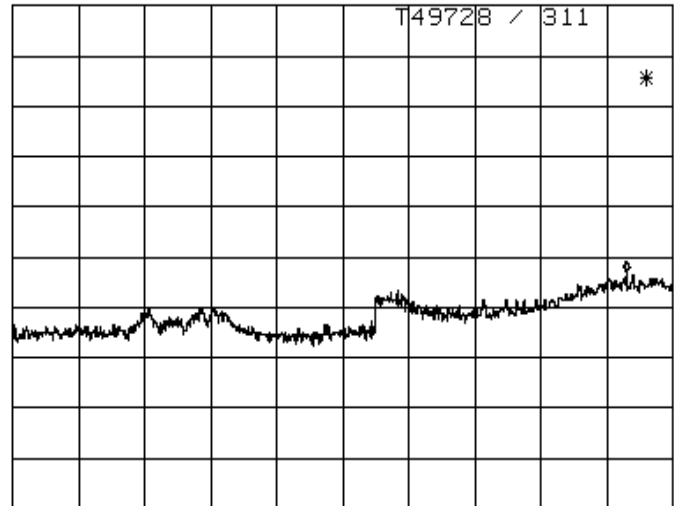

START 20.00GHz STOP 40.00GHz
RBW 1.0MHz VBW 1.0MHz SWP 400ms

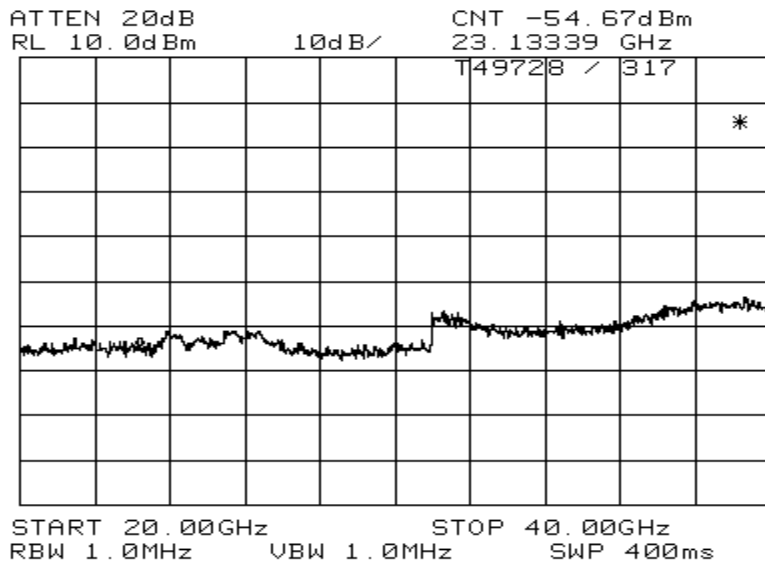
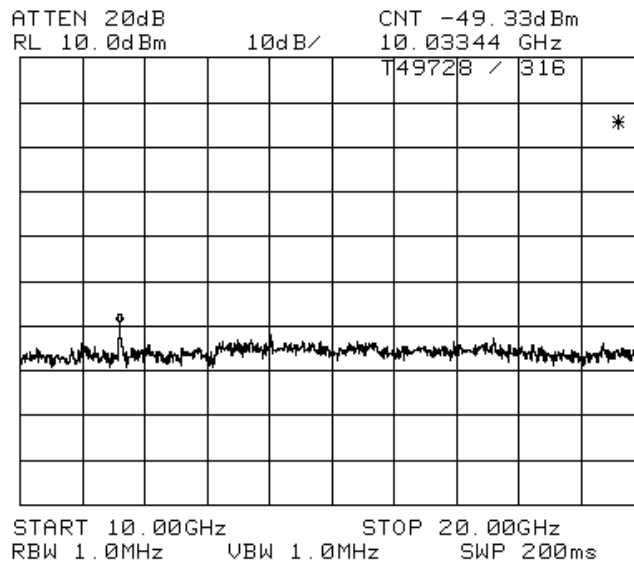
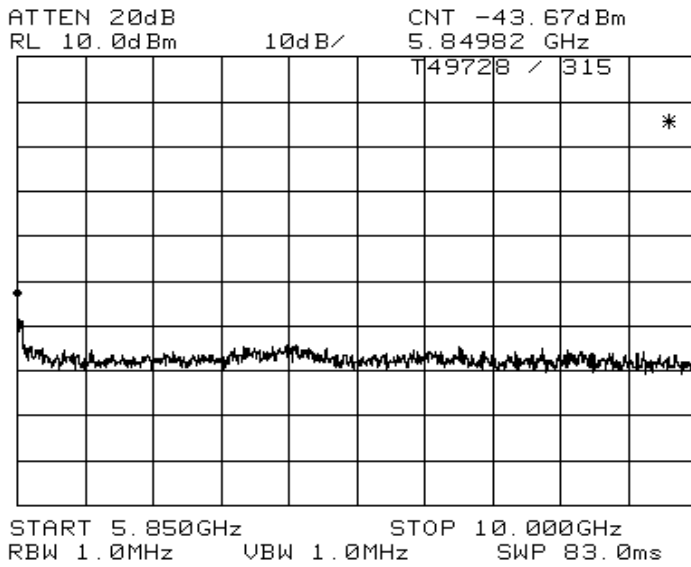

5.725 – 5.825 GHz bandedge

Specification

FCC Specifications: Paragraphs 15.407(b)(3)

Procedure:

The test was configured as shown in the Conducted RF test setup. The UUT was configured to transmit random data packets. 10 MHz immediately above and below the 5.735 – 5.825 GHz band was examined spurious emissions. This test was conducted on the low and high channels with the UUT configured to the appropriate power setting indicated in the “power setting table” depending on the test channel.

Results:

Upper UNII band bandedge emissions summary

Channel	Frequency (MHz)	Frequency Range	Limit -17dBm-5.9dBi= -22.9dBm	Level at the band edge (dBm)	Delta dB Below Limit
149	5745	5.715 - 5.725 GHz	-22.9	-28.38	5.48
161	5805	5.825 - 5.835 GHz	-22.9	-36.10	13.20

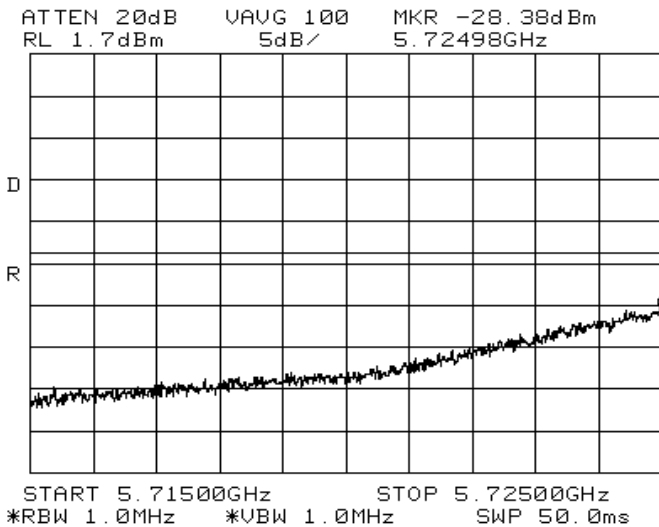

Plot of the 5,725 GHz lower band edge showing the peak @ -28.38dBm

Plot of the 5,825 GHz upper band edge showing the peak @ -36.17dBm

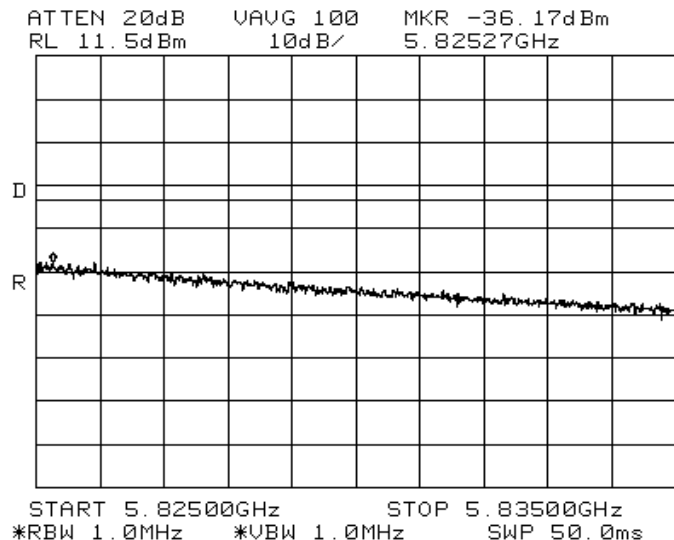

Peak Excursion

Specification

FCC Specifications: Paragraphs 15.407(a)(5)

Procedure:

The test equipment was configured as shown in the RF Conducted bench setup. The analyzer was set to an appropriate span to view the entire emission bandwidth. There were two traces made in order to determine the peak excursion. The following settings were used for the two traces. The delta between the two traces must be less than 13 dB

Trace 1: RBW = 1 MHz, VBW = 3 MHz with peak detector and max-hold settings.

Trace 2: RBW = 1 MHz. Set VBW = 300 kHz, set to Max Hold and allowed to settle for 60 seconds.

Peak Excursion = 3.03 dB. Frequency 5805 MHz

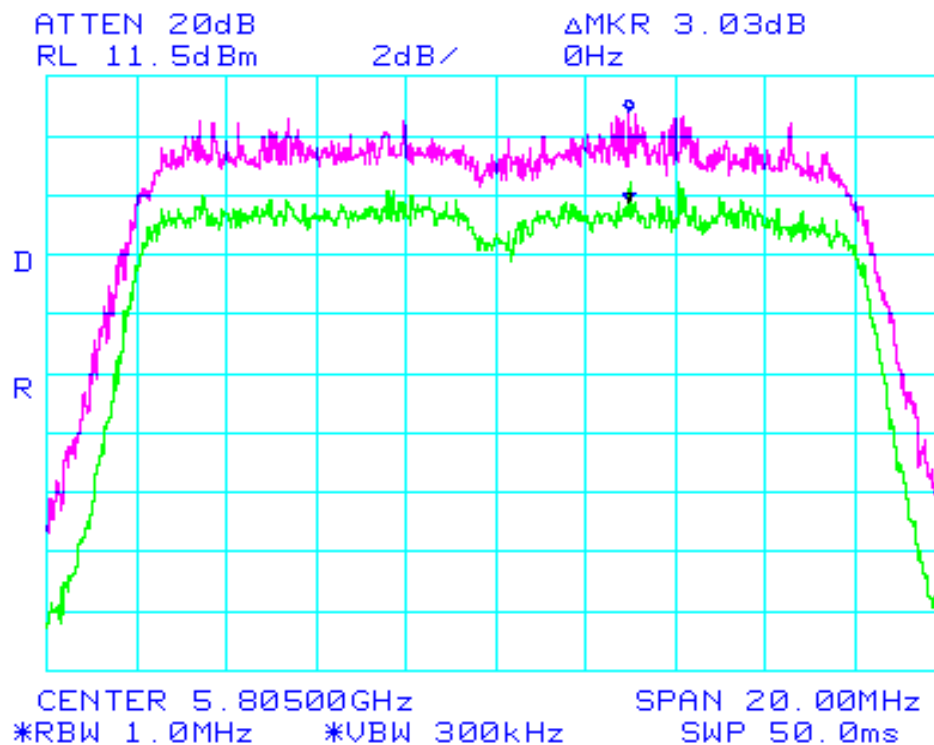

Peak Excursion = 3.03 dB. Frequency 5765 MHz

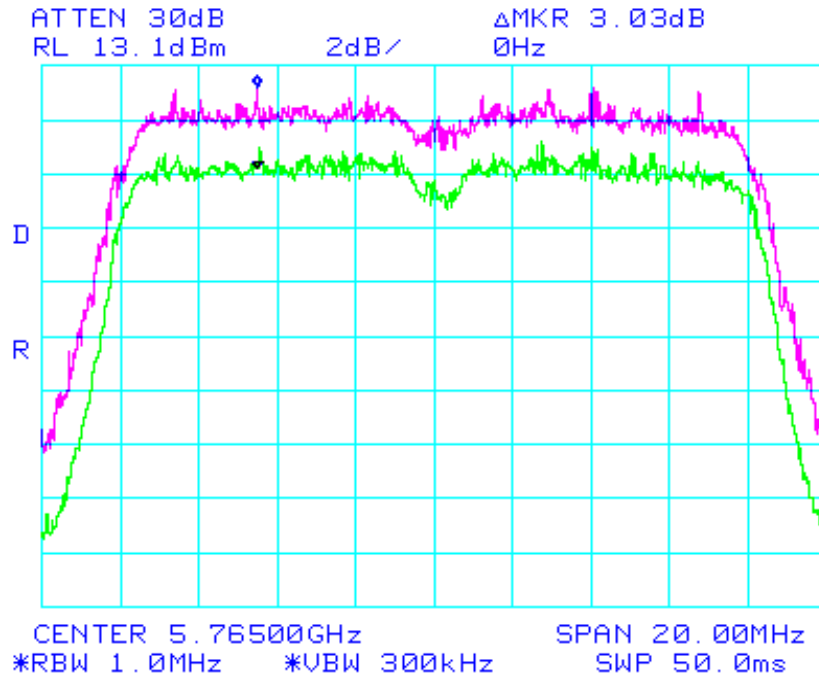

Peak Excursion = 3.60 dB. Frequency 5745 MHz

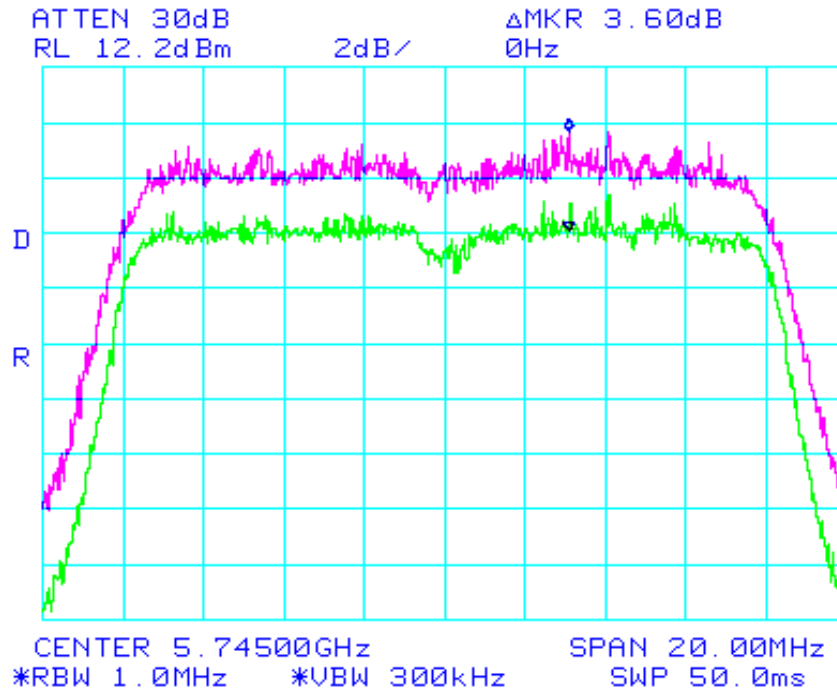

Peak Excursion = 2.87 dB. Frequency 5320 MHz

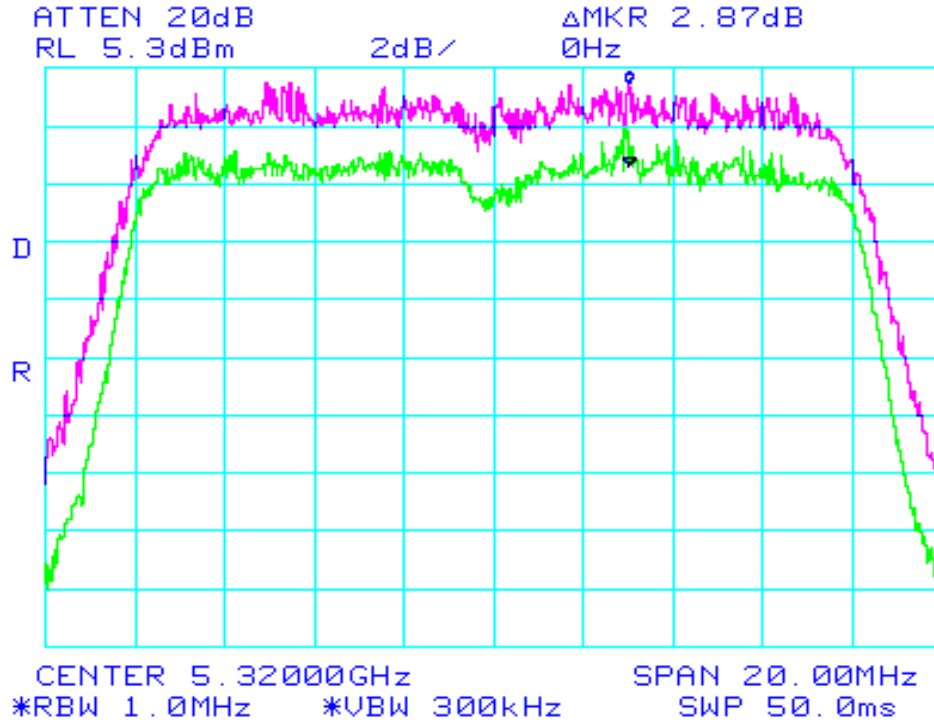

Peak Excursion = 2.97 dB. Frequency 5260 MHz

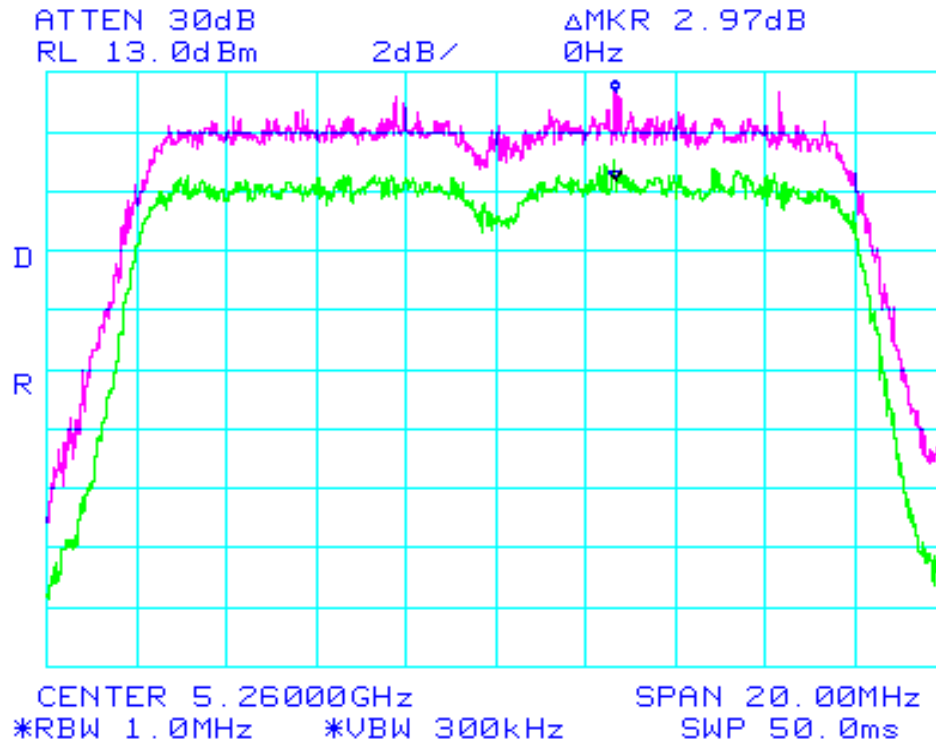

Peak Excursion = 3.40 dB. Frequency 5180 MHz

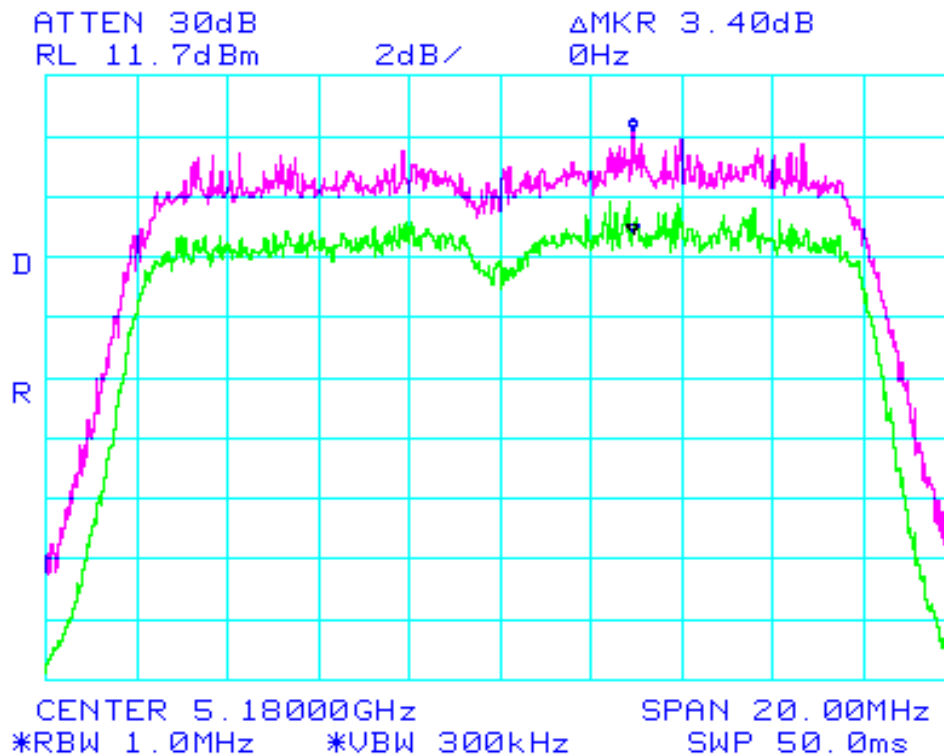

5 GHz Radiated Emissions in Restricted bands

Specification:

FCC Specification:

Paragraph 15.407(b)(6)

Procedure:

This test was conducted on a 3-meter open-air test site at Elliott Laboratories. The unit was placed on a rotating wooden table 80cm above the ground plane. A Horn antenna(s) were secured to a mast 3 meters away. The unit was tested at each of the Low, Mid and High channels. The UUT was running in the diagnostic mode and set to transmit random data. The transmit power was set to the settings outlined in the power setting table. The test equipment was configured as shown below.

The harmonics of the fundamental that fell within restricted bands were measured (See table 1 below). A high pass filter prior to the pre-amplifier was required to prevent the signal level of the fundamental frequency from overloading the front end of the spectrum analyzer and creating harmonics within the analyzer.

The EUT was rotated 360 degrees and the height of the antenna adjusted from 1 to 4 meters above the ground plane to determine the maximum level of the emission. The level of the harmonic emission was measured in two modes, "Peak" and "Average".

The spectrum analyzer reading was entered into a spreadsheet where correction factors (antenna factor, cable loss, pre-amplifier gain, HPF loss...) were then applied by Elliott Lab's Software to obtain a final corrected measurement.

This procedure was repeated for the low mid and high channels across the 5 GHz bands. The table below indicates the harmonics that fall within restricted bands.

Fund	Harmonic								
	2	3	4	5	6	7	8	9	10
5745	11490	17235	22980	28725	34470	40215	45960	51705	57450
5765	11530	17295	23060	28825	34590	40355	46120	51885	57650
5805	11610	17415	23220	29025	34830	40635	46440	52245	58050

15.407(b)(6) Harmonic test table

*NOTE: **RED** indicates a harmonic that falls within a restricted band, the harmonics in **gray** are NOT in restricted bands.*

Test Setup

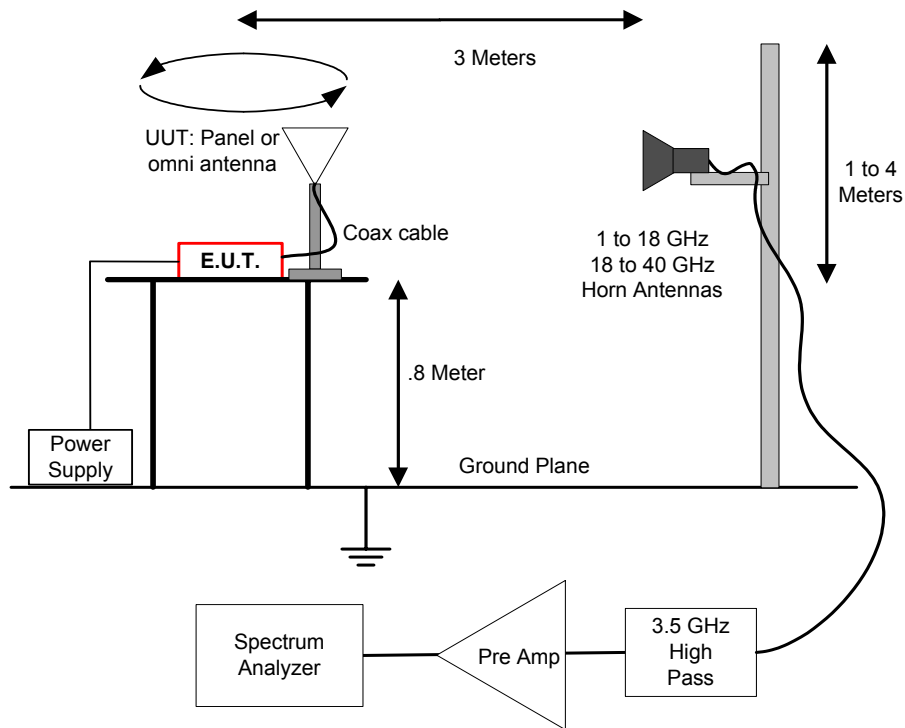

Radiated Emissions in Restricted Bands Test Setup

Support Equipment

Description	Model number	FCC ID or SN	Manufacturer	Power Cable
Laptop	Armada E 500	P31000T4X20DC12N2	Compaq	Laptop PS
Test Software	Atheros Radio Test		Atheros	"Zip" cord

Test Conditions

Temperature	15 C	Humidity:	49%
ATM pressure	1020 mBar	Grounding:	None
Tested By	J Martinez / C Byleckie	Date of Test:	Dec 2002
Test Reference	FCC Part 15.205 IC Paragraph RSS210, 6.2.3 (c)		
Setup Method	ANSI C63.4		
Tested Range	1 GHz to 40 GHz		
Test Voltage	120 VAC / 60 Hz		
Modifications	No modifications were made to the unit		

Results:

There were some emissions detected during the test. In the case of the "PEAK" measurement the RBW and VBW were always set to 1 MHz. The "AVG" test was conducted with the RBW = 1MHz and VBW = 10Hz.

Radiated emissions with device transmitting in the lower UNII band

Run #1b: Radiated Spurious Emissions,
1000 - 40000 MHz

EUT On Lowest Channel Available (5.18 GHz).

Frequency	Level	Pol	15.209 / 15.407		Detector	Azimuth	Height
MHz	dBmV/m	v/h	Limit	Margin	Pk/QP/Avg	degrees	meters
1166.658	37.9	V	54.0	-16.1	Pk	0	0.0
15540.54	62.2	V	74.0	-11.8	Pk	0	1.0
15539.42	49.3	V	54.0	-4.7	Avg	0	1.0
15540.36	62.0	H	74.0	-12.0	Pk	0	1.0
15540.02	48.9	H	54.0	-5.1	Avg	0	1.0

EUT On Center Channel (5.26 GHz).

6311.983	51.8	V	74.0	-2.2	Pk	0	1.0
6311.983	51.3	H	54.0	-2.7	Avg	0	1.0
15780.36	61.7	V	74.0	-12.3	Pk	0	1.0
15779.48	48.6	V	54.0	-5.4	Avg	0	1.0
15780.07	61.8	H	74.0	-12.2	Pk	0	1.0
15780.43	48.6	H	54.0	-5.4	Avg	0	1.0

EUT On Highest Channel Available (5.32 GHz).

10638.67	68.6	H	74.0	-5.4	Pk	330	1.2
10639.69	53.3	H	54.0	-0.7	Avg	330	1.2
15958.74	61.3	H	74.0	-12.7	Pk	0	1.0
15959.74	48.5	H	54.0	-5.5	Avg	0	1.0
10638.00	57.5	V	74.0	-16.5	Pk	0	0.0
10638.14	43.4	V	54.0	-10.6	Avg	0	0.0
15964.15	61.8	V	74.0	-12.2	Pk	0	0.0
15962.82	48.4	V	54.0	-5.6	Avg	0	0.0

Run #3b: Radiated Spurious Emissions, 1000 - 40000 MHz							
EUT On Upper UNII band, Lowest Channel Available							
(5.745 GHz) .							
Frequency	Level	Pol	15.209 / 15.407		Detector	Azimuth	Height
MHz	dBmV/m	v/h	Limit	Margin	Pk/QP/Avg	degrees	meters
11486.81	65.9	H	74.0	-8.1	Pk	5	1.1
11486.21	50.8	H	54.0	-3.2	Avg	5	1.1
11488.80	64.2	V	74.0	-9.8	Pk	0	1.2
11489.63	49.7	V	54.0	-4.3	Avg	0	1.2
4595.805	44.3	H	74.0	-29.7	Pk	0	1.0
4595.776	31.6	H	54.0	-22.4	Avg	0	1.0
4596.035	44.6	V	74.0	-29.4	Pk	0	1.0
4595.877	31.6	V	54.0	-22.4	Avg	0	1.0
EUT On Upper UNII band, Center Channel (5.765 GHz) .							
4611.107	44.0	V	74.0	-30.0	Pk	0	1.0
4611.632	31.3	V	54.0	-22.7	Avg	0	1.0
11531.05	66.9	V	74.0	-7.1	Pk	309	1.2
11530.30	51.8	V	54.0	-2.2	Avg	309	1.2
11528.72	69.3	H	74.0	-4.7	Pk	26	1.1
11528.93	53.5	H	54.0	-0.5	Avg	26	1.1
4610.823	43.9	H	74.0	-30.1	Pk	0	1.0
4610.170	31.3	H	54.0	-22.7	Avg	0	1.0
EUT On Upper UNII band, Highest Channel Available							
(5.805 GHz)							
11608.78	67.9	H	74.0	-6.1	Pk	310	1.1
11608.90	52.4	H	54.0	-1.6	Avg	310	1.1
4642.882	44.2	H	74.0	-29.8	Pk	0	1.0
4642.658	30.9	H	54.0	-23.1	Avg	0	1.0
4644.553	44.0	V	74.0	-30.0	Pk	0	1.0
4644.309	30.8	V	54.0	-23.2	Avg	0	1.0
11607.80	62.1	V	74.0	-11.9	Pk	0	0.0
11607.36	47.2	V	54.0	-6.8	Avg	0	0.0

Radiated Emissions in the Restricted bands

Ending at 5.15 GHz and beginning at 5.35 GHz

Procedure

There are three steps to performing this test.

STEP 1: Make a radiated measurement of the fundamental signal with the UUT on the highest channel. This measurement is used using the peak and average RBW and VBW of 1MHz/1MHz and 1MHz/10Hz. This measured radiated level is then used as a reference and is referred to as the *Fundamental Reference Measurement* in the table below

STEP 2: A measurement is made using narrower bandwidths (100 kHz) to determine a – dBc (delta dB) level between the fundamental reference level and the actual level at highest point in the restricted band. This delta dB is then subtracted from the radiated field strength reference measurement made earlier.

STEP 3 A third and final measurement is made to determine the apparent drop in fundamental carrier power when the RBW is narrowed from 1MHz (in the reference measurement) to 100kHz (for the delta dB measurement). This is referred to below as the “BW Delta”. This correction factor is only allowed in the highest emission in the restricted band is less than 2 “standard bandwidths” from the edge of the restricted band.

This measurement is made because it is the intent of the restricted band emission test to reference the measurement made in the restricted band to a radiated measurement made in a 1 MHz BW

This procedure is outline in FCC Public Notice DA 00-705, released on 30 March 2000 and is referred to as the “Marker-Delta Method”

The restricted bands that are of concern in the test are 4.5 – 5.15 GHz and 5.35 – 5.46GHz because these restricted bands are adjacent to one of the operating bands of the VAP.



The power setting of the VAP during this test was as shown in the power settings table.

A summary of the test results for each antenna at its applicable setting is presented on the next page. Note that the BW delta correction was not applied to the restricted band edge at 5.35 because the unit was within specification without applying this additional correction.

5.15 GHz UNII Band Edge (Restricted band @ 5.15GHz)

Chan	Pwr	Fundamental		Delta	RBW	Radiated Level at Band Edge		Specification		Delta Below Spec	
		Stg	Ref Msmt		Msmt	Delta	Peak	Avg	Peak	Avg	Peak
		Peak	Avg		msmt	Peak	Avg	Peak	Avg	Peak	Avg
		dBuV/m	dBuV/m	dBc	dB	dBuV/m	dBuV/m	dBuV/m	dBuV/m	dBuV/m	dBuV/m
Vert		115.9	106.7	47.8	7.5	60.6	51.4	74	54	13.4	2.6
Horz		107.8	98.2	47.8	7.5	52.5	42.9	74	54	21.5	11.1

5.35 UNII Band Edge (Restricted band @ 5.35GHz)

Chan	Pwr	Fundamental		Delta	RBW	Radiated Level at Band Edge		Specification		Delta Below Spec	
		Stg	Ref Msmt		Msmt	Delta	Peak	Avg	Peak	Avg	Peak
		Peak	Avg		msmt	Peak	Avg	Peak	Avg	Peak	Avg
		dBuV/m	dBuV/m	dBc	dB	dBuV/m	dBuV/m	dBuV/m	dBuV/m	dBuV/m	dBuV/m
Vert		112.2	103.4	50.17	NA	65.04	53.23	74	54	8.96	0.77
Horz		103.4	93.6	47.16	NA	56.24	43.43	74	54	30.6	10.6

5.15 band edge measurement showing Delta measurement and BW delta measurement.

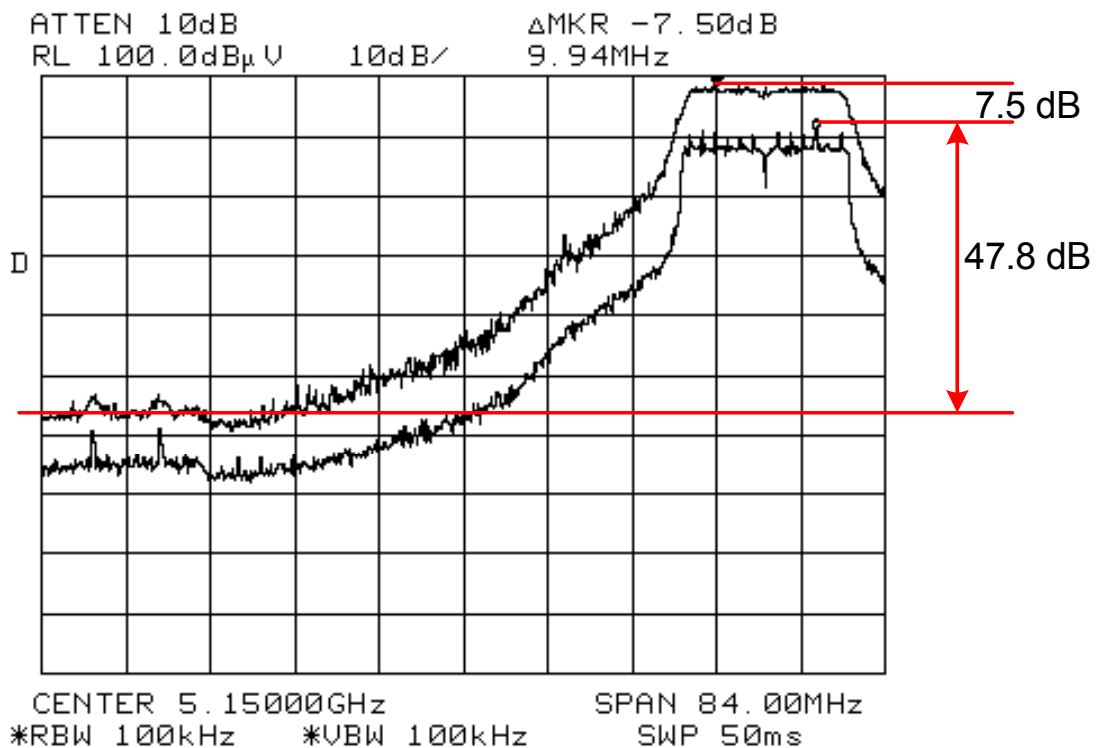

5.35GHz band edge peak delta measurement

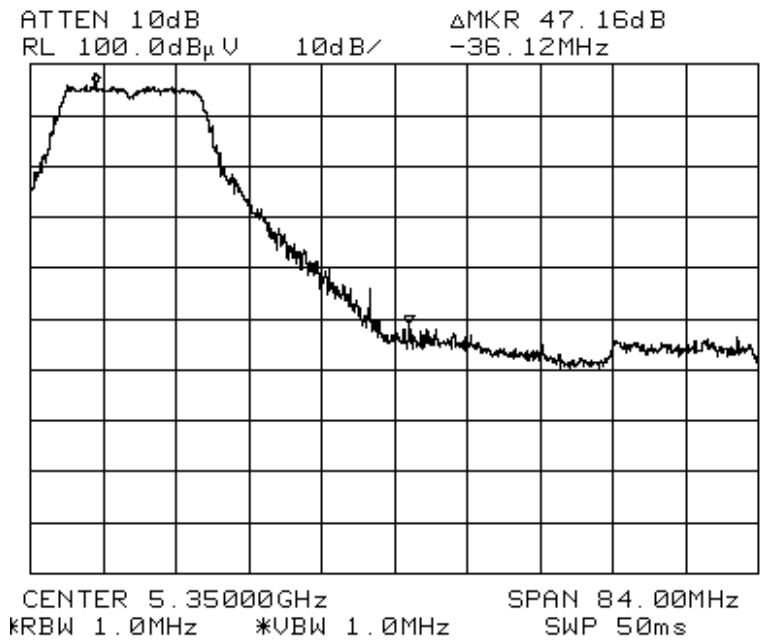

5.35GHz band edge peak delta measurement

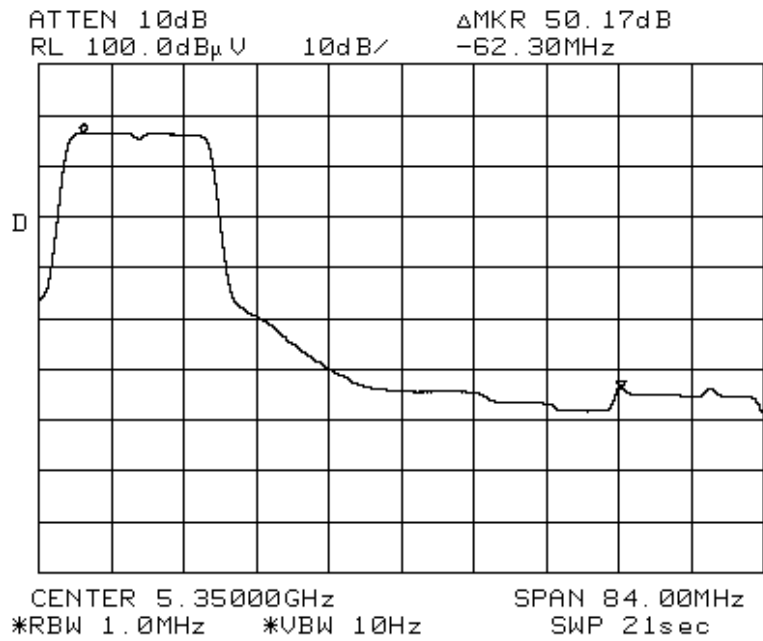

Radiated Emissions Sample Calculations

<p>Restricted band level (AVG) = AVG reference level - delta dB - BW Delta dB Restricted band level (Peak) = Peak reference level - delta dB - BW Delta dB</p>
--

Unwanted emissions outside of the restricted bands

Radiated spurious emissions occurring outside of restricted bands are subject to the field strength limits outlined in the table below. In all cases the limit that was applied to the spurious emissions was the restricted band limits which are lower than the allowed limits by 14.3 dB. Since all of the spurious emissions comply with the restricted band emission requirements, they also also comply with the limits below.

Freq Band (MHz)	EIRP Limit (dBm)	Equiv Field Strength (dBuV/M @ 3 meters)
5150 - 5250	-27	68.3
5250 - 5350	-27	68.3
5725 - 5825	-27 (note 1)	68.3
	-17 (note 2)	78.3

Note 1: for frequencies greater than 10 MHz above or below the the band edge

Note 2: All emissions between the band edge and 10 MHz above or below the band edge.

Note 3: The -27 or -17 dBm limit is converted to a field strength at 3 meters using the following formula:

$$E \text{ (dBuV/M @ 3M)} = \frac{1000000 \sqrt{30 * p \text{ (W EIRP)}}}{3}$$

AC Line Conducted Emissions

Specification:

FCC Specification: Paragraph CISPR 22

Procedure:

The test was set up according to the guidelines set forth in 15.207 and FCC Part 2 for AC Line Conducted Emissions. The measurement used a LISN line on each AC line and an EMI receiver. A peak scan was made over the measurement frequency range (150 kHz to 30 MHz). The highest peaks were then marked and re-measured and quasi-peaked and averaged.

The test was configured as shown below. The product was tested while running on 120 VAC @ 60 Hz .

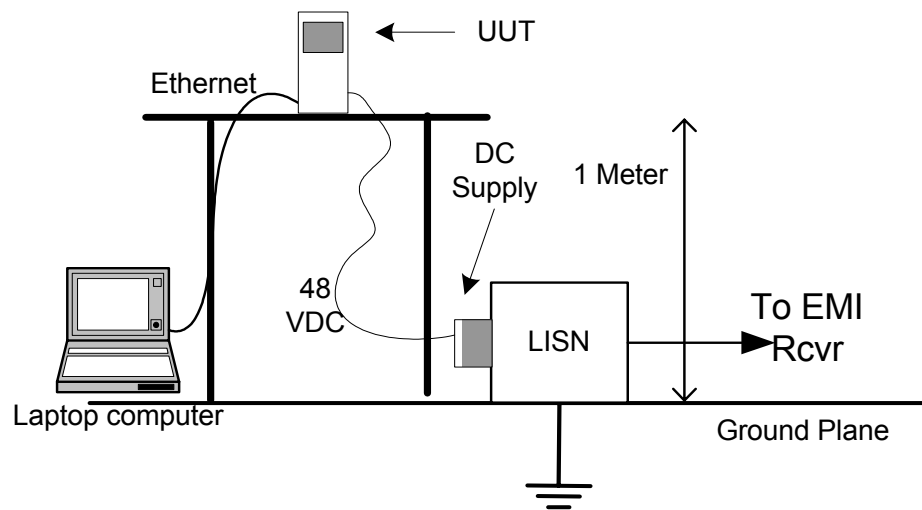

Results:

The "Quasi-peak" and Average results for the unit transmitting packets are contained on the following page. No emissions exceed the Class B limits.

AC Line Conducted Emission results

Freq (MHz)	Line Neutral	QP Level (dBuV)	Class B QP Spec (dBuV)	Delta (dB)	Freq (MHz)	Line Neutral	QP Level (dBuV)	Class B QP Spec (dBuV)	Delta (dB)
25.83	Line	40.97	60	19.03	25.65.	Neutral	40.05	60	19.95
26.35	Line	47.89	60	12.11	26.35	Neutral	43.48	60	16.52
26.62	Line	41.25	60	18.75	26.62	Neutral	42.53	60	17.47
26.85	Line	46.92	60	13.08	26.84	Neutral	46.86	60	13.14
27.10	Line	46.91	60	13.09	27.1	Neutral	43.35	60	16.65
27.29	Line	58.75	60	1.25	27.59	Neutral	48.14	60	11.86
27.60	Line	46.98	60	13.02	27.86	Neutral	41.28	60	18.72
27.83	Line	48.61	60	11.39	28/09	Neutral	46.23	60	13.77
28.12	Line	41.46	60	18.54	28.32	Neutral	48.92	60	11.08
29.58	Line	45.29	60	14.71	28.57	Neutral	45.20	60	14.80
Freq (MHz)	Line Neutral	AVG Level (dBuV)	Class B AVG Spec (dBuV)	Delta (dB)	Freq (MHz)	Line Neutral	AVG Level (dBuV)	Class B AVG Spec (dBuV)	Delta (dB)
25.83	Line	25.48	50	24.52	25.65.	Neutral	30.70	50	19.30
26.35	Line	30.23	50	19.77	26.35	Neutral	30.35	50	19.65
26.62	Line	31.44	50	18.56	26.62	Neutral	33.06	50	16.94
26.85	Line	34.26	50	15.74	26.84	Neutral	32.17	50	17.83
27.10	Line	29.6	50	20.40	27.10	Neutral	30.37	50	19.63
27.29	Line	36.12	50	13.88	27.59	Neutral	27.96	50	22.04
27.60	Line	28.64	50	21.36	27.86	Neutral	31.04	50	18.96
27.83	Line	29.91	50	20.09	28/09	Neutral	31.56	50	18.44
28.12	Line	34.03	50	15.97	28.32	Neutral	35.91	50	14.09
29.58	Line	32.43	50	17.57	28.57	Neutral	28.19	50	21.81