



110 Nortech Parkway
San Jose, CA, 95134
(408) 635 2000
www.airespace.com

FCC Part 15.247 Certification Application

**Industrie Canada RSS210 Certification
Application**

**EMI Test Report
on
IEEE 802.11 Access Point.
Models: 1200 & 1200INT**

**FCC ID: QTZ1200W
IC ID: 4518A-1200W**

Prepared by:
David Waitt
202 Calvert Drive #217
Cupertino, Ca. 95014
david@waitt.us
(408) 832 7053

Table of Contents

Section	Page
General Information.....	3
Detailed Product Information.....	4
<i>Internal Antenna Version.....</i>	<i>4</i>
<i>Internal / External Antenna Version.....</i>	<i>5</i>
Test Results Summary.....	6
Test Facilities.....	7
Equipment Lists.....	8
<i>Instrument Calibration.....</i>	<i>8</i>
<i>Elliott Test Equipment.....</i>	<i>8</i>
<i>Additional Test Equipment.....</i>	<i>8</i>
Test Methods.....	9
Test Results.....	10
<i>802.11 B Maximum RF Power Output at Antenna Terminals.....</i>	<i>11</i>
<i>6 dB and 99% Bandwidth.....</i>	<i>12</i>
<i>Power Spectral Density.....</i>	<i>16</i>
<i>Out of Band Emissions.....</i>	<i>20</i>
<i>Radiated Emissions In Restricted Bands.....</i>	<i>24</i>
<i>Radiated Emissions in Restricted bands (2.4 GHz Band Edges).....</i>	<i>33</i>
<i>AC Line Conducted Emissions.....</i>	<i>42</i>
<i>Receiver Spurious Radiated Emissions.....</i>	<i>44</i>

General Information

Unit(s) Under Test: IEEE 802.11 Access Point (AP)
Model(s): 1200W
1200INT
Product Description: IEEE 802.11 A/B/G Access point

FCC ID: QTZ1200W
IC ID: 4518A-1200W

Tested For: Airespace Inc.
110 Nortech Parkway
San Jose, CA 95134

Tested At: Elliott Laboratories
684 West Maude Ave
Sunnyvale, CA 94086

Tested By: Chris Byleckie, Sr. Test Engineer, Elliott Laboratories
Marissa Faustino, Test Engineer, Elliott Laboratories
David Waitt, (Independent Consultant)

Test Specifications: FCC CFR 47, Part 15.247, 2.4 GHz DSSS

Test Date: May 2004

Requested Certifications: FCC Part 15.247 Certification
IC RSS-210

Detailed Product Information

The access point radio is an IEEE 802.11 A/B/G Access point (AP) intended to be professionally installed and configured in corporate and industrial environments. There are two versions of the AP

- Internal Antennas only
- Internal / External Antennas

Detailed descriptions of the two versions is below

Internal Antenna Version

The AP utilizes integral antennas on the 802.11 B/G band. The access point effectively includes only a single 2.4GHz patch antenna, however, there are actually two 2.4 GHz antennas internal to the access point chassis. The module switches rapidly between the two antennas and when a signal is detected, the access point uses the antenna offering the best transmission characteristics. At any one time, there is only one antenna connected to the internal PCI module.

The effective gain of the 2.4 GHz internal antenna path is 7.8dBi. The diagrams below outline the RF path from the output of the RF circuitry to the integral antennas within the access point. The software within the internal antenna version shown below prohibits the switching of the FET antenna switches.

Not shown on the diagram below, but present on the actual AP are external antenna connectors mounted in the AP chassis. These external antenna connectors are present on the “internal antenna only version” to allow both versions to use the same chassis. These connectors are not present to facilitate a modification to the access point.

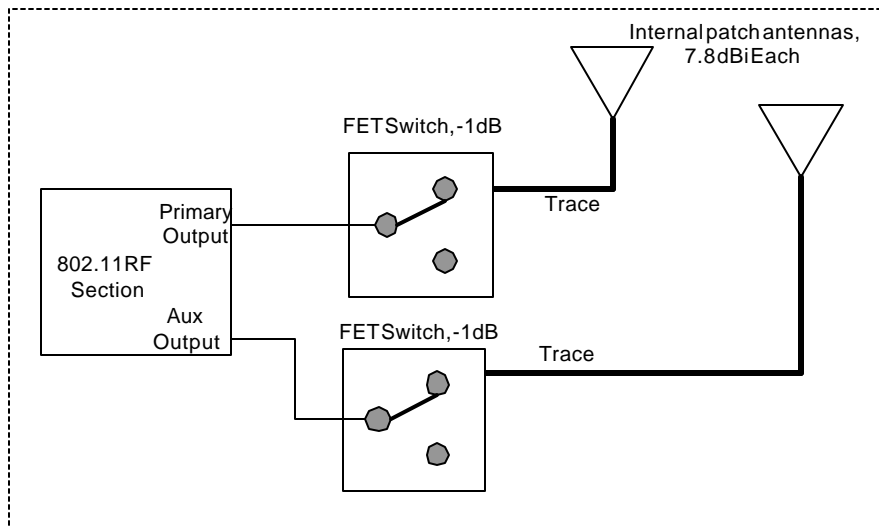

2.4 GHz RF Block Diagram (Internal Antenna Version)

Internal / External Antenna Version

Additionally, there is a version of the access point which allows connection of external antennas. When external antennas are connected to the access point, the configuration software switches the internal antenna switches into the EXT position. The antenna diversity functionality described earlier works in a similar manor to the internal antennas. The external antennas used with the access point must be “patch” type antennas and have a net effective gain (antenna gain - cable loss) equal to 7.8 dBi or less. At any one time, ONLY the internal or external antennas may be selected. It is NOT possible to configure the access point to rapidly toggle between external and internal antennas.

The only physical difference between the internal only version and the internal / external version of the access point is the addition of a small coax cable from the PCB to an external 15.203 compliant antenna connector in the chassis.

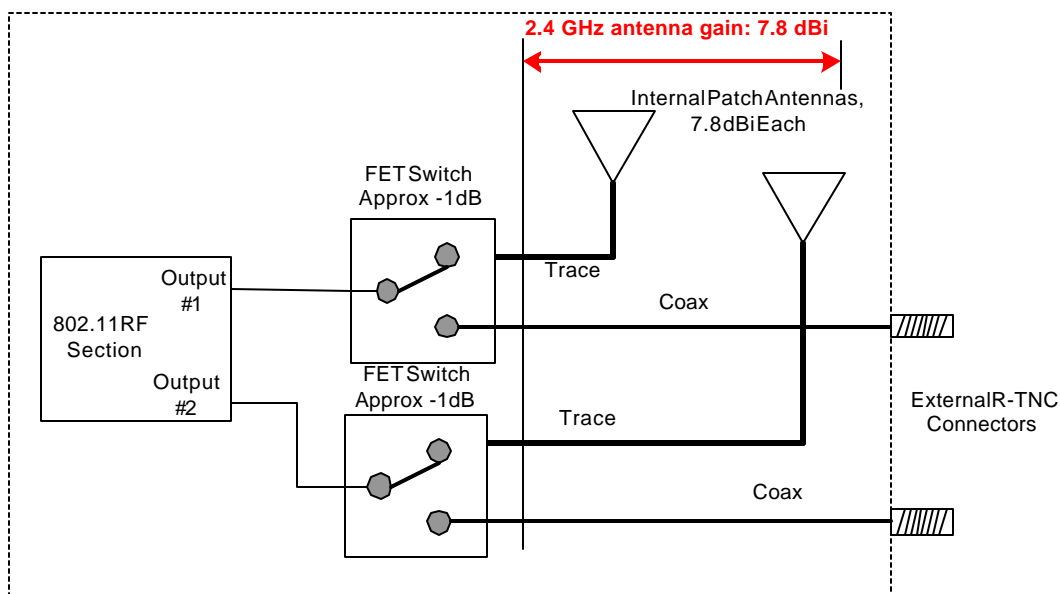

2.4 GHz RF Block Diagram (Internal / External Antenna Version)

Test Results Summary

This report presents the results of the tests that verify compliance with FCC Part 15.247 and

A brief results summary of all the in this report is below.

Part 15 Paragraph	RSS-210 Paragraph	Test	Results
15.247(b)	6.2.2(o)(a) 3	Maximum Power Output (802.11 B)	18.97 dBm Max
15.247(b)	6.2.2(o)(a) 3	Maximum Power Output (802.11 G)	17.77 dBm Max
15.247(a)(2)	6.2.2(o)(e1)	6dB Bandwidth (802.11 B)	13.63 MHz Min
15.247(a)(2)	6.2.2(o)(e1)	6dB Bandwidth (802.11 G)	16.5 MHz Min
15.247(d)	6.2.2(o)(d1)	Power Spectral Density (802.11 B)	-4.61dBm/3kHz Max
15.247(d)	6.2.2(o)(d1)	Power Spectral Density (802.11 G)	--2.86 dBm/3kHz Max
15.247(c)	6.2.2(o)(a) 4	Out of Band Spurious Emissions	None Detected
15.205	6.3(c)	Radiated Emissions in Restricted bands	.6 dB in spec min @7384.73 MHz (802.11 G)

Test Facilities

The radiated emissions tests were performed at:

Elliott Labs
684 West Maude Ave
Sunnyvale, CA 94086

The tests performed at Elliott include:

- All radiated emissions tests required in FCC Part 15.205 for 2.4 GHz.
- Out of band emissions (Conducted) (for 2.4 GHz)

General:

Final 802.11 B radiated test measurements were taken at Elliott Laboratories Chamber #5.

The test site contains separate areas for radiated and conducted emissions testing. Pursuant to section 2.948 of the Rules, construction, calibration, and equipment data has been filed with the Commission.

The FCC recommends that ambient noise at the test site be at least 6 dB below the allowable limits. Ambient levels are below this requirement with the exception of predictable local TV, radio, and mobile communications traffic. The test site contains separate areas for radiated and conducted emissions testing. Considerable engineering effort has been expended to ensure that the facilities conform to all pertinent FCC requirements.

OATS:

The FCC has determined that radiation measurements made in a shielded enclosure are not suitable for determining levels of radiated emissions. Radiated emissions are performed in an open field environment. The test site is maintained free of conductive objects within the CISPR defined elliptical area incorporated in ANSI C63.4 Guidelines.

Antenna, Antenna Mast and Turntable

The Horn antennas that are used to measure radiated emissions above 1000MHz are mounted on a non-conductive antenna mast equipped with a motor drive to vary the antenna height.

ANSI C63.4 specifies that the test height above the ground plane shall be 80cm unless the equipment is intended to be floor mounted. During the radiated emissions tests the equipment is positioned on a motorized turntable in conformance with the ANSI requirement.

Equipment Lists

Instrument Calibration

All test equipment is regularly checked to ensure that performance is maintained in accordance with the manufacturer's specifications. All antennas are calibrated at regular intervals with respect to tuned half-wave dipoles. An exhibit of this report contains the list of test equipment used and calibration information.

The following test equipment was used to perform the testing

Elliott Test Equipment

<u>Manufacturer</u>	<u>Description</u>	<u>Model #</u>	<u>Asset #</u>	<u>Cal Due</u>
Hewlett Packard	Microwave Preamplifier, 1-26.5GHz	8449B	263	09-Jan-05
EMCO	Horn Antenna, D. Ridge 1-18GHz	3115	868	20-Apr-06
Hewlett Packard	Microwave EMI test system (SA40, 9kHz - 40GHz) Fremont	84125C	1410	26-Mar-05
Hewlett Packard	EMC Spectrum Analyzer 9KHz-26.5GHz, non programmable	8563E	284	15-Mar-05
Rohde & Schwarz	Power Meter, Single Channel	NRVS	1290	22-Apr-05
Rohde & Schwarz	Peak Power Sensor 100uW - 2 Watts	NRV-Z32	1536	22-Apr-05

Additional Test Equipment

<u>Item</u>	<u>Desc.</u>	<u>Manufacturer</u>	<u>Model</u>	<u>S/N</u>	<u>Cal due date</u>
1.	Spectrum Analyzer	Agilent	E4440A	MY43362314	16 Jan 2005

Test Methods

The tests are performed at a low, middle and high channel of the applicable band. The typical frequencies used for the Part15.247 2.4 GHz tests are shown in the table to the right. Unless otherwise noted, all testing was performed on these channels / frequencies

ISM 802.11 B / G		
2400 – 2483.5 MHz		
Channel		Freq(MHz)
Low	Chan 1	2412
Mid	Chan 6	2437
High	Chan 11	2462

In order to comply with the “radiated emissions in restricted bands” requirements the transmit power had to be lowered on some of the channels at the edges of the operating band. The maximum power setting that allowed compliance with the radiated emissions requirements will be programmed into the configuration firmware of the access point ensuring that maximum possible power setting will be correct for each channel.

Given that the access point will normally be operated at these power settings, these same settings were also used during the “bench top” conducted RF tests (Spectral density, bandwidth etc).

The tests listed below are performed using the basic “conducted” test setup shown below unless otherwise noted. In most cases, the EUT was running special diagnostic software to allow it to transmit random data on a particular channel indefinitely.

Part 15	Test
15.247(a)(1)	6dB / 99% Bandwidth
15.247(c)	Out of Band Conducted Emissions
15.247(a)(1)(i)	Power Spectral Density
15.247(b)	Transmit Power

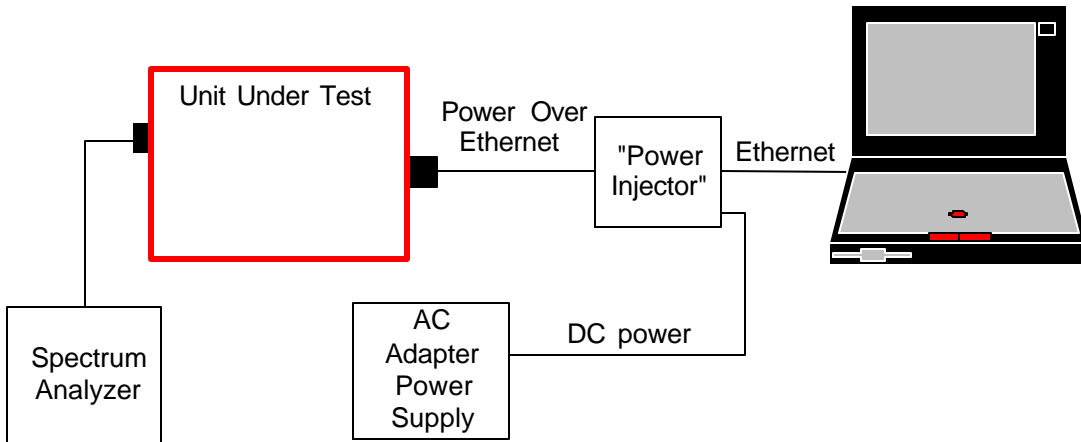

Basic Conducted RF Bench Test Setup

Unless otherwise noted, the support equipment for the bench tests is listed below.

Support Equipment				
Description	Model number	FCC ID or SN	Manufacturer	Power Cable
Laptop	Armada E 500	P31000T4X20DC12N2	Compaq	Laptop PS
Test Software	Atheros Radio Test		Atheros	
48VDC AC adapter	Generic		Generic	Standard Twin lead DC wire

NOTE: The “Power Injector” is simply a connector attached to wires “broken out” of the Ethernet cable. It is not really a piece of equipment.

Test Results

Detailed test procedures and test results are contained in the following sections. In cases where the test setup differs from the Conducted RF test setup shown earlier, the test setup is also presented.

Test Conditions			
Temperature	17C	Humidity:	40%
ATM pressure	1015 mBar	Grounding:	None
Tested By	David Waitt	Date of Test:	May 2004
Test Reference	Refer to individual test results		
Tested Range	Test Dependent		
Test Voltage	48 VDC to the AP		
Modifications	No modifications were made to the unit during the tests		

802.11 B Maximum RF Power Output at Antenna Terminals

Specifications:

FCC Specification: Paragraph: 15.247(b)

IC Specification: RSS-210, 6.2.2.(o)(b)

Procedure:

The test was configured as shown in the conducted RF test setup. The unit was tuned to the test channels and configured to transmit random data packets. The integration bandwidth of the spectrum analyzer was then set to the previously measured 20 dB bandwidth of the signal. The integrated channel power was then measured over that bandwidth.

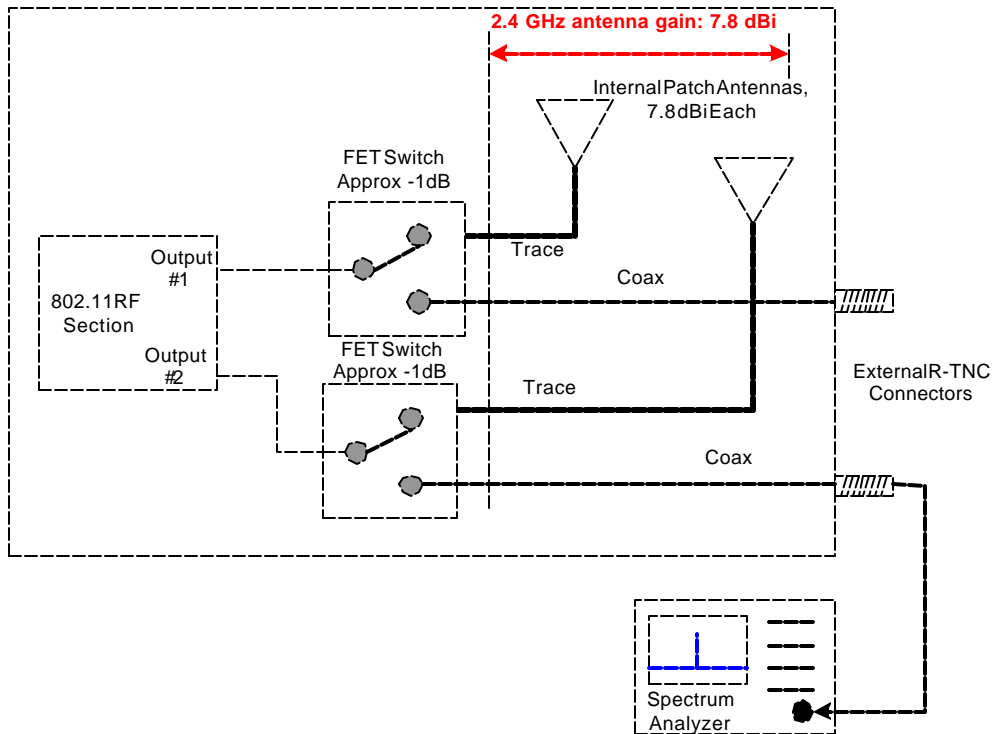

Result:

The power levels below reflect the power into the antenna due to the fact that the power out of the external connector is the same as into the antenna. The power measurements listed in the tables above are also applicable for the power into the external antennas if used with the product

NOTE: The power was reduced on 802.11 B Channel 1 (2412 MHz) band edge to comply with restricted band radiated emissions requirements at 2390 MHz.

Freq (MHz)	802.11 B			802.11 G			EIRP Spec (dBm)	Min Spec Delta (dB)
	Power into antenna (dBm)	Power into antenna (mW)	Xmit Power (dBm EIRP)	Power into antenna (dBm)	Power into antenna (mW)	Xmit Power (dBm EIRP)		
2412	16.48	44.46	24.28	17.10	51.29	24.90	36.00	11.10
2437	18.77	75.34	26.57	17.30	53.70	25.10	36.00	9.43
2462	18.97	78.89	26.77	17.77	59.84	25.57	36.00	9.23

6 dB and 99% Bandwidth

Specifications

FCC Specification: Paragraph 15.247(a)(2)

IC Specification: RSS-210 .6.2.2(o)

Procedure:

The access point operates on the standard IEEE 802.11 A / B channels. The 6dB bandwidth was measured on the low middle and high channel of the 2.4 GHz ISM band using the conducted RF test setup. The spectrum analyzer was configured for MAX HOLD and the trace allowed to stabilize. A peak search was performed and the then “Delta-Marker” used to locate the points at -6dB below the peak. Additionally, the “Channel Bandwidth” function of the spectrum analyzer was used to measure the 99% occupied bandwidth

The bandwidth test was performed at the power settings that will be used in the final system.

Results:

Freq (MHz)	802.11 B Bandwidth (MHz)		802.11 G Bandwidth (MHz)		Spec (MHz)	Delta (min)
	6 dB	99%	6 dB	99%		
2412	13.63	15.57	16.50	16.57	0.50	13.13
2437	12.50	15.58	16.50	16.57	0.50	12.00
2462	12.70	15.55	16.50	16.57	0.50	12.20

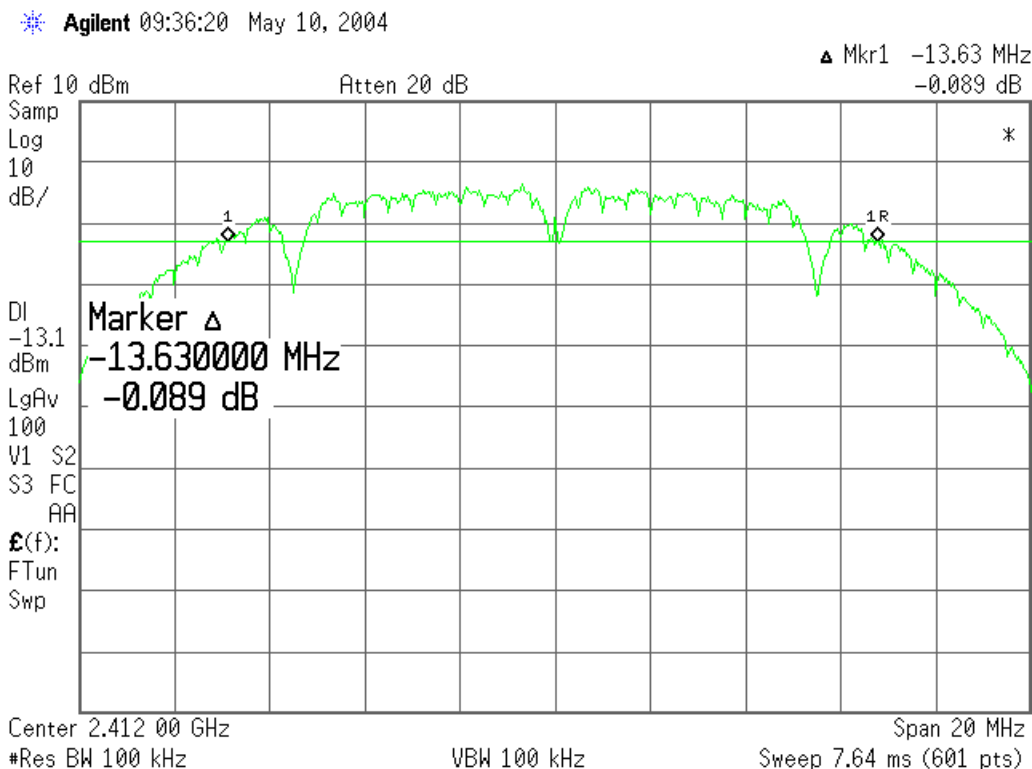

802.11B - 6 dB BW @ 2412 MHz

Agilent 09:38:02 May 10, 2004

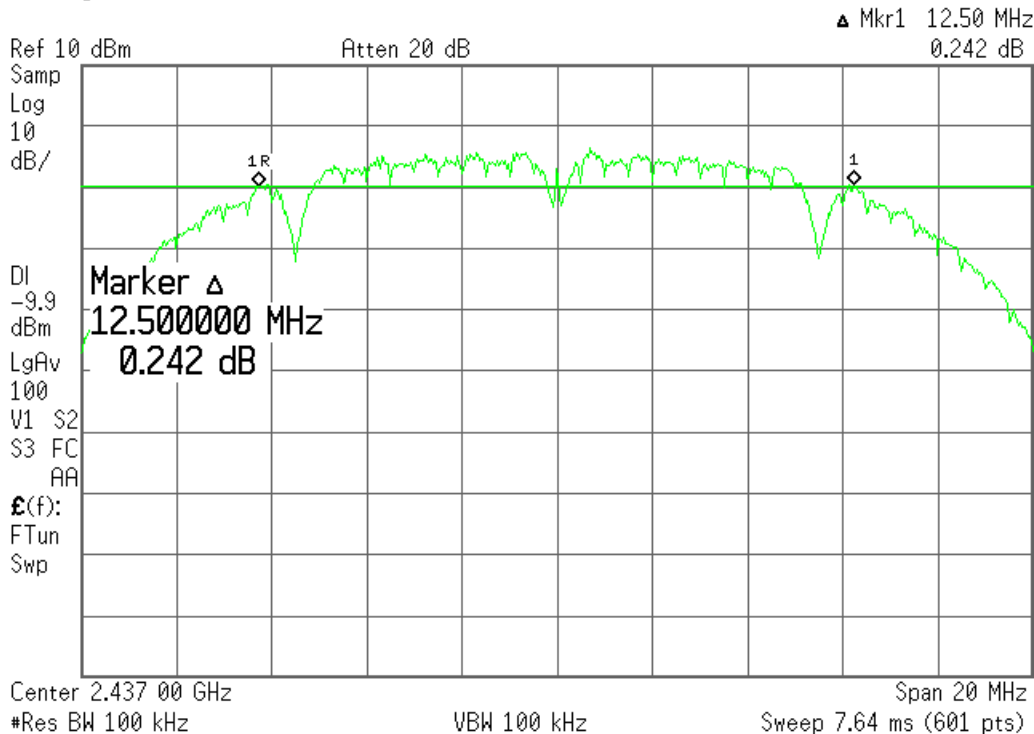

802.11B - 6 dB BW @ 2437 MHz

Agilent 09:39:40 May 10, 2004

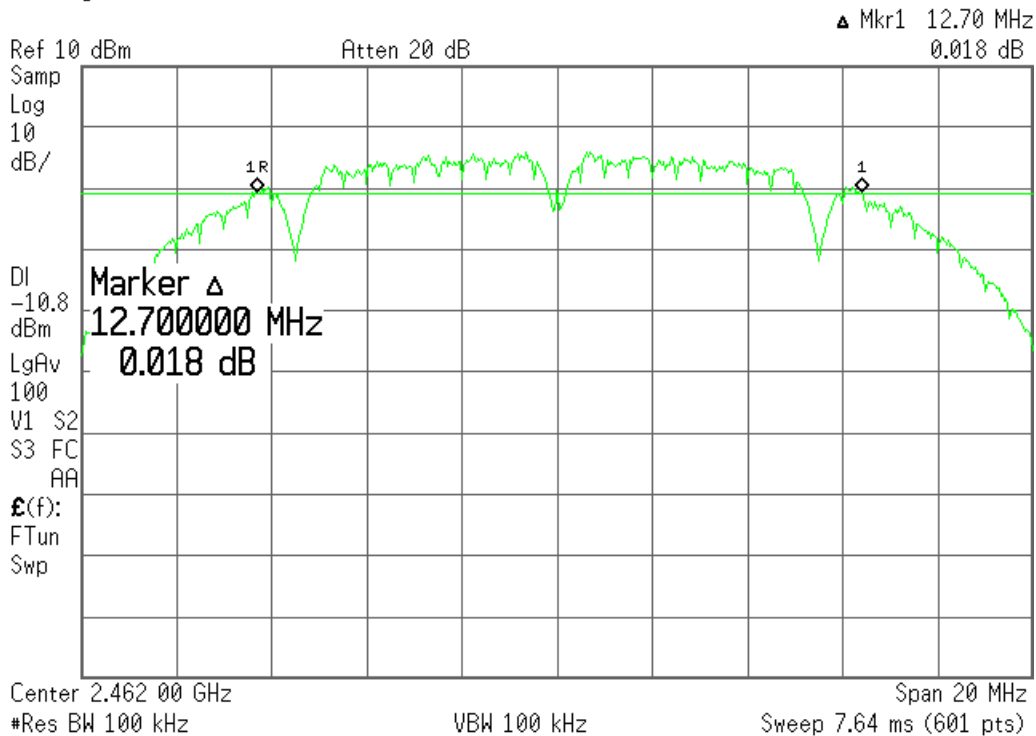

802.11B - 6 dB BW @ 2462 MHz

Agilent 09:57:54 May 10, 2004

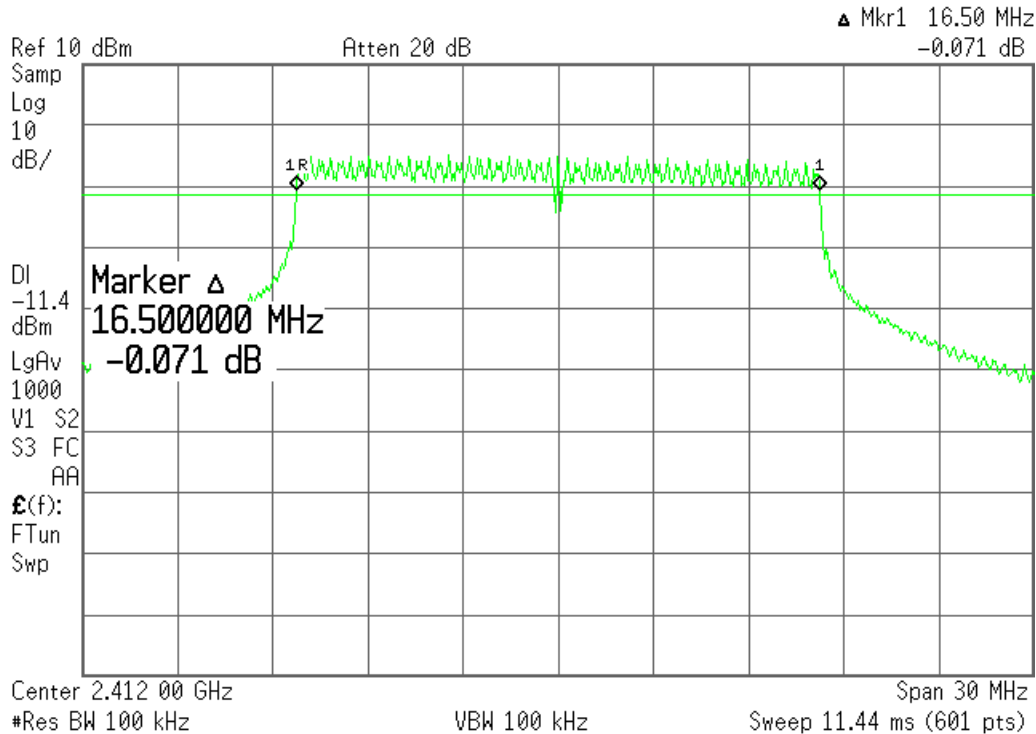

802.11G - 6 dB BW @ 2412 MHz

Agilent 09:56:32 May 10, 2004

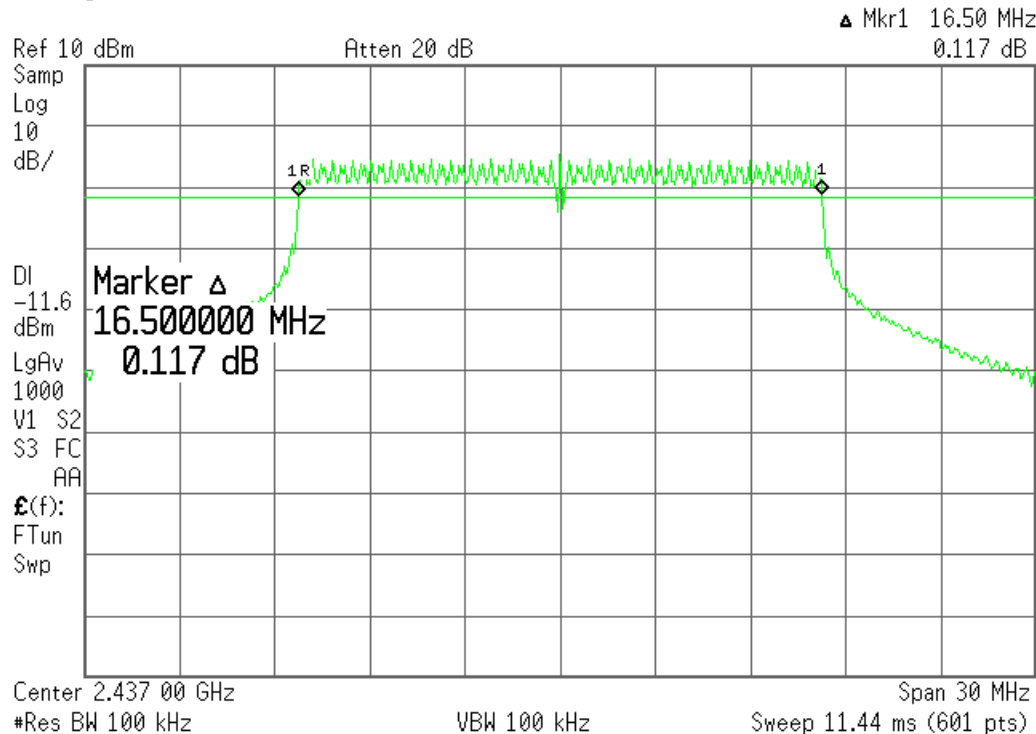

802.11G - 6 dB BW @ 2437 MHz

Agilent 09:51:24 May 10, 2004

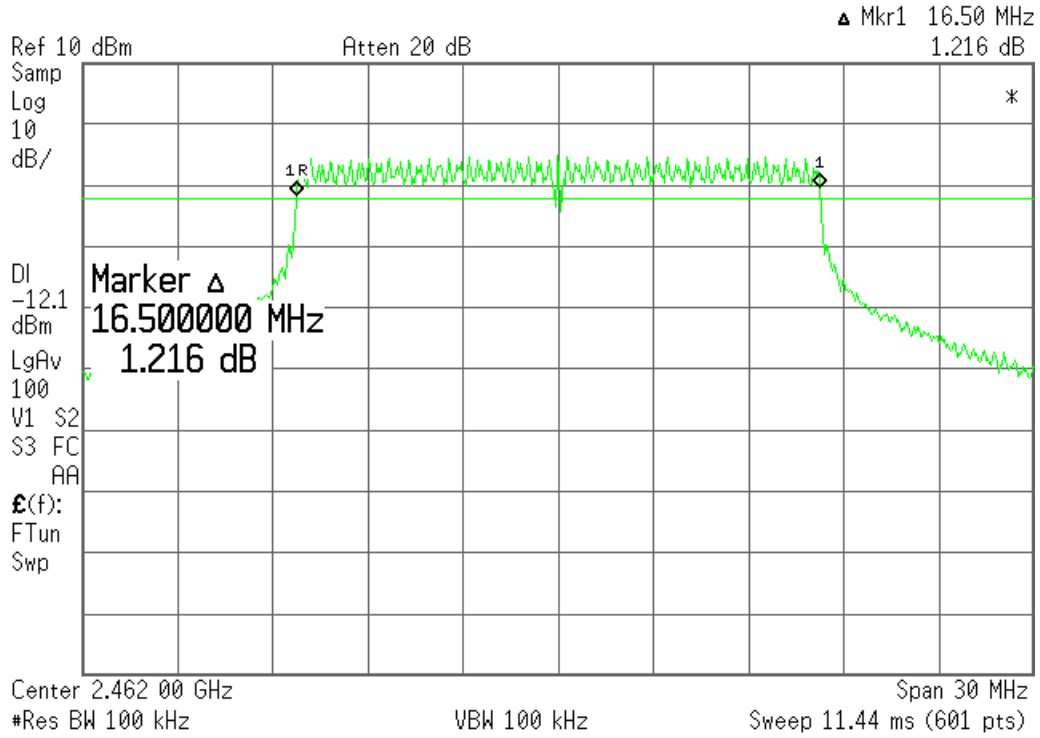

802.11G - 6 dB BW @ 2462 MHz

Power Spectral Density

Specifications:

FCC Specification: Paragraph 15.247(4)(d)

IC Specification: RSS-210 .6.2.2(o)(b)

Procedure:

The test setup was configured as shown in the conducted test setup. The UUT was configured to continuously transmit random data packets. Initially the bandwidth of the entire channel was examined. Using MAX HOLD, the trace was allowed to stabilize. Once the trace was stable, a peak search was performed and the frequency with the maximum power was determined.

The measurement span was then narrowed to 300kHz and centered on the “MAX power” frequency, the RBW set to 3 kHz with a 100 second sweep. The analyzer was then set to MAX HOLD and a display line placed at +8dBm.

The power spectral density was measured at the low, middle and high-test channels with the appropriate power setting for the given test channel.

Results:

Frequency MHz	Specification (dBm/3 kHz)	802.11 B Measured PSD (dBm)	Spec Delta 802.11 B dB min	802.11 G Measured PSD (dBm)	Spec Delta 802.11 G dB min
2412	8	-8.74	16.74	-2.86	10.86
2437	8	-4.61	12.61	-3.75	11.75
2462	8	-6.32	14.32	-7.35	15.35

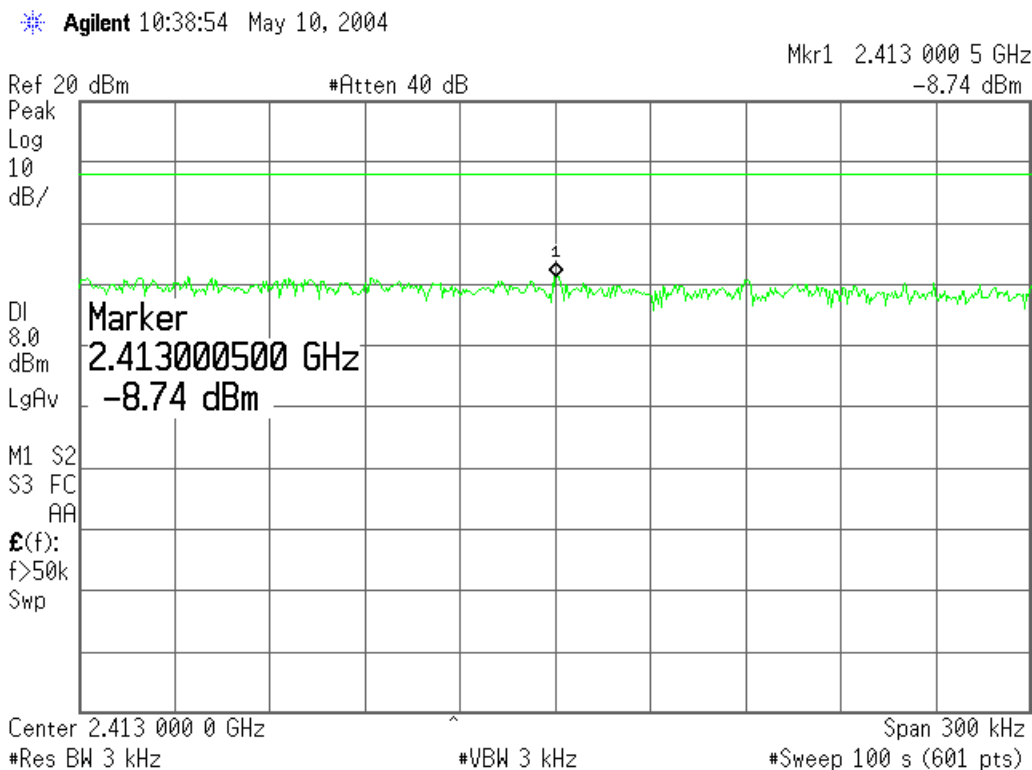

Power Spectral Density,802.11 B LOW Channel, 2412MHz

Agilent 10:42:50 May 10, 2004

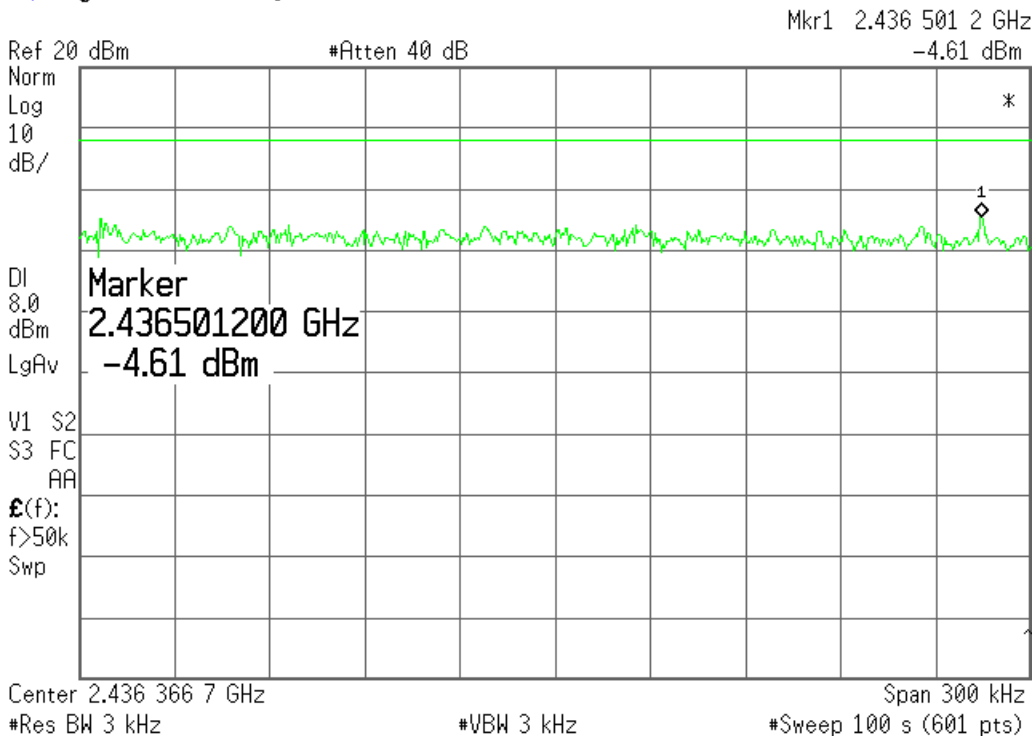

Power Spectral Density,802.11 B MID Channel, 2437 MHz

Agilent 10:48:30 May 10, 2004

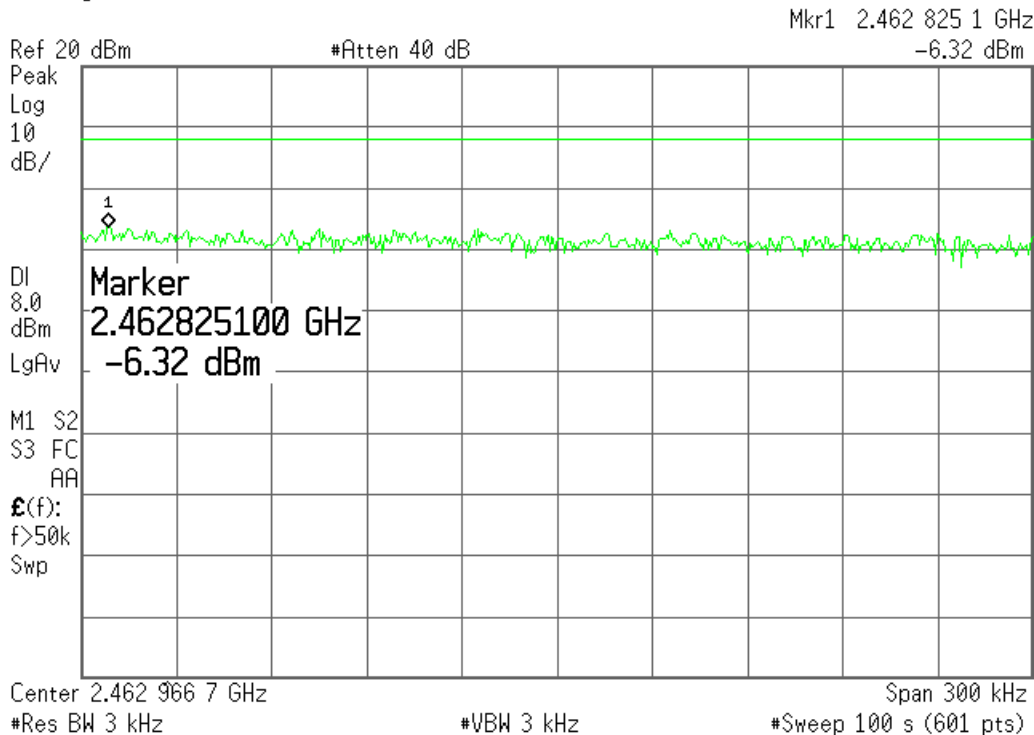

Power Spectral Density,802.11 B HIGH Channel, 2462 MHz

Agilent 11:03:33 May 10, 2004

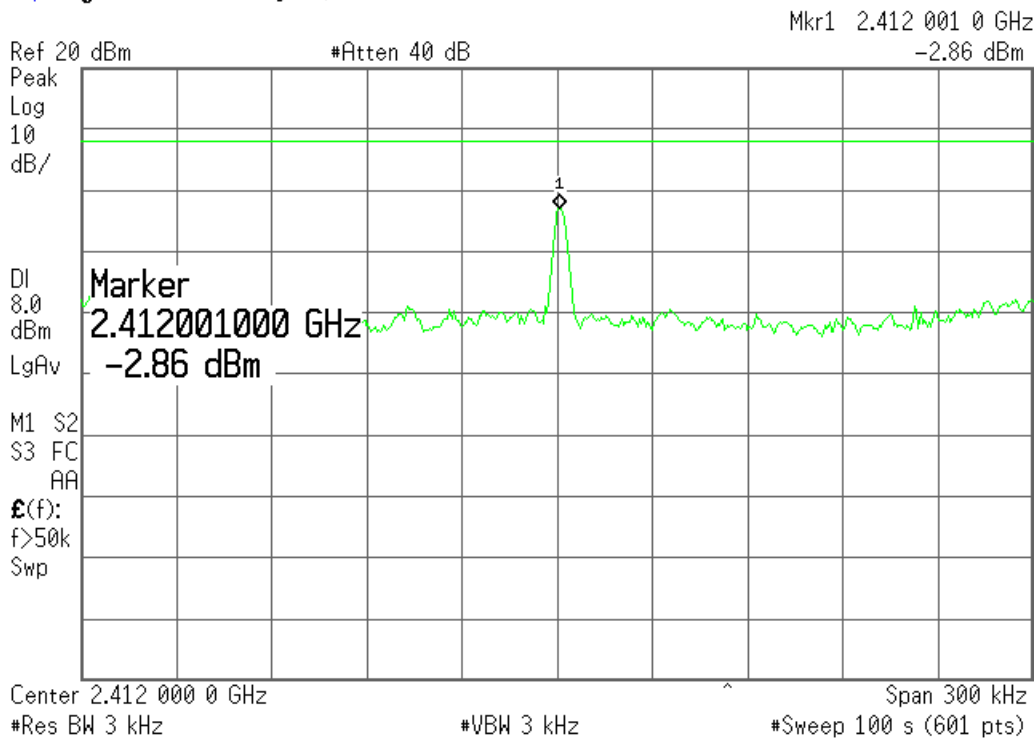

Power Spectral Density,802.11 G LOW Channel, 2412 MHz

Agilent 10:59:17 May 10, 2004

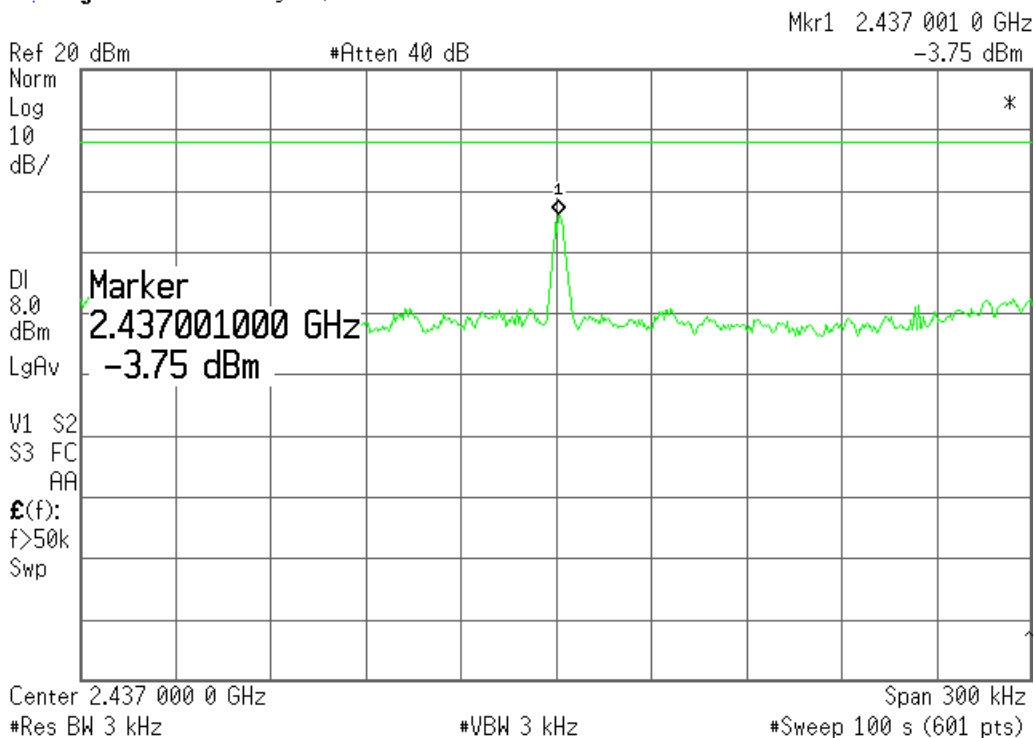

Power Spectral Density,802.11 G MID Channel, 2437 MHz

Agilent 10:52:29 May 10, 2004

Mkr1 2.465 404 0 GHz
-7.35 dBm

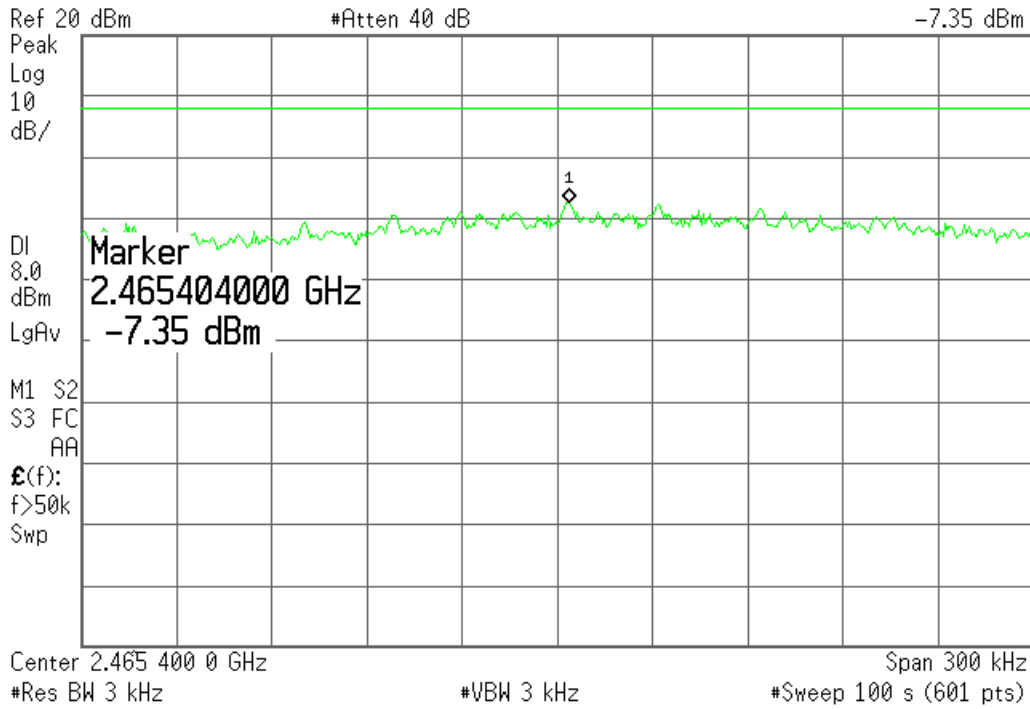

Power Spectral Density, 802.11 G HIGH Channel, 2462 MHz

Out of Band Emissions

Specifications:

FCC Specification: Paragraph 15.247(c)

IC Specification: RSS-210 .6.2.2(o)(e1)

Procedure:

The test was configured as shown in the bench conducted RF test setup. The UUT was configured to transmit random data packets. The band from 1 GHz to 25GHz was examined for spurious emissions. This test was conducted the low middle and high channels. The UUT was configured to transmit at the appropriate power levels for each channel (1 , 6 and 11) that was used in the RF power test.

Results:

The entire band of interest was examined at one time to clearly demonstrate compliance. There were no spurious emissions above the limit (-20dBc).

802.11 B operation showed no noticeable emissions.

802.11 G operation showed a noticeable second harmonic that was investigated during the radiated emissions in restricted band test. No other emissions were noted during the test.

The display line in the following plots is set to the -20dBc level corresponding to each channels fundamental signal level.

Out of Band Emissions Plots

Agilent 10:22:57 May 10, 2004

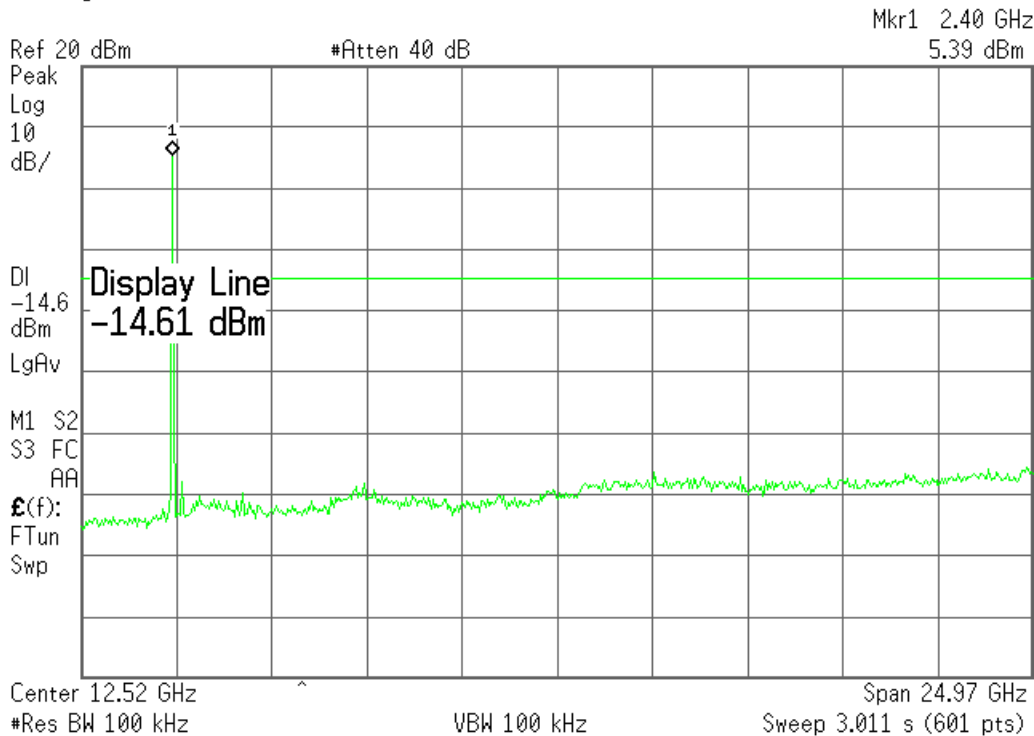

OOB Emissions, 802.11 B Transmit on Channel 1 (2412MHz) (30 MHz - 25 GHz)

Agilent 10:22:06 May 10, 2004

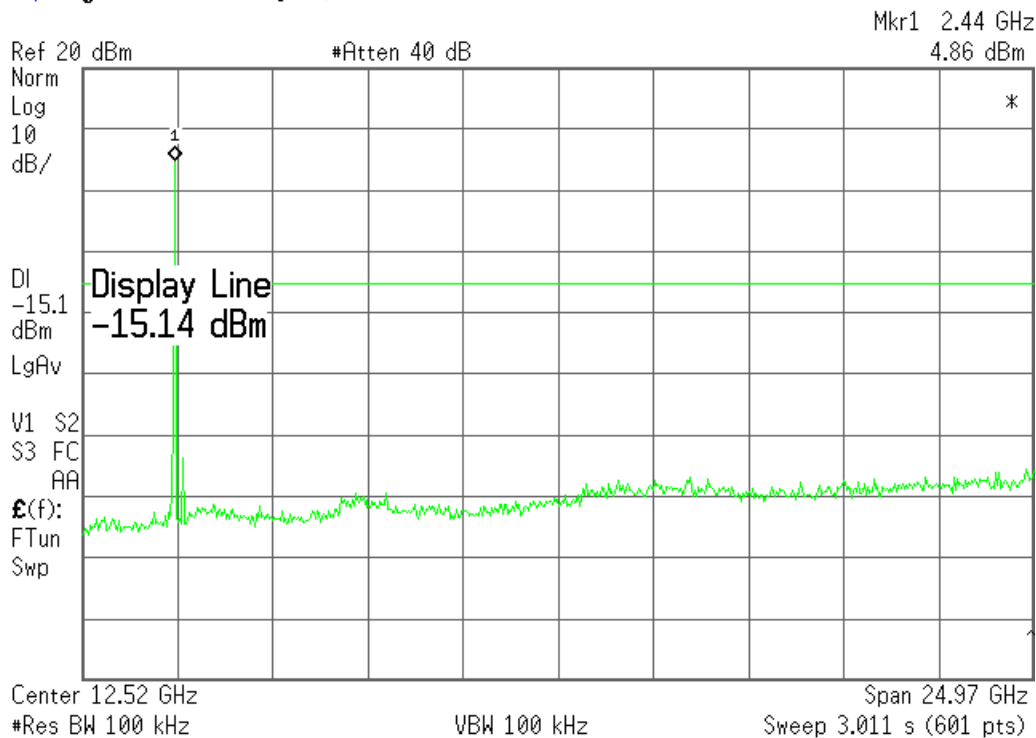

OOB Emissions, 802.11 B Transmit on Channel 6 (2437MHz) (30 MHz - 25 GHz)

Agilent 10:21:08 May 10, 2004

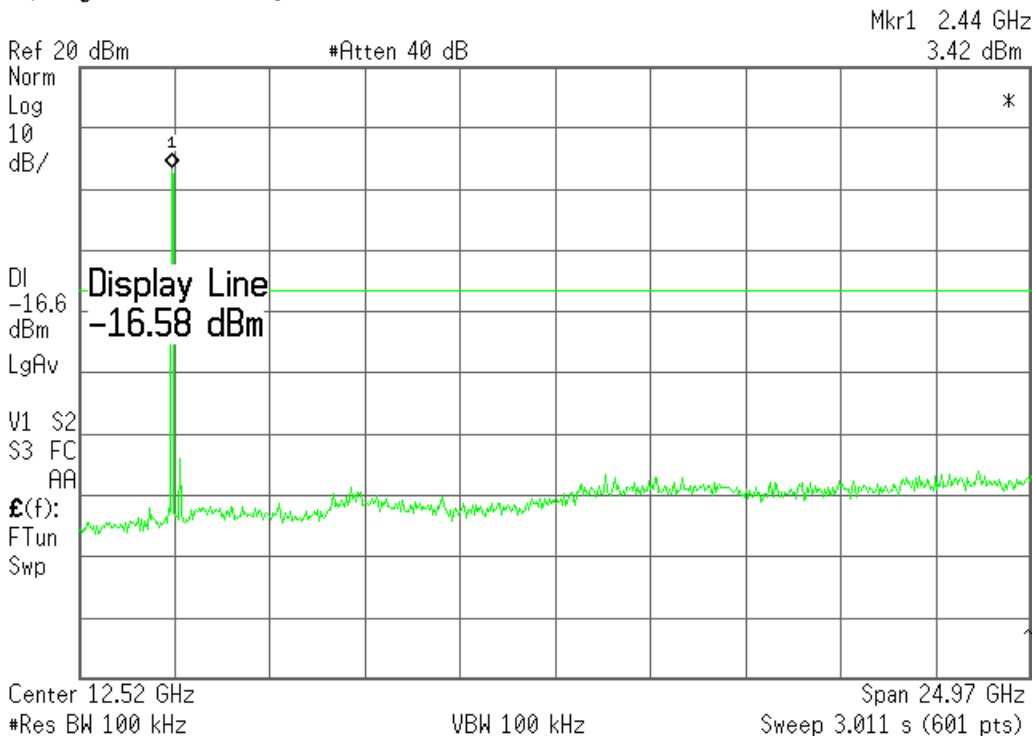

OOB Emissions, 802.11 B Transmit on Channel 11 (2462MHz) (30 MHz - 25 GHz)

Agilent 10:17:10 May 10, 2004

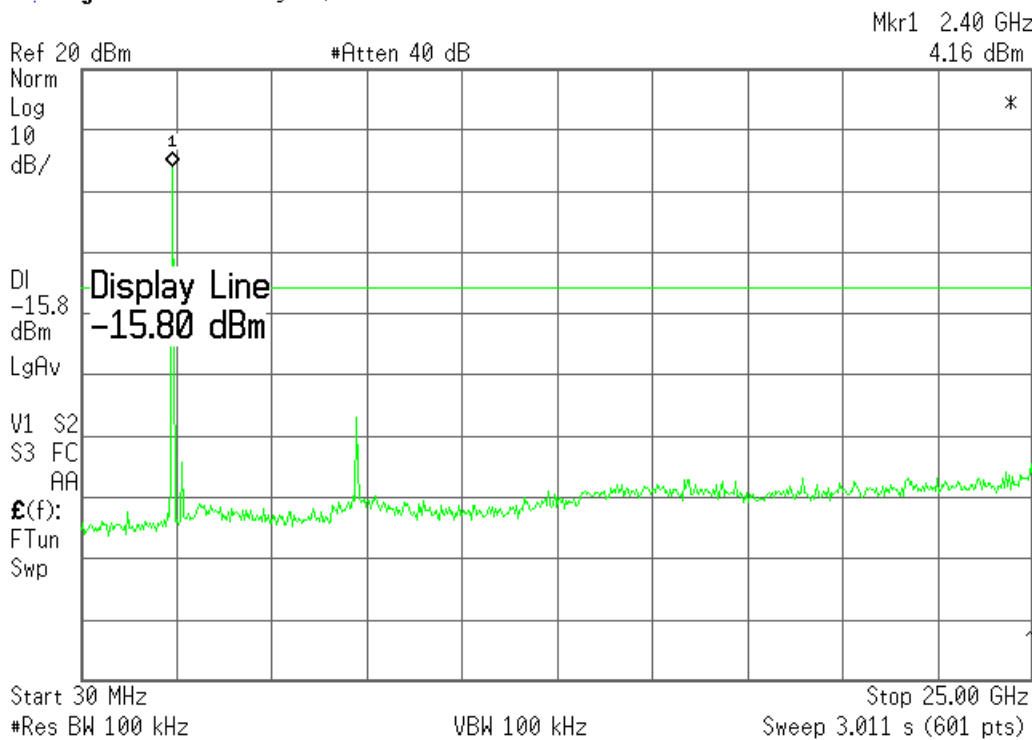

OOB Emissions, 802.11 G Transmit on Channel 1 (2412MHz)

Agilent 10:18:41 May 10, 2004

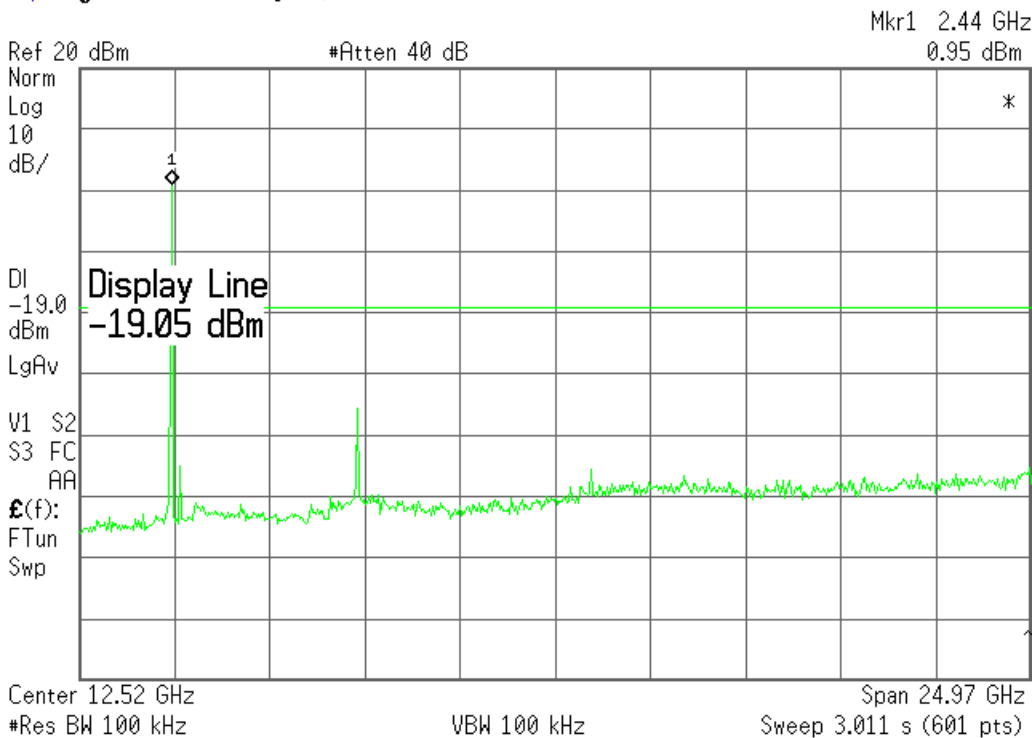

OOB Emissions, 802.11 G Transmit on Channel 6 (2437 MHz)

Agilent 10:17:10 May 10, 2004

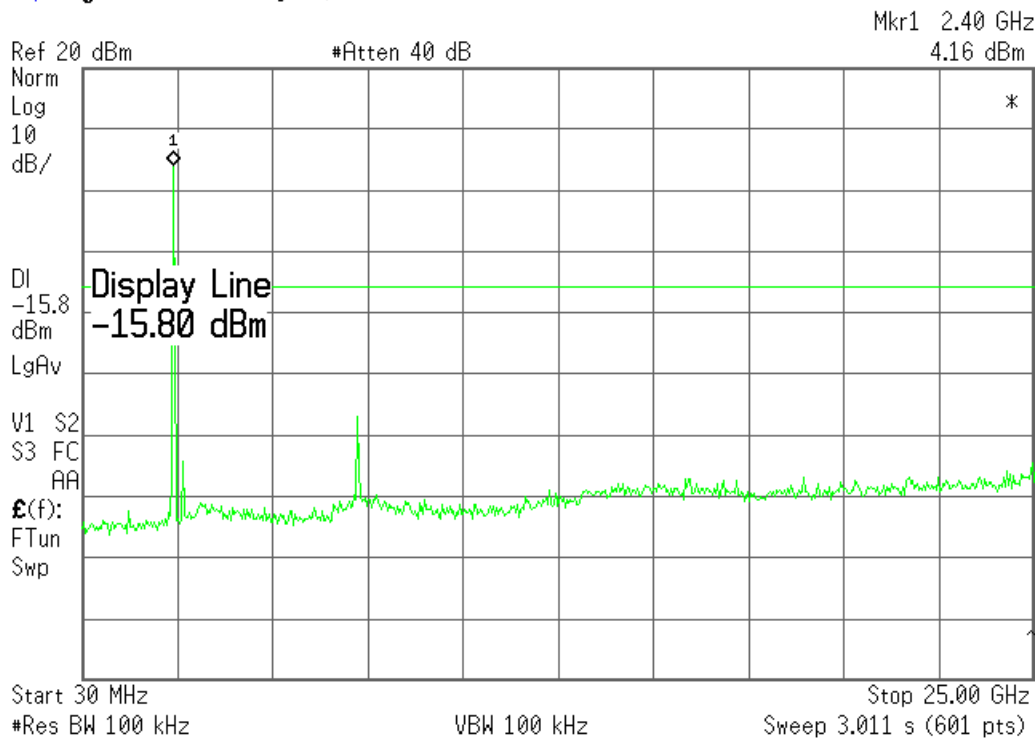

OOB Emissions, 802.11 G Transmit on Channel 11 (2462MHz)

Radiated Emissions In Restricted Bands

Specifications:

FCC Specification: Paragraph 15.247(c)

IC Specification: RSS-210 6.3(c)

Procedure:

This test was conducted inside a semi-anechoic chamber at Elliott Laboratories. The unit was placed on a rotating wooden table 80cm above the ground plane. A Horn antenna was secured to a mast 3 meters away. The unit was tested at each of the Low, Mid and High channels. The UUT was running in the diagnostic mode and set to transmit at maximum power on each of the channels. The test equipment was configured as shown below.

The harmonics of the fundamental that fell within restricted bands (up to the tenth) were measured (See table 1 below). A high pass filter prior to the pre-amplifier was required to prevent the large signal level of the fundamental frequency from overloading the front end of the spectrum analyzer and creating harmonics within the analyzer.

The EUT was rotated 360 degrees and the height of the antenna adjusted from 1 to 4 meters above the ground plane to determine the maximum level of the emission. The level of the harmonic emission was measured in two modes, "Peak" and "Average".

The spectrum analyzer reading made by the test software and the appropriate correction factors (antenna factor, cable loss, pre-amplifier gain, HPF loss...) were then applied by Elliott Lab's Software to obtain a final corrected measurement.

This procedure was repeated for the low (Ch 1), mid (Ch 6) and high (Ch 11) channels within the 2400-2483.5MHz band.

The band up to 25 GHz was examined, however there were no spurious emissions noted above approximately 12 GHz., additionally, the only visible emissions were harmonics of the transmit frequency.

The table below indicates the harmonics that fall within restricted bands.

FUND	Harmonic (MHz)								
	2	3	4	5	6	7	8	9	10
2412	4824	7236	9648	12060	14472	16884	19296	21708	24120
2437	4874	7311	9748	12185	14622	17059	19496	21933	24370
2462	4924	7386	9848	12310	14772	17234	19696	22158	24620

15.205 Harmonic test tables

NOTE: RED indicates a harmonic that falls within a restricted band and is subject to 15.205. The harmonics in black are NOT in restricted bands and are subject to 15.209

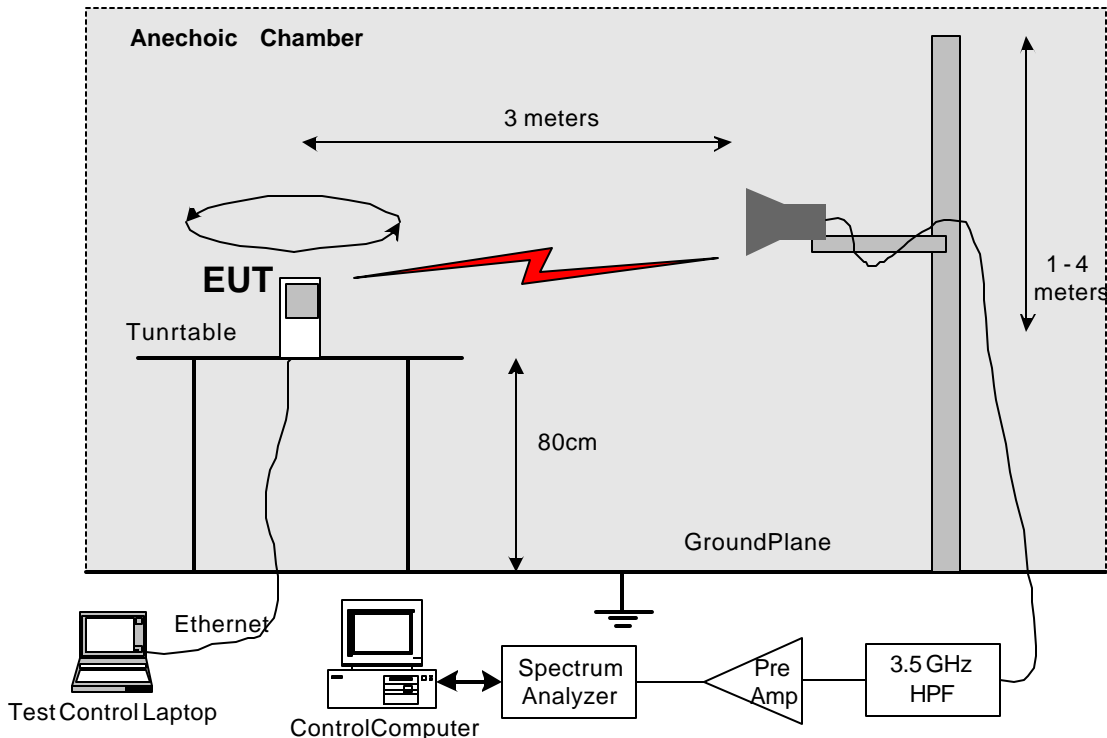

Radiated Emissions in Restricted Bands Test Setup

Support Equipment				
Description	Model number	FCC ID or SN	Manufacturer	Power Cable
Laptop	Armada E 500	P31000T4X20DC12N2	Compaq	Laptop PS
Test Software	Atheros Radio Test		Atheros	
48VDC AC adapter	Generic		Generic	Standard Twin lead DC wire

Test Conditions			
Temperature	19.8 C	Humidity:	41%
ATM pressure	1022 mBar	Grounding:	None
Tested By	M Faustino Elliott Labs	Date of Test:	May 2004
Test Reference	FCC Part 15.205 IC Paragraph RSS210, 6.2.3 (c)		
Setup Method	ANSI C63.4		
Tested Range	1 GHz to 24 GHz		
Test Voltage	48 VDC		
Modifications	No modifications were made to the unit		

NOTES: For emissions in restricted bands, the limit of 15.209 was used. For all other emissions, the limit was set 20dB below the level of the fundamental.

No Emissions were detected above 18 GHz

Restricted Band Peak Measurements: Resolution and Video BW: 1 MHz
 Restricted Band Average Measurements: Resolution BW: 1MHz and Video BW: 10 Hz.
 All other measurements, RBW = 1MHz and VBW = 3MHz, video averaging on (100 samples).

Results:

The table below presents a summary of the radiated emission in restricted bands for the low, middle and high channels for both 802.11 B and 802.11 G modes of operation. Plots follow the table.

Transmit Freq (MHz)	802.11 Mode	Emission Frequency (MHz)	Level dBmV/m	Pol V/H	15.209 / 15.247		Detector Pk/QP/Avg	Azimuth Deg	Height Meters
					Limit	Margin			
2412	B	7242.533	51.2	H	54.0	-2.8	AVG	249	1.5
2412	B	7242.533	51.7	H	74.0	-22.3	PK	249	1.5
2437	B	7308.555	44.1	V	54.0	-9.9	AVG	159	1.0
2437	B	7308.555	48.0	V	74.0	-26.0	PK	159	1.0
2437	B	7308.525	50.1	H	54.0	-3.9	AVG	221	1.1
2437	B	7308.525	53.8	H	74.0	-20.2	PK	221	1.1
2437	B	4880.000	36.5	V	54.0	-17.5	Peak	162	1.6
2437	B	9733.333	36.2	V	54.0	-17.8	Peak	165	1.3
2462	B	7407.500	47.6	H	54.0	-6.5	Peak	223	1.3
2462	B	9840.000	44.0	V	54.0	-10.0	Peak	173	1.3
2412	G	4842.500	35.2	H	54.0	-18.8	Peak	231	1.0
2412	G	7234.515	51.6	H	54.0	-2.4	AVG	218	1.0
2412	G	7234.515	68.9	H	74.0	-5.1	PK	218	1.0
2437	G	4880.000	30.5	H	54.0	-23.5	Peak	232	1.3
2437	G	7309.065	50.9	H	54.0	-3.1	AVG	222	1.1
2437	G	7309.065	70.5	H	74.0	-3.5	PK	222	1.1
2462	G	7384.730	53.4	H	54.0	-0.6	AVG	223	1.0
2462	G	7384.730	66.1	H	74.0	-7.9	PK	223	1.0

UUT Xmitting 802.11 B on low Channel: 2412 MHz

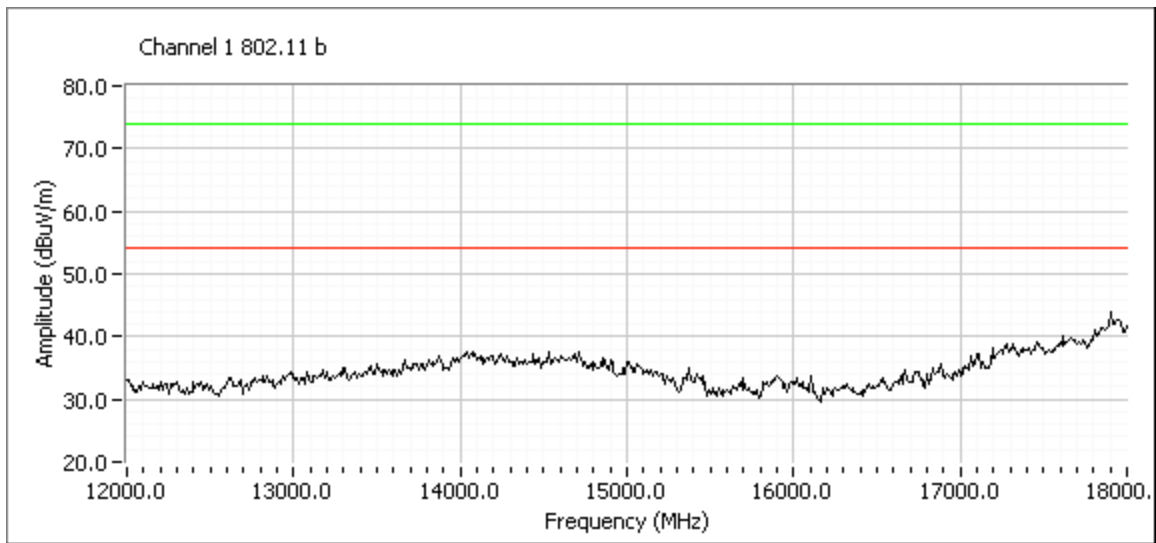
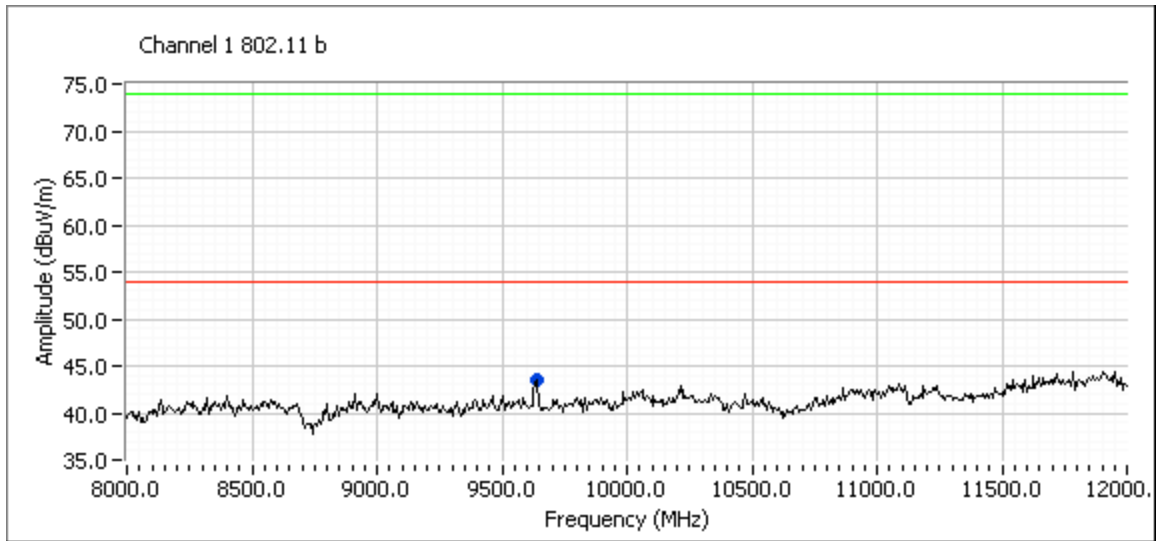
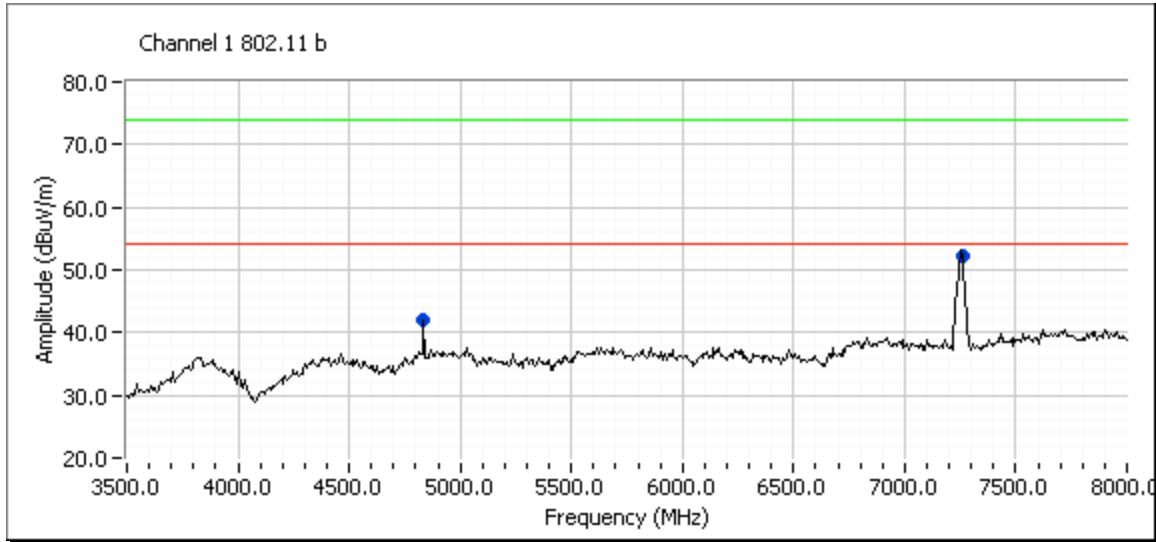

UUT Xmitting 802.11 B on mid Channel: 2437 MHz

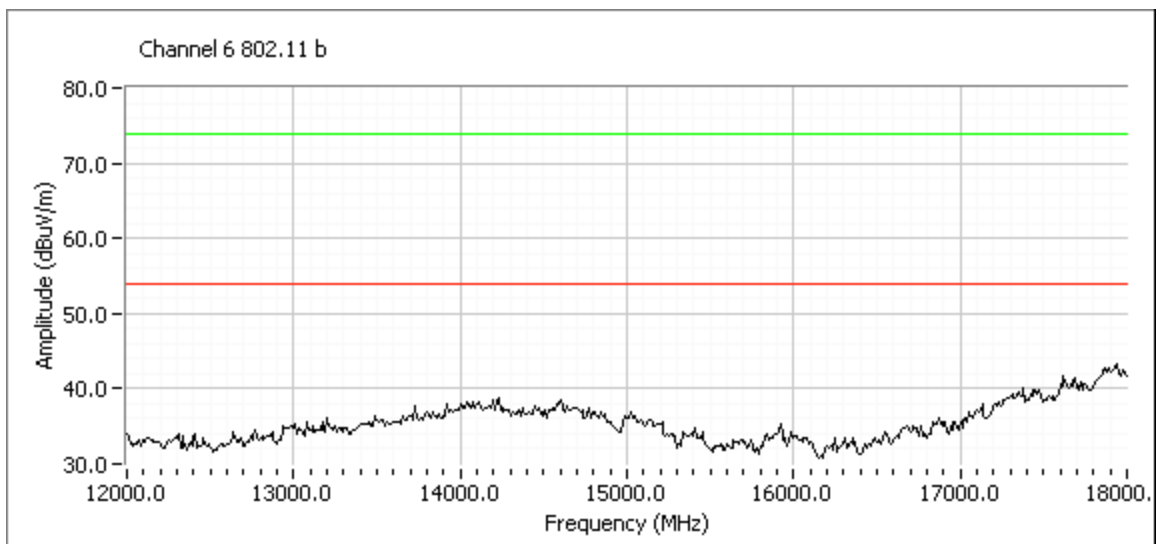
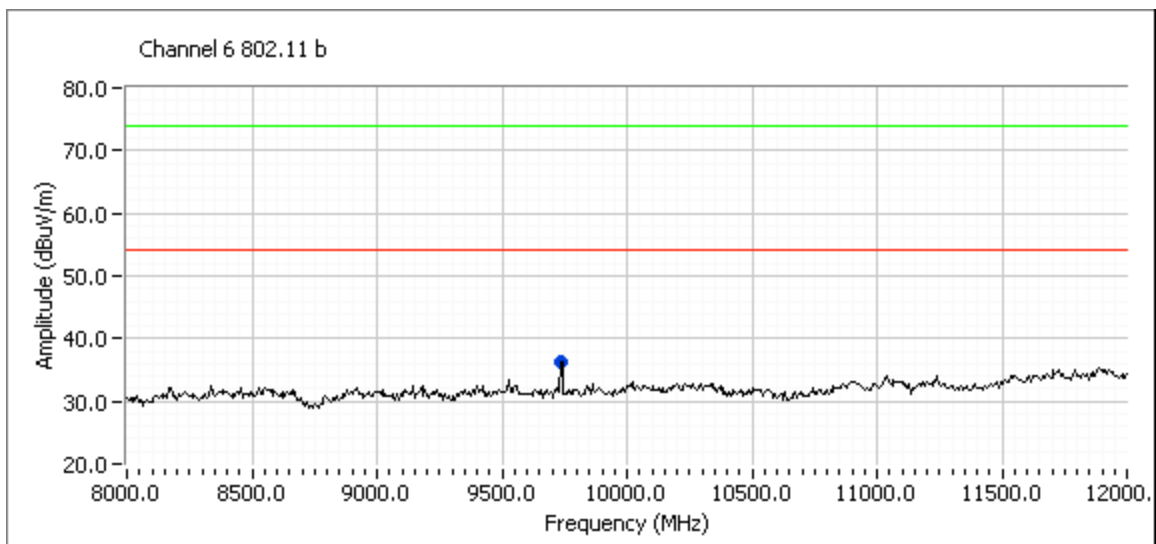
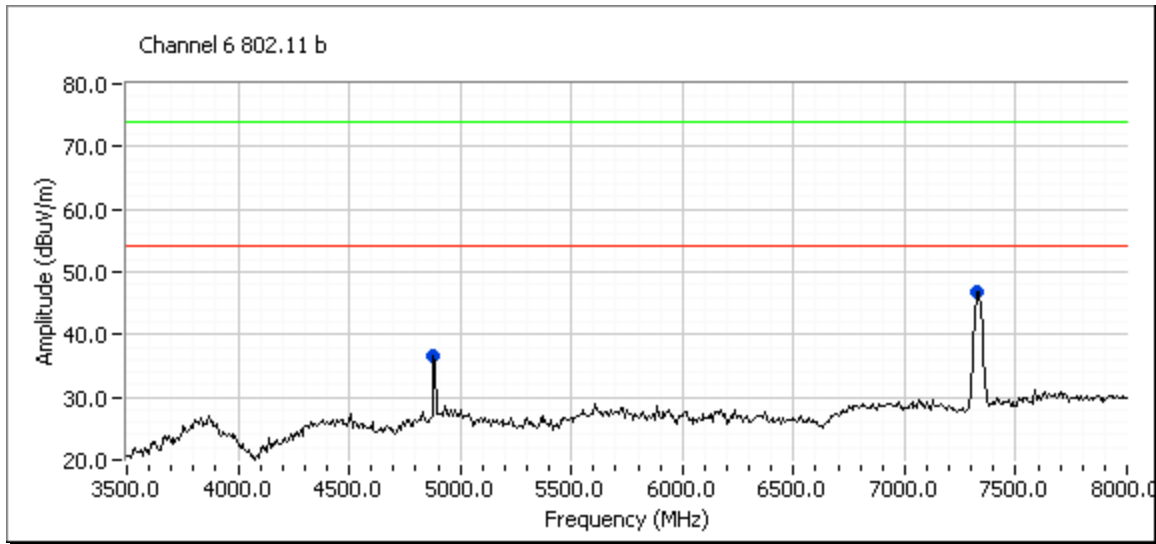

UUT Xmitting 802.11 B on high Channel: 2462 MHz

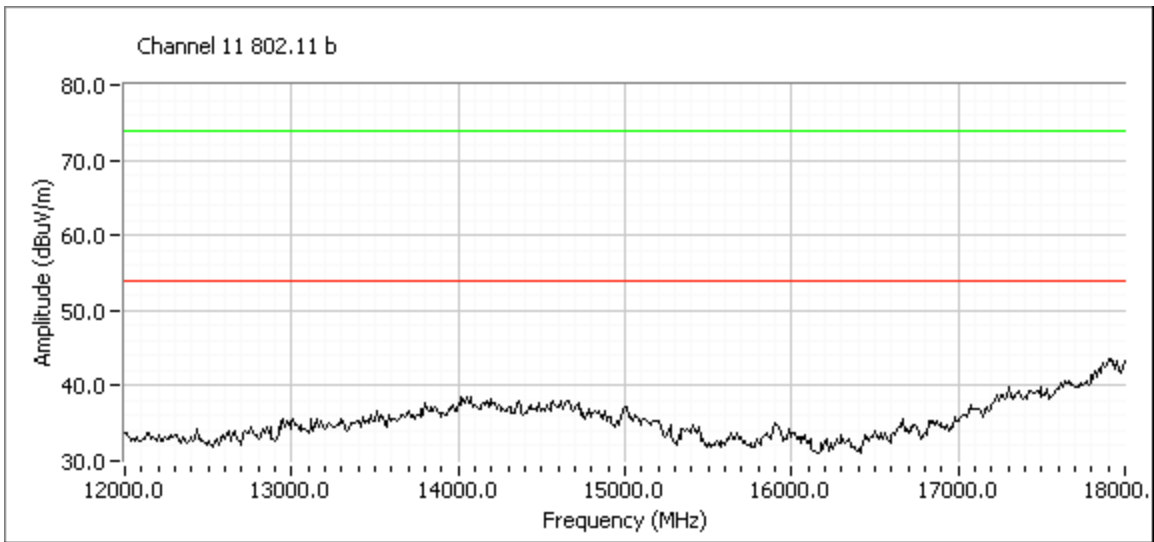
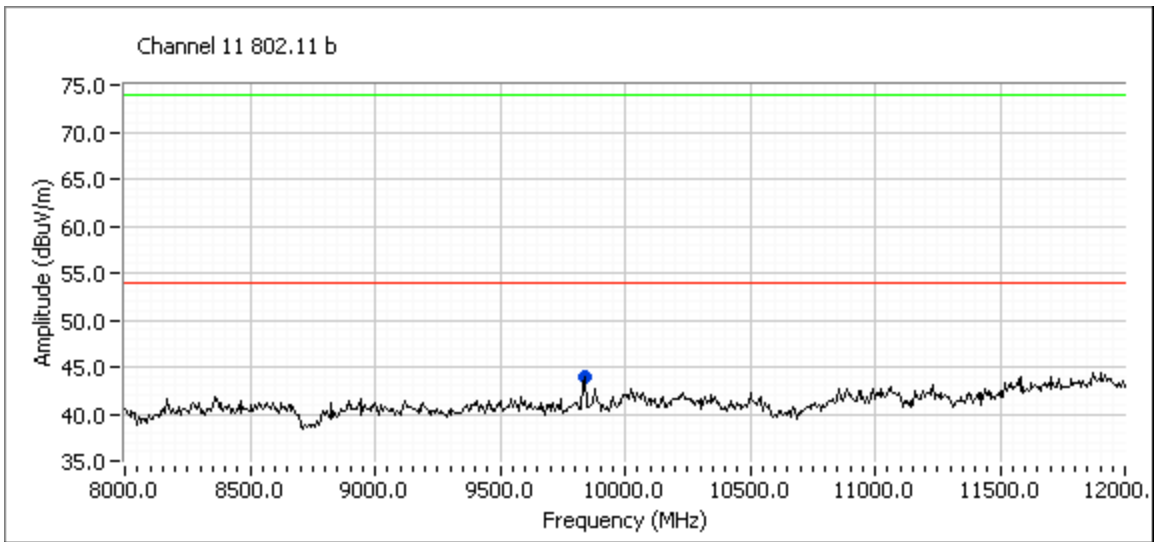
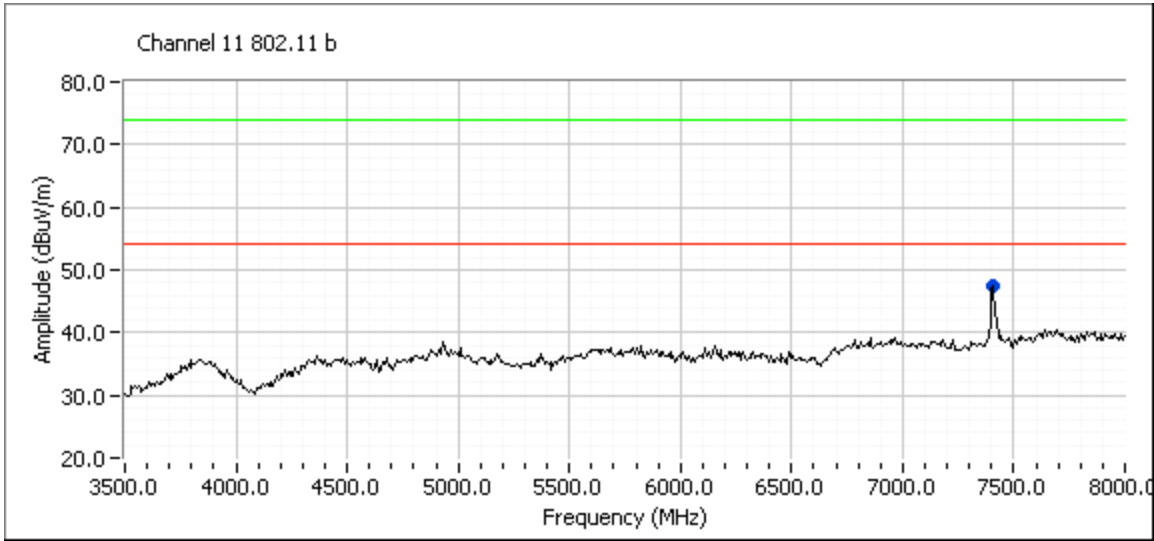

UUT Xmitting 802.11 G on low Channel: 2412 MHz

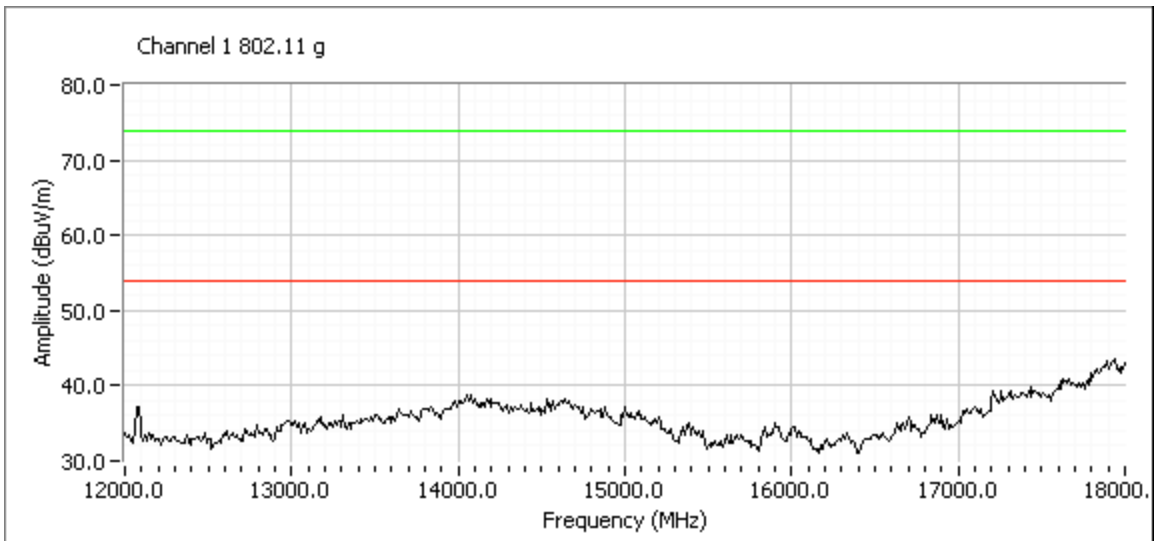
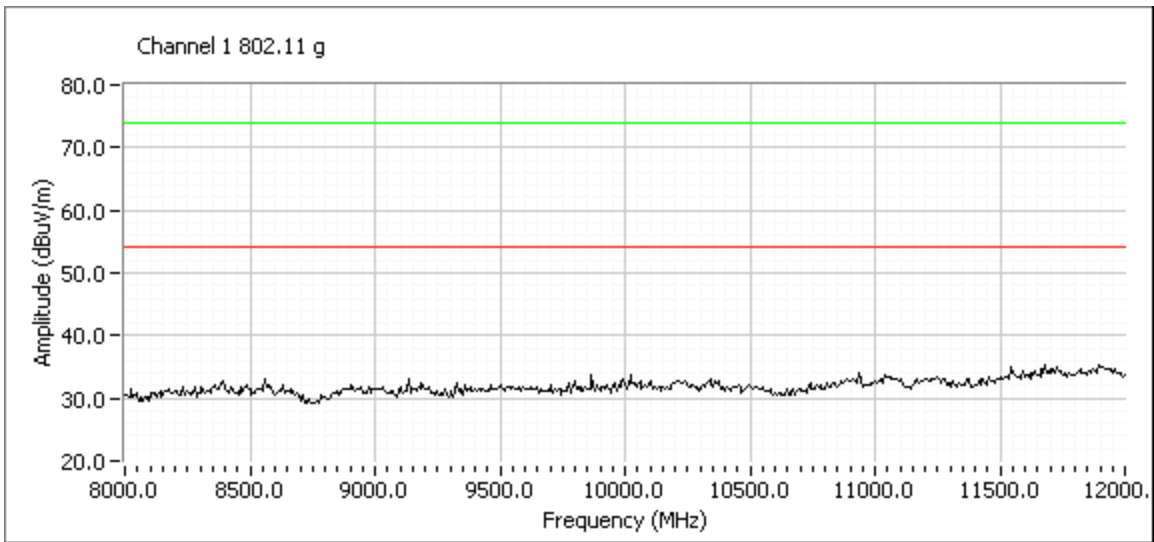
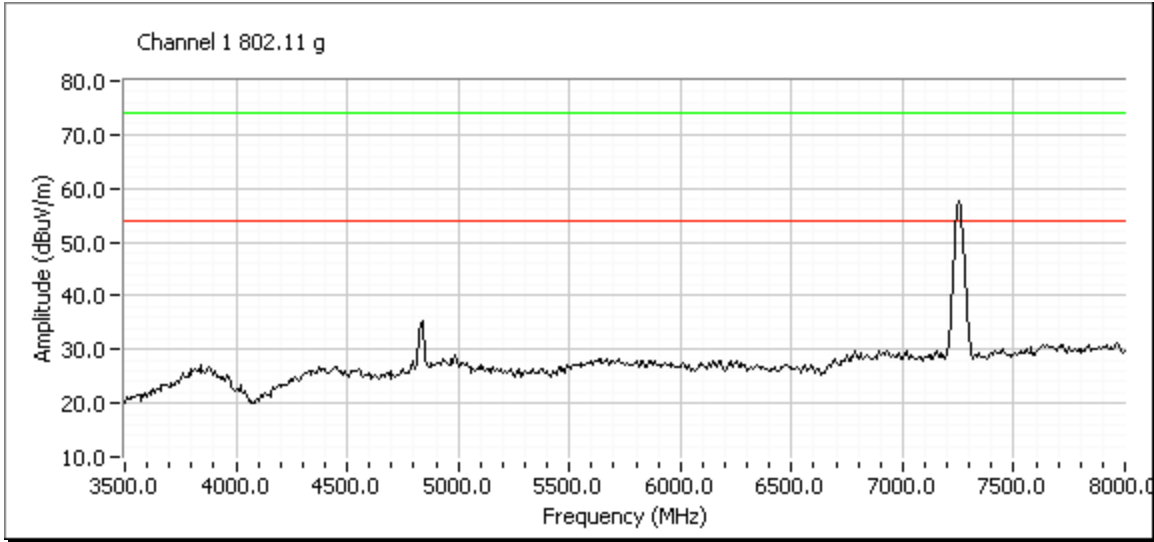

UUT Xmitting 802.11 G on mid Channel: 2437 MHz

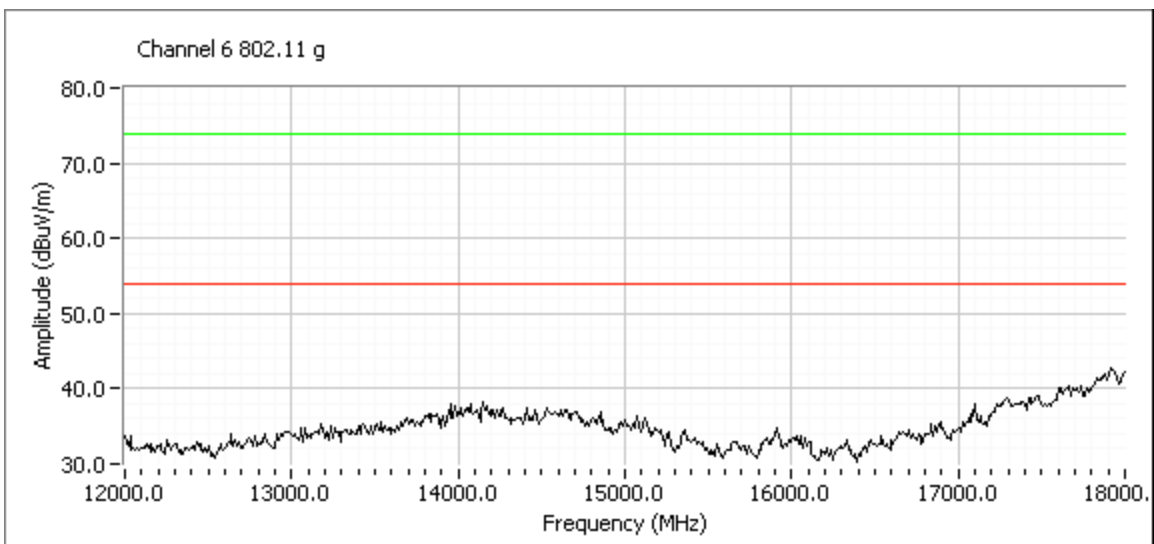
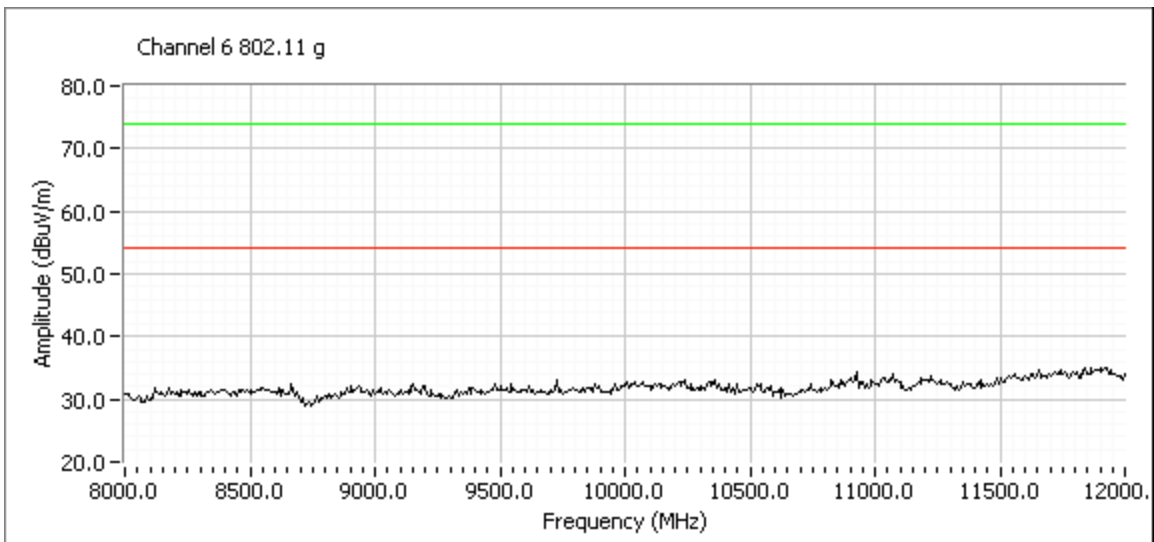
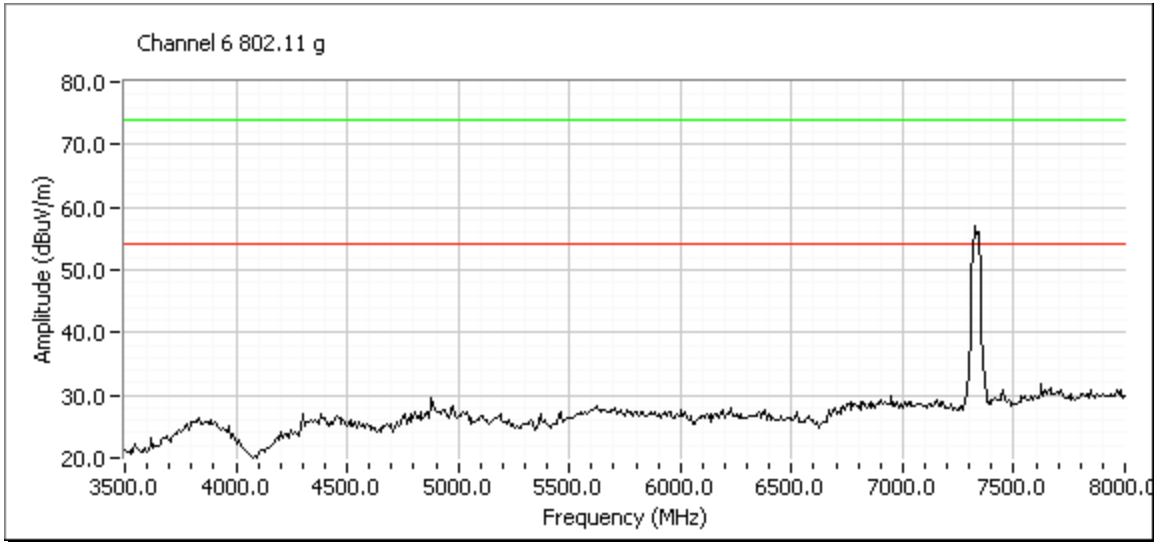

UUT Xmitting 802.11 G on high Channel: 2462 MHz

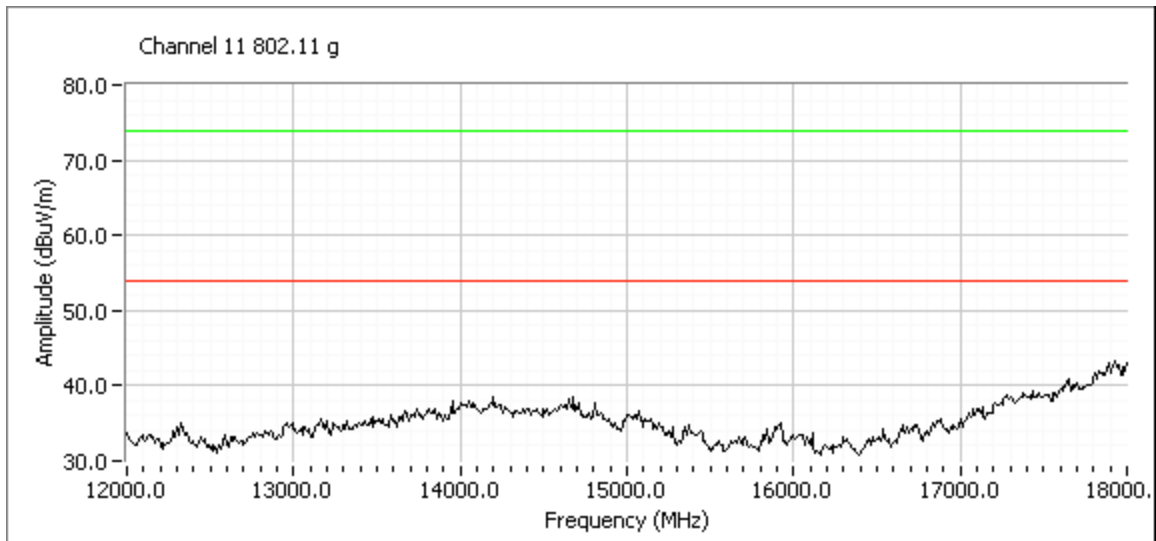
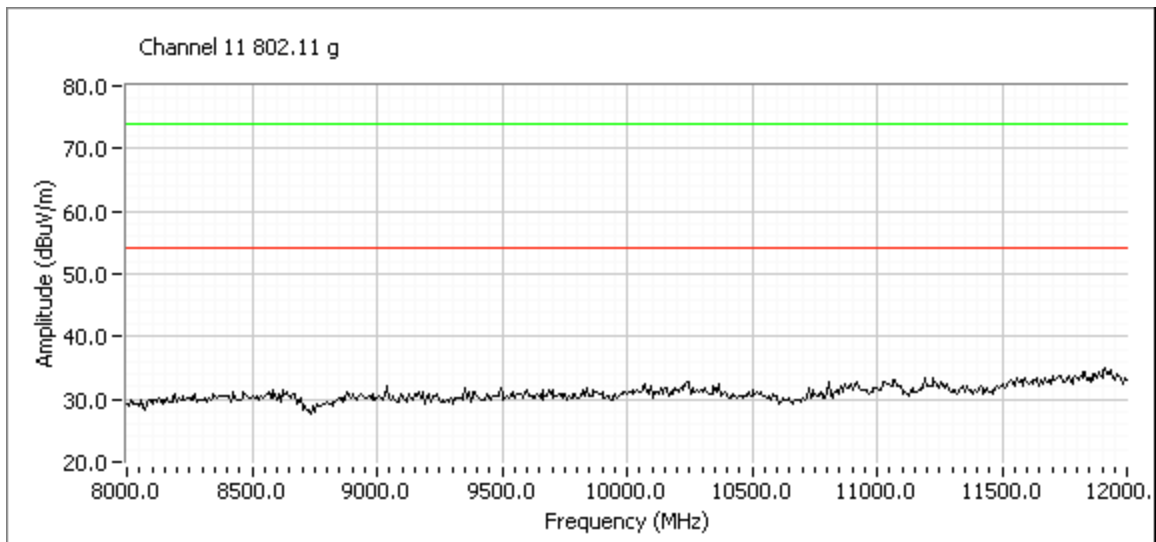
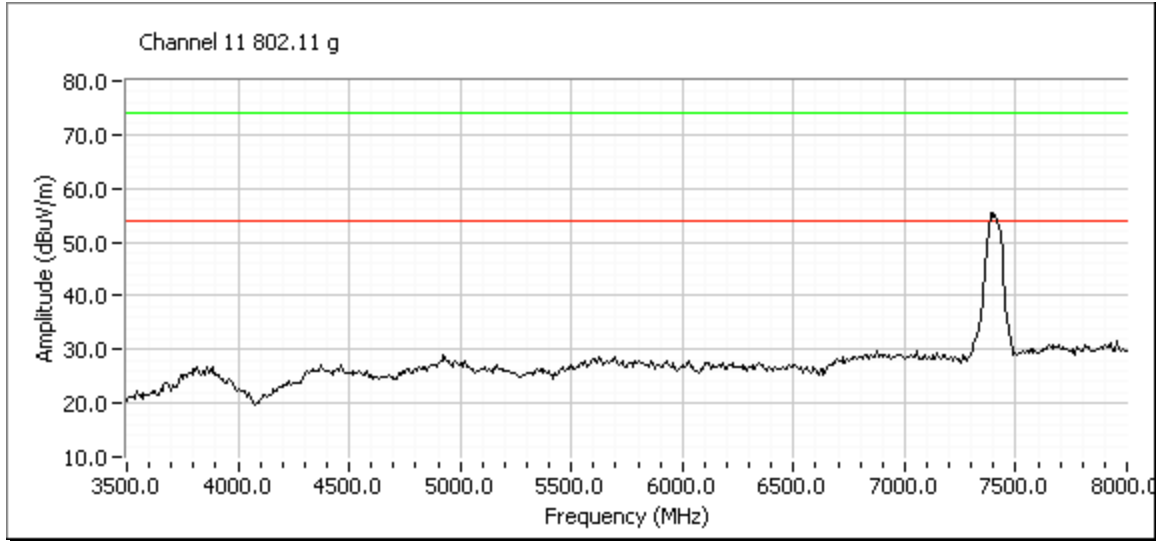

Radiated Emissions in Restricted bands (2.4 GHz Band Edges)

FCC Specifications: Paragraph 15.247(c)

Procedure:

Since this is a 2.4 GHz product, there is a restricted band that begins immediately at the high end of the operating band and another that begins 10 MHz below the low end of the operating band.



This test was conducted in a semi-anechoic chamber #5 4 at Elliott labs Fremont facility. There are three steps to performing this test.

STEP 1) The first involves making a radiated measurement of the fundamental signal with the UUT on the operating channel closest to the edge of the band. The unit was placed on a rotating wooden table 80cm above the OATS ground plane. A Horn antenna was secured to a mast 3 meters away. The test equipment was configured as shown below.

The EUT was rotated 360 degrees and the height of the antenna adjusted from 1 to 4 meters above the ground plane to determine the maximum level of the emission. The level of the fundamental emission was measured in two modes, “Peak” and “Average” using RBW and VBW of 1MHz/1MHz and 1MHz/10Hz respectively.

STEP 2) A second measurement (conducted) is made using to determine a Peak (RBW 1 MHz / VBW 1 MHz) and Avg (RBW 1 MHz / VBW 10 Hz) -dBc value. This value is measured from the peak of the “carrier” to the highest point within the restricted band.

STEP 3) A third and final measurement (conducted) is made to determine the apparent drop in signal level when the RBW is narrowed from 1MHz (in the reference measurement) to 100kHz (the bandwidth required for the restricted band emission measurement). This is referred to below as the “BW Delta”.

Peak Delta: RBW 1MHz VBW 1 MHz to RBW 100 kHz VBW 1 MHz

Avg Delta: RBW 1MHz VBW 10 Hz to RBW 100 kHz VBW 10 Hz

In some cases, this third measurement was not made if compliance was demonstrated without this measurement. In this case, if this measurement were made, it would only serve to increase the margin.

The level of the emission in the restricted band is then calculated using the following formulas.

$\text{Restricted band level (AVG)} = \text{AVG reference level} - \text{delta dB} - \text{BW Delta dB}$ $\text{Restricted band level (Peak)} = \text{Peak reference level} - \text{delta dB} - \text{BW Delta dB}$

Results Summary Table

802.11 B Band Edge (Restricted band @ 2.390GHz)												
Pol	Fundamental Radiated Ref Msmt		Delta Msmt		RBW Msmt		Radiated Level at Band Edge		Specification		Delta (dB below Limit)	
	Peak dbuv/m	Avg dbuv/m	Peak dBc	Avg dBc	Pk dB	Avg dB	Peak dBuv/m	Avg dBuv/m	Peak dBuv/m	Avg dBuv/m	Peak dBuv/m	Avg dBuv/m
Vert	109.5	106.7	48.7	53.6	0	0	60.78	53.09	74	54	13.22	0.91
Horz	96	92.6					47.28	38.99			26.72	15.01
802.11 B Band Edge (Restricted band @ 2.4835GHz)												
Pol	Fundamental Radiated Ref Msmt		Delta Msmt		RBW Msmt		Radiated Level at Band Edge		Specification		Delta (dB below Limit)	
	Peak dbuv/m	Avg dbuv/m	Peak dBc	Avg dBc	Pk dB	Avg dB	Peak dBuv/m	Avg dBuv/m	Peak dBuv/m	Avg dBuv/m	Peak dBuv/m	Avg dBuv/m
Vert	117.4	114.1	48.7	53.7	0	8.33	68.7	52.04	74	54	5.3	1.96
Horz	102.6	99.3					53.9	37.24			20.1	16.76
802.11 G Band Edge (Restricted band @ 2.390GHz)												
Pol	Fundamental Radiated Ref Msmt		Delta Msmt		RBW Msmt		Radiated Level at Band Edge		Specification		Delta (dB below Limit)	
	Peak dbuv/m	Avg dbuv/m	Peak dBc	Avg dBc	Pk dB	Avg dB	Peak dBuv/m	Avg dBuv/m	Peak dBuv/m	Avg dBuv/m	Peak dBuv/m	Avg dBuv/m
Vert	110.6	101.9	37.9	42.6	0	7.98	72.7	51.32	74	54	1.3	2.68
Horz	93.2	85					55.3	34.42			18.7	19.58
802.11 G Band Edge (Restricted band @ 2.4835GHz)												
Pol	Fundamental Radiated Ref Msmt		Delta Msmt		RBW Msmt		Radiated Level at Band Edge		Specification		Delta (dB below Limit)	
	Peak dbuv/m	Avg dbuv/m	Peak dBc	Avg dBc	Pk dB	Avg dB	Peak dBuv/m	Avg dBuv/m	Peak dBuv/m	Avg dBuv/m	Peak dBuv/m	Avg dBuv/m
Vert	102.2	92.1	32.2	38.3	0	8.07	70	45.73	74	54	4	8.27
Horz	97.7	88					65.5	41.63			8.5	12.37

NOTE: Zero entered for the RBW measurement indicates that the measurement was not made because it was not required in order to demonstrate compliance

Radiated emissions at band edge sample calculation (Vertical, Avg, 802.11 G, Low Edge):

$$\text{Emission Level} = \text{Fund Ref msmt} - \text{Delta msmt} - \text{RBW Delta msmt}$$

Example: 106.7 dBuV/m – 53.6 dBc – 0dB = 53.09dBuv/m
 54 dBuv/m - 53.09dBuv/m = .91 dB margin

Agilent 07:52:58 May 10, 2004

Mkr1 -24.8 MHz
-48.72 dB

802.11 B
-dBc Msmt @ 2390
Peak

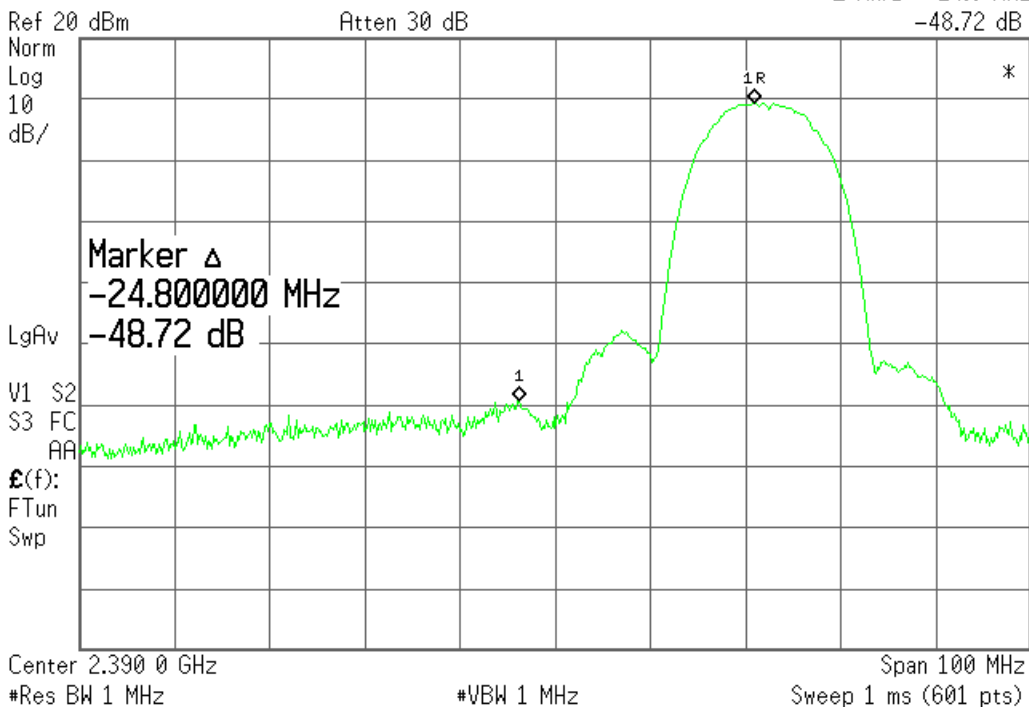

Agilent 07:56:58 May 10, 2004

Mkr1 -24.7 MHz
-53.61 dB

802.11 B
-dBc Msmt @ 2390
Avg

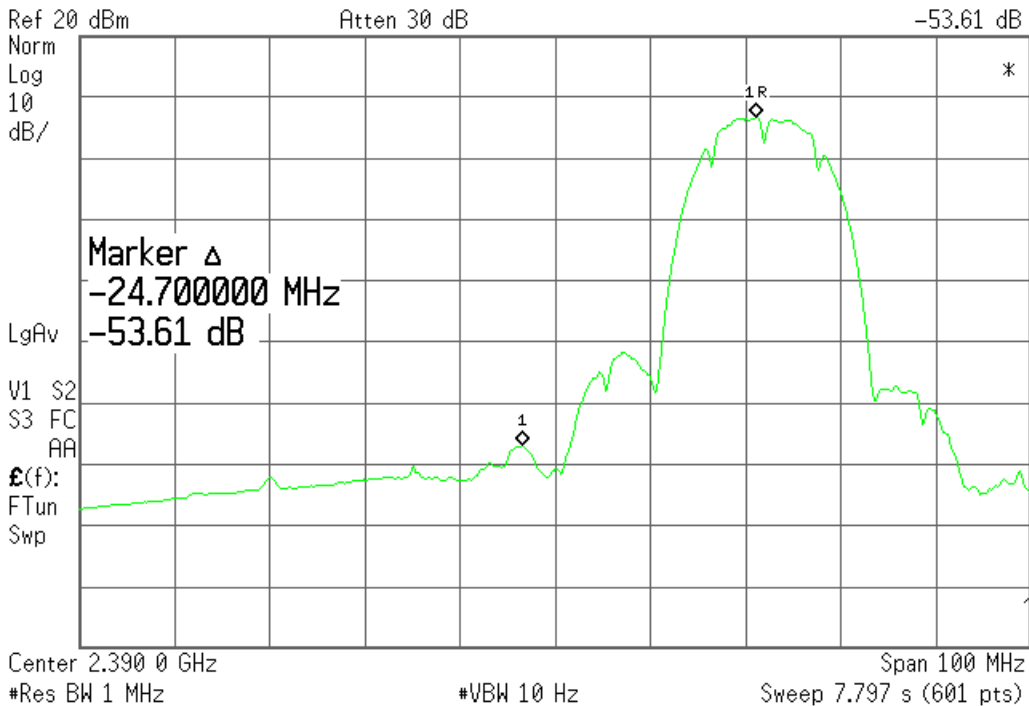

Agilent 07:18:37 May 10, 2004

802.11 G
-dBc Msmt @ 2390
Peak

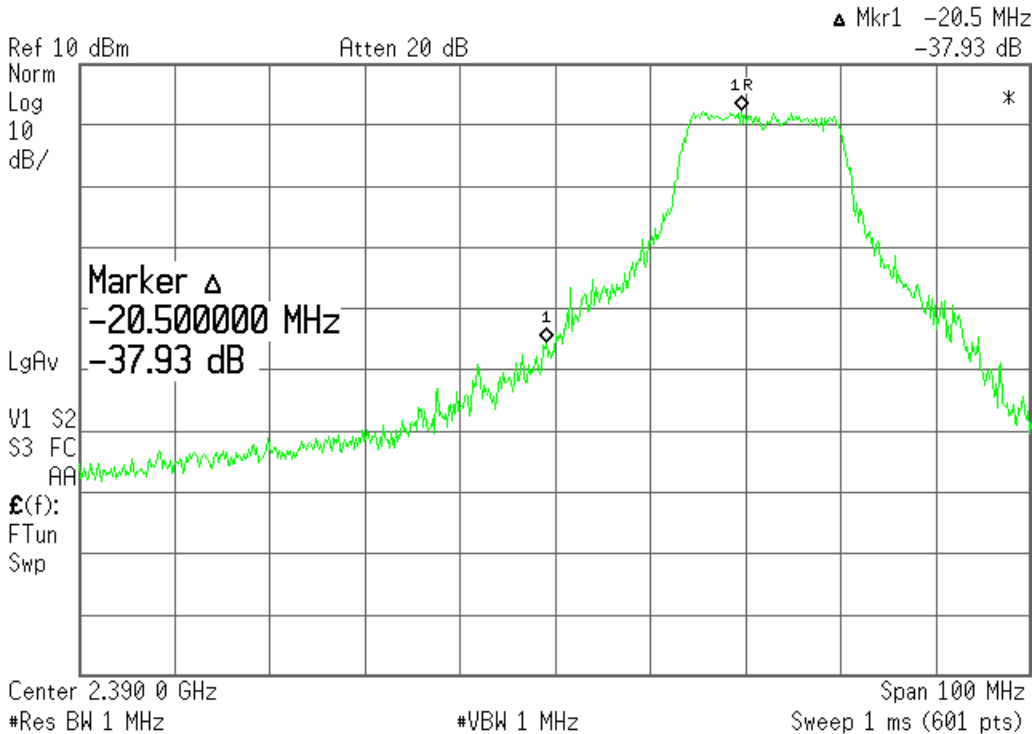

Agilent 07:20:13 May 10, 2004

802.11 G
-dBc Msmt @ 2390
Avg

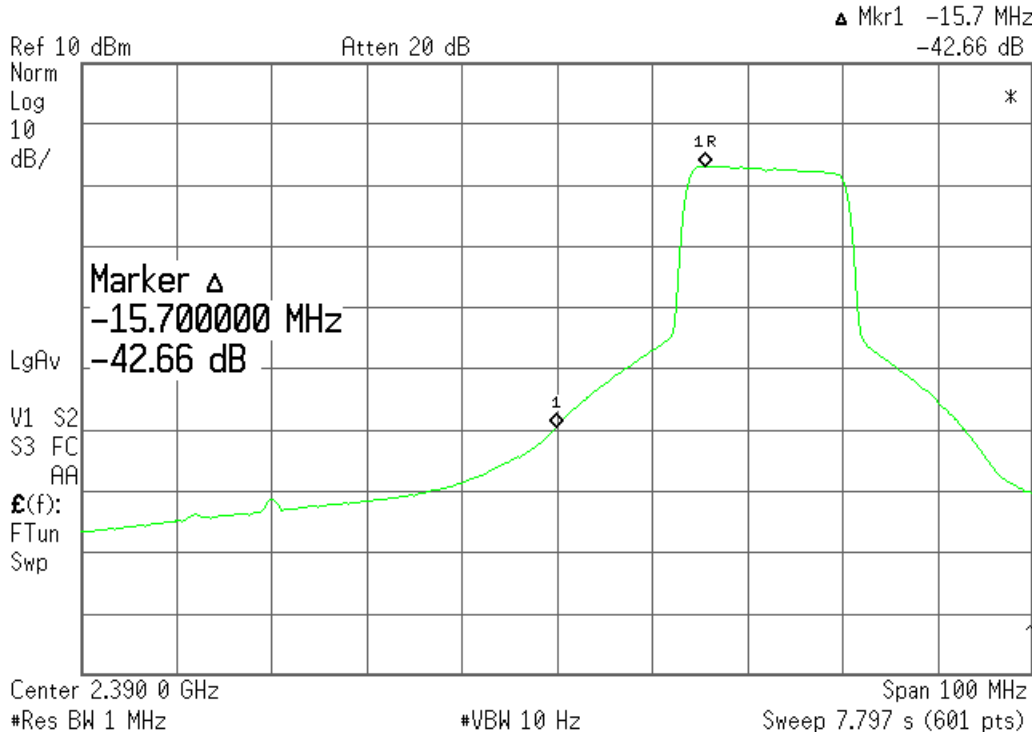

Agilent 07:25:25 May 10, 2004

Mkr1 0 Hz
7.98 dB

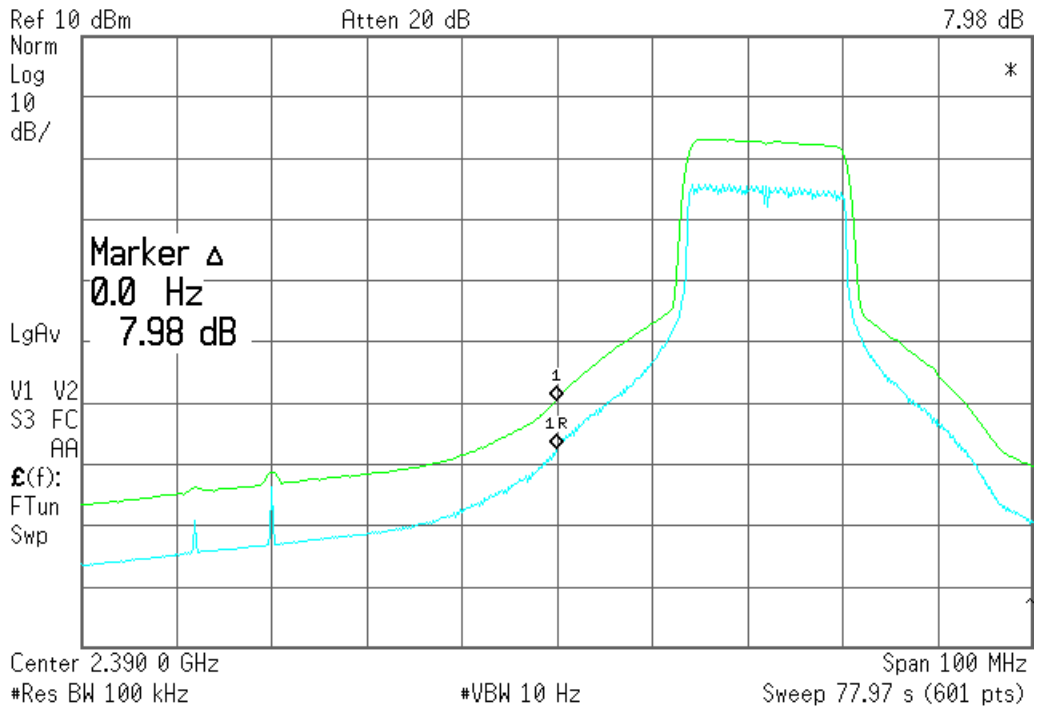

Agilent 08:02:35 May 10, 2004

Mkr1 21.7 MHz
-48.77 dB

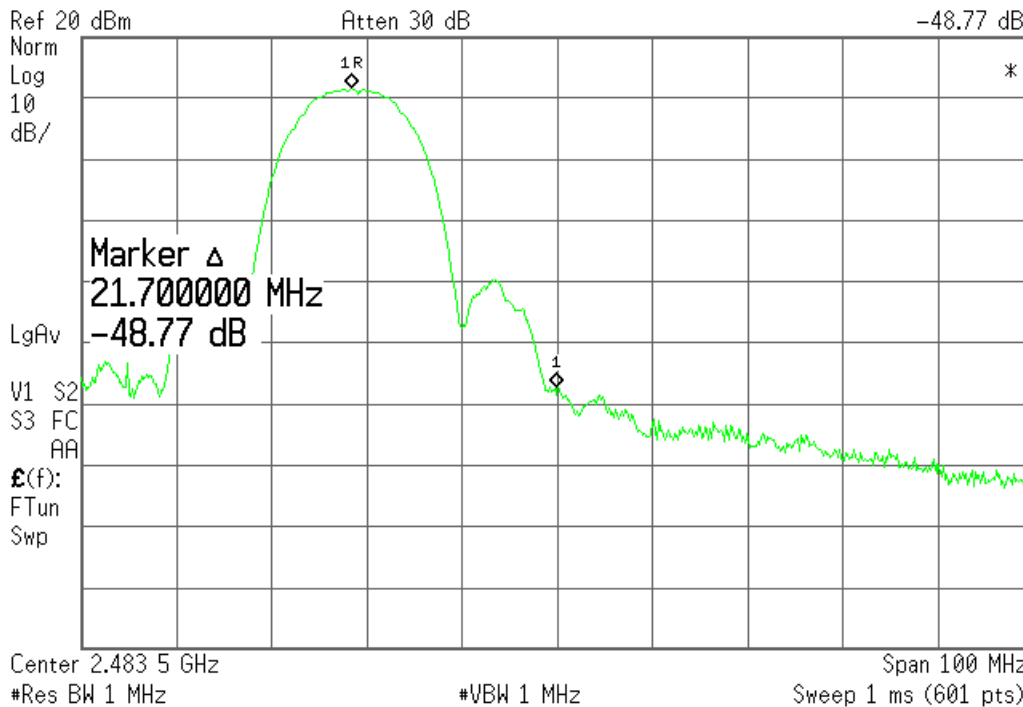

802.11 B
-dBc Msmt @
2483.5 Peak

Agilent 08:07:52 May 10, 2004

Mkr1 22.5 MHz
-53.73 dB

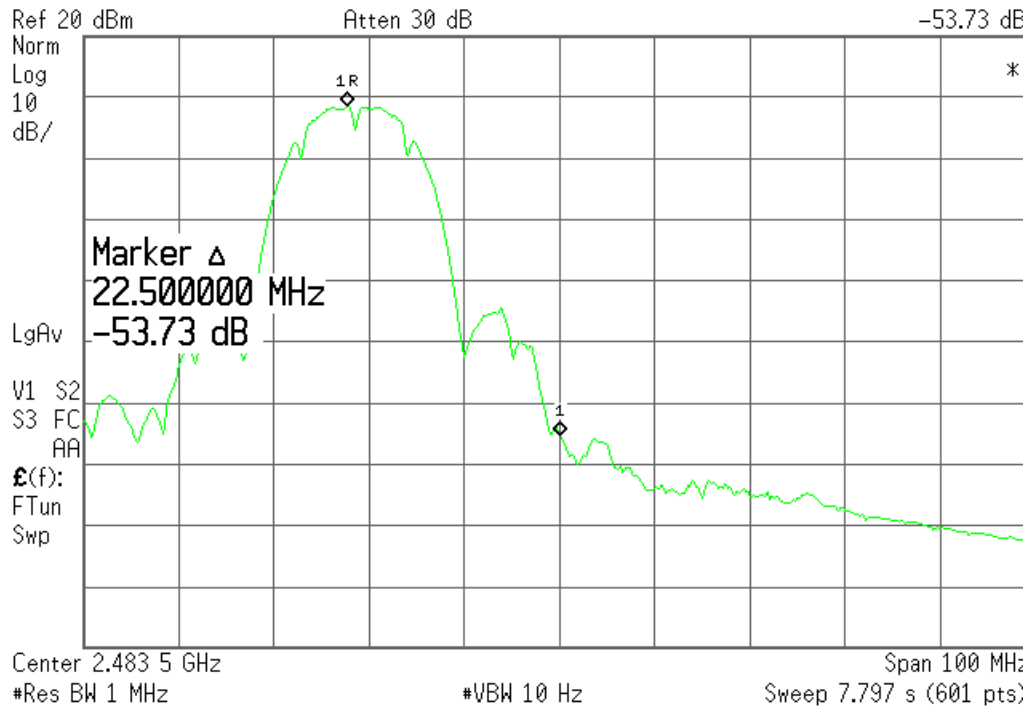

802.11 B
-dBc Msmt @
2483.5 Avg

Agilent 08:18:36 May 10, 2004

Mkr1 0 Hz
8.33 dB

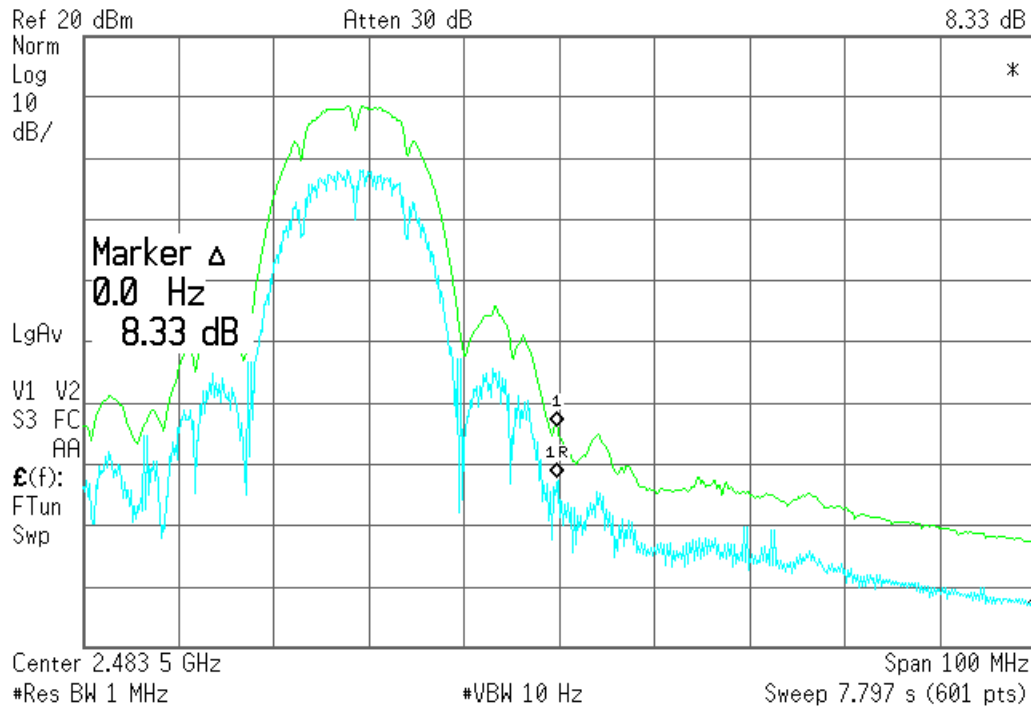

Agilent 08:33:45 May 10, 2004

Mkr1 14.5 MHz
-32.20 dB

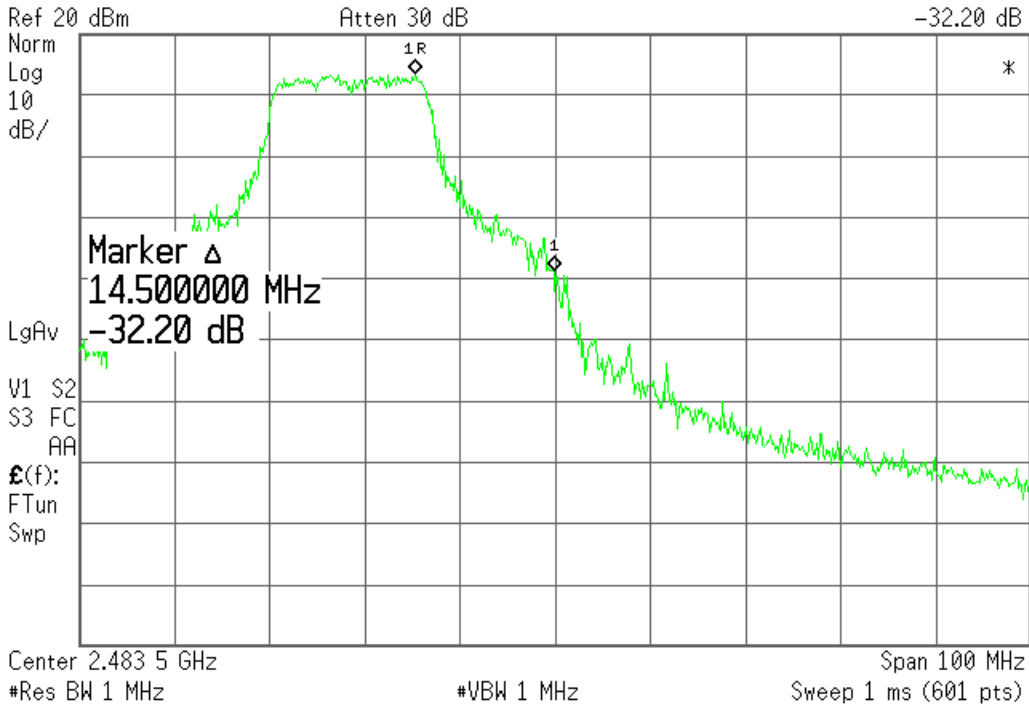

802.11 G
-dBc Msmt @
2483.5 Peak

Agilent 08:35:57 May 10, 2004

Mkr1 19.0 MHz
-38.30 dB

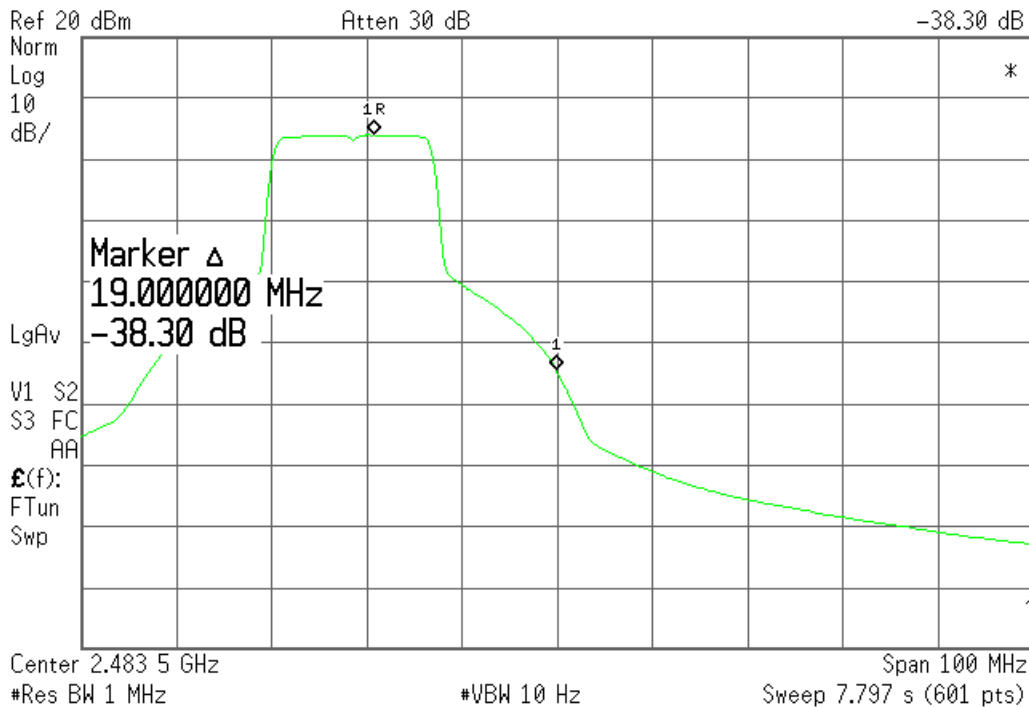

802.11 G
-dBc Msmt @
2483.5 Avg

Agilent 08:40:12 May 10, 2004

Mkr1 0 Hz
8.07 dB

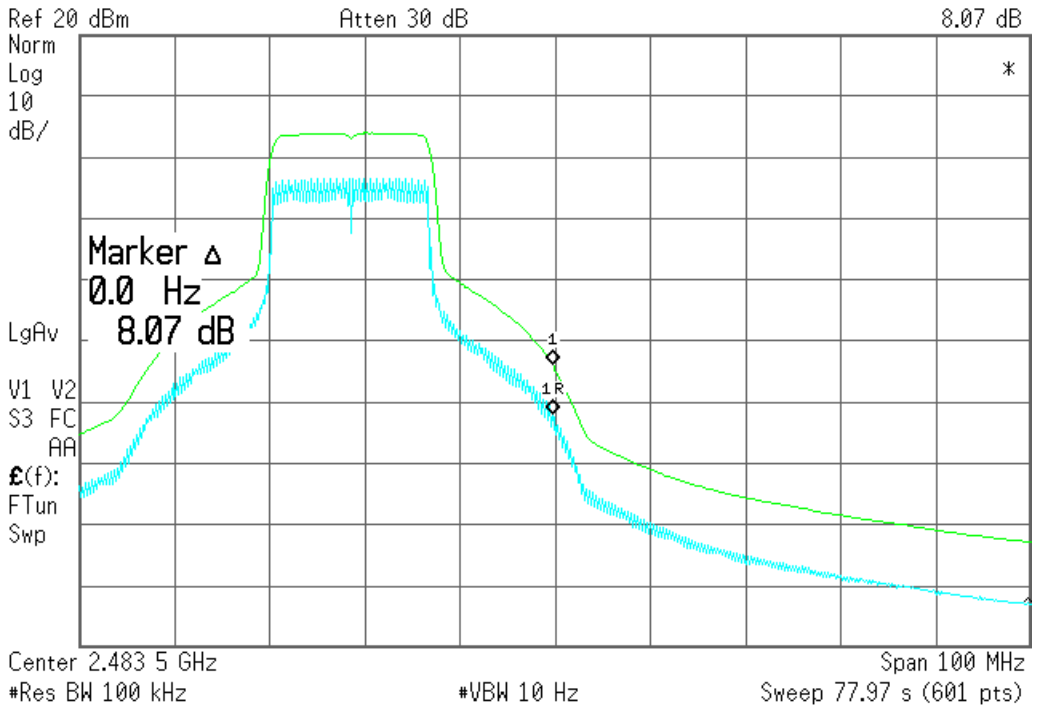

AC Line Conducted Emissions

Specification:

Specification: CISPR 22

Procedure:

The test was set up according to the guidelines set forth in EN55022:1998 and FCC Part 2 for AC Line Conducted Emissions. The measurement used a LISN line on each AC line and an EMI receiver. A peak scan was made over the measurement frequency range (150 kHz to 30 MHz). The highest peaks were then marked and re-measured and quasi-peaked and averaged.

The test was configured as shown below. The product was tested with "power injector" running on 120 VAC @ 60 Hz. The power injector provides -48VDC onto an Ethernet cable to power the access point.

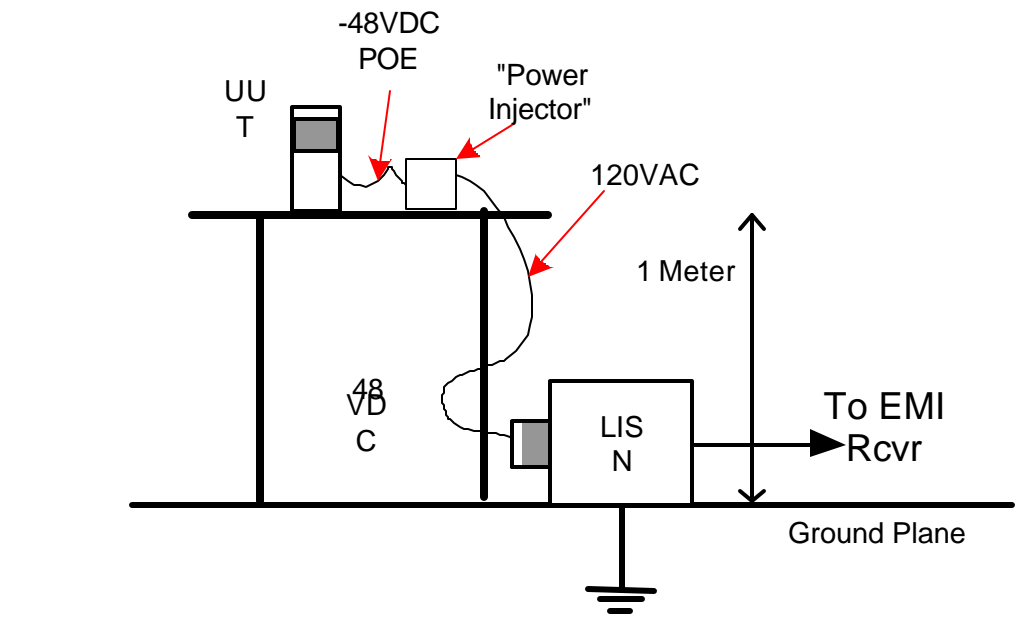

Results:

The “Quasi-peak” and the AVG results for the unit transmitting packets are contained in the table below

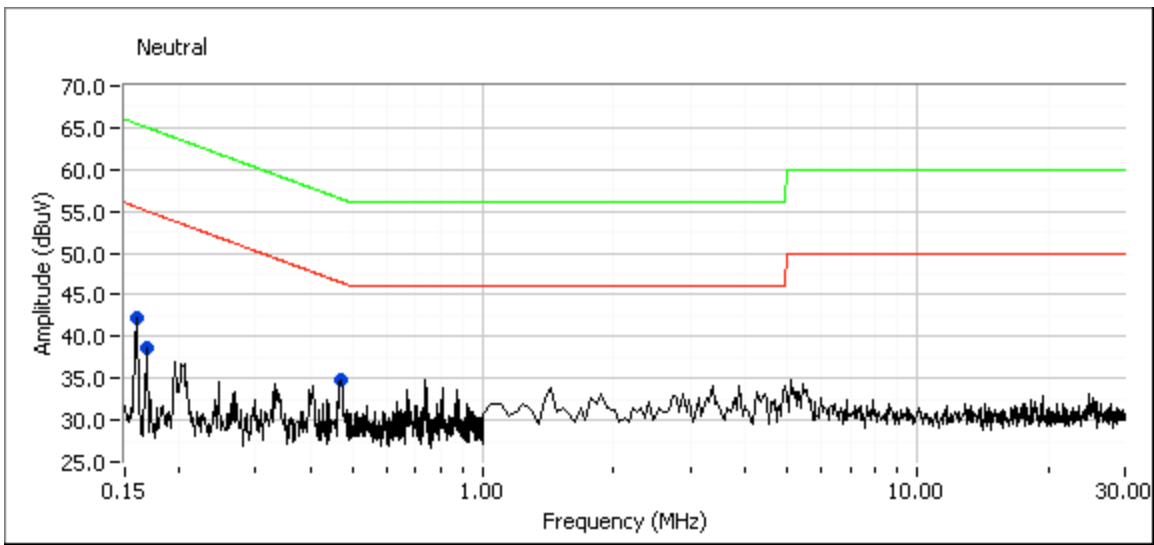
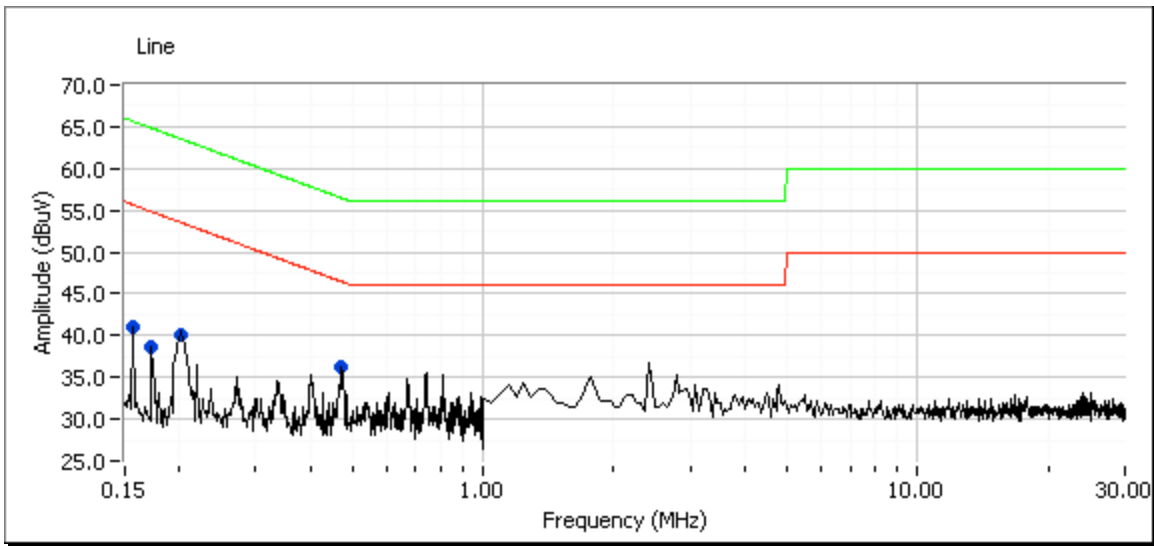

Frequency MHz	Level dBµV	AC Line	EN55022 Class B		Detector QP/Ave
			Limit	Margin	
Preliminary peak readings captured during pre-scan (peak readings vs. average limit)					
0.470	36.4	Line 1	46.5	-10.1	Peak
0.473	34.9	Neutral	46.5	-11.6	Peak
0.160	42.4	Neutral	55.5	-13.1	Peak
0.201	40.0	Line 1	53.6	-13.6	Peak
0.156	41.0	Line 1	55.6	-14.6	Peak
0.172	38.7	Line 1	54.8	-16.2	Peak
0.168	38.7	Neutral	55.0	-16.4	Peak

Receiver Spurious Radiated Emissions

Specification:

Specification: 15.109(f)

Procedure:

The test was configured as a standard EN55022 Class B radiated emissions test setup. Emissions were measured on the entire access point, not only the receiver. The access point was not transmitting at the time. The frequency range of 30 to 1000 MHz was scanned. The Radiated emissions in restricted bands data demonstrate compliance with this section above 1000MHz.

Results:

The detected emissions are presented in the tables below.

Vertical Polarization

No.	Frequency	Factor	Reading	Emission	Limit	Margin	Tower / Table	
	MHz						dB	dBuV
1	75.43	11.3	18.6	29.8	40.0	-10.2	100	22
2	128.93	12.4	26.2	38.6	43.5	-4.9	100	270
* 3	151.24	13.8	26.5	40.3	43.5	-3.2	100	262
4	250.02	13.2	14.0	27.2	46.0	-18.8	100	279
5	300.00	15.2	16.0	31.3	46.0	-14.7	100	312
6	360.00	16.9	12.7	29.6	46.0	-16.4	100	55
7	375.00	17.4	16.2	33.6	46.0	-12.4	100	86
8	399.96	18.1	13.1	31.2	46.0	-14.8	100	309
9	480.00	20.3	12.6	33.0	46.0	-13.0	100	316
10	560.00	22.0	10.0	32.0	46.0	-14.0	119	78
11	624.99	23.5	9.5	33.0	46.0	-13.0	153	333
12	720.00	24.8	8.3	33.2	46.0	-12.8	208	23
13	750.02	25.3	11.7	37.0	46.0	-9.0	137	256
14	880.00	27.6	9.8	37.3	46.0	-8.7	199	337

Horizontal Polarization

No.	Frequency	Factor	Reading	Emission	Limit	Margin	Tower / Table	
	MHz						dB	dBuV
1	128.47	12.4	20.9	33.2	43.5	-10.3	237	87
2	151.01	13.8	21.9	35.7	43.5	-7.8	237	277
3	250.00	13.2	14.1	27.3	46.0	-18.7	246	144
4	375.00	17.4	14.7	32.1	46.0	-13.9	232	333
5	399.98	18.1	11.4	29.5	46.0	-16.5	207	125
6	479.99	20.3	8.8	29.1	46.0	-16.9	233	304
7	639.98	23.8	9.2	33.0	46.0	-13.0	189	119
8	719.98	24.8	13.3	38.1	46.0	-7.9	127	214
9	759.98	25.5	13.1	38.6	46.0	-7.4	100	218
* 10	879.99	27.6	11.5	39.0	46.0	-7.0	180	245