

Prepared: Peter Ku		
Issued Date:		
Title PRS-201WU		
Size B	Document Number Memory	Rev 0A2
Date: Monday, January 20, 2003		Sheet 2 of 5

- (1,2,5) AD[0..15]
- (1) A[1..18]
- (1) /WR
- (1) /RD
- (1) /CS_USB
- (1) INT2

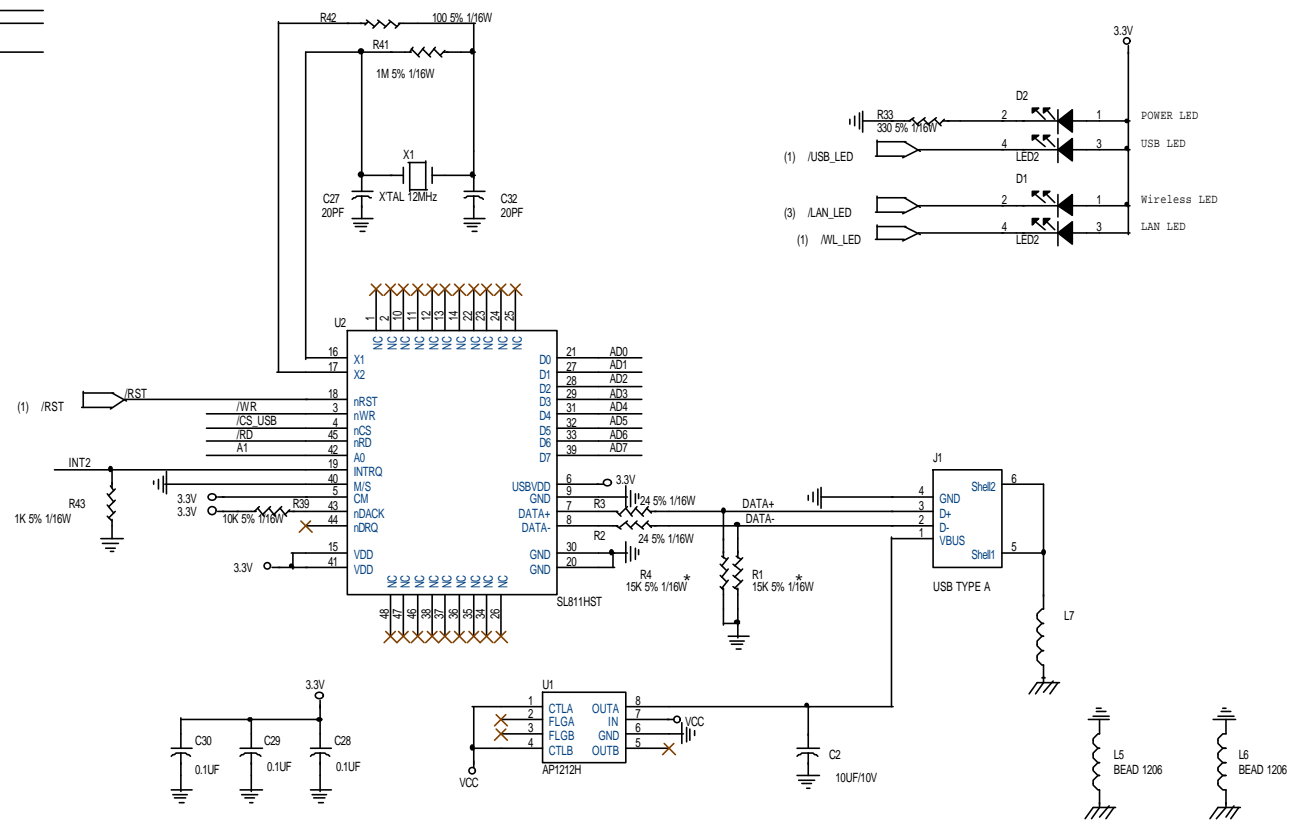

Title		
<Title>		
Size	Document Number	Rev
B	<Doc>	0A2
Date:	Monday, January 20, 2003	Sheet 4 of 5

(1) A[0..18]

(1,2,4) AD[0..15]

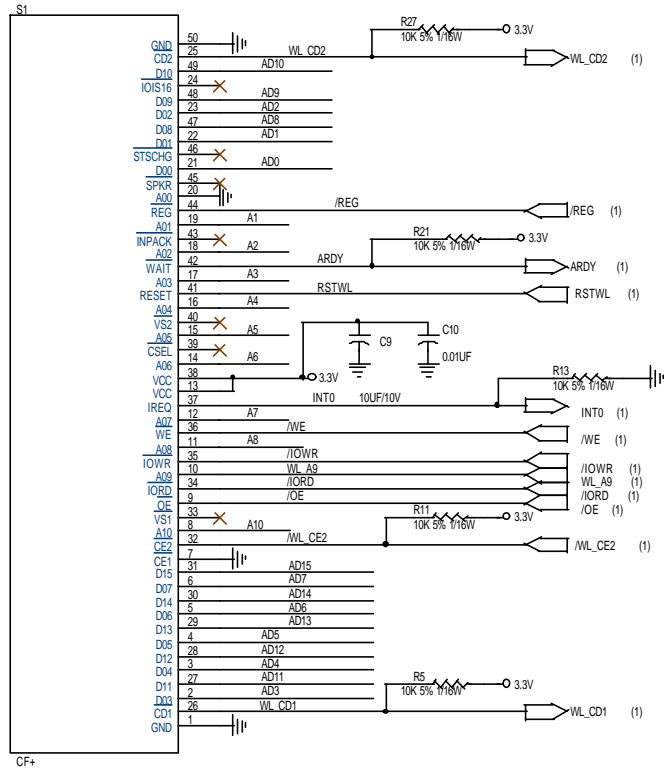
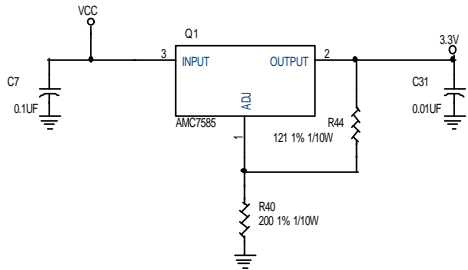
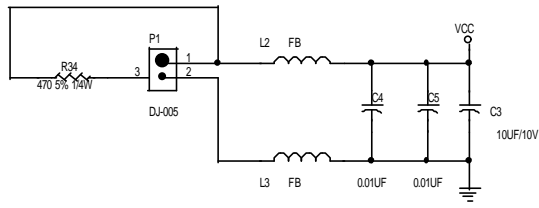
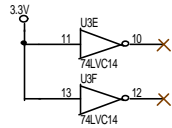

Prepared : Peter Ku	
Issued Date :	
Title PRS-201WU	
Size B	Document Number Wireless & power
Date: Monday, January 20, 2003	Rev 0A2
Sheet 5 of 5	