



Basic 7in and 9in
Bluetooth Keyboard

DRAFT

Revision History

Revision	Date	Notes	Released By
01	05/04/2014	Initial Release	Owen Carlson



Table of Contents

- 1. General Specification..... 6
- 2. Mechanical Specification 8
 - 2.1. Characteristics of Material..... 8
 - 2.2. Packed – Including Packaging..... 8
 - 2.3. Detachability of Cable Pull Out 9
 - 2.4. Key module configuration..... 9
 - 2.5. Key Board Specification 10
 - 2.6. Life Test..... 10
 - 2.7. Specification of Rubber Switch 10
 - 2.8. Max Keycap Depressing Force..... 11
 - 2.9. Keyboard Height..... 11
 - 2.10. Keycap Strength 11
 - 2.11. Keycap Spacing and Alignment..... 11
 - 2.12. Key in Test Spec On The 4 Corners Of The Key Cap..... 12
 - 2.13. Characteristics of Switches 12
 - 2.14. Slide Switch 12
 - 2.15. Tact Switch 13
 - 2.16. Sleep Magnet Function 13
 - 2.17. Snap force and life test..... 13
- 3. Electrical Specification..... 13
 - 3.1. Electrical Characteristics 13
 - 3.2. Feature:..... 13
 - 3.3. Power Rating 14
 - 3.4. LED Indicator behavior..... 14
 - 3.5. RF Specifications..... 15



3.6. Bluetooth Module Block Diagram	17
3.7. Sleep mode	17
3.8. Keyboard layout	18
3.9. 7 Inch Key frame.....	18
3.10. Fn Combination Key Function Descriptions	18
3.10.1. 7in Non backlight Alcatel Android 5.0 US.....	Error! Bookmark not defined.
3.10.2. 7in Non backlite LG E8 Android 5.0 US	Error! Bookmark not defined.
3.11. Bluetooth 3.0 9 inch Keyboard Key Matrix for Apple.....	18
3.12. Schematic Circuit.....	19
3.13. Pseudo N-Key Rollover Capability	20
3.14. Free From Illegal Ghost key	20
3.15. Compatibility	20
3.16. Charging Specification.....	20
3.17. Keyboard Module.....	20
3.18. Key Functional Test	20
3.19. Bluetooth RF Power & Frequency Test	20
3.20. EMI Test	20
3.21. ESD TEST	21
3.22. EFT Test	21
4. Environmental and Reliability Specifications.....	21
4.1. Acoustic Noise	21
4.2. Temperature and Humidity Test	22
4.3. Heat Treatment Impact Test	22



4.4. Vibration Test	23
4.5. Bare Unit Drop Test	24
4.6. Packaged Box Drop Test	24
4.7. Life Test	25
4.8. UV Test	25
4.9. Spillage Test	26
4.10. Endurance Test	27
4.11. Physical / Software compatibility check	28
4.12. PLP – Product Liability Program	28
4.13. Abrasion Test – Legend (1X key silk-screen printing)	28
4.14. Abrasion Test - Logo/ Icon	29
4.15. Abrasion Test – Painting (Outlook parts printing)	29
4.16. Chemical Resistance Test	29
4.17. Adhesion Test	29
4.18. Keycap Texture Endurance Test	30
4.19. Compression Test-Type 1A	30
4.20. Corrugated Box (Carton) Compression Test	30
4.21. Compliance	30
4.22. Safety Standard	31
4.23. Environment Specification Items	31
4.24. Appearance Specification	32



- 5. Patent 32
- 6. View Angle 32
 - 6.1. Angle Specifications..... 32
- 7. Keyboard Layout for different Languages 33
 - 7.1. 7in Non backlight Alcatel Android 5.0 US **Error! Bookmark not defined.**
 - 7.2. 7in Non backlite LG E8 Android 5.0 US **Error! Bookmark not defined.**
- 8. Cable..... 33
 - 8.1. Micro USB Charge Cable 33

DRAFT

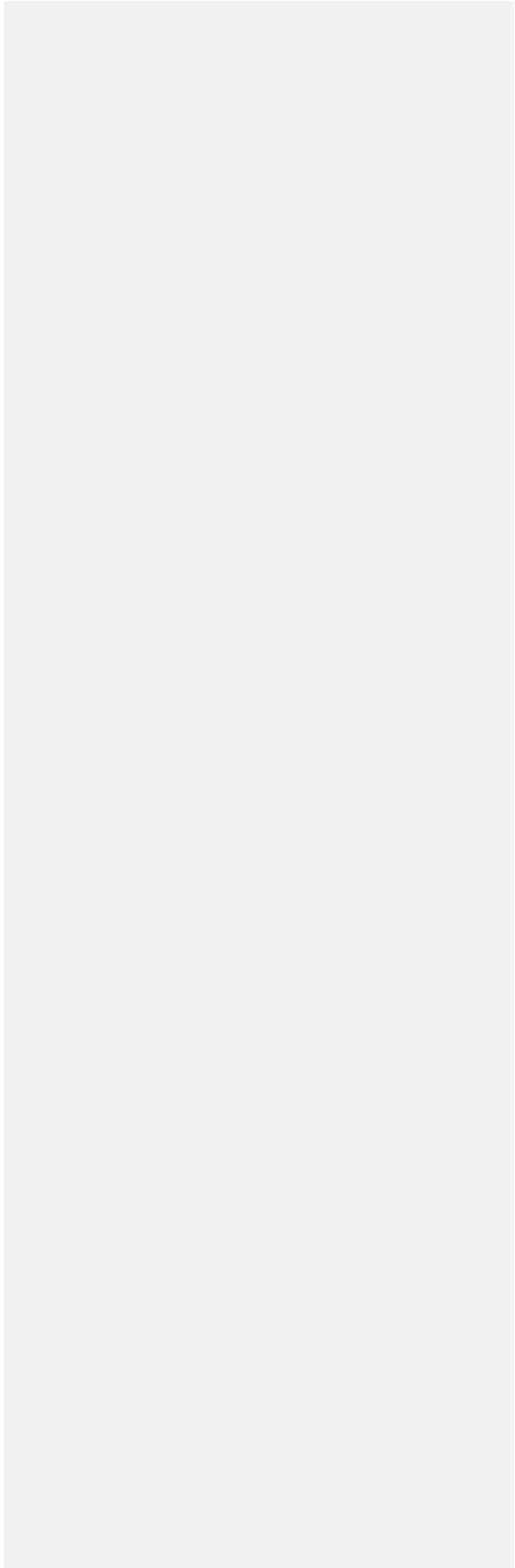



1. General Specification

This specification is applied to the Bluetooth wireless keyboard folio for Windows iPad series.

General Product Information	
Product Type	ZAGG Folio Keyboard
Connection Type	Bluetooth Wireless
Keypad Features	Slim
Wireless Protocol	Bluetooth 3.0
Wireless Range	10M
Software Support (at release)	As needed per device
OS Support (at release)	As needed per device
Indicator Lights (LED)	Under Caps Lock, Under Power (for Pairing too)
Backlight	None
Battery Details	450mAh, 3.7V
Battery Life	365 days one hour per day use
Power Charge	Micro USB cable (TPE coated cable)
Power On Function	Power key on key frame will power on
Hinge Angle	0~135 +/- 3 Degrees
Hinge Life	5000 cycles on opening and closing
Hinge Torque	N/A
Opening Force (Free Stop)	N/A
Closed Mode	Magnet assist closure and retention
Book Mode	Magnet assist retention

Product Dimensions				
Product component	Width (No Fabric)	Depth (No Fabric)	Height (Tablet Dependent)	Weight
Keyboard			Variable As Needed	XXX grams

ZAGG®



DRAFT

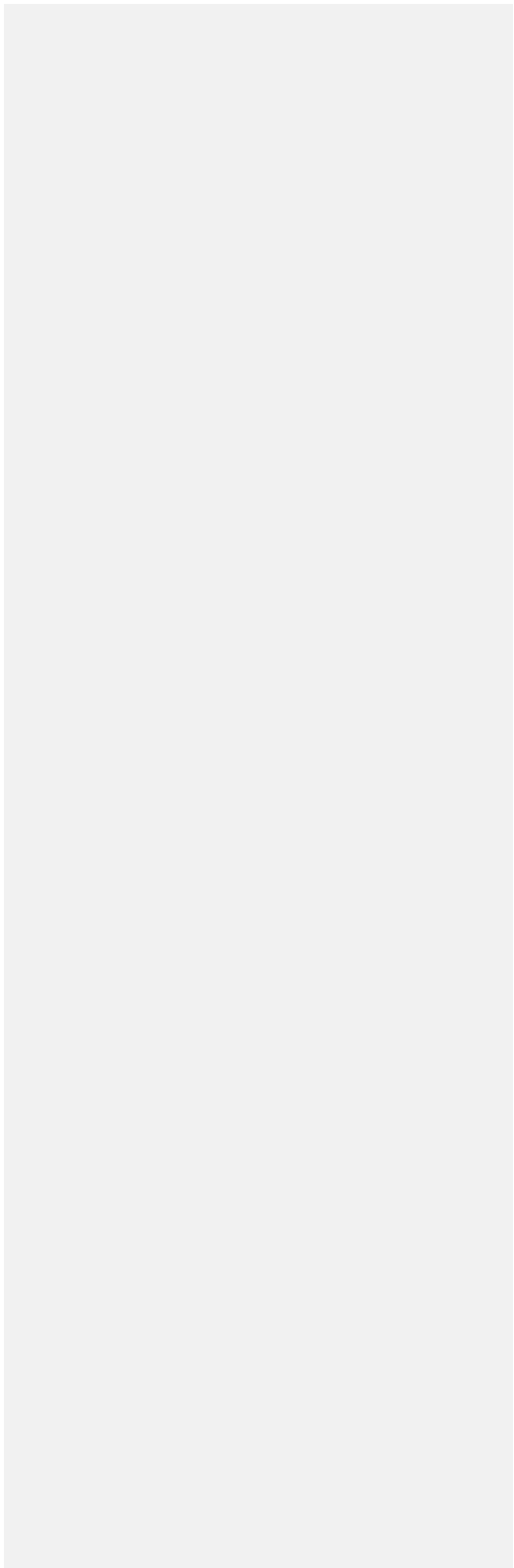



2. Mechanical Specification

2.1. Characteristics of Material

Parts	Material	Color	Texture
Bezel, Key Surround	PC/ABS (70/30)	White/Black/Purple and as needed	MT11010
Keys, HF-3201GS	ABS	White/Black	Texture MT 11005 Semi-Gloss Paint
Fabric Cover, Interior	Synthetic Suede	Black	TBD
Fabric Cover, Exterior	Weave/ Knit	Black/ Purple/ Red	TBD
Side Hooks	PC	White/Black/Purple etc	TBD
Cradle	PC	White/Black/Purple etc	TBD
Base	PC	White/Black/Purple etc	TBD
Top Hooks	PC	White/Black/Purple etc	TBD
V type hook	PC	Black	TBD
Cradle Slim	PC	Black	TBD
Bottom Board	PC	Black	TBD
Cradle Slim Cover	PC	Black	TBD

2.2. Packed – Including Packaging

Product Dimensions		Tolerance: +/- 3 mm			
Package Spec.	Qty	Width	Length	Height	Weight
Gift box with handle	1	TBD	TBD	TBD	TBD
Carton (Inner)	5	TBD	TBD	TBD	TBD
Carton (Outer)	10	TBD	TBD	TBD	TBD



2.3. Detachability of Cable Pull Out

The cable entrance for corded devices can meet product specification. Function test will be performed before and after this test. Refer to the definition of related standard.

USB Implementers Forum. 2007-01-04. Micro USB connector mating force is less than 30N, un-mating force is 8+/-1N. Life test is 5000 cycles in this device.

2.4. Key module configuration

This specification is applied to the 7" key module.

General Product Information	
Product Type	Key module
Output Pin	26 Pin
Travel	1.5 mm
Total Height	3.9 mm
Weight	N/A
Size	198.4 X 96.5 mm (main rectangular foot-print)
Click Ratio	35 ~ 55
Indicator Lights (LED)	RGB
Key life	Standard key and long key: 3 M, Small key: 5 M
Color	Define by Customer
Key layout	Define by Customer

Name	Material	Flaming	UL
Key Cap	ABS	94 HB	
Scissor EXT	POM	94 HB	
Scissor INT	POM	94 HB	
Rubber Dome	Rubber	94 HB	
Plate	0.3 SECC	5VA	
Membrane	PET	94 HB	

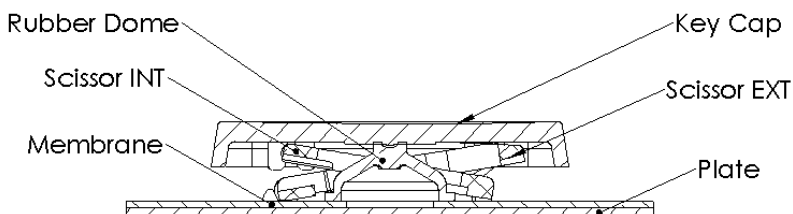



2.5. Key Board Specification

2.6. Life Test

Standard key is 5 million cycles and Function key is 3 million cycles.
 (4 times/second, 100 ± 20 gf).

2.7. Specification of Rubber Switch

Normal And Function Key Rubber Dome Key Characteristic		
Point	Stroke	Force
P1	0.5 ± 0.2 mm	60 ± 15 gf
P2	0.8 ± 0.2 mm	15~48 gf
P3	1.5 ± 0.2 mm	Maximum 120 gf
P4		Maximum 15 gf
Pre-Loading	$0 \sim 0.2$ mm	
Click ratio:	35 – 55 %	

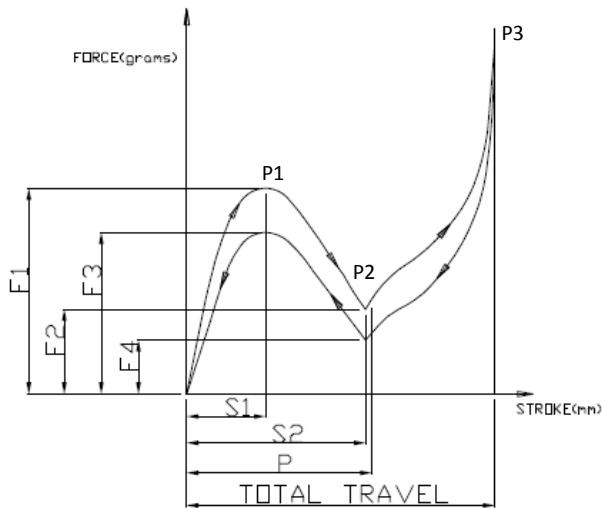

Figure 1 Standard key curve of force response

Travel

Operating Travel: 1.5 ± 0.30 mm

Full Travel: 1.5 ± 0.30 mm (force at 110g)



Keycap Pull Off Force

500gf minimums with equal load applied to all 4 corners of the keycap
150gf minimums at any one corner or side of a given keycap

2.8. Max Keycap Depressing Force

To act on the center of the keycap with stand 5Kgf force for 1 minute.

2.9. Keyboard Height

3.90 ± 0.20mm (normal key)
3.90 ± 0.20mm (space bar)

2.10. Keycap Strength

To act at "X" and "Y" axis with stand 1Kgf force for 5 sec.

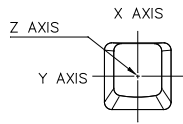

2.11. Keycap Spacing and Alignment

Clearance between keycaps (standard keycaps): $\Delta H (\Delta V) \pm 0.30 \text{ mm}$

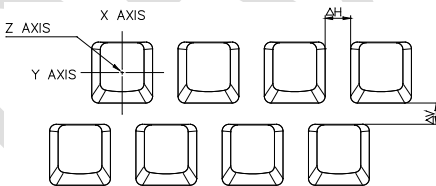

Alignment (keycap to keycap): Neighbor 0.4 mm max, In a row 0.4 mm max
Height alignment (keycap to keycap): Neighbor 0.4 mm max In a row 0.4 mm max
Key slant (keycap to keycap): 0.6 mm max
Key X, Y Movement: Shall be $\leq 0.5\text{mm}$ for full amplitude on both X and y directions.



Key twisting: Normal key $\pm 0.4\text{mm}$

Fn Key $\pm 0.3\text{mm}$

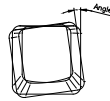

Space key $\pm 0.4\text{mm}$
Long Key $\pm 0.4\text{mm}$

2.12. Key in Test Spec On The 4 Corners Of The Key Cap

Unit: mm (All Types)

A. Standard Key

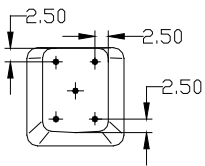

B. Space Bar

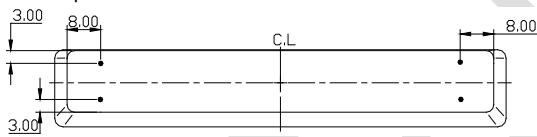

C. Long Types Key

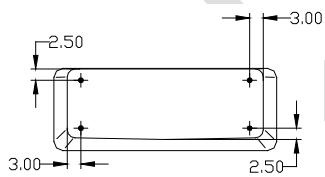

D. Small Key

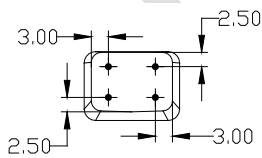

Key in Force (Center) $\geq 80\text{g}$

2.13. Characteristics of Switches

2.14. Slide Switch

No slide switch



2.15. Tact Switch

No tact switch

2.16. Sleep Magnet Function

Act magnet switch in 1.1mm height from top surface of KB cover.

2.17. Snap force and life test

Snap in force between tablet and keyboard cover is (TBD)15N +/- 20% in handle and snap out force is (TBD)25N +/- 20%.

Snap life is (TBD) 5,000 times.

3. Electrical Specification

3.1. Electrical Characteristics

3.2. Feature:

- Bluetooth V 3.0 specification.
- Bluetooth HID profile V 1.1 compliant.
- Frequency Range: 2.400G ~ 2.480GHz
- Peak Power consumption: 0.66 mA Max
- Built-in 3.7V, 450mAh Li-Polymer Battery, can be rechargeable.
- Sleep mode Power consumption: 0.033 mA Max
- Security Encryption: 64 bits
- Support AFH (Adaptive Frequency Hopping).
- Support Language: US, Europe, Asia
- Compatibility with necessary OS
- FCC, CE, BQB, R&TTE, RoHS
- Active Range: around 10 meter
- Build-in Power on/off Switch.
- RGB LED indicators for Battery Low alert , Recharge and Bluetooth Connectivity
- Debounce:
- Wakup Time:
- Auto-pair Requirement:
- BQB Requirement: 10m or 30ft
- Timing of blinking LED:

Commented [OC1]:

	Items	Specifications
1	Operation Voltage:	Voltage supplied to device: 3.0VDC ~ 4.2VDC
2	Active Power consumption	0.65mA Avg
3	Standby Mode current	0.25mA Avg



4	Hibernation mode current	0.033mA Avg
5	Bluetooth disconnect	Bluetooth keyboard will disconnect communication after 20 minutes. The keyboard will always stay paired so when coming out of hibernation it will automatically allow keyboard to work with tablet with limited time delay.

3.3. Power Rating

3.4. LED Indicator behavior

Press Fn + Right Control Key will indicate battery status by LEDs.

- Battery status description:

Battery Voltage	Percentage	Battery Level	LED Colour	Remark
3.71V ~ 4.2V	50% ~ 100%	Full	Green	Flash 3 times. Each time flash 1 sec, stop 1 sec.
3.5V ~ 3.71V	25% ~ 49%	Low	Yellow	Flash 3 times. Each time flash 1 sec, stop 1 sec.
3.4V ~ 3.5V	12% ~ 24%	Charge	Red	Flash 3 times. Each time flash 1 sec, stop 1 sec.
3.0V ~ 3.4V	0% ~ 11%	Critical	Red	Flash 3 times. Each time flash 1 sec, stop 1 sec.

- Power On, Charging, & Pairing:

Function	LED Colour	Remark
Power On	Green LED under power key	The GREEN LED will turn ON instantly when power key is pressed. The LED will turn ON for 2 seconds then turn OFF and the keyboard will



		automatically reconnect with the tablet. If pressed again GREEN LED will turn on 2 seconds then off indicating it is still ON.
Power Off	Red LED under power key	The RED LED will blink twice then turn OFF indicating the keyboard is OFF when the power key is pressed and held down for 3 second. When power is turned OFF the keyboard with disconnect BT.
Charging	Red LED under power key	RED LED stay ON until Battery cell is full Charged.
Low power	Red LED under power key	When battery reaches a Charge level (12%~24%) the back lightning will be disabled and when Critical Level is achieved (0%~11%) a RED LED will flash three times, one flash sequence every 5 minute. (1 Hz Flash 50% Duty)
Bluetooth Pairing	Blue LED under power key	Push and hold Pairing key for 3 seconds for pairing. A BLUE LED under power key will Flash when pairing. Flash will stop flashing when paired. Pairing times out after 60 sec.

- Caps Lock:

Function	LED Colour	Remark
Caps Lock ON	Blue LED under Caps Lock Key	LED Stay on until key is pressed again

- Tablet Bluetooth Display

Function	Name	Remark
Display in Bluetooth settings	ZAGG Basic Folio	Zagg Basic will show in the display of Bluetooth devices the tablet detects

Note: Now the turning ON and OFF of the keyboard through the key frame is really only toggling between Hibernation Mode and Active Mode and disconnecting Bluetooth connection when in Hibernation Mode.

To perform a HARD RESET, a micro USB cable needs to be plugged into a 5V power source and then plugged into the keyboard. A GREEN LED under the power key will come on for 2 seconds then changes to RED indicating the PCBA has been reset.

For all flashing of LED's a flash cycle time 1 Hz Flash 50% Cycle will be used.

3.5. RF Specifications

Simple data transmitter operation at 2.4GHz range



Modulation:	FHSS
Caps Lock ON:	Blue light
Voltage (Supply):	3.0V
Transmitter Output Power:	2.66 dBm
Receiver Sensitivity:	- 86.14 dBm
Range:	>= 10m (in no interference environment)
Auto pairing:	Device starts auto pairing mode after power on, and leaves after 60 seconds.

RF IC Model for keyboard: Broadcom BT3GMD-B47P is a Bluetooth Human Interface Device (HID) module based on the Broadcom BCM20730 Bluetooth 3.0 specification basic rate-compliant stand baseband processor with an integrated 2.4GHz transceiver or equivalent performance chip.

DRAFT

3.6. Bluetooth Module Block Diagram

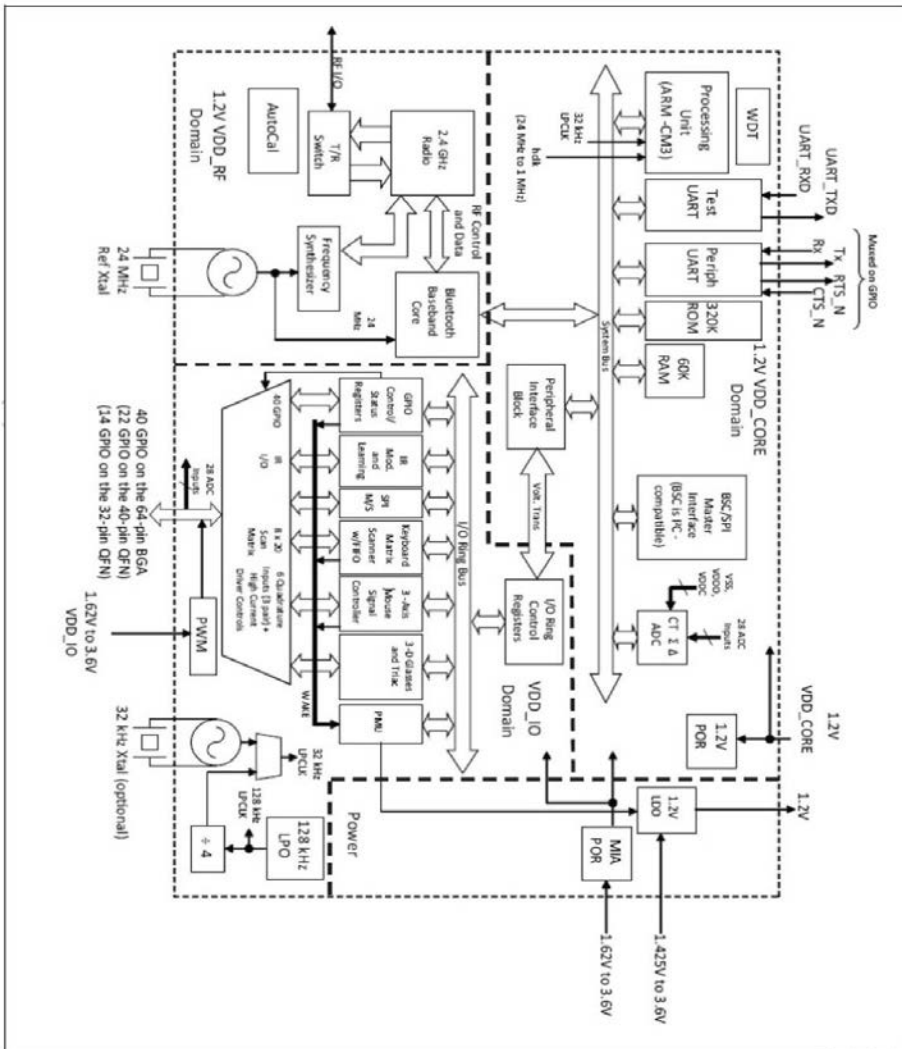

3.7. Sleep mode

Auto sleep if no typing for 20 minutes.



3.8. Keyboard layout

3.9. 7 Inch Key frame

ZAGG ifrogz		The designs represented in this document are protected under U.S. and International trademark and copyright law and are the sole property of ZAGG, Inc. Any reproduction in whole or in part without written permission is prohibited.	
Revision History Table			
Rev	Description	Date	Creator
1	7in Apple Keyboard Layout	10-1-14	Dan Oakeson

Pantone of Function keys --> 284C
Pantone of Key text --> White

US

Product / Code Name: 7in Apple Keyboard Layout	Part (ASM#)	File Name: 7in Apple Keyboard Layout 10-1-14
--	-------------	--

3.10. Fn Combination Key Function Descriptions

3.11. Bluetooth 3.0 9 inch Keyboard Key Matrix for Apple



3.12. Schematic Circuit

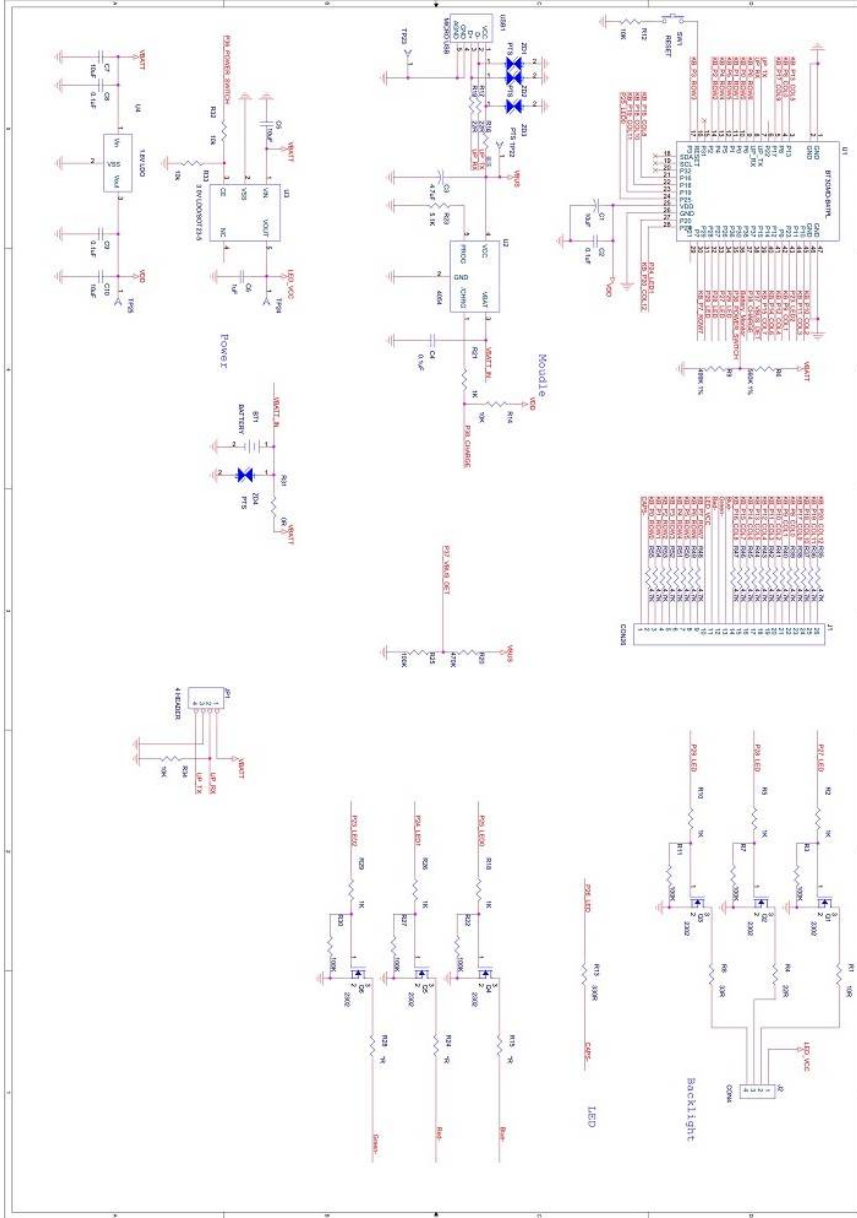



3.13. Pseudo N-Key Rollover Capability

'N' key roller is the numbers of keys that may be held depressed simultaneously and have the keyboard generate the appropriate code for each pressed and released key without keyboard interruption. The keyboard is capable of at least a pseudo 6-key rollover. All combinations of Ctrl, Alt and Shift keys are not ghost keys.

3.14. Free From Illegal Ghost key

Key matrix layout has been properly managed such that no ghost key occurs for any 3-key combination. The ghost key is defined as 3-key combination where a valid third key falls in the '#' pattern in the key matrix, formed by the proceeding valid 2-key combination. Normally in this case, the third key will be masked without sending any code because the third key and fourth key in this '#' pattern are confusing the microprocessor of three keyboard.

3.15. Compatibility

Operation System: Windows OS
Bluetooth 3.0 LE specification compliant.
Bluetooth HID profile V 1.1 compliant
VID/PID in firmware is 0a5c/8502 (Default Broadcom)

3.16. Charging Specification

Charging current: 180mA

3.17. Keyboard Module

Key matrix traces with switch contact fingers are laid out and routed on a 3 layers membrane sheet and scissor keycap as a key module. The contact resistance is less than 1000 ohm.

3.18. Key Functional Test

Refer to Key Layout and to use Bluetooth test program & fixture.

3.19. Bluetooth RF Power & Frequency Test

RF Power Range: -35dBm ~ -5 dBm
Frequency tolerance: +/- 75 KHz
Low Frequency: 2402 MHz
Middle Frequency: 2441 MHz
High Frequency: 2448 MHz

3.20. EMI Test

- European Standard EN 55022: 2006 Class B.
- FCC/CFR 47 : Part 15 Class B
- Frequency Range of Test: from 30MHz to 1000 MHz



3.21. ESD TEST

- Basic standard: IEC 61000-4-2
- Generic standard: EN 55024:1998 + A1:2001 + A2:2003
- Performance Criteria: B
- Level: 2 for Contact discharge
- Tested Voltage: $\pm 8V$ for Air discharge, $\pm 4KV$ for Contact discharge
- Temperature: 15-23 °C
- Relative Humidity: 30-60 % RH
- Test Condition : Air $\pm 8Kv$, $\pm 15Kv$ ESD
- Judgment Standard:
 - $\pm 8Kv$ No malfunction
 - $\pm 15Kv$ No deviation or destruction of component

3.22. EFT Test

- Basic standard: IEC 61000-4-4
- Generic standard: EN 50 082-1
- Performance Criteria: B
- Level: on Power Supply 3
- Test Voltage: on Power Supply $\pm 1KV$
- Temperature: 15-35°C
- Relative Humidity: 30-60 % RH

4. Environmental and Reliability Specifications

4.1. Acoustic Noise

Test Item	Specification	Test Equipment
Acoustic noise	Keyboard : Normal key Max: 50dBA, Space bar: Max:55dBA Mouse: Max:55dBA	

- A = 38 +/- 13mm
- B = 750 +/-13mm
- C = 260 +/-13mm
- D = 330 +/-13mm

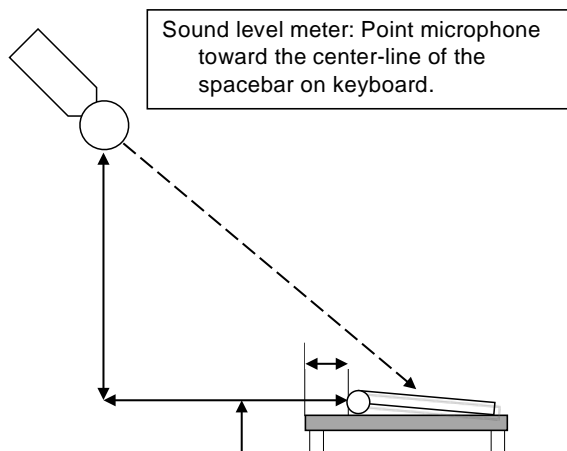

4.2. Temperature and Humidity Test

Test Item	Specification	Test Equipment
High Temp High Humidity Test	<ol style="list-style-type: none"> 1. Sample size: 5 pieces 2. Test Condition: 50°C /95%, 120 hours 3. Judgment Standard: <ul style="list-style-type: none"> • No malfunction • No decay inside of the product 	Chamber
Storing in Low Temperature	<ol style="list-style-type: none"> 1. Sample size: 5 pieces 2. Test Condition: -20°C, 96 hours 3. Judgment Standard: <ul style="list-style-type: none"> - No malfunction 	Chamber

4.3. Heat Treatment Impact Test

Test Item	Specification	Test Equipment
-----------	---------------	----------------



Heat Treatment Impact Test	<ol style="list-style-type: none">1. Sample size: 5 pieces2. Test Condition: -40°C ~ 85°C, 2 hours /cycle, 30cycle3. Judgment Standard:<ul style="list-style-type: none">• No malfunction• No decay or color change of PBA Soldering & component• No crack, dent, or change	Chamber
-------------------------------	---	---------

4.4. Vibration Test

Test Item	Specification	Test Equipment
Vibration	<ol style="list-style-type: none">1. Sample size: 5 pieces2. Condition: Sine sweep: 10HZ~ 500HZ~ 10HZ;3. Sweep speed: 0.5 Octave/minute4. Acceleration: 2G5. Duration: 30 minutes per face.6. Judgment Standard:<ol style="list-style-type: none">i) The mechanical appearance and inner structure should not be damaged after test.ii) No functional failure should be found during and after the test.	Vibration machine



4.5. Bare Unit Drop Test

Test Item	Specification	Test Equipment
Bare unit drop test	<ol style="list-style-type: none">1. Sample size: 2 pieces2. Test Condition : Drop at 91.44 cm (36in) on wood surface, 5 times on each face and 5 times on the top and bottom (Total 30 times without device) NAC and Mahindra Testing3. Judgment Standard<ol style="list-style-type: none">I. No malfunction (button, mechanical or electrical)II. No deviation or destruction of component (No major cracks in plastic housing)	Drop machine

4.6. Packaged Box Drop Test

Test Item	Specification	Test Equipment
Master Carton packaged box drop test	10 drops (One corner, Three edges, Six surfaces) from 36 inches (91.44cm) to concrete surface, No damage product, Product function OK	Drop test machine



4.7. Life Test

Test Item	Specification	Test Equipment
Keycap	Spec: Keyboard normal keys: 5 M cycles Function key: 3 M cycles	Life tester machine
On/Off Button	N/A On Key Frame	
Pairing Button	N/A On Key Frame	
Snap Life Test	Magnetic force between tablet and keyboard is snap in force 6N +/- 20% and snap out force is 6.5N +/- 20%. Snap life is 5,000 times 1. Judgment Standard <ul style="list-style-type: none">No CracksStill connects and hold tablet and	Test by Hand or Machine
Hinge Cycle Test	5000 cycles of hinge with tablet installed. No wear to tablet and torque of hinge cannot change.	

4.8. UV Test

Test Item	Specification	Test Equipment
UV Test	1. Test Standard: ISO4892-3:2006; Method B, 72 Hrs; 0.76 Watts per square meter at 340 nm wavelength, Ambient temperature of 50°C 3°C, Lamp type 1B (UVA-340), Humidity is not controlled. 2. Judgment Standard <ul style="list-style-type: none">No crack / dent / color change and ETC.	



4.9. Spillage Test

Test Item	Specification	Test Equipment
-----------	---------------	----------------

DRAFT

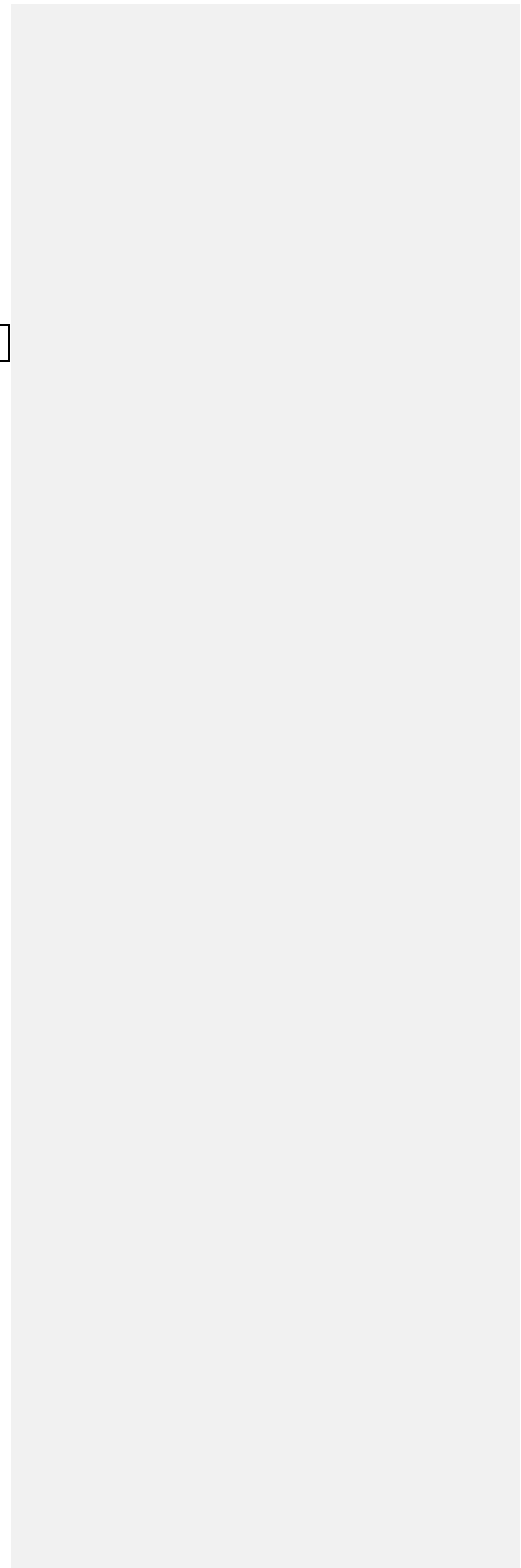



Spillage test	<p>Unit shall be ON.</p> <p>The keyboard shall be functional after performing the liquid spill tests:</p> <p>Pour the liquid from a funneled system from a height of 3.0" above the keyboard over between the G, B, and H keys. The funnel should accurately dispense all the liquid at a rate of approximately 4 Oz (116 cc) per minute of elapsed time. The Keyboard shall remain idle for 60 seconds and then the keyboard shall be tilted to drain the liquid. Liquid for test:</p> <ol style="list-style-type: none"> (1) 8.0 fluid oz. of hot coffee mixture (65C±5C) (Coffee mixture shall be prepared by adding 4.0 gm. of sugar and 2.0 gm. of non-dairy creamer to an 8.0 oz. cup of hot coffee.) (2) 1.0 fluid oz. of cold sugared Cola (15C ±5C) (3) 350cc of water (24±2°C):Don't shake keyboard after complete spilling water, Pour out water. <p>Pass Criteria</p> <ul style="list-style-type: none"> • All keys on the keyboard are functional • Liquid effectively drains from the specific keyboard liquid drain hole(s) Fail Criteria • Liquid does not pass through keyboard and into the drain hole(s) and out the bottom of the keyboard • Spontaneous characters appearing on the screen. • Repeating keys (a repeating key is a key cap that is depressed and release once but continues to scroll the character more than once) <p>Non-Functioning keys</p>	
---------------	---	--

4.10. Endurance Test

Test Item	Specification	Test Equipment
-----------	---------------	----------------



Endurance test	<ul style="list-style-type: none">• Hinge endurance: There shall be no damage, when a load of 25N is applied in pressure direction for 15 seconds.• Rubber pad endurance: Rubber pad does not peel off when a load of 10N is applied on its surface.• Breakage test (25N force applied to top of case.)	Pull gauge.
----------------	---	-------------

4.11. [Physical / Software compatibility check](#)

Test Item	Specification	Test Equipment
Physical / Software compatibility check	Physical / Software Compatibility Test	Window Surface Tablet

4.12. [PLP – Product Liability Program](#)

Test Item	Specification	Test Equipment
PLP	Electronic, Physical PL review, Manual/Package safe clause review	

4.13. [Abrasion Test – Legend \(1X key silk-screen printing\)](#)

Test Item	Specification	Test Equipment
-----------	---------------	----------------



Abrasion test-legend	1,250 cycles, 450g , CS-10F eraser, 50% legend line width missing or damaged	Fixture
----------------------	--	---------

4.14. Abrasion Test - Logo/ Icon

Test Item	Specification	Test Equipment
Abrasion test-Logo/Icon	200 cycles, 450g, CS-10F , 50% legend line width missing or damaged	Fixture

4.15. Abrasion Test – Painting (Outlook parts printing)

Test Item	Specification	Test Equipment
Abrasion test-painting	500 cycles, 1 kg, CS-10 abrasive wheel, substrate is first visible through the painted surface.	Abrasion machine

4.16. Chemical Resistance Test

Test Item	Specification	Test Equipment
Chemical resistance test	Supplier product spec. 12 chemicals per unit, room temperature exposure followed by 60°C/65% RH, 12 chemicals are Oil of Olay; Vaseline with 6.5% Alpha hydroxyl ; Jergen’s Lotion; Eternity Body Lotion; Perfume; 99% Isopropyl Alcohol; 409 Spray Cleaner; Ammonia (Windex); Vegetable Oil, Artificial sweat; Coffee and Coke.	

4.17. Adhesion Test

Test Item	Specification	Test Equipment
Adhesion test	Per ASTM D-3359. must not exhibit paint flaking, peeling, or degradation	



4.18. Keycap Texture Endurance Test

Test Item	Specification	Test Equipment
Keycap texture endurance test	250,000 cycles, 200gm, CS-5 wear eraser, no visual change to surface finish	Abrasion test machine

4.19. Compression Test-Type 1A

Test Item	Specification	Test Equipment
Compression Test-Type 1A	Test 1Min load $L = M \times J \times (H-h) / h \times F$	Compression test machine

4.20. Corrugated Box (Carton) Compression Test

Test Item	Specification	Test Equipment
Corrugated box (Carton) compression test	Minimum compression strength = $((BW \times N) + EPW) \times SF$ BW = Individual Box Weight N = number of boxes in a column above the bottom box EPW = Empty Pallet Weight SF = Safety Factor = 5	Compression test machine

4.21. Compliance

	Items	Specifications
1	USB	Compliance of USB compliance program



4.22. Safety Standard

	Items	Specifications		
1	Regulation (Safety/EMC)	Safety / EMC	Country	Standard
		CE	U.S.A	EN301489, EN300328, IEC 60950-1
		FCC	U.S.A	FCC Part15 Subpart B / C, Class B
		RoHS	U.S.A	Folio
		UL	U.S.A	On Battery
		UN38.3	U.S.A	On Battery
		CEC	California	CEC-400 Battery
		WERC	U.S.A	Battery
		Bluetooth SIG	U.S.A	Bluetooth Module
		Bluetooth Qualification Body	U.S.A	PCBA
		MSDS	U.S.A	Battery
		WEEE	U.S.A	ALL Electrical (Mainly Euro)
		NAC or Mahindra	U.S.A	Complete Folio (ZAGG Performs)

4.23. Environment Specification Items

	Items	Specifications			
1	Compliance to law regulation/ public standards	To be reflected in Product safety (environment) evaluation list To clarify the regulations to correspond to "Law/regulation control standard (product)" appendix "Regulation compliance list" and attach to product planning document or/and product specification document.			
2	Environmental label	To be reflected in environmental label check sheet			
		Destination	If compliance is required or not	Subject	Name
		WW	<input type="checkbox"/>	Main unit <Place to show logo>	International Energy Star program
	Europe	<input checked="" type="checkbox"/>	Main unit	RoHS	
3	Compliance to customer's internal regulation etc. other than above	<input type="checkbox"/> Required <input checked="" type="checkbox"/> Not required			



4.24. Appearance Specification

- Appearance specification: Refer to SIP standard.
- Corrosively: It is not seen the rust part to the appearance part. (Edge of sheet metal is included.)

5. Patent

	Items	Requirement
1	General	There is no infringing of other company patent in worldwide.

6. View Angle

Angle is 133 ± 3 from the table

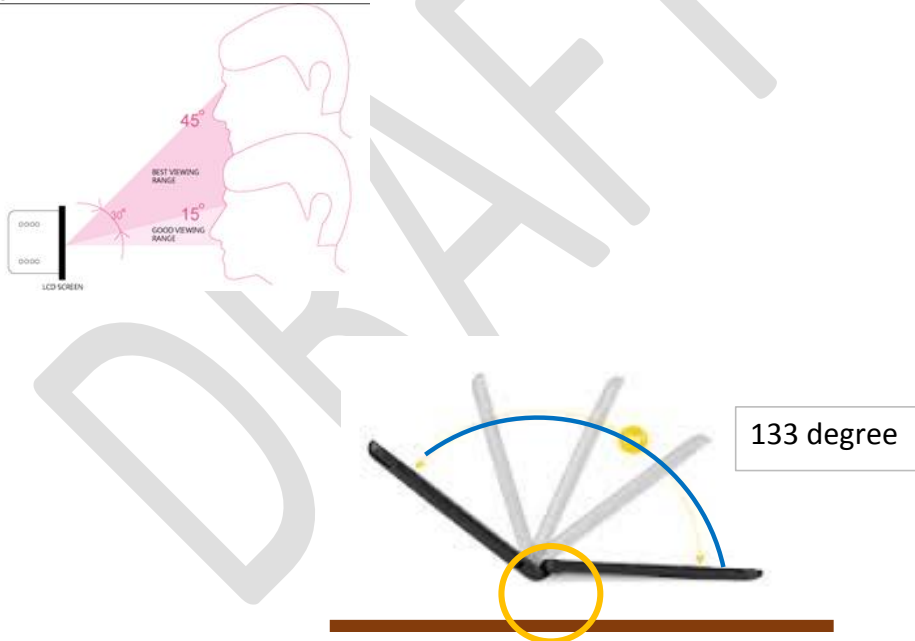

6.1. Angle Specifications

Opening angle of folio	Viewing angle is infinitely variable but must be balanced at 133 degrees from flat surface.
------------------------	---



7. Keyboard Layout for different Languages

8. Cable

8.1. Micro USB Charge Cable

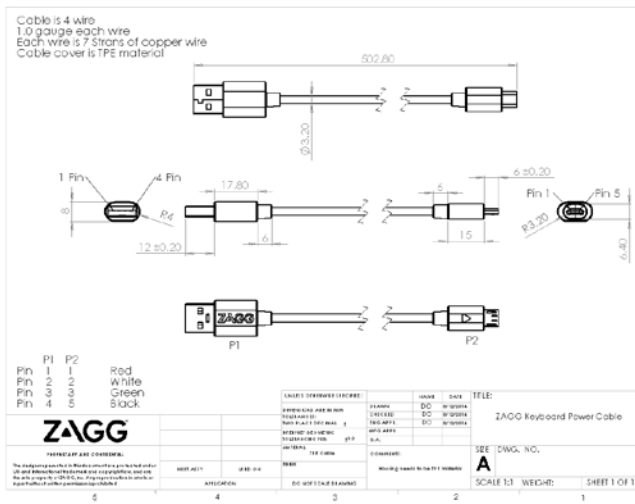

FCC WARNING

This device complies with Part 15 of the FCC Rules. Operation is subject to the following two conditions:

- (1) This device may not cause harmful interference, and
- (2) this device must accept any interference received, including interference that may cause undesired operation.

NOTE 1: Any changes or modifications to this unit not expressly approved by the party responsible for compliance could void the user's authority to operate the equipment.